

# ***SECTION 1-1***

---

## **OPERATION OF INSTRUMENTS AND CONTROLS**

### **Overview of instruments and controls**

Instrument panel overview .....	2
Instrument cluster overview .....	4
Indicator symbols on the instrument panel .....	5

## 2001MY ECHO (U) L/O0008

### Instrument panel overview

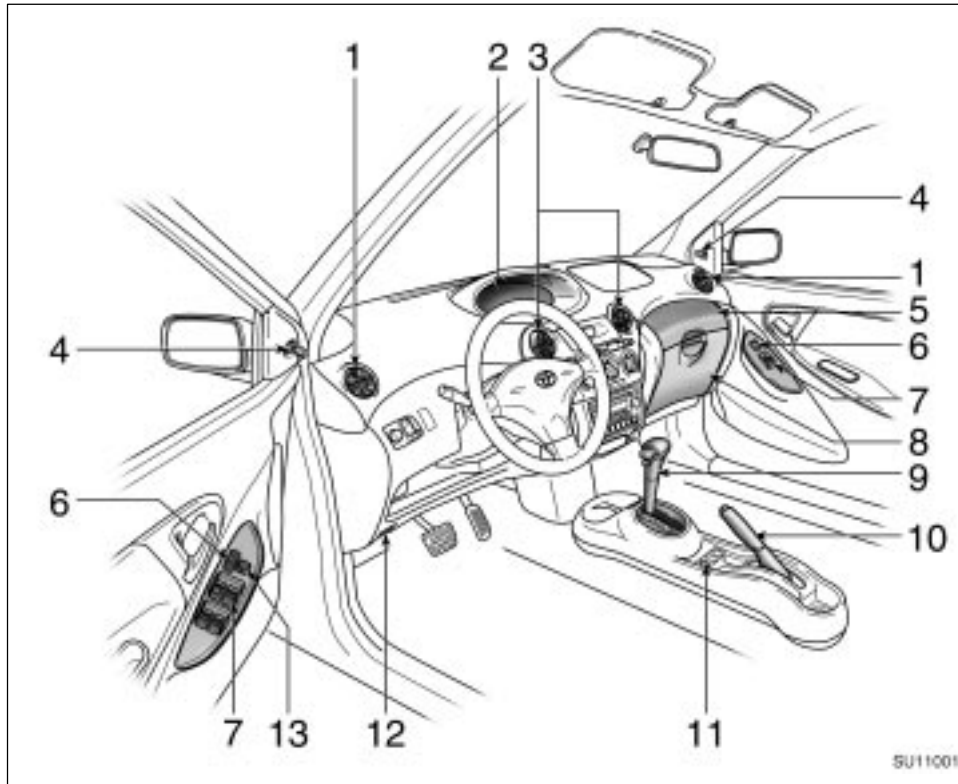

1. Side vents
2. Instrument cluster
3. Center vents
4. Rear view mirror remote control levers
5. Auxiliary box
6. Power door lock switches  
(with power windows)
7. Power window switches
8. Glove box
9. Automatic transmission selector lever or  
manual transmission gear shift lever
10. Parking brake lever
11. Power door lock switch  
(without power windows)
12. Hood lock release lever
13. Window lock switch

## 2001MY ECHO (U) L/O0008

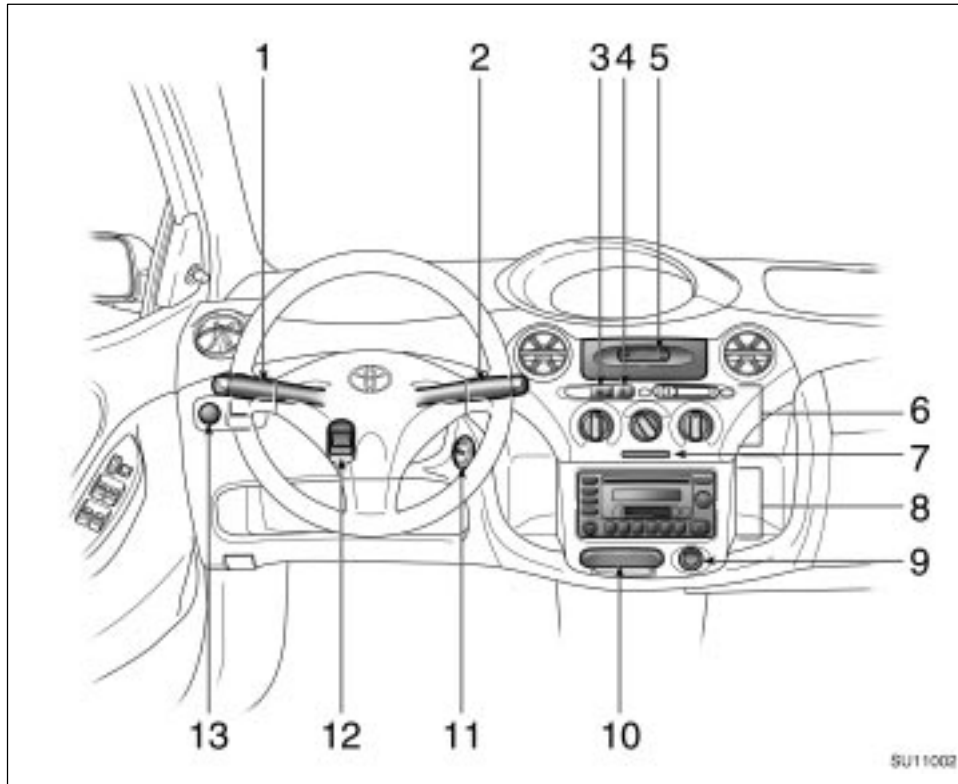

1. Headlight and turn signal switch
2. Wiper and washer switches
3. Rear window defogger switch
4. Emergency flasher switch
5. Clock
6. Air conditioning controls
7. Security indicator light/Front passenger's seat belt reminder light
8. Car audio
9. Cigarette lighter/Power outlet
10. Ashtray/Coin box
11. Ignition switch
12. Tilt steering lock release lever
13. Instrument panel light control knob

**Instrument cluster overview**

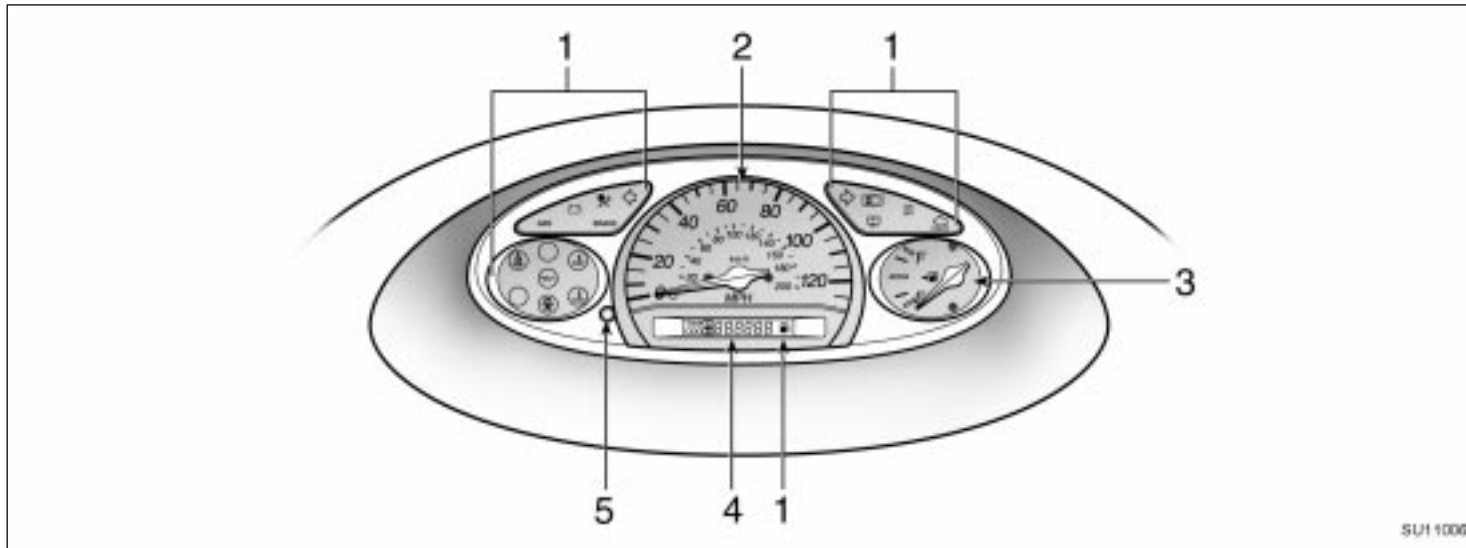















- 1. Service reminder indicators and indicator lights
- 2. Speedometer

- 3. Fuel gauge
- 4. Odometer and two trip meters

- 5. Trip meter reset knob

2001MY ECHO (U) L/O0008

Indicator symbols on the instrument panel

<b>BRAKE</b> or 	Brake system warning light*		SRS warning light*
	Driver's seat belt reminder light*		Low fuel level warning light*
<b>PASSENGER</b> 	Front passenger's seat belt reminder light*		Low windshield washer fluid level warning light*
	Discharge warning light*		Turn signal indicator lights
 CHECK	Malfunction indicator lamp*		Headlight high beam indicator light
	Low oil pressure warning light*	<b>O/D</b> <b>OFF</b>	Overdrive-off indicator light
<b>ABS</b> or 	Anti-lock brake system warning light*		Low engine coolant temperature indicator light (in blue)* High engine coolant temperature warning light (in red)*
	Open door warning light*		

\*: For details, see "Service reminder indicators and warning buzzers" in Section 1-5.

**2001MY ECHO (U) L/O0008**