

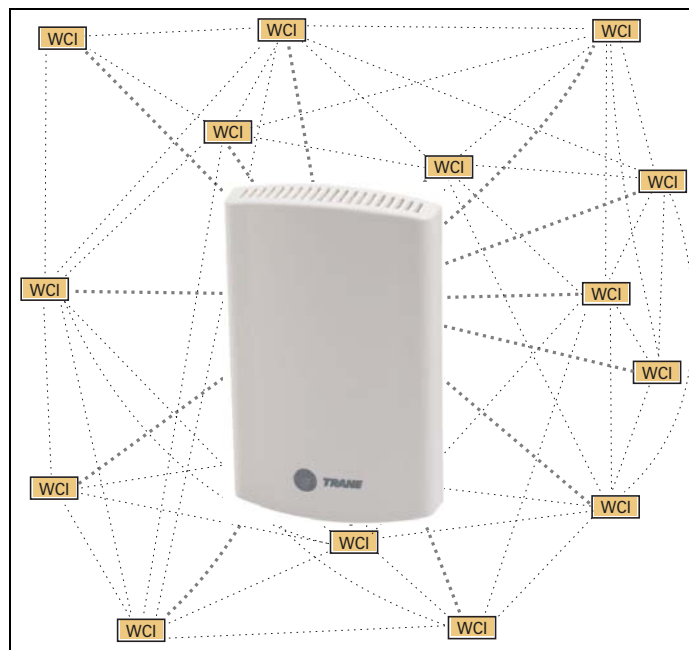

# Installation, Operation, and Maintenance

## Wireless Comm



### **⚠ SAFETY WARNING**

Only qualified personnel should install and service the equipment. The installation, starting up, and servicing of heating, ventilating, and air-conditioning equipment can be hazardous and requires specific knowledge and training. Improperly installed, adjusted or altered equipment by an unqualified person could result in death or serious injury. When working on the equipment, observe all precautions in the literature and on the tags, stickers, and labels that are attached to the equipment.

# Introduction

Read this manual thoroughly before operating or servicing this unit.

## Warnings, Cautions, and Notices

Safety advisories appear throughout this manual as required. Your personal safety and the proper operation of this machine depend upon the strict observance of these precautions.

The three types of advisories are defined as follows:

**⚠ WARNING** Indicates a potentially hazardous situation which, if not avoided, could result in death or serious injury.

**⚠ CAUTION** Indicates a potentially hazardous situation which, if not avoided, could result in minor or moderate injury. It could also be used to alert against unsafe practices.

**NOTICE:** Indicates a situation that could result in equipment or property-damage only.

## Important Environmental Concerns

Scientific research has shown that certain man-made chemicals can affect the earth's naturally occurring stratospheric ozone layer when released to the atmosphere. In particular, several of the identified chemicals that may affect the ozone layer are refrigerants that contain Chlorine, Fluorine and Carbon (CFCs) and those containing Hydrogen, Chlorine, Fluorine and Carbon (HCFCs). Not all refrigerants containing these compounds have the same potential impact to the environment. Trane advocates the responsible handling of all refrigerants-including industry replacements for CFCs such as HCFCs and HFCs.

## Important Responsible Refrigerant Practices

Trane believes that responsible refrigerant practices are important to the environment, our customers, and the air conditioning industry. All technicians who handle refrigerants must be certified. The Federal Clean Air Act (Section 608) sets forth the requirements for handling, reclaiming, recovering and recycling of certain refrigerants and the equipment that is used in these service procedures. In addition, some states or municipalities may have additional requirements that must also be adhered to for responsible management of refrigerants. Know the applicable laws and follow them.

### ⚠ WARNING

#### Proper Field Wiring and Grounding Required!

Failure to follow code could result in death or serious injury. All field wiring **MUST** be performed by qualified personnel. Improperly installed and grounded field wiring poses **FIRE** and **ELECTROCUTION** hazards. To avoid these hazards, you **MUST** follow requirements for field wiring installation and grounding as described in NEC and your local/state electrical codes.

### ⚠ WARNING

#### Personal Protective Equipment (PPE) Required!

Failure to wear proper PPE for the job being undertaken could result in death or serious injury. Technicians, in order to protect themselves from potential electrical, mechanical, and chemical hazards, **MUST** follow precautions in this manual and on the tags, stickers, and labels, as well as the instructions below:

- Before installing/servicing this unit, technicians **MUST** put on all PPE recommended for the work being undertaken. **ALWAYS** refer to appropriate MSDS sheets and OSHA guidelines for proper PPE.
- When working with or around hazardous chemicals, **ALWAYS** refer to the appropriate MSDS sheets and OSHA guidelines for information on allowable personal exposure levels, proper respiratory protection, and handling recommendations.
- If there is a risk of arc or flash, technicians **MUST** put on all PPE in accordance with NFPA 70E or other country-specific requirements for arc flash protection, **PRIOR** to servicing the unit.

## Copyright

This document and the information in it are the property of Trane and may not be used or reproduced in whole or in part, without the written permission of Trane. Trane reserves the right to revise this publication at any time and to make changes to its content without obligation to notify any person of such revision or change.

## Trademarks

All trademarks referenced in this document are the trademarks of their respective owners.

# Table of Contents

Introduction .....	2
Warnings, Cautions, and Notices .....	2
Important Environmental Concerns .....	2
Important Responsible Refrigerant Practices .....	2
General Information .....	5
Product Description .....	5
Dimensions .....	6
Specifications and Agency Compliance .....	7
Location Considerations .....	9
Maximum Wire Length .....	9
Installation Locations .....	9
Coordinator Location .....	9
WCI Addressing .....	10
Setting Network Communication Addressing .....	10
Setting Wireless Zone Sensor Receiver Addressing .....	11
Mounting and Wiring the WCI .....	12
Controller Applications .....	12
Repeater Applications .....	16
Establishing the Network .....	17
WCI LEDs and Buttons .....	17
Three Ways to Establish a Wireless Network .....	19
Establishing the Network After Tracer SC Installation .....	19
Establishing the Network Prior to Tracer SC Installation or Without Tracer SC Installation .....	19
WCIs as Zone Sensor Receivers .....	20
Modifying the Network .....	22
Adding Additional WCIs to an Existing Network .....	22
Adding Additional Coordinators to a Tracer SC .....	22
Removing a WCI from a Network .....	23
Replacing a WCI on a Network .....	23
Closing the Network .....	23
Disbanding a Network .....	23
Troubleshooting .....	24
WCI does not join network .....	24
Tracer SC does not communicate with WCI .....	24
Sensor does not communicate with WCI .....	24
No communication .....	25

---

Slow communication .....	25
Replacing a Failed WCI .....	25
Appendix: Using the Tracer™ TU Service Tool with Wireless Networks ....	27
Requirements for Joining .....	27
Joining Tracer TU with a Wireless Network .....	27
Managing a Wireless Network and Devices .....	29
Connecting to a Device .....	29
Wireless Menu .....	30
Wireless Zone Sensor Enable/Disable .....	32



# General Information

This section provides general information about the wireless Comm interface (WCI).

## Product Description

The Trane® Wireless Comm Interface (WCI) enables wireless communication between system controls, unit controls, and wireless sensors for the new generation of Trane control products. The WCI replaces the need for communication wire in all system applications.

### Types of Devices Supported by the WCI

- Tracer™ SC system controller
- Tracer™ UC400 programmable controller
- Tracer™ UC600 programmable controller
- BCI-I: BACnet Communications Interface for IntelliPak™ systems
- BCI-R: BACnet Communications Interface for ReliaTel™ systems
- Tracer™ TU
- Wireless zone sensors

### Quantity of WCIs per Network

Each Trane wireless network can have a total of 31 WCIs (30 member WCIs plus 1 coordinator WCI). Each network requires one WCI to function as network coordinator.

### Quantity of Networks per Tracer SC

A Tracer SC can support up to 8 wireless networks.

**Note:** For information about installing a WCI on a Tracer SC, see [“Mounting and Wiring the WCI,” p. 12 and Figure 6, p. 14.](#)

### Automatic Network Formation

When a WCI is connected to a Tracer SC, it is auto-assigned as the coordinator. To enable the coordinator, Tracer SC must be configured for wireless communication. The coordinator WCI opens the network to allow all WCIs having matching addresses to automatically join the network.

If no Tracer SC is present, a centrally located WCI must be designated to act as the coordinator. You can manually set the coordinator WCI so all WCIs having matching addresses automatically join the network.

**Note:** For additional information, see [“Establishing the Network,” p. 17.](#)

### Wireless Zone Sensors

The WCI also communicates with Trane wireless zone sensors, eliminating the need for analog receivers.

### Wired Zone Sensors

Systems using Wireless Comm can also use wired zone sensors.

### Network Security

The WCI uses standard ZigBee™ Building Automation security practices by the use of AES128 encryption, keys, and device authentication.

### Part Numbers

Available models are listed by part number:

Part number	Description
X13790901	Includes wiring harness and screws. For field-mount applications.
X13790902	For flush-mount applications. (Wiring harness not included.)

Part number	Description
X13790903	Bulk version of X13790901, no wiring harness, no installation instructions. For factory ordering in bulk.
X13790904	Bulk version of X13790902, no wiring harness, no installation instructions. For factory ordering in bulk.
X13641194	Outdoor enclosure to protect WCI from harsh environments or wet indoor environments.

## Dimensions

The dimensions of the WCI enclosure are as follows:

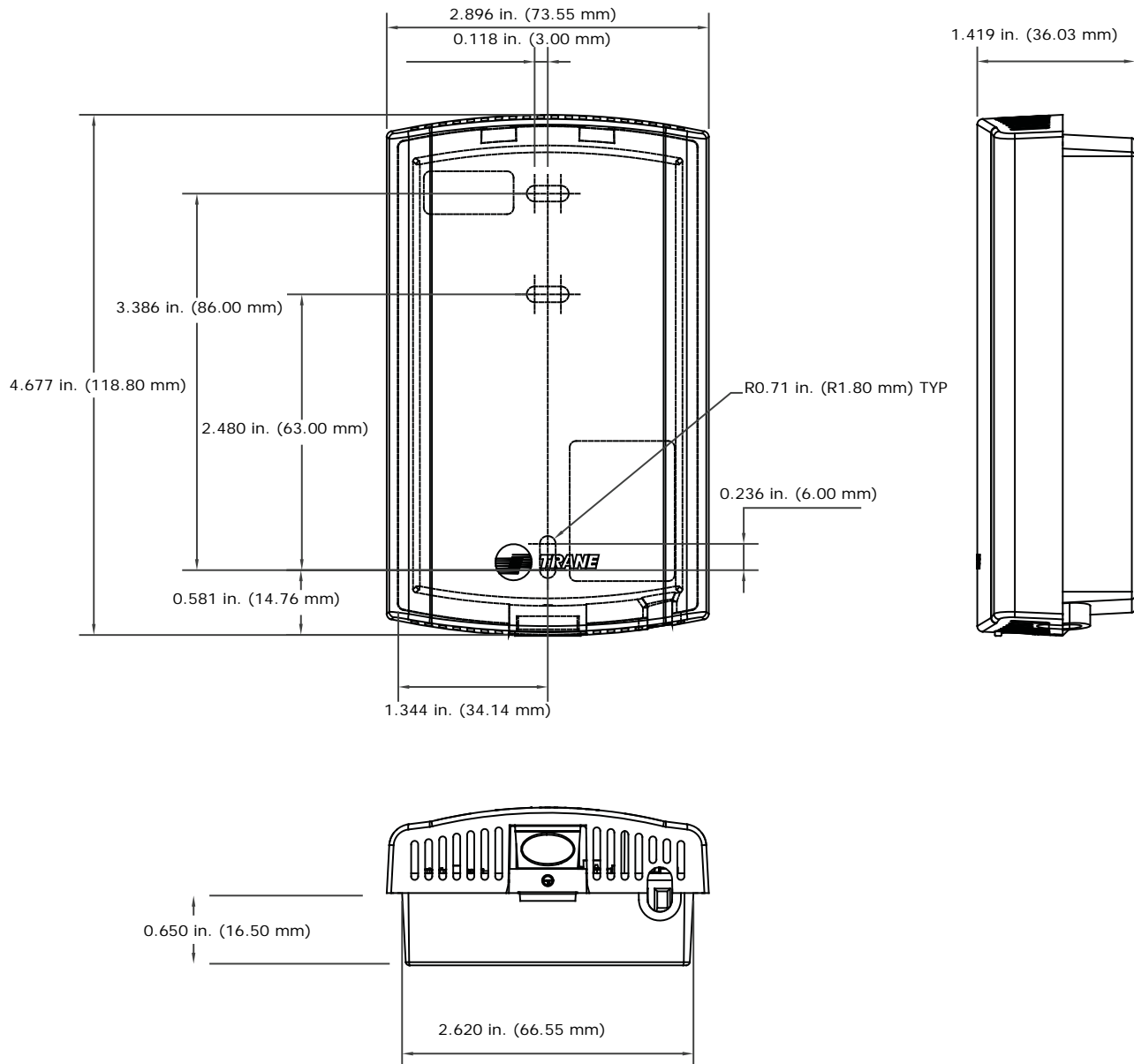

## Specifications and Agency Compliance

Specifications	
Operating temperature	-40 to 158°F (-40 to 70°C)
Storage temperature	-40 to 185°F (-40 to 85°C)
Storage and operating humidity range	5% to 95% relative humidity (RH), non-condensing
Voltage	24 Vac/Vdc nominal ± 10% If using 24 Vac, polarity must be maintained.
Receiver power consumption	<2.5 VA
Housing material	Polycarbonate/ABS (suitable for plenum mounting), UV protected, UL 94: 5 VA flammability rating
Mounting	3.2 in (83 mm) with 2 supplied mounting screws
Range <sup>(a)</sup>	Open range: 2,500 ft (762 m) with packet error rate of 2% Indoor: Typical range is 200 ft (61 m); actual range is dependent on the environment. See BAS-SVX55 for more detail.
Output power	North America: 100 mW
Radio frequency	2.4 GHz (IEEE Std 802.15.4-2003 compliant) (2405–2480 MHz, 5 MHz spacing)
Radio channels	16
Address range	Group 0–8 Network 1–9
Mounting	Fits a standard 2 in. by 4 in. junction box (vertical mount only). Mounting holes are spaced 3.2 in. (83 mm) apart on vertical center line. Includes mounting screws for junction box or wall anchors for sheet-rock walls. Overall dimensions: 2.9 in. (74 mm) by 4.7 in. (119 mm)
Wireless protocol	ZigBee PRO—ZigBee Building Automation Profile, ANSI/ASHRAE Standard 135-2008 Addendum q (BACnet™/ZigBee)
Agency compliance	
United States	<p>UL listed: UL 94, 5 VA flammability rating and UL916.</p> <p>Energy Management Equipment FCC CFR47, Sec. 15.247 &amp; subpart E, Digital Modulation Transmission with no SAR (FCC ID: TPF-251701).</p> <p>This device complies with part 15 of the FCC Rules. Operation is subject to the following two conditions: (1) This device may not cause harmful interference, and (2) this device must accept any interference received, including interference that may cause undesired operation.</p> <p>Changes or modifications not expressly approved by the manufacturer for compliance could void the user's authority to operate the equipment.</p> <p><b>Note:</b> This equipment has been tested and found to comply with the limits for a Class B digital device, pursuant to part 15 of the FCC Rules. These limits are designed to provide reasonable protection against harmful interference in a residential installation. This equipment generates, uses and can radiate radio frequency energy and, if not installed and used in accordance with the instructions, may cause harmful interference to radio communications. However, there is no guarantee that interference will not occur in a particular installation. If this equipment does cause harmful interference to radio or television reception, which can be determined by turning the equipment off and on, the user is encouraged to try to correct the interference by one or more of the following measures:</p> <ul style="list-style-type: none"> <li>• Reorient or relocate the receiving antenna.</li> <li>• Increase the separation between the equipment and receiver.</li> <li>• Connect the equipment into an outlet on a circuit different from that to which the receiver is connected.</li> <li>• Consult the dealer or an experienced radio/TV technician for help.</li> </ul>

Canada	<p>CSA-C22.2 No. 205-M1983 Signal Equipment Industry Canada (IC: 6178A-251701)</p> <p>Cet appareil est conforme à la partie 15 du règlement du FCC. Son fonctionnement fait l'objet des deux conditions suivantes : (1) Cet appareil ne produit pas de brouillages nuisibles, et (2) cet appareil doit pouvoir recevoir n'importe quel type d'interférence, y compris les brouillages pouvant occasionner un fonctionnement non désiré.</p> <p>Les changements et les modifications n'ayant pas été approuvés expressément par le fabricant comme étant conformes, pourraient rendre nulle le droit de l'utilisateur à faire fonctionner cet équipement.</p> <p><b>Remarque:</b> Cet équipement a été testé et reconnu comme étant conforme aux limites des appareils numériques de classe B, tel qu'indiqué dans la partie 15 du règlement du FCC. Ces limites ont été établies afin de fournir un niveau de protection raisonnable contre le brouillage nuisible dans les installations résidentielles. Cet appareil produit, utilise, et peut aussi émettre des fréquences radioélectriques. Si celui-ci n'est pas installé et utilisé conformément aux instructions, il peut provoquer des brouillages nuisibles dans les communications radioélectriques. L'absence d'interférence n'est cependant pas garantie dans toutes les installations. Si cet équipement provoque des brouillages nuisibles dans la réception des communications radioélectriques ou de télévision (ceci pouvant être déterminé en allumant et en éteignant l'équipement), l'utilisateur est encouragé à essayer de corriger l'interférence en utilisant un ou plusieurs des moyens suivants :</p> <ul style="list-style-type: none"> <li>• Réorienter ou changer l'emplacement de l'antenne réceptrice.</li> <li>• Éloigner l'équipement et le récepteur l'un de l'autre.</li> <li>• Brancher l'équipement à une prise de courant se trouvant sur un circuit différent de celui sur lequel le récepteur est branché.</li> <li>• Faire appel aux services du fournisseur ou d'un technicien radio/TV qualifié.</li> </ul>
IEEE/radio frequency range	IEEE 802.15.4-2003, IEEE Standard for Information Technology—Telecommunications and information exchange between systems—Local and metropolitan area networks—Specific requirements, Part 15.4: Wireless Medium Access Control (MAC) and Physical Layer (PHY) Specifications for Low Rate Wireless Personal Area Networks (LR-WPANS)

(a) Range values are estimated transmission distances for satisfactory operation. Actual distance is job specific and must be determined during site evaluation. Placement of the WCI is critical to proper system operation. In most general office space installations, distance is not the limiting factor for proper signal quality. Signal quality is more greatly affected by walls, barriers, and general clutter. Note that sheetrock walls and ceiling tiles offer little restriction to the propagation of the radio signal throughout the building as opposed to concrete or metal barriers. More details information, including wiring schematics, are available at <http://www.trane.com>.



## Location Considerations

To provide the best signal strength between associated wireless devices and to reduce the number of WCIs needed for an application, mount WCIs in direct, unobstructed, line-of-sight paths. Locate WCIs so that the number of metal and concrete barriers between pairs of devices is minimal. In general, sheetrock walls and ceiling tiles are not of concern.

For more detailed information about WCI placement, see the *Wireless Comm Network Design Best Practices Guide* (BAS-SVX55).

### **⚠ CAUTION**

#### **Avoid exposure to electromagnetic energy!**

The WCI produces very low levels of electromagnetic energy. To avoid exposure, keep the WCI a minimum of 8 in. (20 cm) from your body.

#### **Risque d'exposition à l'énergie électromagnétique!**

L'interface de communication (WCI) sans fil produit de l'énergie électromagnétique de très bas niveau. Afin d'empêcher toute exposition, maintenez-la à au moins 20 cm (8 pouces) de votre corps.

The WCI produces very low levels of electromagnetic (RF) energy. To avoid exposure, keep the WCI a minimum of 8 in. (20 cm) from your body.

## Maximum Wire Length

The maximum wire length between the WCI and its power source is 656 ft (200 m).

## Installation Locations

### **Unit controller**

For a unit controller installation, the most typical WCI mounting location is on the sheet metal enclosure of the unit controller or HVAC equipment housing.

### **Rooftop or air-handling unit**

The recommended location is outside of the rooftop or air-handling unit. In outdoor locations, the WCI should be mounted inside of a plastic enclosure suitable for outdoor use. Kele PS 1811-9 and TK 1811 are recommended models.

### **Repeaters overcome out-of-radio-range issues**

A WCI can be installed to function as a repeater to bridge the signal between a WCI that is out of the radio range of the other WCIs (see ["Repeater Applications," p. 16](#)). When choosing a location for a repeater WCI, consider the availability of a 24 Vac/Vdc power source to meet its power requirement.

## Coordinator Location

For optimum network performance and reliability, the coordinator WCI should be centrally located within the network. See the *Wireless Comm Network Design Best Practices Guide* (BAS-SVX55) for more detail.

# WCI Addressing

This section describes the WCI addressing scheme and procedure. WCIs can be ordered either pre-addressed or without addresses. Verify pre-addressed WCI prior to installation.

## Setting Network Communication Addressing

**Important:** Addresses must be set on WCIs before applying power to them.

Follow this procedure to set the WCI address for network communication. Figure 1 illustrates the addressing scheme used for WCIs. The illustration shows four networks and two Tracer SCs, with each Tracer SC communicating on two networks. See Table 1, p. 11 for address settings.

1. Set the left (GRP) rotary address switch for each WCI that is in the same Tracer SC group to an identical number. (A Tracer SC group refers to all of the networks that communicate with the same Tracer SC.)
2. Set the right (NET) rotary address switch for each WCI that is to be on the same network to an identical number. If there are multiple networks in a Tracer SC group, each network in that group must have a unique number.

**Note:** The NET address must match the wireless link on Tracer SC.

Figure 1. WCI addressing example

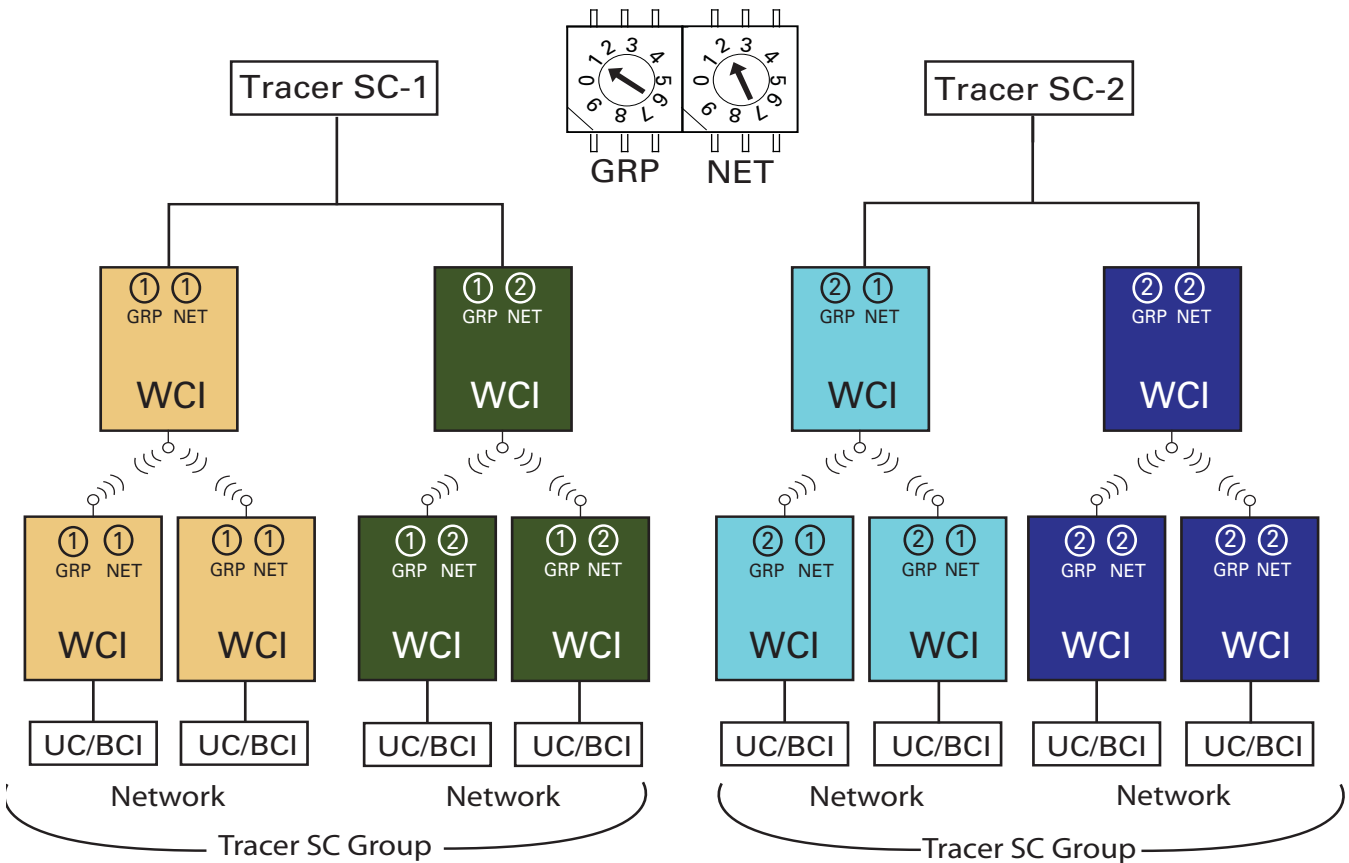

**Note:** The Wireless Comm Network Design Best Practices Guide (BAS-SVX55) provides an example of network addressing from a floor plan perspective.

**Table 1. Address settings**

Function/Purpose	GRP	NET
Trane BACnet communication and receiver for sensor	0–8	1–8
Receiver for sensor only	1–9	0
Return to default configuration	0	0
Future use	9	1–8

## Setting Wireless Zone Sensor Receiver Addressing

A WCI that is installed on a unit controller as a wireless communication interface can also function as a zone sensor receiver. To set up this function, follow this procedure:

### **⚠ WARNING** Hazardous voltage!

**Disconnect all electric power, including remote disconnects before servicing. Follow proper lockout/tagout procedures to ensure that power cannot be inadvertently energized. Failure to disconnect power before servicing could result in death or serious injury.**

1. Make sure that AC power is disconnected from the unit controller that the WCI is installed on.
2. Choose unit controller and wireless zone sensor addresses so that no two wireless zone sensors sharing the same address are within radio range of each other. (Addresses above 127 may be used for Wireless Comm systems; see *Wireless Comm Network Design Best Practices Guide* (BAS-SVX55) for more information.)
3. Set the address on the wireless zone sensor to match the rotary address setting on the unit controller (see [Figure 2](#)).

**Note:** *The numbers on the WCI rotary address switches are oriented differently from those on the unit controllers, as the illustration indicates.*

**Figure 2. Wireless zone sensor addressing**

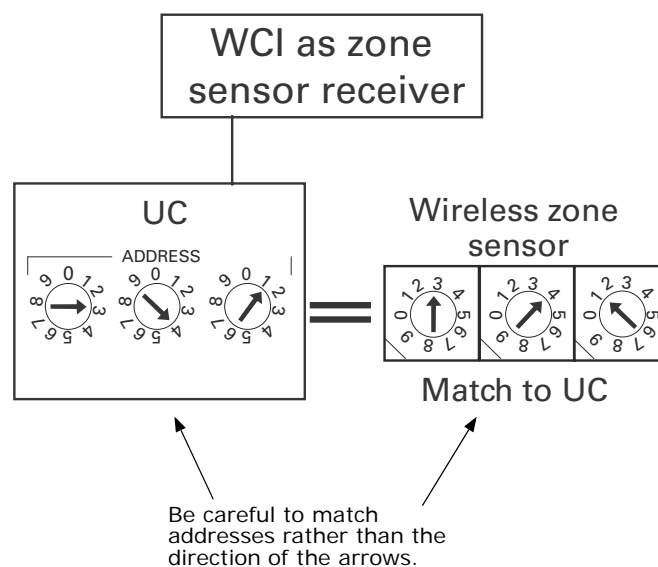

# Mounting and Wiring the WCI

Follow these instructions:

**⚠ WARNING**

**Hazardous Service Procedures!**

Disconnect all electric power, including remote disconnects before servicing. Follow proper lockout/tagout procedures to ensure the power can not be inadvertently energized. Failure to disconnect power before servicing could result in death or serious injury.

## Controller Applications

1. Remove power from the controller that is to have the WCI wired to it.
2. Remove the WCI cover by firmly pressing the thumb tab at the bottom of the cover and pulling the cover away from the back plate (Figure 3).

**Note:** If present, remove the security screw before removing the cover.

**Figure 3. Removing the cover**

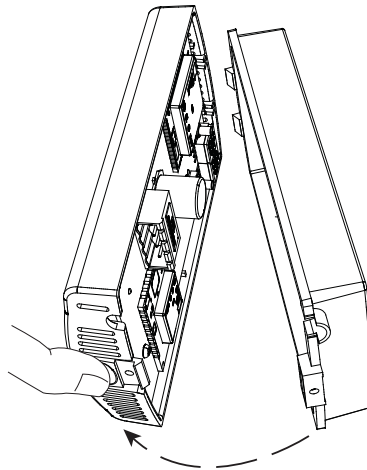

3. Secure the backplate to the mounting surface using appropriate hardware. (M3.5 x 20 mm self-drilling screws are provided.)
4. Attach the 4-conductor screw terminal block on the wiring harness to the receptacle on the WCI (Figure 4).

**Figure 4. Connecting wiring harness**

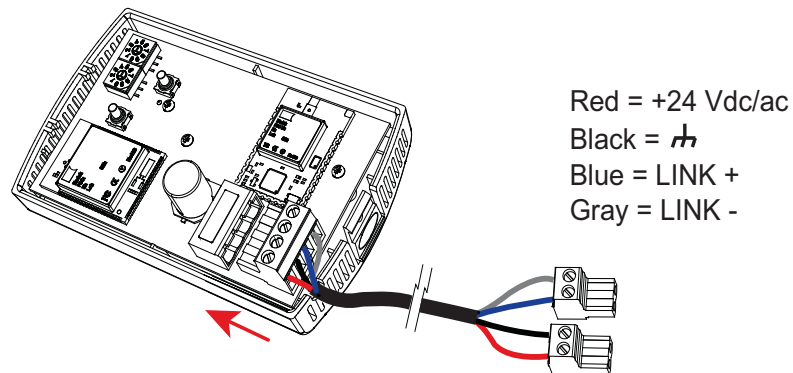

5. Route the wires from the WCI through either:
  - a. The opening in the back plate (Figure 5, a).
  - b. The bottom exit port (Figure 5, b).

**Figure 5. Routing the wires through the WCI backplate (a) or bottom exit port (b)**

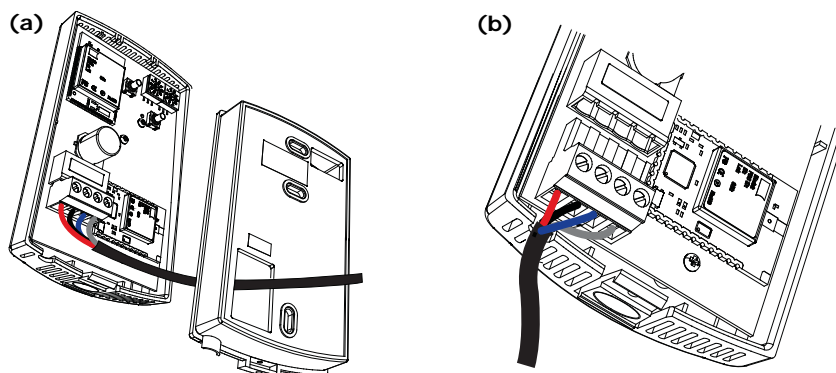

6. Connect the wiring harness according to the illustration that is appropriate for your application:

**Note:** Wiring between a WCI and a controller cannot exceed 656 ft (200 m). If the wiring harness does not provide enough length, use 18 AWG (24 pF/ft max.) communication wire (Trane purple wire).

- To wire the WCI to a Tracer SC, see Figure 6, p. 14.
- To wire the WCI to a UC400 or a UC600, see Figure 7, p. 14.
- To wire the WCI to a BCI-I, see Figure 9, p. 15.
- To wire the WCI to a BCI-R, see Figure 10, p. 15.

7. Restore power to the controller.

**Important:** The WCI must be wired to the controller prior to power up in order to establish network communication.

8. The network is ready to be formed. Refer to “Establishing the Network,” p. 17.

## Mounting and Wiring the WCI

Figure 6. Wiring the WCI to a Tracer SC

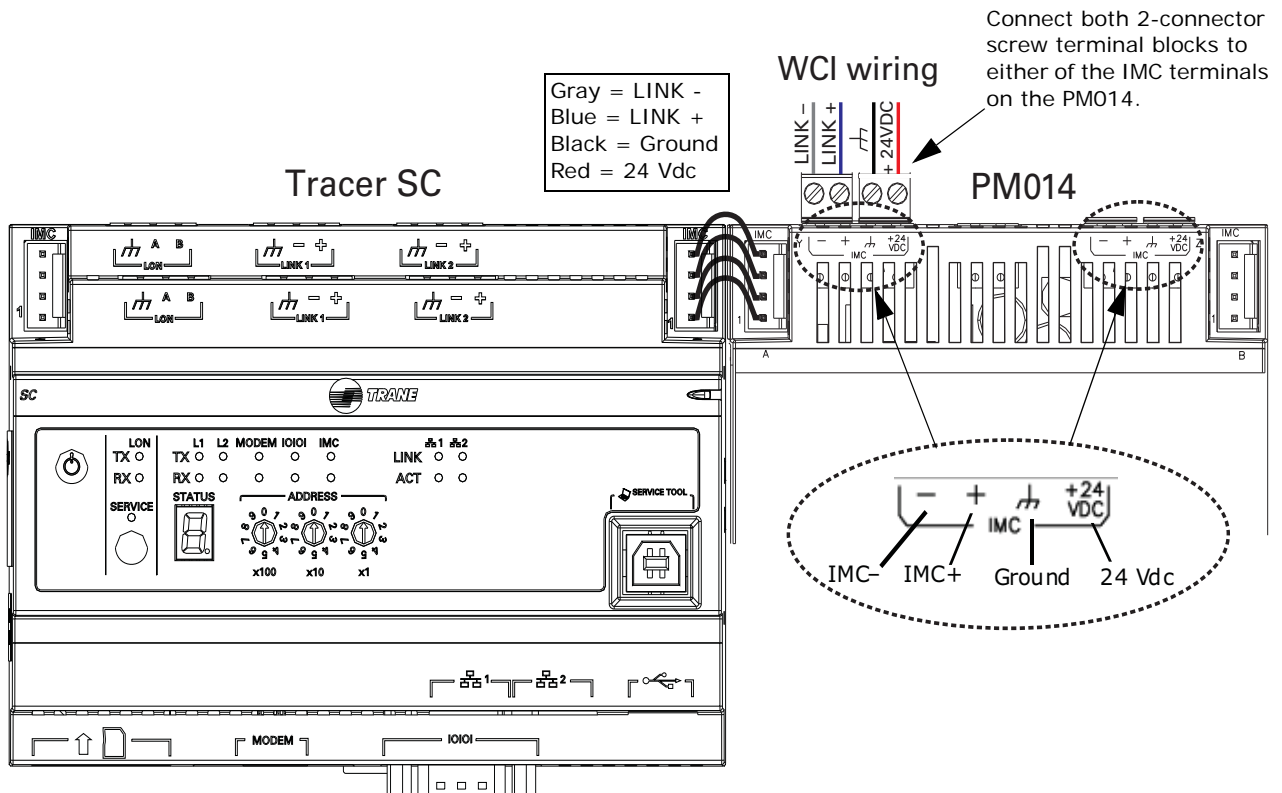
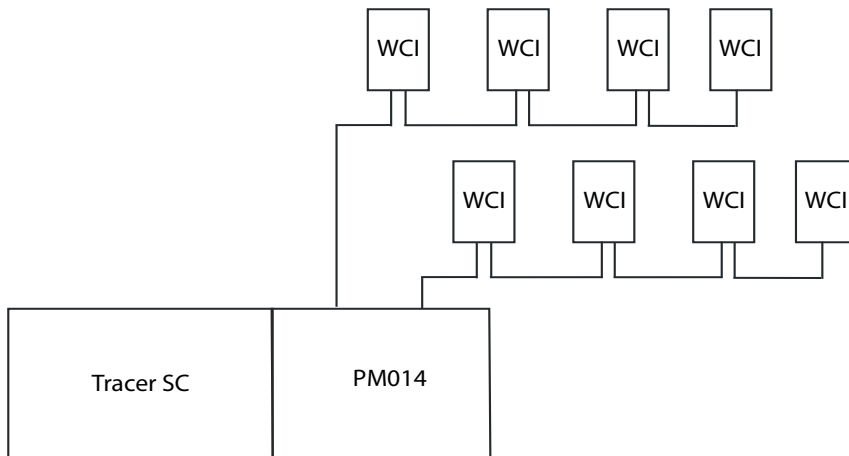

Figure 7. Wiring multiple WCIs to a Tracer SC



**Notes:**

- A maximum of eight WCIs can be daisy-chained to the Tracer SC.
- Use both IMC terminals on the PM014 for wiring multiple WCIs (see the detail in Figure 6).

## Mounting and Wiring the WCI

Figure 8. Wiring the WCI to a UC400 or a UC600

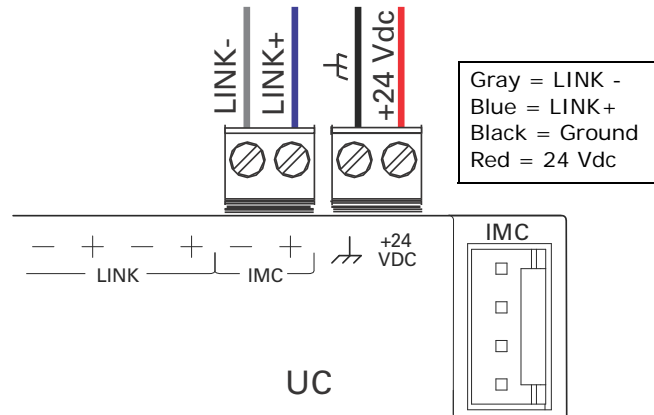

Figure 9. Wiring the WCI to a BCI-I

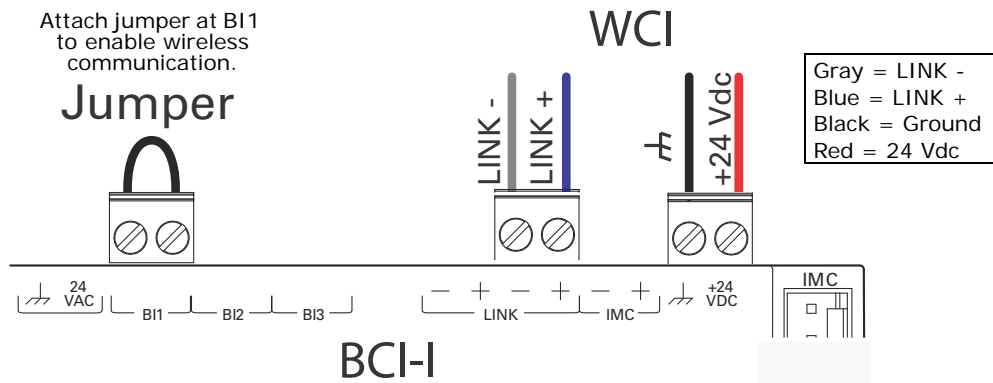
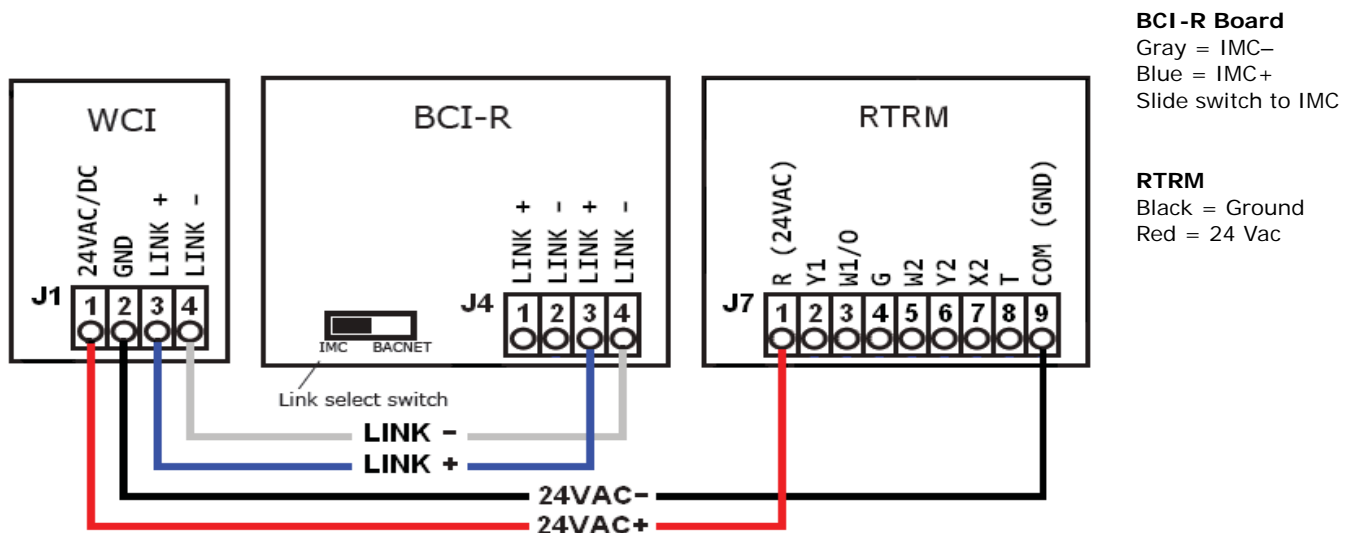

Figure 10. Wiring the WCI to a BCI-R



### Repeater Applications

**Note:** For more information about the use of repeaters with Wireless Comm, see the *Wireless Comm Network Design Best Practices (BAS-SVX55)*.

To install a WCI to function as a repeater:

1. Remove power from the controller that is to have the WCI wired to it.
2. Remove the WCI cover by firmly pressing the thumb tab at the bottom of the cover and pulling the cover away from the back plate (Figure 3, p. 12).

**Note:** If present, remove the security screw before removing the cover.

3. Secure the backplate to the mounting surface using appropriate hardware. (M3.5 x 20 mm self-drilling screws are provided.)
4. Attach the 4-connector screw terminal block on the wiring harness to the receptacle on the WCI (Figure 4).
5. Remove the blue (IMC+) and gray (IMC-) wires from the wiring harness.
6. Connect the red (24 Vdc/Vac) wire and black (ground) wire through the opening in the backplate (Figure 5a) or the bottom exit port (Figure 5b) to a 24 V power source.

**Figure 11. Wiring a WCI as a repeater**

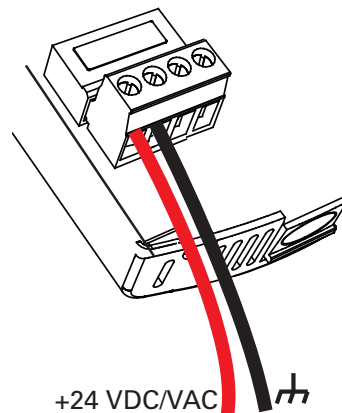

7. Restore power to the controller.
8. If the WCI communication wire was previously connected to a unit controller, return the WCI to its default configuration as follows:
  - a. Set its rotary address switch to 0,0 (the WCI must be powered).
  - b. Observe its LEDs blink On briefly (<1 second).
  - c. Reset its rotary address switches to the correct network address.

You are now ready to add the repeater to an existing network (refer to [“Adding Additional WCIs to an Existing Network,”](#) p. 22) or to proceed with establishing a new network (refer to [“Establishing the Network,”](#) p. 17).



# Establishing the Network

When all aspects of hardware installation are complete, you are ready to power up the system and establish the network. Before you perform these tasks, ensure that all work described in the *“WCI Addressing,”* p. 10 and *“Mounting and Wiring the WCI,”* p. 12 sections are complete.

## WCI LEDs and Buttons

Before establishing a network, you should be familiar with the layout of the WCI board, the behavior of its LEDs, and the function of its buttons. The WCI board contains two buttons and several LEDs. The LEDs relevant to network formation are shown in [Figure 12](#).

**Figure 12. LEDs and buttons related to network formation**

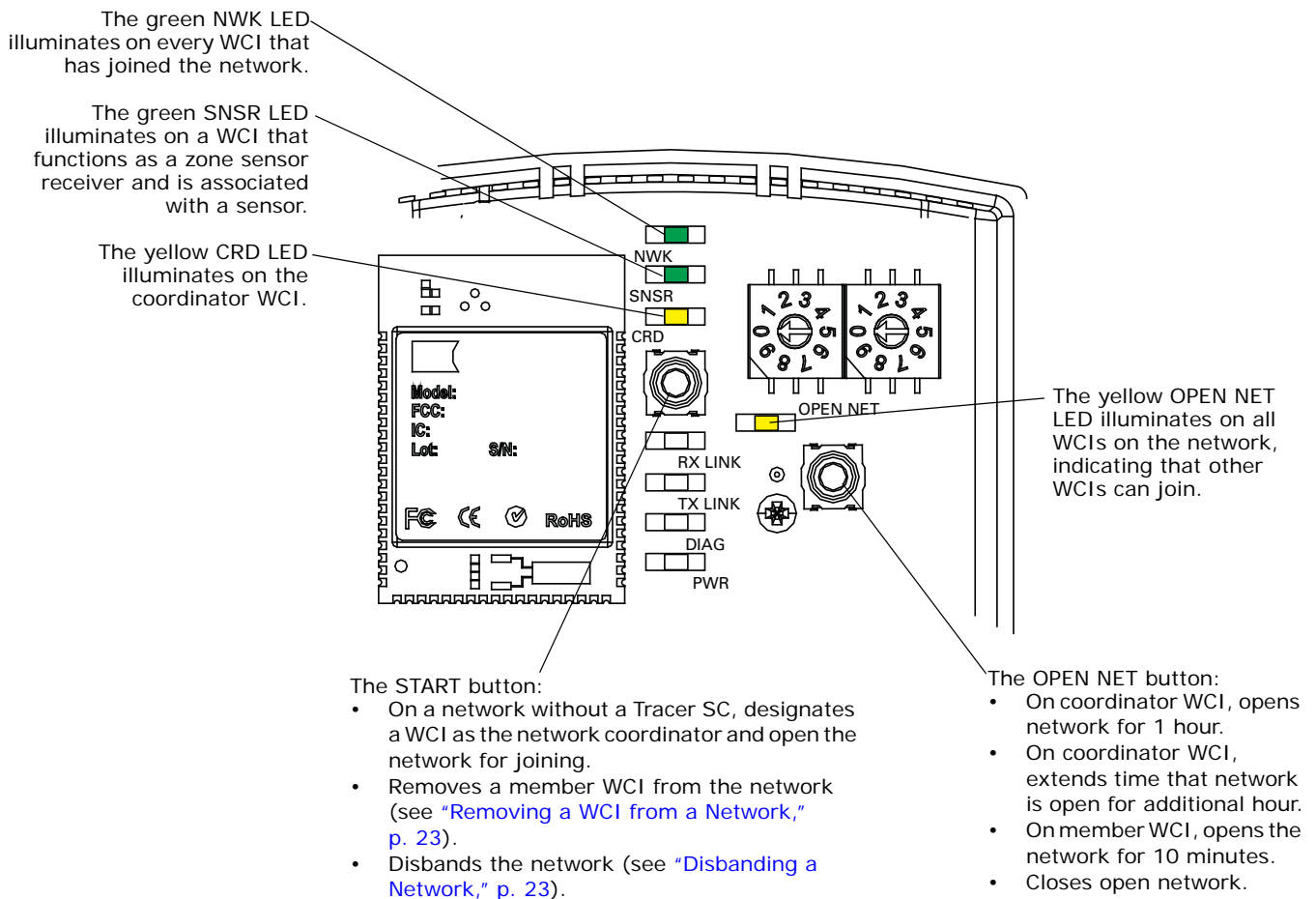

## Establishing the Network

---

On power-up, the WCI goes through a check list and updates LED activity according to the type of device associated with the WCI and the status of the WCI in the network. The LED flash patterns vary depending on current conditions. LED behavior is described in [Table 2](#).

**Table 2. LED identification and interpretation**

LED	LED activity	Indicates...
Network LED (green) <b>NWK</b>	On solid	WCI is a network member.
Sensor LED (green) <b>SNSR</b>	Flashes	Sensor has lost its association with the WCI.
	On solid	A sensor is associated with the WCI.
Coordinator LED (yellow) <b>CRD</b>	On solid	WCI is network coordinator.
Open Net LED (yellow) <b>OPEN NET</b>	On solid	Network is open for joining.
	Off	Network is closed.
Reception LED (yellow) <b>RX LINK</b>	Flickers	Data is being received.
Transmission LED (green) <b>TX LINK</b>	Flickers	Data is being transmitted.
Diagnostic LED (red) <b>DIAG</b>	Flashes 50% on/off	Hardware failure or failed re-flash of a radio.
	Triple flash pattern. Occurs for 30 seconds after failing to join a network.	WCI is not configured correctly by the unit controller or IMC communication is down.
	Double flash pattern	WCI lost MAC address on radios or WCI lost ability to communicate with radio.
	If more than one condition is present, the priority is in the order listed.	
Power LED (green) <b>PWR</b>	On solid	WCI has power.

## Three Ways to Establish a Wireless Network

A wireless network can be established:

- After a Tracer SC has been installed.
- Prior to Tracer SC installation.
- On a network that will not have a Tracer SC installed on it.

### Establishing the Network After Tracer SC Installation

If a Tracer SC is installed prior to establishing the wireless network, the WCI that is installed on a Tracer SC automatically becomes the network coordinator after power is applied to the Tracer SC. If multiple WCIs are installed on a Tracer SC, each WCI forms an independent network for which it is the coordinator.

Follow this procedure:

1. Observe the yellow CRD LED on the WCI illuminate to identify the WCI wired to the Tracer SC as the network coordinator (see [Figure 12, p. 17](#)).
2. Observe the yellow OPEN\_NET LED illuminate on the coordinator WCI. This LED remains lit for 1 hour, indicating that the network is open to allow WCIs with matching addresses to join the network for that duration. After each WCI joins, the 1 hour timer starts over.

**Note:** *If the network closes because the timer has expired, you can open the network for an additional hour by pressing the OPEN\_NET button. To extend time on a network that has not yet closed, press the OPEN\_NET button to close the network, then press it again to open the network for an additional hour. As an alternative, you can use Tracer TU to open the network.*

3. Observe the green NWK LED illuminate:
  - On the coordinator WCI, indicating that it has joined its own network.
  - On each additional WCI as it joins the network.

**Note:** *Typically, it takes about 10 minutes for a WCI to join the network. However, the time is dependent on the distance between the WCIs in network as well as the size and type of structures that may exist between them.*

4. After the network is formed, press the OPEN\_NET button on the coordinator to close the network if it is still open (indicated by an illuminated OPEN\_NET LED).
5. To enable and configure Tracer SC for the new wireless network, see Tracer SC Online Help and the current edition of the *Tracer SC System Controller Installation and Setup* guide (BAS-SVX31).

### Establishing the Network Prior to Tracer SC Installation or Without Tracer SC Installation

If a Tracer SC has not been installed at the time that you are ready to establish the network or will never be installed on the network, follow this procedure to establish the network.

#### Task 1: Activate Communication Among Existing WCIs

1. Choose a centrally located WCI that has been wired to a unit controller to become the network coordinator.

**Note:** *This WCI will be network coordinator temporarily, if the network is to have a Tracer SC installed on it at a later time. At that time, the WCI that is installed on the Tracer SC will become the network coordinator.*

2. Press the START button for 5 seconds to establish the WCI as the coordinator and to open the network for joining. The yellow CRD LED on the WCI illuminates to identify the WCI as the network coordinator (see [Figure 12, p. 17](#)).

## Establishing the Network

---

3. Observe the yellow OPEN\_NET LED illuminate on the coordinator WCI. This LED remains lit for 1 hour, indicating that the network is open to allow WCIs with matching addresses to join the network for that duration. After each WCI joins, the 1 hour timer starts over.

**Notes:** *If the network closes because the timer has expired, you can open the network for an additional hour by pressing the OPEN\_NET button. To extend time on a network that has not yet closed, press the OPEN\_NET button to close the network, then press it again to open the network for an additional hour.*

4. Observe the green NWK LED illuminate:
  - On the coordinator WCI, indicating that it has joined its own network.
  - On each additional WCI as it joins the network.

**Notes:** *Typically, it takes about 10 minutes for a WCI to join the network. However, the time is dependent on the distance between the WCIs in network as well as the size and type of structures that may exist between them.*

5. After the network is formed, press the OPEN\_NET button on the coordinator to close the network if it is still open (indicated by an illuminated OPEN\_NET LED).

### Task 2: Installing a Tracer SC After Network Formation

After a Tracer SC is installed on a previously established network, the network must be disbanded and then re-established. Follow this procedure:

1. On the WCI that is currently the network coordinator, press the START button for 10 seconds. The network will disband.
2. Install an addressed WCI on the Tracer SC following addressing and wiring instructions (see [“WCI Addressing,”](#) p. 10 and [“Mounting and Wiring the WCI,”](#) p. 12).

After power is restored to the Tracer SC, the WCI that is installed on the Tracer SC automatically becomes the network coordinator and a new network is established.

3. Observe the yellow OPEN\_NET LED illuminate on the coordinator WCI. This LED remains lit for 1 hour, indicating that the network is open to allow WCIs with matching addresses to join the network for that duration. After each WCI joins, the 1 hour timer starts over.

**Note:** *If the network closes because the timer has expired, you can open the network for an additional hour by pressing the OPEN\_NET button. To extend time on a network that has not yet closed, press the OPEN\_NET button to close the network, then press it again to open the network for an additional hour.*

4. Observe the green NWK LED illuminate:
  - On the coordinator WCI, indicating that it has joined its own network.
  - On each additional WCI as it joins the network.

**Note:** *Typically, it takes about 10 minutes for a WCI to join the network. However, the time is dependent on the distance between the WCIs in network as well as the size and type of structures that may exist between them.*

5. After the network is formed, press the OPEN\_NET button on the coordinator to close the network if it is still open (indicated by an illuminated OPEN\_NET LED).
6. To enable and configure Tracer SC for the new wireless network, see Tracer SC Online Help and the current edition of the *Tracer SC System Controller Installation and Setup* guide (BAS-SVX31).

## WCIs as Zone Sensor Receivers

On a WCI that functions as a zone sensor receiver, observe the green SNSR LED illuminate to confirm association with the wireless zone sensor (see [Figure 13](#)).

**Note:** To set up the addressing for this function, see [“Setting Wireless Zone Sensor Receiver Addressing,” p. 11.](#)

**Figure 13. Wireless zone sensor/receiver association**

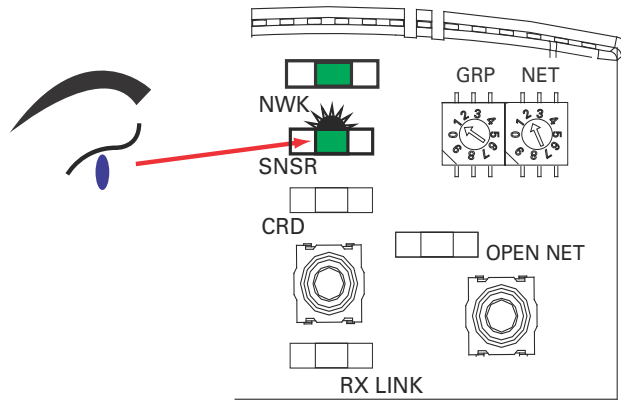

**Notes:** To observe the radio signal strength between the sensor and receiver, press the Test button on the sensor. For more information about the wireless zone sensor, see the current edition of *Wireless Sensors: Installation, Operation, and Maintenance* (BAS-SVX04).



## Modifying the Network

This section describes how to modify an established wireless network. Most modifications can be made by using either the Tracer TU service tool or the WCI.

To use Tracer TU, you must establish communication with a wireless network and attach to a wireless device. For instructions, see [“Appendix: Using the Tracer™ TU Service Tool with Wireless Networks,” p. 27.](#)

## Adding Additional WCIs to an Existing Network

### Using Tracer TU

1. After attaching TU to a wireless device, select **Open Network** from the **Wireless** menu.  
Any WCI with a correct rotary address setting that is located within radio range of a network member, will join the network.
2. Observe the green NWK LED illuminate on a WCI that joins the network.

### Using a WCI

1. Press the OPEN\_NET button on any WCI on the network to open the network for joining.  
Any WCI with a correct rotary address setting that is located within radio range of a network member, will join the network.
2. Observe the green NWK LED illuminate on a WCI that joins the network.

## Adding Additional Coordinators to a Tracer SC

A Tracer SC can have a total of eight WCIs installed on it. Each WCI installed on a Tracer SC becomes the coordinator of a separate network. If additional coordinator WCIs/networks are needed on a Tracer SC after the network has been formed, follow these steps.

1. Remove power from the Tracer SC. (This will not affect the existing networks.)
2. Address the new WCI(s) according to the scheme explained in [“WCI Addressing,” p. 10,](#) making sure the addresses do not conflict with existing WCIs.
3. Install the WCI(s) on the Tracer SC as described in [“Mounting and Wiring the WCI,” p. 12,](#) [Figure 6, p. 14,](#) and [Figure 7, p. 14.](#) Use a daisy-chain configuration to install multiple WCIs.
4. A new network will be created for each newly installed WCI, with each WCI as coordinator of the newly created network. Allow sufficient time for all member WCIs to join the new network.
5. Start Tracer SC Device discovery. (Refer to Tracer SC online help for the discovery procedure.) Devices that previously existed on the wireless network do not need to be rediscovered.

## Removing a WCI from a Network

If a coordinator WCI fails, the network ceases to exist. If the other WCIs that were members of the disbanded network find an open network within radio range, they will try to join that network. To prevent that from occurring, you can remove WCIs from the network until the coordinator WCI is replaced.

### Using Tracer TU

After attaching Tracer TU to a wireless device:

1. Select **Remove from Network** from the **Wireless** menu.
2. Change the rotary address setting on the WCI to prevent the WCI from re-joining the network.

### Using the WCI

To remove a member (non-coordinator) WCI, press its START button (10–15 seconds) until the green NWK LED turns Off.

**Note:** *The same action performed on the coordinator WCI will disband the network.*

After the WCI is dropped from the network, the equipment managed by the associated unit controller is under the direct, local control of the unit controller.

To remove a coordinator WCI, change its rotary address setting.

## Replacing a WCI on a Network

See [“Replacing a Failed WCI,” p. 25.](#)

## Closing the Network

To prevent WCIs from joining an open network (indicated by an illuminated OPEN\_NET LED), you can close the network by using Tracer TU or a member WCI.

### Using Tracer TU

After attaching Tracer TU to a wireless device, select **Close Network** from the **Wireless** menu.

### Using a WCI

To close an open network (indicated by an illuminated OPEN NET LED) so that other WCIs cannot join, push the OPEN NET button on any WCI on the network.

## Disbanding a Network

Some rare circumstances may require disbanding the network.

### Using Tracer TU

After attaching Tracer TU to the network coordinator, select **Disband Network** from the **Wireless** menu. As the network disbands, the NWK LEDs on all WCIs on the network respond by turning Off.

### Using a WCI

Press the START button (for approximately 10-15 seconds) on the coordinator WCI until the yellow CRD LED and the green NWK LED turn Off. As the network disbands, the NWK LEDs on all WCIs on the network respond by turning Off.

# Troubleshooting

## WCI does not join network

Possible cause	Explanation/Resolution
Not enough time allowed for joining.	Give the WCI more time to join. If the network closes before the WCI has joined, re-open if necessary by pressing the OPEN NET button.
Wrong address	For factory addressed WCIs, verify addresses with equipment report. Verify each WCI address after installation. If sensor is installed, check for error code at sensor. Initiate network formation and resolve by exception.
No power	Ensure that: <ul style="list-style-type: none"> <li>The WCI is wired correctly.</li> <li>The corresponding controller is wired to equipment correctly and is powered On.</li> </ul>
Too much traffic	Try a different channel. A better channel may be found by trial and error or by using a tool such as WiSpy.
Outside of radio range or too many obstacles	Relocate WCI
Defective WCI	Replace

## Tracer SC does not communicate with WCI

Possible cause	Explanation/Resolution
No power to the WCI	Ensure that the WCI is wired properly to the Tracer SC
Wireless link on the Tracer SC	Ensure that the wireless link on the Tracer SC is enabled and configured to match WCI address, and is unique within the building.
One of the devices is outside of radio range	Move network components to within radio range or break up networks to make smaller so that all components are within radio range.

## Sensor does not communicate with WCI

**Note:** Error code E7 appears on sensor.

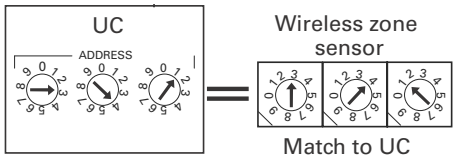
Possible cause	Explanation/Resolution
Sensor/unit controller address mismatch	<p>Ensure that the sensor address matches the unit controller address. <b>Note:</b> Be sure to match addresses rather than the direction of the arrows.</p> 
No power	See "Maintenance and Troubleshooting" in the current version BAS-SVX04, <i>Wireless Sensors: Installation, Operation, and Maintenance</i> .
Defective sensor or receiver	Replace defective device



### No communication

Possible cause	Explanation/Resolution
Power loss	If power loss causes communication to be lost, the coordinator WCI will re-initiate the network as soon as power is returned.
Signal obstruction	If an obstruction causes communication to be lost, the coordinator WCI will re-initiate the network as soon as communication is regained.
One of the devices is outside of radio range	Move network components to within radio range or break up networks to make smaller so that all components are within radio range.

### Slow communication

Possible cause	Explanation/Resolution
Duplicate unit controller BACnet Device IDs.	Make sure that every device on the network has a unique BACnet Device ID. Refer to the current version of BAS-SVX51, <i>BACnet MS/TP Wiring and Link Performance Best Practices and Troubleshooting Guide</i> .

### Replacing a Failed WCI

#### Task 1: Remove the failed WCI

#### **⚠ WARNING**

#### **Hazardous Voltage!**

**Disconnect all electric power, including remote disconnects before servicing. Follow proper lockout/tagout procedures to ensure the power can not be inadvertently energized. Failure to disconnect power before servicing could result in death or serious injury.**

1. Remove power from the controller that has the failed WCI wired to it.
2. Remove the WCI cover by firmly pressing the thumb tab at the bottom of the cover and pulling the cover away from the back plate.  
*Note: If present, remove the security screw before removing the cover.*
3. Detach the 4-connector screw terminal block on the wiring harness from the receptacle on the WCI and remove the WCI.

#### Task 2: Install the new WCI

#### **⚠ WARNING**

#### **Hazardous Voltage!**

**Disconnect all electric power, including remote disconnects before servicing. Follow proper lockout/tagout procedures to ensure the power can not be inadvertently energized. Failure to disconnect power before servicing could result in death or serious injury.**

#### ***New member (non-coordinator) WCI***

4. Set (or verify if pre-addressed) the rotary address switches on the new WCI.
5. Attach the terminal block on the wiring harness to the receptacle on the new WCI and route the wires as before (through either the back plate or the bottom exit port).
6. Restore power to the controller that the WCI is installed on. Use Tracer TU to open the network (**Tools > Wireless > Open Network**) or press the OPEN NET button for 5 seconds. The new WCI should find the network and join it.

#### ***New coordinator WCI when Tracer SC is present***

7. Set (or verify if pre-addressed) the rotary address switches on the new WCI.

## Troubleshooting

---

8. Attach the terminal block on the wiring harness to the receptacle on the new WCI and route the wires as before (through either the back plate or the bottom exit port).
9. If a Tracer SC is present on the network, restore power to the Tracer SC. The network will re-form itself.

### ***New coordinator WCI when no Tracer SC is present***

10. Set (or verify if pre-addressed) the rotary address switches on the new WCI.
11. Attach the terminal block on the wiring harness to the receptacle on the new WCI and route the wires as before (through either the back plate or the bottom exit port).
12. Using a USB cable, connect Tracer TU to another WCI on the network and disband the network (see ["Disbanding a Network," p. 23](#)).
13. Restore power to the controller that the WCI is installed on.
14. Push the START button for 5 seconds or use Tracer TU to re-form the network.

# Appendix: Using the Tracer™ TU Service Tool with Wireless Networks

To monitor, troubleshoot, or make modifications to devices on a wireless network, the Tracer TU service tool must join the network and connect to a device. This appendix describes that process and how to access wireless network management information and functions.

For instructions on using Tracer TU to make changes to a wireless network, see [“Modifying the Network,” p. 22.](#)

## Requirements for Joining

The requirements for joining Tracer TU to a wireless network are:

- Tracer TU version 8.2 (minimum)
- The Tracer TU Communications Adapter installed on the service tool laptop.
  - Note:** For instructions on Tracer TU Communications Adapter installation and best practices, see the current version of X39641157.
- If the network includes a Tracer SC, a user ID and password.

## Joining Tracer TU with a Wireless Network

To join Tracer TU to a wireless network:

1. Locate Tracer™ TU within radio range of any WCI that is a network member.
2. Launch Tracer TU. The **Startup Task Panel** appears ([Figure 14](#)).

**Figure 14. Tracer TU Startup Task Panel**

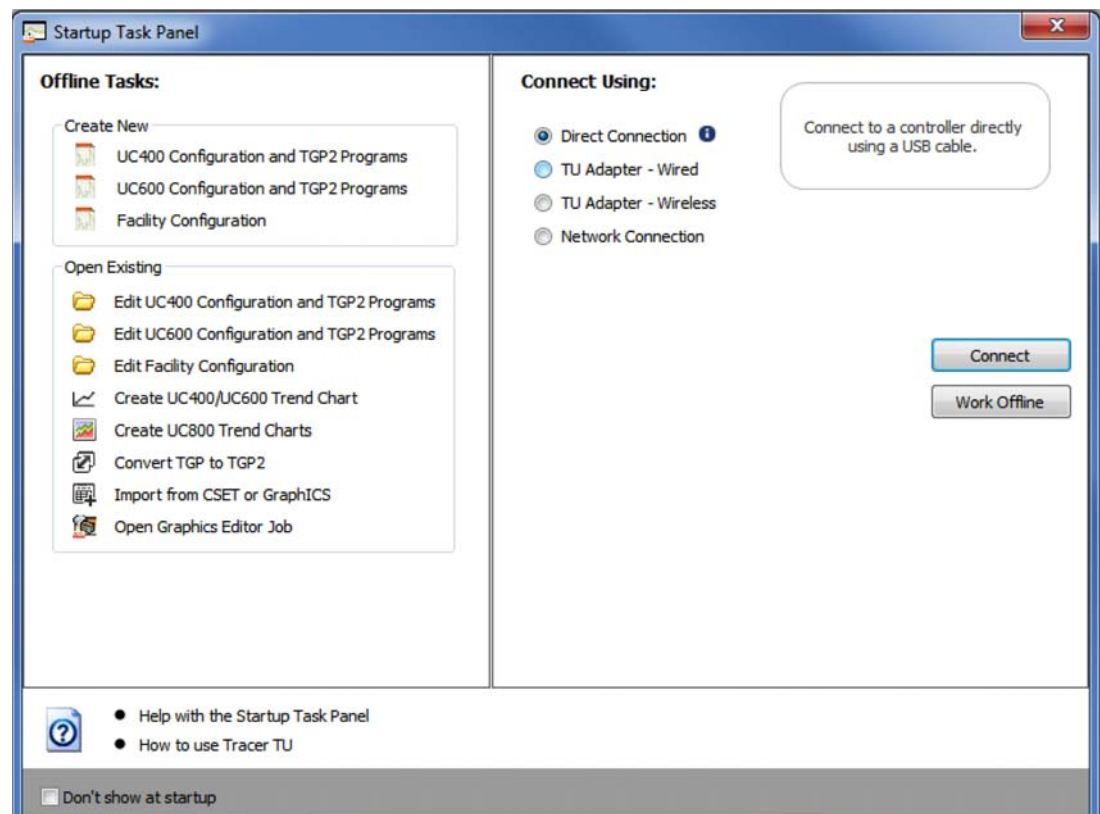

## Appendix: Using the Tracer™ TU Service Tool with Wireless Networks

- On the right side of the **Startup Task Panel**, select **TU Adapter - Wireless** and then click the **Connect** button. The **Wireless Network Utilities** screen appears (Figure 15) showing the group and subnetwork numbers (which correspond to WCI address settings; see “WCI Addressing,” p. 10), and signal strength for all existing wireless networks within radio range of Tracer TU.

**Figure 15. Wireless Network Utilities**

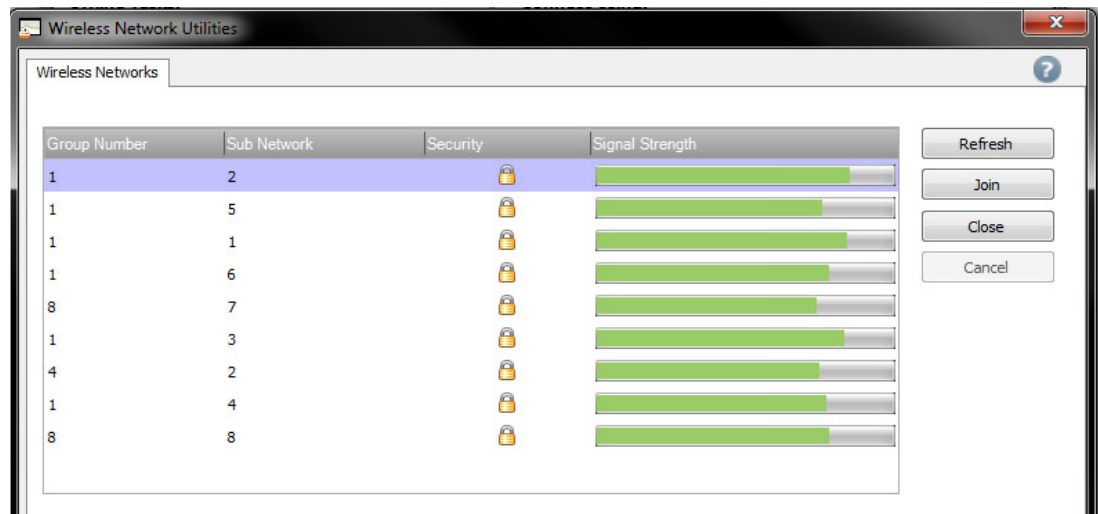

- Select the network you want Tracer TU to join. Click the **Join** button.  
**Note:** Tracer TU can join only one network at a time.
- If a Tracer SC is present on the network, a log-in prompt appears. Enter your ID and password. After log-in, the **Wireless Network Utilities** screen appears as shown in Figure 16.  
**Note:** If no Tracer SC is present on the network, the screen shown in Figure 16 appears without the need to log in.

In the Security column, the lock icon is replaced by a key icon to identify the network that Tracer TU has joined, and two additional tabs appear on the screen.

**Figure 16. Wireless Network Utilities screen after joining the network**

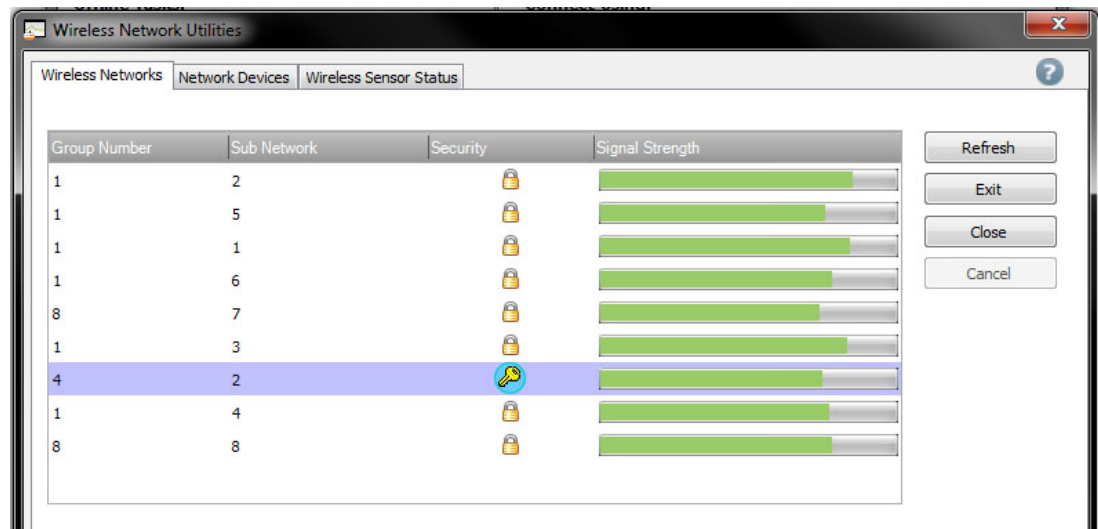

## Managing a Wireless Network and Devices

After communication has been established between Tracer TU and a wireless network, you can manage the network and the devices on it by connecting to a device on the network.

### Connecting to a Device

To connect to a device:

1. From the **Wireless Network Utilities** screen, select the **Network Devices** tab (Figure 17).

Figure 17. Network Devices tab

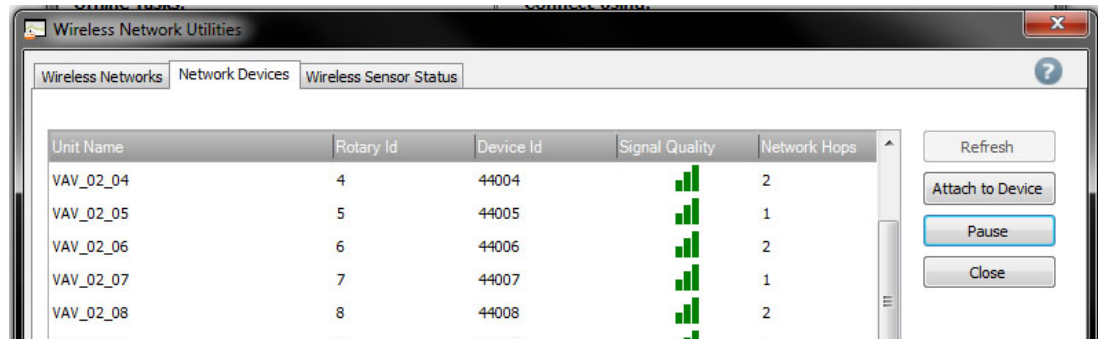

2. Select a device from the list of network devices and click the **Attach to Device** button. The **Unit Summary** screen for the selected device appears (Figure 18) and Tracer TU capabilities are available.

Figure 18. Connected device: Unit Summary screen

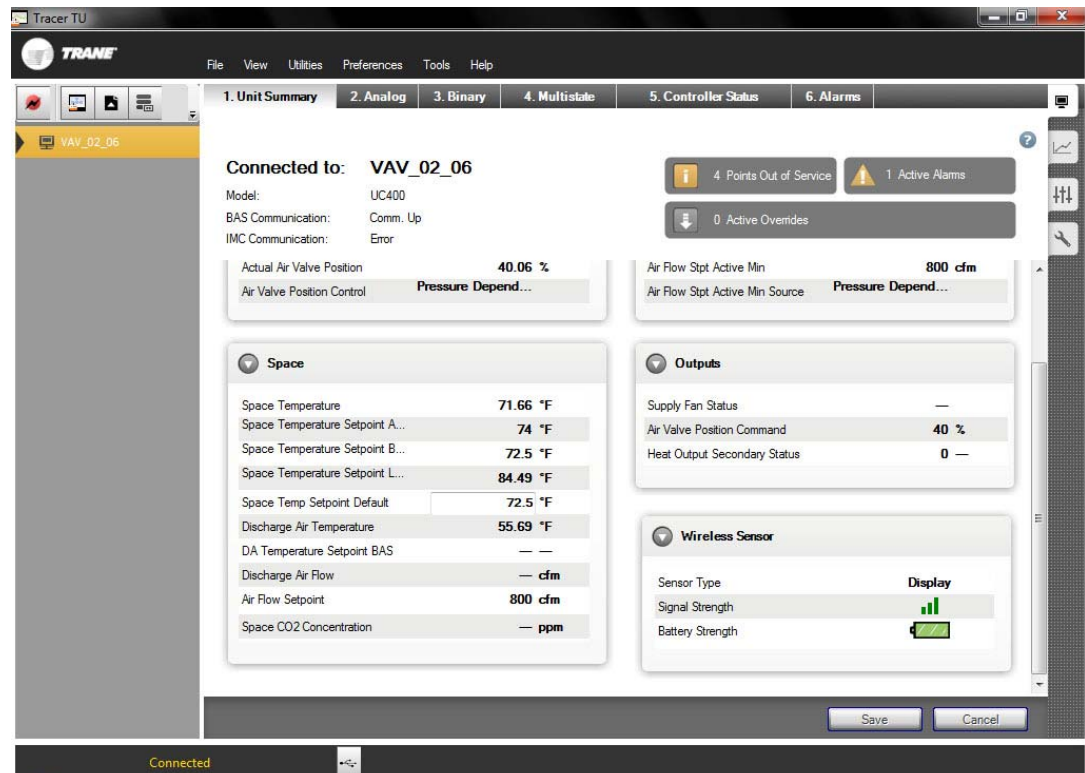

## Wireless Menu

After connecting to a device, a **Wireless** menu becomes available for wireless network management. To access the menu, select **Wireless** from the **Tools** menu.

**Note:** The **Wireless** menu selections vary depending on how TU is connected to the network (wired or wireless) and what functions are available to the connected device. See [Figure 19](#).

**Figure 19. Wireless menu**

a) Wireless connection: Tracer TU attached to a Tracer SC

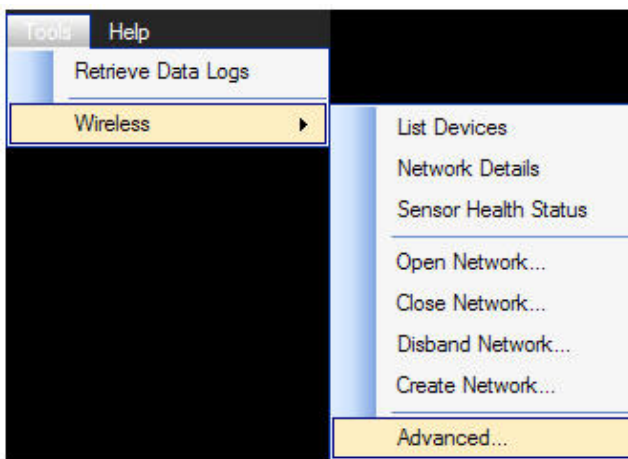

b) Wireless connection: Tracer TU attached to a unit controller

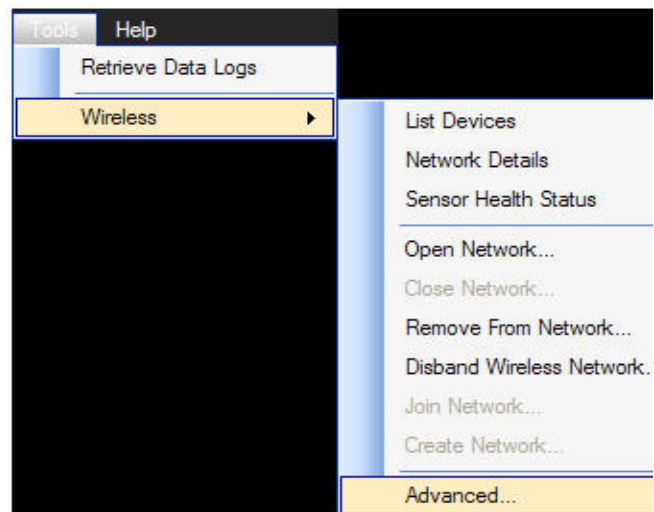

d) Wired network connection: Tracer TU attached to a Tracer SC

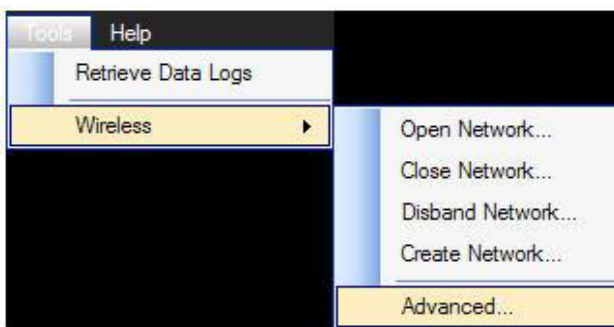

c) Wired network connection: Tracer TU attached to a unit controller

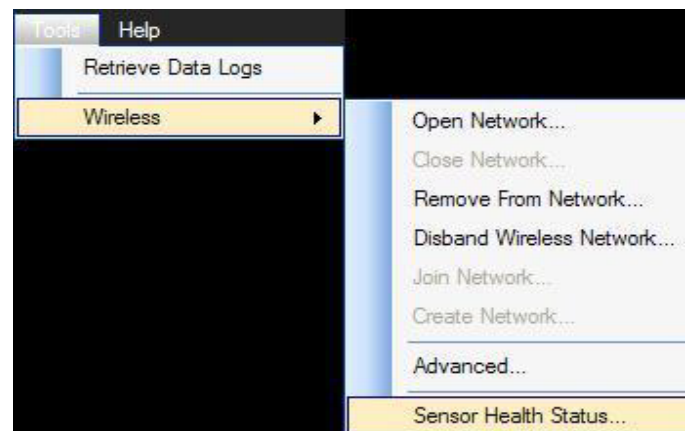

- **List Devices:** An alternate way to view the **Network Devices** tab (see [Figure 17](#)).
- **Network Details:** Opens the **Network Details** tab (see [Figure 20](#)).
- **Sensor Health Status:** An alternate way to view the **Wireless Sensor Status** tab (see [Figure 22](#)).

## Appendix: Using the Tracer™ TU Service Tool with Wireless Networks

- **Open Network:** Select to allow a new member to join. Any WCI with a correct rotary address setting that is located within radio range of the open network will join the network. (Similar to OPEN\_NET button on WCI.)
- **Close Network:** Select to prevent new members from joining the network.
- **Exit Network:** Select to remove the attached device from the network. Only available when TU is attached to a unit controller that belongs to the network.
- **Disband Network:** Select to disband the network.  
**Note:** Tracer TU must be attached to the network coordinator.
- **Join Network:** Select to join the network.
- **Create Network:** Select to create a new network in which the attached device will be network coordinator. (Similar to START button on WCI.)  
**Note:** Typically, used for a unit controller that will be network coordinator when no Tracer SC is present.
- **Advanced:** Opens the **Advanced** tab (see [Figure 21](#)).

**Figure 20. Network Details tab**

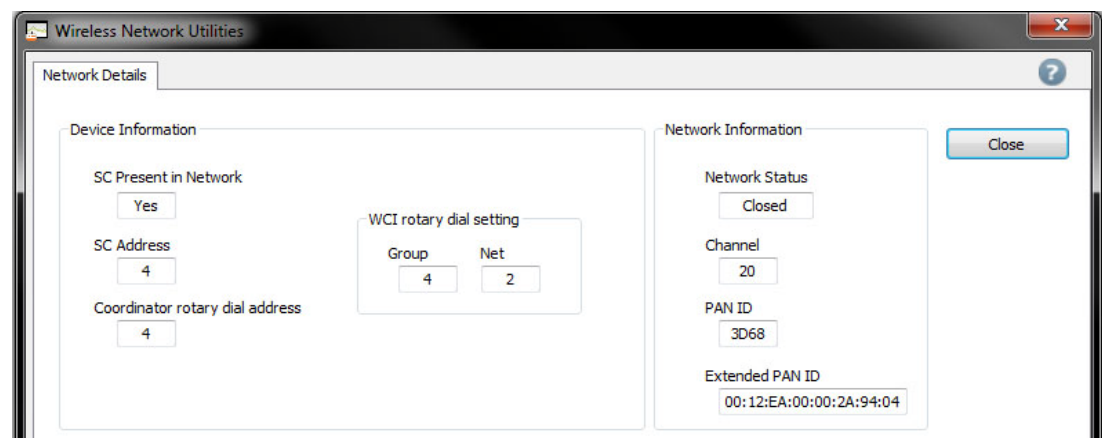

**Figure 21. Wireless Sensor Status tab**

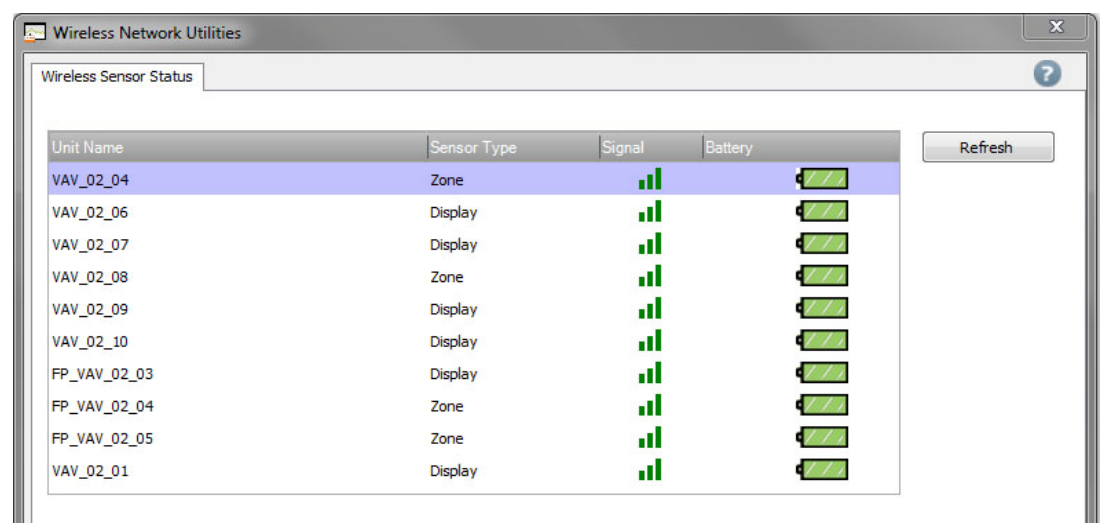

Unit Name	Sensor Type	Signal	Battery
VAV_02_04	Zone	Full Signal	Full Battery
VAV_02_06	Display	Full Signal	Full Battery
VAV_02_07	Display	Full Signal	Full Battery
VAV_02_08	Zone	Full Signal	Full Battery
VAV_02_09	Display	Full Signal	Full Battery
VAV_02_10	Display	Full Signal	Full Battery
FP_VAV_02_03	Display	Full Signal	Full Battery
FP_VAV_02_04	Zone	Full Signal	Full Battery
FP_VAV_02_05	Zone	Full Signal	Full Battery
VAV_02_01	Display	Full Signal	Full Battery

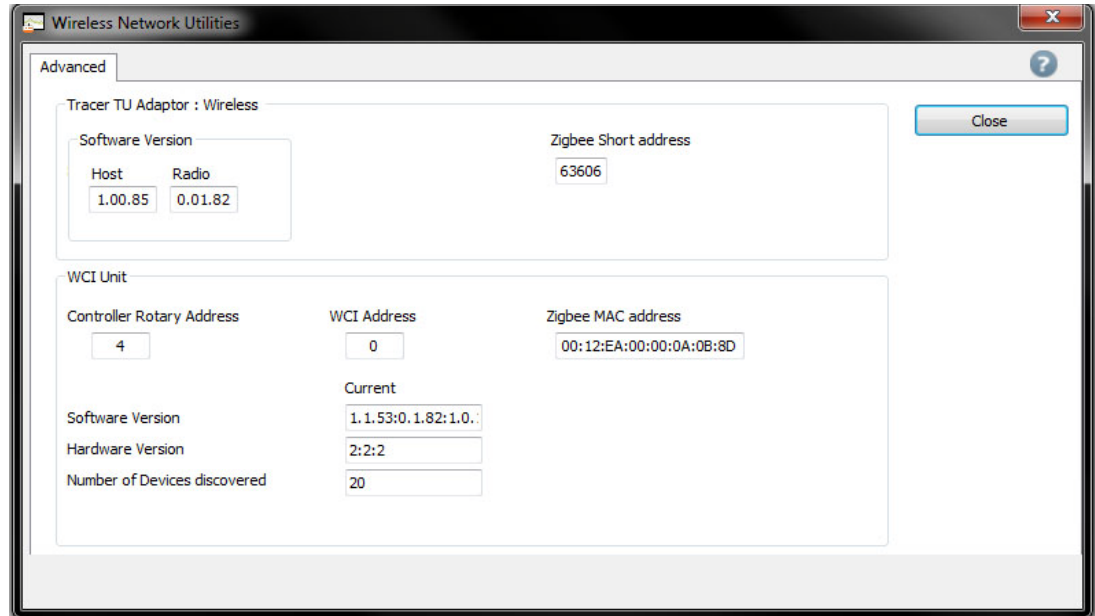
**Figure 22. Advanced tab**

## Wireless Zone Sensor Enable/Disable

If a unit controller's WCI is a zone sensor receiver, the zone sensor is detected and the necessary references are created automatically. The wireless sensor enable/disable setting in the Setup Parameters screen is enabled (checked) by default. However, if a wired sensor is connected to the unit controller, but a wireless sensor is in the area, the wireless sensor has priority and the unit controller may start using the wireless sensor even though a sensor is wired to it. In such a case, you must disable (de-select) the wireless sensor enable/disable setting.

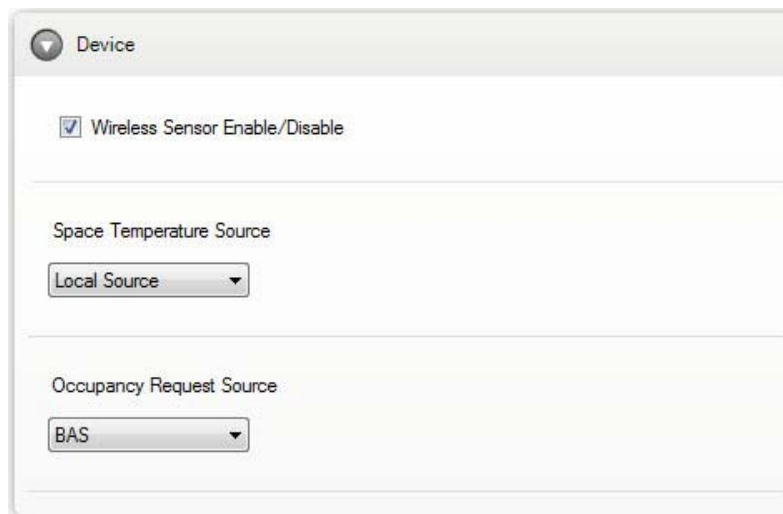
**Figure 23. Wireless sensor enable/disable**











Trane optimizes the performance of homes and buildings around the world. A business of Ingersoll Rand, the leader in creating and sustaining safe, comfortable and energy efficient environments, Trane offers a broad portfolio of advanced controls and HVAC systems, comprehensive building services, and parts. For more information, visit [www.Trane.com](http://www.Trane.com).

Trane has a policy of continuous product and product data improvement and reserves the right to change design and specifications without notice.