

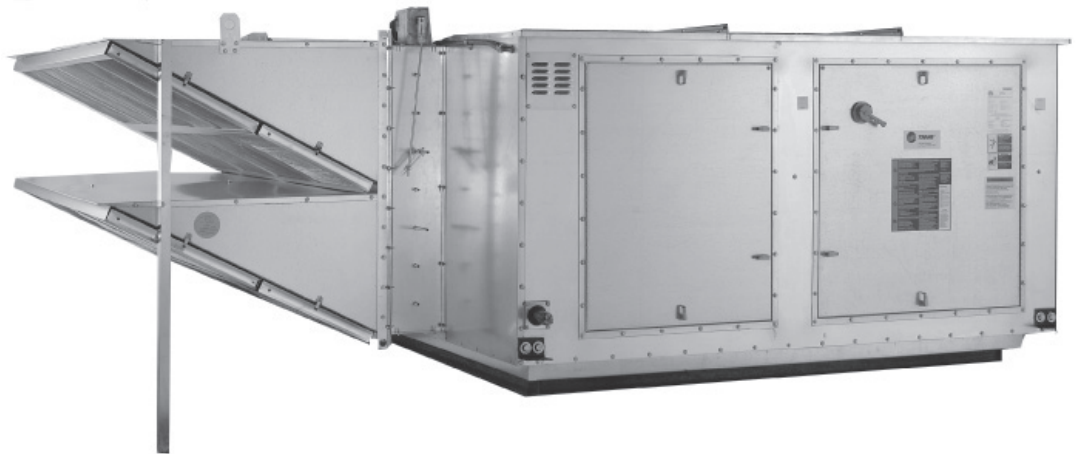

TRANE®

Product Catalog

Direct-Fired Make-Up Air Units



DFIA
DFOA

November 2009

MUA-PRC007-EN



Introduction

Why use Trane Makeup Air Units...

Trane's innovative Direct Fired gas heating systems add warm, fresh and clean air to your work environment for about 20 percent less than the operation and maintenance costs of indirect gas heat.

- **Heats Without Complications:** The Direct Fired gas heating system heats efficiently and cost-effectively using no heat exchanger.
- **Replaces Indoor Air:** The Direct Fired gas heating system replaces indoor air that can become chemical laden in an industrial process or commercial cooling application.
- **Provides Ventilation:** Fresh air is available simply by turning off the heating section.
- **Cleans and Tempers Incoming Air:** The optional filter bank removes airborne particles, and cleaned air is heated to create a more refreshing and comfortable indoor environment.
- Trane offers two styles of Direct Fired gas heating systems:
 - Indoor units (DFIA)
 - Large outdoor units (DFOA)

What Is Make-Up Air?

Make-up air is an outside air supply that is brought in to relieve "air starvation." Without make-up air, a building is under a "negative" condition and the following will occur:

- Backdrafts in natural flues, ventilators and stacks.
- Reduced air volume handled by the exhaust fans and subsequently inadequate removal of contaminants.
- Dispersal of contaminants throughout the work area by high velocity cross-currents from uncontrolled outside air sources.
- Uncomfortable and unhealthy working conditions.
- Pilot outages.

When Is It Required?

Make-up air is required whenever exhaust fans are used. This need for a building "air change" arises when there are:

- Processes which generate contaminants in the form of noxious fumes or dust.
- Activities which create excessive heat or undesirable odors.
- Hazardous material storage areas.
- Ventilation requirements for a building's inhabitants.
- State and local code requirements.

Why Use Make-Up Air Units?

Outside air should not be allowed to drift in through windows, door cracks and other openings, creating a strain on the heating system. Outside air should be controlled, tempered and coordinated with the exhaust by a make-up air unit. The latter is reliable, efficient and does not disrupt building activities.

Why Use Direct Gas-Firing?

Maximum economy is realized with direct gas-firing because the incoming air is heated directly in the burner chamber. This provides 100 percent efficiency (92 percent sensible, 8 percent latent) while eliminating a heat exchanger or combustion chamber that could burn out or corrode.

Trane direct-fired units are factory tested, include the necessary controls for operating the system and generally cost less than alternate systems.

Installation is simple since the unit, (when shipping permits), is shipped as a complete package. The burner is fully modulating, with a minimum firing rate of four percent of full input. This characteristic results in just the right amount of heat under all operating conditions.

Industry Approval

ETL Labeling Requirements

A DFOA/DFIA unit can bear the ETL label if:

- The unit airflow is within the SCFM range shown in [Table 3, p. 18](#) (DFIA) and [Table 12, p. 33](#) (DFOA).
- The fuel is natural gas with a temperature rise not greater than 130°F or the fuel is LP and the temperature rise not greater than 100°F.
- The motor is a single speed motor, or if the motor is a two speed motor, the burner will operate in only one of the two speeds (high or low speed).
- Unit components are standard (there are exceptions to this).
- If the unit has return air, the unit must have a mixing box with the AdaptAire airflow station.

Maximum Emission Levels:

- If the unit has an ETL label, the maximum levels of the products of combustion meet ANSI Z83.18 which are:
 - Carbon Dioxide 4000 ppm
 - Carbon Monoxide 5 ppm
 - Aliphatic Aldehydes 1 ppm
 - Nitrogen Dioxide 0.50 ppm

CETL Labeling Requirements (Canada)

A DFOA/DFIA unit will have a CETL label if the unit meets the first five items of "ETL Labeling Requirements" (above), *AND* the unit does *not* have return air.

Trademarks

Trane and the Trane logo are trademarks of Trane in the United States and other countries. All trademarks referenced in this document are the trademarks of their respective owners.



Table of Contents

Introduction	2
Application Considerations	6
The Need for Make-Up Air Units	6
Outdoor Units	6
What Fuel to Use?	7
Selection Procedure	8
Burner Selection Procedure	9
Unit Configuration	10
Horizontal Configurations	10
Vertical Configurations (DFOA only)	10
Vertical Configurations (DFIA only)	11
DFIA	12
Model Number Descriptions	12
Features and Benefits	14
Reliable Operation	15
Equipment Approval Options	15
Special Construction Features	15
Performance Data	16
Dimensions	21
Weights	26
DFOA	27
Model Number Descriptions	27
Features and Benefits	29
Basic Unit	30
Gas-Fired Unit	30
Performance Data	31
Dimensions	36
Gas Piping	54
Electrical Power	59
Options	60
Motorized 75/25 Damper	60
Mixing Box—Temperature Control	61
Mixing Box—Manual Control	61
Mixing Box—Building Pressure Control	63
Motorized Inlet Damper	63
Exhaust Interlock	64

UV Flame Sensor (UV Mini-Peeper)	65
Optional Gas Controls	65
Factory Installed Options	65
Additional Options*	66
Additional Factory Installed Options	67
Field Installed Accessories	68
Mechanical Specifications	70

Application Considerations

The Need for Make-Up Air Units

When more air is exhausted from a building than is supplied by the mechanical systems, the building is under a “negative” condition. Air will leak into the building through cracks, windows, and doors.

- Make-up air units are typically used to compensate for air being exhausted from a building or other structure.
- Application for closed systems such as ovens or paint booths (consult home office).
- For use as a door heater where outside air is heated and not prevented from infiltrating.
- The DFOA/DFIA can be used as an air handler, no burner section. Can also be used with DX, electric, CW, HW and steam coils. Contact your Trane representative.

Figure 1. Application and various modular arrangements (DFIA only)

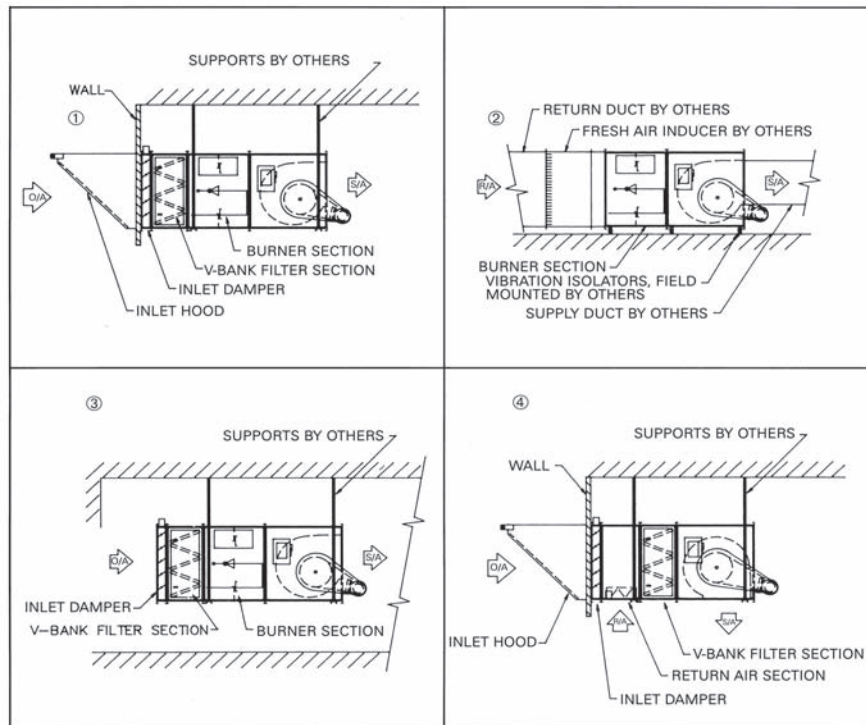

Outdoor Units

Outdoor make-up air units are the most common approach to relieving negative pressure inside commercial and industrial facilities. All units offer the advantage of a full support system that is watertight, provides a plenum for return air, and has easily accessible piping and electrical connections.

When a negative condition exists:

- Flues and stacks may experience a backdraft and cause dangerous contaminants to remain in the occupied space. In the case of flues, the products of combustion may condense and corrode the equipment.
- Under negative conditions, the exhaust system sees a greater static pressure. The capacity of each fan is reduced and this results in an inadequate removal of contaminants.

- Drafts and cross-currents will increase in a negative condition, causing an uncomfortable or unhealthy work environment.

What Fuel to Use?

The most common fuel for heating make-up air is natural gas. This is because 100 percent of the energy goes into the air stream (92 percent sensible, 8 percent latent). Direct firing eliminates the need for heat exchangers or combustion chambers that can corrode or leak. Natural gas is often the least expensive fuel and is usually readily available.

Note: *Selected horizontal and vertical units are available with special coil options (DX, chilled water, steam or electric).*



Selection Procedure

Calculating Total External Static Pressure to Determine Fan Motor Horsepower. To determine the fan motor horsepower, use the following steps:

1. Select Unit
 - Determine cabinet size and cfm
2. Determine Static Pressure of Optional Accessories
 - Add the static pressures of the optional accessories.
3. Determine External Static Pressure
 - Calculate external static pressure of system due to ductwork, grilles, etc. This is the static pressure external to the DFIA/DFOA unit and is up to the system designer to determine.
4. Calculate Total External Static Pressure
 - Add the static pressures of the optional accessories to the external static pressure to determine total external static pressure.
5. Use the [Table 1, p. 16](#) (DFIA) and [Table 10, p. 31](#) (DFOA) to determine the fan motor horsepower.

Example:

1. Specification calls for a 40,000 cfm unit. Select a size 225.
2. Unit will require an inlet hood, inlet damper and a v-bank filter. Therefore, the static pressure of the optional accessories is 0.51 in. wc.

Fresh air inlet hood and birdscreen	0.13 in. wc
Motor operated inlet damper	0.13 in. wc
V-bank filter section	0.25 in. wc
<hr/>	
Static pressure of optional accessories	0.51 in. wc

3. Engineer has determined that the external static pressure due to the ductwork is 0.75 in. wc.

4. Static Pressure of optional accessories	0.51 in. wc
External static pressure	0.75 in. wc
<hr/>	
Total External Static Pressure	1.26 in. wc

5. For a size 225 unit at 40,000 cfm and 1.26 in. total external static pressure, a 30 hp fan motor will be required.

Burner Selection Procedure

For DFIA selections, use [Table 3, p. 18](#), and select next size larger available burner. For DFOA selections, use [Table 12, p. 33](#).

Note: Table is based on an entering air temperature of -40°F.

Example: an 80°F temperature rise is desired for 18000 scfm.

The table shows a MBh input of 1788 MBh.

Select the 1925 MBh input burner (Digit 14, 15 = AH)

OR

Use the following formula:

$$\text{MBh input} = \frac{(0.6210 \times \text{scfm} \times \text{TR})}{(460 + 80 + 10)}$$

$$(0.6210 \times) / (460 + \text{TR} + \text{EAT})$$

where:

TR = Temperature Rise (Desired leaving air temperature – entering air temperature)

EAT = Temperature Rise (Desired leaving air temperature – entering air temperature)

Example: A desired leaving air temperature of 90°F is required for 18000 scfm.

The entering air temperature is 10°F.

Temperature rise (TR) = 90 – 10 = 80°F

$$\text{MBh input} = \frac{(0.6210 \times 18000 \times 80)}{(460 + 80 + 10)} = 1626 \text{ MBh input}$$

Select the 1650 MBh input burner (Digit 14, 15 = AG)

Unit Configuration

Horizontal Configurations

For all arrangements shown, controls, gas piping and fan motor are on the near side. Selected horizontal units are available with special options — cooling coils (DX, chilled water), steam and electric coils, no burner section. Contact your Trane representative for availability and pricing.

Figure 2. Horizontal configurations

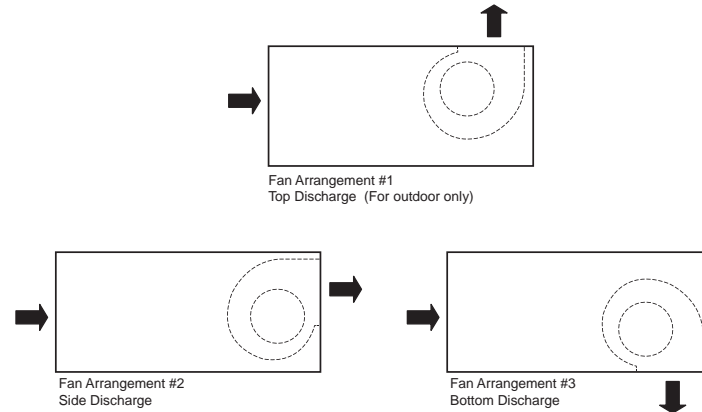

Vertical Configurations (*DFOA only*)

For all arrangements shown, the gas piping and controls are on the near side. Selected vertical units are available with special options — steam and electric coils, no burner section.

Figure 3. Vertical configuration (*DFOA only*)

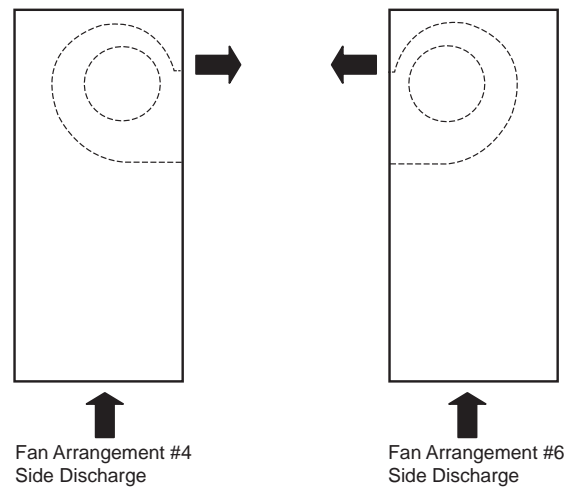

Vertical Configurations (*DFIA only*)

For all arrangements shown, the gas piping is on the near side. The electric control cabinet (EC) and disconnect are on the side opposite the air entering side. Selected vertical units are available with special options – steam and electric coils, no burner section. Contact your Trane representative for availability.

Figure 4. Vertical configurations (*DFIA only*)

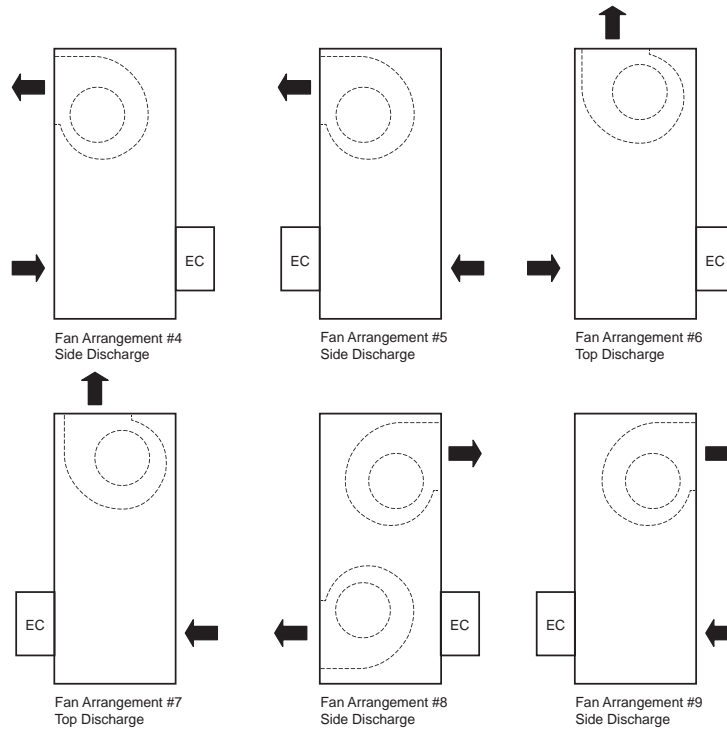



DFIA

Model Number Descriptions

Digit 1, 2, 3 – Unit Description

DFI = Direct fired indoor unit

Digit 4 – Development Sequence

A = First Generation

Digit 5 – Unit Size

109	120	215	225
112	122	218	230
115	125	220	
118	130	222	

Digit 8 – Burner Section

0 = No Burner Section
1 = Burner Section

Digit 9 – Main Power Supply

A = 115/60/1	D = 208/60/3
B = 230/60/1	E = 230/60/3
C = 208/60/1	F = 460/60/3

Digit 10 – Design Sequence

H = Eighth Design

Digit 11 – Fuel

N = Natural Gas
P = LP (Propane) Gas

Digit 12 – Gas Control Option

E = Modulating Discharge Temp Control (MDT)
F = Modulating Room Temp Control (MRT)
G = Modulating Room Temp Control & Pro Room Sensor (MRT Pro)
H = Modulating Room Temp Control & BACview® (MRT Expert)

Digit 13 – Gas Train Approvals

0 = No Selection
1 = Standard Gas Train
3 = IRI Gas Train Approval (ETL)
4 = FM Gas Train Approval (ETL)
5 = IRI Gas Train Approval (No ETL)
6 = FM Gas Train Approval (No ETL)

Digit 14, 15 – Burner Input Rating (Natural Gas/Propane)

00 = No Burner Input Selection
AA = 275/225 MBh
AB = 550/450 MBh
AC = 825/885 MBh
AE = 1100/1125 MBh
AF = 1375/1350 MBh
AG = 1650/1575 MBh
AH = 1925/1800 MBh
AJ = 2200/2025 MBh
AK = 2475/2475 MBh
AL = 2750/2700 MBh
AN = 3025/2925 MBh
AP = 3300/3150 MBh
AQ = 3575/3375 MBh
AR = 3850/3825 MBh
AT = 4125/4050 MBh
AV = 4400/4275 MBh
AW = 4675/4500 MBh
AX = 4950/4950 MBh
AY = 5225/5175 MBh
AZ = 5500/5400 MBh
A1 = 5775/5624 MBh
A2 = 6050/5850 MBh
A3 = 6325/6075 MBh
A4 = 6600/6525 MBh
A5 = 6875/6750 MBh
A6 = 7150/6975 MBh
A7 = 7425/7425 MBh
A8 = 7700/7650 MBh
A9 = 7975 MBh
BA = 8250 MBh
BB = 8525 MBh
BC = 8800 MBh
BD = 9075 MBh

Digit 16 – Blower Motor Horsepower

0 = No Selection
B = 3/4 hp
C = 1 hp
D = 1-1/2 hp
E = 2 hp
F = 3 hp
G = 5 hp
H = 7-1/2 hp
J = 10 hp
K = 15 hp
L = 20 hp
M = 25 hp
P = 30 hp
Q = 40 hp
R = 50 hp
T = 60 hp

Digit 17 – Motor Speed and Starter

0 = No Selection
1 = Single Speed odp 1800 rpm
2 = Single Speed tefc 1800 rpm
3 = Single Speed Ener. Effic odp
4 = Single Speed Ener. Effic tefc
5 = 2s1w odp 1800/900 rpm
6 = 2s2w odp 1800/1200 rpm

Digit 18 – Fan Arrangement

1 = Horizontal Arrangement 1 Top
2 = Horizontal Arrangement 2 Side
3 = Horizontal Arrangement 3 Bottom
4 = Vertical Arrangement 4 Side
5 = Vertical Arrangement 5 Side
6 = Vertical Arrangement 6 Top
7 = Vertical Arrangement 7 Top
8 = Vertical Arrangement 8 Side
9 = Vertical Arrangement 9 Side

Digit 20 – V-Bank Filter Section

0 = No V-Bank Filter Section
A = V-Bank Section with Permanent Filters
B = V-Bank Section without Permanent Filters
C = V-Bank Section with TA Filters
D = V-Bank Section with Pleated Filters

Digit 21 – Dampers/Mixing Box

0 = No Damper/Mixing Box Selected (No ETL)
A = Motorized Return Air Damper (No ETL)
B = Motorized Damper 75/25 (No ETL)
C = Mixing Box - Temperature Control (No ETL)
D = Mixing Box - Building Press Control (No ETL)
E = Mixing Box - Manual Control (No ETL)
F = Mixing Box with Airflow Station - Manual Control (ETL)
G = Mixing Box with Airflow Station - Temp Control (ETL)
H = Mixing Box with Airflow Station - Bldg. Press Control (ETL)

Digit 22, 23 – Controls Opposite from Standard

** = Standard Controls
AA = Controls Opposite from Standard

Digit 24, 25 – Motorized Inlet Damper

** = No Motorized Inlet Damper
AB = Motorized Inlet Damper

Digit 26, 27 – Insulation

AC = Insulation on Entire Unit (Include Filter)

Digit 28, 29 – 115V Duplex Service Receptable with Trans.

AJ = 115V Duplex Service Receptacle with Trans.

Digit 30, 31 – Painted Cabinet

AZ = Painted Cabinet

DIGIT 32, 33 – UV Flame Sensor

AL = Ultraviolet (UV) Flame Sensor

Digit 34, 35 – Clogged Filter Indicator

AN = Clogged Filter Indicator

Digit 36, 37 – Exhaust Interlock

AP = Exhaust Interlock

Digit 38, 39 – Interlocking Relay

AQ = Interlocking Relay

Digit 40, 41 – Omit Disconnect Switch

DS = Disconnect Switch

AT = Omit Disconnect Switch

Digit 42, 43 – High Gas Pressure Regulator

CA = High Gas Press Reg 0.5–1 psi

AV = High Gas Press Reg –5 psi

AW = High Gas Press Reg 5–10 psi

BH = High Gas Press Reg Over 10 psi

Digit 44, 45 – Adjustable Drive

AX = Adjustable Drive

Digit 46, 47 – Low Gas Pressure Burner

BJ = Low Gas Pressure Burner

Digit 48, 49 – Vibration Options

A5 = Vibration Feet

A6 = Vibration Hangers

Digit 50, 51 – Control Options

BD = 7-Day Time Clock

BG = On/off Night Setback Thermostat

BF = BACview[®] Remote Panel

Digit 52, 53 – Discharge Louver

AY = Discharge Louver

0 = None

Features and Benefits

Figure 5. DFIA features and benefits

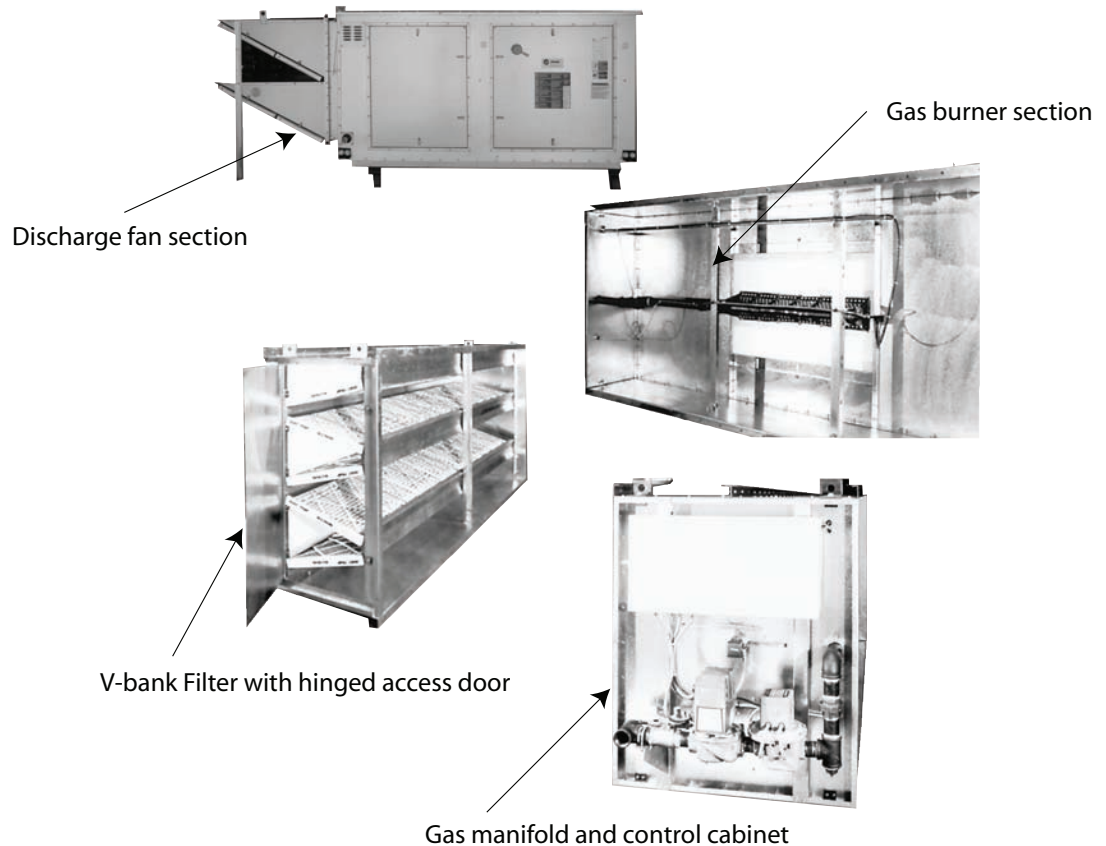

Feature: Basic unit is factory assembled and wired.

Benefit: Reduces field installation cost.

Feature: Factory tested.

Benefit: Eliminates majority of field start-up problem caused by defective controls.

Feature: Adjustable motor mount.

Benefit: Belt tension can be field adjusted for maximum belt life.

Feature: All fuses factory furnished.

Benefit: Delay at start-up eliminated.

Feature: Return air cycle capability.

Benefit: Return air cycle results in fuel economy for pressurized heating systems and eliminates need for two-speed fan operation. Minimizes heating cost.

Feature: No flues or stacks are used.

Benefit: Eliminates backdraft and dangerous contaminants from entering the space.

Reliable Operation

The standard unit includes all of the controls needed for trouble-free operation.

If the designer does not utilize a master panel for consolidating mechanical equipment, an optional remote control station should be ordered.

This device includes switches and signal lights for operating the make-up air unit and monitoring its performance from any convenient location.

While rare, malfunctions can occur because a belt breaks, local power is interrupted or a component fails. If this should happen, the unit's control system is designed to take over. Its overlapping fail-safe protective devices will turn on an alarm light and prevent burner operation until the problem has been corrected.

Because of this attention to detail, combustion will be clean and odorless under the most adverse conditions. The incoming "make-up air" will be at least five times purer than the requirements set down by the U.S. Bureau of Standards.

Equipment Approval Options

Owners and specifiers have three very important reasons for wanting equipment approvals. One reason is to establish a manufacturer's reliability.

A second looks for conformance with equipment standards if any have been established for the particular product. And finally, there may be requirements set down by an industrial user's insurance carrier.

Trane has gone to great lengths to satisfy these needs. In the first case, reliability is established for our standard unit through conservative design and the use of U.L. listed components.

For industrial applications, the unit can also be furnished with special gas controls to comply with FM or IRI. The latter is available for applications where the exact insurance approval agency has not been established.

Special Construction Features

- External bearings for easy service and lubrication.
- External motor for ease of service and belt maintenance.
- Hollow fan shaft on double blower models eliminate the need for a center bearing which is difficult to service.
- Enlarged filter sections increasing filter life and reducing service time.
- Hinged filter access door.
- Service platform available as an option for easy maintenance on suspended units.



DFIA

Performance Data

Table 1. Direct-Fired Indoor Air (DFIA) unit—General data

Unit Size	109	112	115	118	120	122	125	130	215	218	220	222	225	230
Airflow														
Min. Airflow (cfm)	1600	3250	4500	6500	9000	11000	14000	22000	9000	12500	18000	25000	30000	44000
Max. Airflow (cfm)	3000	4250	6000	8500	11000	15000	20000	30000	12000	17000	26000	31000	46000	64000
Fan														
Quantity - Wheel Size	1 - 9	1 - 12	1 - 15	1 - 18	1 - 20	1 - 22	1 - 25	1 - 30	2 - 15	2 - 18	2 - 20	2 - 22	2 - 25	2 - 30
Motor (hp)	1-5	1.5-5	2-7.5	3-10	5-10	5-15	7.5-20	10-30	5-15	7.5-20	7.5-25	15-30	15-50	20-60
Filters, 2-in														
Quantity	4	4	9	9	10	10	24	24	18	18	35	35	42	42
Size (in)	20x20	20x20	20x16	20x16	20x25	20x25	20x16	20x16	20x15	20x15	20x16	20x16	20x20	20x20

Table 2. Direct-Fired Indoor Air (DFIA) unit—Performance data

Models DFI	Blower Size (in.)	CFM Std Air at 70	FPM Outlet Velocity	Total External Static Pressure (in. wc)							
				1/4	3/8	1/2	3/4	1	1-1/4	1-1/2	2
Horsepower											
109	1-9	1600	1914	1	1	1	1	—	—	—	—
		1900	2273	1	1	1-1/2	1-1/2	1-1/2	1-1/2	2	—
		2200	2632	1-1/2	1-1/2	1-1/2	1-1/2	2	2	2	3
		2600	3110	2	2	2	2	3	3	3	3
		3000	3589	3	3	3	3	3	3	3	3
112	1-12	3250	2257	1-1/2	2	2	2	2	3	3	3
		3500	2431	2	2	2	2	3	3	3	5
		3750	2604	2	2	3	3	3	3	3	5
		4000	2778	3	3	3	3	3	3	5	5
		4250	2951	3	3	3	3	3	5	5	5
115	1-15	4500	2239	2	2	3	3	3	3	5	—
		5000	2488	3	3	3	3	3	5	5	5
		5500	2736	3	3	3	3	5	5	5	5
		6000	2985	3	5	5	5	5	5	5	7-1/2
118	1-18	6500	2265	3	5	5	5	5	5	5	7-1/2
		7000	2439	5	5	5	5	5	5	7-1/2	7-1/2
		7500	2613	5	5	5	5	5	7-1/2	7-1/2	7-1/2
		8000	2787	5	5	5	5	7-1/2	7-1/2	7-1/2	7-1/2
		8500	2962	5	5	5	7-1/2	7-1/2	7-1/2	7-1/2	10
120	1-20	9000	2143	5	5	5	5	7-1/2	7-1/2	7-1/2	—
		9500	2262	5	5	5	7-1/2	7-1/2	7-1/2	7-1/2	—
		10000	2381	5	5	5	7-1/2	7-1/2	7-1/2	7-1/2	10
		10500	2500	5	7-1/2	7-1/2	7-1/2	7-1/2	7-1/2	10	10
		11000	2619	7-1/2	7-1/2	7-1/2	7-1/2	7-1/2	10	10	10

Note: Use the following static pressures for the optional accessories:

1. Motor Operated Inlet Damper: 0.13 in. wc
2. V-Bank Filter Section: 0.25 in. wc
3. Mixing Box: 0.40 in. wc
4. Discharge Louver: 0.13 in. wc

Table 2. Direct-Fired Indoor Air (DFIA) unit—Performance data (continued)

Models DFI	Blower Size (in.)	CFM Std Air at 70	FPM Outlet Velocity	Total External Static Pressure (in. wc)							
				1/4	3/8	1/2	3/4	1	1-1/4	1-1/2	2
122	1-22	11000	2157	5	5	7-1/2	7-1/2	7-1/2	7-1/2	10	—
		12000	2353	7-1/2	7-1/2	7-1/2	7-1/2	7-1/2	10	10	15
		13000	2549	7-1/2	7-1/2	7-1/2	10	10	10	10	15
		14000	2745	7-1/2	10	10	10	10	15	15	15
		15000	2941	—	10	10	10	15	15	15	15
125	1-25	14000	2086	7-1/2	7-1/2	7-1/2	7-1/2	10	—	—	—
		15000	2235	7-1/2	7-1/2	7-1/2	10	10	10	15	—
		16000	2385	7-1/2	7-1/2	7-1/2	10	10	15	15	—
		18000	2683	10	10	10	10	15	15	15	15
		20000	2981	15	15	15	15	15	15	15	20
130	1-30	22000	2486	10	10	10	15	15	15	15	—
		24000	2581	10	15	15	15	15	15	20	20
		26000	2796	15	15	15	15	20	20	20	25
		28000	3011	15	15	15	20	20	20	20	25
		30000	3226	20	20	20	20	20	25	25	30
215	2-15	9000	2239	5	5	5	5	5	—	—	—
		9500	2363	5	5	5	5	7-1/2	7-1/2	—	—
		10000	2488	5	5	5	7-1/2	7-1/2	7-1/2	7-1/2	—
		10500	2612	5	5	7-1/2	7-1/2	7-1/2	7-1/2	7-1/2	—
		11000	2736	5	7-1/2	7-1/2	7-1/2	7-1/2	7-1/2	10	10
		11500	2861	7-1/2	7-1/2	7-1/2	7-1/2	7-1/2	10	10	10
		12000	2985	7-1/2	7-1/2	7-1/2	7-1/2	10	10	10	15
218	2-18	12500	2178	7-1/2	7-1/2	7-1/2	7-1/2	7-1/2	—	—	—
		13000	2265	7-1/2	7-1/2	7-1/2	7-1/2	10	10	—	—
		14000	2439	7-1/2	7-1/2	7-1/2	10	10	10	15	—
		15000	2613	7-1/2	10	10	10	10	15	15	15
		16000	2787	10	10	10	10	15	15	15	15
		17000	2962	10	10	10	15	15	15	15	20
220	2-20	18000	2143	7-1/2	10	10	10	15	15	15	—
		19000	2262	10	10	10	10	15	15	15	—
		20000	2381	10	10	10	15	15	15	15	20
		21000	2500	10	15	15	15	15	15	20	20
		22000	2619	15	15	15	15	15	15	20	20
		23000	2738	15	15	15	15	15	20	20	20
		24000	2857	15	15	15	15	20	20	20	25
		25000	2976	15	15	15	20	20	20	20	25
		26000	3095	15	20	20	20	20	20	25	25

Note: Use the following static pressures for the optional accessories:

1. Motor Operated Inlet Damper: 0.13 in. wc
2. V-Bank Filter Section: 0.25 in. wc
3. Mixing Box: 0.40 in. wc
4. Discharge Louver: 0.13 in. wc



DFIA

Table 2. Direct-Fired Indoor Air (DFIA) unit—Performance data (continued)

Models DFI	Blower Size (in.)	CFM Std Air at 70	FPM Outlet Velocity	Total External Static Pressure (in. wc)							
				1/4	3/8	1/2	3/4	1	1-1/4	1-1/2	2
222	2-22	25000	2451	15	15	15	15	20	20	20	25
		26000	2549	15	15	15	20	20	20	20	25
		27000	2647	15	15	15	20	20	20	25	25
		28000	2745	15	20	20	20	20	25	25	30
		29000	2843	20	20	20	20	25	25	25	30
		30000	2941	20	20	20	20	25	25	25	30
		31000	3039	20	20	20	25	25	25	30	30
225	2-25	30000	2235	15	15	15	15	20	20	—	—
		32000	2385	15	15	15	20	20	25	25	—
		34000	2534	15	20	20	20	20	25	25	30
		36000	2683	20	20	20	20	25	25	30	30
		38000	2832	20	20	20	25	25	30	30	40
		40000	2981	20	25	25	25	30	30	30	40
		42000	3130	25	25	25	30	30	30	40	40
		44000	3279	25	30	30	30	40	40	40	40
230	2-30	46000	3428	30	30	30	40	40	40	40	50
		44000	2366	20	20	20	25	25	30	—	—
		48000	2581	20	25	25	25	30	30	40	—
		52000	2796	25	25	30	30	40	40	40	50
		56000	3011	30	30	30	40	40	40	40	50
		60000	3226	30	40	40	40	40	50	50	50

Note: Use the following static pressures for the optional accessories:

1. Motor Operated Inlet Damper: 0.13 in. wc
2. V-Bank Filter Section: 0.25 in. wc
3. Mixing Box: 0.40 in. wc
4. Discharge Louver: 0.13 in. wc

Table 3. Direct-Fired Indoor Air (DFIA) unit—Burner selection table (MBh)

DFIA Model	CFM Std. Air							
	70°	70° Rise	80° Rise	90° Rise	100° Rise	110° Rise	120° Rise	130° Rise
109	1600	142	159	175	191	206	221	235
	1900	169	189	208	227	245	262	279
	2200	195	219	241	263	284	304	323
	2600	231	258	285	311	335	359	382
	3000	266	298	329	358	387	414	440
112	3250	288	323	356	388	419	449	477
	3500	311	348	384	418	451	483	514
	3750	333	373	411	448	483	518	550
	4000	355	397	438	478	516	552	587
	4250	377	422	466	508	548	587	624

Table 3. Direct-Fired Indoor Air (DFIA) unit—Burner selection table (MBh) (continued)

DFIA Model	CFM Std. Air							
	70°	70° Rise	80° Rise	90° Rise	100° Rise	110° Rise	120° Rise	130° Rise
115	4500	399	447	493	537	580	621	661
	5000	444	497	548	597	644	690	734
	5500	488	546	603	657	709	759	807
	6000	532	596	658	717	773	828	881
118	6500	577	646	712	776	838	897	954
	7000	621	696	767	836	902	966	1027
	7500	616	704	792	880	968	1057	1101
	8000	710	795	877	955	1031	1104	1174
	8500	754	845	932	1015	1096	11733	1248
120	9000	798	894	986	1057	1160	1242	1321
	9500	798	894	986	1057	1160	1242	1321
	10000	887	994	1096	1194	1289	1380	1468
	10500	863	986	1109	1233	1356	1479	1541
	11000	976	1039	1205	1314	1418	1518	1615
122	11000	976	1039	1205	1314	1418	1518	1615
	12000	1065	1192	1315	1433	1547	1656	1761
	13000	1153	1292	1425	1553	1676	1794	1908
	14000	1242	1391	1534	1672	1804	1932	2055
	15000	1331	1409	1644	1791	1933	2070	2202
125	14000	1242	1391	1534	1672	1804	1932	2055
	15000	1331	1409	1644	1791	1933	2070	2202
	16000	1419	1590	1753	1911	2062	2208	2349
	17000	1508	1689	1863	2030	2191	2346	2495
	18000	1597	1788	1973	2150	2320	2484	2642
	20000	1774	1987	2192	2388	2578	2760	2936
130	22000	1952	2186	2411	2627	2836	3036	3229
	24000	2129	2385	2630	2866	3093	3312	3523
	26000	3207	2583	2849	3105	3351	3588	3816
	28000	2484	2782	3069	3344	3609	3864	4110
	30000	2661	2981	3288	3583	3867	4140	4404
215	9000	798	894	986	1057	1160	1242	1321
	9500	798	894	986	1057	1160	1242	1321
	10000	887	994	1096	1194	1289	1380	1468
	10500	863	986	1109	1233	1356	1479	1541
	11000	976	1039	1205	1314	1418	1518	1615
	11500	1020	1143	1260	1373	1482	1587	1688
	12000	1065	1192	1315	1433	1547	1656	1761
218	13000	1153	1292	1452	1553	1676	1794	1908
	14000	1242	1319	1534	1672	1804	1932	2055
	15000	1331	1490	1644	1791	1933	2070	2202
	16000	1419	1590	1753	1911	2062	2208	2349
	17000	1508	1689	1863	2030	2191	2346	2495



DFIA

Table 3. Direct-Fired Indoor Air (DFIA) unit—Burner selection table (MBh) (continued)

DFIA Model	CFM Std. Air							
	70°	70° Rise	80° Rise	90° Rise	100° Rise	110° Rise	120° Rise	130° Rise
220	18000	1597	1788	1973	2105	2320	2484	2642
	19000	1686	1888	2082	2269	2449	2622	2789
	20000	1774	1987	2192	2388	2578	2760	2936
	21000	1726	1972	2219	2465	2712	2958	3082
	22000	1952	2186	2411	2627	2836	3036	3229
	23000	2040	2285	2521	2747	2964	3174	3376
	24000	2129	2385	2630	2866	3093	3312	3523
	25000	2218	2484	2740	2986	3222	3450	3670
	26000	2307	2583	2849	3105	3351	3588	3816
222	25000	2218	2484	2740	2986	3222	3450	3670
	26000	2307	2583	2849	3105	3351	3588	3816
	27000	2395	2683	2959	3224	3480	3726	3963
	28000	2484	2782	3069	3344	3609	3864	4110
	29000	2573	2881	3178	3404	3745	4085	4257
	30000	2465	2817	3178	3463	3738	4002	4257
	31000	2750	3080	3397	3702	3996	4278	4550
225	30000	2661	2981	3288	3583	3867	4140	4404
	32000	2839	3180	3507	3822	4124	4416	4697
	34000	3016	3378	3726	4060	4382	4692	4991
	36000	3194	3577	3945	4299	4640	4968	5284
	38000	3371	3776	4164	4538	4898	5544	5578
	40000	3549	3974	4384	4777	5156	5520	5871
	42000	3451	3944	4437	4930	5423	5917	6165
	44000	3903	4372	4822	5255	5671	6072	6458
46000	4081	4571	5041	5494	5929	6348	6752	
230	44000	3903	4372	4822	5255	5671	6072	6458
	48000	4258	4769	5260	5732	6187	6624	7046
	52000	4613	5167	5699	6210	6702	7176	7633
	56000	4968	5564	6317	6688	7218	7728	8220
	60000	5323	5962	6575	7165	7733	8280	8807
	64000	5678	6359	7014	7643	8249	8832	9394

Dimensions

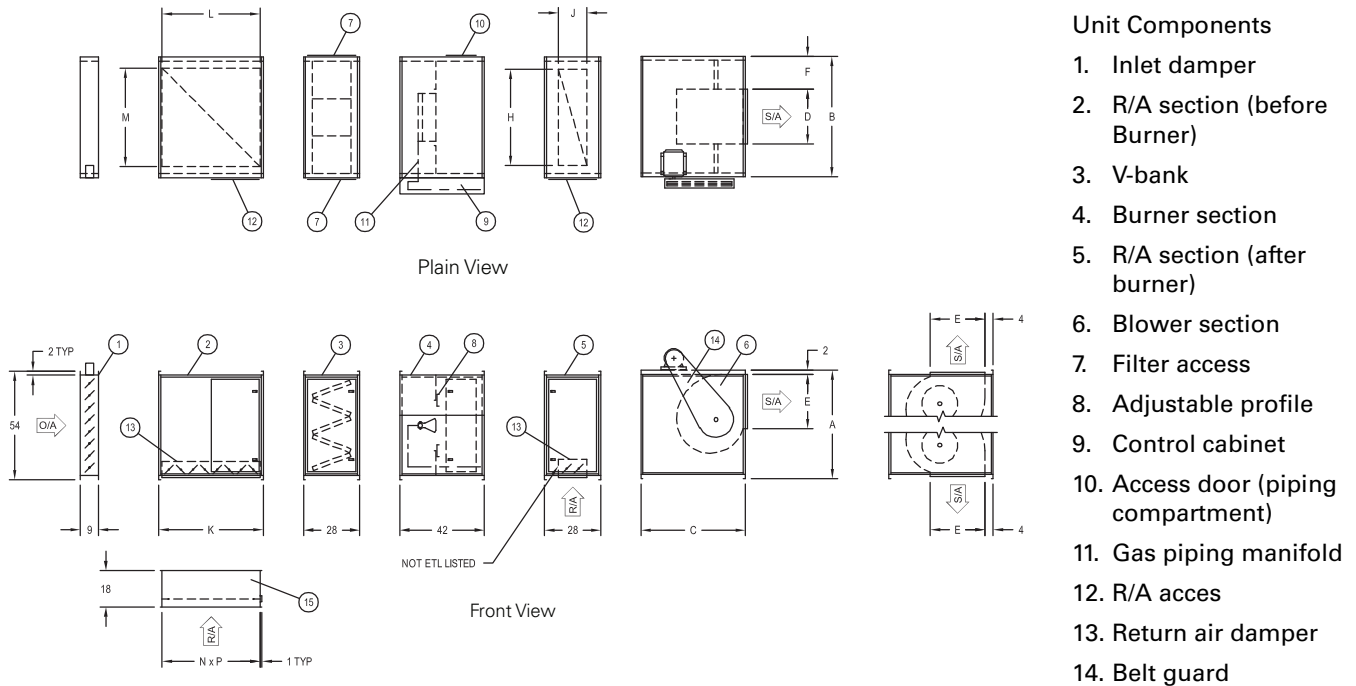
Figure 6. Horizontal arrangement single blower

Unit Components

1. Inlet damper
2. R/A section (before Burner)
3. V-bank
4. Burner section
5. R/A section (after burner)
6. Blower section
7. Filter access
8. Adjustable profile
9. Control cabinet
10. Access door (piping compartment)
11. Gas piping manifold
12. R/A acces
13. Return air damper
14. Belt guard

Table 4. Dimensions for horizontal arrangement—Single blower DFIA

Model	A	B	C	D	E	F	H	J	K	L	M	N	P
109	29	45	33	12	10-1/2	16-1/2	30	8-1/4	28	23-3/4	34	25-1/8	34-1/2
112	29	45	33	15-3/4	13-3/8	14-5/8	30	8-1/4	28	23-3/4	34	25-1/8	34-1/2
115	37-1/4	51	43	18-3/4	16	16-1/8	30	14-1/4	43	39-3/4	40	40-1/4	40-1/2
118	37-1/4	51	43	22	19	14-1/2	30	14-1/4	43	39-3/4	40	40-1/4	40-1/2
120	54	60	52	24-7/8	24-7/8	17-9/16	48	14-1/4	52	48-3/4	49	49-1/8	49-1/2
122	54	60	52	27-3/8	27-3/8	16-5/16	48	14-1/4	52	48-3/4	49	49-1/8	49-1/2
125	66	72	60	31-3/8	31-3/8	20-5/16	60	20-1/4	52	48-3/4	61	49-1/8	61-1/2
130	66	72	60	36-7/8	36-7/8	17-9/16	60	20-1/4	52	48-3/4	61	49-1/8	61-1/2

Note: All dimensions in inches subject to manufacturing tolerances.

Figure 7. Horizontal arrangement twin blowers

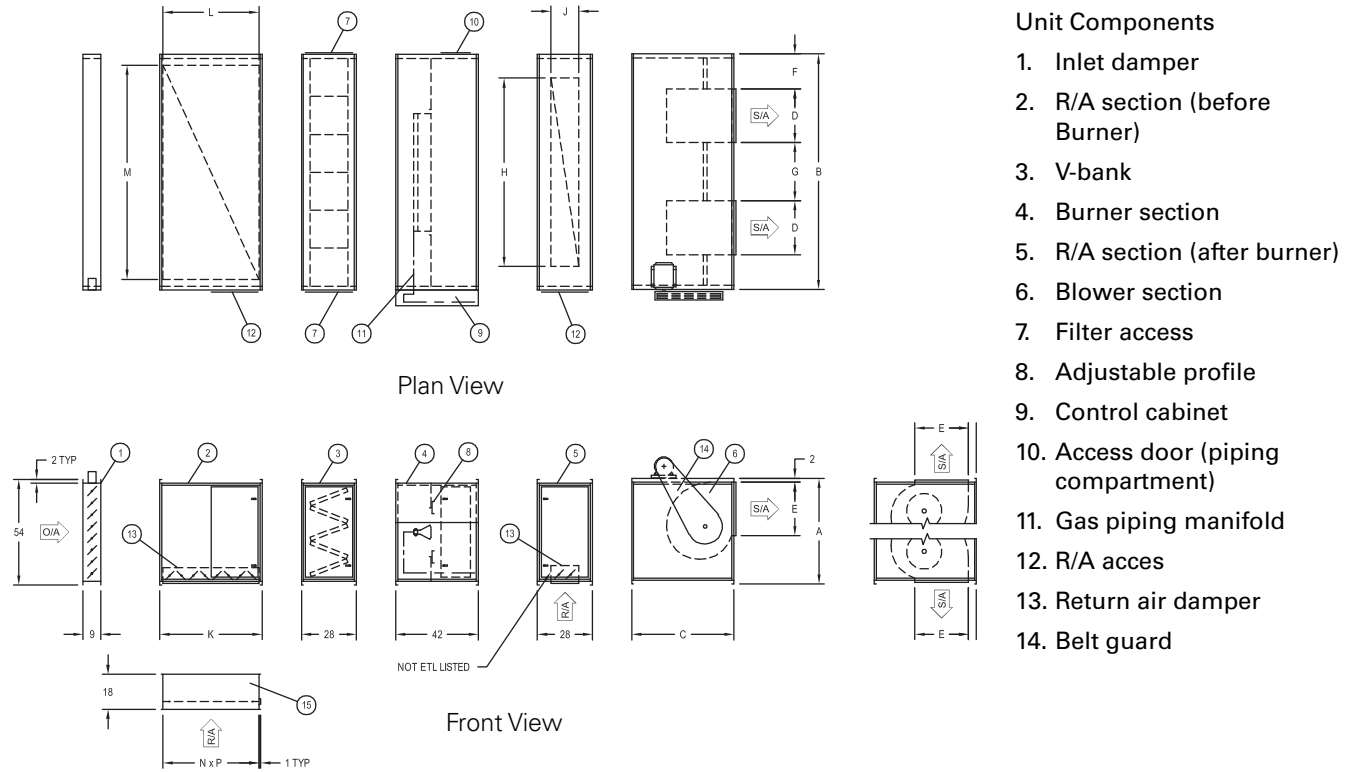
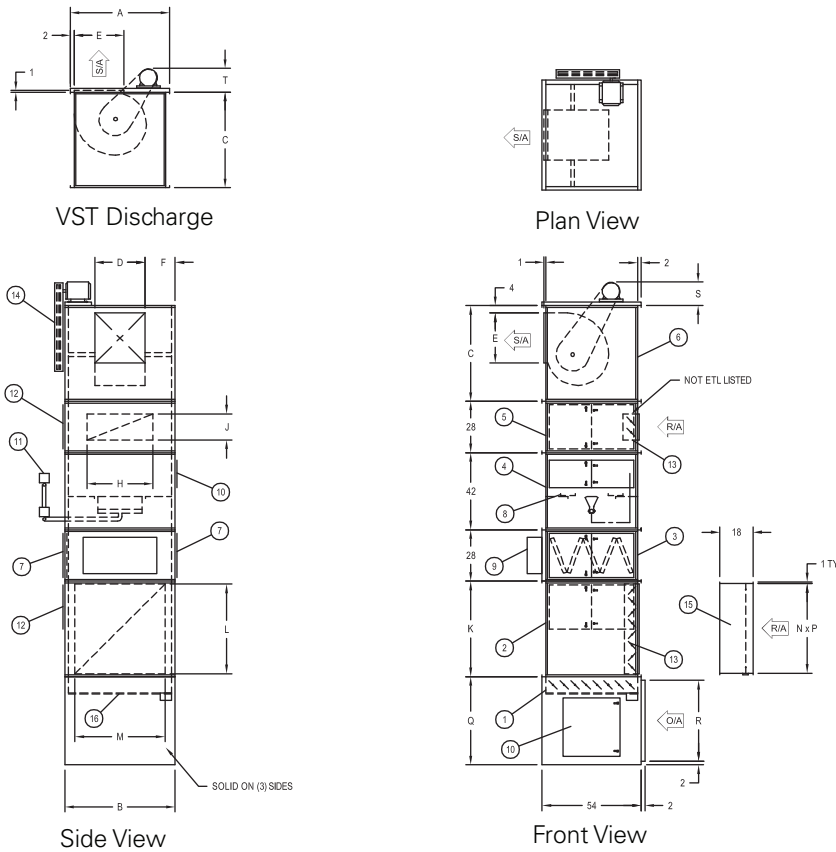

Table 5. Dimensions for horizontal arrangement—Single blower DFIA

Model	A	B	C	D	E	F	G	H	J	K	L	M	N	P
215	37-1/4	93	43	18-3/4	16	16-1/8	22-1/2	79	10	43	39-3/4	82	40-1/4	82-1/2
218	37-1/4	93	43	22	19	13-1/4	22-1/2	79	10	43	39-3/4	82	40-1/4	82-1/2
220	54	120	52	24-7/8	24-7/8	20-1/4	29-5/8	96	14-1/4	52	48-3/4	109	49-1/8	109-1/2
222	54	120	52	27-3/8	27-3/8	14-1/2	29-5/8	96	14-1/4	52	48-3/4	109	49-1/8	109-1/2
225	66	144	60	31-3/8	31-3/8	21-3/4	37-5/8	120	20-1/4	52	48-3/4	133	49-1/8	133-3/8
230	66	144	60	36-7/8	36-7/8	18-5/8	33	120	20-1/4	52	48-3/4	133	49-1/8	133-3/8

Note: All dimensions in inches subject to manufacturing tolerances.

Figure 8. Single blower vertical units

Unit Components

1. Inlet damper
2. R/A section (before burner)
3. V-bank
4. Burner section
5. R/A section (after burner)
6. Blower section
7. Filter access
8. Adjustable profile
9. Control cabinet
10. Access door (piping compartment)
11. Gas piping manifold
12. R/A acces
13. Return air damper
14. Belt guard
15. Screen

Table 6. Dimensions for single blower vertical units—DFIA

Model	A	B	C	D	E	F	H	J	K	L	M	N	PN	Q	R	S
109	29	45	33	12	10-1/2	16-1/8	30	8-1/4	28	23-3/4	34	25-1/8	34-1/2	36	32	17-1/4
112	29	45	33	15-3/4	13-3/8	14-5/8	30	8-1/4	28	23-3/4	34	25-1/8	34-1/2	36	32	17-1/4
115	37-1/4	51	43	18-3/4	16	16-1/8	29-5/8	14-1/4	43	39-3/4	40	40/4	40-1/2	36	32	17-1/4
118	37-1/4	51	43	22	19	14-1/2	30	14-1/4	43	39-3/4	40	40-1/4	40-1/2	36	32	20
120	54	60	52	24-7/8	24-7/8	17-9/16	48	14-1/4	52	48-3/4	49	49-1/8	49-1/2	48	44	20
122	54	60	52	27-3/8	27-3/4	16-5/16	48	14-1/4	52	48-3/4	49	49-1/8	49-1/2	48	44	20
125	66	72	60	31-3/4	31-3/8	20-5/16	60	20-1/4	52	48-3/4	61	49-1/8	61-1/2	48	44	21
130	66	72	60	36-7/8	36-7/8	17-9/16	60	20-1/4	52	48-3/4	61	49-1/8	61-1/2	48	44	21

Note: All dimensions in inches subject to manufacturing tolerances.

Figure 9. Twin blower models vertical units

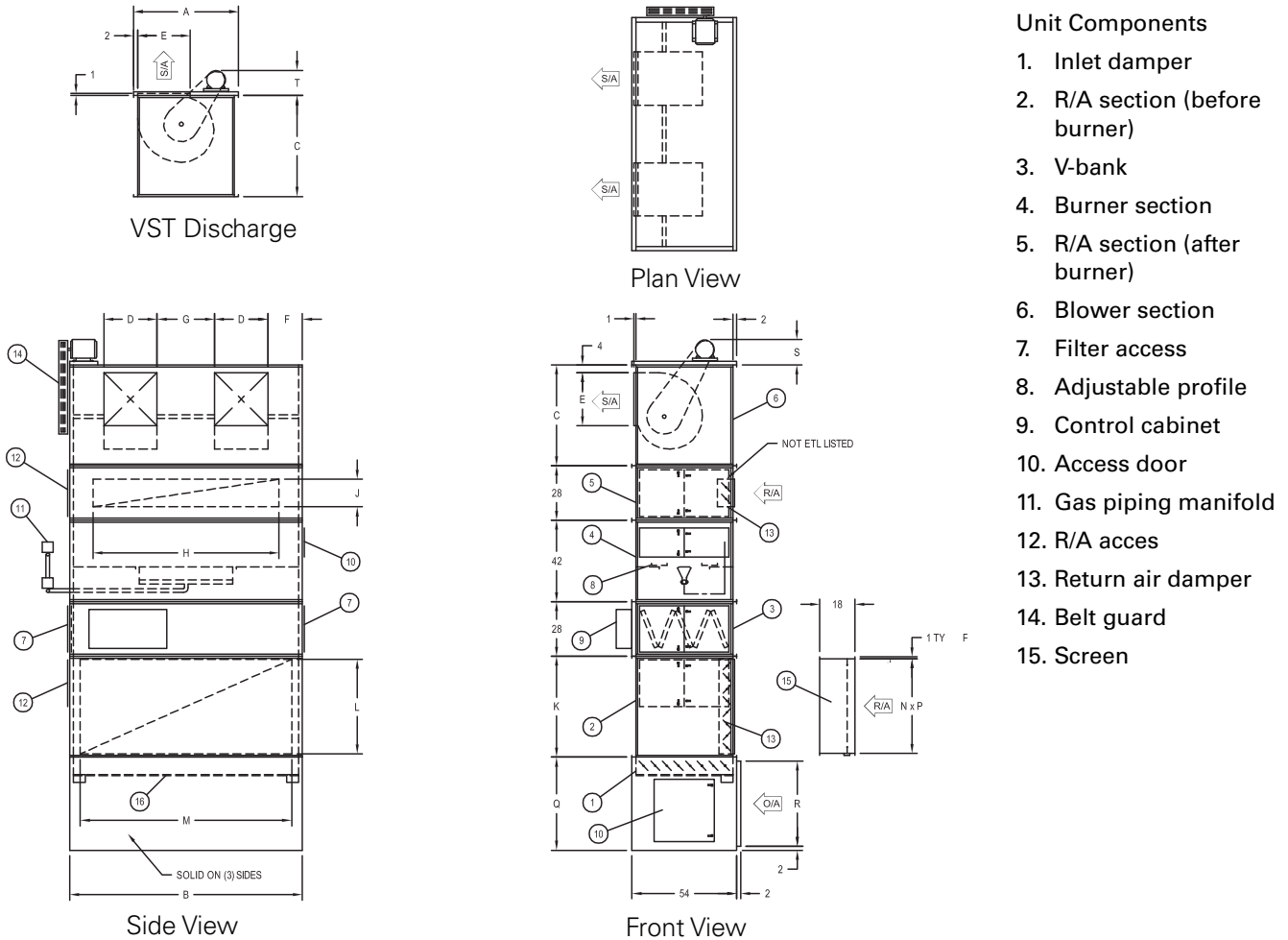
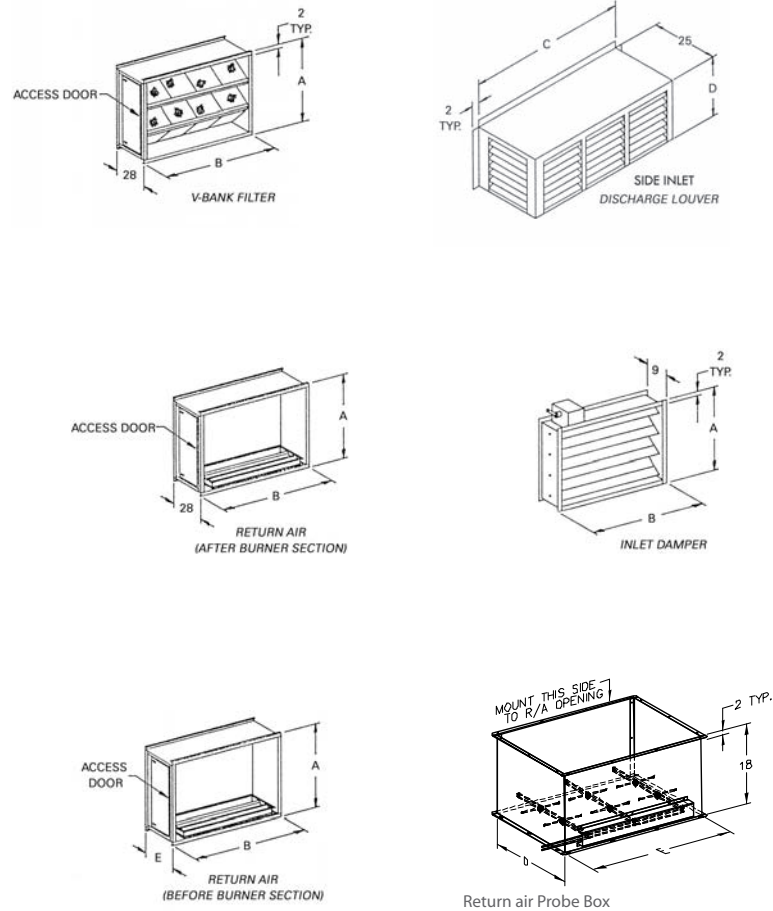

Table 7. Dimensions for twin blower vertical units—DFIA

Model	A	B	C	D	E	F	G	H	J	K	L	M	N	P	Q	R	S
215	37-1/4	93	43	18-3/4	16	16-1/8	22-1/2	79	10	43	39-3/4	82	40-1/4	82-1/2	36	32	18-1/2
218	37-1/4	93	43	22	19	13-1/4	22-1/2	79	10	43	39-3/4	82	40-1/4	82-1/2	36	32	22
220	54	120	52	24-7/8	24-7/8	20-1/4	29-5/8	96	14-1/4	52	48-3/4	109	49-1/8	109-1/2	48	44	22
222	54	120	52	27-3/8	27-3/8	17-3/4	29-5/8	96	14-1/4	52	48-3/4	109	49-1/8	109-1/2	48	44	23-1/2
225	66	144	60	31-3/8	31-3/8	21-3/4	37-5/8	120	20-1/4	52	48-3/4	133	49-1/8	133-1/2	48	44	32-3/4
230	66	144	60	36-7/8	36-7/8	18-5/8	33	120	20-1/4	52	48-3/4	133	49-1/8	133-1/2	48	44	32-3/4

Note: All dimensions in inches subject to manufacturing tolerances.

Figure 10. DFIA Accessories dimensional data

Table 8. DFIA Accesories dimensional data

Model	A	B	C	D	E
109-112	2 ft 5 in	3 ft 9 in	1 ft 5-3/8 in	1 ft 2-3/8 in	2 ft 4 in
115-118	3 ft 1-1/4 in	4 ft 3 in	1 ft 11 in	1 ft 8-3/8 in	3 ft 7 in
120-122	4 ft 6 in	5 ft 0 in	2 ft 4-1/2 in	3 ft 3-1/4 in	4 ft 4 in
125-130	5 ft 6 in	6 ft 0 in	3 ft 4-1/8 in	3 ft 3-1/4 in	4 ft 4 in
215-218	3 ft 1-1/4 in	7 ft 9 in	5 ft 7-3/4 in	1 ft 8-3/8 in	3 ft 7 in
220-222	4 ft 6 in	10 ft 0 in	7 ft 1-3/4 in	3 ft 3-1/4 in	4 ft 4 in
225-230	5 ft 6 in	12 ft 0 in	9 ft 1/8 in	3 ft 3-3/4 in	4 ft 4 in

Weights

Figure 11. DFIA approximate weights

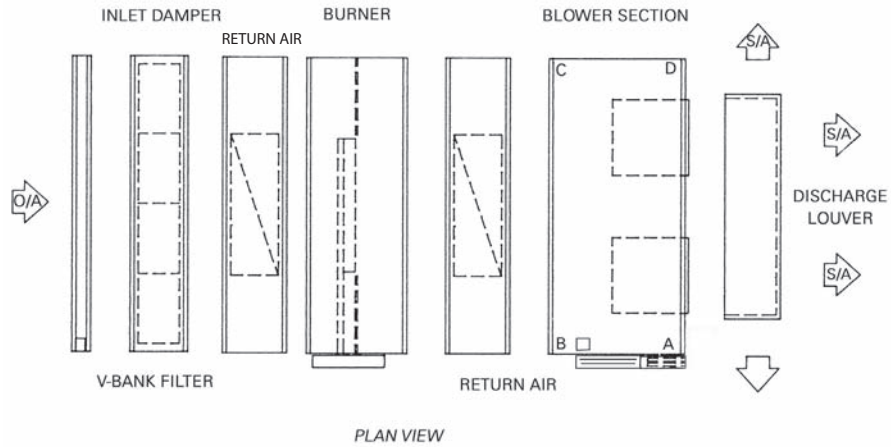

Table 9. DFIA Approximate weights

Unit Size	Blower Section	Vertical Support Stand	Inlet ^(a) Damper	V-Bank ^(a) Filter	Return Air (Before Burner)	Burner Section	Return Air ^(a) (After Burner)	Discharge Louver	A	B	C	D
109	350	180	55	165	104	260	104	70	67	149	67	67
112	350	180	55	165	104	260	104	70	67	149	67	67
115	535	210	70	185	178	375	116	80	94	253	94	94
118	535	210	70	185	178	375	116	80	94	253	94	94
120	916	420	120	275	2809	550	151	110	159	439	159	159
122	916	420	120	275	280	550	151	110	159	439	159	159
125	1262	570	155	310	386	700	208	125	224	590	224	224
130	1262	570	155	310	386	700	208	125	224	590	224	224
215	912	500	125	275	217	510	141	150	158	438	158	158
218	912	500	125	275	217	510	141	150	158	438	158	158
220	1501	625	233	410	420	725	226	215	268	697	268	268
222	1501	625	233	410	420	725	226	215	268	697	268	268
225	2117	845	340	500	560	1010	302	230	388	953	388	388
230	2117	845	340	500	560	1010	302	230	388	953	388	388

(a) When a mixing box option is ordered, these three accessory weights need to be totaled: Inlet Damper, V-Bank Filter, and Return Air (After Burner).

DFOA

Model Number Descriptions

Digit 1, 2, 3 – Unit Type

DFO= Direct-Fired Outdoor Unit

Digit 4 – Development Sequence

A = First Generation

Digit 5, 6, 7 – Unit Size

109	118	220	230
112	215	222	
115	218	225	

Digit 8 – Main Power Supply

A = 115/60/1	D = 208/60/3
B = 230/60/1	E = 230/60/3
C = 208/60/1	F = 460/60/3

Digit 9 – Fuel

N = Natural Gas
P = LP (Propane) Gas

Digit 10 – Design Sequence

H = Eighth Design

Digit 11 – Gas Control Option

E = Modulating Discharge Temp Control
F = Modulating Room Temp Control
G = Modulating Room Temp Control & Pro Room Sensor
H = Modulating Room Temp Control & BACview®

Digit 12 – Gas Train Approvals

0 = No Selection
1 = Standard Gas Train
3 = IRI Gas Train Approval (ETL)
4 = FM Gas Train Approval (ETL)
5 = IRI Gas Train Approval (No ETL)
6 = FM Gas Train Approval (No ETL)

Digit 13 – Burner Input Rating (Natural/Propane)

AA = 275/225 MBh
AB = 550/450 MBh
AC = 825/675 MBh
AE = 1100/1125 MBh
AF = 1375/1350 MBh
AG = 1650/1575 MBh
AH = 1925/1800 MBh
AJ = 2200/2025 MBh
AK = 2475/2475 MBh
AL = 2750/2700 MBh
AN = 3025/2925 MBh
AP = 3300/3150 MBh
AQ = 3575/3375 MBh
AR = 3850/3825 MBh
AT = 4125/4050 MBh
AV = 4400/4275 MBh
AW = 4675/4500 MBh
AX = 4950/4950 MBh
AY = 5225/5175 MBh
AZ = 5500/5400 MBh
A1 = 5775/5624 MBh
A2 = 6050/5850 MBh
A3 = 6325/6075 MBh
A4 = 6600/6525 MBh
A5 = 6875/6750 MBh
A6 = 7150/6975 MBh
A7 = 7425/7425 MBh
A8 = 7700/7650 MBh
A9 = 7975 MBh

Digit 15 – Blower Motor Horsepower

0 = No Selection J = 10 hp
B = 3/4 hp K = 15 hp
C = 1 hp L = 20 hp
D = 1-1/2 hp M = 25 hp
E = 2 hp P = 30 hp
F = 3 hp Q = 40 hp
G = 5 hp R = 50 hp
H = 7-1/2 hp T = 60 hp

Digit 16 – Motor Speed and Starter

0 = No Selection
1 = Single Speed odp 1800 rpm
2 = Single Speed tefc 1800 rpm
3 = Single Speed Ener. Effic odp
4 = Single Speed Ener. Effic tefc
5 = 2s1w odp 1800/900 rpm
6 = 2s2w odp 1800/1200 rpm

Digit 17 – Fan Arrangement

2 = Horizontal Arrangement 2, Front
3 = Horizontal Arrangement 3, Bottom
4 = Vertical Arrangement 4, Side
6 = Vertical Arrangement 6, Side

Digit 18 – Inlet Hood and Birdscreen

O = No Inlet Hood and Birdscreen
A = Inlet Hood/Birdscreen with Permanent Filters
B = Inlet Hood/Birdscreen without Permanent Filters

Digit 19 – V-Bank Filter Section

0 = No V-Bank Filter Section
A = V-Bank Section with Permanent Filters
B = V-Bank Section without Permanent Filters
C = V-Bank Section with TA Filters
D = V-Bank Section with Pleated Filters

Digit 20 – Damper/Mixing Box

0 = No Damper/Mixing Box Selected (No ETL)
A = Motorized 75/25 Damper (Manual Control)
B = Motorized Damper 75/25 (Bldg Press Control)
C = Mixing Box - Temperature Control (No ETL)
D = Mixing Box - Building Press Control (No ETL)
E = Mixing Box - Manual Control (No ETL)
F = Mixing Box with Airflow Station - Manual Control (ETL)
G = Mixing Box with Airflow Station - Temp Control (ETL)
H = Mixing Box with Airflow Station - Bldg Press Control (ETL)

Digit 21 – Controls Opposite from Standard

0 = Standard Controls
A = Controls Opposite from Standard

Digit 22 – Motorized Inlet Damper

0 = No Motorized Inlet Damper
B = Motorized Inlet Damper

Digit 23 – Motorized Outlet Damper

0 = No Motorized Outlet Damper
C = Motorized Outlet Damper

Digit 24 – Insulation

D = Insulation on Entire Unit

Digit 25 – Internal Blower/Motor Isolation

F = Internal Blower/Motor Isolation

Digit 26 – Extended Grease Lines

G = Extended Grease Lines

Digit 27 – 115V Duplex Service Receptacle

K=115 Volt Duplex Service Receptacle



DFOA

Digit 28 — Painted Basic Unit and Accessories

M = Painted Basic Unit and Accessories

Digit 29 — UV Flame Sensor

N = UV Flame Sensor

Digit 30 — Clogged Filter Indicator

P = Clogged Filter Indicator

Digit 31 — Exhaust Interlock

Q = Exhaust Interlock

Digit 32 — Interlocking Relay

R = Interlocking Relay

Digit 33 — Omit Disconnect Switch

DS = Disconnect Switch

V = Omit Disconnect Switch

Digit 34 — High Gas Pressure Regulator

7 = High Gas Press Reg 0.5–1 psi

W = High Gas Press Reg 1–5 psi

X = High Gas Press Reg 5–10 psi

6 = High Gas Press Reg Over 10 psi

Digit 35 — Adjustable Drive

Y = Adjustable Drive

Digit 36 — Low Gas Pressure Burner

8 = Low Gas Pressure Burner

Digit 37 — Vibration Options

Z = Vibration Feet—Full Unit

Digit 38 — Control Options

2 = 7-Day Time Clock

5 = On/Off Night Setback Thermostat

7 = BACview® Remote Panel

Digit 39 — Discharge Louver

M = Discharge Louver

Digit 40 — Separator for Unit Model Number

= Separator for AOS Model Number

Digit 41 — Roofcurbs

A = Curb for Basic Frame, No Return Air

B = Curb for Basic Frame Return Air Downstream

C = Curb for Basic Frame with Mixing Box

Features and Benefits

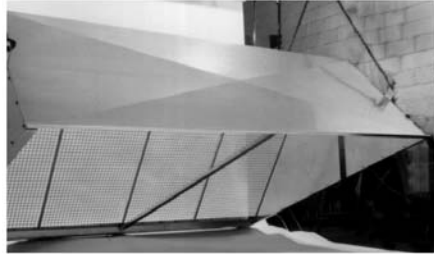

Gas burner section

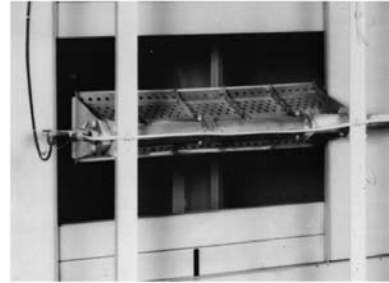

Supply air intake view showing inlet hood and birdscreen

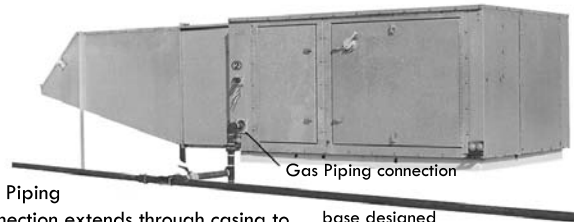

Gas Piping

Connection extends through casing to simplify field installations

Gas Piping connection

base designed for curb mounting



Optional inlet damper with V-bank Filter



Factory assembled gas manifold compartment

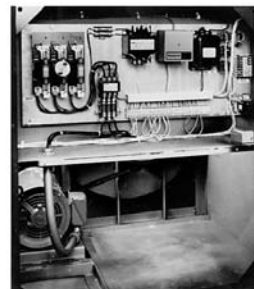

Access compartment to control panel and fan motor
note: fan motor panel removed for photograph

Basic Unit

Feature: Casing with galvanized finish.

Benefit: Rust problem is greatly reduced.

Feature: Watertight construction.

Benefit: Designed for indoor or outdoor mounting.

Feature: Access doors are hinge mounted with industrial type hardware.

Benefit: Provides simple access to service compartments without removing sheet metal screws and panels.

Feature: Adjustable motor mount

Benefit: Belt tension can be field adjusted for maximum belt life and for motor speed adjustment

Feature: Basic unit is factory assembled and wired.

Benefit: Reduces field installation cost.

Feature: All fuses factory furnished.

Benefit: Delay at start-up eliminated.

Feature: Factory tested before being shipped.

Benefit: Eliminates majority of field start-up problems caused by defective controls.

Gas-Fired Unit

Feature: Many units bear the ETL label.

Benefit: Meets certain specification requirements.

Feature: Optional temperature control systems available.

Benefit: Select system to satisfy application.

Feature: Optional dual fuel gas manifold.

Benefit: Standby flexibility in case natural gas supply is interrupted.

Feature: Optional construction provides return air cycle.

Benefit: Maximum 80 percent return air cycle results in fuel economy for pressurized heating systems and eliminates need for two-speed fan operation. Minimizes heating costs.

Performance Data

Table 10. Direct-Fired Outdoor Air (DFOA) unit—General data

Unit Size	109	112	115	118	215	218	220	222	225	230
Airflow										
Min. Airflow (cfm)	1600	3250	4500	6500	9000	12500	18000	25000	30000	44000
Max. Airflow (cfm)	3000	4250	6000	8500	12000	17000	26000	31000	46000	64000
Fan										
Quantity - Wheel Size	1 - 9	1 - 12	1 - 15	1 - 18	2 - 15	2 - 18	2 - 20	2 - 22	2 - 25	2 - 30
Motor (hp)	1-5	1.5-5	2-7.5	3-10	5-15	7.5-20	7.5-25	15-30	15-50	20-60
Filters, 2-in V-Bank Filter										
Quantity	9	9	9	9	18	18	25	25	36	36
Size (in)	20x15	20x15	20x15	20x15	20x15	20x15	20x20	20x20	20x25	20x25
Inlet Hood and Birdscreen										
Quantity	4	4	8	8	16	16	18	18	66	66
Size	20x16	20x16	20x16	20x16	20x16	20x16	20x25	20x25	20x15	20x15

Table 11. Direct-Fired Outdoor Air (DFOA) unit—Performance data

Models DFO	Blower Size (in.)	CFM Std Air at 70	FPM Outlet Velocity	Total External Static Pressure (in. wc)							
				1/4	3/8	1/2	3/4	1	1-1/4	1-1/2	2
				Horsepower							
109	1-9	1600	1915	1	1	1	1	—	—	—	—
		1800	2155	1	1	1-1/2	1-1/2	1-1/2	1-1/2	—	—
		2000	2390	1-1/2	1-1/2	1-1/2	1-1/2	1-1/2	2	2	—
		2250	2690	1-1/2	1-1/2	1-1/2	2	2	2	2	3
		2500	2990	2	2	2	2	2	3	3	3
		2750	3290	2	2	2	3	3	3	3	3
		3000	3585	3	3	3	3	3	3	3	5
112	1-12	3250	2180	1-1/2	2	2	2	3	3	3	3
		3500	2360	2	2	2	3	3	3	3	5
		3750	2540	2	2	3	3	3	3	3	5
		4000	2720	3	3	3	3	3	3	5	5
		4250	2900	3	3	3	3	3	3	5	5
115	1-15	4500	2190	2	2	3	3	3	3	5	—
		5000	2430	3	3	3	3	3	5	5	5
		5500	2670	3	3	3	5	5	5	5	5
		6000	2910	3	5	5	5	5	5	5	7-1/2

Note: External Pressure Drop in inches of water. Add pressure drop of the optional accessories, if used, to the pressure drop of the duct work:

1. Fresh Air Inlet Hood and Birdscreen: 13 in. wc
2. Fresh Air Inlet Hood with Filters: 25 in. wc
3. Motor Operated Inlet Damper: 13 in. wc
4. Motor Operated Discharge Damper: 50 in. wc
5. V-Bank Filter Section: 25 in. wc
6. Mixing Box: 40 in. wc
7. Discharge Louver: 13 in. wc



DFOA

Table 11. Direct-Fired Outdoor Air (DFOA) unit—Performance data (continued)

Models DFO	Blower Size (in.)	CFM Std Air at 70	FPM Outlet Velocity	Total External Static Pressure (in. wc)							
				1/4	3/8	1/2	3/4	1	1-1/4	1-1/2	2
118	1-18	6500	2215	3	5	5	5	5	5	5	7-1/2
		7000	2390	5	5	5	5	5	5	7-1/2	7-1/2
		7500	2565	5	5	5	5	5	7-1/2	7-1/2	7-1/2
		8000	2740	5	5	5	7-1/2	7-1/2	7-1/2	7-1/2	7-1/2
		8500	2915	5	5	7-1/2	7-1/2	7-1/2	7-1/2	7-1/2	10
215	2-15	9000	2190	5	5	5	5	5	—	—	—
		9500	2310	5	5	5	5	7-1/2	7-1/2	—	—
		10000	2430	5	5	5	7-1/2	7-1/2	7-1/2	7-1/2	—
		10500	2550	5	5	7-1/2	7-1/2	7-1/2	7-1/2	7-1/2	—
		11000	2670	7-1/2	7-1/2	7-1/2	7-1/2	7-1/2	7-1/2	10	10
		11500	2790	7-1/2	7-1/2	7-1/2	7-1/2	7-1/2	10	10	10
218	2-18	12000	2910	7-1/2	7-1/2	7-1/2	7-1/2	10	10	10	15
		12500	2125	7-1/2	7-1/2	7-1/2	7-1/2	7-1/2	—	—	—
		13000	2215	7-1/2	7-1/2	7-1/2	7-1/2	10	10	—	—
		14000	2390	7-1/2	7-1/2	7-1/2	10	10	10	15	—
		15000	2565	7-1/2	10	10	10	10	15	15	15
		16000	2740	10	10	10	10	15	15	15	15
		17000	2915	10	10	10	15	15	15	15	20
220	2-20	18000	2140	7-1/2	10	10	10	15	15	15	—
		19000	2260	10	10	10	10	15	15	15	—
		20000	2380	10	10	10	15	15	15	15	20
		21000	2500	10	15	15	15	15	20	20	20
		22000	2620	15	15	15	15	15	15	20	20
		23000	2740	15	15	15	15	15	20	20	20
		24000	2860	15	15	15	15	20	20	20	25
		25000	2980	15	15	15	20	20	20	20	25
		26000	3100	15	20	20	20	20	20	25	25
222	2-22	25000	2450	15	15	15	15	20	20	20	25
		26000	2550	15	15	15	20	20	20	20	25
		27000	2650	15	15	15	20	20	20	25	25
		28000	2750	15	20	20	20	20	25	25	30
		29000	2850	20	20	20	20	25	25	25	30
		30000	2950	20	20	20	20	25	25	25	30
		31000	3050	20	20	20	25	25	25	30	30

Note: External Pressure Drop in inches of water. Add pressure drop of the optional accessories, if used, to the pressure drop of the duct work:

1. Fresh Air Inlet Hood and Birdscreen: 13 in. wc
2. Fresh Air Inlet Hood with Filters: 25 in. wc
3. Motor Operated Inlet Damper: 13 in. wc
4. Motor Operated Discharge Damper: 50 in. wc
5. V-Bank Filter Section: 25 in. wc
6. Mixing Box: 40 in. wc
7. Discharge Louver: 13 in. wc

Table 11. Direct-Fired Outdoor Air (DFOA) unit—Performance data (continued)

Models DFO	Blower Size (in.)	CFM Std Air at 70	FPM Outlet Velocity	Total External Static Pressure (in. wc)							
				1/4	3/8	1/2	3/4	1	1-1/4	1-1/2	2
225	2–25	30000	2235	15	15	15	15	20	20	—	—
		32000	2385	15	15	15	20	20	20	25	—
		34000	2535	15	20	20	20	20	25	25	30
		36000	2685	20	20	20	20	25	25	30	30
		38000	2835	20	20	20	25	25	30	30	40
		40000	2985	20	25	25	25	30	30	30	40
		42000	3135	25	25	25	30	30	40	40	40
		44000	3285	25	30	30	30	40	40	40	40
		46000	3430	30	30	30	40	40	40	40	50
230	2–30	44000	2365	20	20	20	25	25	30	—	—
		48000	2580	20	25	25	25	30	30	40	—
		52000	2800	25	25	30	30	40	40	40	50
		56000	3020	30	30	30	40	40	40	40	50
		60000	3240	40	40	40	40	40	50	50	50
		64000	3440	40	40	40	50	50	50	50	60

Note: External Pressure Drop in inches of water. Add pressure drop of the optional accessories, if used, to the pressure drop of the duct work:

1. Fresh Air Inlet Hood and Birdscreen: 13 in. wc
2. Fresh Air Inlet Hood with Filters: 25 in. wc
3. Motor Operated Inlet Damper: 13 in. wc
4. Motor Operated Discharge Damper: 50 in. wc
5. V-Bank Filter Section: 25 in. wc
6. Mixing Box: 40 in. wc
7. Discharge Louver: 13 in. wc

Table 12. Direct-Fired Outdoor Air (DFOA) unit—Burner selection table (MBh)

DFOA Model	CFM Std. Air							
	70°	70° Rise	80° Rise	90° Rise	100° Rise	110° Rise	120° Rise	130° Rise
109	1600	142	159	175	191	206	221	235
	1800	160	179	179	215	232	248	264
	2000	177	199	219	239	258	276	294
	2250	200	224	247	269	290	311	330
	2500	222	248	274	299	322	345	367
	2750	244	273	201	328	354	380	404
	3000	266	298	329	358	387	414	440
112	3250	288	323	356	388	419	449	477
	3500	311	348	384	418	451	483	514
	3750	333	373	411	448	483	518	550
	4000	355	397	438	478	516	552	587
	4250	377	422	466	508	548	587	624
115	4500	399	447	493	537	580	621	661
	5000	444	497	548	597	644	690	734
	5500	488	546	603	657	709	759	807
	6000	533	596	658	717	773	828	881



DFOA

Table 12. Direct-Fired Outdoor Air (DFOA) unit—Burner selection table (MBh) (continued)

DFOA Model	CFM Std. Air							
	70°	70° Rise	80° Rise	90° Rise	100° Rise	110° Rise	120° Rise	130° Rise
118	6500	577	646	712	776	838	897	954
	7000	621	697	767	836	902	966	1027
	7500	665	745	822	896	967	1035	1101
	8000	710	795	877	955	1031	1104	1174
	8500	754	845	932	1015	1096	1173	1248
215	9000	798	894	986	1057	1160	1242	1321
	9500	843	944	1041	1135	1224	1311	1394
	10000	887	994	1096	1194	1289	1380	1468
	10500	932	1043	1151	1254	1353	1449	1541
	11000	976	1039	1205	1314	1418	1518	1615
	11500	1020	1143	1260	1373	1482	1587	1688
218	12000	1065	1192	1315	1433	1547	1656	1761
	12500	1109	1242	1370	1493	1611	1725	1835
	13000	1153	1292	1452	1553	1676	1794	1908
	14000	1242	1391	1534	1672	1804	1932	2055
	15000	1331	1490	1644	1791	1933	2070	2202
	16000	1419	1590	1753	1911	2062	2208	2349
220	17000	1508	1689	1863	2030	2191	2346	2495
	18000	1597	1788	1973	2105	2320	2484	2642
	19000	1686	1888	2082	2269	2449	2622	2789
	20000	1774	1987	2192	2388	2578	2760	2936
	21000	1863	2087	2301	2508	2707	2898	3082
	22000	1952	2186	2411	2627	2836	3036	3229
	23000	2040	2285	2521	2747	2964	3174	3376
	24000	2129	2385	2630	2866	3093	3312	3523
222	25000	2218	2484	2740	2986	3222	3450	3670
	26000	2307	2583	2849	3105	3351	3588	3816
	27000	2395	2683	2959	3224	3480	3726	3963
	28000	2484	2782	3069	3344	3609	3864	4110
	29000	2573	2881	3178	3463	3738	4002	4257
	30000	2661	2981	3288	3583	3867	4140	4404
	31000	2750	3080	3397	3702	3996	4278	4550
225	30000	2661	2981	3288	3583	3867	4140	4404
	32000	2839	3180	3507	3822	4124	4416	4697
	34000	3016	3378	3726	4060	4382	4692	4991
	36000	3194	3577	3945	4299	4640	4968	5284
	38000	3371	3776	4164	4538	4898	5544	5578
	40000	3549	3974	4384	4777	5156	5520	5871
	42000	3762	4173	4603	5016	5413	5796	6165
	44000	3903	4372	4822	5255	5671	6072	6458
46000	3780	4320q	4860	5400	5940	6480	7046	

Table 12. Direct-Fired Outdoor Air (DFOA) unit—Burner selection table (MBh) (continued)

DFOA Model	CFM Std. Air							
	70°	70° Rise	80° Rise	90° Rise	100° Rise	110° Rise	120° Rise	130° Rise
230	44000	3903	4372	4822	5255	5671	6072	6458
	48000	4258	4769	5260	5732	6187	6624	7046
	52000	4273	4883	5494	6104	6715	7325	8807
	56000	4968	5564	6317	6688	7218	7728	8220
	60000	5323	5962	6575	7165	7733	8280	8807
	64000	5678	6359	7014	7643	8249	8832	9394

Dimensions

Figure 12. Single blower sizes 109–130

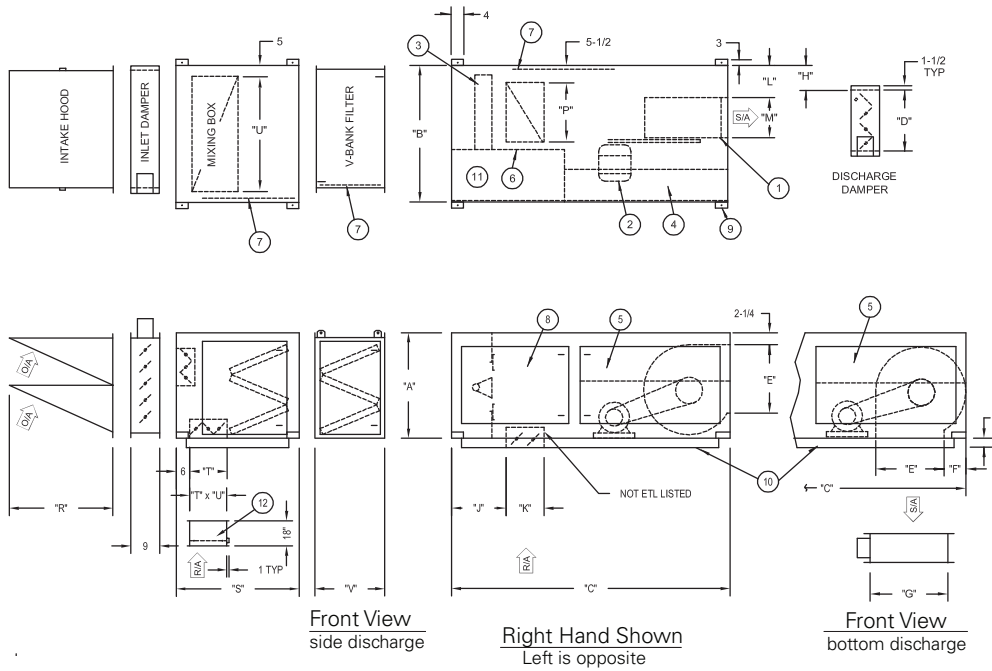

Unit Components

1. Centrifugal supply fan
2. Fan motor
3. Line burner
4. Control cabinet
5. Hinged control cabinet access door
6. Observation port
7. Access door
8. Access door (piping compartment)
9. Lifting lug
10. Unit base
11. Manifold compartment

Table 13. Dimensions for DFOA single blower sizes 109–130

Model	A	B	C	D	E	F	G	H	J
109	36	52	77	17-13/16	10-3/8	15-1/8	14-7/16	11-9/16	19
112	36	52	77	17-13/16	13-9/16	13-9/16	14-7/16	11-9/16	19
115	36	52	77	23-15/16	16	12-3/8	19-7/8	8-5/8	19
118	36	52	77	23-15/16	19	12-3/8	19-7/8	6-15/16	19
120	48	78	96	29-1/2	24-7/8	13-3/16	28-1/4	10-5/32	19
122	48	78	96	29-1/2	27-3/8	13-3/16	28-1/4	11-13/32	19
125	60	91	96	38-7/8	31-3/8	17-9/16	37-3/4	11-13/16	12-5/16
130	60	91	96	38-7/8	36-7/8	17-9/16	37-3/4	14-7/16	12-5/16

Model	K	L	M	P	R	S	T	U	V
109	14-1/4	14-1/2	11-15/16	27-3/4	32	54	20-1/4	42	22
112	14-1/4	12-1/2	15-15/16	27-3/4	32	54	20-1/4	42	22
115	14-1/4	11-1/8	18-15/16	27-3/4	32	54	20-1/4	42	22
118	14-1/4	7-7/8	22-1/16	27-3/4	32	54	20-1/4	42	22
120	14-1/4	12-1/8	25-1/16	48	38-1/2	60	20-1/4	68	22
122	14-1/4	12-3/8	27-9/16	48	38-1/2	60	20-1/4	68	22
125	20-1/4	15-1/8	31-1/2	49	53	65	26-1/2	81	28
130	20-1/4	15-3/8	37	49	53	65	26-1/2	81	28

Note: All dimensions in inches subject to manufacturing tolerances.

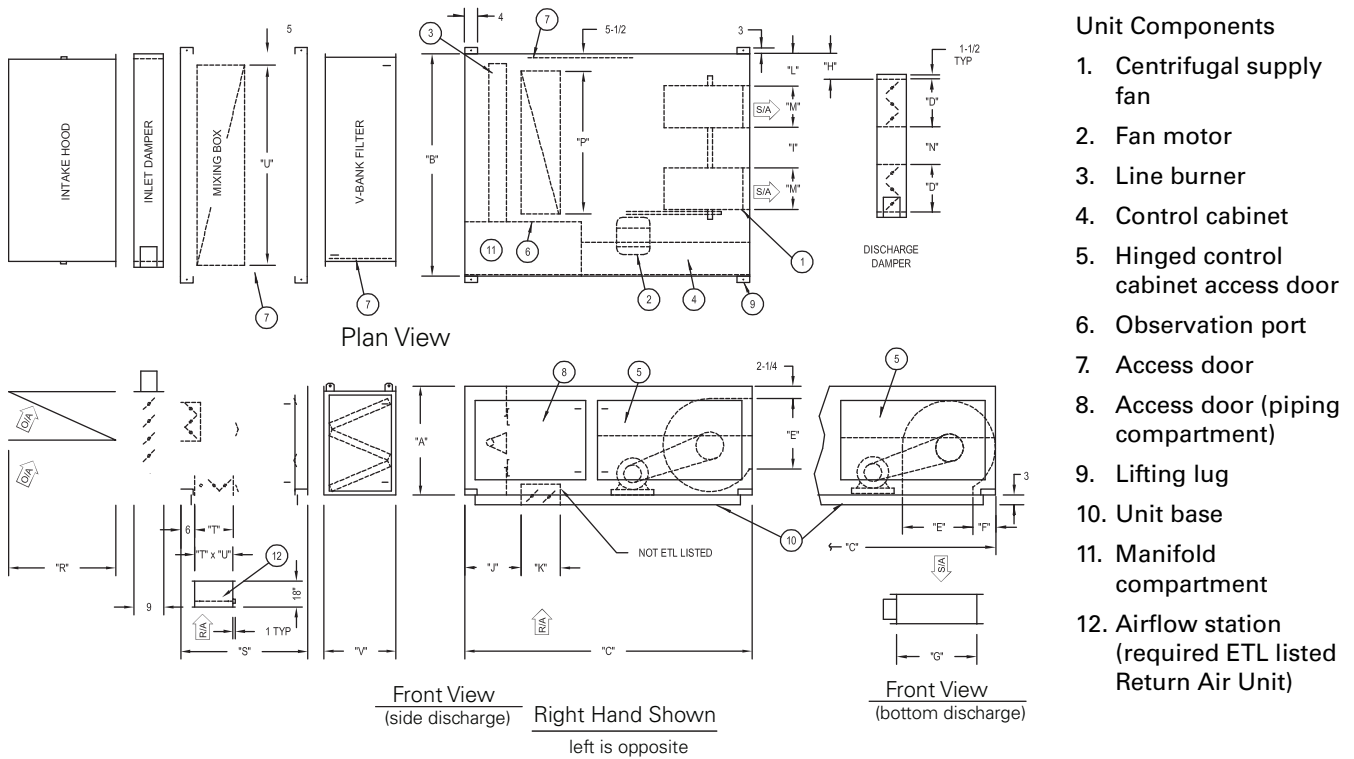
Figure 13. Twin blower sizes 215–230

Unit Components

1. Centrifugal supply fan
2. Fan motor
3. Line burner
4. Control cabinet
5. Hinged control cabinet access door
6. Observation port
7. Access door
8. Access door (piping compartment)
9. Lifting lug
10. Unit base
11. Manifold compartment
12. Airflow station (required ETL listed Return Air Unit)

Table 14. Dimensions for DFOA twin blower sizes 215–230

Model	A	B	C	D	E	F	G	H	I	J
215	36	94	77	23-15/16	16	12-3/8	19-7/8	6-15/16	22-1/4	19
218	36	94	77	23-15/16	19	12-3/8	19-7/8	6-15/16	16	19
220	48	130	96	29-7/16	24-7/8	13-3/16	28-1/4	11-7/16	29-5/8	19
222	48	130	96	29-7/16	27-3/8	13-3/16	28-1/4	11-7/16	24-5/8	19
225	60	154	96	38-7/8	31-3/8	17-9/16	37-3/4	14-7/16	37-5/8	12-5/16
230	60	154	96	38-7/8	36-7/8	17-9/16	37-3/4	14-7/16	26-5/8	12-5/16

Model	K	L	M	N	P	R	S	T	U	V
215	14-1/4	7-7/8	18-15/16	14	65-3/4	32	54	20-1/4	84	22
218	14-1/4	7-7/8	22-1/16	14	65-3/4	32	54	20-1/4	84	22
220	14-1/4	12-3/8	25-1/16	22-5/8	87-3/8	44-1/2	60	20-1/4	120	22
222	14-1/4	12-3/8	27-9/16	22-5/8	87-3/8	44-1/2	60	20-1/4	120	22
225	20-1/4	15-3/8	31-1/2	24-5/8	111-3/8	56-1/2	65	26-1/2	144	28
230	20-1/4	15-3/8	37	24-5/8	111-3/8	56-1/2	65	26-1/2	144	28

Note: All dimensions in inches subject to manufacturing tolerances.

Figure 14. Twin blower sizes 233 and 240

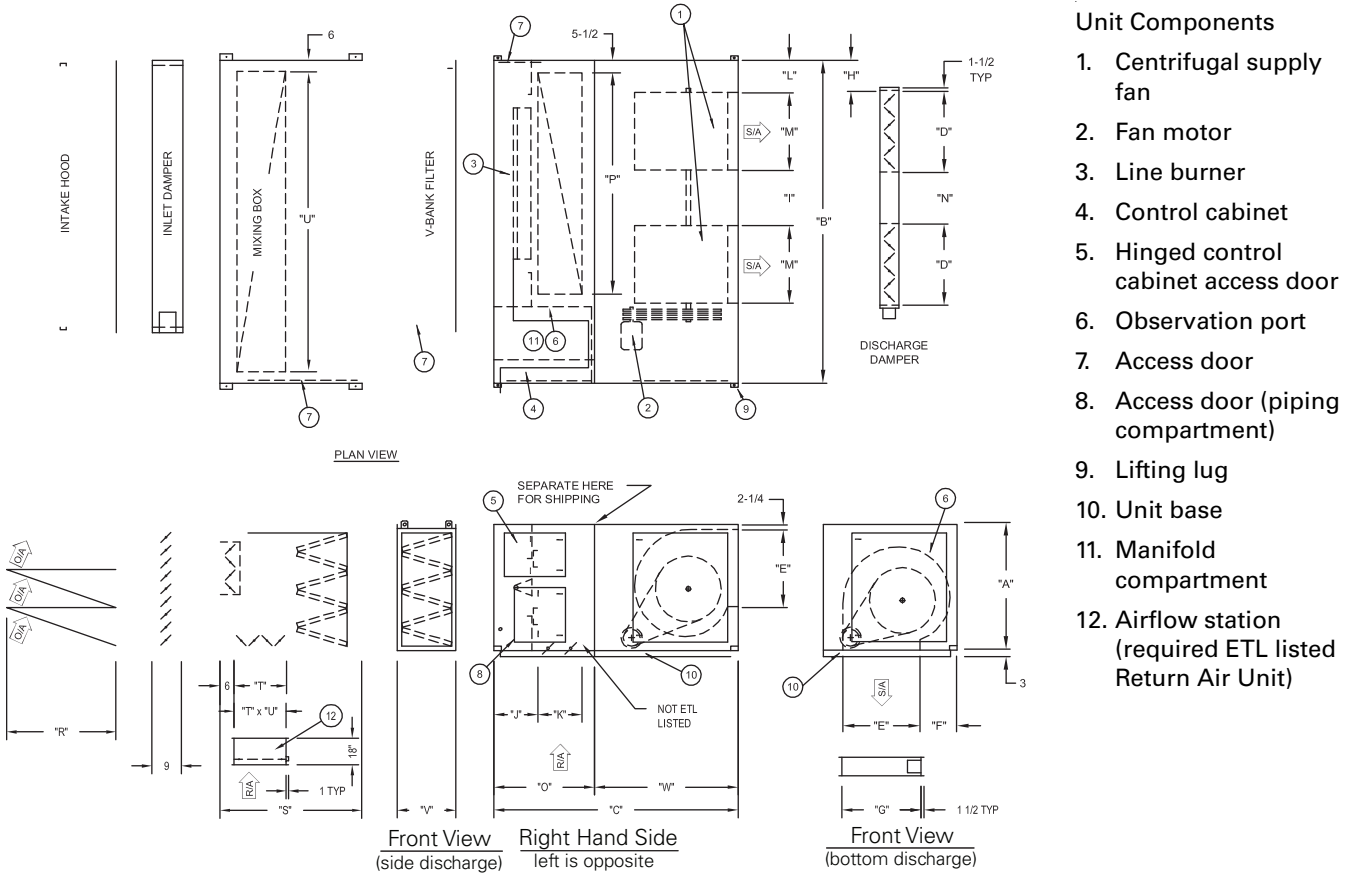

Unit Components

1. Centrifugal supply fan
2. Fan motor
3. Line burner
4. Control cabinet
5. Hinged control cabinet access door
6. Observation port
7. Access door
8. Access door (piping compartment)
9. Lifting lug
10. Unit base
11. Manifold compartment
12. Airflow station (required ETL listed Return Air Unit)

Table 15. Dimensions for DFOA twin blower sizes 233 and 240

Model	A	B	C	D	E	F	G	H	I	J	K
233	68	175	117	43-3/4	43-1/16	19-7/16	44	16-1/16	36	20	20-1/4
240	79-1/4	210	131	55-3/4	41	33	42	19-1/16	39-7/8	20	20-1/4

Model	L	M	N	O	PS	R	S	T	U	V	W
233	17	39-7/8	34-1/8	45	130	56-1/2	70	31-1/4	163	28	72
240	20	53-7/8	38	45	166	51-1/2	70	31-1/4	198	28	86

Note: All dimensions in inches subject to manufacturing tolerances.

Figure 15. Vertical models sizes 109–130

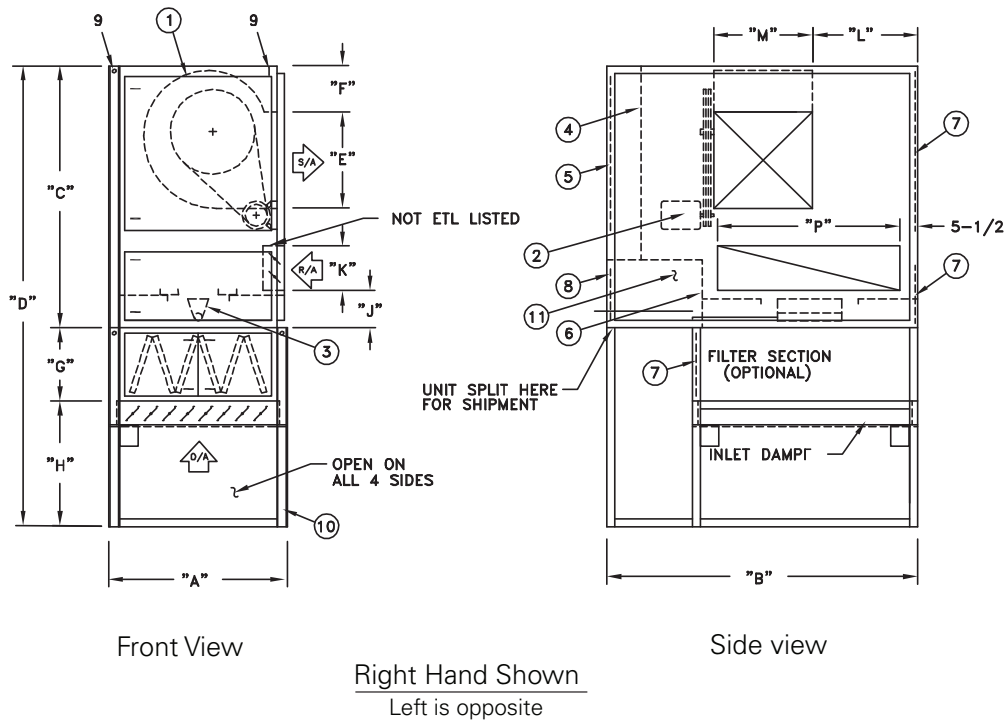

Unit Components

1. Centrifugal supply fan
2. Fan motor
3. Line burner
4. Control cabinet
5. Hinged control cabinet access door
6. Observation port
7. Access door
8. Access door (piping compartment)
9. Lifting lug
10. Unit support stand
11. Manifold compartment

Table 16. Dimensions vertical models sizes 109–130

Model	A	B	C	D	E	F	G	H	J	K	L	M
109	42	52	77	135	10-3/8	15-1/8	22	36	14-1/2	11-15/16	20-1/4	42
112	42	52	77	135	13-9/16	13-9/16	22	36	12-1/2	15-15/16	20-1/4	42
115	42	52	77	135	16	12-3/8	22	36	11-1/8	18-15/16	20-1/4	42
118	42	52	77	135	19	12-3/8	22	36	7-7/8	22-1/16	20-1/4	42
120	56	78	96	166	24-7/8	13-3/16	22	48	12-3/8	25-1/16	20-1/4	68
122	56	78	96	166	27-3/8	13-3/16	22	48	12-3/8	27-9/16	20-1/4	68
125	68	91	96	172	31-3/8	17-9/16	28	48	15-3/8	31-1/2	26-1/2	81
130	68	91	96	172	36-7/8	17-9/16	28	48	15-3/8	37	26-1/2	81

Note: All dimensions in inches subject to manufacturing tolerances.

Figure 16. Vertical models sizes 109–130 with mixing box

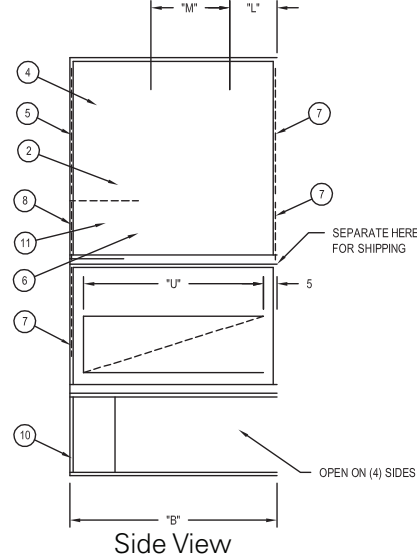
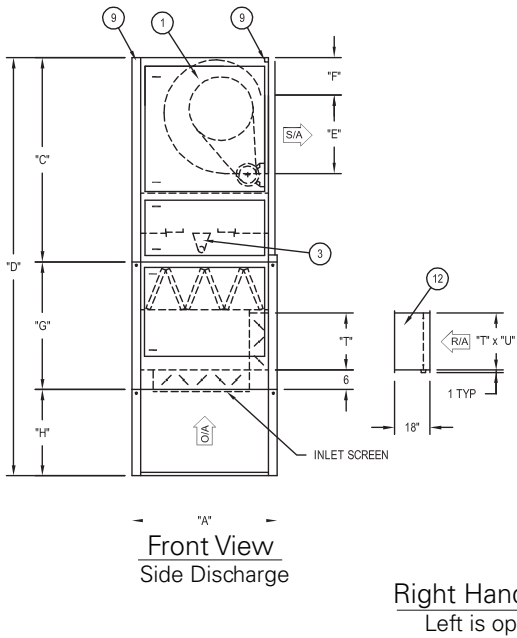

Unit Components

1. Centrifugal supply fan
2. Fan motor
3. Line burner
4. Control cabinet
5. Hinged control cabinet access door
6. Observation port
7. Access door
8. Access door (piping compartment)
9. Lifting lug
10. Unit support stand
11. Manifold compartment
12. Airflow station (required ETL listed return air unit)

Table 17. Dimensions for vertical models sizes 109–130 with mixing box

Model	A	B	C	D	E	F	G	H	L	M	T	U
109	42	52	77	167	10 3/8	15 1/8	54	36	14 1/2	11 15/16	20 1/4	42
112	42	52	77	167	13 9/16	13 9/16	54	36	12 1/2	15 15/16	20 1/4	42
115	42	52	77	167	16	12 3/8	54	36	11 1/8	18 15/16	20 1/4	42
118	42	52	77	167	19	12 3/8	54	36	7 7/8	22 1/16	20 1/4	42
120	56	78	96	204	24 7/8	13 3/16	60	48	12 3/8	25 1/16	20 1/4	68
122	56	78	96	204	27 3/8	13 3/16	60	48	12 3/8	27 9/16	20 1/4	68
125	68	91	96	209	31 3/8	17 9/16	65	48	15 3/8	31 1/2	26 1/2	81
130	68	91	96	209	36 7/8	17 9/16	65	48	15 3/8	37	26 1/2	81

Note: All dimensions in inches subject to manufacturing tolerances.

Figure 17. Vertical models sizes 215–230

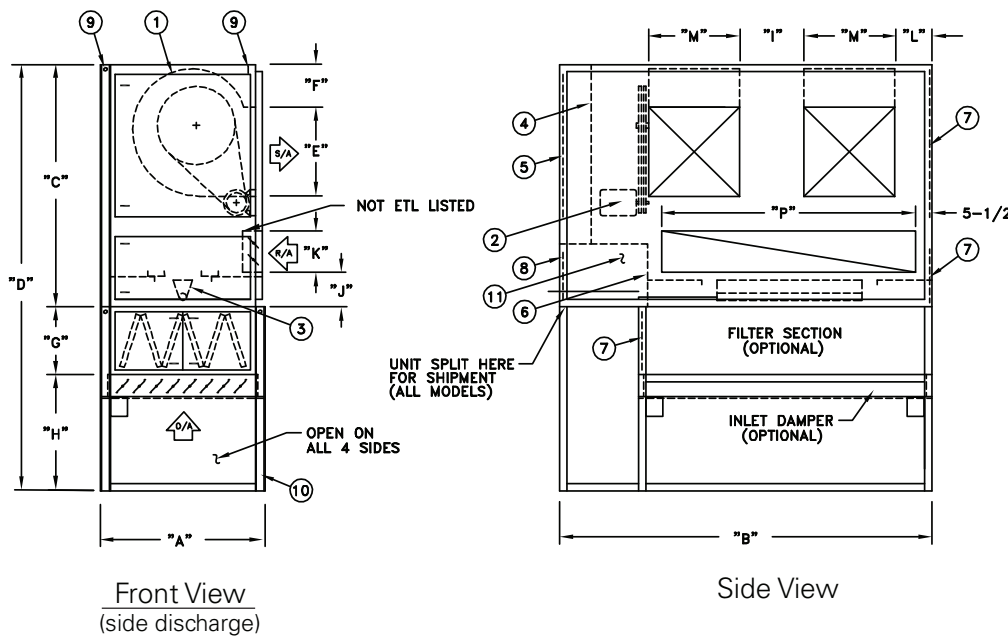

- Unit Components
1. Centrifugal supply fan
 2. Fan motor
 3. Line burner
 4. Control cabinet
 5. Hinged control cabinet access door
 6. Observation port
 7. Access door
 8. Access door (piping compartment)
 9. Lifting lug
 10. Unit support stand
 11. Manifold compartment
 12. Airflow station (required ETL listed return air unit)

Right Hand Shown
left is opposite

Table 18. Dimensions for vertical models sizes 215-230

Model	A	B	C	D	E	F	G	H	I	J	K	L	M	P
215	42	94	77	135	16	12-3/8	22	36	22-1/4	19	14-1/4	7-7/8	18-15/16	65-3/4
218	42	94	77	135	19	12-3/8	22	36	16	19	14-1/4	7-7/8	22-1/16	65-3/4
220	56	130	96	166	24-7/8	13-3/16	22	48	29-5/8	19	14-1/4	12-3/8	25-1/16	87-3/8
222	56	130	96	166	27-3/8	13-3/16	22	48	24-5/8	19	14-1/4	12-3/8	27-9/16	87-3/8
225	68	154	96	172	31-3/8	17-9/16	28	48	37-5/8	12-5/16	20-1/4	15-3/8	31-1/2	111-3/8
230	68	154	96	172	36-7/8	17-9/16	28	48	26-5/8	12-5/16	20-1/4	15-3/8	37	111-3/8

Note: All dimensions in inches subject to manufacturing tolerances.

Figure 18. Vertical models sizes 215–230 with mixing box

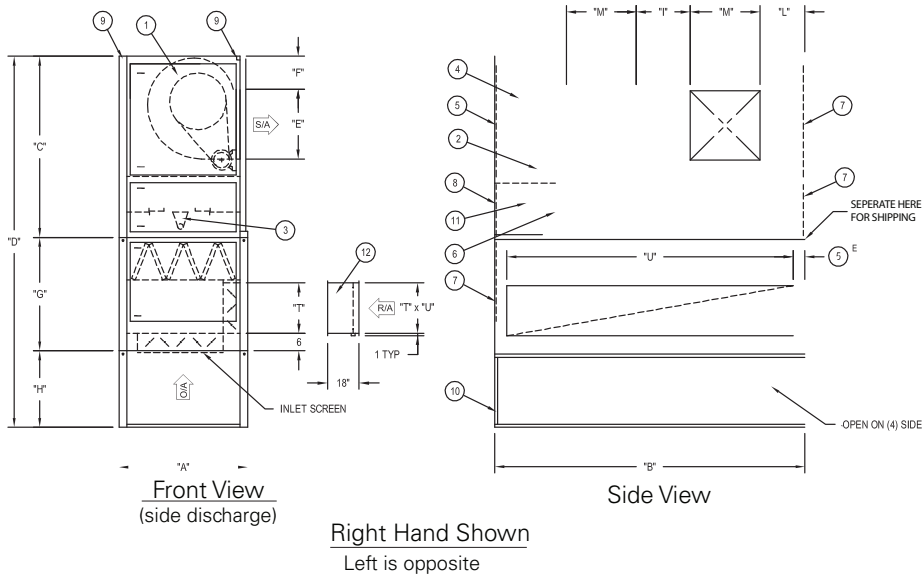

Unit Components

1. Centrifugal supply fan
2. Fan motor
3. Line burner
4. Control cabinet
5. Hinged control cabinet access door
6. Observation port
7. Access door
8. Access door (piping compartment)
9. Lifting lug
10. Unit support stand
11. Manifold compartment
12. Airflow station (required ETL listed return air unit)

Table 19. Dimensions for vertical models sizes 215–230 with mixing box

Model	A	B	C	D	E	F	G	H	I	L	M	T	U
215	42	94	77	167	16	12-3/8	54	36	22-1/4	7-7/8	18-15/16	20-1/4	84
218	42	94	77	167	19	12-3/8	54	36	16	7-7/8	22-1/16	20-1/4	84
220	56	130	96	204	24-7/8	13-3/16	60	48	29-5/8	12-3/8	25-1/16	20-1/4	120
222	56	130	96	204	27-3/8	13-3/16	60	48	24-5/8	12-3/8	27-9/16	20-1/4	120
225	68	154	96	209	31-3/8	17-9/16	65	48	37-5/8	15-3/8	31-1/2	26-1/2	144
230	68	154	96	209	36-7/8	17-9/16	65	48	26-5/8	15-3/8	37	26-1/2	144

Note: All dimensions in inches subject to manufacturing tolerances.

Figure 19. Vertical models sizes 233 and 240

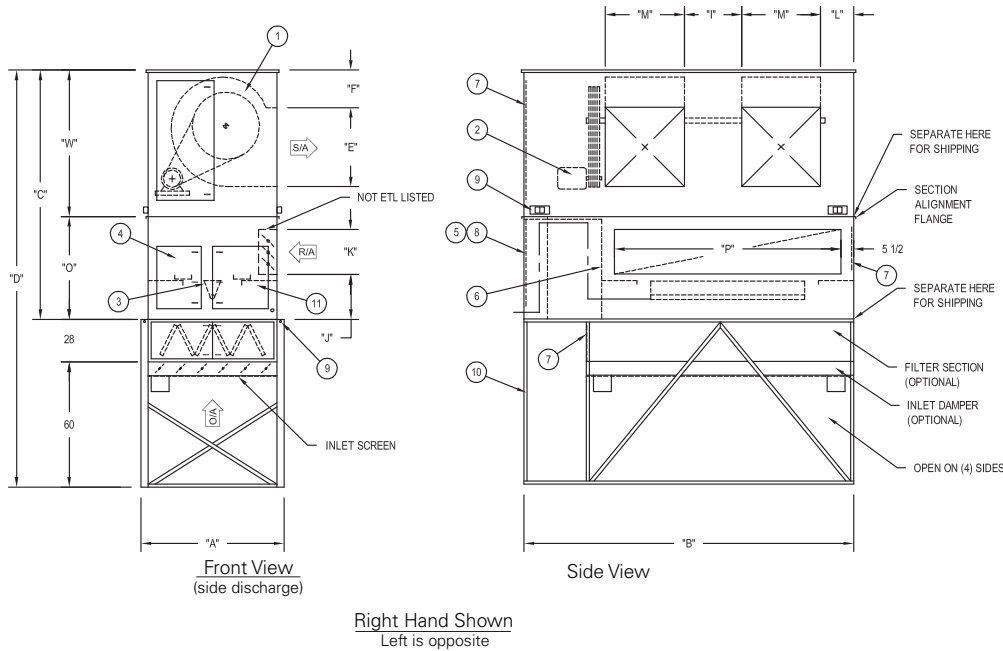

Unit Components

1. Centrifugal supply fan
2. Fan motor
3. Line burner
4. Control cabinet
5. Hinged control cabinet access door
6. Observation port
7. Access door
8. Access door (piping compartment)
9. Lifting lug
10. Unit support stand
11. Manifold compartment

Table 20. Dimensions vertical models sizes 233 and 240

Model	A	B	C	D	E	F	I	J	K	L	M	O	P	W
233	76	175	117	205	43-1/16	19-7/16	36	20	20-1/4	17	39-7/8	45	130	72
240	87-1/4	210	131	219	41	33	39-7/8	20	20-1/4	20	53-7/8	45	166	86

Note: All dimensions in inches subject to manufacturing tolerances.

Figure 20. Vertical models 233 and 240 with mixing box

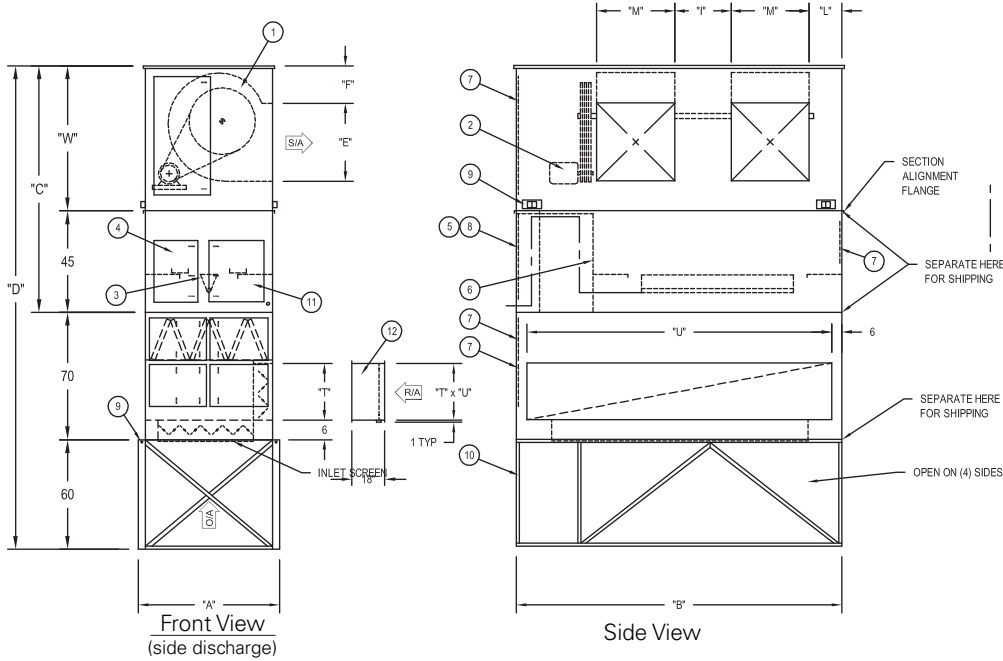

Unit Components

1. Centrifugal supply fan
2. Fan motor
3. Line burner
4. Control cabinet
5. Hinged control cabinet access door
6. Observation port
7. Access door
8. Access door (piping compartment)
9. Lifting lug
10. Unit support stand
11. Manifold compartment

Right Hand Shown
Left is opposite

Table 21. Dimensions for vertical models 233 and 240 with mixing box

Model	A	B	C	D	E	F	I	L	M	T	U	W
233	76	175	117	247	43-1/16	19-7/16	36	17	39-7/8	31-1/4	163	72
240	87-1/4	210	131	261	41	33	39-7/8	20	58-7/8	31-1/4	198	86

Note: All dimensions in inches subject to manufacturing tolerances.

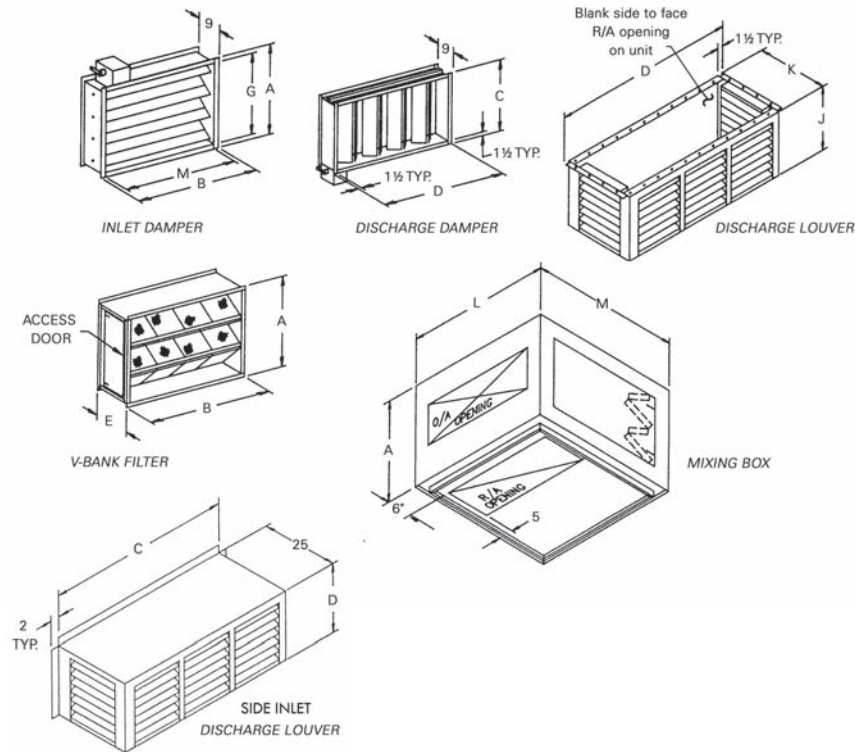
Figure 21. DFOA Accessories dimensional data

Table 22. DFOA Accessories dimensional data

Model	A	B	C	D	E	F	G	H	J	K	L	M
109-112	3' 0"	3' 11-1/4"	1' 5-7/16"	1' 8-13/16"	1' 10"	5' 1-3/4"	2' 8-1/4"	3' 7-1/8"	1' 9"	1' 11"	4' 4"	4' 6"
914	1200	443	529	559	1568	819	1095	533	584	1321	1372	
115-118	3' 0"	3' 11-1/4"	1' 10-7/8"	2' 2-15/16"	1' 10"	5' 1-3/4"	2' 8-1/4"	3' 7-1/8"	2' 0"	1' 11"	4' 4"	4' 6"
914	1200	581	684	559	1568	819	1095	610	660	1321	1372	
215-218	3' 0"	7' 7-1/2"	1' 10-7/8"	5' 4-7/8"	1' 10"	5' 1-3/4"	2' 8-1/4"	7' 3-3/8"	2' 0"	1' 11"	7' 10"	4' 6"
914	2324	581	1648	559	1568	819	2219	610	660	2388	1372	
220-222	4' 0"	8' 5-5/8"	2' 7-1/4"	7' 0-1/2"	1' 10"	5' 5-3/4"	3' 8-1/4"	8' 1-1/2"	3' 9"	2' 7"	10' 10"	5' 0"
1219	2581	794	2146	559	1670	1124	2477	1143	787	3302	1524	
225-230	5' 0"	10' 1-3/8"	3' 4-3/4"	8' 9-3/8"	2' 4"	7' 2-1/8"	4' 8-1/4"	9' 9-1/4"	3' 9"	3' 4-3/4"	12' 10"	5' 5"
1524	3083	1035	2677	711	2188	1429	2978	1143	1035	3912	1651	

Model	R / A / ID
109-118	3' 6" x 1' 8-1/4" (1067 x 514)
215-218	7' x 1' 8-1/4" (2134 x 514)
220-222	0' x 1' 8-1/4" (3048 x 514)
225-230	12' x 2' 2-1/2" (3658 x 673)

Roof curbs for 100% make-up air units

Figure 22. Single blower roof curb dimensions

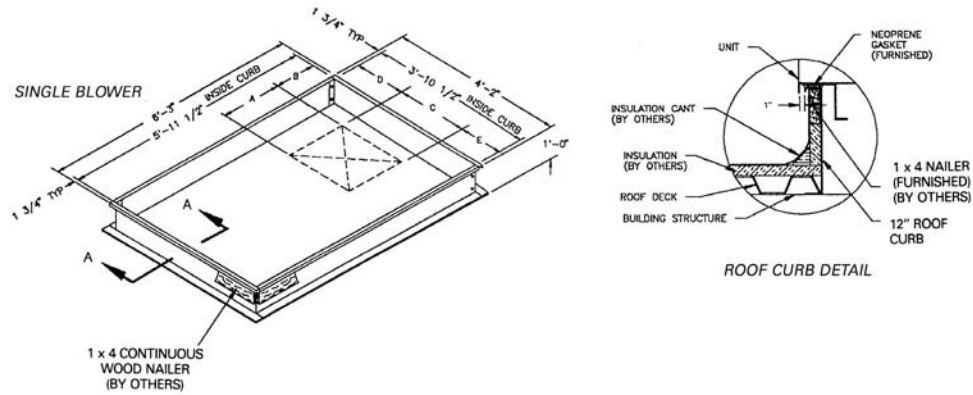

Table 23. Dimensions for single blower roof curb model sizes 109–118

Model	A	B	C	D	E
109	10-3/8"	1' 0-3/8"	11-15/16"	11-3/4"	1' 10-13/16"
	264	314	303	298	579
112	1' 1-9/16"	10-13/16"	1' 3-15/16"	9-3/4"	1' 8-13/16"
	344	275	405	248	529
115	1' 4"	9-5/8"	1' 6-15/16"	8-3/8"	1' 7-3/16"
	406	244	481	213	487
118	1' 7"	9-5/8"	1' 10-1/16"	5-1/8"	1' 7-5/16"
	483	244	560	130	491

Roof curbs for 100% make-up air units

Figure 23. Double blower roof curb dimensions

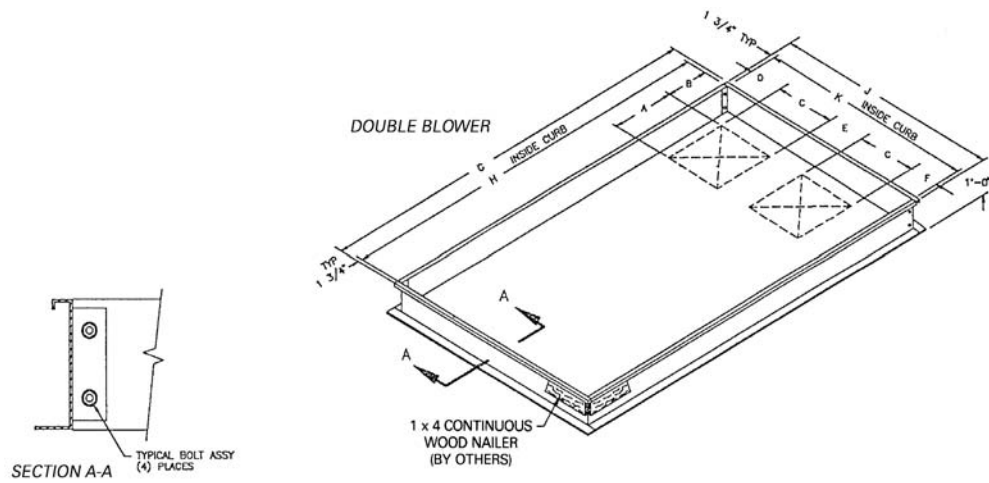

Table 24. Double blower roof curb dimensions for model sizes 215–230

Model	A	B	C	D	E	F	G	H	J	K
215	1' 4"	9-5/8"	1' 6-15/16"	5-1/8"	1' 10-1/4"	1' 11-1/4"	6' 3"	5' 11-1/2"	7' 8"	7' 4-1/2"
406	244	481	130	565	591	1905	1816	2337	2248	
218	1' 7"	9-5/8"	1' 10-1/16"	5-1/8"	1' 4"	1' 11-1/4"	6' 3"	5' 11-1/2"	7' 8"	7' 4-1/2"
483	244	560	130	406	591	1905	1816	2337	2248	
220	2' 0-7/8"	10-7/16"	2' 1-1/16"	9-5/8"	2' 5-5/8"	2' 11-1/8"	7' 10"	7' 6-1/2"	10' 8"	10' 4-1/2"
632	265	637	244	752	892	2388	2299	3251	3162	
222	2' 3-3/8"	10-7/16"	2' 3-9/16"	9-5/8"	2' 0-5/8"	2' 11-1/8"	7' 10"	7' 6-1/2"	10' 8"	10' 4-1/2"
695	265	700	244	625	892	2388	2299	3251	3162	
225	2' 7-3/8"	1' 2-13/16"	2' 7-1/2"	1' 0-5/8"	3' 1-5/8"	2' 11-1/4"	7' 10"	7' 6-1/2"	12' 8"	12' 4-1/2"
797	376	800	321	956	895	2388	2299	3861	3772	
230	3' 0-7/8"	1' 2-13/16"	3' 1"	1' 0-5/8"	2' 2-5/8"	2' 11-1/4"	7' 10"	7' 6-1/2"	12' 8"	12' 4-1/2"
937	376	940	321	676	895	2388	2299	3861	3772	

Notes:

1. Curb to be shipped loose and assembled in the field.
2. Curb must be square and level
3. Curb requires intermediate structural support and is not to be corner post mounted.
4. Gaskets to be shipped with unit.
5. Bolting accessories shipped with curb.
6. Curb drawings shown are for units which have controls on the "standard" side.
7. Available on horizontal units only.

Roof curbs for units with return air opening downstream of burner

Figure 24. Roof curb dimensions for single blower models sizes 109–118

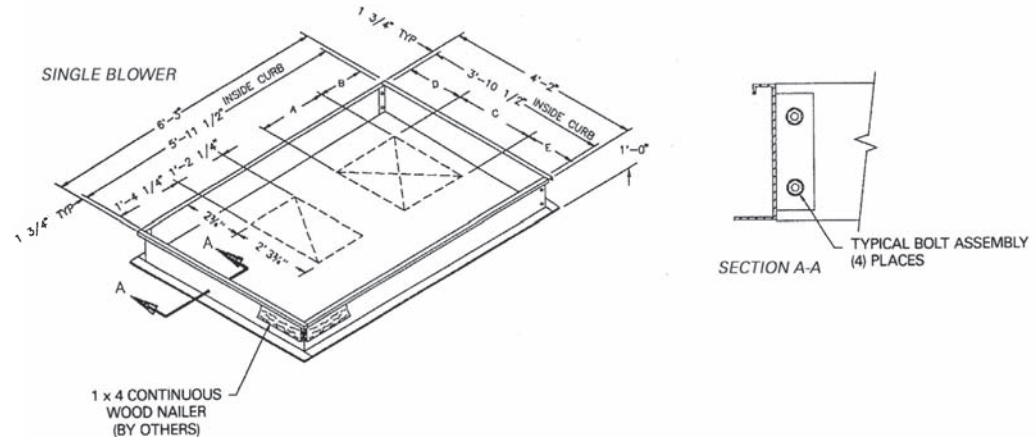

Table 25. Dimensions for roof curb single blower models sizes 109–118

Model	A	B	C	D	E
109	10-3/8"	1' 0-3/8"	11-15/16"	11-3/4"	1' 10-13/16"
	264	314	303	298	579
112	1' 1-9/16"	10-13/16"	1' 3-15/16"	9-3/4"	1' 8-13/16"
	344	275	405	248	529
115	1' 4"	9-5/8"	1' 6-15/16"	8-3/8"	1' 7-3/16"
	406	244	481	213	487
118	1' 7"	9-5/8"	1' 10-1/16"	5-1/8"	1' 7-5/16"
	483	244	560	130	491

Roof curbs for units with return air opening downstream of burner

Figure 25. Roof curb dimensions for double blower models sizes 215–230

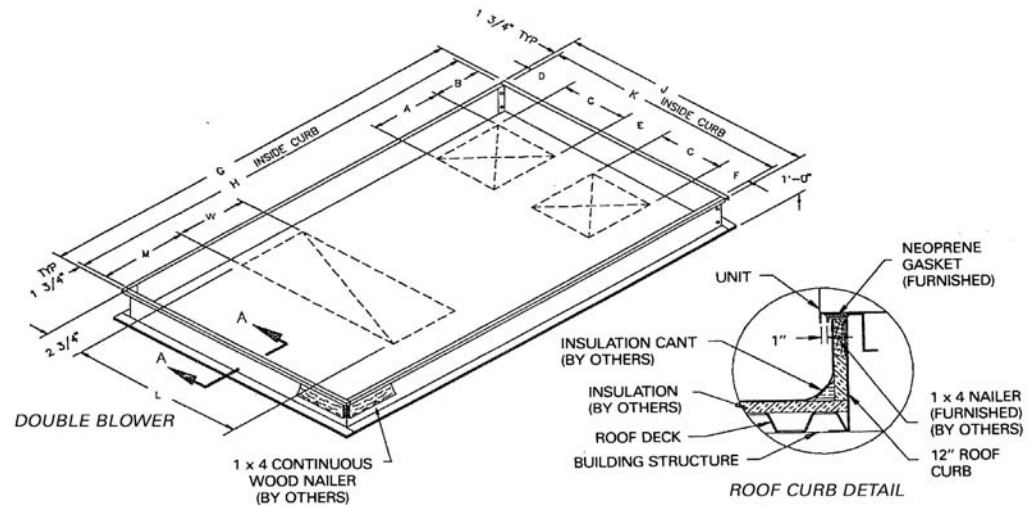

Table 26. Roof curb dimensions for double blower models sizes 215–230

Model	A	B	C	D	E	F	G
215	1' 4"	9-5/8"	1' 6-15/16"	5-1/8"	1' 10-1/4"	1' 11-1/4"	6' 3"
	406	244	481	130	565	591	1905
218	1' 7"	9-5/8"	1' 10-1/16"	5-1/8"	1' 4"	1' 11-1/4"	6' 3"
	483	244	560	130	406	591	1905
220	2' 0-7/8"	10-7/16"	2' 1-1/16"	9-5/8"	2' 5-5/8"	2' 11-1/8"	7' 10"
	632	265	637	244	752	892	2388
222	2' 3-3/8"	10-7/16"	2' 3-9/16"	9-5/8"	2' 0-5/8"	2' 11-1/8"	7' 10"
	695	265	700	244	625	892	2388
225	2' 7-3/8"	1' 2-13/16"	2' 7-1/2"	1' 0-5/8"	3' 1-5/8"	2' 11-1/4"	7' 10"
	797	376	800	321	956	895	2388
230	3' 0-7/8"	1' 2-13/16"	3' 1"	1' 0-5/8"	2' 2-5/8"	2' 11-1/4"	7' 10"
	937	376	940	321	676	895	2388

Model	H	J	K	L	M	W
215	5' 11-1/2"	7' 8"	7' 4-1/2"	5' 5-3/4"	1' 4-1/4"	1' 2-1/4"
	1816	2337	2248	1670	413	362
218	5' 11-1/2"	7' 8"	7' 4-1/2"	5' 5-3/4"	1' 4-1/4"	1' 2-1/4"
	1816	2337	2248	1670	413	362
220	7' 6-1/2"	10' 8"	10' 4-1/2"	7' 3-3/8"	1' 4-1/4"	1' 2-1/4"
	2299	3251	3162	2219	413	362
222	7' 6-1/2"	10' 8"	10' 4-1/2"	7' 3-3/8"	1' 4-1/4"	1' 2-1/4"
	2299	3251	3162	2219	413	362
225	7' 6-1/2"	12' 8"	12' 4-1/2"	9' 3-3/8"	9-9/16"	1' 8-1/4"
	2299	3861	3772	2829	243	514
230	7' 6-1/2"	12' 8"	12' 4-1/2"	9' 3-3/8"	9-9/16"	1' 8-1/4"
	2299	3861	3772	2829	243	514

Roof curbs for units with mixing box

Figure 26. Roof curb dimensions for single blower units with mixing box

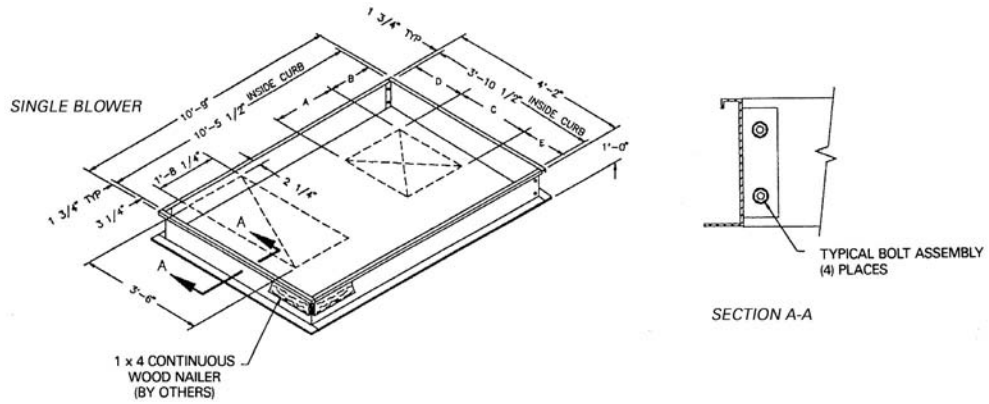

Table 27. Roof curb dimensions for single blower units with mixing box models sizes 109–118

Model	A	B	C	D	E
109	10-3/8"	1' 0-3/8"	11-15/16"	11-3/4"	1' 10-13/16"
	264	314	303	298	579
112	1' 1-9/16"	10-13/16"	1' 3-15/16"	9-3/4"	1' 8-13/16"
	344	275	405	248	529
115	1' 4"	9-5/8"	1' 6-15/16"	8-3/8"	1' 7-3/16"
	406	244	481	213	487
118	1' 7"	9-5/8"	1' 10-1/16"	5-1/8"	1' 7-5/16"
	483	244	560	130	491

Roof curbs for units with mixing boxes

Figure 27. Roof curb dimensions for double blower units with mixing box

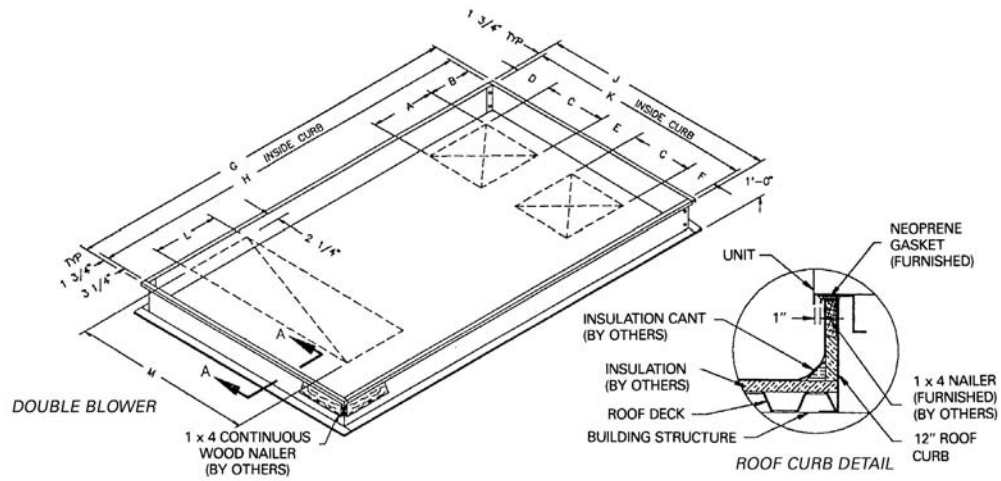

Table 28. Roof curb dimensions for double blower units with mixing box models sizes 215–230

Model	A	B	C	D	E	F	G	H	J	K	L	M
215	1' 4"	9-5/8"	1' 6-15/16"	5-1/8"	1' 10-1/4"	1' 11-1/4"	10' 9"	10' 5-1/2"	7' 8"	7' 4-1/2"	1' 8-1/4"	7' 0"
	406	244	481	130	565	591	3277	3188	2337	2248	514	2134
218	1' 7"	9-5/8"	1' 10-1/16"	5-1/8"	1' 4"	1' 11-1/4"	10' 9"	10' 5-1/2"	7' 8"	7' 4-1/2"	1' 8-1/4"	7' 0"
	483	244	560	130	406	591	3277	3188	2337	2248	514	2134
220	2' 0-7/8"	10-7/16"	2' 1-1/16"	9-5/8"	2' 5-5/8"	2' 11-1/8"	12' 10"	12' 6-1/2"	10' 8"	10' 4-1/2"	1' 8-1/4"	10' 0"
	632	265	637	244	752	892	3912	3823	3251	3162	514	3048
222	2' 3-3/8"	10-7/16"	2' 3-9/16"	9-5/8"	2' 0-5/8"	2' 11-1/8"	12' 10"	12' 6-1/2"	10' 8"	10' 4-1/2"	1' 8-1/4"	10' 0"
	695	265	700	244	625	892	3912	3823	3251	3162	514	3048
225	2' 7-3/8"	1' 2-13/16"	2' 7-1/2"	1' 0-5/8"	3' 1-5/8"	2' 11-1/4"	13' 3"	12' 11-1/2"	12' 8"	12' 4-1/2"	2' 2-1/2"	12' 0"
	797	376	800	321	956	895	4039	3950	3861	3772	673	3658
230	3' 0-7/8"	1' 2-13/16"	3' 1"	1' 0-5/8"	2' 2-5/8"	2' 11-1/4"	13' 3"	12' 11-1/2"	12' 8"	12' 4-1/2"	2' 2-1/2"	12' 0"
	937	376	940	321	676	895	4039	3950	3861	3772	673	3658

Notes:

1. Curb to be shipped loose and assembled in the field.
2. Curb must be square and level.
3. Curb requires intermediate structural support and is not to be corner post mounted.
4. Gaskets to be shipped with unit.
5. Bolting accessories shipped with curb.
6. Curb drawings shown are for units which have controls on the "standard" side.
7. Available on horizontal units only.

Approximate weights

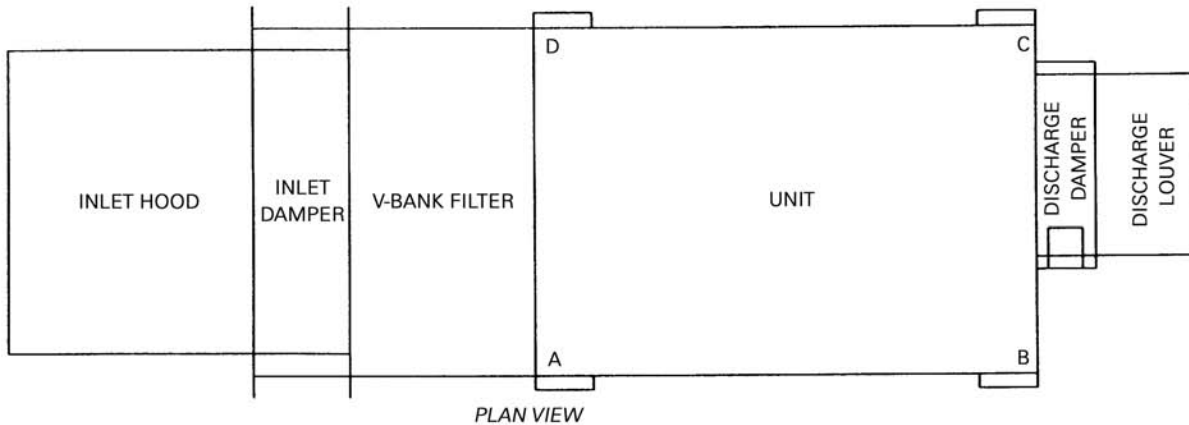
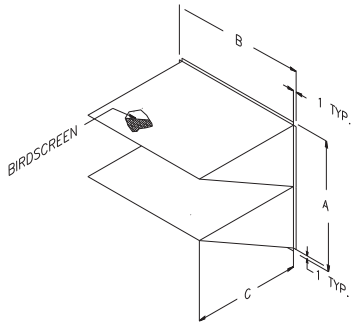

Table 29. Unit weights in pounds (approximate)

Unit Size	Basic Horizontal Unit	Basic Vertical Unit	Inlet Hood	Inlet Damper	V-bank Filter	Mixing Box	Air Flow Station	Discharge Damper	Discharge Louver	A	B	C	D
109	760	984	170	75	105	480	47	30	70	215	215	185	145
112	760	984	170	75	105	480	47	30	70	215	215	185	145
115	760	984	170	75	105	480	47	30	70	215	215	185	145
118	810	1034	170	75	105	480	47	30	70	225	225	200	160
215	1180	1607	275	135	175	700	80	100	150	342	342	274	222
218	1300	1727	275	135	175	700	80	100	150	378	378	311	233
220	2280	3179	320	200	230	980	111	145	215	625	625	555	475
222	2370	3269	320	200	230	980	111	145	215	675	675	545	475
225	2990	4135	500	275	340	1270	135	210	230	824	824	732	610
230	3130	4275	720	275	340	1270	135	210	230	863	863	731	673

Table 30. Roof curb weights in pounds

Description	Unit Sizes									
	109	112	115	118	215	218	220	222	225	230
Roof Curb for Basic Frame—No Return Air	150	150	150	150	200	200	270	270	300	300
Roof Curb for Basic Frame—With Return Air Downstream of Burner	150	150	150	150	200	200	270	270	300	300
Roof Curb for Basic Frame—With Mixing Box Option	215	215	215	215	270	270	340	340	375	375

Figure 28. Inlet hood support (by others)



FOR MODELS 115-118, 215-218, 220-222

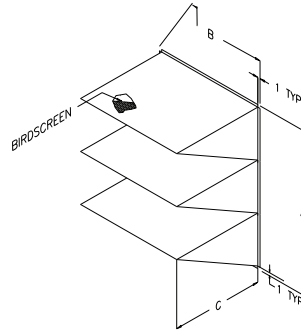

FOR MODELS 225-230

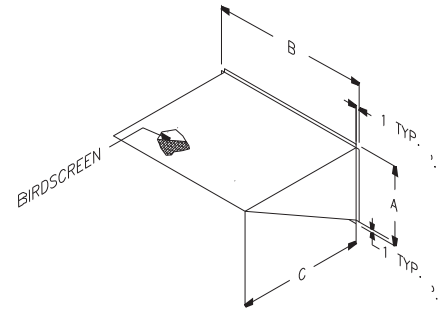

FOR MODELS 109-112

Inlet Hood Support (By Others)

- The purpose of hood support is to support the weight of the unit accessories which are attached to the inlet of the basic unit.
- The hood support can be made from two, 2" x 2" x 1/4" angle iron.
- One angle iron support should be located in, or close to, the outer corners of the hood. The supports can be bolted to the hood.
- The bottom of the angle iron support should be fitted with a base. The base can sit on the roof and does not have to be fixed to the roof. An isolation pad may be put between the base and the roof.

Model	A	B	C
109-112	3' 0"	3' 11-1/4"	1' 5-7/16"
	914	1200	443
115-118	3' 0"	3' 11-1/4"	1' 10-7/8"
	914	1200	581
215-218	3' 0"	7' 7-1/2"	1' 10-7/8"
	914	2324	581
220-222	4' 0"	8' 5-5/8"	2' 7-1/4"
	1219	2581	794
225-230	5' 0"	10' 1-3/8"	3' 4-3/4"
	1524	3083	1035

Gas Piping

Figure 29. Gas piping

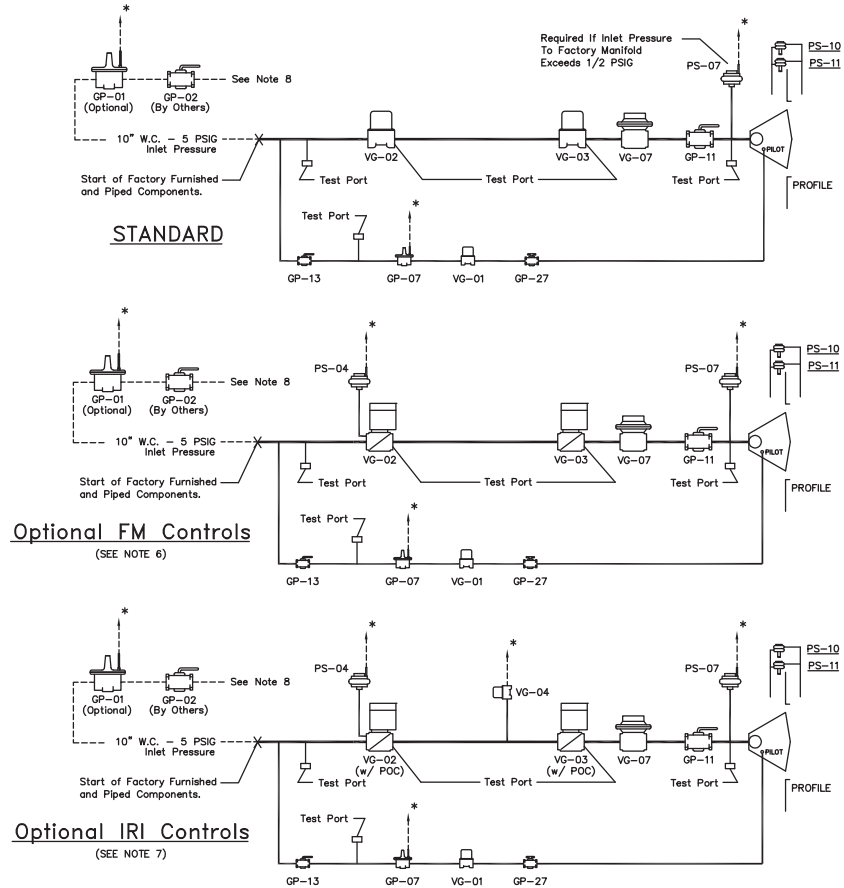

Table 31. Gas piping component identification

GP-01	High Gas Pressure Regulator	VG-03	Auxiliary Gas Valve
GP-02	Main Gas Shut-off Valve	VG-04	N/O Vent Valve
GP-09	Pilot Gas Pressure Regulator	VG-07	Modulating Valve
GP-11	Main Test Firing Shut-off Valve	PS-04	Low Gas Pressure Switch
GP-13	Pilot Gas Shut-off Valve	PS-07	High Gas Pressure Switch
GP-27	Orificed Needle Valve	PS-10	High Velocity Pressure Switch
VG-01	Pilot Gas Valve	PS-11	Low Velocity Pressure Switch
VG-02	Main Gas Valve		

Notes:

1. Vent limiting devices provided wherever possible, when venting is required; the venting to outside is by others on indoor units and furnished by factory on outdoor units.
2. Units with 900 MBh and less use a pressure regulator (not shown) for high fire setting.
3. 3,300 MBh and above will require a minimum inlet pressure of 1 psig. For inlet pressures under 1 psig, please consult factory.
4. Units that are listed to the Z83.4 standard (100% Make-Up Air) carry both ETL and CETL approvals.
5. Standard manifold meets FM requirements for inputs under 2,500 MBh for ETL listed units
6. Standard manifold meets IRI requirements for ETL listed units.
7. High gas pressure regulator required if inlet pressure exceeds 1/2 psig for inputs up to and including 900 MBh or inlet pressures over 5 psig for inputs greater than 900 MBh.

Table 32. Gas pressure regulator selection

If Burner Size (BS) Is:	And Gas Pressure (GP) Is:	Then:
BS < 2200	GP < 7 in. wc	Call factory to verify availability and pricing
	7 in. wc < GP < 10 in. wc	Use low gas pressure burner
	10 in. wc < GP < 14 in. wc	No high gas pressure regulator required
	14 in. wc < GP < 1 psi	Use high gas pressure regulator 14 in. wc – 1 psi (shipped loose)
	1 psi < GP < 5 psi	Use high gas pressure regulator 1–5 psi (shipped loose)
	5 psi < GP < 10 psi	Use high gas pressure regulator 5–10 psi (shipped loose)
	10 psi < GP < 50 psi	Use high gas pressure regulator over 10 psi (shipped loose)
2475 < BS < 3025	50 psi < GP	Call factory to verify availability and pricing
	GP < 10 in. wc	Call factory to verify availability and pricing
	10 in. wc < GP < 14 in. wc	No high gas pressure regulator required
	14 in. wc < GP < 1 psi	Use high gas pressure regulator 14 in. wc – 1 psi (shipped loose)
	1 psi < GP < 5 PSI	Use high gas pressure regulator 1–5 psi (shipped loose)
	5 psi < GP < 10 psi	Use high gas pressure regulator 5–10 psi (shipped loose)
3300 < BS < 9075	10 psi < GP < 50 psi	Use high gas pressure regulator over 10 psi (shipped loose)
	50 psi < GP	Call factory to verify availability and pricing
	GP < 1 psi	Call factory to verify availability and pricing
	1 psi < GP < 5 psi	No high gas pressure regulator required
	5 psi < GP < 10 psi	Use high gas pressure regulator 5–10 psi (shipped loose)
	10 psi < GP < 50 psi	Use high gas pressure regulator over 10 psi (shipped loose)
	50 psi < GP	Call factory to verify availability and pricing

Examples of how to read the above:

- GP < 7 in. wc: Gas pressure less than 7 in. wc
- 7 in. wc ≤ GP < 10 in. wc: Gas pressure greater than or equal to 7 in. wc, and less than 10 in. wc
- 10 in. wc ≤ GP ≤ 14 in. wc: Gas pressure greater than or equal to 10 in. wc, and less than or equal to 14 in. wc
- 50 psi < GP: Gas pressure greater than 50 psi

Gas Piping

Table 33. Gas piping connection size, standard gas train

MBh	Inlet gas pressure (inches of water column)									
	7	8–11	12–14	15–20	21–27	1 psi	2 psi	3 psi	4 psi	5 psi
275	1	3/4	3/4	3/4	3/4	3/4	3/4	3/4	3/4	3/4
550	1-1/4	1	3/4	3/4	3/4	3/4	3/4	3/4	3/4	3/4
825	2	1-1/4	1-1/4	1-1/4	1-1/4	1-1/4	1-1/4	1-1/4	1-1/4	1-1/4
1,100	2	1-1/4	1-1/4	1-1/4	1-1/4	1-1/4	1-1/4	1-1/4	1-1/4	1-1/4
1,375	2	1-1/2	1-1/4	1-1/4	1-1/4	1-1/4	1-1/4	1-1/4	1-1/4	1-1/4
1,650	—	1-1/2	1-1/4	1-1/4	1-1/4	1-1/4	1-1/4	1-1/4	1-1/4	1-1/4
1,925	—	2	1-1/2	1-1/4	1-1/4	1-1/4	1-1/4	1-1/4	1-1/4	1-1/4
2,200	—	2	1-1/2	1-1/4	1-1/4	1-1/4	1-1/4	1-1/4	1-1/4	1-1/4
2,475	—	2	2	1-1/2	1-1/4	1-1/4	1-1/4	1-1/4	1-1/4	1-1/4
2,750	—	2	2	1-1/2	1-1/4	1-1/4	1-1/4	1-1/4	1-1/4	1-1/4
3,025	—	—	2	2	2	2	2	2	2	2
3,300	—	—	2	2	2	2	2	2	2	2
3,575	—	—	—	—	2	2	2	2	2	2
3,850	—	—	—	—	2	2	2	2	2	2
4,125	—	—	—	—	2	2	2	2	2	2
4,400	—	—	—	—	2	2	2	2	2	2
4,675	—	—	—	—	2	2	2	2	2	2
4,950	—	—	—	—	2	2	2	2	2	2
5,225	—	—	—	—	2	2	2	2	2	2
5,500	—	—	—	—	2	2	2	2	2	2
5,775	—	—	—	—	2	2	2	2	2	2
6,050	—	—	—	—	2	2	2	2	2	2
6,325	—	—	—	—	2-1/2	2-1/2	2-1/2	2-1/2	2-1/2	2-1/2
6,600	—	—	—	—	2-1/2	2-1/2	2-1/2	2-1/2	2-1/2	2-1/2
6,875	—	—	—	—	2-1/2	2-1/2	2-1/2	2-1/2	2-1/2	2-1/2
7,150	—	—	—	—	2-1/2	2-1/2	2-1/2	2-1/2	2-1/2	2-1/2
7,700	—	—	—	—	2-1/2	2-1/2	2-1/2	2-1/2	2-1/2	2-1/2
8,250	—	—	—	—	2-1/2	2-1/2	2-1/2	2-1/2	2-1/2	2-1/2
8,800	—	—	—	—	2-1/2	2-1/2	2-1/2	2-1/2	2-1/2	2-1/2
9,350	—	—	—	—	3	3	3	3	3	3

Table 34. Gas pipe connection size, FM gas train

MBh	Inlet gas pressure (inches of water column)									
	7	8–11	12–14	15–20	21–27	1 psi	2 psi	3 psi	4 psi	5 psi
275	1	3/4	3/4	3/4	3/4	3/4	3/4	3/4	3/4	3/4
550	1-1/4	1	3/4	3/4	3/4	3/4	3/4	3/4	3/4	3/4
825	1-1/4	1-1/4	1	1	3/4	—	—	—	—	—
1,100	1 ½	1-1/4	1-1/4	1-1/4	1-1/4	1-1/4	1-1/4	1-1/4	1-1/4	1-1/4
1,375	2	1-1/2	1-1/4	1-1/4	1-1/4	1-1/4	1-1/4	1-1/4	1-1/4	1-1/4
1,650	2	1-1/2	1-1/4	1-1/4	1-1/4	1-1/4	1-1/4	1-1/4	1-1/4	1-1/4
1,925	2	2	1-1/2	1-1/4	1-1/4	1-1/4	1-1/4	1-1/4	1-1/4	1-1/4
2,200	—	2	1-1/2	1-1/4	1-1/4	1-1/4	1-1/4	1-1/4	1-1/4	1-1/4
2,475	—	2	2	1-1/2	1-1/4	1-1/4	1-1/4	1-1/4	1-1/4	1-1/4
2,750	—	2-1/2	2	1-1/2	1-1/4	1-1/4	1-1/4	1-1/4	1-1/4	1-1/4
3,025	—	3	2	—	—	—	—	—	—	—
3,300	—	3	2-1/2	2	2	2	2	2	2	2
3,575	—	—	—	—	—	2	2	2	2	2
3,850	—	—	—	—	—	2	2	2	2	2
4,125	—	—	—	—	—	2	2	2	2	2
4,400	—	—	—	—	—	2	2	2	2	2
4,675	—	—	—	—	—	2	2	2	2	2
4,950	—	—	—	—	—	2	—	—	—	—
5,225	—	—	—	—	—	2	—	—	—	—
5,500	—	—	—	—	—	2	—	—	—	—
5,775	—	—	—	—	—	2	—	—	—	—
6,050	—	—	—	—	—	2	—	—	—	—
6,325	—	—	—	—	—	2-1/2	2-1/2	2-1/2	2-1/2	2-1/2
6,600	—	—	—	—	—	2-1/2	2-1/2	2-1/2	2-1/2	2-1/2
6,875	—	—	—	—	—	2-1/2	2-1/2	2-1/2	2-1/2	2-1/2
7,150	—	—	—	—	—	2-1/2	2-1/2	2-1/2	2-1/2	2-1/2
7,700	—	—	—	—	—	2-1/2	2-1/2	2-1/2	2-1/2	2-1/2
8,250	—	—	—	—	—	2-1/2	—	—	—	—
8,800	—	—	—	—	—	2-1/2	—	—	—	—
9,350	—	—	—	—	—	3	3	3	3	3



Gas Piping

Table 35. Gas pipe connection size, IRI gas train

MBh	Inlet gas pressure (inches of water column)									
	7	8–11	12–14	15–20	21–27	1 psi	2 psi	3 psi	4 psi	5 psi
275	1	3/4	3/4	3/4	3/4	3/4	3/4	3/4	3/4	3/4
550	1-1/4	1	3/4	3/4	3/4	3/4	3/4	3/4	3/4	3/4
825	1-1/4	1-1/4	3/4	3/4	1-1/4	1-1/4	1-1/4	1-1/4	1-1/4	1-1/4
1,100	2	1-1/2	1-1/4	1-1/4	1-1/4	1-1/4	1-1/4	1-1/4	1-1/4	1-1/4
1,375	2-1/2	2	1-1/4	1-1/4	1-1/4	1-1/4	1-1/4	1-1/4	1-1/4	1-1/4
1,650	2-1/2	2	1-1/4	1-1/4	1-1/4	1-1/4	1-1/4	1-1/4	1-1/4	1-1/4
1,925	2-1/2	2	1-1/4	1-1/4	1-1/4	1-1/4	1-1/4	1-1/4	1-1/4	1-1/4
2,200	2-1/2	2	1-1/2	1-1/2	1-1/4	1-1/4	1-1/4	1-1/4	1-1/4	1-1/4
2,475	—	2	1-1/2	1-1/2	1-1/4	1-1/4	1-1/4	1-1/4	1-1/4	1-1/4
2,750	—	2-1/2	2	1-1/2	—	1-1/4	1-1/4	1-1/4	1-1/4	1-1/4
3,025	—	2-1/2	2	—	—	—	—	—	—	—
3,300	—	2-1/2	2	2	2	2	2	2	2	2
3,575	—	—	—	—	—	2	2	2	2	2
3,850	—	—	—	—	—	2	2	2	2	2
4,125	—	—	—	—	—	2	2	2	2	2
4,400	—	—	—	—	—	2	2	2	2	2
4,675	—	—	—	—	—	2	2	2	2	2
4,950	—	—	—	—	—	2	2	2	2	2
5,225	—	—	—	—	—	2	2	2	2	2
5,500	—	—	—	—	—	2	2	2	2	2
5,775	—	—	—	—	—	2	—	—	—	—
6,050	—	—	—	—	—	2-1/2	2-1/2	2-1/2	2-1/2	2-1/2
6,325	—	—	—	—	—	2-1/2	2-1/2	2-1/2	2-1/2	2-1/2
6,600	—	—	—	—	—	2-1/2	2-1/2	2-1/2	2-1/2	2-1/2
6,875	—	—	—	—	—	2-1/2	2-1/2	2-1/2	2-1/2	2-1/2
7,150	—	—	—	—	—	2-1/2	2-1/2	2-1/2	2-1/2	2-1/2
7,700	—	—	—	—	—	2-1/2	2-1/2	2-1/2	2-1/2	2-1/2
8,250	—	—	—	—	—	2-1/2	2-1/2	2-1/2	2-1/2	2-1/2
8,800	—	—	—	—	—	2-1/2	—	—	—	—
9,350	—	—	—	—	—	3	3	3	3	3

Electrical Power

Table 36. Motor electrical data

hp	Single Phase			Three Phase		
	115	208	230	208	230	460
1/3	7.2	4	3.6	1.4	1.6	0.7
1/2	9.8	5.4	4.9	2.4	2.2	1.1
3/4	13.8	7.6	6.9	3.5	3.2	1.6
1	16	8.8	8	4.6	4.2	2.1
1-1/2	20	11	10	6.6	6	3
2	24	13.2	12	7.5	6.8	3.4
3	34	18.7	17	10.6	9.6	4.8
5	56	30.8	28	16.7	15.2	7.6
7-1/2	—	—	—	24.2	22	11
10	—	55	—	30.8	28	14
15	—	—	—	46.2	42	21
20	—	—	—	59.4	54	27
25	—	—	—	74.8	68	34
30	—	—	—	88	80	40
40	—	—	—	114	104	52
50	—	—	—	143	130	65
60	—	—	—	169	154	77

Notes:

1. Amps taken from table 430-148 (single phase) and 430-150(three phase) of the 2002 edition of NEC. Actual motor amps are dependent on motor type and will be on name plate.
2. For units without a service receptacle: MCA = (Motor FLA*1.25) + (500VA transformer amps)
3. For units with a service receptacle: MCA = (Motor FLA*1.25) + (500VA transformer amps) + (1000VA transformer amps)

Table 37. Primary voltage

	115	208	230	460
500 VA	4.3	2.4	2.2	460
1000 VA	8.6	4.8	4.3	2.2

Options

Motorized 75/25 Damper

Purpose

To provide a way for recirculating return air and letting building pressure control the amount of air which is recirculated.

Operation

If building pressure is less than desired, the RA damper modulates to a more closed position and the interlocked burner profile damper modulates to a more open position. More OA is brought into building.

If building pressure is greater than desired, the RA damper modulates to a more open position and the interlocked burner profile damper modulates to a more closed position. Less OA is brought into building.

At no time will the unit provide less than 25 percent OA to the building. In general terms, the minimum OA is 25 percent; however, there are cases where it can be as high as 40–50 percent, depending upon unit size, burner size, gas train type and gas pressure.

Code requires that outside ventilation air be provided to the space in the amount of 4 cfm per 1 MBh of burner rated input.

All units are provided with a means that will allow the customer to interlock OA fans when the amount of OA provided by the unit is not sufficient to meet the 4 cfm per 1 MBh requirement.

Notes:

-
- This option can be used with either the Motorized Inlet Damper option or the Motorized Outlet Damper option.

Option Includes:

- Return air section with damper
- Burner profile damper
- Linkage
- Modulating damper motor(s)
- Photohelic differential pressure gauge

Figure 30. Motorized 75/25 damper

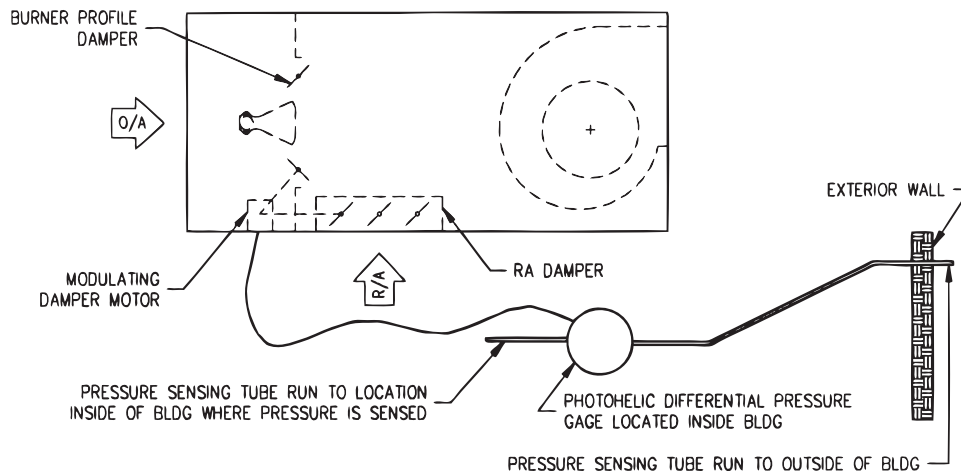

Mixing Box—Temperature Control

Purpose

To provide a way for recirculating return air and letting mixed air temperature determine the amount of OA/RA.

Operation

A temperature sensor located after the V-bank filter modulates the OA and RA dampers to maintain a set temperature.

If temperature at sensor is cooler than setting, OA damper modulates to a more closed position, and RA damper modulates to a more open position.

If temperature at sensor is warmer than setting, OA damper modulates to a more open position, and RA damper modulates to a more closed position. The minimum OA damper position is factory set at 25 percent supply air.

The desired temperature at the temperature sensor is set at the control cabinet at the unit.

Option Includes:

- Inlet damper
- Return air section with damper
- Modulating damper motor(s)
- V-bank filter with throwaway filters (DFIA)/Permanent (DFOA)
- Temperature sensor

Figure 31. Mixing box—Temperature control

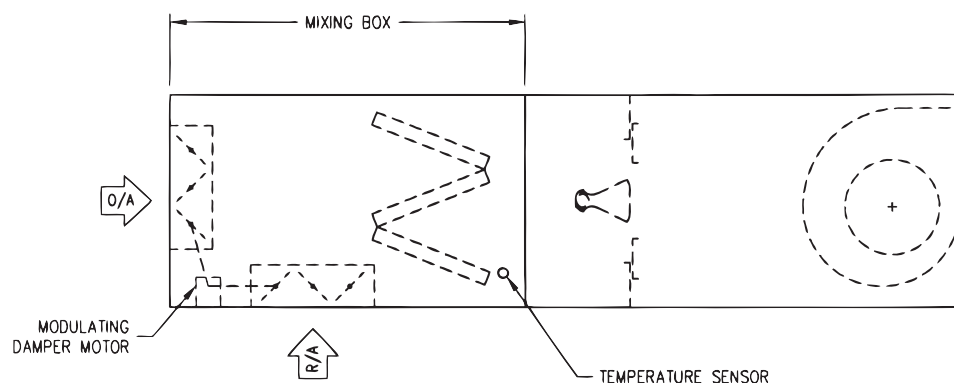

Mixing Box—Manual Control

Purpose

To provide a way for recirculating return air and using manual control to determine the amount of OA/RA.

Operation

A manual potentiometer located at the remote control station determines the OA/RA setting. The minimum OA damper position is factory set with a potentiometer. The minimum OA damper opening is set at 4 cfm per 1 MBh of burner rated input, or 25 percent supply air, whichever is larger.

Options Include:

- Mixing box with V-bank filter and permanent filters (DFOA)/TA (DFIA)

- Dampers
- Modulating damper motor(s)
- Manual potentiometer Remote control station not included.

Figure 32. Mixing box—Manual control

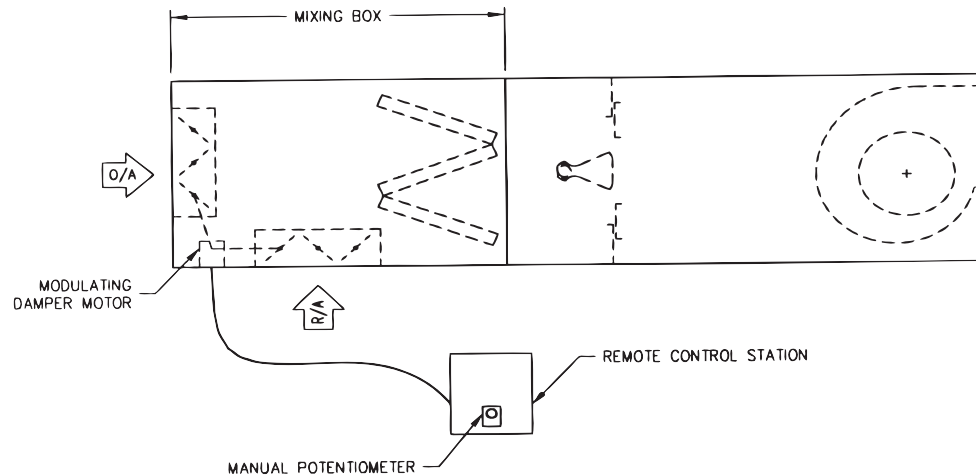

Purpose

To provide a way for recirculating return air and using manual control to determine the amount of OA/RA.

Operation

A manual potentiometer located at the remote control station determines the OA/RA setting. The minimum OA damper position is factory set with a potentiometer. The minimum OA damper opening is set at 4 cfm per 1 MBh of burner rated input, or 25 percent supply air, whichever is larger.

Options Include:

- Mixing box with V-bank filter and permanent filters (DFOA)/TA (DFIA)
- Dampers
- Modulating damper motor(s)
- Manual potentiometer

Note: Remote control station not included.

Mixing Box—Building Pressure Control

Purpose

To provide a way for recirculating return air and letting building pressure control the amount of air which is recirculated.

Operation

If building pressure is less than desired, the RA damper modulates to a more closed position and the OA damper modulates to a more open position. More OA is brought into building.

If building pressure is greater than desired, the RA damper modulates to a more open position and the OA damper modulates to a more closed position. Less OA is brought into building.

The minimum OA damper position is factory set with a potentiometer. The minimum OA damper position is set at 4 cfm per 1 MBh of burner rated input, or 25 percent supply air, whichever is larger.

The desired pressure differential is set at the photohelic.

Options Include:

- Mixing box with V-bank filter and permanent filters (DFOA)/TA (DFIA)
- Dampers
- Modulating damper motor(s)
- Photohelic differential pressure gauge

Figure 33. Mixing box—Building pressure control

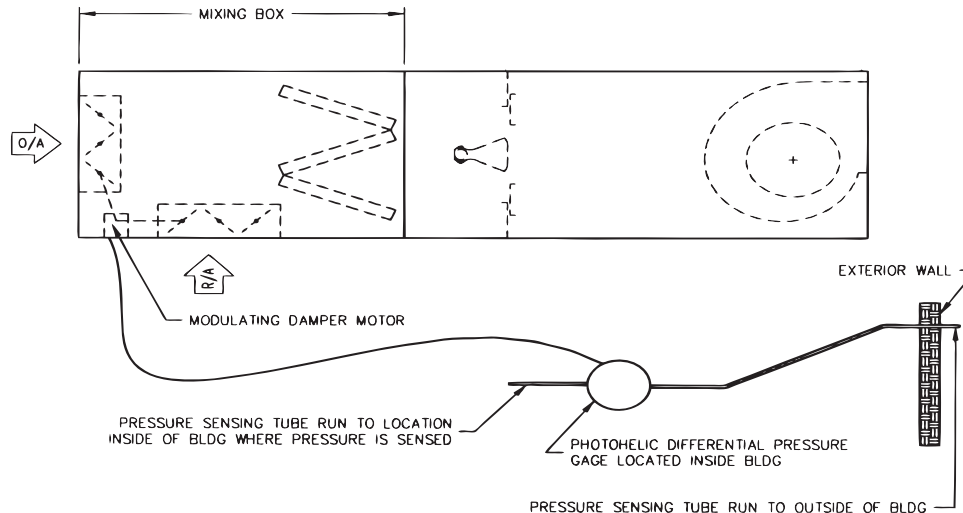

Motorized Inlet Damper

Purpose

To provide a shut-off damper.

Operation

When the fan switch is on, the inlet damper begins to open. As the inlet damper approaches the full open position, a built-in end switch located inside the damper motor closes. The closed end switch starts the fan motor. When the fan switch is turned to the "off" position, or if there is a power failure, the inlet damper closes.

Option Includes:

- Damper
- Two position damper motor(s) with built-in end switch and spring return
- Linkage

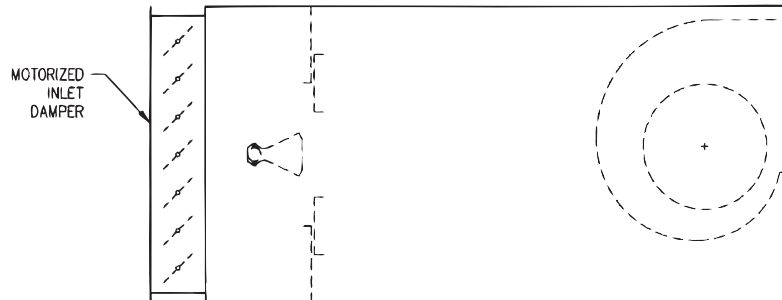
Figure 34. Motorized inlet damper

Exhaust Interlock

The exhaust interlock is a pair of contacts on the unit that will close when the unit is "on." The customer can wire the exhaust fan to the contacts so that when the heating unit is "on," the exhaust fan will also be "on." Note the heating unit turns on the exhaust fan.

The auxiliary contacts on the fan motor starter are the contacts which are used as the exhaust interlock. The auxiliary contacts are wired to the numbered terminal strip. The customer can wire the indicated terminals into the control circuit of the exhaust fan.

Note: If the customer wants the exhaust fan to turn the heating unit "on," he/she has to provide a pair of contacts that will close when the exhaust fan is "on."

Interlocking Relay

The interlocking relay is two pair of contacts, one normally open and the other normally closed. The contacts switch positions when the unit is "on." The contacts are wired to the numbered terminal strip. The customer can wire a wide range of devices to the interlocking relay by wiring to the indicated terminals.

Seven-Day Timeclock/Night Setback Thermostat

The seven-day timeclock is used primarily for either one of the following:

1. Start and stop the unit at preset times.

Example: A building is occupied at 8:00 AM. At 4:30 PM, people leave the building. The timeclock could be set to turn the unit on at 7:30 AM and off at 5:00 PM.

2. The timeclock can be used with an on-off night setback thermostat (NSB thermostat. The timeclock and NSB thermostat would be wired so that during the night, the NSB thermostat would turn the unit on and off.

Example: Same as example above, only at 5:00 PM the NSB thermostat would turn the unit on and off. If the temperature in the space fell below the setting of the NSB thermostat, the unit would come "on." If the temperature rose above the setting, the unit would go "off."

Inlet On-Off Duct Stat

Automatically turns burner off when inlet air temperature equals setting of control. Works as a lockout for the burner.

Example: If we want the burner to be “off” if the entering air temperature is 65 degrees, the inlet on-off duct stat would be set at 65 degrees.

Without the inlet on-off duct stat, if the fan switch and heat switch are both “on,” no matter how warm the incoming air, the burner will go as low as low fire, but will not go “off.”

UV Flame Sensor (UV Mini-Peeper)

Flame sensor checks to make sure the pilot flame has ignited before gas is sent to the main burner. Operates by sensing the light of the pilot flame.

If the flame sensor does not sense the pilot flame, the unit shuts down (fan and burner go off) and the flame failure light on the optional remote panel goes on.

The unit has to be reset by pushing the reset button on the burner relay.

Differences between UV Flame Sensor and Flame Rod:

Both are used for the same purpose — to check if the pilot flame is on. The flame rod is “standard.” The UV sensor needs to be ordered as an option.

If condensation forms on the flame rod while the unit is off, it may give a false signal and prevent the unit from coming on. The wet flame rod does not sense the pilot flame and shuts the unit down. This nuisance tripping can be avoided with the UV flame sensor.

Optional Gas Controls

Constant Discharge Temperature

The constant discharge temperature, gas modulating control system consists of electronic gas modulating system (40°F to 90°F range), which includes a discharge air sensor located in the blower discharge, a modulator/regulator valve mounted in the gas piping manifold, an amplifier installed in the electrical control panel, a 115 to 24 volt transformer, and a remote temperature selector.

Series 44 — Space Temperature Control

The space temperature control, gas modulating control system consists of the Maxitrol electronic gas modulating system, which includes a Series 44 discharge air sensor (55°F to 90°F range) mounted in the blower discharge, a modulator regulator valve mounted in the gas piping manifold, an amplifier installed in the electric control panel, a 115 volt to 24 volt transformer, and a Selectrastat mounted in the area where the temperature is to be sensed.

Factory Installed Options

Motors—General

All motors are provided as standard, with a starter for external overload protection, a control transformer, and an on-fused disconnect switch.

Open Drip-Proof Motor, 60 Hz/1800 Rpm

Single Phase

Optional 115V motors are available in 3/4 hp to 3 hp models. Optional 208V motors are available in 3/4 hp to 7-1/2 hp models. Optional 230V motors are available in 3/4 hp to 10 hp models. All motors have rigid base construction and ball bearings. Class A insulation is on all motors up to and including 3 hp models. Class B insulation is on 5 hp and above models.

Three-Phase

Optional 208V, 230V, 460V available in 1 hp to 60 hp models. All models have rigid base construction and ball bearings. Class B insulation is on all three-phase motors.

Options

Energy Efficient ODP 60 Hz/1800 Rp Three-Phase Only

Optional 208V motors are available in 1 hp to 30 hp models. 230V and 460V motors are available in 1 hp to 60 hp models. All motors have rigid base construction and ball bearings. Class B insulation is on all motors.

Totally Enclosed Motor, 60 Hz/1800 Rpm

Three-Phase Only

Optional 208V motors are available in 3/4 hp to 20 hp models. Optional 230V and 460V motors are available in 3/4 hp to 60 hp models. All motors have rigid base construction and ball bearings.

Energy Efficient TEFC, 60 Hz/1800 Rpm

Three-Phase Only

Optional 208V motors are available in 1 hp to 30 hp models. 230V and 460V motors are available in 1 hp to 60 hp models. All motors have rigid base construction and ball bearings. Class B insulation is on all motors.

wo-Speed/One Winding Motors, 60 Hz/1800/900 Rpm

Three-Phase Only

Optional 208V and 230V motors available on 1 hp to 20 hp models. Optional 460V motors are available on 1 hp to 50 hp models. All motors have rigid base construction and ball bearings. Class B insulation is on all motors.

Two-Speed/Two Winding Motors, 60 Hz/1800/1200 Rpm

Three-Phase Only

Optional 208V and 230V motors available on 1 hp to 20 hp models. Optional 460V motors are available on 1 hp to 50 hp models. All motors have rigid base construction and ball bearings. Class B insulation is on all motors.

Additional Options*

Inlet Hood and Birdscreen (DFOA only)

Hood constructed of 18-gauge galvanized steel. Birdscreen is 18-gauge galvanized steel with one-inch square openings.

V-Bank Filter Section

Not required when a mixing box is specified. Constructed of 18-gauge galvanized steel.

Dampers and Mixing Box

Motorized Return Air Damper

This option provides a way to recirculate air, with the return air opening downstream of the burner. This option includes return air damper, a two-position damper motor, linkage and damper switch. It is not available with two-speed motors.

Motorized 75/25 Damper

This option provides a way for recirculating return air and allows building pressure to control the amount of air that is recirculated. This option includes a return air damper, burner profile plate damper, damper linkage, and modulating pressure controller. It is not available with two-speed motors.

Mixing Box—Temperature Control

This option provides a way for recirculating return air and allows mixed air temperature to determine the amount of OA/RA. This option includes mixing box with filter section, dampers, damper actuator(s), and damper controls.

Mixing Box—Building Pressure Control

This option provides a way for recirculating return air and allows building pressure to control the amount of air which is recirculated. This option includes a mixing box with filter section, dampers, damper actuator(s), and damper controls (including a photohelic differential pressure gauge).

Mixing Box—Manual Control

This option provides a way for recirculating return air and using manual control to determine the amount of OA/RA. This option includes a mixing box with filter section, dampers, damper actuator(s), and a manual potentiometer.

Motorized Inlet Damper Option

This option provides a shutoff damper. On DFIA models, this option includes an outside air damper, damper motor with built-in end switch, and linkage. It is not available with a mixing box.

On DFOA models, this option includes an outside air damper, two-position damper motor with a built-in end switch, and linkage. It is not available with a mixing box.

Motorized Outlet Damper (DFOA)

This option provides a shut off damper and includes a discharge damper, two-position damper motor with built-in end switch, and linkage.

Note: *Based on unit design, some options can ship factory-installed or field-installed. Contact the factory for verification.*

Additional Factory Installed Options**Insulation**

One-inch, 1-1/2 lb fiberglass insulation pin spotted to casing.

Internal Blower/Motor Isolation (DFOA only)

This option includes a steel frame for blower(s) and fan motor with spring type vibration isolators. It is not available on vertical units.

Extended Grease Lines (DFOA only)

This option allows lubrication of fan bearings from the control side of the unit.

Controls Opposite from Standard

Applicable only to horizontal configurations. Locates controls, gas piping and fan motor on opposite side of the unit.

115V Duplex Receptacle

This option includes a transformer and disconnect switch for the receptacle. Components are mounted in the gas piping manifold, on DFOA units, and on the controls side of unit on DFIA models.

UV Flame Sensor

The flame sensor checks to make sure the pilot flame has ignited before gas is sent to the main burner. It operates by sensing the light of the pilot flame.

Clogged Filter Switch

This option includes a pressure sensing switch which senses the pressure drop across the filters. When the pressure drop reaches the setpoint, the switch trips and lights the clogged filter light. It is not required when City of Chicago controls are ordered.

Exhaust Fan Interlock

This option includes a pilot duty rated normally open contact on the main supply fan motor starter that will close simultaneously with the starter (10 amp contacts).

Interlocking Relay

This option is energized by an auxiliary contact on the supply fan motor starter that can be used for additional equipment that may need to run when the supply fan is running (12 amp contacts).

Painted Blower Section**Painted Burner Section****Painted Return Air Section****Painted Filter Section****Field Installed Accessories****Vibration Feet**

Rubber-in-shear vibration isolators cannot be ordered with a roof curb – they ship unmounted.

DFIA models:**Vibration Feet—Filter Section****Vibration Feet—Blower Section****Vibration Feet—Burner Section****Vibration Feet—Return Air Section****DFOA models:****Vibration Feet—Basic Frame****Vibration Feet—Filter Section****Vibration Feet—Mixing Box****Vibration Hangers (DFIA models only)**

Option includes rubber-in-shear vibration isolators, shipped unmounted.

Vibration Hangers—Blower Section**Vibration Hangers—Burner Section****Vibration Hangers—Return Air Section****Vibration Hangers—Filter Section****Seven-Day Time Clock****100 DBL Alarm Horn and Silencing Switch**

To silence the alarm, the push button silencing switch is pushed.

Remote Control Station**On-Off Night Setback Thermostat**

This option will shut unit off when space temperature is above setpoint. This is a 115V thermostat with a temperature range of 50°F to 80°F. Option is normally used together with the seven-day timeclock option.

High Gas Pressure Regulator

Specify inlet pressure at the unit. This is required for selection of the regulator.

Roof Curbs (*DFOA models only*)

Roof curbs are fabricated of 12-gauge galvanized steel. Curb gasket is provided. The 12-inch high roof curbs ship disassembled.

Roof Curb For Basic Frame — . No return air

Roof Curb For Basic Frame — . With return air downstream of the burner

Roof Curb For Basic Frame — . With mixing box option

Discharge Louver—Horizontal Vanes Adjustable Side Inlet

Discharge Louver—Horizontal Vanes, Adjustable, Top Inlet (*DFOA models only*)



Mechanical Specifications

DFIA Unit Casing

DFIA cabinets are designated for indoor use. Unit casing and accessories shall be fabricated from heavy-gauge bright spangled galvanized steel suitably reinforced to insure rigidity. All casings shall be air tight. Complete access shall be provided to all components. This includes the blower, burner, and electrical components.

DFOA Unit Casing

Unit casing and accessories shall be fabricated from heavy-gauge galvanized steel suitably reinforced to insure rigidity. The base of the unit shall be adaptable for curb mounting. All casings shall be airtight and weatherproof. Roof panels shall be convex to prevent ponding, and designed with roof eaves to prevent water from getting into wall panels. Complete access shall be provided to all components through gasketed, hinged access doors. This includes the motor, blower, burner, electrical components and manifold sections.

Fans

Supply fans are double width, double inlet centrifugal type with FC fan wheels. Fans are tested in accordance with AMCA 210.

The fan or fans are mounted on a steel shaft designed for a maximum operating speed not to exceed 75 percent of its first critical speed.

Bearings are external heavy duty industrial prelubricated type. Bearing life is 100,000 hours.

Blowers are driven by a V-belt package sized with a capacity of 25 percent greater than the motor horsepower.

Multiple belt applications will be matched sets.

Drives are adjustable pitched diameter type up through 7-1/2 hp, fixed on motors over 7-1/2 hp. DFIA motors are externally mounted on an adjustable slide base. Belt guard shall be provided for DFIA units.

Burner Section

The burner section contains a burner constructed of rust resistant cast iron bodies (which serve as the gas manifold) drilled to discharge the fuel between diverging stainless steel mixing plates.

The entire burner assembly is mounted directly in the air stream being heated. The fresh air stream passes through the mixing plates and mixes with the fuel as combustion air: thus all available heat from the gaseous fuel is released directly into the air stream. Air velocities across the burner assemblies are established by the use of profile plates.

The manifold is located outside of air stream and in DFOA models is also shielded from atmospheric conditions by means of a protective compartment with hinged access. An observation port shall be located to provide view of pilot and main flame.

Units are supplied with a wide range burner with a modulating turndown ratio of 25 to 1.

Adjustable profile plates are provided and sized to maintain the required velocity across the line burner. The operation of the burner is programmed through the flame safeguard with timed prepurge and flame sensing.

The burner assembly and gas manifold are completely prepiped and factory tested prior to shipment.

Control Enclosure

Units are provided with a control compartment. All controls mounted within this compartment are to be wired to a numbered terminal strip. All wiring is to be color coded and in accordance with NEC. A circuit diagram of the approved electrical drawing is laminated to the inside of the control cabinet door. All electrical components bear the UL label.

FM for ETL Listed Units

For installations with ETL labeled units requiring Factory Mutual (FM) insurance. The standard manifold meets FM requirements for ETL labeled units with 2475 MBh input or less. Units over 2475 MBh input will have motorized shut-off valves with visual indicator and high/low gas pressure switch.

IRI for ETL Listed Units

For installations with ETL labeled units requiring Industrial Risk Insurers (IRI) insurance. The standard manifold meets IRI requirements for all ETL labeled units

Block and Bleed Manifold

The block and bleed manifold consists of a manual main gas shutoff valve, a two motorized electric main gas shut-off valves with visual indicator and proof of closure with electrical interlock, a normally open vent valve, the Maxitrol modulating gas valve, a manual pilot gas shutoff valve, a manual pilot gas pressure regulator, a pilot gas valve, an orifice needle valve, and a high/low gas pressure switch. Can be used for installations with unlisted units requiring Industrial Risk Insurers (IRI) insurance.

Modulating Room Temperature (MRT) Control System

The Modulating Room Temperature (MRT) control system controls the space temperature and consists of setpoints for room temperature and both minimum and maximum discharge air temperature and the unit DDC Controller with full BACnet[®] compatibility, a signal conditioner, a modulator/regulator gas valve, an inlet air sensor, a discharge air sensor, and a remote control panel. The remote control panel consists of a remote mounted 3 gang box cover with a manual potentiometer to enable unit and adjust leaving air temperature setpoint, Fan On light, Burner On light, and Cool On light. The features of the DDC Controller will also include timed freeze protection, and inlet on-off ductstat.

Modulating Discharge Temperature (MDT) Control System

The Modulating Discharge Temperature (MDT) control system consists of the unit DDC Controller with full BACnet[®] compatibility, a signal conditioner, a modulator/regulator gas valve, an inlet air sensor, a discharge air sensor, and a remote control panel. The remote control panel consists of a remote mounted 3 gang box cover with a manual potentiometer to enable unit and adjust leaving air temperature setpoint, Fan On light, Burner On light, and Cool On light. The features of the DDC Controller will also include timed freeze protection, and inlet on-off ductstat.

Modulating Room Temperature Pro (MRT Pro) Control System

The Modulating Room Temperature Pro (MRT Pro) control system controls the space temperature and a unit DDC Controller with full BACnet[®] compatibility, a signal conditioner, a modulator/regulator gas valve, an inlet air sensor, a discharge air sensor, and a space temperature thermostat where room temperature can be sensed and set. In addition to allowing the user to control the room setpoint temperature the room sensor also allows over ride timing and display of current heating and cooling setpoints, fan status, and outside air temperature. The features of the DDC Controller will also include timed freeze protection and an inlet on-off ductstat.

Modulating Room Temperature Expert (MRT Expert) Control System

The Modulating Room Temperature Expert (MRT Expert) control system controls the space temperature and consists of setpoints for room temperature and both minimum and maximum discharge air temperature and the unit DDC Controller with full BACnet[®] compatibility, a signal conditioner, a modulator/regulator gas valve, an inlet air sensor, a discharge air sensor, and a space temperature sensor and a BACview[®] controller for remote keyboard display. The features of the DDC Controller will also include timed freeze protection, inlet on-off ductstat, electronic time clock with normal, holiday, and override schedules, and on-off night setback thermostat.



Mechanical Specifications

The display functions of the BACview keypad display with a minimum of four lines, sixteen characters will include the following:

Table 38. Display functions of the BAVview keypad

Display Functions:	Critical Alarm Conditions:	BACview® Control Settings:
Return air temperature	Airflow switch failure	Heating setpoint
Outside air temperature	Unit on, fan off	Cooling setpoint
Discharge air temperature	Unit off, fan on	Economizer setpoint
Mixed air temperature	Low discharge temperature	Setback setpoint
Maximum allowable temperature rise	Safety circuit open	Freeze protection setpoint
Actual temperature rise	Burner jumped	Maximum discharge air temperature setpoint
Current percent of outside air		Minimum ventilation option and setpoint
Current building pressure		Time of day schedule selection and setpoints
Current damper input voltage		
Current burner input voltage		
Fan operating hours since last reset		
Fan start cycle count since last reset		
Burner operating hours since last reset		
Burner start cycle count since last reset		
Cooling interlock operating hours since last reset		
Cooling interlock cycle count since last reset		

Gas Train Approvals

The standard gas train consists of a main manual gas shutoff valve, a motorized electric main gas valve, modulating gas valve, a manual pilot gas shutoff valve, a manual pilot gas pressure regulator, a pilot gas valve, an orificed needle valve and auxiliary gas valve.

The Factory Mutual (FM) gas train consists of a manual main gas shutoff valve, a motorized electric main gas valve, modulating gas valve, a manual pilot gas shut-off valve, a manual pilot gas pressure regulator, a pilot gas valve, an orificed needle valve, a high/low gas pressure switch, a manual auxiliary gas shutoff valve, and an auxiliary gas valve. *(Optional)*

Note: *The standard gas train meets FM requirements for inputs under 2500 MBh for ETL listed units.*

The Industrial Risk Insurers (IRI) gas train consists of a manual main gas shutoff valve, a motorized electric main gas valve, modulating gas valve, a manual pilot gas shutoff valve, a manual pilot gas pressure regulator, a pilot gas valve, an orificed needle valve, a high/low gas pressure switch, a manual auxiliary gas shutoff valve, a normally open vent valve, and an auxiliary gas valve. *(Optional)*

Note: *The standard gas train meets IRI requirements for ETL listed units.*



www.trane.com

For more information, contact your local Trane office or e-mail us at comfort@trane.com

Literature Order Number	MUA-PRC007-EN
Date	November 2009
Supersedes	MUA-PRC007-EN (March 2007)

Trane has a policy of continuous product and product data improvement and reserves the right to change design and specifications without notice. Only qualified technicians should perform the installation and servicing of equipment referred to in this literature.