



# Installation, Operation, and Maintenance

## Gas Unit Heater

Separated Combustion Indoor Gas-Fired Duct Furnace



### **⚠ SAFETY WARNING**

Only qualified personnel should install and service the equipment. The installation, starting up, and servicing of heating, ventilating, and air-conditioning equipment can be hazardous and requires specific knowledge and training. Improperly installed, adjusted or altered equipment by an unqualified person could result in death or serious injury. When working on the equipment, observe all precautions in the literature and on the tags, stickers, and labels that are attached to the equipment.



# Warnings, Cautions and Notices

**Warnings, Cautions and Notices.** Note that warnings, cautions and notices appear at appropriate intervals throughout this manual. Warnings are provide to alert installing contractors to potential hazards that could result in death or personal injury. Cautions are designed to alert personnel to hazardous situations that could result in personal injury, while notices indicate a situation that could result in equipment or property-damage-only accidents.

Your personal safety and the proper operation of this machine depend upon the strict observance of these precautions.

Read this manual thoroughly before operating or servicing this unit.

**ATTENTION:** Warnings, Cautions and Notices appear at appropriate sections throughout this literature. Read these carefully:

**WARNING** Indicates a potentially hazardous situation which, if not avoided, could result in death or serious injury.

**CAUTION** Indicates a potentially hazardous situation which, if not avoided, could result in minor or moderate injury. It could also be used to alert against unsafe practices.

**NOTICE:** Indicates a situation that could result in equipment or property-damage only

## Important Environmental Concerns!

Scientific research has shown that certain man-made chemicals can affect the earth's naturally occurring stratospheric ozone layer when released to the atmosphere. In particular, several of the identified chemicals that may affect the ozone layer are refrigerants that contain Chlorine, Fluorine and Carbon (CFCs) and those containing Hydrogen, Chlorine, Fluorine and Carbon (HCFCs). Not all refrigerants containing these compounds have the same potential impact to the environment. Trane advocates the responsible handling of all refrigerants-including industry replacements for CFCs such as HCFCs and HFCs.

## Responsible Refrigerant Practices!

Trane believes that responsible refrigerant practices are important to the environment, our customers, and the air conditioning industry. All technicians who handle refrigerants must be certified. The Federal Clean Air Act (Section 608) sets forth the requirements for handling, reclaiming, recovering and recycling of certain refrigerants and the equipment that is used in these service procedures. In addition, some states or municipalities may have additional requirements that

must also be adhered to for responsible management of refrigerants. Know the applicable laws and follow them.

**WARNING**

**Proper Field Wiring and Grounding Required!**

All field wiring **MUST** be performed by qualified personnel. Improperly installed and grounded field wiring poses **FIRE** and **ELECTROCUTION** hazards. To avoid these hazards, you **MUST** follow requirements for field wiring installation and grounding as described in **NEC** and your local/state electrical codes. Failure to follow code could result in death or serious injury.

**WARNING**

**Personal Protective Equipment (PPE) Required!**

Installing/servicing this unit could result in exposure to electrical, mechanical and chemical hazards.

- Before installing/servicing this unit, technicians **MUST** put on all Personal Protective Equipment (PPE) recommended for the work being undertaken. **ALWAYS** refer to appropriate MSDS sheets and OSHA guidelines for proper PPE.
- When working with or around hazardous chemicals, **ALWAYS** refer to the appropriate MSDS sheets and OSHA guidelines for information on allowable personal exposure levels, proper respiratory protection and handling recommendations.
- If there is a risk of arc or flash, technicians **MUST** put on all Personal Protective Equipment (PPE) in accordance with **NFPA 70E** or other country-specific requirements for arc flash protection, **PRIOR** to servicing the unit.

Failure to follow recommendations could result in death or serious injury.

**ATTENTION:** READ THIS MANUAL AND ALL LABELS ATTACHED TO THE UNIT CAREFULLY BEFORE ATTEMPTING TO INSTALL, OPERATE OR SERVICE THESE UNITS! CHECK UNIT DATA PLATE FOR TYPE OF GAS AND ELECTRICAL SPECIFICATIONS AND MAKE CERTAIN THAT THESE AGREE WITH THOSE AT POINT OF INSTALLATION. RECORD THE UNIT MODEL AND SERIAL No.(s) IN THE SPACE PROVIDED. RETAIN FOR FUTURE REFERENCE.

**⚠ WARNING****Hazardous Service Procedures!**

The maintenance and troubleshooting procedures recommended in this manual could result in exposure to electrical, mechanical or other potential safety hazards. Always refer to the safety warnings provided throughout this manual concerning these procedures. When possible, disconnect all electrical power including remote disconnect and discharge all energy storing devices such as capacitors before servicing. Follow proper lockout/tagout procedures to ensure the power can not be inadvertently energized. When necessary to work with live electrical components, have a qualified licensed electrician or other individual who has been trained in handling live electrical components perform these tasks. Failure to follow all of the recommended safety warnings provided, could result in death or serious injury.

**⚠ WARNING****Overheating or Flooding Could Cause Fire or Explosion!**

Overheating or flooding (where any part of the duct furnace has been under water) could result in fire or explosion. Should overheating occur, or the gas supply fails to shut off, shut off the manual gas valve to the duct furnace before shutting off the electrical supply. Do not use the duct furnace if any part has been under water. Immediately call a qualified service technician to inspect the duct furnace and replace any gas control which has been underwater. Failure to follow these recommendations could result in death or serious injury.

**⚠ WARNING****Hazardous Gases and Flammable Vapors!**

Exposure to hazardous gases from fuel substances have been shown to cause cancer, birth defects or other reproductive harm. Improper installation, adjustment, alteration, service or use of this product could cause flammable mixtures. To avoid hazardous gases and flammable vapors follow proper installation and set up of this product and all warnings as provided in this manual. Failure to follow all instructions could result in death or serious injury.

**Trademarks**

Trane and the Trane logo are trademarks of Trane in the United States and other countries. All trademarks referenced in this document are the trademarks of their respective owners.

3M is a trademark of 3M Company; Dow Corning is a registered trademark of Dow Corning Corporation.



# Introduction

## ⚠ WARNING

### Safety Alert!

You **MUST** follow all recommendations below. Failure to do so could result in death or serious injury.

### For Your Safety

**The use and storage of gasoline or other flammable vapors and liquids in open containers in the vicinity of this appliance is hazardous.**

**If you smell gas:**

- 1. Open windows.**
- 2. Do not touch electrical switches.**
- 3. Extinguish any open flame.**
- 4. Immediately call your gas supplier from a neighbor's phone. Follow the gas supplier's instructions.**

### Approved For Use in California

## ⚠ WARNING

### Toxic Hazard!

**Install, operate and maintain unit in accordance with manufacturer's instructions to avoid exposure to fuel substances or substances from incomplete combustion which could result in death or serious illness. The state of California has determined that these substances may cause cancer, birth defects, or other reproductive harm.**

### Installer's Responsibility

Installer Please Note: This equipment has been test fired and inspected. It has been shipped free from defects from our factory. However, during shipment and installation, problems such as loose wires, leaks, or loose fasteners may occur. It is the installer's responsibility to inspect and correct any problems that may be found.

### Receiving Instructions

Inspect shipment immediately when received to determine if any damage has occurred to the unit during shipment. After the unit has been uncrated, check for any visible damage to the unit. If any damage is found, the consignee should sign the bill of lading indicating such damage and immediately file claim for damage with the transportation company.

**Important:** *It is the equipment owner's responsibility to provide any scaffolding or other apparatus required to perform emergency service or annual/periodic maintenance to this equipment.*



# Table of Contents

Warnings, Cautions and Notices .....	2	Wiring Diagrams .....	39
Model Number Descriptions .....	6		
Indoor Gas Heating Units .....	6		
Horizontal Blower Assembly .....	6		
General Information .....	7		
Description .....	7		
General Safety Information .....	7		
Identification of Parts .....	8		
Unit Dimensions and Weights .....	10		
Installation: Mechanical .....	12		
Clearances .....	12		
Air Flow .....	13		
Suspension .....	14		
Nozzle Assembly .....	14		
Installation: Piping .....	16		
Gas Piping .....	16		
Pipe Sizing .....	16		
Pipe Installation .....	17		
Installation: Venting .....	18		
Combustion Air Venting and Piping ....	18		
Exhaust Venting .....	19		
Installation: Concentric Vent Terminal ...	21		
Horizontal Termination .....	21		
Vertical Termination .....	22		
Installation: Electrical .....	24		
Electrical Connections .....	24		
Thermostat Wiring and Location .....	24		
Start-Up .....	26		
Operation .....	26		
Gas Equipment Start-Up .....	30		
Maintenance .....	31		
Periodic Service .....	31		
Installation Instructions for Field Replace- ment of Power Venter Motor .....	33		
How to Order Replacement Parts .....	34		
Diagnostics .....	35		
Troubleshooting .....	35		



# Model Number Descriptions

## Indoor Gas Heating Units

**Note:** All units are AGA approved. For CGA approved units, contact Air Handling Product Support.

### Digit 1 – Gas Heating Equipment

G = Gas Heating Equipment

### Digit 2 – Product Type

M = Separated Combustion Indoor Duct Furnace

### Digit 3 – Fuel

N = Natural Gas  
P = LP Gas (Propane)

### Digit 4 – Development Sequence

D = Fourth Generation

### Digits 5, 6, 7 – Input Capacity Single Furnace

010 = 100 MBh    022 = 225 MBh  
012 = 125 MBh    025 = 250 MBh  
015 = 150 MBh    030 = 300 MBh  
017 = 175 MBh    035 = 350 MBh  
020 = 200 MBh    040 = 400 MBh

### Digit 8 – Main Power Supply

A = 115/60/1    D = 230/60/3  
B = 230/60/1    E = 460/60/3  
C = 208/60/3    F = 575/60/3

### Digit 9 – Gas Control Option

D = Single-Stage, Intermittent Pilot Ignition  
E = Two-Stage, Intermittent Pilot Ignition  
H = Electronic Modulating with Room T-Stat, Intermittent Pilot Ignition  
J = Electronic Modulating with Duct-Stat, Intermittent Pilot Ignition  
L = Electronic Modulating with External 4–20 mA Input  
N = Electronic Modulating with External 0–10 Vdc Input  
T = Single Stage Direct Spark Ignition  
V = Two-Stage, Direct Spark Ignition

### Digit 10 – Design Sequence

G = Seventh Design

### Digit 11 – Heat Exchanger Material

1 = Aluminized Steel  
3 = #321 Stainless Steel

### Digit 12 – Rooftop Arrangements

0 = None (Indoor Unit)

### Digit 13 – Rooftop Heating Unit Motor Selection

0 = None (Indoor Unit and Rooftop Duct Furnace)

### Digit 14 – Rooftop Fan Section

0 = None (Indoor Unit and Rooftop Duct Furnace)

### Digit 15 – Miscellaneous Options

0 = None  
A = #409 Stainless Steel Burners  
B = Orifices For Elevation Above 2000 Feet (Specify Elevation)  
C = #409 Stainless Steel Draft Diverter  
D = Summer-Winter Switch  
F = Horizontal Louvers  
G = Horizontal and Vertical Louvers

## Horizontal Blower Assembly

### Digit 1, 2, 3 – Horizontal Blower Assembly

### Digit 4 – Development Sequence

C = Third Generation

### Digit 5, 6 – Blower Size

15 = Nominal 1500 cfm  
20 = Nominal 2000 cfm  
30 = Nominal 3000 cfm  
45 = Nominal 4500 cfm

### Digit 7 – Transition Size (Specifies Duct Furnace Size)

0 = None  
A = 100 MBh    F = 225 MBh  
B = 125 MBh    G = 250 MBh  
C = 150 MBh    H = 300 MBh  
D = 175 MBh    J = 350 MBh  
E = 200 MBh    K = 400 MBh

### Digit 8 – Main Power Supply

A = 115/60/1    D = 230/60/3  
B = 230/60/1    E = 460/60/3  
C = 208/60/3

### Digit 9 – Motor Horsepower

A = 1/3 hp    D = 1 hp  
B = 1/2 hp    E = 1-1/2 hp  
C = 3/4 hp    F = 2 hp

### Digit 10 – Design Sequence

D = Fourth Design

### Digit 11 – Miscellaneous Options

0 = None  
1 = Insulation  
3 = Totally Enclosed Motor

# General Information

## Description

The duct furnace design is certified by ETL for use with natural and LP (propane) gases. ANSI and NFPA Standards as well as Canadian installation codes referred to in this manual are the ones that were applicable at the time that the design was certified. In addition, the duct furnace may be installed on the downstream side of a cooling coil, without need of a bypass duct.

If the unit is to be installed at an altitude exceeding 2,000 feet (610 m) above sea level, derate the input by 4 percent for each 1,000 foot (305 m) rise above sea level. Special orifices are required for installations above 2,000 feet (610 m).

When units are installed in Canada, any reference to derations at altitudes in excess of 2000 feet (610 m) are to be ignored. At altitudes of 2000 to 4500 feet (610 to 1372 m), the units must be orificed to 90 percent of the normal altitude rating, and be so marked in accordance with the ETL certification.

## General Safety Information

**Important:** *This product must be installed by a licensed plumber or gas fitter when installed within the Commonwealth of Massachusetts.*

### **WARNING**

#### **Safety Alert!**

You **MUST** follow all recommendations below. Failure to do so could result in death or serious injury.

- **Installation must be made in accordance with local codes, or in absence of local codes with the latest edition of ANSI Standard Z223.1 (N.F.P.A. No. 54) National Fuel Gas Code.**

**All of the ANSI and NFPA Standards referred to in these installation instructions are those that were applicable at the time the design of this appliance was certified. The ANSI Standards are available from the American National Standards Institute, INC., 11 West 42nd Street, New York, NY., 10036 or [www.ansi.org](http://www.ansi.org). The NFPA Standards are available from the National Fire Protection Association, Batterymarch Park, Quincy, MA 02269. These duct furnaces are designed for use in airplane hangars when installed in accordance with current ANSI/NFPA No. 409 and in public garages when installed in accordance with current NFPA No. 88A and NFPA No. 88B.**

**If installed in Canada, the installation must conform with local building codes, or in absence of local building codes, with CGA-B149.1 "Installation Codes for Natural Gas Burning**

**Appliances and Equipment" or CGA-B149.2 "Installation Codes for Propane Gas Burning Appliances and Equipment": These duct furnaces have been designed and certified to comply with CGA 2.6. Also see sections on installation in "Aircraft Hangers," p. 12 and "Public Garages," p. 12.**

- **Do not alter the duct furnace in any way or damage to the unit and/or severe personal injury or death could occur!**
- **Turn off the gas supply and disconnect all electric power, including remote disconnects before servicing unit. Follow proper lockout/tagout procedures to ensure the power can not be inadvertently energized and the gas can not be inadvertently turned on. Failure to turn off gas or disconnect power before servicing could result in death or serious injury.**
- **Follow installation instructions CAREFULLY to avoid creating unsafe conditions. All wiring should be done and checked by a qualified electrician, using copper wire only. All external wiring must conform to applicable local codes and to the latest edition of the National Electrical Code ANSI/NFPA No. 70.**
- **All gas connections should be made and leak-tested by a suitably qualified individual, per instructions in this manual. Also follow procedures listed in "Gas Equipment Start-Up," p. 30.**
- **Use only the fuel for which the duct furnace is designed (see rating plate). Using LP gas in a heater that requires natural gas, or vice versa, will create the risk of gas leaks, carbon monoxide poisoning and explosion.**

**Important:** *Do not attempt to convert the furnace for use with a fuel other than the one intended. Such conversion is dangerous, as it could create the risks listed previously.*

- **Make certain that the power source conforms to the electrical requirements of the furnace.**
- **All field-installed wiring must be completed by qualified personnel. All field-installed wiring must comply with NEC and applicable local codes. Failure to follow this instruction could result in death or serious injuries.**
- **Special attention must be given to any grounding information pertaining to this duct furnace. To prevent the risk of electrocution, the furnace must be securely and adequately grounded. This should be accomplished by connecting a grounded conductor between the service panel and the furnace. To ensure a proper**



## General Information

ground, the grounding means must be tested by a qualified electrician.

- **Do not insert fingers or foreign objects into the furnace or its air moving device. Do not block or tamper with the heater in any manner while in operation or just after it has been turned off, as some parts may be hot enough to cause injury.**
- **This furnace is intended for general heating applications ONLY. It must NOT be used in potentially dangerous locations such as flammable, explosive, chemical-laden or wet atmospheres.**
- **In cases in which property damage may result from malfunction of the furnace, a backup system or a temperature sensitive alarm should be used.**
- **When connecting to existing gas lines be sure to valve off the gas supply ahead of connection point. To avoid explosion or possible fire, always purge all residual gas from piping before cutting into existing line or removing threaded fittings. Failure to remove all gas vapors could result in death or serious injury or equipment or property-only-damage.**

Unless otherwise specified, the following conversions may be used for calculating SI unit measurements:

1 foot = 0.305 m	1 inch water column = 0.249 kPa
1 inch = 25.4 mm	1 meter/second = FPM ÷ 196.8
1 psig = 6.894 kPa	1 liter/second = CFM x 0.472
1 pound = 0.453 kg	1000 Btu per hour = 0.293 kW
1 gallon = 3.785 L	1000 Btu/Cu. Ft. = 37.5 MJ/m <sup>3</sup>
	1 cubic foot = 0.028 m <sup>3</sup>

## Identification of Parts

Figure 1. Combustion chamber

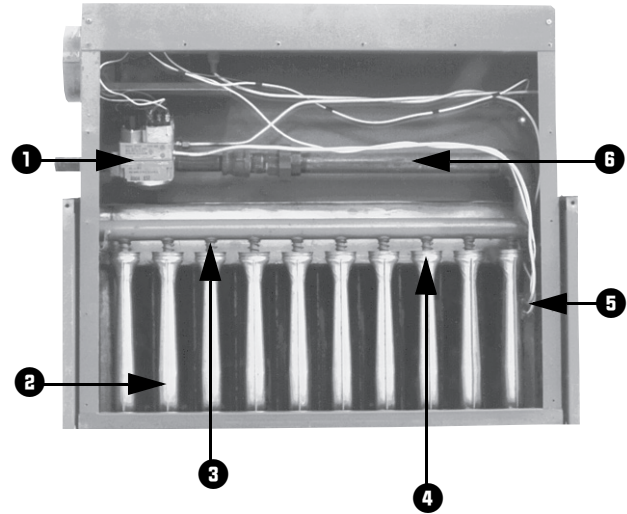

- |                    |                 |
|--------------------|-----------------|
| 1. Gas valve       | 4. Air shutters |
| 2. Main burners    | 5. Pilot assy.  |
| 3. Retainer spring | 6. Manifold     |



**Figure 2. Internal furnace assembly**

MANIFOLD & MAIN BURNERS  
INCLUDED IN BURNER  
COMPARTMENT ASS'Y.

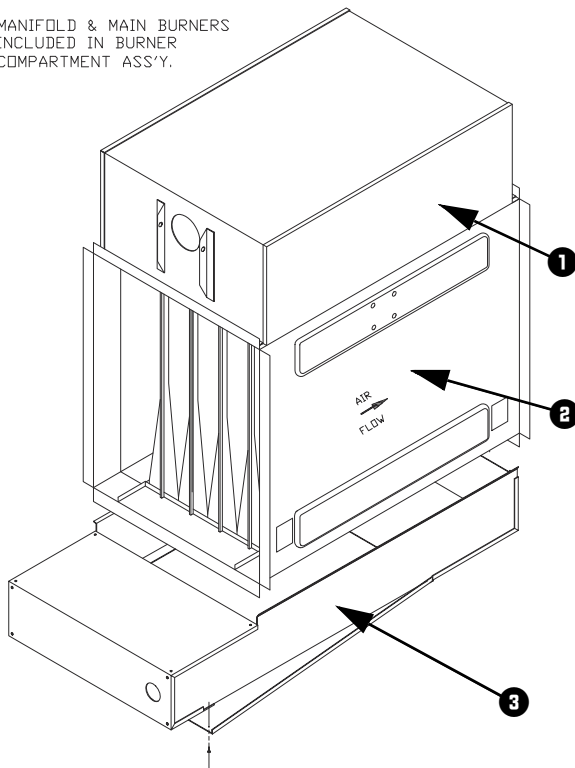

1. Flue Collector
2. Heat Exchanger
3. Burner Drawer

# Unit Dimensions and Weights

**Table 1. Specification data: Separated Combustion Duct Furnace**

Unit Size	A in. (mm)	B in. (mm)	C in. (mm)	D (Dia.) <sup>(a)</sup> in. (mm)	Gas Inlet in.		Weight lb (kg)
					Nat.	LP	
100	17-7/8 (454)	15-1/2 (394)	17-1/8 (435)	4 (102)	1/2	1/2	161 (73)
125	20-5/8 (524)	18-1/4 (464)	19-7/8 (505)	4 (102)	1/2	1/2	180 (82)
150	20-5/8 (524)	18-1/4 (464)	19-7/8 (505)	4 (102)	1/2	1/2	188 (85)
175	23-3/8 (594)	21 (533)	22-5/8 (575)	4 (102)	1/2	1/2	207 (93)
200	26-1/8 (664)	23-3/4 (603)	25-3/8 (645)	5 (127)	1/2	1/2	227 (103)
225	28-7/8 (733)	26-1/2 (673)	28-1/8 (714)	5 (127)	3/4	1/2 or 3/4	246 (116)
250	31-5/8 (803)	29-1/4 (743)	30-7/8 (784)	5 (127)	3/4	1/2 or 3/4	266 (121)
300	37-1/8 (943)	34-3/4 (883)	36-3/8 (924)	6 (152)	3/4	1/2 or 3/4	305 (138)
350	42-5/8 (1083)	40-1/4 (1022)	41-7/8 (1064)	6 (152)	3/4	1/2 or 3/4	344 (156)
400	48-1/8 (1222)	45-3/4 (1162)	47-3/8 (1203)	6 (152)	3/4	1/2 or 3/4	383 (174)

(a) "D" dia. equals the air inlet opening and the flue discharge opening.

**Figure 3. Dimensions, standard units**

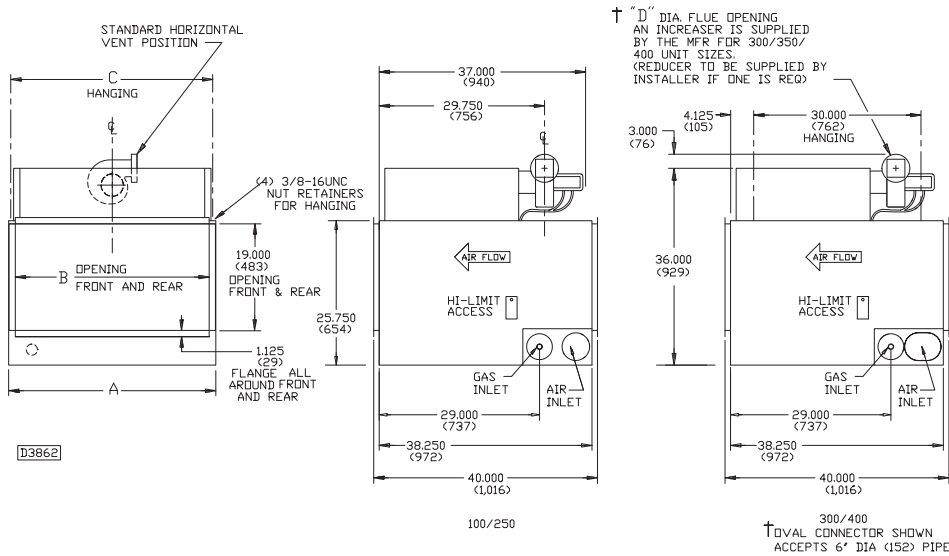
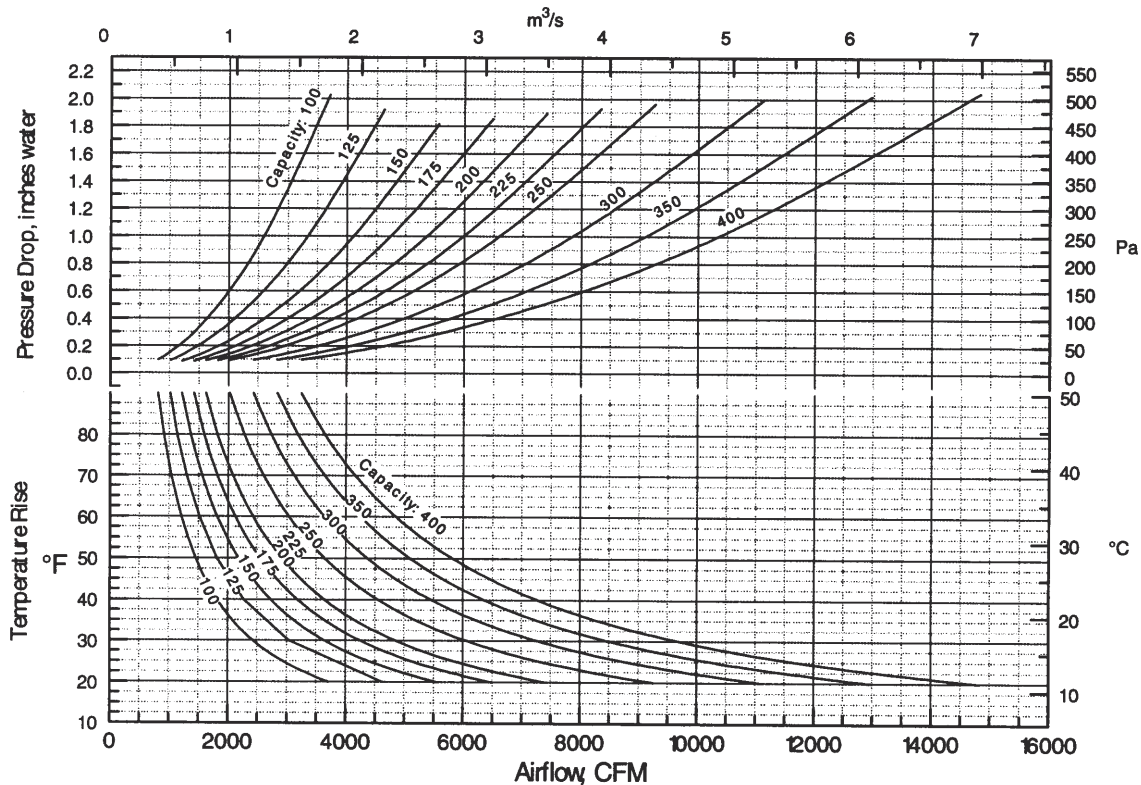

**Table 2. Performance data**

Unit Size	Input		Output MBh (kW)	MIN cfm (m <sup>3</sup> /s)	Temp. Rise °F (°C)	P.D. in. of H <sub>2</sub> O (kPa)	MAX cfm (m <sup>3</sup> /s)	Temp. Rise °F (°C)	P.D. in. of H <sub>2</sub> O (kPa)
	MAX MBh (kW)	MIN MBh (kW)							
	MBh (kW)	MBh (kW)							
100	100 (29.3)	50 (14.6)	80 (23.4)	822 (0.388)	90 (50)	0.10 (0.02)	3,700 (1,746)	20 (11)	2.03 (0.51)
125	125 (36.6)	62.5 (18.3)	100 (29.3)	1,028 (0.485)	90 (50)	0.09 (0.02)	4,625 (2,183)	20 (11)	1.92 (0.48)
150	150 (43.9)	75 (22.0)	120 (35.1)	1,233 (0.582)	90 (50)	0.09 (0.02)	5,550 (2,620)	20 (11)	1.81 (0.45)
175	175 (51.2)	87.5 (25.6)	140 (41.0)	1,439 (0.679)	90 (50)	0.09 (0.02)	6,475 (3,056)	20 (11)	1.86 (0.46)
200	200 (58.6)	100 (29.3)	160 (46.9)	1,645 (0.776)	90 (50)	0.09 (0.02)	7,401 (3,493)	20 (11)	1.90 (0.47)
225	225 (65.9)	112.5 (32.9)	180 (52.7)	1,850 (0.873)	90 (50)	0.09 (0.02)	8,326 (3,930)	20 (11)	1.93 (0.48)
250	250 (73.2)	125 (36.6)	200 (58.6)	2,056 (0.970)	90 (50)	0.09 (0.02)	9,251 (4,366)	20 (11)	1.96 (0.49)
300	300 (87.8)	150 (43.9)	240 (70.3)	2,467 (1.164)	90 (50)	0.10 (0.02)	11,101 (5,240)	20 (11)	2.00 (0.50)
350	350 (102.5)	175 (51.2)	280 (82.0)	2,878 (1.358)	90 (50)	0.10 (0.02)	12,951 (6,113)	20 (11)	2.02 (0.50)
400	400 (117.1)	200 (58.6)	320 (93.7)	3,289 (1.552)	90 (50)	0.10 (0.02)	14,801 (6,986)	20 (11)	2.05 (0.51)

**Note:** Ratings are shown for elevations up to 2,000 feet (610 m) above sea level. Above 2,000 feet (610 m), input must be derated 4 percent for each 1,000 feet (305 m) above sea level. When units are installed in Canada, any reference to derations at altitudes in excess of 2,000 feet (610 m) are to be ignored. At altitudes of 2,000 to 4,500 feet (610 to 1,372 m), the units must be orificed to 90 percent of the normal altitude rating, and be so marked in accordance with the ETL certification.

**Figure 4. Temperature rise and pressure drop graph**





# Installation: Mechanical

## NOTICE:

### Equipment Damage!

Do not install duct furnaces in corrosive or flammable atmospheres! Premature failure of, or severe damage to the unit could result! Avoid locations where extreme drafts can affect burner operation. Duct furnaces must not be installed in locations where air for combustion would contain chlorinated, halogenated or acidic vapors. If located in such an environment, premature failure of the unit could occur!

**Note:** Furnace sizing should be based on heat loss calculations where the furnace output equals or exceeds heat loss.

**Aircraft Hangars.** Separated Combustion must be installed in aircraft hangars as follows: in aircraft hangars, duct furnaces must be at least 10 feet (3.0 m) above the upper surface of wings or engine enclosures of the highest aircraft to be stored in the hangar, and 8 feet (2.4 m) above the floor in shops, offices and other sections of the hangar where aircraft are not stored or housed. In Canada, installation is suitable in aircraft hangars when acceptable to the enforcing authorities.

**Public Garages.** In repair garages, duct furnaces must be installed in a detached building or room separate from repair areas as specified in the latest edition of NFPA 88B, Repair Garages.

In parking structures, duct furnaces must be installed so that the burner flames are located a minimum of 18 inches (457 mm) above the floor or protected by a partition not less than 18 inches (457 mm) high. Refer to the latest edition of NFPA 88A, Parking Structures.

In Canada, installation must be in accordance with the latest edition of CGA B149 "Installation Codes for Gas Burning Appliances and Equipment."

## NOTICE:

### Maintain Minimum Thermostat Setting!

Separated Combustion Duct Furnaces should not be installed to maintain low temperatures and/or freeze protection of buildings. A minimum of 50°F (10°C) thermostat setting must be maintained. If duct furnaces are operated to maintain lower than 50°F (10°C), hot flue gases are cooled inside the heat exchanger to a point where water condenses onto the heat exchanger walls. The result is a mildly corrosive acid that prematurely corrodes the aluminized heat exchanger and can actually drip water down from the duct furnace onto the floor surface. Additional duct furnaces should be installed if a minimum 50°F (10°C) thermostat setting cannot be maintained. Failure to follow these recommendations could result in equipment or property damage.

## ⚠ WARNING

### Overheating or Flooding Could Cause Fire or Explosion!

Overheating or flooding (where any part of the duct furnace has been under water) could result in fire or explosion. Should overheating occur, or the gas supply fails to shut off, shut off the manual gas valve to the duct furnace before shutting off the electrical supply. Do not use the duct furnace if any part has been under water. Immediately call a qualified service technician to inspect the duct furnace and replace any gas control which has been underwater. Failure to follow these recommendations could result in death or serious injury.

## ⚠ WARNING

### Hazardous Gases and Flammable Vapors!

Exposure to hazardous gases from fuel substances have been shown to cause cancer, birth defects or other reproductive harm. Improper installation, adjustment, alteration, service or use of this product could cause flammable mixtures. To avoid hazardous gases and flammable vapors follow proper installation and set up of this product and all warnings as provided in this manual. Failure to follow all instructions could result in death or serious injury.

## Clearances

**Note:** Increasing the clearance distances may be necessary if there is a possibility of distortion or discoloration of adjacent materials.

## ⚠ WARNING

### Combustible Materials!

Maintain proper clearance between the unit heat exchanger, vent surfaces, and combustible materials. Refer to unit nameplate and installation instructions for proper clearances. Improper clearances could result in a fire hazard. Failure to maintain proper clearances could result in death or serious injury or property damage.

Maintain adequate clearances around air openings into combustion chamber:

Table 3. Minimum clearances

Sides	18" (457 mm)
Top	6" (152 mm)
Bottom	25" (635 mm)
Flue	6" (152 mm)

**Note:** When the clearances required for accessibility are greater than the minimum required safety clearances, the accessibility clearances take precedence.

Increasing the clearance distances may be necessary if there is a possibility of distortion or discoloration of adjacent materials.

### Accessibility

The Separated Combustion Duct Furnace is a bottom service access type. Allow a minimum of 25 inches (635 mm) at the bottom of the unit to facilitate servicing the burners and pilot. Provision should also be made to assure accessibility for recurrent maintenance purposes.

Atmospheres containing commercial solvents or chlorinated hydrocarbons will produce corrosive acids when coming in contact with the flames. This will greatly reduce the life of the gas duct furnace and may void the warranty. Avoid such areas.

### **⚠ WARNING**

#### **Fire Hazard!**

**If the gas duct furnace is to be used in a building classified as having a hazardous atmosphere, the installation must comply with the standards set by the National Board of Fire Underwriters. Consult the authorities having jurisdiction before starting the job. Failure to follow recommendations could result in death or serious injury.**

The Separated Combustion Duct Furnace must be installed on the positive pressure side of the air circulation blower.

### Ductwork

Properly designed and installed ductwork, providing a uniformly distributed flow of air across the surfaces of the heat exchanger, is essential to satisfactory unit performance and life of the equipment.

All duct connection flanges/seams must be sealed to prevent air leaks. Sealant/tape must be suitable for temperatures 250°F (121°C) minimum.

### **NOTICE:**

#### **Use 90° Duct Connection Flanges!**

**Ducts must be properly connected to duct furnaces for operation. Do not straighten the 90° duct connection flanges on the duct furnaces. Straightening the 90° duct connection flanges will affect the operation of the furnace and will void the warranty.**

If uniform air distribution is not obtained, install additional baffles and/or turning vanes in the ductwork.

Figure 5 and Figure 6 illustrate recommended ductwork designs for both the straight-through and elbowed air inlet arrangements.

**Figure 5. Recommended design for field installation of ductwork for straight-through arrangement**

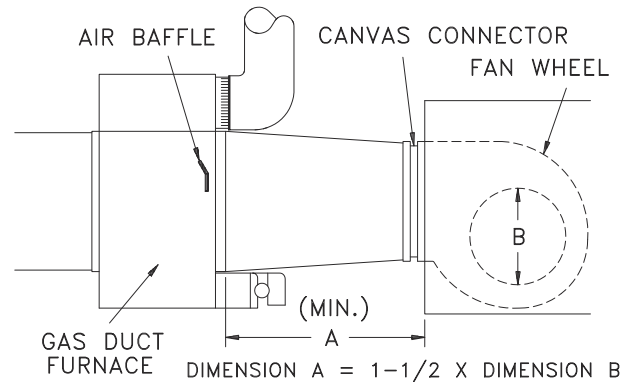

**Figure 6. Recommended ductwork design for elbowed arrangement**

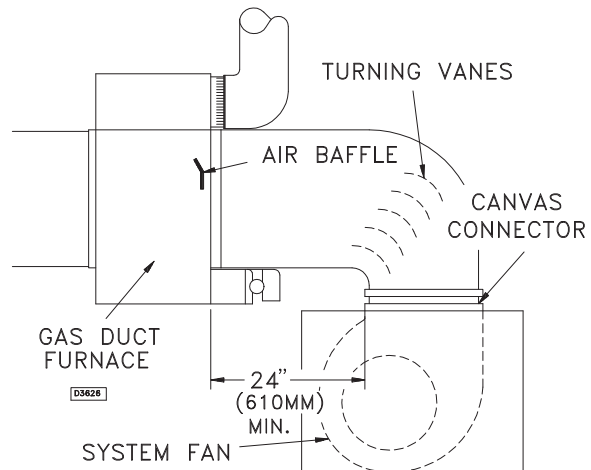

Access panels large enough to observe smoke and reflected light, and to detect the presence of leaks in the heating equipment, are required both upstream and downstream from gas duct furnaces. These panels must be sealed to prevent air leaks. If allowed by local regulations, install canvas connectors between the ductwork and fan discharge opening to eliminate the transmission of sound.

### Air Flow

The installation is to be adjusted to obtain an air throughput within the range specified on the appliance rating plate.

### Bypass

When a gas duct furnace is installed to operate in conjunction with a summer air conditioning system, the cfm air delivery of the system blower should be adjusted to meet the design air volume requirements for cooling. If this cfm delivery is greater than that required for heating, resulting in a low air temperature rise, install a damper

bypass around the gas duct furnace to bypass a portion of the air.

## Suspension

### ⚠ WARNING

#### Heavy Objects!

Ensure that all hardware used in the suspension of each duct furnace is capable of supporting the unit weight. Failure to do so could result in unit falling off its mounting location, which could result in death or serious injury.

### NOTICE:

#### Equipment Damage!

The Separated Combustion Duct Furnace must be hung level from side to side and front to back, from four suspension points provided at the top of the unit. Failure to do so could result in poor performance and/or premature failure of the unit. Refer to [Figure 7, p. 14](#) for typical suspension arrangements.

### ⚠ WARNING

#### Heavy Objects!

Make certain that the lifting methods used to lift the duct furnace and the method of suspension used in the field installation of the duct furnace are capable of uniformly supporting the weight of the furnace at all times. Make certain that the structure to which the furnace is mounted is capable of supporting its weight. Under no circumstances must the heater gas lines, the venting system or the electrical conduit be used for support. Failure to follow recommendations could result in death, serious injury, or property damage.

## Nozzle Assembly

**Figure 7. Typical four (4) point duct suspending arrangement**

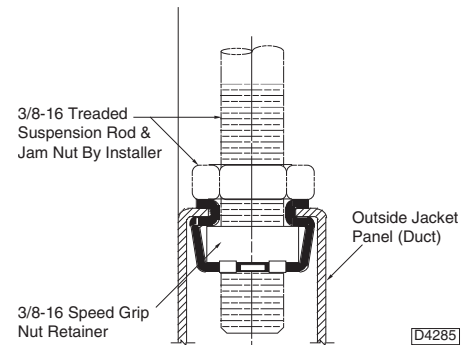
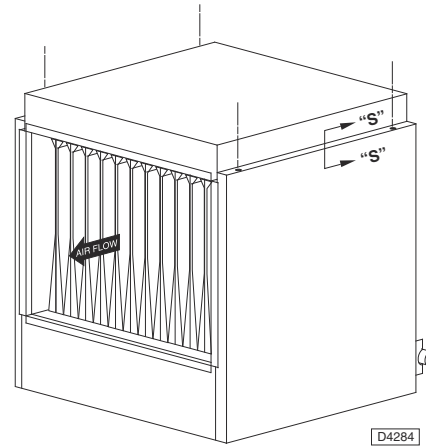

Use the following procedure for assembling the 30-, 60-, or 90-degree nozzle assembly to your unit heater.

1. Remove the louvers and the cone springs from the unit heater.
2. Remove the four (4) screws from the upper section of the front of the unit heater and use these same screws to temporarily attach the top bracket (P/N 252-07948-00X).
  - a. Using the holes in the top bracket as a guide, pre-drill a 1/8" (0.125") hole at each location across the front panel of the unit heater.
  - b. Using the enclosed screws, permanently attach the top bracket.
3. Remove the upper two (2) screws from the lower section on the front of the unit heater. Repeat the procedure described in [Step 2](#) using the bottom bracket (P/N 252-07949-00X).
4. Using the sixteen (16) 5/16-12 x 1/2 screws, attach the left and right side panel (P/N 251-07944 and 251-07946) to the unit heater using the holes to which the louvers were attached.
5. Using the enclosed #8-18 x 1/2 screws and with the top panel oriented such that the side with the larger holes

is facing the unit heater, attach the top panel (P/N 251-07942-00X) to the top bracket and the two (2) side panels.

**Note:** The top panel must be attached so that the side with the larger holes is facing the unit heater; this is a requirement for later steps in this installation procedure.

- Using the enclosed #8-18 x 1/2 screws and with the bottom panel oriented such that the side with the larger holes is facing the unit heater, attach the bottom panel (P/N 251-07943-00X) to the bottom bracket and the two (2) side panels.

**Note:** The bottom panel must be attached so that the side with the larger holes is facing the unit heater; this is a requirement for later steps in this installation procedure.

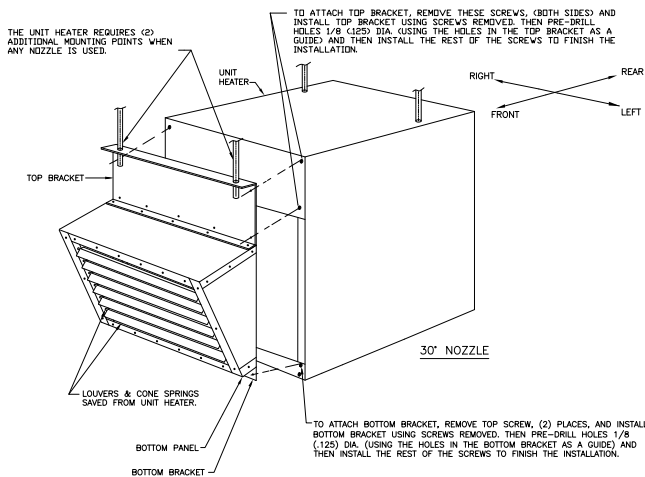

- For 30-degree nozzle assemblies: Go to [Step 10](#).
- For 60- and 90-degree nozzle assemblies: Using the enclosed #8-18 x 1/2 screws and with the top and bottom panels oriented such that the sides with the larger holes are facing the unit heater, create a sub-assembly by attaching the top panel (P/N 251-07942-00X) and the bottom panel (P/N 251-07943-00X) to the left side panel (P/N 251-07945) and to the right side panel (P/N 251-07947).

**Note:** The top and bottom panels must be attached so that the sides with the larger holes are facing the unit heater; this makes the assembly easier.

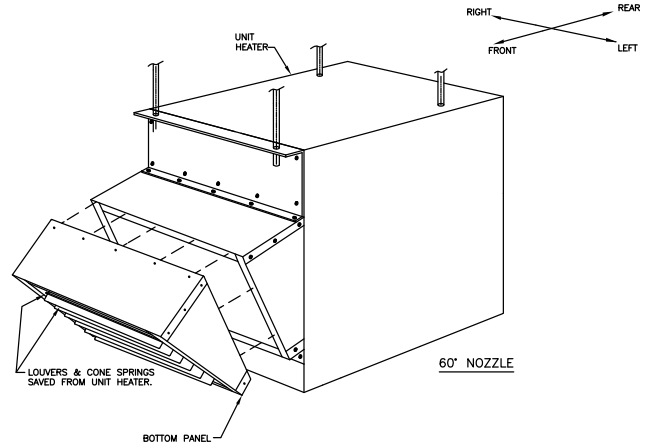

**Note:** For 90-degree nozzle assemblies, repeat [Step 8](#) to create a second sub-assembly.

- For 60- and 90-degree nozzle assemblies: Using the enclosed #8-18 x 1/2 screws, attach the sub-assembly created in [Step 8](#) to the 30-degree assembly installed to the unit (in [Step 1](#) through [Step 6](#) of this procedure). Attach the corresponding panels (i.e., top panel to top panel, right side panel to right side panel, etc).

**Note:** For 90-degree nozzle assemblies, install the second sub-assembly by attaching it to the first sub-assembly. Attach the corresponding panels (i.e., top panel to top panel, right side panel to right side panel, etc).

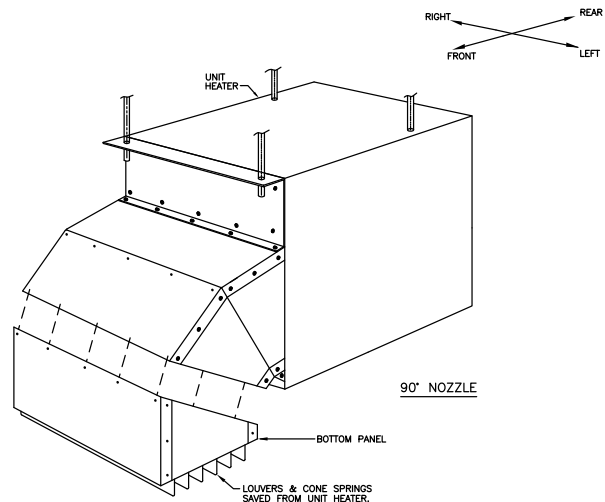

- Install the louvers and cone springs.





# Installation: Piping

## Gas Piping

### ⚠ WARNING

#### Flammable Vapors!

When connecting to existing gas lines be sure to valve off the gas supply ahead of connection point. To avoid explosion or possible fire, always purge all residual gas from piping before cutting into existing line or removing threaded fittings. Failure to remove all gas vapors could result in death or serious injury or equipment or property-only damage.

### Pipe Sizing

To provide adequate gas pressure to the gas duct furnace, size the gas piping as follows:

1. Find the ft<sup>3</sup>/hr by using the following formula:

$$\text{ft}^3/\text{hr} = \frac{\text{Input}}{\text{Btu per ft}^3}$$

2. Refer to [Table 4, p. 17](#). Match "Length of Pipe" with appropriate "Gas Input - Ft<sup>3</sup>/Hr" value. This value can then be matched to the pipe size at the left of the table.

Example: It is determined that a 67 foot (20.4 m) run of gas pipe is required to connect a 200 MBtu gas duct furnace to a 1,000 Btu/ft<sup>3</sup> (0.29 kW) natural gas supply.

$$\frac{200,000 \text{ Btu/hr}}{1,000 \text{ Btu/ft}^3} = 200 \text{ ft}^3/\text{hr}$$

Using [Table 4, p. 17](#), a 1-inch pipe is needed.

#### Notes:

- See "[General Safety Information](#)," p. 7 for English/SI (metric) unit conversion factors.
- If more than one gas duct furnace is to be served by the same piping arrangement, the total cubic feet per hour input and length of pipe must be considered.
- If the gas duct furnace is to be fired with LP gas, consult the local LP gas dealer for pipe size information.

### ⚠ WARNING

#### Hazard of Explosion and Fire!

Heater installation for use with propane (LP gas) must be made by a qualified LP Gas Dealer or LP Gas Installer to ensure that all appropriate codes, installation procedures, and precautions have been followed. Failure to follow these instructions could result in death or serious injury.

Before any connection is made to an existing line supplying other gas appliances, contact the local gas company to make certain that the existing line is of adequate size to handle the combined load.

**Table 4. Gas pipe size<sup>(a)</sup>**

Nominal Iron Pipe Size, in.	Internal Diameter, in. (mm)	Length of Pipe, ft (m)													
		10 (3.0)	20 (6.1)	30 (9.1)	40 (12.2)	50 (15.2)	60 (18.3)	70 (21.3)	80 (24.4)	90 (27.4)	100 (30.5)	125 (38.1)	150 (45.7)	175 (53.3)	200 (61.0)
1/2	0.622 (16)	175 (4.96)	120 (3.40)	97 (2.75)	82 (2.32)	73 (2.07)	66 (1.87)	61 (1.73)	57 (1.61)	53 (1.50)	50 (1.42)	44 (1.25)	40 (1.13)	37 (1.05)	35 (0.99)
3/4	0.824 (21)	360 (10.2)	250 (7.08)	200 (5.66)	170 (4.81)	151 (4.28)	138 (3.91)	125 (3.54)	118 (3.34)	110 (3.11)	103 (2.92)	93 (2.63)	84 (2.38)	77 (2.18)	72 (2.04)
1	1.049 (27)	680 (19.3)	465 (13.2)	375 (10.6)	320 (9.06)	285 (8.07)	260 (7.36)	240 (6.80)	220 (6.23)	205 (5.80)	195 (5.52)	175 (4.96)	160 (4.53)	145 (4.11)	135 (3.82)
1-1/4	1.380 (35)	1400 (39.6)	950 (26.9)	770 (21.8)	660 (18.7)	580 (16.4)	530 (15.0)	490 (13.9)	460 (13.0)	430 (12.2)	400 (11.3)	360 (10.2)	325 (9.20)	300 (8.50)	280 (7.93)
1-1/2	1.610 (41)	2100 (59.5)	1460 (41.3)	1180 (33.4)	990 (28.0)	900 (25.5)	810 (22.9)	750 (21.2)	690 (19.5)	650 (18.4)	620 (17.6)	550 (15.6)	500 (14.2)	460 (13.0)	430 (12.2)
2	2.067 (53)	3950 (112)	2750 (77.9)	2200 (62.3)	1900 (53.8)	1680 (47.6)	1520 (43.0)	1400 (39.6)	1300 (36.8)	1220 (34.5)	1150 (32.6)	1020 (28.9)	950 (26.9)	850 (24.1)	800 (22.7)
2-1/2	2.469 (63)	6300 (178)	4350 (123)	3520 (99.7)	3000 (85.0)	2650 (75.0)	2400 (68.0)	2250 (63.7)	2050 (58.0)	1950 (55.2)	1850 (52.4)	1650 (46.7)	1500 (42.5)	1370 (38.8)	1280 (36.2)
3	3.068 (78)	11000 (311)	7700 (218)	6250 (177)	5300 (150)	4750 (135)	4300 (122)	3900 (110)	3700 (105)	3450 (97.7)	3250 (92.0)	2950 (83.5)	2650 (75.0)	2450 (69.4)	2280 (64.6)
4	4.026 (102)	23000 (651)	15800 (447)	12800 (362)	10900 (309)	9700 (275)	8800 (249)	8100 (229)	7500 (212)	7200 (204)	6700 (190)	6000 (170)	5500 (156)	5000 (142)	4600 (130)

**Notes:**

1. Determine the required ft<sup>3</sup>/h by dividing the rated heater input by 1000. For SI / Metric measurements: Convert unit Btu/h to kilowatts. Multiply the unit input (kW) by 0.0965 to determine m<sup>3</sup>/h.
2. FOR NATURAL GAS: Select the pipe size directly from the table.
3. FOR PROPANE GAS: Multiply the ft<sup>3</sup>/h (m<sup>3</sup>/h) value by 0.633; then use the table.
4. Refer to the metric conversion factors listed in "General Safety Information," p. 7 for more SI unit measurements/conversions.

(a) Maximum capacity of pipe in cubic feet of gas per hour (cubic meters per hour) for gas pressures of 0.5 psig (3.5 kPa) or less, and a pressure drop of 0.5 inch water column (124.4 Pa) (based on a 0.60 specific gravity gas).

## Pipe Installation

1. Install the gas piping in accordance with applicable local codes.
2. Check gas supply pressure. Each duct furnace must be connected to a gas supply capable of supplying its full rated capacity as specified in [Table 5, p. 18](#). A field LP tank regulator must be used to limit the supply pressure to maximum of 14 in. wc (3.5 kPa). All piping should be sized in accordance with the latest edition of ANSI Standard Z223.1 National Fuel Gas Code; in Canada, according to CGA-B149. See [Table 1, p. 10](#), [Table 4, p. 17](#), and [Table 5, p. 18](#) for correct gas piping size.

If gas pressure is excessive on natural gas applications, install a pressure regulating valve in the line upstream from the main shutoff valve.

### WARNING

#### Hazard of Explosion!

**Adequately support the piping to prevent strain on the gas manifold and controls. To prevent explosion, fire, or gas leaks, support piping so that piping does not sag or put pressure on the burners internal to the unit. Failure to follow these recommendations could result in death or serious injury or equipment or property-only-damage.**

3. To prevent the mixing of moisture with gas, run the take-off piping from the top, or side, of the main.
4. Duct furnaces are shipped with a combination valve which includes:
  - a. Manual "A" valve
  - b. Manual "B" valve
  - c. Solenoid valve
  - d. Pilot safety
  - e. Pressure regulator

## Installation: Piping

- Pipe directly in to combination valve (see [Figure 8](#), p. 18).
- A 1/8 in. N.P.T. plugged tapping, accessible for test gauge connection, must be installed immediately upstream of the gas supply connection to the appliance.
  - Provide a drip leg in the gas piping near the gas duct furnace. A ground joint union and a manual gas shutoff valve should be installed ahead of the unit heater controls to permit servicing. The manual shutoff valve must be located external to the jacket (see [Figure 8](#), p. 18).
  - Make certain that all connections have been adequately doped and tightened.

### NOTICE:

#### Overtightening!

Do not overtighten the inlet gas piping into the valve. This may cause stresses that could crack the valve!

**Note:** Use pipe joint sealant resistant to the action of liquefied petroleum gases regardless of gas conducted.

### ⚠ WARNING

#### Hazard of Explosion!

Never use an open flame to detect gas leaks. Explosive conditions may occur. Use a leak test solution or other approved methods for leak testing. Failure to follow recommended safe leak test procedures could result in death or serious injury or equipment or property-only damage.

Figure 8. Pipe installation, standard controls

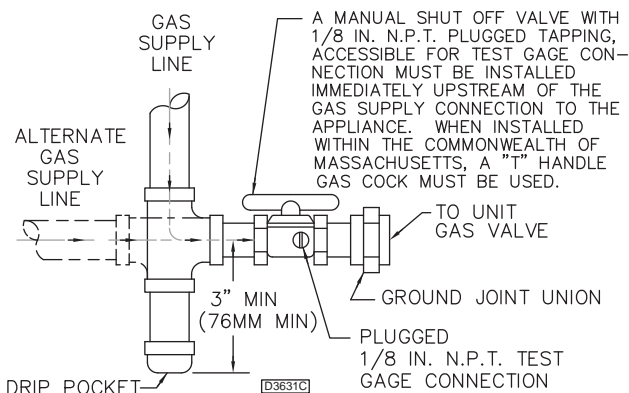

The appliance and its individual shutoff valve must be disconnected from the gas supply piping system during any pressure testing of that system in excess of 1/2 psig (3.5 kPa).

The appliance must be isolated from the gas supply piping system by closing its individual manual shutoff valve during any pressure testing of the gas supply piping system at test pressures equal to or less than 1/2 psig (3.5 kPa).

Table 5. Gas piping requirements<sup>(a)</sup>

Gas Type	Natural Gas	Propane (LP) Gas
Manifold Pressure	3.5 in. wc (0.9 kPa)	10.5 in. wc (2.6 kPa)
Supply Inlet Pressure	14.0 in. wc Max. (3.5 kPa)	14.0 in. wc Max. (3.5 kPa)
	5.5 in wc Min. (1.4 kPa)	13.0 in wc Min. (3.2 kPa)

(a)

## Installation: Venting

### Combustion Air Venting and Piping

### ⚠ WARNING

#### Exhaust Fumes!

Each duct furnace **MUST** have its own combustion air system and **MUST NOT** be connected to other air intake systems. To prevent exhaust fumes from being pulled into the air intake system or improper heating, ensure that the duct furnace has its own combustion air system and is not connected to other air intake systems. Failure to follow these recommendations could result in death or serious injury or equipment damage.

### ⚠ WARNING

#### Carbon Monoxide!

Your venting system must not be blocked by any snow, snow drifts, or any foreign matter. Inspect your venting system to ensure adequate ventilation exists at all times! A blocked venting system could result in carbon monoxide poisoning. Symptoms of such condition include grogginess, lethargy, inappropriate tiredness, or flu-like symptoms. Failure to follow these recommendations could result in death or serious injury.

### ⚠ WARNING

#### Risk of Fire and Carbon Monoxide Poisoning with Improper Piping!

Never use pipe of a diameter other than that specified in [Table 1, p. 10](#) ("D" dia. flue opening)! To prevent pipe from melting and introducing exhaust fumes into the air supply, never use PVC, ABS or any other non-metallic pipe for venting! Failure to follow these recommendations could result in death or serious injury or equipment damage.

1. The combustion air system installation must be in accordance with the latest edition of (N.F.P.A. 54) ANSI Z223.1 National Fuel Gas Code. In Canada, installation must be in accordance with CGA-B149.1 "Installation Code for Natural Gas Burning Appliances or Equipment" and CGA-B149.2 "Installation Code for Propane Burning Appliances and Equipment".
2. A Breidert Type L or Fields inlet cap, furnished by the customer, must be installed at the termination point of the combustion air system (see [Figure 9, p. 21](#) and [Figure 10, p. 21](#)).

**Note:** The top of the inlet cap is to be no less than 12 inches (305 mm) from the top of the exhaust vent cap (see [Figure 9, p. 21](#) and [Figure 10, p. 21](#)).

3. Use single wall pipe constructed of 26 gauge galvanized steel or a material of equivalent durability and corrosion resistance for the combustion air system. For installation in Canada, use pipe constructed from 0.025-inch thick aluminum or 0.018-inch thick stainless steel.
4. Long runs of single wall combustion air piping passing through an unheated space may require insulating if condensation becomes noticeable.
5. The combustion air system must be installed to prevent collection of condensate. Pitch horizontal pipes downward 1/4 inch per foot (21 mm/m) toward the inlet cap to facilitate drainage. Vertical combustion air pipes should be arranged as depicted in [Figure 9, p. 21](#).
6. The equivalent length of the combustion air system must not be less than five feet (1.5 m) and must not exceed 50 feet (15.2 m). Equivalent length equals the total length of straight pipe, plus 15 feet (4.6 m) for each 90-degree elbow and five feet (1.5 m) for each 45-degree elbow.

**Note:** For optimum performance, keep the combustion air system as straight as possible.

7. Each slip joint must be secured with at least three corrosion resistant screws. Two full turns of 3M™ #425 Aluminum Foil Tape or its equivalent must then be used to seal each joint. General Electric RTV-108, Dow

Corning® RTV-732 or an equivalent may be used instead of the tape.

8. For horizontal combustion air systems longer than five feet (1.5 m), the system must be supported from overhead building structures at three-foot (1-m) intervals.

### Exhaust Venting

### ⚠ WARNING

#### Carbon Monoxide!

Never operate duct furnaces without combustion air and flue gas piping in place. Each unit **MUST** have its own combustion air system and **MUST NOT** be connected to other vent systems or to a chimney. Your venting system must not be blocked by any snow, snow drifts, or any foreign matter. Inspect your venting system to ensure adequate ventilation exists at all times! Failure to follow these recommendations could result in death or serious injury.

### ⚠ WARNING

#### Risk of Fire and Carbon Monoxide Poisoning with Improper Piping!

Never use pipe of a diameter other than that specified in [Table 1, p. 10](#) ("D" dia. flue opening)! To prevent pipe from melting and introducing exhaust fumes into the air supply, never use PVC, ABS or any other non-metallic pipe for venting! Failure to follow recommendations could result in death or serious injury or equipment damage.

1. Vent system installation must be in accordance with the latest edition of (N.F.P.A. 54) ANSI Z223.1 National Fuel Gas Code. In Canada installation must be in accordance with CGA-B149.1 "Installation Code for Natural Gas Burning Appliances and Equipment" or CGA-B149.2 "Installation Code for Propane Burning Appliances and Equipment".
2. A Breidert Type L or Fields vent cap, furnished by the customer, must be installed at the termination point of the vent system (see [Figure 9, p. 21](#) and [Figure 10, p. 21](#)).
3. Use single wall pipe constructed of 26 gauge galvanized steel or a material of equivalent durability and corrosion resistance for the vent system. For installations in Canada, use corrosion resistant and gas-tight, listed vent pipe conforming with local building codes, or in the absence of local building codes, with current CAN/CGA-B149.1, "Installation Codes for Natural Gas Burning Appliances and Equipment" or CAN/CGA-B149.2, "Installation Codes for Propane Gas Burning Appliances and Equipment".

## Installation: Piping

---

4. Any run of single wall vent pipe passing through an unheated space must be insulated with an insulation suitable to 550°F (288°C).
5. The combustion and exhaust vent air systems must be installed to prevent collection of condensate. Pitch horizontal pipes downward 1/4 inch per foot (21 mm/m) toward the terminal cap to facilitate drainage (see [Figure 11, p. 21](#)). Vertical vent pipes should be arranged as depicted in [Figure 9, p. 21](#).
6. The equivalent length of the vent system must not be less than five feet (1.5 m) and must not exceed 50 feet (15.2 m). Equivalent length equals the total length of straight pipe plus 15 feet (4.6 m) for each 90-degree elbow and five feet (1.5 m) for each 45-degree elbow.
7. Each slip joint must be secured with at least three corrosion resistant screws. Two full turns of 3M™ #425 Aluminum Foil tape or its equivalent must then be used to seal each joint. General Electric RTV-108, Dow Corning® RTV-732, or an equivalent may be used instead of the tape.
8. For horizontal vent systems longer than five feet (1.5 m), the system must be supported from overhead building structures at three-foot (1-m) intervals.
9. The exhaust vent system must remain at a minimum of six inches (152 mm) from all combustible materials. Any part of the vent system that passes through a combustible material must be properly insulated.

**Note:** *Increasing the clearance distances may be necessary if there is a possibility of distortion or discoloration of adjacent materials.*

For a VERTICAL vent pipe section that passes through a floor or roof, an opening four inches (102 mm) greater in diameter is required. The opening must be insulated and flashed in accordance with applicable installation codes.

A HORIZONTAL section of an exhaust vent system that passes through a combustible wall must be constructed and insulated as shown in [Figure 12, p. 21](#).

10. The top of a VERTICALLY VENTED exhaust system must extend at least three feet (1 m) above the roof surface that it passes through. The point of termination for a HORIZONTALLY VENTED exhaust system must be at least 12 inches (305 mm) from the exterior wall that it passes through. In addition, the termination point must be at least three feet (1 m) above the snow line, more than six feet (2 m) from the combustion air inlet of another appliance, more than three feet (1 m) from any building opening, and more than four feet (1.3 m) from, and not directly above, any electric meter, regulator, or relief equipment (refer to [Figure 10, p. 21](#) and [Figure 12, p. 21](#)).

**Figure 9. Vertical intake/vent installation**

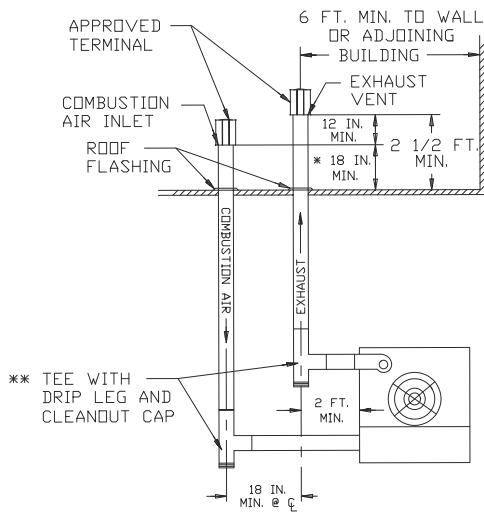

- \* Size according to expected snow depth
- \*\* If excessive condensation develops, a drip leg with a condensate drain may be required. Insulating the pipes may eliminate the problem.

**Figure 10. Vertical vent installation**

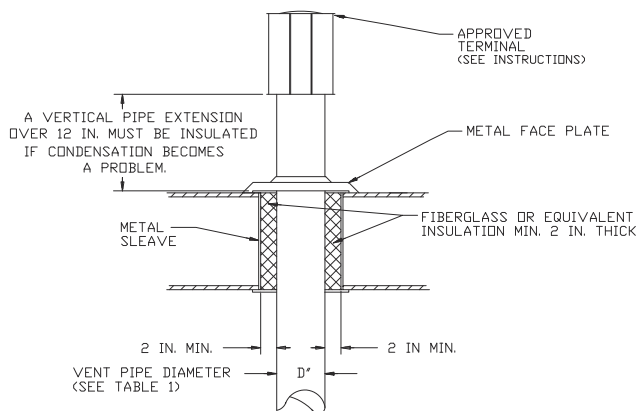

**Figure 11. Horizontal intake/vent locations**

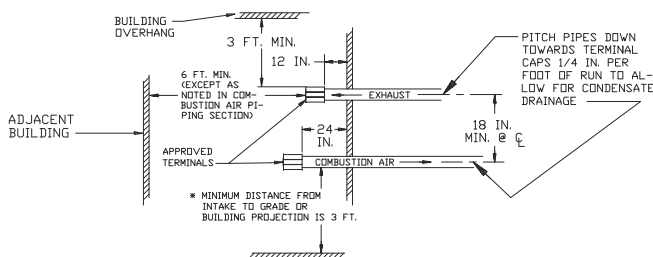

**Figure 12. Horizontal vent installation**

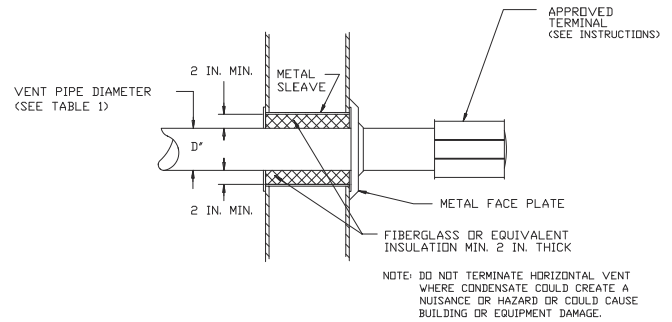

## Installation: Concentric Vent Terminal

### ⚠ WARNING

#### Hazardous Service Procedures!

The maintenance and troubleshooting procedures recommended in this manual could result in exposure to electrical, mechanical or other potential safety hazards. Always refer to the safety warnings provided throughout this manual concerning these procedures. When possible, disconnect all electrical power including remote disconnect and discharge all energy storing devices such as capacitors before servicing. Follow proper lockout/tagout procedures to ensure the power can not be inadvertently energized. When necessary to work with live electrical components, have a qualified licensed electrician or other individual who has been trained in handling live electrical components perform these tasks. Failure to follow all of the recommended safety warnings provided, could result in death or serious injury.

### Horizontal Termination

Select a location on an outside wall for the vent terminal. In most applications, the terminal should be on level with the flue outlet of the unit, less 1/4 inch per foot pitch for condensate drainage toward the outside of the building (see [Figure 13, p. 22](#)).



## Installation: Piping

**Figure 13. Horizontal concentric venting**

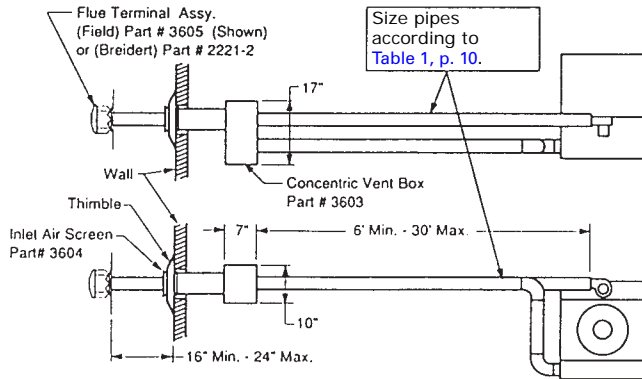

The location of the vent terminal must be in accordance with the National Fuel Gas Code ANSI Z223.1 in the U.S. or the National Gas Installation Code CAN/CGA-B149.1 or the Propane Gas Installation Code CAN/CGA-149.2 in Canada. Minimum clearance are as follows:

**Table 6. Horizontal concentric venting—minimum clearance**

Object	Minimum Clearance	
	U.S.	Canada
Forced air inlet within 10 feet	3 feet above	6 feet
Door, window or gravity air inlet or combustion air inlet for other appliance	4 feet below 4 feet horizontally 1 foot above	12 inches for 100,000 Btu/h input or less. 3 feet for input exceeding 100,000 Btu/h.
Adjacent public walkways	7 feet above grade	7 feet above grade
Above grade level	1 foot	1 foot

In Canada, a vent shall not terminate above a meter/regulator assembly within 3 feet horizontally of the vertical center line of the regulator nor within 6 feet of any gas service regulator vent outlet.

Cut a hole through the wall for an 8-inch combustion air pipe. Install thimble if required by local codes or type of wall construction (see [Figure 14, p. 22, Step 1](#)).

Fasten a length of 5-inch pipe to the exhaust connection of the concentric adapter with sheet metal screws. Use at least three corrosion-resistant screws per joint. Seal all joints with high temperature silicone sealant. The concentric adapter box may be fastened directly to the wall or spaced away from the wall using suitable brackets (field-supplied). Before mounting the box, cut a length of 8-inch pipe so that it will protrude 2 inches through the wall when the box is mounted in position. Fasten the 8-inch pipe to the combustion air inlet connection of the concentric adapter and seal the joint. Add an additional 5-inch pipe, if necessary, so that the base of the exhaust cap will be 16 to 24 inches from the combustion air inlet (see [Figure 14, p. 22, Step 2](#)).

Insert the pipes through the wall and fasten the adapter box in place. Flash and/or caulk 8-inch pipe on outside wall (see [Figure 14, p. 22, Step 3](#)).

Install the inlet air screen on the 8-inch pipe and fasten with sheet metal screws. Install the flue terminal on the 5-inch pipe and fasten in place (see [Figure 14, p. 22, Step 4](#)).

**Figure 14. Horizontal concentric venting—installation**

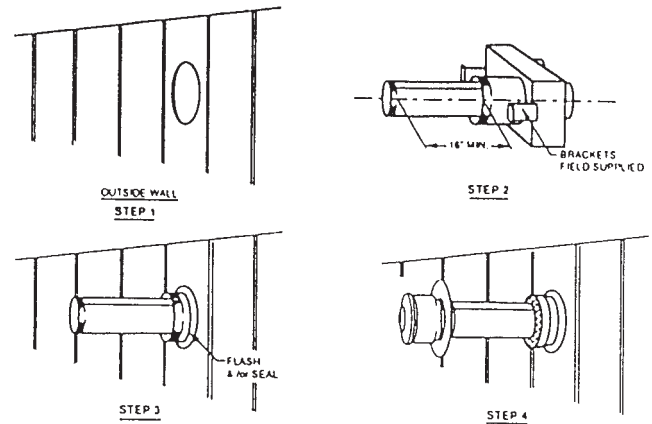

Connect the flue pipe and the combustion air pipe from the concentric adapter to the unit. The pipe must be single wall 26-gauge or heavier galvanized steel or a material of equivalent durability and corrosion resistance. The pipe diameter must be listed under inlet and flue size in [Table 1, p. 10](#). The equivalent length of the exhaust vent pipe must be a minimum of 5 feet and a maximum of 50 feet. The equivalent length equals the total length of straight pipe plus 15 feet for each 90-degree elbow and 5 feet for each 45-degree elbow. Secure each joint with a minimum of three corrosion resistant screws. Seal all joints of the exhaust vent pipe with two full turns of 3M #425 Aluminum Foil Tape or its equivalent suitable for 550°F or high temperature silicone sealant. Seal all joints of the combustion air inlet pipe with two full turns of duct tape or aluminum foil tape or silicone sealant.

### Vertical Termination

Select a location on the roof for the vent terminal, ensuring adequate space inside for the concentric vent box. The terminal must be at least 6 feet from any wall or adjoining building (see [Figure 15, p. 23](#)).

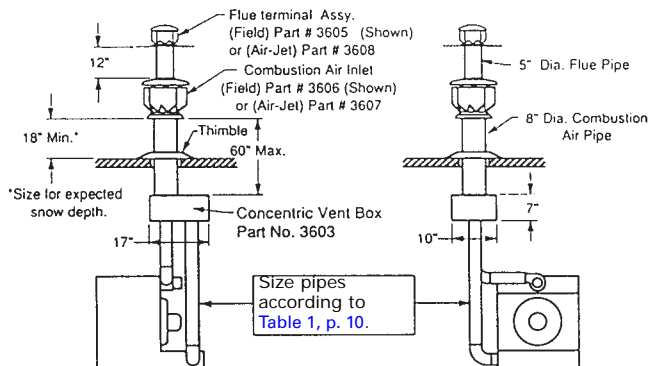

**Figure 15. Vertical concentric venting**

Cut a hole through the roof for an 8-inch combustion air pipe. Fasten a length of 5-inch pipe to the exhaust connection of the concentric adapter with sheet metal screws. Use at least three screws per joint. Seal all joints with high temperature silicone sealant. The concentric adapter box is to be suspended from the underside of the roof using suitable brackets (field-supplied). Before mounting the box, cut a length of 8-inch pipe so that dimension A (see Figure 16, p. 23, Step 1), is equal to the roof thickness plus 18 inches or the roof thickness plus the expected snow depth, whichever is greater. Fasten the 8-inch pipe to the combustion air inlet connection of the concentric adapter and seal the joint. Add an additional 5-inch pipe to extend at least 20 inches above the top of the 8-inch pipe.

Insert the pipe through the roof and fasten the adapter box in place (see Figure 16, p. 23, Step 2).

Flash and/or caulk the 8-inch pipe to the roof (see Figure 16, p. 23, Step 3).

Install the inlet air cap on the 8-inch pipe and fasten with sheet metal screws. Install the flue terminal on the 5-inch pipe and fasten in place. Seal the joint between the 5-inch pipe and the inlet air cap with silicone sealant to prevent the entry of water (see Figure 16, p. 23, Step 4).

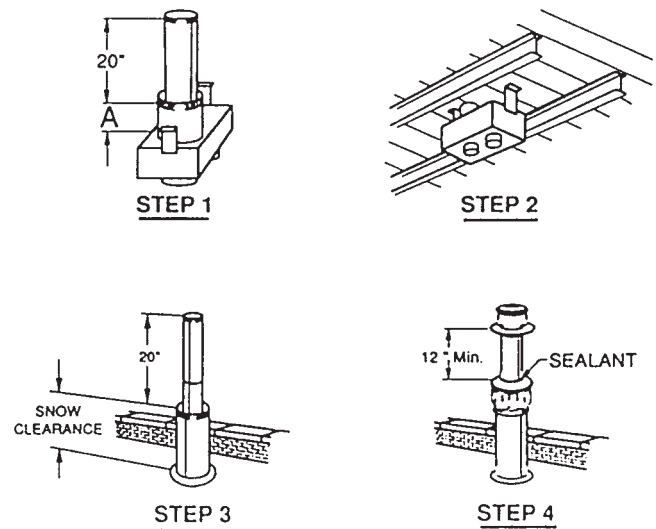
**Figure 16. Vertical concentric venting—installation**

Connect the flue pipe and the combustion air pipe from the concentric adapter to the unit. Pipe must be single wall 26-gauge or heavier galvanized steel or a material of equivalent durability and corrosion resistance. Pipe diameter must be as listed under inlet and flue size in Table 1, p. 10. The equivalent length of the exhaust vent pipe must be a minimum of 5 feet and a maximum of 50 feet. The equivalent length equals the total length of straight pipe plus 15 feet for each 90-degree elbow and 5 feet for each 45-degree elbow. Secure each joint with a minimum of three corrosion-resistant screws. Seal all joints of the exhaust vent pipe with two full turns of 3M #425 Aluminum Foil Tape or its equivalent suitable for 550°F or high temperature silicone sealant. Seal all joints of the combustion air inlet pipe with two full turns of duct tape or aluminum foil tape or silicone sealant. Do not enclose the exhaust vent pipe or run the pipe within 6 inches of combustible material.



# Installation: Electrical

## Electrical Connections

### ⚠ WARNING

#### Hazardous Service Procedures!

The maintenance and troubleshooting procedures recommended in this section of the manual could result in exposure to electrical, mechanical or other potential safety hazards. Always refer to the safety warnings provided throughout this manual concerning these procedures. When possible, disconnect all electrical power including remote disconnect and discharge all energy storing devices such as capacitors before servicing. Follow proper lockout/tagout procedures to ensure the power can not be inadvertently energized. When necessary to work with live electrical components, have a qualified licensed electrician or other individual who has been trained in handling live electrical components perform these tasks. Failure to follow all of the recommended safety warnings provided, could result in death or serious injury.

### ⚠ WARNING

#### Hazardous Voltage and Gas!

Turn off the gas supply and disconnect all electric power, including remote disconnects before servicing unit. Follow proper lockout/tagout procedures to ensure the power can not be inadvertently energized and the gas can not be inadvertently turned on. Failure to turn off gas or disconnect power before servicing could result in death or serious injury.

### ⚠ WARNING

#### Proper Field Wiring and Grounding Required!

All field wiring **MUST** be performed by qualified personnel. Improperly installed and grounded field wiring poses **FIRE & ELECTROCUTION** hazards. To avoid these hazards, you **MUST** follow requirements for field wiring installation and grounding as described in NEC and your local/state electrical codes. Failure to follow these requirements could result in death or serious injury.

Standard units are shipped for use on 115 volt, 60 hertz single phase electric power. The motor nameplate and electrical rating of the transformer should be checked before energizing the duct furnace electrical system. All external wiring must conform to the latest edition of ANSI/NFPA No. 70 National Electrical Code and applicable local codes; in Canada, to the Canadian Electrical Code, Part 1 CSA Standard C22.1.

### NOTICE:

#### Use Copper Conductors Only!

Unit terminals are not designed to accept other types of conductors. Failure to use copper conductors could result in equipment damage.

It is recommended that the electrical power supply to each duct furnace be provided by a separate, fused, and permanently live electrical circuit. A disconnect switch of suitable electrical rating should be located as close to the gas valve as possible. Each duct furnace must be electrically grounded in accordance with the latest edition of the National Electric Code, ANSI/NFPA No. 70 or CSA Standard C22.1. Sample wiring connections are depicted in [Figure 22, p. 39](#) and [Figure 23, p. 40](#).

### Thermostat Wiring and Location

**Note:** The thermostat must be mounted on a vertical, vibration-free surface, free from air currents, and in accordance with the furnished instructions.

Mount the thermostat approximately 5 feet (1.5 m) above the floor in an area where it will be exposed to a free circulation of average temperature air. Always refer to the thermostat instructions as well as our unit wiring diagram, and wire accordingly. Avoid mounting the thermostat in the following locations:

1. Cold areas—Outside walls or areas where drafts may affect the operation of the control.
2. Hot areas—Areas where the sun's rays, radiation, or warm air currents may affect control operation.
3. Dead areas—Areas where air cannot circulate freely, such as behind doors or in corners.

**Note:** Thermostat wires tagged "W" and "G" must be connected together except when using a general purpose "SPDT" 24 Vac relay and a standard thermostat with subbase, or when using Honeywell T834H or T834N thermostats. Also refer to [Figure 17, p. 24](#) for other wiring connections.

Figure 17. C1267G, thermostat wiring diagram

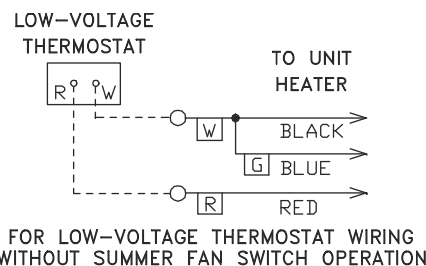

**Thermostat Heat Anticipator Adjustments.** The initial heat anticipator setpoint should equal the thermostat's current amperage draw when the unit is

firing. This setpoint should be measured for the best results. Use the recommended ranges as a guide. If further information is needed, consult your thermostat manufacturer's instructions.

Recommended Heat Anticipator Setting Ranges:

<b>25 ft. (7.6 m) T'stat Wiring</b>	<b>50 ft. (15.2 m) T'stat Wiring</b>
0.85 to 0.90 A	0.90 to 1.1 A Max. Setting on T'stat

### Fan Time Delay Control

Leads from the fan time delay controls are factory wired to the junction box. The fan control is a time delay relay (approximately 45 seconds ON, 65 seconds OFF). The fan control is rated at 17 amps.

**Notes:**

- *The start-up fan delay should not exceed 90 seconds from a cold start.*
- *For all wiring connections, refer to the wiring diagram shipped with your unit (either affixed to the side jacket or enclosed in your unit's installation instruction envelope). Should any original wire supplied with the heater have to be replaced, it must be replaced with wiring material having a temperature rating of at least 105°C.*

*Should any high limit wires have to be replaced, they must be replaced with wiring material having a temperature rating of 200°C minimum.*



# Start-Up

## Operation

### Explanation of Controls

#### **⚠ WARNING**

##### **Carbon Monoxide!**

Never operate duct furnaces if the power venter is not operable. Your venting system must not be blocked by any snow, snow drifts, or any foreign matter. Inspect your venting system to ensure adequate ventilation exists at all times! Failure to follow these recommendations could result in death or serious injury due to Carbon Monoxide Poisoning (symptoms include grogginess, lethargy, inappropriate tiredness, or flu-like symptoms).

1. Each Separated Combustion Duct Furnace comes equipped with a power vent system that consists of a power venter motor and blower, pressure switch, and sealed flue collector (Figure 20, p. 32).

#### **NOTICE:**

##### **Additional Devices!**

The addition of external draft hoods or power venters is not permitted. Addition of such devices could cause severe unit malfunction or failure!

2. The power venter motor is energized by the room thermostat when a demand for heat is sensed. The pressure switch measures the pressure differential between the air inlet and exhaust vent systems. If the differential is correct, the indirect spark ignition system is energized.
3. The indirect spark ignition system consists of an ignition module, a dual combination valve, and a spark-ignited pilot burner. When the pressure switch is closed, the pilot valve opens as a spark is generated to light the pilot. When the flame is sensed by the flame sensing circuit, the spark ceases, and the main gas valve is opened to supply gas to the main burners. Once the thermostat has been satisfied, the vent system and gas valve are simultaneously de-energized, stopping all gas flow to the unit.

### Shut-Down

1. Turn the valve selector knob to the OFF position.
2. Turn off the electricity.
3. To relight, follow the instructions in "Initial Lighting," p. 26 (preceding section).

4. The high limit switch interrupts the flow of electric current to the main gas valve if the duct furnace becomes overheated.
5. The optional fan switch delays the operation of the fan is delayed for approximately 45 seconds once the thermostat is closed, and continues fan operation for approximately 65 seconds after the thermostat opens.

**Note:** The start-up fan delay must not exceed 90 seconds from a cold start.

6. The wall thermostat, supplied optionally, is a temperature sensitive switch that operates the vent and ignition systems to control the temperature of the space being heated.

**Note:** The thermostat must be mounted on a vertical, vibration-free surface, free from air currents, and in accordance with the furnished instructions.

### Initial Lighting

1. Open the manual gas valve, in the gas supply line to the duct furnace. Loosen the union in the gas supply line to purge it of air. Tighten the union and check for leaks.

#### **⚠ WARNING**

##### **Hazard of Explosion!**

Never use an open flame to detect gas leaks. Explosive conditions may occur. Use a leak test solution or other approved methods for leak testing. Before attempting to light or relight the pilot, wait 5 minutes to allow gas which may have accumulated in the burner compartment to escape. Failure to follow recommended safe leak test procedures or pilot lighting/relighting instructions could result in death or serious injury or equipment or property-only-damage.

2. Turn on the electrical power. The duct furnace should now be under the control of the thermostat. Set the thermostat to its highest setting; the power venter motor should start and burner ignition occur. Turn the thermostat to its lowest setting. The burners and power venter should stop operating immediately. Reset the thermostat to the desired operational setting.

**Figure 18. Burner components (intermittent pilot ignition)**

**Burner Drawer Common Parts:**

- 1. Main Burners
- 2. Burner Manifold
- 3. Air Shutters
- 4. Burner Springs
- 5. Main Burner Orifice
- 6. Transformer
- 7. Pilot Tubing

**Controls:**

- 8A. Main Gas Valve (Honeywell)
- 8B. Main Gas Valve (White-Rodgers)
- 9. Honeywell Ignitor
- 10. Honeywell Pilot Burner
- 11. Honeywell Pilot Orifice
- 12. Honeywell Electrode/Sensor Lead
- 13. Hi Limit Switch (Located on Rear Header Plate of Heat Exchanger, Air Inlet Side)

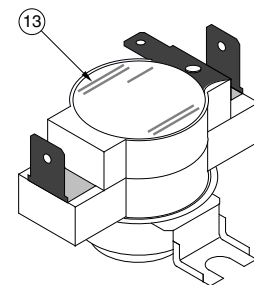
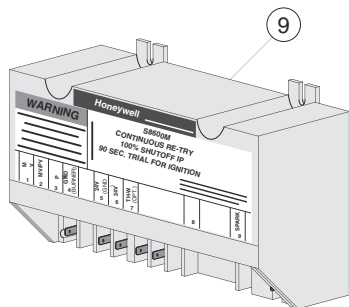
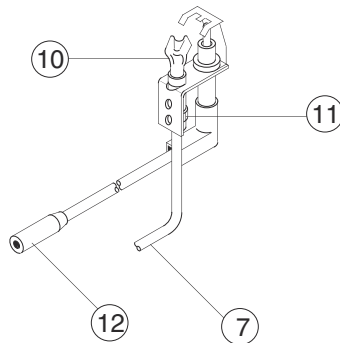
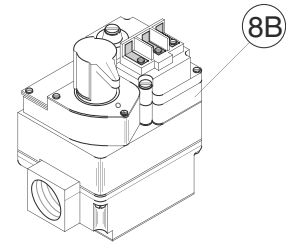
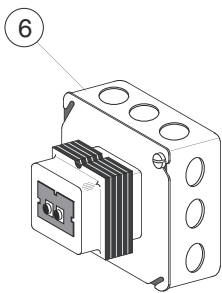
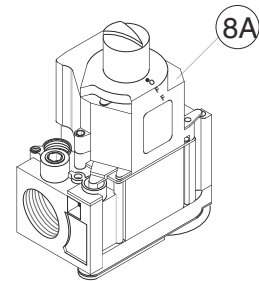
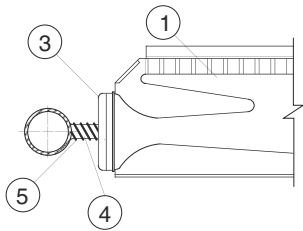
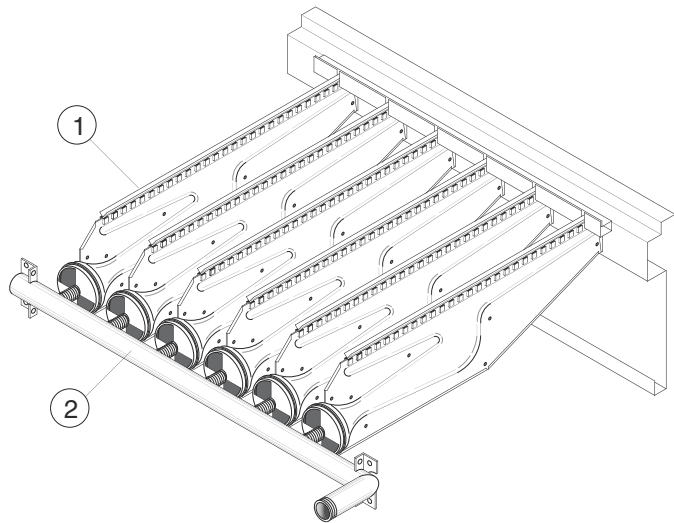



## Start-Up

### Gas Input Rate

#### NOTICE:

#### Overfiring!

Never overfire the duct furnace, as this could cause unsatisfactory operation, or shorten the life of the heater.

Check the gas input rate as follows:

1. Turn off all gas appliances that utilize gas through the same gas meter as the unit heater.
2. Turn gas on to the unit heater.
3. Using the gas meter, clock the time that it takes to burn one cubic foot of gas (Heating Value).
4. Insert the time, in seconds, into the formula below:

$$\text{Input Rate} = \frac{\text{Heating Value (Btu/ft}^3\text{)} (3600 \text{ s/hr})}{\text{Time (s/ft}^3\text{)}}$$

Example: If the heating value = 1000 BTU/ft<sup>3</sup> and the time/ft<sup>3</sup> = 18 s/ft<sup>3</sup> then

$$\text{Input Rate} = \frac{(1000 \text{ BTU/ft}^3) (3600 \text{ s/hr})}{18 \text{ s/ft}^3}$$

Input Rate = 200,000 BTU/hr

(Refer to "General Safety Information," p. 7 for metric conversions.)

**Note:** If the computation exceeds, or is less than 95 percent of the gas Btu/h input rating (see "Unit Dimensions and Weights," p. 10), adjust the gas pressure.

### Gas Pressure Adjustments

Adjust the gas pressure as follows:

1. **NATURAL GAS:** Best results are obtained when the duct furnace is operating at its full input rating with the manifold pressure of 3.5 inches wc (0.9 kPa). Adjustment of the pressure regulator is not normally necessary since it is preset at the factory. However, field adjustment may be made as follows:
  - a. Attach manometer at pressure tap plug below the control outlet.
  - b. Remove the regulator adjustment screw cap, located on the combination gas valve.
  - c. With a small screwdriver, rotate the adjustment screw clockwise to increase pressure.
  - d. Replace regulator adjustment screw cap.
2. **PROPANE GAS:** An exact manifold pressure of 10.0 inches wc (2.5 kPa) must be maintained for proper operation of the duct furnace. If the unit is equipped with a pressure regulator on the combination gas valve, follow [Step a](#) through [Step d](#) (above). If the unit is not so equipped, the propane gas supply system

pressure must be regulated to attain this manifold operating pressure.

Table 7. Main burner orifice schedule<sup>(a)</sup>

Input in 1000 BTU(a)	Type of Gas	Natural		No. of Burner Orifices
		Heating Value	Propane	
Manifold Pressure		1075 BTU/ft <sup>3</sup> (40.1 MJ/m <sup>3</sup> )	2500 BTU/ft <sup>3</sup> (93.1 MJ/m <sup>3</sup> )	
		3.5" wc (0.9 kPa)	10.5" wc (2.6 kPa)	
100	ft <sup>3</sup> /hr	96	40	4
	Orifice Drill	42	54	
125	ft <sup>3</sup> /hr	120	50	5
	Orifice Drill	42	54	
150	ft <sup>3</sup> /hr	140	60	6
	Orifice Drill	42	54	
175	ft <sup>3</sup> /hr	163	70	7
	Orifice Drill	42	54	
200	ft <sup>3</sup> /hr	186	80	8
	Orifice Drill	42	54	
225	ft <sup>3</sup> /hr	210	90	9
	Orifice Drill	42	54	
250	ft <sup>3</sup> /hr	233	100	10
	Orifice Drill	42	54	
300	ft <sup>3</sup> /hr	280	120	12
	Orifice Drill	42	54	
350	ft <sup>3</sup> /hr	326	140	14
	Orifice Drill	42	54	
400	ft <sup>3</sup> /hr	372	160	16
	Orifice Drill	42	54	

**Note:** When installed in Canada, any references to deration at altitudes in excess of 2000 feet (610 m) are to be ignored. At altitudes of 2000 to 4500 feet (610 to 1372 m), the unit heaters must be orificed to 90 percent of the normal altitude rating, and be so marked in accordance with the CSA certification.

(a) This schedule is for units operating at normal altitudes of 2000 feet (610 m) or less. SPECIAL ORIFICES ARE REQUIRED FOR INSTALLATIONS ABOVE 2,000 FEET (610 m).

### Primary Air Shutter Adjustment

After the unit has been operating for at least 15 minutes, adjust the primary air flow to the burners. Turn the friction-locked, manually-rotated air shutters clockwise to close, or counterclockwise to open.

For correct air adjustment, close the air shutter until yellow tips in the flame appear. Then open the air shutter to the point just beyond the position where yellow tipping disappears. Refer to [Figure 19](#).

**Note:** There may be momentary and spasmodic orange flashes in the flame. This is caused by the burning of airborne dust particles, and should not be confused with the yellow tipping, which is a stable or permanent situation when there is insufficient primary air.

**Figure 19. Main burner flames**

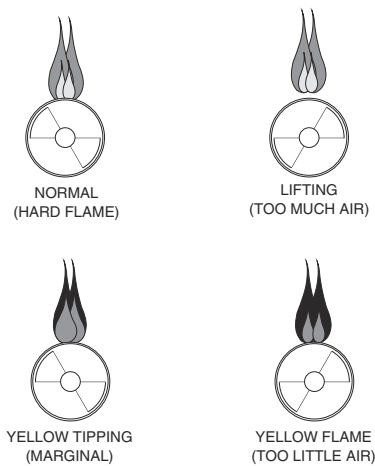

### **Pilot Adjustment**

1. Remove the pilot adjustment cap.
2. Adjust the pilot screw to provide a properly sized flame.
3. A proper pilot flame is a soft steady flame that envelops 3/8- to 1/2-inch (9.5 to 12.7 mm) of the flame sensor.
4. Replace the pilot adjustment cap.

### **Manifold Pressure Adjustment**

If the manifold pressure requires adjustment, remove the cap from the pressure regulator and turn the adjustment screw clockwise to increase the pressure, or counterclockwise to decrease the pressure. The adjusted manifold pressure should not vary more than 10 percent from the pressures specified in [Table 7, p. 28](#).





# Start-Up

## Gas Equipment Start-Up

Customer \_\_\_\_\_ Job Name & Number \_\_\_\_\_

### Pre-Inspection Information with Power and Gas Off

Type of Equip: \_\_\_\_\_ Duct Furnace  
 Serial Number: \_\_\_\_\_ Model Number: \_\_\_\_\_  
 Name Plate Voltage: \_\_\_\_\_ Name Plate Amperage: \_\_\_\_\_  
 Type of Gas: Natural LP Tank Capacity: \_\_\_\_\_ lb Rating: \_\_\_\_\_ Btu @ \_\_\_\_\_ °F  
 \_\_\_\_\_ kg \_\_\_\_\_ kW @ \_\_\_\_\_ °C

- Are all panels, doors, vent caps in place?
- Has the unit suffered any external damage? Damage \_\_\_\_\_
- Does the gas piping and electric wiring appear to be installed in a professional manner?
- Has the gas and electric been inspected by the local authority having jurisdiction?
- Is the gas supply properly sized for the equipment?
- Were the installation instructions followed when the equipment was installed?
- Have all field installed controls been installed?
- Do you understand all the controls on this equipment? **If not, contact your wholesaler or rep. (DO NOT START this equipment unless you fully understand the controls.)**

#### GENERAL

##### With power and gas off.

- Make certain all packing has been removed.
- Tighten all electrical terminals and connections.
- Check all fans and blowers for free movement.
- Check all controls for proper settings.
- Check all set screws on blowers and bearings.
- Check belt tightness.

#### BLOWER

##### With power on and gas off.

- Check voltage L1 \_\_\_\_\_ L2 \_\_\_\_\_ L3 \_\_\_\_\_
- Check rotation of main .
- Check motor amps L1 \_\_\_\_\_ L2 \_\_\_\_\_ L3 \_\_\_\_\_
- Blower RPM \_\_\_\_\_
- Check air filters. (Record quantity & size.)

#### GAS HEATING

##### With power and gas on.

- Inlet gas pressure. \_\_\_\_\_ in. wc or \_\_\_\_\_ kPa
- Pilot and main burner ignition.
- Manifold gas pressure. \_\_\_\_\_ in. wc or \_\_\_\_\_ kPa
- Cycle firestat and/or freezestat.
- Check electronic modulation. Set at: \_\_\_\_\_
- Cycle and check all other controls not listed.
- Check operation of remote panel.
- Entering air temp. \_\_\_\_\_ °F or \_\_\_\_\_ °C
- Discharge air temp. (high fire) \_\_\_\_\_ °F. or \_\_\_\_\_ °C
- External static pressure \_\_\_\_\_ in. wc

Remarks: \_\_\_\_\_

\_\_\_\_\_

# Maintenance

## ⚠ WARNING

### Hazardous Service Procedures!

The maintenance and troubleshooting procedures recommended in this section of the manual could result in exposure to electrical, mechanical or other potential safety hazards. Always refer to the safety warnings provided throughout this manual concerning these procedures. When possible, disconnect all electrical power including remote disconnect and discharge all energy storing devices such as capacitors before servicing. Follow proper lockout/tagout procedures to ensure the power can not be inadvertently energized. When necessary to work with live electrical components, have a qualified licensed electrician or other individual who has been trained in handling live electrical components perform these tasks. Failure to follow all of the recommended safety warnings provided, could result in death or serious injury.

## Periodic Service

All Maintenance/Service information should be recorded accordingly on the inspection sheet provided in this manual (see [“Gas Equipment Start-Up,”](#) p. 30).

**Note:** *The heater and vent system should be checked once a year by a qualified technician.*

## ⚠ WARNING

### Hazardous Voltage and Gas!

Turn off the gas supply and disconnect all electric power, including remote disconnects before servicing unit. Follow proper lockout/tagout procedures to ensure the power can not be inadvertently energized and the gas can not be inadvertently turned on. Failure to turn off gas or disconnect power before servicing could result in death or serious injury.

**Important:** *Gas tightness of the safety shut-off valves must be checked on at least an annual basis.*

## ⚠ WARNING

### Hazard of Explosion!

Never use an open flame to detect gas leaks. Explosive conditions may occur. Use a leak test solution or other approved methods for leak testing. Failure to follow recommended safe leak test procedures could result in death or serious injury or equipment or property-only-damage.

To check gas tightness of the safety shut-off valves, turn off the manual valve upstream of the appliance combination control. Remove the 1/8-inch pipe plug on the inlet side of the combination control and connect a manometer to that tapping. Turn the manual valve on to apply pressure to the combination control. Note the pressure reading on the

manometer, then turn the valve off. A loss of pressure indicates a leak. If a leak is detected, use a soap solution to check all threaded connections. If no leak is found, combination control is faulty and must be replaced before putting appliance back in service.

Should maintenance be required, perform the following inspection and service routine:

1. Inspect the area near the unit to be sure that there is no combustible material located within the minimum clearance requirements listed in this manual (see [Table 3, p. 12](#)).

## ⚠ WARNING

### Combustible Materials!

Maintain proper clearance between the unit heat exchanger, vent surfaces and combustible materials. Refer to unit nameplate and installation instructions for proper clearances. Improper clearances could result in a fire hazard. Failure to maintain proper clearances could result in death or serious injury or property damage.

2. Turn off the manual gas valve and electrical power to the gas duct furnace.
3. To clean or replace the main burners, remove the bottom panel and compress the spring by moving the burner toward the manifold. Slide the opposite end of the burner downward from the locating slot while retaining spring is still compressed. Pull the burners away from the heater.
4. With the burners removed, wire brush the inside surfaces of the heat exchanger.
5. Remove any dirt, dust, or other foreign matter from the burners using a wire brush and/or compressed air. Ensure that all parts are unobstructed. Inspect and clean pilot burner if necessary.
6. Reassemble the gas duct furnace by replacing all parts in reverse order.
7. Complete the appropriate unit start-up procedure as given in [“Operation,”](#) p. 26 (see unit lighting instruction plate and the unit nameplate).
8. Check the burner adjustment (see [“Primary Air Shutter Adjustment,”](#) p. 28).
9. Check all gas control valves and pipe connections for leaks.
10. Check the operation of the automatic gas valve by lowering the setting of the thermostat, stopping the operation of the gas duct furnace. The gas valve should close tightly, completely extinguishing the flame on the main burners.
11. Inspect and service the blower section of the system. Check and test the operational functions of all safety devices supplied with your unit.

**Figure 20. Power venter assembly**

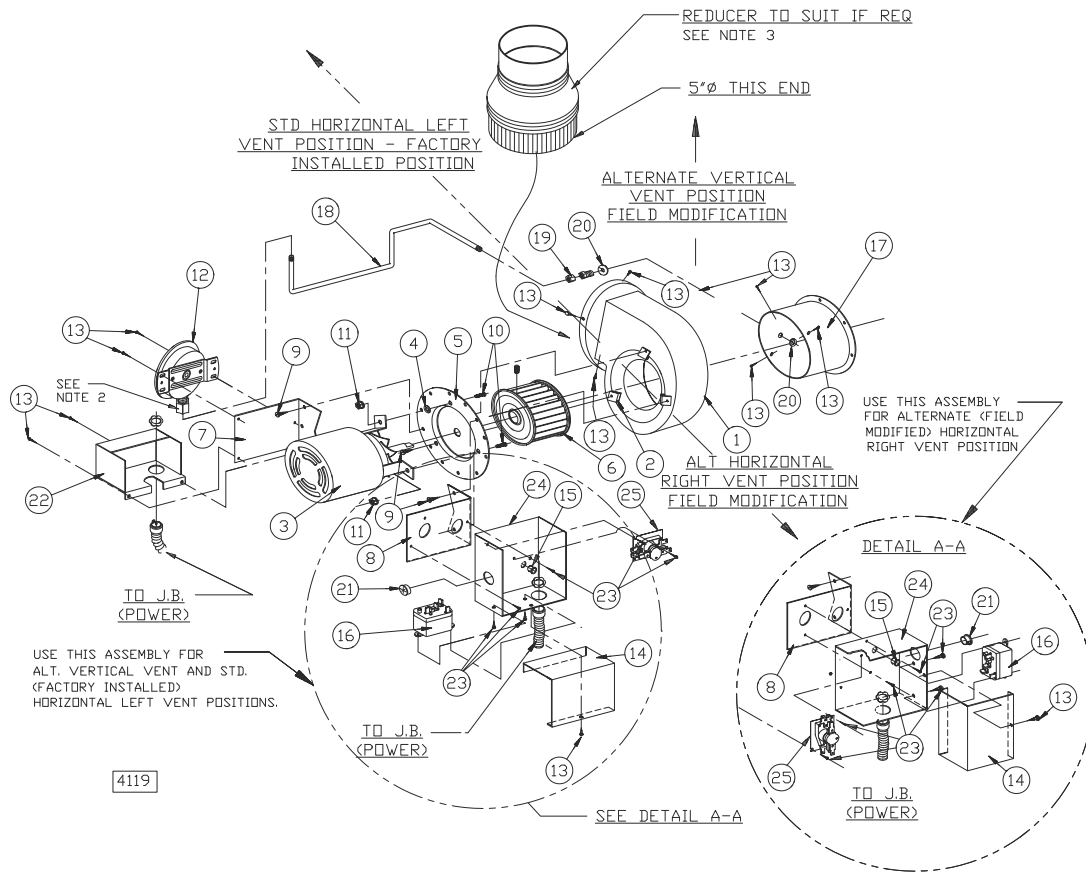

Ref. No.	Description	Ref. No.	Description
1	Blower Housing Assembly	15	Snap Bushing
2	Speed Nut	16	Relay (Motor)
3	Motor	17	Draftor Stack Assembly
4	Washer, Plain	18	Tubing (Aluminum) Formation
5	Plate Adapter	19	Male Connector
6	Blower Wheel (see Note 1)	20	Locknut
7	Mounting Bracket (Pressure Switch)	21	Hole Plug
8	Mounting Bracket (Junction Box)	22	Pressure Switch Cover
9	Screw, S.T.	23	Drill Screw
10	Screw, Machine (L = 3/4")	24	Junction Box Base
11	Nut, Keps (Ext. Lock Washer)	25	Purge Relay
12	Air Pressure Switch		
13	Drill Screw		
14	Junction Box Cover		

**Notes:**

- For item No. 6, use counter-clockwise rotation.
- DO NOT OVERTIGHTEN CELCON NUT! HAND TIGHTEN ONLY! DO NOT USE TOOLS! Approximate 1/3 turn maximum or 8 inch pounds is sufficient from the point where the tube does not slip in or out.
- Flue Sizes:  
 100/175 units: 4" dia. flue outlet Reducer required—to be supplied by installer.  
 200/250 units: 5" dia. flue outlet (no adapter required).  
 300/400 units: 6" dia. flue outlet Increaser required—to be supplied by manufacturer.

## Installation Instructions for Field Replacement of Power Venter Motor

**Important:** This replacement must be performed only by a qualified technician.

**Figure 21. Identification of parts**

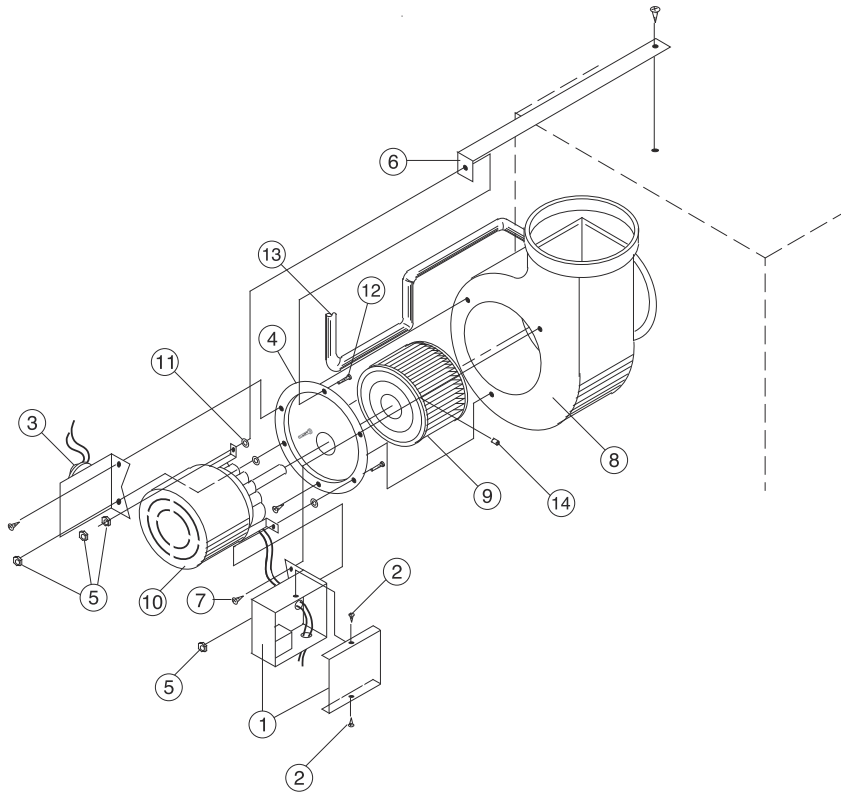

**Note:** All hardware (screws, nuts, washers) that will be removed from the unit will be reused for this motor replacement. **DO NOT LOSE ANY OF THESE PARTS.**

Ref. No.	Description
1	Relay Junction Box/Mounting Bracket Assembly
2	#8 Drill Screws (2 required)
3	Pressure/Mounting Bracket Assembly
4	Mounting Plate Adapter
5	Keeps Nut w/External Tooth Lockwasher (4 required)
6	Motor Support Shipping Bracket
7	Phillips Head Screws (3 required)
8	Power Venter Blower Housing
9	Blower Wheel
10	Motor
11	Space Washers (3 required)
12	Machine Screw (3 required)
13	Sensing Tube
14	Set Screw

### Tools and Parts Needed

Wire Stripper and Crimper; Slotted Head and #2 Phillips Head Screwdriver; 3/8-in. Wrench; 1/8-in. Allen Wrench (long handle); marker; (1) 1/4-in. push on terminal for Wire.

#### Notes:

- Remove the cover from the Relay Junction Box (Item 1) by removing two screws (Item 2) top and bottom. Disconnect both wires from the motor lead ends. One is connected to terminal #4 on the venter relay, and the other is connected with a wire nut to a black wire.
- Remove the sensing tube (Item 3) from the Pressure Switch/Mounting Bracket (Item 3) at motor end only. Separated Combustion Units: Remove both tubes at motor end only—note location.
- Mark locations of the Relay Junction Box and Pressure Switch Mounting Brackets along with the Motor (Item 10) mounts on the Mounting Adapter Plate (Item 4)—using a marker.
- Remove nut (Item 5) that secures the Motor Support Shipping Bracket (Item 6) to the Mounting Adapter

Plate. Pull this bracket away from the Motor Mounting Adapter Plate.

- Remove three phillips head screws (Item 7) on the Motor mounting Adapter Plate. Remove the Motor/Blower Wheel/Adapter Plate assembly from the Power Venter Blower Housing (Item 8).
- Remove the Blower Wheel (Item 9) from the motor shaft by removing the set screw (Item 14) using a 1/8-in. Allen Wrench.
- Remove the three Motor Mounting Nuts (Item 5), Space Washers (Item 11), and Screws (Item 12). Do not lose these parts! Using caution—the motor will disengage from the Mounting Adapter Plate, along with the Relay Junction Box and Pressure Switch Mounting Brackets will also disengage.
- Reverse order to install the new Power Venter Motor.
- TEST FIRE THE UNIT FOR A FEW CYCLES, MAKING SURE THAT THE UNIT IS OPERATING SATISFACTORILY.**



## Maintenance

---

### How to Order Replacement Parts

Please send the following information to your local Parts center; If further assistance is needed, contact the manufacturer's customer service department.

- Model number
- Serial Number
- Part description and Number as shown in the Replacement Parts Catalog.

# Diagnostics

## Troubleshooting

**⚠ WARNING**

**Hazardous Service Procedures!**

The maintenance and troubleshooting procedures recommended in this section of the manual could result in exposure to electrical, mechanical or other potential safety hazards. Always refer to the safety warnings provided throughout this manual concerning these procedures. When possible, disconnect all electrical power including remote disconnect and discharge all energy storing devices such as capacitors before servicing. Follow proper lockout/tagout procedures to ensure the power can not be inadvertently energized. When necessary to work with live electrical components, have a qualified licensed electrician or other individual who has been trained in handling live electrical components perform these tasks. Failure to follow all of the recommended safety warnings provided, could result in death or serious injury.

**Table 8. Troubleshooting guide**

Symptoms	Possible Cause(s)	Corrective Action
A. Flame lifting from burner ports.	<ol style="list-style-type: none"> <li>1. Pressure regulator set too high.</li> <li>2. Defective regulator.</li> <li>3. Burner orifice too large.</li> </ol>	<ol style="list-style-type: none"> <li>1. Reset manifold pressure. Refer to "Operation," p. 26.</li> <li>2. Replace regulator section of combination gas valve or complete valve.</li> <li>3. Check with local gas supplier for proper orifice size and replace. Refer to "Operation," p. 26.</li> </ol>
B. Flame pops back.	<ol style="list-style-type: none"> <li>1. Excessive primary air.</li> <li>2. Burner orifice too small.</li> </ol>	<ol style="list-style-type: none"> <li>1. Close air shutter. Refer to "Operation," p. 26.</li> <li>2. Check with local gas supplier for proper orifice size and replace. Refer to "Operation," p. 26.</li> </ol>
C. Noisy flame.	<ol style="list-style-type: none"> <li>1. Too much primary air.</li> <li>2. Noisy pilot.</li> <li>3. Irregular orifice causing whistle or resonance.</li> <li>4. Excessive gas input.</li> </ol>	<ol style="list-style-type: none"> <li>1. Close air shutter.</li> <li>2. Reduce pilot gas. Refer to "Operation," p. 26.</li> <li>3. Replace orifice.</li> <li>4. Reset manifold pressure. Refer to "Operation," p. 26; Replace regulator section of combination gas valve or complete valve; or check with local gas supplier for proper orifice size and replace. Refer to "Operation," p. 26.</li> </ol>
D. Yellow tip flame (some yellow tipping on propane gas is permissible).	<ol style="list-style-type: none"> <li>1. Insufficient primary air.</li> <li>2. Clogged burner ports.</li> <li>3. Misaligned orifices.</li> <li>4. Clogged draft hood.</li> <li>5. Air shutter.</li> <li>6. Insufficient combustion air.</li> </ol>	<ol style="list-style-type: none"> <li>1. Open air shutters. Refer to "Operation," p. 26.</li> <li>2. Clean main burner ports.</li> <li>3. Replace manifold assembly.</li> <li>4. Clean draft hood.</li> <li>5. Check for dust or lint at air mixer opening and around the air shutter.</li> <li>6. Check for obstruction in combustion air inlet cap and piping; see "Installation: Piping," p. 16.</li> </ol>
E. Floating flame.	<ol style="list-style-type: none"> <li>1. Blocked venting.</li> <li>2. Insufficient combustion air.</li> <li>3. Blocked heat exchanger.</li> <li>4. Air leak into combustion chamber or draft hood.</li> </ol>	<ol style="list-style-type: none"> <li>1. Clean flue. Refer to "Installation: Piping," p. 16.</li> <li>2. Check for obstruction in combustion air inlet cap and piping; see "Installation: Piping," p. 16.</li> <li>3. Clean heater.</li> <li>4. Determine cause and repair accordingly.</li> </ol>

## Diagnostics

**Table 8. Troubleshooting guide (continued)**

Symptoms	Possible Cause(s)	Corrective Action
F. Gas Odor.	<b>1. Shut off gas immediately!</b>	<b>1. Inspect all gas piping and repair.</b>
	2. Blocked heat exchanger/venting.	2. Clean heat exchanger/flue.
	3. Drafts around heater.	3. Eliminate drafts. Refer to " <a href="#">Installation: Mechanical</a> ," p. 12.
	4. Negative pressure in building.	4. See " <a href="#">Installation: Piping</a> ," p. 16.
	5. Blocked draft hood.	5. Clean draft hood.
G. Delayed ignition.	1. Excessive primary air.	1. Close air shutter. Refer to " <a href="#">Operation</a> ," p. 26.
	2. Main burner ports clogged near pilot.	2. Clean main burner ports.
	3. Pressure regulator set too low.	3. Reset manifold pressure. Refer to " <a href="#">Operation</a> ," p. 26.
	4. Pilot decreases in size when main burners come on.	4. Supply piping is inadequately sized. Refer to " <a href="#">Installation: Piping</a> ," p. 16.
	5. Pilot flame too small.	5. Clean pilot orifice. Refer to " <a href="#">Operation</a> ," p. 26.
	6. Drafts around venter.	6. Eliminate drafts. Refer to " <a href="#">Installation: Mechanical</a> ," p. 12.
	7. Improper venting.	7. Refer to " <a href="#">Installation: Piping</a> ," p. 16.
H. Failure to ignite.	1. Main gas valve off.	1. Open all manual gas valves.
	2. Lack of power at unit.	2. Replace fuse or turn on power supply.
	3. Thermostat not calling for heat.	3. Turn up thermostat.
	4. Defective limit switch.	4. Check limit switch with continuity tester. If open, replace high limit switch.
	5. Improper thermostat or transformer wiring.	5. Check wiring per diagrams.
	6. Defective gas valve.	6. Replace gas valve.
	7. Defective thermostat.	7. Check thermostat and replace if defective.
	8. Defective transformer.	8. Be sure 115 volts is supplied to the transformer primary, then check for 24 volts at secondary terminal before replacing.
	9. Loose wiring.	9. Check and tighten all wiring connections per diagrams.
	10. Defective ignition control.	10. Replace, if necessary. Also see <a href="#">U</a> , <a href="#">V</a> , and <a href="#">W</a> symptoms.
I. Condensation of water vapor.	1. Condensation of water vapor.	1. Refer to " <a href="#">Installation: Venting</a> ," p. 18.
J. Burner won't turn off.	1. Poor thermostat location.	1. Relocate thermostat away from drafts.
	2. Defective thermostat.	2. Replace thermostat.
	3. Improper thermostat or transformer wiring at gas valve.	3. Check wiring per diagrams.
	4. Short circuit.	4. Check operation at valve. Check for short (such as staples piercing thermostat wiring), and correct.
	5. Defective or sticking gas valve.	5. Replace gas valve.
	6. Excessive gas supply pressure.	6. Refer to " <a href="#">Installation: Piping</a> ," p. 16.
K. Rapid burner cycling.	1. Loose wiring connections at gas valve or thermostat.	1. Tighten all connections.
	2. Excessive thermostat heat anticipator.	2. Adjust thermostat for longer cycles. Refer to " <a href="#">Installation: Electrical</a> ," p. 24.
	3. Unit cycling on high limit.	3. Check for proper air supply across heat exchanger.
	4. Poor thermostat location.	4. Relocate thermostat. (Do not mount thermostat on unit).
	5. Draft on pilot.	5. Eliminate drafts. Refer to " <a href="#">Installation: Mechanical</a> ," p. 12.
	6. Defective ignitor control.	6. Replace ignitor.
	7. Defective high limit.	7. Jumper limit switch terminals 1 and 2. If burner operates normally, replace switch.
L. Noisy power venter.	1. Power venter wheel loose.	1. Replace or tighten.
	2. Power venter wheel dirty.	2. Clean power venter wheel.
	3. Power venter wheel rubbing housing.	3. Realign power venter wheel.
	4. Bearings are dry.	4. Oil bearings on power venter motor. (Refer to label on motor.)
M. Pilot will not light or will not stay lit.	1. Main gas valve off.	1. Open all manual gas valves.



**Table 8. Troubleshooting guide (continued)**

<b>Symptoms</b>	<b>Possible Cause(s)</b>	<b>Corrective Action</b>
	2. Pilot adjustment screw turned too low on combination main gas valve.	2. Increase size of pilot flame. Refer to <a href="#">"Operation," p. 26.</a>
	3. Air in gas line.	3. Purge air from line.
	4. Incorrect lighting procedure.	4. Follow lighting instruction label adjacent to gas valve.
	5. Dirt in pilot orifice.	5. Remove pilot orifice. Clean with compressed air or solvent. (Do not ream.)
	6. Extremely high or low gas pressure.	6. Refer to <a href="#">"Operation," p. 26.</a>
	7. Drafts around unit.	7. Eliminate drafts. Refer to <a href="#">"Installation: Mechanical," p. 12.</a>
	8. Pilot valve not opening (faulty wiring).	8. Inspect and correct all wiring.
	9. No spark (faulty wiring).	9. Inspect and correct ignition system wiring. See symptoms <a href="#">U</a> , <a href="#">V</a> , and <a href="#">W</a> .
	10. Defective gas valve.	10. Replace gas valve.
N. Power venter will not run.	1. Loose wiring.	1. Check and tighten all wiring connections per diagrams. Thermostat wires tagged "W" and "G" must be connected together (unless special thermostats are used; if so, see thermostat wiring diagram, <a href="#">"Electrical Connections," p. 24.</a> )
	2. Defective motor overload protector or defective motor.	2. Replace motor.
	3. Defective power venter relay.	3. Check for 24V across terminals on fan relay. If 24V is present, jumper terminals numbered 2 and 4. If motor runs, the fan relay is defective and must be replaced. If 24V is not present, check wiring per diagrams.
O. Power venter motor turns on and off while burners are operating.	1. Fan relay heater element improperly wired.	1. Be sure venter relay heater terminals are connected per diagrams.
	2. Defective venter relay switch.	2. Replace venter relay.
	3. Motor protector cycling on and off.	3. Check motor amps against motor name plate rating, check voltage, replace venter relay motor if defective.
	4. Motor not properly oiled.	4. Refer to label on motor.
P. Power venter motor will not stop.	1. Improperly wired venter relay.	1. Check all wiring.
	2. Main burners not lighting while thermostat calls for heat.	2. Refer to <a href="#">H</a> and <a href="#">N</a> symptoms.
	3. Defective venter relay.	3. Replace venter relay.
Q. Not enough heat.	1. Incorrect gas input.	1. Refer to <a href="#">"Operation," p. 26.</a>
	2. Heater undersized.	2. This is especially true when the heated space is enlarged. Have the heat loss calculated and compare to the heater output (80 percent of input). Your gas supplier or installer can furnish this information. If heater is undersized, add additional heaters.
	3. Thermostat malfunction.	3. Replace thermostat.
	4. Heater cycling on high limit.	4. Check air movement through heat exchanger. Check voltage to fan motor. Clean power venter motor.
	5. Check outside dampers if used.	5. Adjust dampers accordingly.
R. Too much heat.	1. Thermostat malfunction.	1. Replace thermostat.
	2. Heater runs continuously.	2. Check wiring per diagrams; check operation at valve. Look for short (such as staples piercing thermostat wiring), and correct; replace gas valve. Refer to <a href="#">"Operation," p. 26.</a>
S. Cold air is delivered on start up.	1. Fan relay heater element improperly wired.	1. Be sure fan relay heater terminals are connected per diagrams.
T. Cold air is delivered during heater operation.	1. Incorrect manifold pressure or input.	1. Refer to <a href="#">"Operation," p. 26.</a>
	2. Voltage to unit too high.	2. Check motor voltage with fan running. Should be 115 volts AC.
	3. Air throughput too high.	3. Refer to <a href="#">"Operation," p. 26.</a>

## Diagnosics

**Table 8. Troubleshooting guide (continued)**

<b>Symptoms</b>	<b>Possible Cause(s)</b>	<b>Corrective Action</b>
U. No Spark.	<ol style="list-style-type: none"> <li>1. Thermostat not calling for heat.</li> <li>2. No low voltage.</li> <li>3. Spark gap closed or too wide.</li> <li>4. Broken or cracked ceramic on spark electrode.</li> </ol>	<ol style="list-style-type: none"> <li>1. Close thermostat contacts.</li> <li>2. Check for 24V across 24V terminals of S8600.</li> <li>3. Set gap to 0.1.</li> <li>4. Replace pilot assembly.</li> </ol>
V. Spark present but pilot does not light.	<ol style="list-style-type: none"> <li>1. Loose S8600 connections.</li> <li>2. Improper gas pressure.</li> <li>3. Is spark in pilot gas stream?</li> <li>4. No pilot gas — do not use match to test - presence of gas is easily detected by the odor.</li> </ol>	<ol style="list-style-type: none"> <li>1. Check all connections, term. PV feeds 24V to pilot valve.</li> <li>2. Check pressure—pressure that is either too high or too low may cause a problem.</li> <li>3. Spark should arc from electrode.</li> <li>4. Check pilot line for kinks. Ensure there are no drafts.</li> </ol>
W. Pilot lights — Main valve does not energize.	<ol style="list-style-type: none"> <li>1. Loose S8600 connections.</li> <li>2. Cracked or broken sensor ceramic.</li> <li>3. Check sensor/spark lead for continuity.</li> <li>4. Measure 24 volts from term. MV to term. MV/PV.</li> </ol>	<ol style="list-style-type: none"> <li>1. Check connections-term. MV feeds main valve.</li> <li>2. Replace pilot assembly.</li> <li>3. Replace if needed.</li> <li>4. If present, replace main valve; if not, replace S8600 Igniter.</li> </ol>
X. Hi-Limit switch tripping.	<ol style="list-style-type: none"> <li>1. Unit is overfiring.</li> <li>2. Air flow too low.</li> <li>3. Defective switch.</li> </ol>	<ol style="list-style-type: none"> <li>1. Manifold pressure too high; adjust. Burner orifices may be too large: verify/replace if required.</li> <li>2. Increase air flow; check fan size. Check for proper voltage.</li> <li>3. Replace.</li> </ol>

# Wiring Diagrams

**Figure 22. Standard wiring diagram for unit with S8600 ignition system**

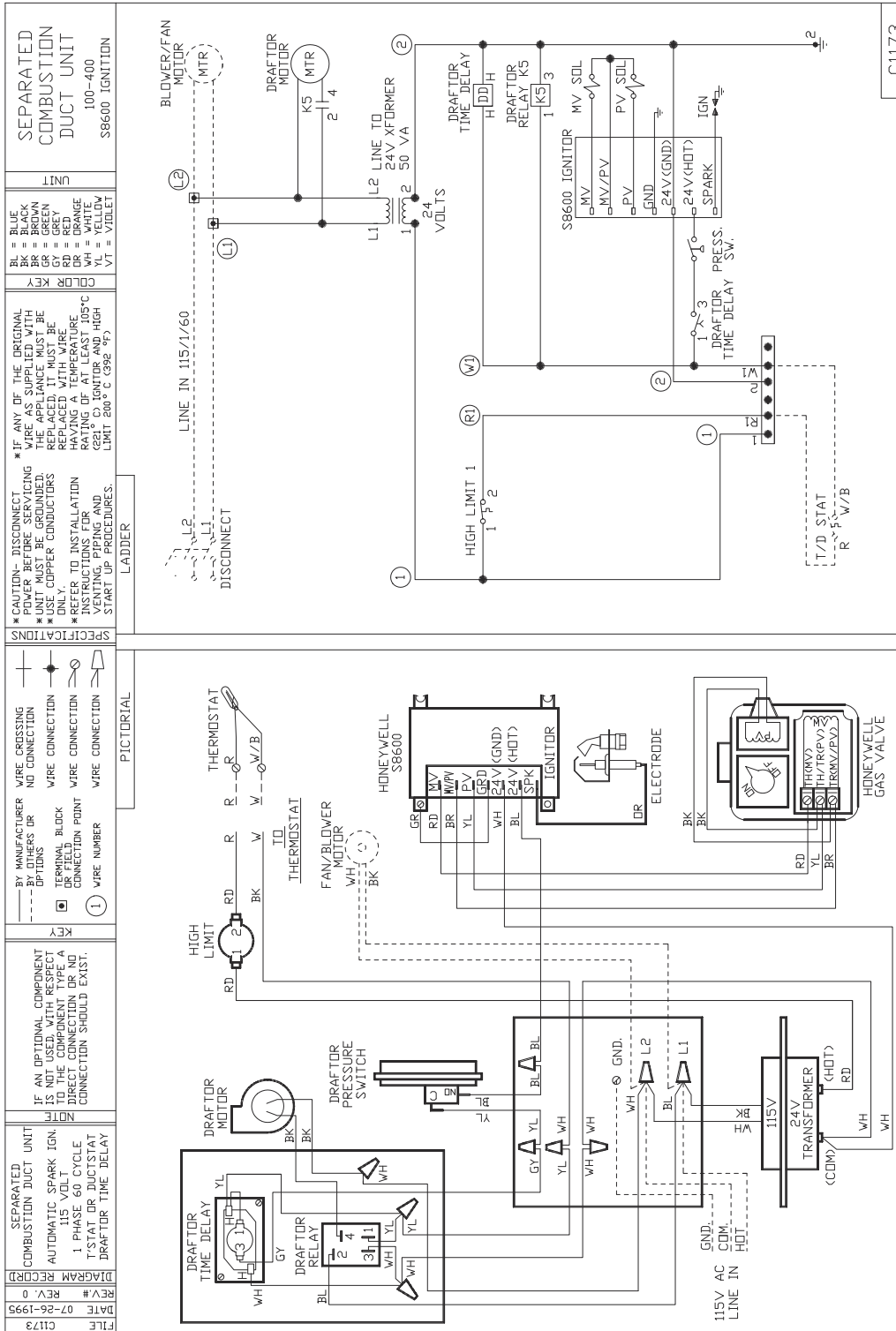

**Figure 23. Standard wiring diagram for unit with G770 ignition system**

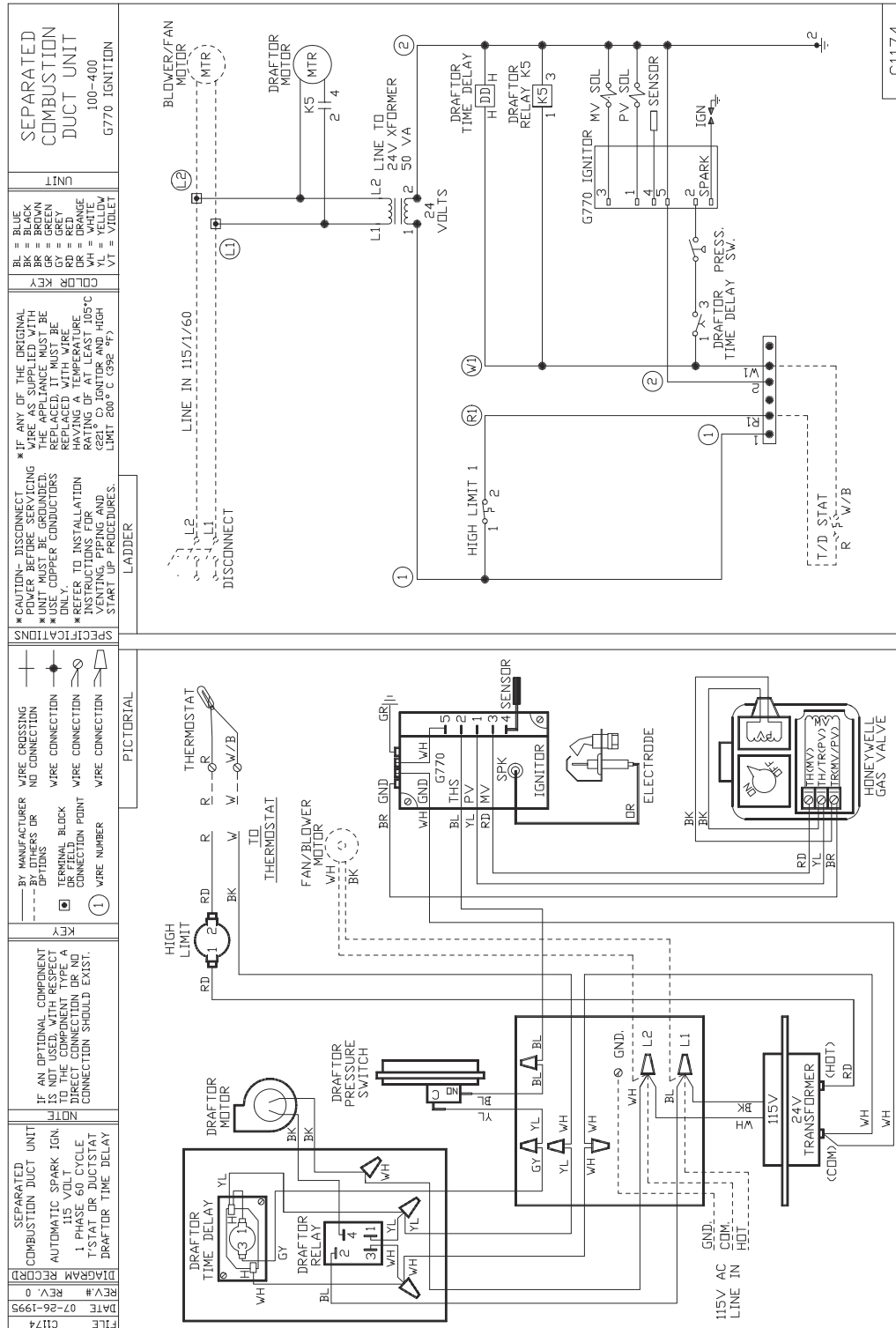



Trane optimizes the performance of homes and buildings around the world. A business of Ingersoll Rand, the leader in creating and sustaining safe, comfortable and energy efficient environments, Trane offers a broad portfolio of advanced controls and HVAC systems, comprehensive building services, and parts. For more information, visit [www.Trane.com](http://www.Trane.com).

Trane has a policy of continuous product and product data improvement and reserves the right to change design and specifications without notice.

© 2012 Trane All rights reserved  
GMND-SVX01B-EN 16 Mar 2012  
Supersedes GMND-SVX01A-EN (01 Mar 2010)

We are committed to using environmentally  
conscious print practices that reduce waste.

