

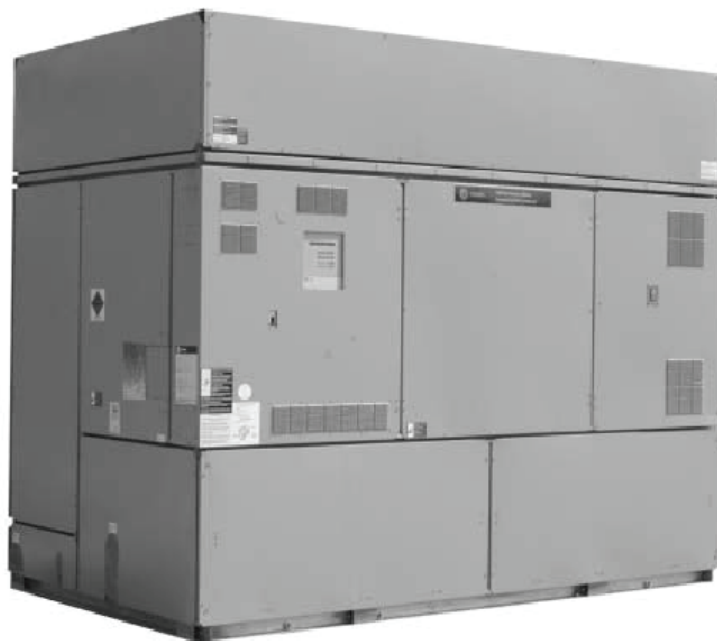

Installation, Operation, and Maintenance

Intellipak™
Commercial Self-Contained
Signature Series
20-110 Tons



⚠ SAFETY WARNING

Only qualified personnel should install and service the equipment. The installation, starting up, and servicing of heating, ventilating, and air-conditioning equipment can be hazardous and requires specific knowledge and training. Improperly installed, adjusted or altered equipment by an unqualified person could result in death or serious injury. When working on the equipment, observe all precautions in the literature and on the tags, stickers, and labels that are attached to the equipment.



Introduction

Read this manual thoroughly before operating or servicing this unit.

Warnings, Cautions, and Notices

Safety advisories appear throughout this manual as required. Your personal safety and the proper operation of this machine depend upon the strict observance of these precautions.

The three types of advisories are defined as follows:

⚠ WARNING Indicates a potentially hazardous situation which, if not avoided, could result in death or serious injury.

⚠ CAUTION Indicates a potentially hazardous situation which, if not avoided, could result in minor or moderate injury. It could also be used to alert against unsafe practices.

NOTICE Indicates a situation that could result in equipment or property-damage only accidents.

Important Environmental Concerns

Scientific research has shown that certain man-made chemicals can affect the earth's naturally occurring stratospheric ozone layer when released to the atmosphere. In particular, several of the identified chemicals that may affect the ozone layer are refrigerants that contain Chlorine, Fluorine and Carbon (CFCs) and those containing Hydrogen, Chlorine, Fluorine and Carbon (HCFCs). Not all refrigerants containing these compounds have the same potential impact to the environment. Trane advocates the responsible handling of all refrigerants-including industry replacements for CFCs such as HCFCs and HFCs.

Important Responsible Refrigerant Practices

Trane believes that responsible refrigerant practices are important to the environment, our customers, and the air conditioning industry. All technicians who handle refrigerants must be certified. The Federal Clean Air Act (Section 608) sets forth the requirements for handling, reclaiming, recovering and recycling of certain refrigerants and the equipment that is used in these service procedures. In addition, some states or municipalities may have additional requirements that must also be adhered to for responsible management of refrigerants. Know the applicable laws and follow them.

⚠ WARNING

Proper Field Wiring and Grounding Required!

Failure to follow code could result in death or serious injury. All field wiring **MUST** be performed by qualified personnel. Improperly installed and grounded field wiring poses **FIRE** and **ELECTROCUTION** hazards. To avoid these hazards, you **MUST** follow requirements for field wiring installation and grounding as described in NEC and your local/state electrical codes.

⚠ WARNING

Personal Protective Equipment (PPE) Required!

Installing/servicing this unit could result in exposure to electrical, mechanical and chemical hazards.

- Before installing/servicing this unit, technicians **MUST** put on all PPE required for the work being undertaken (Examples; cut resistant gloves/sleeves, butyl gloves, safety glasses, hard hat/bump cap, fall protection, electrical PPE and arc flash clothing). **ALWAYS** refer to appropriate Material Safety Data Sheets (MSDS)/Safety Data Sheets (SDS) and OSHA guidelines for proper PPE.
- When working with or around hazardous chemicals, **ALWAYS** refer to the appropriate MSDS/SDS and OSHA/GHS (Global Harmonized System of Classification and Labelling of Chemicals) guidelines for information on allowable personal exposure levels, proper respiratory protection and handling instructions.
- If there is a risk of energized electrical contact, arc, or flash, technicians **MUST** put on all PPE in accordance with OSHA, NFPA 70E, or other country-specific requirements for arc flash protection, **PRIOR** to servicing the unit. **NEVER PERFORM ANY SWITCHING, DISCONNECTING, OR VOLTAGE TESTING WITHOUT PROPER ELECTRICAL PPE AND ARC FLASH CLOTHING. ENSURE ELECTRICAL METERS AND EQUIPMENT ARE PROPERLY RATED FOR INTENDED VOLTAGE.**

Failure to follow instructions could result in death or serious injury.

⚠ WARNING**Refrigerant under High Pressure!**

System contains oil and refrigerant under high pressure. Recover refrigerant to relieve pressure before opening the system. See unit nameplate for refrigerant type. Do not use non-approved refrigerants, refrigerant substitutes, or refrigerant additives. Failure to recover refrigerant to relieve pressure or the use of non-approved refrigerants, refrigerant substitutes, or refrigerant additives could result in an explosion which could result in death or serious injury or equipment damage.

⚠ WARNING**Hazardous Voltage w/Capacitors!**

Disconnect all electric power, including remote disconnects and discharge all motor start/run capacitors before servicing. Follow proper lockout/tagout procedures to ensure the power cannot be inadvertently energized. For variable frequency drives or other energy storing components provided by Trane or others, refer to the appropriate manufacturer's literature for allowable waiting periods for discharge of capacitors. Verify with an appropriate voltmeter that all capacitors have discharged. Failure to disconnect power and discharge capacitors before servicing could result in death or serious injury.

For additional information regarding the safe discharge of capacitors, see PROD-SVB06A-EN

NOTICE:**Use Copper Conductors Only!**

Unit terminals are not designed to accept other types of conductors. Failure to use copper conductors could result in equipment damage.

Introduction

Overview

Note: One copy of this document ships inside the control panel of each unit and is customer property. It must be retained by the unit's maintenance personnel.

This booklet describes proper installation, operation, and maintenance procedures for air cooled systems. By carefully reviewing the information within this manual and following the instructions, the risk of improper operation and/or component damage will be minimized. It is important that periodic maintenance be performed to help assure trouble free operation. A maintenance schedule is provided at the end of this manual. Should equipment failure occur, contact a qualified service organization with qualified, experienced HVAC technicians to properly diagnose and repair this equipment.

This manual covers installation, operation and maintenance of 20-110 ton Signature Series Commercial Self Contained products with R-410A refrigerant.

R-410A Compressors

- Use crank case heaters which must be energized 24 hours prior to compressor start.
- Contain POE oil which readily absorbs potentially damaging moisture from air.
- Control box includes a phase monitor to detect phase loss, line voltage imbalance and reversal.

Refer to previous IOM versions for R-407C and R-22 units, or contact your local Trane representative.

Refer to the appropriate IOM for air-cooled condenser CXRC-SVX01 and programming Intellipak controls PKG-SVP01.

Copyright

This document and the information in it are the property of Trane, and may not be used or reproduced in whole or in part without written permission. Trane reserves the right to revise this publication at any time, and to make changes to its content without obligation to notify any person of such revision or change.

Trademarks

Trane, Trane 3-D, Intellipak, Integrated Comfort, Traq, TOPSS, Frostat and the Trane logo are trademarks of Trane in the United States and other countries.

All trademarks referenced in this document are the trademarks of their respective owners.

Revision History

SCXF-SVX01K-EN (02 Jul 2014)

Update for fan wheel project.

SCXF-SVX01J-EN (23 Oct 2012)

Updated fan motor FLA data.



Table of Contents

Warnings, Cautions and Notices	2	Static Pressure Transducer Installation (VAV units only)	39
Introduction	3	Standard with All IntelliPak Units	40
Model Number Descriptions	6	Zone Sensor Options for IntelliPak™ Control Units	40
Self-Contained Ship-With Accessory Model Number	8	CV and VAV Unit Zone Sensor Options	41
Remote Air-Cooled Condenser Model Number Description	8	Integrated Comfort™ Systems Sensors for CV and VAV Applications	41
General Data	9	Zone Sensor Installation	42
Signature Series Self-Contained Unit Components	9	Programmable Zone Sensors	43
Unit Nameplate	10	Time Clock Option	44
General Data	11	Remote Human Interface Panel Installation	45
Pre-Installation	17	Mounting the Remote Human Interface (RHI) Panel	46
Receiving	17	Wiring the Remote Human Interface	48
Contractor Installation Responsibilities	17	Connecting to Tracer Summit	49
Unpackaging	18	Programming the Time Clock Option	49
Dimensions & Weights	19	Operating	51
Airside Economizer	26	Control Sequences of Operation	51
Service Clearances	27	Unoccupied Sequence of Operation	51
Installation - Mechanical	28	Occupied Sequence	52
Unit Handling Procedure	28	Thermostatic Expansion Valve	54
Installation Preparation	29	Compressors	54
Unit Vibration Isolator Option	29	Waterside Components	56
Duct Connections	30	Unit Airside Components	58
Plenum	30	Controls	62
Airside Economizer Installation	31	Points List	62
Water Piping	32	RTM Module	62
Condenser Connections	32	GBAS Module	62
Condensate Drain Connections	32	ECEM Module	62
General Waterside Recommendations	32	Tracer /LCI-I option	62
Water Piping Verification	33	Constant Volume (CV)	62
Hydronic Coil Installation	33	Variable Air Volume (VAV)	63
Refrigerant System	33	BCI-I option	63
Interconnecting Piping	34	Phase Monitor	64
Preliminary Refrigerant Charging	35	Unit Control Components	64
Installation - Electrical	37	RTM Module Board - Standard on all Units	64
Unit Wiring Diagrams	37	Compressor Module (MCM) - Standard on all Units	66
Supply Power Wiring	37		
Selection Procedures	38		

Human Interface Module - Standard on all Units	66	Brazing Procedures	85
Remote Human Interface Module Option	66	System Evacuation Procedures	86
Waterside Module - Standard on all water-cooled units	66	Components	88
Heat Module	66	Coil Fin Cleaning	89
Ventilation Override Module (VOM) Option 66		Piping Components	91
LonTalk® Communications Interface (LCI-I) Module	67	Maintenance Periodic Checklists	91
BACnet® Communications Interface (BCI-I) Module	68	Diagnostics	93
Exhaust/Comparative Enthalpy (ECEM) Module	68	Troubleshooting	93
Ventilation Control Module (VCM)	68	System Checks	93
Generic Building Automation System Module Option	69	Diagnostics	93
Input Devices and System Functions	70	Wiring Diagrams	102
Pre-Start	73		
Pre-Start Checklist	73		
Start-Up	75		
Final Refrigerant Charge	76		
Start-up Procedure	76		
Startup Log	77		
Maintenance	79		
Service Access	79		
Variable Frequency Drive (VFD)	79		
Air Filters	79		
Inspecting and Cleaning the Drain Pan ..	80		
Inspecting and Cleaning the Fan	81		
Supply Fan	81		
Fan Drive	81		
Fan Bearings	82		
Fan Belt Tension	82		
Adjusting Belt Tension	83		
Compressors	84		
Scroll Compressor Failure Diagnosis and Replacement	84		
40 Ton Air-Cooled Compressor Suction Restrictor Replacement	84		
Refrigerant System	84		
Refrigerant Leak Test Procedure	84		



Model Number Descriptions

Self-Contained

Digit 1 - Unit Model

S = Self Contained

Digit 2 - Unit Type

C = Commercial
I = Industrial

Digit 3 - Condenser Medium

W = Water-cooled
R = Air-cooled

Digit 4 - Development Sequence

F = Signature Series

Digit 5 - Refrigerant Circuit Configuration

U = Standard Capacity
V = High Capacity

Digit 6, 7 - Unit Nominal Capacity

20 = 20 tons (water or air)
22 = 22 tons (water only)
25 = 25 tons (water or air)
29 = 29 tons (water or air)
30 = 30 tons (air only)
32 = 32 tons (water only)
35 = 35 tons (water or air)
38 = 38 tons (water only)
40 = 40 tons (air only)
42 = 42 tons (water only)
46 = 46 tons (water only)
50 = 50 tons (air only)
52 = 52 tons (water only)
58 = 58 tons (water only)
60 = 60 tons (air only)
65 = 65 tons (water only)
72 = 72 tons (water only)
80 = 80 tons (water only)
90 = 90 tons (water only)
C0 = 100 tons (water only)
C1 = 110 tons (water only)

Digit 8 - Unit Voltage

6 = 200 volt/60 hz/3 ph
4 = 460 volt/60 hz/3 ph
5 = 575 volt/60 hz/3 ph

Digit 9 - Air Volume/Temp Control

2 = VFD and supply air temp ctrl
3 = VFD w/ bypass and supply air temp ctrl
4 = Constant volume, zone temp cool only
5 = Constant volume, w/ zone temp heat/cool
6 = Constant volume and supply air temp ctrl

Digit 10, 11 - Design Sequence

** = Factory Assigned

Digit 12 - Unit Construction

A = Vertical Discharge
B = Vertical Discharge With Double Wall

Digit 13 - Flexible Horizontal Discharge Plenum Type

B = STD plenum w/ factory-cut holes
C = Low plenum w/ factory-cut holes
E = Std plenum w/ field-cut holes
F = Low plenum w/ field-cut holes
H = STD plenum double wall w/ field-cut holes
J = Low plenum double wall w/ field-cut holes
K = Extended height plenum w/factory-cut holes, ship separate
L = STD plenum w/factory-cut holes, ship separate
M = Low plenum w/factory-cut holes, ship separate
N = Extended height plenum w/field-cut holes, ship separate
P = STD plenum w/field-cut holes, ship separate
R = Low plenum w/field-cut holes, ship separate
T = Extended height double-wall plenum w/ field-cut holes, ship separate
U = STD double-wall plenum w/field-cut holes, ship separate
V = Low double-wall plenum w/field-cut holes, ship separate
W = STD double-wall (perf) plenum w/field-cut holes (90-110 ton only)
X = Low double-wall (perf) plenum w/field-cut holes (90-110 ton only)
Y = Extended height double-wall (perf) plenum w/field-cut holes, ship separate (90-110 ton only)
0 = None

Digit 14 - Motor Type

2 = ODP motor
3 = TEFC motor

Digit 15, 16 - Motor HP

05 = 5 hp
07 = 7.5 hp
10 = 10 hp
15 = 15 hp
20 = 20 hp
25 = 25 hp
30 = 30 hp
40 = 40 hp
50 = 50 hp (400V, 460V, 575V only)
60 = 60 hp (90-110 ton only)

Digit 17, 18, 19 - Fan rpm

040 = 400 rpm
045 = 450 rpm
050 = 500 rpm
055 = 550 rpm
060 = 600 rpm
065 = 650 rpm
070 = 700 rpm
075 = 750 rpm
080 = 800 rpm
085 = 850 rpm
090 = 900 rpm
095 = 950 rpm
100 = 1000 rpm
105 = 1050 rpm
110 = 1100 rpm
115 = 1150 rpm
120 = 1200 rpm
125 = 1250 rpm
130 = 1300 rpm
135 = 1350 rpm

Digit 20 - Heating Type

A = Steam coil
B = Hot water coil
C = Electric heat, 1 stage
D = Electric Heat (2 Stage)
F = Hydronic heat ctrl interface
G = Elec. heat ctrl interface, 1 stage
H = Elec. heat ctrl interface, 2-stage (90-110 ton only)
J = Elec. heat ctrl interface, 3 stage (90-110 ton only)
K = Steam coil ship separate, LH
L = Hot water coil ship separate, LH
T = Hot water coil, high capacity, LH
U = Hot water coil, high capacity, LH, ship separate
0 = None

Digit 21 - Unit Isolators

A = Isopads
B = Spring isolators
0 = None

Digit 22 - Unit Finish

1 = Paint - Slate Gray
2 = Protective coating
3 = Protective coating w/ finish coat

Digit 23 - Supply Fan Options

0 = Standard fan
1 = Low cfm fan

Digit 24 - Unit Connection

1 = Disconnect switch
2 = Terminal block
3 = Dual point power (2 blocks)

Model Number Descriptions

Digit 25 - Industrial Options

A = Protective coating evaporator coil
 B = Silver solder
 C = Stainless steel screws
 D = A and B
 E = A and C
 F = B and C
 G = A, B, and C
 0 = none

Digit 26 - Drain Pan Type

A = Galvanized sloped
 B = Stainless steel sloped

Digit 27 - Waterside Economizer

A = Mechanical clean full capacity (4-row)
 B = Mechanical clean low capacity (2-row)
 C = Chemical clean full capacity (4-row)
 D = Chemical clean low capacity (2-row)
 0 = None

Digit 28 - Ventilation Control

B = Airside econ w/Traq damper, top O/A
 C = Airside econ w/ std damper, top O/A
 E = Airside econ w/Traq damper & comparative enthalpy, top O/A
 F = Airside econ w/ std damper & comparative enthalpy, top O/A
 H = 2-position damper ventilation interface
 J = Airside economizer interface
 K = Airside economizer interface w/ comparative enthalpy

Digit 29 - Water Piping

D = Left hand basic piping
 F = Left hand Intermediate piping
 K = Left hand basic w/ flow switch
 M = Left hand intermediate w/ flow switch
 0 = None

Digit 30 - Condenser Tube Type

A = Standard condenser tubes
 B = 90/10 CuNi condenser tubes
 0 = None (air-cooled only)

Digit 31 - Compressor Service Valves

1 = With service valves
 0 = None

Digit 32 - Miscellaneous System Control

1 = Timeclock
 2 = Interface For remote HI (IPCB)
 3 = Dirty filter switch
 4 = 1 and 2
 5 = 1 and 3
 6 = 2 and 3
 7 = 1, 2 and 3
 0 = None

Digit 33 - Control Interface Options

A = Generic BAS Module; 0-5 VDC (GBAS)
 B = Ventilation Override Module (VOM)
 D = Remote Human Interface (RHI)
 G = GBAS and VOM
 H = GBAS and RHI
 J = VOM and RHI
 M = GBAS, VOM, and RHI
 N = BACnet Communications Interface (BCI)
 P = BCI and GBAS
 Q = BCI and VOM
 R = BCI and RHI
 T = BCI and GBAS and VOM
 U = BCI and GBAS and RHI
 V = BCI and VOM and RHI
 W = BCI and GBAS and VOM and RHI
 0 = None
 1 = Lontalk Comm5 Interface (LCI)
 2 = LCI and GBAS
 3 = LCI and VOM
 4 = LCI and RHI
 5 = LCI and GBAS and VOM
 6 = LCI and GBAS and RHI
 7 = LCI and VOM and RHI
 8 = LCI and GBAS and VOM and RHI

Digit 34 - Agency

T = UL agency listing
 0 = None

Digit 35 - Filter Type

1 = 2" T/A w/ 2" rack
 2 = 2" med. eff. T/A w/ 2" rack
 3 = 4" bolt-on rack w/ 2" med eff. filter
 4 = 6" rack w/ 2" construction T/A pre-filter & 4" filter space
 5 = 6" rack w/ 2" med. eff. T/A pre-filter & 4" filter space

Digit 36 - Miscellaneous Control Option

A = Low entering air temp. protect device (LEATPD)
 B = High duct temp t-stat, ship separate
 C = Plenum high static switch, ship separate
 E = A and B
 F = A and C
 H = B and C
 L = A, B, and C
 0 = None



Model Number Descriptions

Self-Contained Ship- With Accessory Model Number

Digit 1 - Parts/Accessories

P = parts/accessories

Digit 2 - Unit Model

S = self-contained

Digit 3 - Shipment

W = with unit

Digit 4 - Development Sequence

F = signature series

G = modular series

Digit 5 - Sensors and Other Accessories

S = sensors

Digit 6 - Sensors and Thermostats (Field Installed)

A = BAYSENS077 - zone temp only
(CV and VAV)

B = BAYSENS073- zone temp with
timed override button
(CV and VAV)

C = BAYSENS074 - zone temp with
timed override button, setpoint
dial (CV and VAV)

E = BAYSENS108 - CV zone sensor
-dual setpoint, man/auto
changeover

F = BAYSENS110 - CV zone sensor-
dual setpoint, man/auto
changeover w, indicator lights

G = BAYSENS119 - CV/VAV program-
mable night setback Sensor

H = BAYSENS021 - VAV zone sensor
with indicator lights

L = outside air temperature sensor
kit

M = outside air humidity sensor kit
0 = none

Digit 7 - Mixed Air Temperature Protection Kit (Field Installed)

1 = mixed air temperature protection
kit

0 = none

Digit 8 - Carbon Dioxide Sensor (Field Installed)

1 = carbon dioxide sensor kit

0 = none

Digit 9 - Future Option

0 = none

Digits 10, 11 - Design Sequence

** = Factory Assigned

Remote Air-Cooled Condenser Model Number Description

Digit 1 - Unit Model

C = Condenser

Digit 2 - Unit Type

C = Commercial

I = Industrial

Digit 3 - Condenser Medium

R = Remote

Digit 4 - Development Sequence

C = C

Digit 5, 6, 7 - Nominal Capacity

020 = 20 tons

029 = 29 tons

035 = 35 tons

040 = 40 tons

050 = 50 tons

060 = 60 tons

Digit 8 - Unit Voltage

4 = 460 volt/60 hz/3 ph

5 = 575 volt/60 hz/3 ph

6 = 200 volt/60 hz/3 ph

Digit 9 - Control Option

0 = No low ambient damper, I-Pak.

A = No low ambient damper, t-stat.

B = Low ambient, I-Pak.

C = Low ambient, t-stat.

Digit 10, 11 - Design Sequence

** = Factory Assigned

Digit 12 - Unit Finish

1 = Paint, Slate Gray

2 = Protective coating

3 = Protective coating with
finish coat

Digit 13 - Coil Options

A = Non-coated aluminum

C = Protective coating aluminum

Digit 14 - Unit Isolators

0 = None

A = Spring isolators

B = Isopads

Digit 15 - Panels

0 = None

1 = Louvered panels

Digit 16 - Agency Listing

0 = None

U = With UL listing

General Data

Signature Series Self-Contained Unit Components

Commercial self contained units are complete HVAC systems used in floor-by-floor applications. Units are easy to install because they feature a single point power connection, factory installed and tested controls, single water point connection, factory installed options, and an internally trapped drain connection.

See [Figure 1, p. 9](#) and [Figure 2, p. 10](#) for typical unit components.

The hermetically sealed scroll compressor motors utilize internal motor protection and time delays to prevent excessive cycling.

Water-cooled units have 2-6 refrigerant circuits and ship with a full refrigerant and oil charge. Each circuit includes filter drier, pressure relief valve, sight glass/moisture indicator, thermal expansion valve with sensing bulb and external equalizing line, discharge line schrader valve, suction line schrader valve and high and low pressure cutout switches. The water-cooled condensers are shell

and tube type with an internal subcooler. Condensers are available as mechanically or chemically cleanable.

Air-cooled units have two circuits and ship with oil and a dry nitrogen holding charge. Therefore, air-cooled units require field piping refrigerant connections to an air-cooled condensing unit and charging. Each circuit includes filter drier (field installed), sight glass/moisture indicator, thermal expansion valve with sensing bulb and external equalizing line, discharge line schrader valve, suction line schrader valve, high and low pressure cutout switches, discharge line check valve and liquid line solenoid valve.

All units include liquid line service valves for each circuit as standard (suction and discharge service valves are optional).

Evaporator fans are double width, double inlet and forward curved with fixed pitch belt drive assembly. Variable frequency drives are optional. EISA efficiency open drip proof (ODP) and totally enclosed fan cooled (TEFC) motor options are available.

Figure 1. IntelliPak™ commercial self-contained signature series unit components

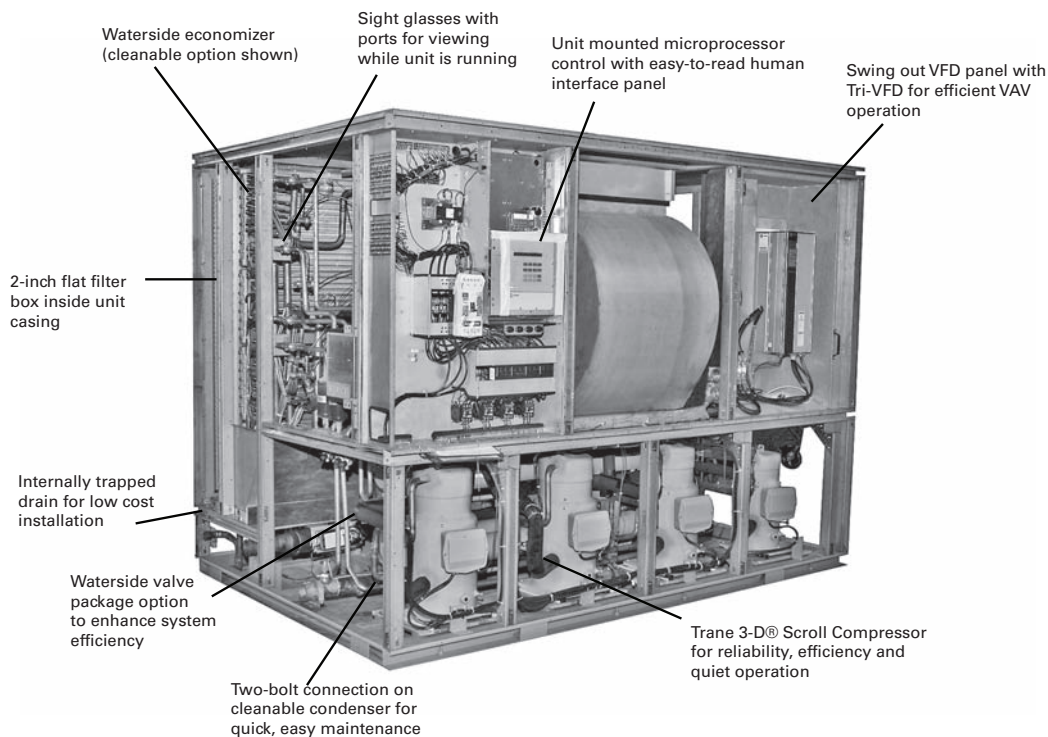

Standard Controls

Standard controls supplied with the unit include the human interface (HI) panel with unit control module (UCM). All basic setup parameters are preset from the factory.

Human Interface Panel

The HI is unit mounted and accessible without opening the unit's front panel. It allows easy setpoint adjustment using the HI keypad. In addition, the HI displays all unit operating parameters and conditions in a clear language display,



General Data

which can be configured for either English, French, or Spanish.

The optional remote human interface (RHI) will control up to four self-contained units, each containing an interprocessor communications bridge (IPCB). It has all the same features as the unit-mounted HI except for the service mode.

For more information on setpoint defaults and ranges and unit programming, see the *IntelliPak™ Self-Contained Programming Guide, PKG-SVP01*-EN*. A copy ships with each unit.

Figure 2. Right side view of unit

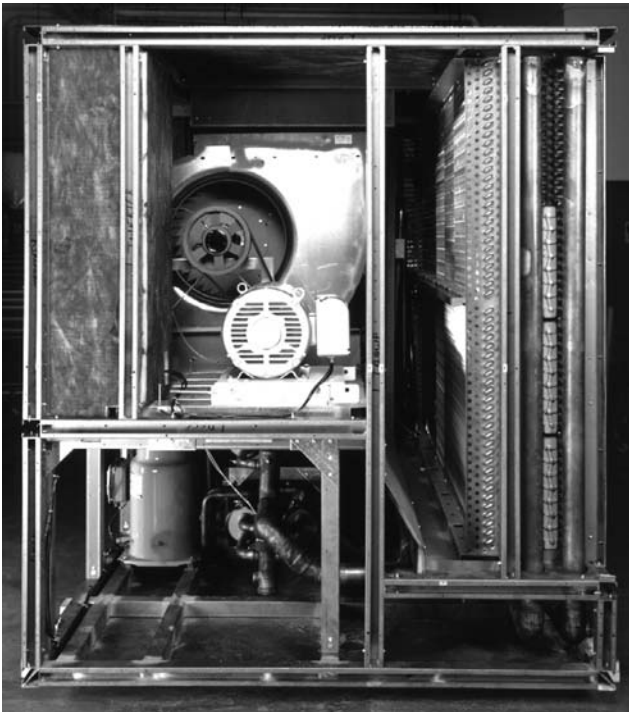

Unit Control Module

The UCM provides “smart” unit control with safety features and control relays for pumps, dampers, etc. The Signature Series IntelliPak self-contained unit is controlled by a microelectronic control system that consists of a network of modules. These modules are referred to as unit control modules (UCM). In this manual, the acronym UCM refers to the entire control system network.

These modules perform specific unit functions using proportional/integral control algorithms. They are mounted in the unit control panel and are factory wired to their respective internal components. Each module receives and interprets information from other unit modules, sensors, remote panels, and customer binary contacts to satisfy the applicable request; i.e., economizing, mechanical cooling, heating, ventilation.

See the Owner’s section of this manual for a detailed description of each module’s function.

Optional Controls

Optional controls include a disconnect switch, dirty filter switch, water flow switch (water-cooled only), supply air temperature reset, or external setpoint inputs. Daytime heating is available on units with electric, steam, or hot water heat control options. Morning warm-up operation is available on all units.

The static pressure probe, zone night heat/morning warm-up, supply air temperature reset sensor options ship separate inside the unit control panel for field installation. For more detailed information on the unit control options, see the Owner’s section of this manual.

Unit Nameplate

The unit nameplate identifies the unit model number, appropriate service literature, and wiring diagram numbers. It is mounted on the left end of the unit control panel.

General Data

Table 1. SCWF/SIWF Water-cooled self-contained, 20 to 42 tons

Unit Size	20	22	25	29	32	35	38	42
Compressor Data								
Quantity	2	2	2	1/1	1/1	3	3	2/1
Nominal Ton/comp	10	10	10	15/10	15/10	10	10	10/15
Circuits	2	2	2	2	2	3	3	3
Evaporator Coil Data								
Rows	2	2	3 or 6	2	4 or 6	3	4 or 6	3
Sq. Ft.	21.81	21.81	21.81	29.98	29.98	31.35	31.35	38.57
FPF	144	144	144	144	144	144	144	144
Condenser Data								
Minimum gpm w/o Econ	36	36	36	46	46	54	54	64
Minimum gpm w/ Econ	41	41	41	60	60	65	65	64
Maximum gpm	80	80	80	102	102	119	119	142
Evaporator Fan Data								
Quantity	1	1	1	1	1	1	1	1
Diameter (in.)	18	18	18	18	18	20	20	25
Minimum hp	5	5	5	5	5	5	5	7.5
Minimum kW	(3.73)	(3.73)	(3.73)	(3.73)	(3.73)	(3.73)	(3.73)	(5.39)
Maximum hp	20	20	20	20	20	25	25	30
Maximum kW	(14.91)	(14.91)	(14.91)	(18.64)	(18.64)	(18.64)	(18.64)	(22.37)
Minimum Design cfm	6325	6325	6500	8700	8700	9100	9880	11200
Maximum Design cfm	8500	9350	10625	12325	13600	14875	16150	17850
High Capacity Option								
Rows	—	—	6	—	6	—	6	—
Optional Low Flow Fan*								
Diameter (in.)	—	—	—	—	—	—	18	—
Min/max Design cfm	—	—	—	—	—	—	6000/13600	—
General Data R-410A								
EER	14.0	14.0	14.0	14.0	14.3	14.0	14.2	14.2
IEER (CV)	15.3	15.3	15.0	15.6	15.2	15.2	14.9	15.6
IEER (VAV)	17.4	17.4	17.5	18.1	18.8	18.0	18.5	18.3
Refrigerant Charge, lbs. R-410A								
Circuit A	19.5	19.5	21.5	22.0	28.5	21.5	23.5	22.0
Circuit B	19.5	19.5	21.5	19.5	23.5	21.5	23.5	22.0
Circuit C	—	—	—	—	—	21.5	23.5	22.0
Capacity Steps - %	100/53/0	100/53/0	100/53/0	100/62/39/0	100/59/39/0	100/65/31/0	100/65/30/0	100/71/43/26/0

Notes:

1. Compressors are Trane 3-D™ scroll.
2. EER and IEER are rated in accordance to AHRI Standard 340/360-2010. Based on 80/67° F (26.7/19.4 °C) to evaporator coil, nominal airflow and 85-95 °F (29.4/35 °C) condenser water.
3. All units operate with R-410A. Units ship with full operating charge.
4. Maximum cfm limits are set to prevent moisture carryover on the evaporator coil.
5. Minimum cfm limits are set to ensure stable thermal expansion valve operation at low load conditions.

*Optional low flow fan (unit model number digit 23 = 1) is available ONLY when High Capacity option is selected (unit model number digit 5 = V).



General Data

Table 2. SCWF/SIWF Water-cooled self-contained, 46-110 tons

Unit Size	46	52	58	65	72	80	90	100	110
Compressor Data									
Quantity	2/1	3	3	3/1	3/1	4	5	2/4	6
Nominal Ton/Comp	10/15	15	15	15/10	15/10	15	15	10/15	15
Circuits	3	3	3	4	4	4	5	6	6
Evaporator Coil Data									
Rows	4 or 6	2	4 or 6	3	4 or 6	6	6	6	6
Sq. Ft.	38.57	49.09	49.09	49.09	49.09	49.09	56.81	56.81	56.81
FPF	144	144	144	144	144	144	144	144	144
Condenser Data									
Min gpm w/o Econ	64	84	84	102	102	112	140	168	168
Min gpm w/ Econ	64	84	84	102	102	112			
Maximum gpm	142	186	186	226	226	248	300	350	350
Evaporator Fan Data									
Quantity	1	1	1	1	1	1	1	1	1
Diameter (in.)	25	25	25	27.5	27.5	27.5	27.5	27.5	27.5
Minimum hp	7.5	7.5	7.5	10	10	10	15	15	15
Minimum kW	(5.59)	(7.46)	(7.46)	(7.46)	(7.46)	(7.46)	(11.19)	(11.19)	(11.19)
Maximum hp	30	40	40	50	50	50	60	60	60
Maximum kW	(22.37)	(37.29)	(37.29)	(37.29)	(37.29)	(37.29)	(44.74)	(44.74)	(44.74)
Min Design cfm	11960	14250	15080	16900	18700	20800	17500	17500	17500
Max Design cfm	19550	22100	24650	27625	29800	29800	35000	35000	35000
High Capacity Option									
Rows	6	—	6	—	6	—	8	8	8
Optional Low Flow Fan*									
Diameter (in.)	18	—	18	—	20	—	—	—	—
Min./Max Design cfm	7700/13600	—	8900/13600	—	10700/16150	—	—	—	—
General Data R-410A									
EER	14.3	14.0	14.3	14.0	14.0	14.0	14.1	14.1	14.0
IEER (CV)	15.2	15.7	15.3	15.4	14.9	14.6	16.3	16.3	16.3
IEER (VFD)	18.8	17.9	18.9	18.2	18.5	19.3	18.6	18.5	18.1
Refrigerant Charge — lbs. R-410A									
Circuit A	24.5	21.0	26.5	22.0	24.5	28.0	24.5	24.5	24.5
Circuit B	24.5	21.0	26.5	22.0	24.5	28.0	24.5	24.5	24.5
Circuit C	24.5	21.0	26.5	22.0	24.5	28.0	24.5	24.5	24.5
Circuit D	—	—	—	21.0	22.0	28.0	24.5	24.5	24.5
Circuit E	—	—	—	—	—	—	24.5	24.5	24.5
Circuit F	—	—	—	—	—	—	—	24.5	24.5
Capacity Steps - %	100/70/41/30/0	100/65/32/0	100/65/30/0	100/71/44/24/0	100/71/43/23/0	100/73/46/20/0	100/80/40/20/0	100/75/38/19/0	100/66/33/17/0

Notes:

1. Compressors are Trane 3-D™ scroll.
2. EER and IEER are rated in accordance to ARI Standard 340/360-2007. Based on 80/67° F (26.7/19.4 °C) to evaporator coil, nominal airflow and 85-95 °F (29.4/35 °C) condenser water.
3. All units operate with R-410A. Units ships with full operating charge.
4. Maximum cfm limits are set to prevent moisture carryover on the evaporator coil.
5. Minimum cfm limits are set to ensure stable thermal expansion valve operation at low load conditions.

*Optional low flow fan (unit model number digit 23 = 1) is available ONLY when High Capacity option is selected (unit model number digit 5 = V).

Table 3. SCRF/SIRF Air-cooled self-contained

Unit Size	20	25	29	30	35	40	50	60
Compressor Data								
Quantity	2	1/1	1/1	3	3	2/1	3	4
Nominal Ton/Comp	10	15/10	15/10	10	10	10/15	15	15
Circuits	2	2	2	2	2	2	2	2
Evaporator Coil Data								
Rows	3	2	4	3	4	4	4	6
Sq. Ft.	21.81	29.98	29.98	31.35	31.35	38.57	49.09	49.09
FPF	144	144	144	120	144	144	144	144
Evaporator Fan Data								
Quantity	1	1	1	1	1	1	1	1
Diameter (in.)	18	18	18.25	20	20	25	25	27.5
Minimum hp	5	5	5	5	5	7.5	10	10
Minimum kW	(3.73)	(3.73)	(3.73)	(3.73)	(3.73)	(5.59)	(7.46)	(7.46)
Maximum hp	20	20	20	25	25	30	40	50
Maximum kW	(14.91)	(18.64)	(18.64)	(18.64)	(18.64)	(22.37)	(37.29)	(37.29)
Minimum Design cfm	6500	8700	8700	9100	9880	11960	15080	20800
Maximum Design cfm	10625	12325	13600	14875	16150	19550	24650	29800
General Data								
EER	10.0	10.0	10.5	10.4	10.6	10.7	10.5	10.3
IEER (CV)	10.8	11.6	12.2	12.5	12.0	12.7	12.1	11.2
IEER (VAV)	11.9	12.8	13.7	13.5	13.9	14.4	13.7	14.1
Refrigerant Charge	See Note 6							
Capacity Steps - %	100/53/0	100/62/39/0	100/59/39/0	100/65/31/0	100/65/30/0	100/70/41/30/0	100/65/30/0	100/73/46/20/0
CCRC/CIRC Unit Match	20	29	29	35	35	40	50	60

Notes:

1. Compressors are Trane 3-D™ scroll.
2. EER and IEER are rated in accordance to ARI Standard 340/360-2007. Based on 80/67° F (26.7/19.4 °C) to evaporator coil, nominal airflow and 85-95 °F (29.4/35 °C) condenser water.
3. All units operate with R-410A.
4. Maximum cfm limits are set to prevent moisture carryover on the evaporator coil.
5. Minimum cfm limits are set to ensure stable thermal expansion valve operation at low load conditions.
6. Units ship with Dry Nitrogen Charge. Field refrigerant system charge required. Refer to [Table 5, p. 14](#) for amounts required.



General Data

Table 4. CCRC/CIRC Remote air-cooled condenser

Unit Size	20	29	35	40	50	60
Condenser Fan Data						
Number/Type/Drive	4/Prop/Direct	4/Prop/Direct	6/Prop/Direct	6/Prop/Direct	8/Prop/Direct	8/Prop/Direct
Diameter (in.)	26	26	26	26	26	26
Diameter (mm)	(660.4)	(660.4)	(660.4)	(660.4)	(660.4)	(660.4)
HP ea.	1	1	1	1	1	1
Nominal cfm	18,800	21,200	35,600	39,800	46,200	56,400
Nominal (liters / sec)	(8873)	(10005)	(16801)	(18784)	(21804)	(26618)
Condenser Coil Data						
Circuit 1 Size (in.)	1/46x71	1/64x71	2/46x71	2/46x71	2/64x71	2/64x71
Circuit 1 Size (mm)	(1/1168x1803)	(1/1626x1803)	(2/1168x1803)	(2/1168x1803)	(2/1626x1803)	(2/1626x1803)
Circuit 2 No./Size (in.)	1/46x71	1/46x71	1/46x71	1/64x71	1/64x71	2/64x71
Circuit 2 No./Size (mm)	(1/1168x1803)	(1/1168x1803)	(1/1168x1803)	(1/1626x1803)	(1/1626x1803)	(2/1626x1803)
Face Area (sq. ft.)	45.4	54.2	68	76.9	94.7	126.2
Face Area (sq.m)	(4.2)	(5)	(6.3)	(7.1)	(8.8)	(11.7)
Rows/fpf	4/144	4/144	4/144	4/144	4/144	4/144
Ambient Temperature Operating Range						
Standard Ambient (F)	50-115	50-115	50-115	50-115	50-115	50-115
Standard Ambient (C)	(10 - 46.1)	(10 - 46.1)	(10 - 46.1)	(10 - 46.1)	(10 - 46.1)	(10 - 46.1)
Low Ambient Option (F)	0-115	0-115	0-115	0-115	0-115	0-115
Low Ambient Option (C)	(-17.8 - 46.1)	(-17.8 - 46.1)	(-17.8 - 46.1)	(-17.8 - 46.1)	(-17.8 - 46.1)	(-17.8 - 46.1)

Note: Units ship with Dry Nitrogen Charge. Field refrigerant system charge required. Refer to Table 5, p. 14 for amounts required.

Table 5. SCRF/SIRF Air-cooled self-contained and CCRC/CIRC remote air-cooled condenser, refrigerant data

SCRF/SIRF & CCRC/CIRC Unit Size	20/20	25/29	29/29	30/35	35/35	40/40	50/50	60/60
No. of Refrigerant Circuits	2	2	2	2	2	2	2	2
Operating Charge - lbs. R-410A	35.5/35.5	44.5/33.5	51/37.5	71/35.5	75/37.5	86.5/39.5	98/50	101.5/101.5
Operating Charge - kg R-410A	16.1/16.1	20.2/15.2	23.1/17	32.2/16.1	34/17	39.2/17.9	44.5/22.7	46/46
Cond. Storage Cap. - lbs. R-410A	37/37	51/37	51/37	74/37	74/37	74/51	102/51	102/102
Cond. Storage Cap. - kg R-410A	16.8/16.8	23.1/16.8	23.1/16.8	33.6/16.8	33.6/16.8	33.6/23.1	46.3/23.1	46.3/46.3

Notes:

1. Refrigerant charges are listed as circuit 1/circuit 2 and provide only an estimate. Final charge requires sound field charging practice.
2. Operating charge is for entire system, including air-cooled self-contained, remote air-cooled condenser, and 25 feet of interconnecting refrigerant piping.
3. See Table 25, p. 36 for additional charge required for alternate interconnecting piping lengths.
4. At conditions of 95° F (35° C), condenser storage capacity is 95% full.
5. To determine the correct amount of refrigerant needed for a particular application, reference the Trane Reciprocating Refrigeration Manual.

Table 6. SCWF/SIWF water flow volumes

Unit Size	Water Volume in U.S. Gallons / Liters					
	w/o Economizer		With Mech. Cleanable Econ		With Chem. Cleanable Econ	
	Gallons	Liters	Gallons	Liters	Gallons	Liters
20	9.0	34.1	17.4	65.9	16.9	64.0
22	9.0	34.1	17.4	65.9	16.9	64.0
25	9.0	34.1	17.4	65.9	16.9	64.0
29	9.0	34.1	20.5	77.6	18.8	71.2
32	9.0	34.1	20.5	77.6	18.8	71.2
35	10.0	37.9	21.9	82.9	20.2	76.5
38	10.0	37.9	21.9	82.9	20.2	76.5
42	15.0	56.8	32.2	121.9	31.4	118.9
46	15.0	56.8	32.2	121.9	31.4	118.9
52	15.0	56.8	36.9	139.7	35.9	135.9
58	15.0	56.8	36.9	139.7	35.9	135.9
65	16.0	60.6	37.9	143.5	36.9	139.7
72	16.0	60.6	37.9	143.5	36.9	139.7
80	16.0	60.6	37.9	143.5	36.9	139.7
90	22.5	85.2	50.1	189.6	N/A	N/A
100	23.0	87.1	50.6	191.5	N/A	N/A
110	24.0	90.8	51.6	195.3	N/A	N/A

Table 7. SCWF/SIWF Refrigerant circuits, number of compressors by circuit

Unit Size	Circuit					
	1	2	3	4	5	6
20/22/25 Ton	1- 10T	1- 10T				
29/32 Ton	1- 15T	1- 10T				
35/38 Ton	1- 10T	1- 10T	1- 10T			
42/46 Ton	1- 15T	1- 10T	1- 10T			
52/58 Ton	1- 15T	1- 15T	1- 15T			
60/72 Ton	1- 15T	1- 15T	1- 15T	1- 10T		
80 Ton	1- 15T	1- 15T	1- 15T	1- 15T		
90 Ton	1- 15T	1- 15T	1- 15T	1- 15T	1- 15T	
100 Ton	1-15T	1-15T	1-15T	1-15T	1-10T	1-10T
110 Ton	1- 15T	1- 15T	1- 15T	1- 15T	1- 15T	1- 15T

Note: This table depicts compressor location in unit, plan view from left corner.

Table 8. SCRF/SIRF Refrigerant circuits, number of compressors by circuit

Unit Size	Circuit 1	Circuit 2
20 Ton	1-10T	1- 10T
25/29 Ton	1-15T	1-10T
30/35 Ton	2-10T	1-10T
40 Ton	1-10T, 1-15T	1-10T
50 Ton	2-15T	1-15T
60 Ton	2-15T	2-15T

Note: This table depicts compressor location in unit, plan view from left corner.



General Data

Table 9. Filter data, water-cooled units models SCWF & SIWF

Unit Size	20- 38T	40-85T	90-110T
Number - Size (In.)	8 - 20x18 4 - 20 x 20	12 - 25 x 20 6 - 20 x 20	15 - 24 x 24 3 - 24 x 12
Units With Hot Water Or Steam			
Number - Size (In.)	4 - 16x20 4 - 20 x 20 4 - 18 x 20	4 - 25 x 20 2 - 20 x 20 8 - 25 x 16 4 - 20 x 16	n/a

Table 10. Filter data, air-cooled units models SCRF & SIRF

Unit size	20- 35 tons	40-60 tons
Number - Size (in.)	8 - 20x18 4 - 20 x 20	12 - 25 x 20 6 - 20 x 20
Units With Hot Water Or Steam		
Number - Size (in.)	4 - 16x20 4 - 20 x 20 4 - 18 x 20	4 - 25 x 20 2 - 20 x 20 8 - 25 x 16 4 - 20 x 16

Table 11. Self-Contained Heating Coil

Unit Size	SCWF 20 - 38	SCWF 42 - 80	SCRF 20 - 35	SCRF 40 - 60
Steam Coil				
Coil Type	NS	NS	NS	NS
Rows	1	1	1	1
No./Size (in.)	(2) 24 x 58	(2) 30 x 81	(2) 24 x 58	(2) 30 x 81
No./Size (mm)	(2) 609.6 x 1473.2	(2) 762 x 2057.4	(2) 609.6 x1 473.2	(2) 762 x 2057.4
FPF	42	42	42	42
Hot Water Coil				
Coil Type	5W	5W	5W	5W
Rows	1 or 2			
No./Size (in)	(2) 24 x 58	(2) 30 x 81	(2) 24 x 58	(2) 30 x 81
No./Size (mm)	(2) 609.6 x 1473.2	(2) 762 x 2057.4	(2) 609.6 x 1473.2	(2) 762 x 2057.4
FPF	80 or 108	80 or 108	80 or 108	80 or 108

Notes:

- Hot water and steam heating coils have Prima-Flo® fins without turbulators.
- For coil capacities, use TOPSS™ (Trane Official Product Selection Program).
- Full capacity coils consist of two coils stacked and piped in parallel.

Table 12. Waterside economizer coil physical data - SCXF

Unit Size	Type	Rows	FPF	Height (in)	Length (in)
20, 22 & 25	Chemically Cleanable	2	108	40	78.5
20, 22 & 25	Mechanical Cleanable	2	108	40	78.5
20, 22 & 25	Chemically Cleanable	4	108	40	78.5
20, 22 & 25	Mechanical Cleanable	4	108	40	78.5
29 & 32	Chemically Cleanable	2	108	55	78.5
29 & 32	Mechanical Cleanable	2	108	55	78.5
29 & 32	Mechanical Cleanable	4	108	55	78.5
29 & 32	Chemically Cleanable	4	108	55	78.5
35 & 38	Chemically Cleanable	2	108	57.5	78.5
35 & 38	Mechanical Cleanable	2	108	57.5	78.5
35 & 38	Chemically Cleanable	4	108	57.5	78.5
35 & 38	Mechanical Cleanable	4	108	57.5	78.5
42 & 46	Chemically Cleanable	2	144	55	101
42 & 46	Mechanical Cleanable	2	144	70	101
42 & 46	Chemically Cleanable	4	144	55	101
42 & 46	Mechanical Cleanable	4	144	70	101
52, 58, 65, 72, 80, 85	Chemically Cleanable	2	144	70	101
52, 58, 65, 72, 80, 85	Mechanical Cleanable	2	144	70	101
52, 58, 65, 72, 80, 85	Chemically Cleanable	4	144	70	101
52, 58, 65, 72, 80, 85	Mechanical Cleanable	4	144	70	101
90, 100 & 110	Mechanical Cleanable	4	144	70	119.3

Pre-Installation

Receiving

Receiving Checklist

Complete following checklist immediately after receiving shipment to detect any shipping damage.

- Inspect individual cartons before accepting. Check for rattles, bent carton corners, or other visible indications of shipping damage.
- If a unit appears damaged, inspect it immediately before accepting the shipment. Make specific notations concerning the damage on the freight bill. Do not refuse delivery.
- Inspect the unit for concealed damage before it is stored and as soon as possible after delivery. Report concealed damage to the freight line within the allotted time after delivery. Check with the carrier for their allotted time to submit a claim.
- Do not move damaged material from the receiving location. It is the receiver's responsibility to provide reasonable evidence that concealed damage did not occur after delivery.
- Do not continue unpacking the shipment if it appears damaged. Retain all internal packing, cartons, and crate. Take photos of damaged material if possible.
- Notify the carrier's terminal of the damage immediately by phone and mail. Request an immediate joint inspection of the damage by the carrier and consignee.

Notify your Trane representative of the damage and arrange for repair. Have the carrier inspect the damage before making any repairs to the unit.

Ship-Separate Accessories

Field-installed sensors ship separately inside unit's main control panel. Extra filters, sheaves, and belts ship in unit's fan motor section. Condenser plugs, spring isolators, and isopads ship in unit's bottom left side.

Contractor Installation Responsibilities

Complete the following checklist before beginning final unit installation.

- Verify the unit size and tagging with the unit nameplate.
- Make certain the floor or foundation is level, solid, and sufficient to support the unit and accessory weights. Level or repair the floor before positioning the unit if necessary.
- Allow minimum recommended clearances for routine maintenance and service. Allow space at end of the unit for shaft removal and servicing. Refer to unit submittals for dimensions. See also "[Service Clearances](#)," p. 27.
- Allow three fan diameters above the unit for the discharge ductwork. Return air enters the rear of the unit and conditioned supply air discharges through the top.
- Electrical connection knockouts are on the top, left side of the unit.
- Allow adequate space for piping access and panel removal. Condenser water piping, refrigerant piping, and condensate drain connections are on the lower left end panel.

Note: *Unit height and connection locations will change if using vibration isolators. The unit height may increase up to 5 7/8" with spring type isolators.*

- Electrical supply power must meet specific balance and voltage requirements as described in section "[Installation - Electrical](#)," p. 37.
- **Water-cooled units only:** The installer is responsible for providing a condenser main, standby water pump, cooling tower, pressure gauges, strainers, and all components for waterside piping. See "[Water Piping](#)," p. 32 for general waterside recommendations.
- **Air-cooled units only:** The installer is responsible for providing and installing the remote air-cooled condenser and refrigerant piping, including filter driers.

Unpackaging

Commercial self-contained units ship assembled with protective coverings over the coil and discharge openings. [Figure 3, p. 18](#) illustrates a typical shipping package.

Figure 3. Typical unit shipping package

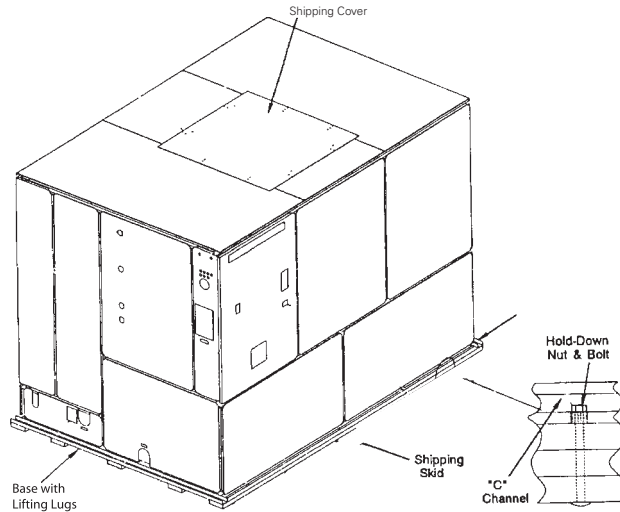

Unit Protective Covers

Remove shipping protection coverings from human interface panel (HI) at control panel, filter box (or air inlet opening), discharge air opening, and optional variable frequency drive (VFD).

Supply Fan Isolators

Remove the shipping channels and mounting bolts from beneath the fan. See [Figure 4, p. 18](#). Open both fan compartment access doors to access the channels. There

are four mounting points for 20-38 ton units and six mounting points for 40-80 ton units.

Note: For 20-38 ton units, do not remove the fan assembly shipping blocks and tie down bolts if the fan speed is 750 rpm or less.

While keeping the fan mounting frame level, turn the fan isolator height adjusting bolts until the fan housing P-gasket compresses 1/4" against the roof transition piece. See [Figure 4, p. 18](#).

Figure 4. Fan assembly shipping spacer locations

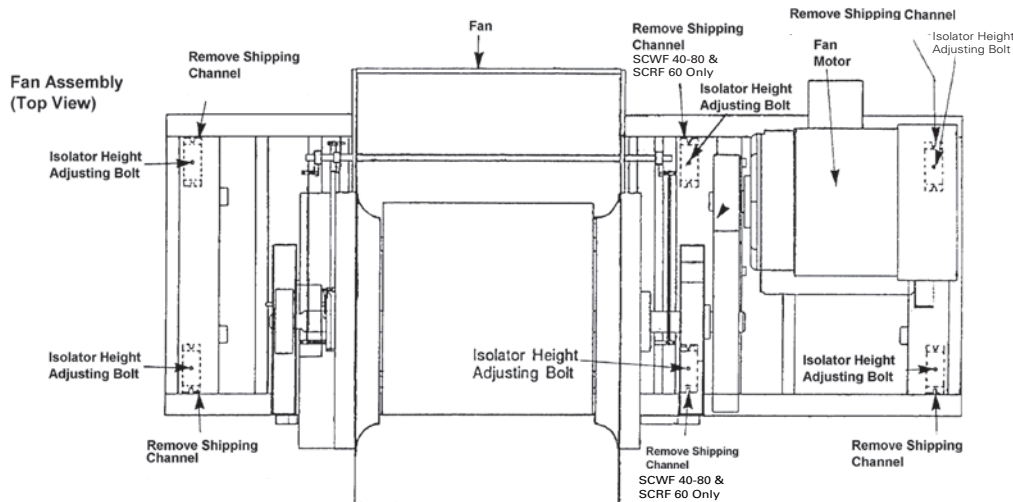



Dimensions & Weights

Table 13. Unit Weights - SCWF/SCRF/SIWF/SIRF - lb (kg)

	Unit Size	Base Weight	Airside Economizer	2-Row Waterside Economizer	4-Row Waterside Economizer	Heating Coil Box	6-Row Evap. Coil	6-inch filter rack
SCWF/SIWF	20	3102 (1407)	430 (195)	140 (64)	340 (154)	460 (209)	-	212 (96)
	22	3102 (1407)	430 (195)	140 (64)	340 (154)	460 (209)	-	212 (96)
	25	3170 (1438)	430 (195)	140 (64)	340 (154)	460 (209)	144 (65)	212 (96)
	29	3326 (1508)	500 (227)	190 (86)	390 (177)	460 (209)	-	212 (96)
	32	3514 (1594)	500 (227)	190 (86)	390 (177)	460 (209)	132 (60)	212 (96)
	35	3721 (1688)	500 (227)	280 (127)	505 (229)	460 (209)	-	212 (96)
	38	3819 (1732)	500 (227)	280 (127)	505 (229)	460 (209)	138 (63)	212 (96)
	42	4615 (2093)	640 (290)	255 (116)	505 (229)	600 (272)	-	257 (117)
	46	4705 (2134)	640 (290)	255 (116)	505 (229)	600 (272)	170 (77)	257 (117)
	52	4892 (2219)	700 (318)	335 (152)	665 (302)	600 (272)	-	257 (117)
	58	5142 (2332)	700 (318)	335 (152)	665 (302)	600 (272)	216 (98)	257 (117)
	65	5371 (2436)	800 (363)	335 (152)	665 (302)	600 (272)	-	257 (117)
	72	5491 (2490)	800 (363)	335 (152)	665 (302)	600 (272)	216 (98)	257 (117)
	80	5814 (2637)	800 (363)	335 (152)	665 (302)	600 (272)	-	257 (117)
	90	6330 (2871)	-	-	1015 (460)	-	255 (116)	-
	100	6840 (3103)	-	-	1015 (460)	-	255 (116)	-
	110	6852 (3108)	-	-	1015 (460)	-	255 (116)	-
SCRF/SIRF	20	2887 (1310)	430 (195)	-	-	460 (209)	-	-
	25	3041 (1379)	500 (227)	-	-	460 (209)	-	-
	29	3231 (1465)	500 (227)	-	-	460 (209)	-	-
	30	3321 (1506)	500 (227)	-	-	460 (209)	-	-
	35	3421 (1552)	500 (227)	-	-	460 (209)	-	-
	40	4294 (1948)	640 (290)	-	-	600 (272)	-	-
	50	4731 (2146)	700 (318)	-	-	600 (272)	-	-
	60	5288 (2399)	800 (363)	-	-	600 (272)	-	-

Notes:

1. All unit weights include refrigerant, water, inlet guide vanes and controllers, electric heat and valves.
2. Add 150 lbs. to total weight to obtain approximate shipping weight.
3. Flexible horizontal discharge plenum option weights: 45-inch plenum = 705 lbs., Standard height plenum = 430 lbs., Low height plenum = 325 lbs.

Table 14. Unit weights - CCRC/CIRC - lb (kg)

Unit Size	Shipping Weight	Operating Weight
CCRC/CIRC 20	2030 (920)	1906 (865)
CCRC/CIRC 29	2084 (945)	1960 (890)
CCRC/CIRC 32	2138 (970)	2014 (915)
CCRC/CIRC 35	3018 (1370)	2833 (1285)
CCRC/CIRC 40	3072 (1395)	2887 (1310)
CCRC/CIRC 50	3995 (1810)	3695 (1675)
CCRC/CIRC 60	4275 (1940)	3975 (1805)

Table 15. VFD weights - lb (kg)

Bypass	HP	200V	460V	575V
	7.5	26	14	14
	10	26	14	26
Without	15	52	26	26
	20	52	26	26
	25	52	26	26
	25	52	26	26

Table 15. VFD weights - lb (kg) (continued)

Bypass	HP	200V	460V	575V
Without	30	77	52	52
	40	77	52	52
	50	N/A	52	52
	60	N/A	77	N/A
With	7.5	65	20	20
	10	65	65	65
	15	70	65	65
	20	70	65	65
	25	100	65	65
	30	100	70	70
	40	140	70	70
	50	N/A	100	100
	60	N/A	100	N/A

Notes:

1. Add 100 lbs for unit swing out door on units with VFD only.
2. Add 150 lbs for units with VFD with bypass.



Dimensions & Weights

Figure 5. 20-38 ton self-contained

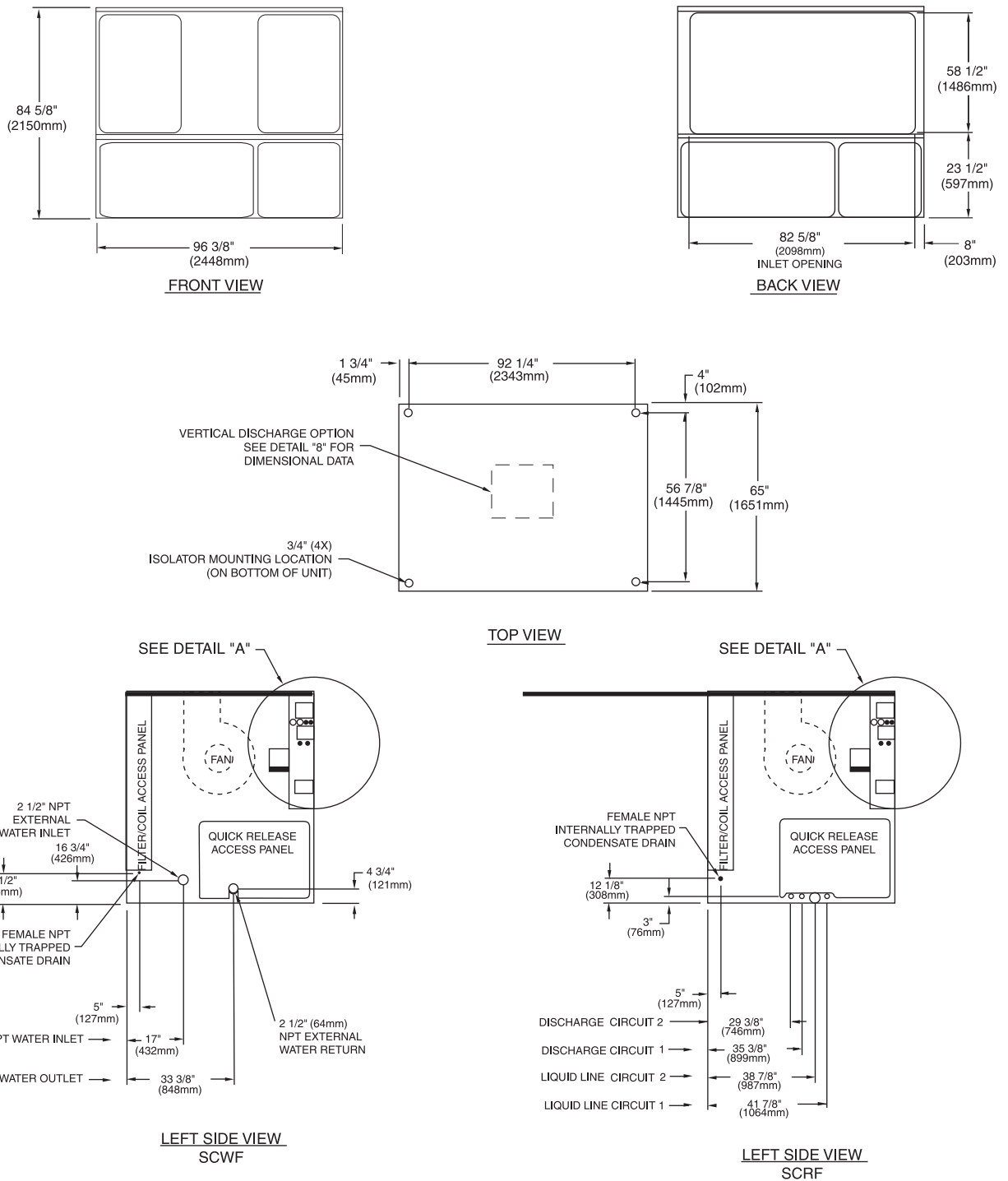

- Notes:**
1. All unit weights include refrigerant, water, controllers, electric heat and valves.
 2. Add 150 lbs. to total weight to obtain approximate shipping weight.

Figure 6. 42-80 ton self-contained

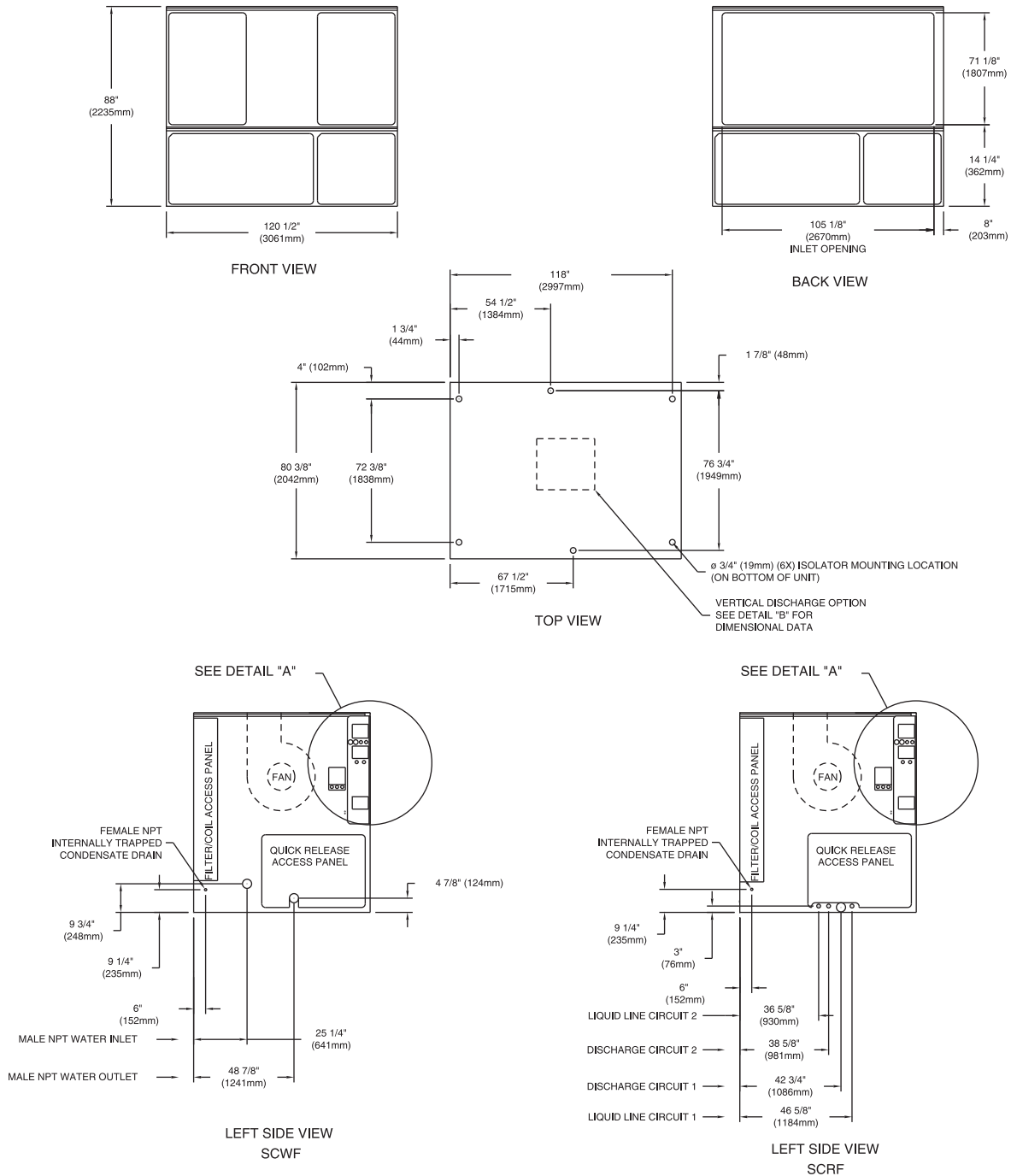

Notes:

1. All unit weights include refrigerant, water, controllers, electric heat and valves.
2. Add 150 lbs. to total weight to obtain approximate shipping weight.

Dimensions & Weights

Figure 7. 90-110 ton self-contained: front view

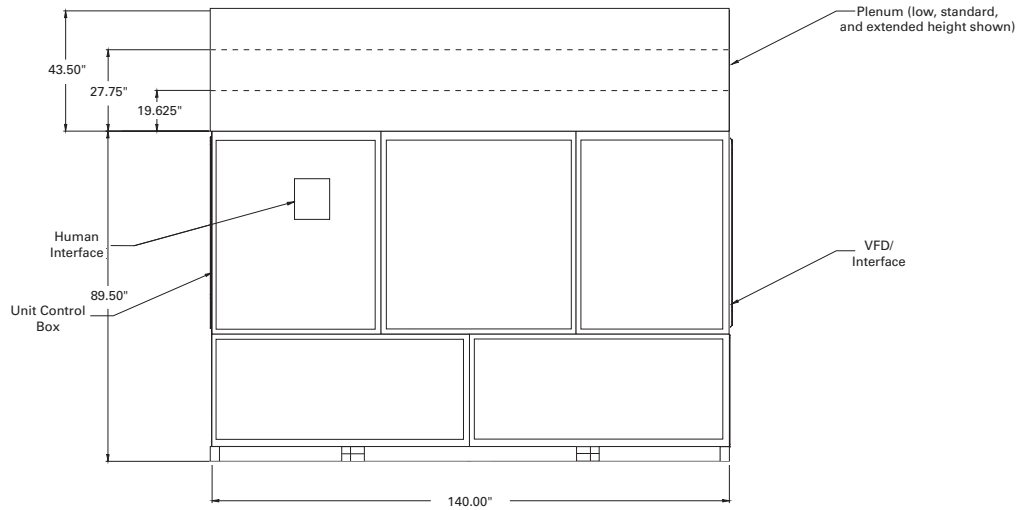

Figure 8. 90-110 ton self-contained: top view (isolator mounting locations shown)

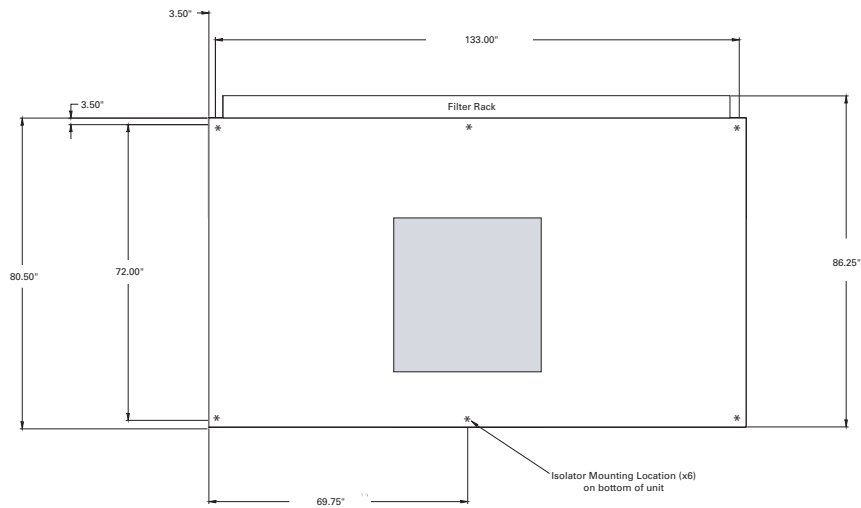

Figure 9. Detail A: electrical connections 20-110 tons

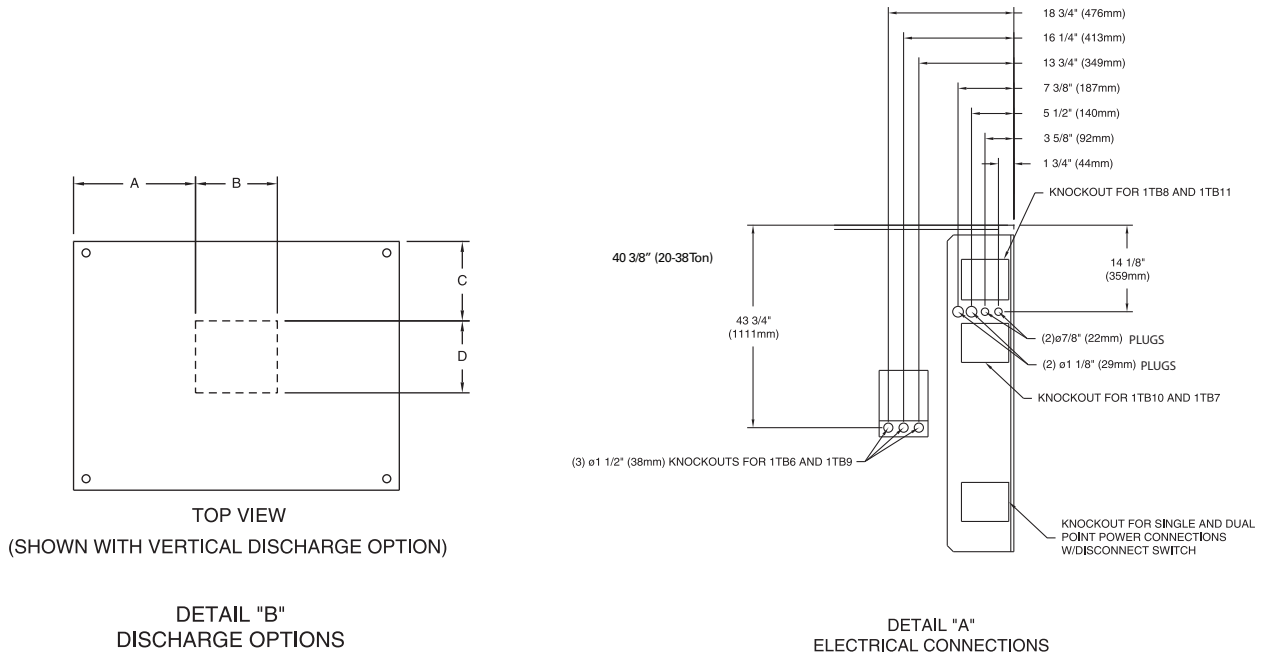
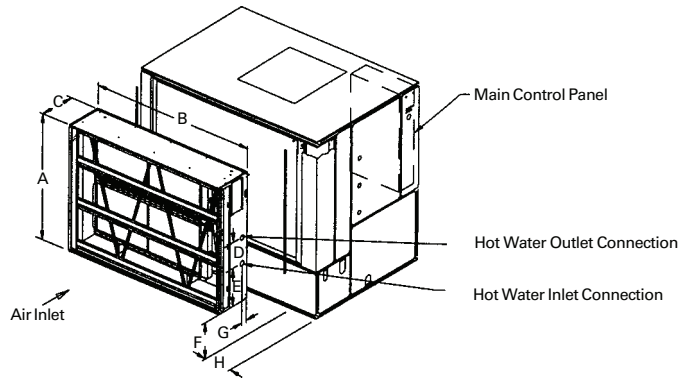

Table 16. Discharge dimensions, in.

Unit Model	Fan Size	A	B	C	D
Standard Fan					
SCWF 20-25 SCRf 20	18"	31.85	23.5	23.11	20.4
SCWF 29-32 SCRf 25-29	18"	31.85	23.5	23.11	20.4
SCWF 35-38 SCRf 30-35	20"	30.5	26.2	21.25	25.75
SCWF 42-58 SCRf 40-50	25"	43.75	33.0	31.5	31.5
SCWF 65-80 SCRf 60	27.5"	43.5	33.5	28.63	34.5
SCWF 90-110	27.5"	50.70	33.5	28.8	34.5
Low Flow Fan Option					
SCWF 38	18"	44.8	23.25	36.78	19.0
SCWF 46	18"	44.8	23.25	36.78	19.0
SCWF 58	18"	44.8	23.25	36.78	20.4
SCWF 72	20"	43.4	26.2	34.77	24.6

Dimensions & Weights

Figure 10. Hot water coil



- Notes:
1. All coils are factory mounted, piped, and wired.
 2. All piping connections are 1-1/2" (38.1mm) female NPT fittings.

Table 17. Hot water coil piping locations & weight, in-lbs.

Unit Size	A	B	C	D	E	F	G	H	weight ^(a)
20 - 38	60 3/8	82 7/8	18	20 5/8	8 1/8	22 3/8	3 5/8	8 1/4	460
42 - 80	72 7/8	105 1/4	18	24 1/2	10 3/4	13 1/4	3 5/8	8 1/4	600

(a) Weight includes complete heating coil box.

Figure 11. Steam coil

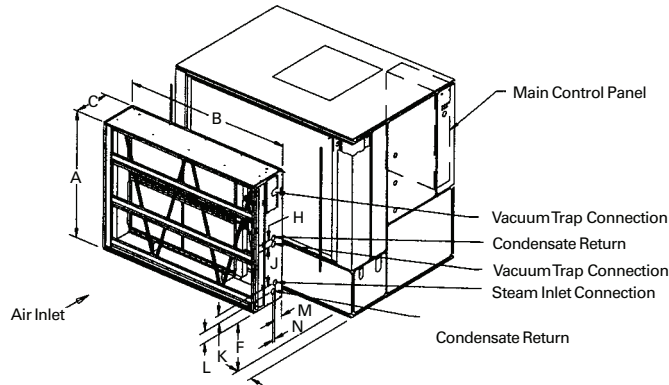

- Notes:
1. All coils are factory mounted, piped, and wired.
 2. All piping connections are 1-1/2" (38.1mm) female NPT fittings.

Table 18. Piping locations for steam coils, in-lbs.

Unit Size	A	B	C	D	E	F	G	H	J	K	L	M	N	Weight
20 - 38	60 3/8	82 7/8	18	-	-	22 3/8	-	3	18 1/2	3 7/8	5	4 3/8	1 1/4	460
42 - 80	72 7/8	105 1/4	18	-	-	13 1/4	-	3	22 1/8	6 3/8	5 3/8	4 3/8	1 1/4	600

Note: The weight includes the complete heating coil box.

Figure 12. Flexible horizontal discharge plenum

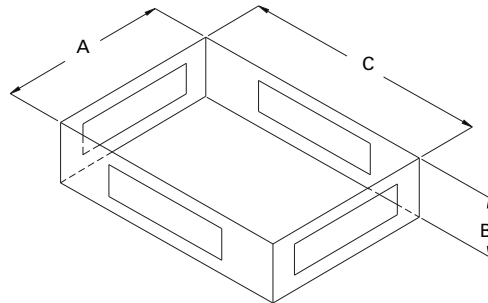

Table 19. Plenum dimensions, in-lbs.

Unit Size		A	B	C	Weight
20-38	low	64 7/8	24 5/8	95 7/8	325
	std.	64 7/8	32 3/8	95 7/8	430
	ext.	64 7/8	45	95 7/8	705
42-80	low	80 3/8	21 1/8	119 7/8	390
	std.	80 3/8	28 5/8	119 7/8	540
	ext.	80 3/8	45	119 7/8	705
90-110	low	80 1/2	19 5/8	140	430
	std.	80 1/2	27 3/4	140	595
	ext.	80 1/2	43 1/2	140	795

Figure 13. Six-inch filter rack

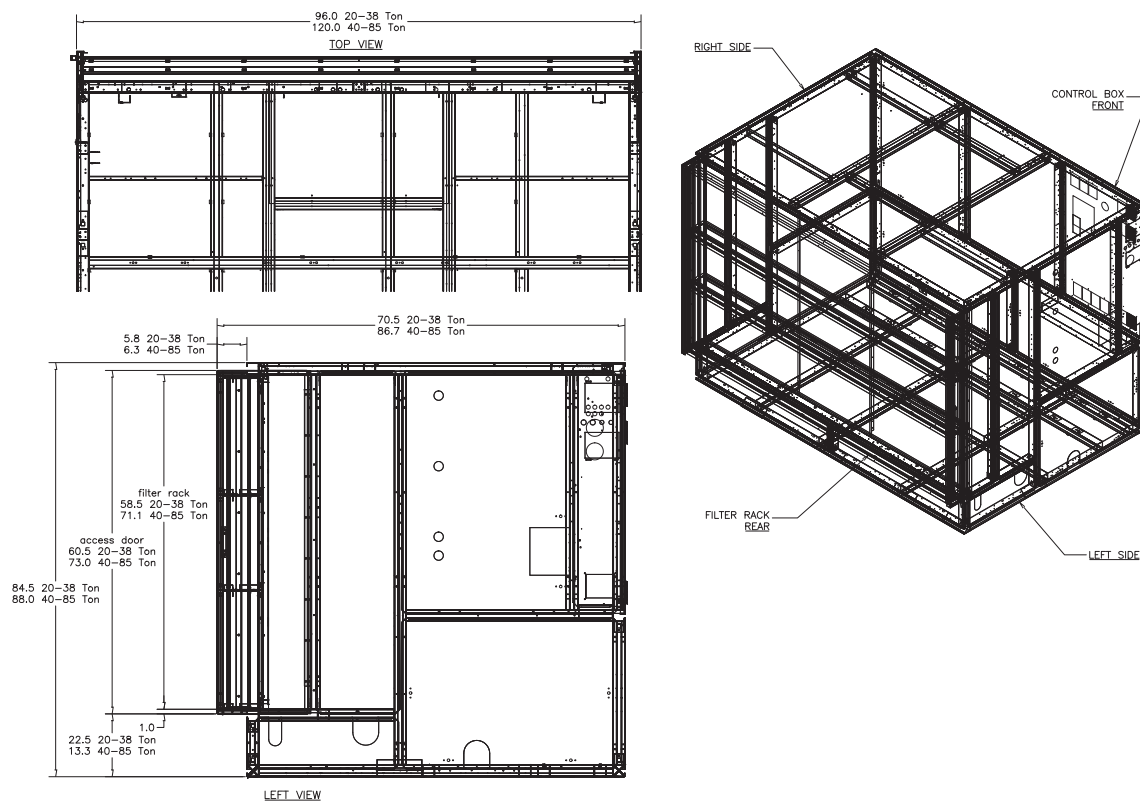

Table 20. Six-inch filter rack weight, lbs.

Unit Size	Weight
20-38	212
42-80	257



Dimensions & Weights

Airside Economizer

Figure 14.

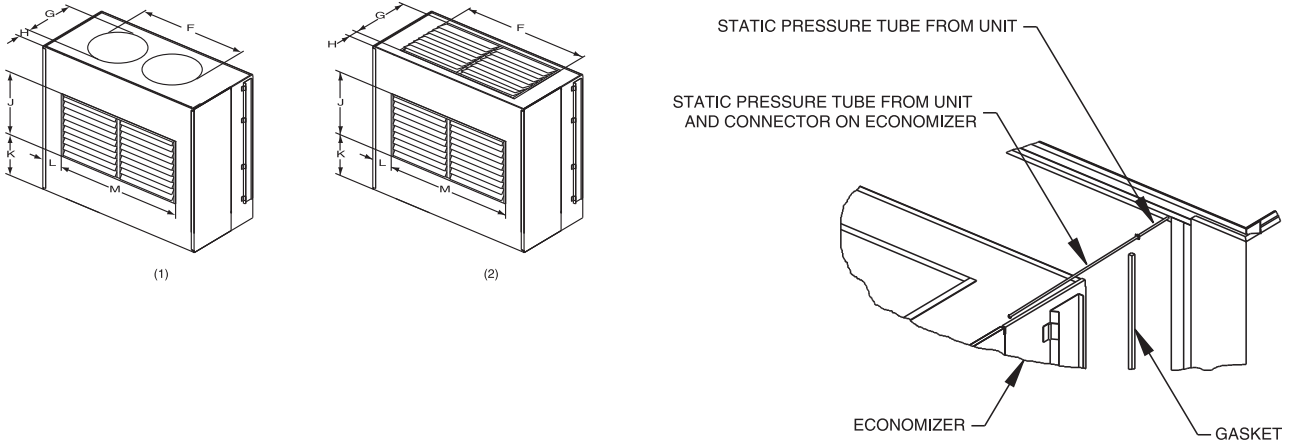

Figure 15.

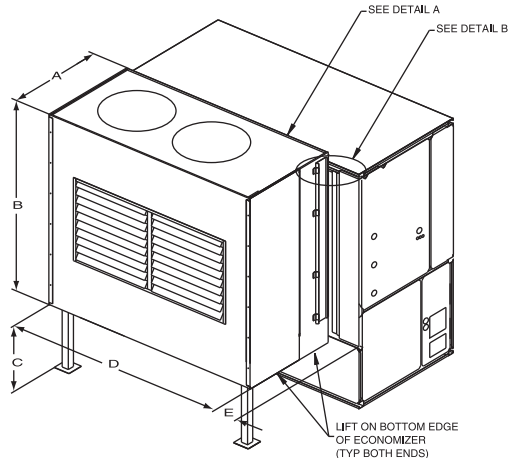

Table 21. Airside economizer dimensions - in

Size	A	B	C	D	E	F (1)	F (2)	G (1)	G (2)	H (1)	H (2)	J	K	L	M	Weight
SXWF 20	44	74	22 3/8	81 3/4	8 3/4	66 3/4	49 3/4	23 1/4	20 1/2	9 3/4	11 1/8	20 1/2	22 1/4	16	49 3/4	430
SXRF 20	44	74	22 3/8	81 3/4	8 3/4	68 5/8	49 3/4	28 1/8	20 1/2	7 1/4	11 1/8	20 1/2	22 1/4	16	49 3/4	500
SXRF 25	44	74	22 3/8	81 3/4	8 3/4	68 5/8	49 3/4	28 1/8	20 1/2	7 1/4	11 1/8	20 1/2	22 1/4	16	49 3/4	500
SXWF 22	44	74	22 3/8	81 3/4	8 3/4	68 5/8	49 3/4	28 1/8	20 1/2	7 1/4	11 1/8	20 1/2	22 1/4	16	49 3/4	500
SXRF 29	44	74	22 3/8	81 3/4	8 3/4	74 1/4	62 3/4	23 1/4	20 1/2	9 3/4	11 1/8	20 1/2	22 1/4	9 1/2	62 3/4	500
SXWF 32	44	74	22 3/8	81 3/4	8 3/4	74 1/4	62 3/4	23 1/4	20 1/2	9 3/4	11 1/8	20 1/2	22 1/4	9 1/2	62 3/4	500
SXRF 30-35	44	74	22 3/8	81 3/4	8 3/4	73 1/2	62 3/4	33	20 1/2	4 7/8	11 1/8	20 1/2	22 1/4	9 1/2	62 3/4	500
SXWF 35-38	44	74	22 3/8	81 3/4	8 3/4	73 1/2	62 3/4	33	20 1/2	4 7/8	11 1/8	20 1/2	22 1/4	9 1/2	62 3/4	500
SXWF 42	57 3/8	86 1/2	13 1/4	104 3/8	8 7/8	83 5/8	63 1/2	33	26	2 1/2	15	26	24 3/4	20 3/8	63 1/2	640
SXRF 40	57 3/8	86 1/2	13 1/4	104 3/8	8 7/8	94 1/8	63 1/2	28 1/8	26	6 7/8	15	26	24 3/4	20 3/8	63 1/2	640
SXWF 46	57 3/8	86 1/2	13 1/4	104 3/8	8 7/8	94 1/8	63 1/2	28 1/8	26	6 7/8	15	26	24 3/4	20 3/8	63 1/2	640
SXRF 50	57 3/8	86 1/2	13 1/4	104 3/8	8 7/8	96 5/8	63 1/2	52	37 1/2	1 7/8	9 1/4	37 1/2	19	20 3/8	63 1/2	700
SXRF 60	57 3/8	86 1/2	13 1/4	104 3/8	8 7/8	96 5/8	63 1/2	52	37 1/2	1 7/8	9 1/4	37 1/2	19	20 3/8	63 1/2	700
SXRF 52-58	57 3/8	86 1/2	13 1/4	104 3/8	8 7/8	96 5/8	63 1/2	52	37 1/2	1 7/8	9 1/4	37 1/2	19	20 3/8	63 1/2	700
SXWF 65-80	57 3/8	86 1/2	13 1/4	104 3/8	8 7/8	96 5/8	63 1/2	52	37 1/2	1 7/8	9 1/4	37 1/2	19	20 3/8	63 1/2	800

Service Clearances

See [Figure 16](#) for recommended service and code clearances.

Figure 16. Top view of self-contained unit showing recommended service and code clearances^(a)

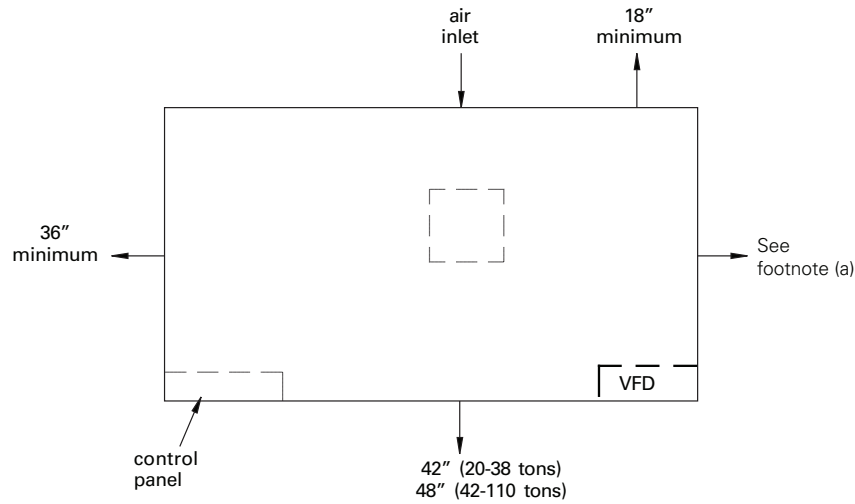

(a) See [Table 22, p. 27](#) for right side clearance values for various unit configurations.

Table 22. Service and code clearance requirements

Side	Distance	Purpose
front	42 in. (20-38 tons)	NEC code requirement
	48 in. (42-110 tons)	fan service/removal
left	36 in.	filter, refrigeration, & waterside components
right	9 in.	non VFD w/ open return
	18 in.	non VFD w/ ducted return
	9 in.	20-80 tons, w/ VFD 7.5 to 50 hp
	36 in.	90-110 ton units w/ VFD 25 to 50 hp
inlet	18 in.	provides uniform airflow

Installation - Mechanical

Unit Handling Procedure

⚠ WARNING

Improper Unit Lift!

Test lift unit approximately 24 inches to verify proper center of gravity lift point. To avoid dropping of unit, reposition lifting point if unit is not level. Failure to properly lift unit could result in unit dropping and possibly crushing operator/technician which could result in death or serious injury and possible equipment or property-only damage.

1. Use spreader bars to avoid unit damage.
2. Spreader bar must be a minimum of 11 feet for 20-85 ton units and 12 feet for 90-110 tons. Chains must not bear on top of unit.
3. Do not use hooks to lift unit. Do not hook into open channels to lift unit. Loop chain through lifting lug. See detail in [Figure 3, p. 18](#) and [Figure 17, p. 28](#).
4. Lift using overhead crane only. Adjust rigging for unit center of gravity.
5. Unit center of gravity will fall within center of gravity block at various locations depending on unit options.
6. See unit nameplate for unit weights.
7. Do not stack units.

Table 23. Gravity Block Dimensions 20-80 tons, in.

Unit Size	A	B	C
20-35	25	32	38
42-80	33	34	50

Figure 17. Detail of how to loop chain through lifting lug on self-contained

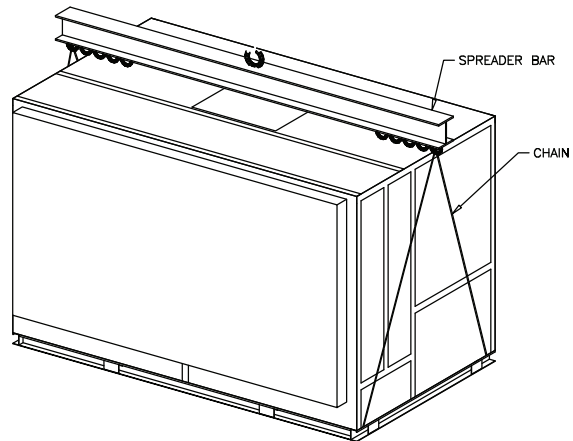

Figure 18. Gravity block location and dimensions for 20-80 ton units

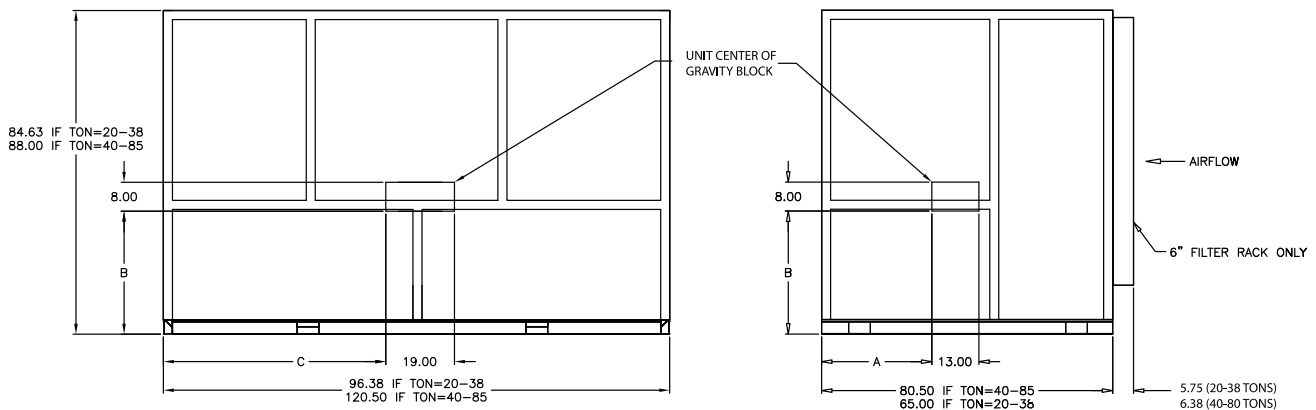
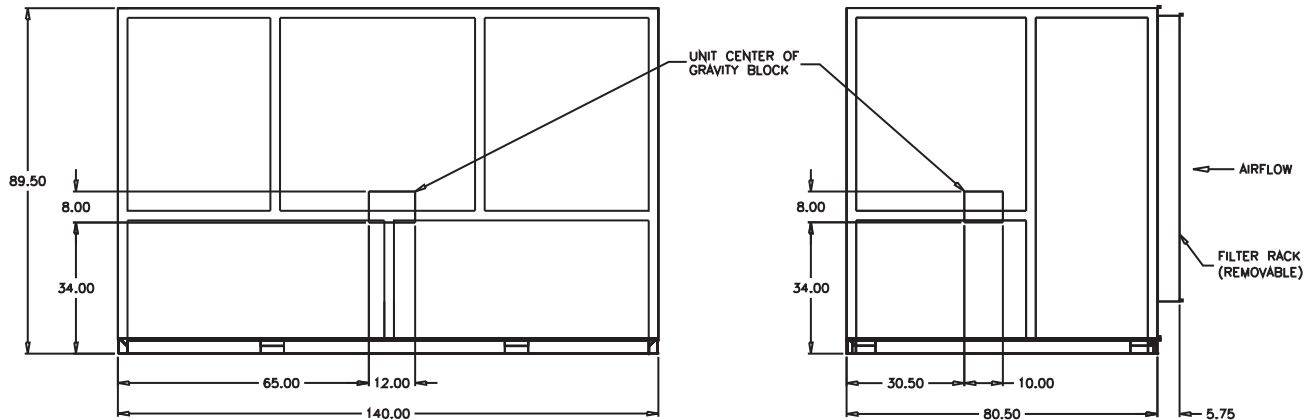

Figure 19. Gravity block location and dimensions for 90-110 ton units

Installation Preparation

Before installing the unit, perform the following procedures to ensure proper unit operation.

1. Position the unit and skid assembly in its final location.
2. Test lift the unit to determine exact unit balance and stability before hoisting it to the installation location. See "Unit Handling Procedure," p. 28 for proper rigging procedures and cautions.
3. Remove the skids from under the unit. See Figure 3, p. 18. Refer to the "Skid Removal" section. If you find internal damage, file a claim immediately to the delivering carrier.
4. Remove the protective shipping covers from the unit.
5. Verify isolators are properly tightened for operation. See "Unit Vibration Isolator Option," p. 29.
6. Tighten compressor isolator mounting bolts. Torque to 18 ft. lbs. (+ 2 ft. Lbs.)

Unit Vibration Isolator Option

Important: *Vibration isolation is not necessary for the unit since the factory internally isolates the fan and compressors, thus creating double isolation. Trane strongly recommends that you consult a vibration specialist when considering double isolation. In general, Trane does not recommend double-isolation.*

If job requirements dictate unit isolators, use a housed-spring isolator with a locating pin. Factory-provided unit isolators are type CP and indicate the spring number on the outer housing. See Figure 20, p. 29. Set the spring-type vibration isolators in position before completing electrical, piping, or duct connections. The 20-38 ton units require four isolators per unit, and the 40-80 ton units require six isolators per unit. Reference the isolator placement sheet that ships with the isolators to indicate proper placement.

Unit Isolator Installation Procedure

Follow the procedure below to install isolators:

1. Position the isolators under the unit base referring to the isolator placement sheet that ships with the unit isolators. Lift one end of the unit at a time to position the isolators. Fasten the isolators to the floor using anchor bolts.
2. Level the unit by adjusting the isolator heights. Unit weight may cause the upper housing of the spring isolators to rest on the lower housing. Maintain clearances between 1/4 and 1/2". To increase the clearance, lift the unit off the isolator and turn the leveling bolt counterclockwise. Verify that the unit is level and the housing clearances are correct. The maximum allowable difference between isolator heights is 1/4". Shim as required under the isolators.

Note: *The unit is equipped with a positively sloped drain pan to help indoor air quality (IAQ) and does not require one corner of the unit to be pitched.*

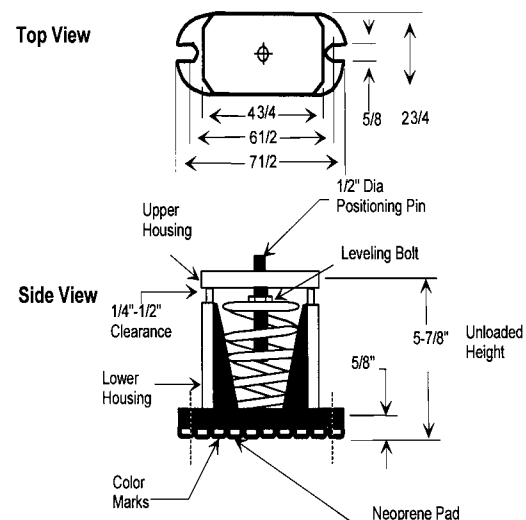
Figure 20. Optional spring-flex vibration isolator (type CP-1) for unit isolation

Duct Connections

Return air enters the rear of the unit and conditioned supply air discharges through the top. Attach supply air ductwork directly to the unit's top panel, around the fan discharge opening. A duct collar is not provided.

Note: Units equipped with flexible horizontal discharge plenum option may include a duct collar when holes are factory cut. If discharge openings are field-cut, refer to the "Plenum Installation" section.

Install all air ducts according to the National Fire Protection Association standards for the "Installation of Air Conditioning and Ventilation Systems other than Residence Type (NFPA 90A) and Residence Type Warm Air Heating and Air Conditioning Systems (NFPA 90B).

Make duct connections to the unit with a flexible material such as heavy canvas. If a fire hazard exists, Trane

Figure 21. Duct connection recommendations

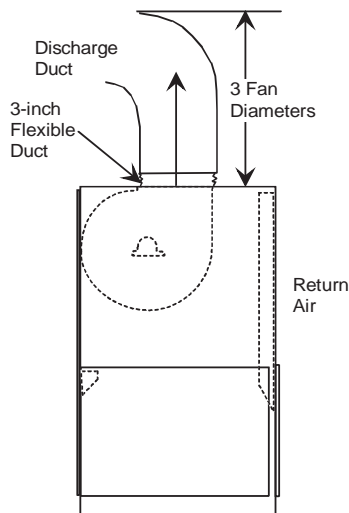

recommends using Flexweave 1000, type FW30 or equivalent canvas. Use **three inches** for return duct and **three inches** for discharge duct. Keep material loose to absorb fan vibration.

Note: Compressors and fan assembly are internally isolated. External isolation devices (spring mounting isolators) are at discretion of a vibration specialist consulted by building or HVAC system designer.

- If using return ductwork to the unit, secure it with three inches of flexible duct connector.
- Extend discharge duct upward without change in size or direction for at least three fan diameters.
- Use 3" flexible duct connection on discharge ductwork.

Run the ductwork straight from the opening for a minimum of three fan diameters. See [Figure 21, p. 30](#). Extend remaining ductwork as far as possible without changing size or direction. Do not make abrupt turns or transitions near the unit due to increased noise and excessive static losses. Use elbows with splitters or turning vanes to minimize static losses.

Poorly constructed turning vanes may cause airflow generated noise. Align the fan outlet properly with the ductwork to decrease noise levels in the duct and to increase fan performance. To complete trunk ductwork to the VAV terminal units, refer to the VAV box manuals for specific requirements. Check total external static pressures against fan characteristics to be sure the required airflow is available throughout the ductwork.

To achieve maximum acoustical performance, minimize the duct static pressure setpoint

Plenum

Before installing plenum, attach insulation strip that ships with plenum. See [Figure 22, p. 30](#) for proper insulation location. Align plenum front with control panel side of unit. Using strips and screws provided, secure plenum to unit. Treat field-cut holes to prevent fiberglass from entering the airstream.

Note: Plenum insulation must be applied properly to prevent air bypass around the plenum. See [Figure 22, p. 30](#).

Figure 22. Correct plenum insulation placement

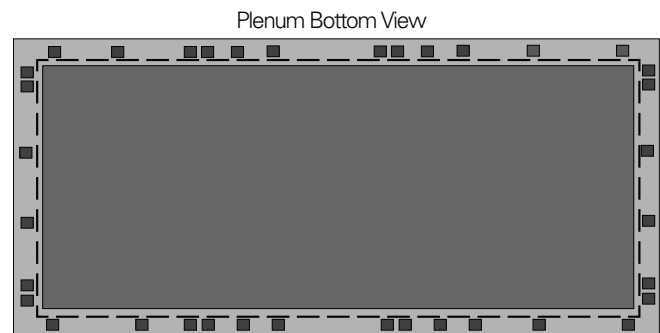

Dashed line indicates correct insulation placement.

Airside Economizer Installation

Note: Airside economizer option available on 20-80 tons only.

Economizer Handling

1. Hoist the damper cabinet to the installation location with straps positioned under the skid as shown in Figure 23, p. 31. Use spreader bars to prevent unit damage during lifting.
2. With the damper cabinet at its final location (near the unit), remove the screws securing it to the skid from the side flanges. Retain these screws for later use.

Economizer Preparation

3. Open the access door and remove the damper cabinet's support legs and its hanging bracket. The support legs are secured to the skid, and the hanging bracket is secured with wire ties to an inside flange near the cabinet's base. Remove the C-channel collar and install it on the unit, if not already installed.
4. Remove the roll of 1/8" thick gasket from the damper cabinet's W-supports, and apply it to the C-channel collar mounted on the rear of the unit. This gasket will provide a seal between the damper cabinet and the unit.
5. Attach the legs (with screws provided) to the leg brackets located on the damper's base.
6. Attach a field-provided clevis of suitable strength (> 1/2"), to each of the corner lifting brackets through the 7/8" diameter holes.
7. Attach to the clevises a means of lifting the damper cabinet from its skid.

Economizer Installation

8. Slowly raise the damper cabinet from its skid.
9. Attach the hanging bracket across the front of the damper cabinet. Position it with its short flange pointing to four o'clock, and secure it with screws provided. See Figure 23, p. 31.
10. Lift the damper cabinet and position it such that the hanging bracket is positioned over the unit's C-channel collar.
11. Lower the damper cabinet until the holes in its side flanges are aligned with the holes in the C-channel collar. Install screws removed in step 3 through the damper cabinet's side flanges and into the C-channel's corresponding holes.
12. Attach ductwork to the top and back dampers according to local codes.

Field Wiring Connections

⚠ WARNING

Proper Field Wiring and Grounding Required!

All field wiring **MUST** be performed by qualified personnel. Improperly installed and grounded field wiring poses **FIRE** and **ELECTROCUTION** hazards. To avoid these hazards, you **MUST** follow requirements for field wiring installation and grounding as described in **NEC** and your local/state electrical codes. Failure to follow code could result in death or serious injury.

13. Open the damper cabinet's door and connect the **factory-provided plug** from the actuator to the **factory-provided plug** in the unit's filter section.
14. **Cabinets with TRAQ dampers only:** Unroll two rolls of pneumatic tubing located inside damper cabinet. Route tubes through cabinet's front upper panel (0.25 dia. holes provided). Connect to two pneumatic tubes protruding from customer electrical connection panel on unit. Be sure to connect black to black, white stripe to white stripe).
15. **Cabinets with TRAQ dampers only:** Locate the "bullet" sensor and rolled up wiring in the unit's filter section. Route it into the damper cabinet and insert the sensor into the sensor mounting clip attached to underside of one of the Traq dampers.

Figure 23. Proper lifting of the airside economizer (top) and airside economizer option (bottom)

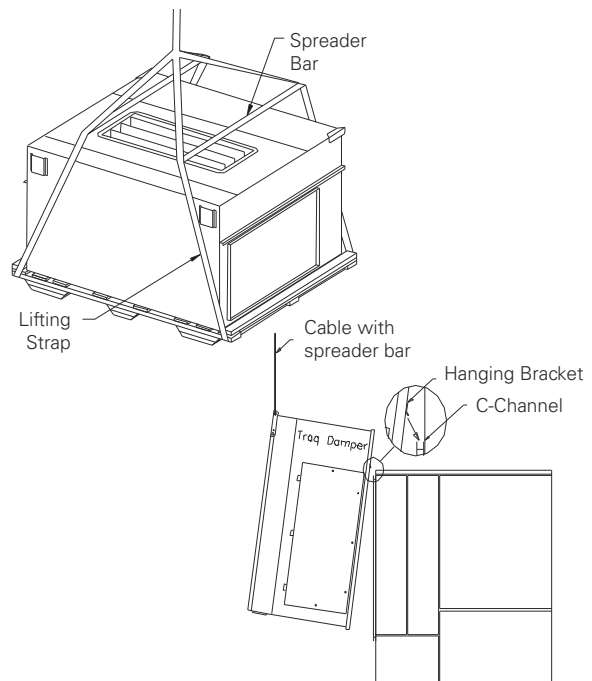

Water Piping

Condenser Connections

⚠ WARNING

High Pressure Water!

Provide relief valves on system water piping to prevent instantaneous release of high pressure water. Failure to provide relief valves could result in death or serious injury or water pump damage or unit failure.

NOTICE:

Proper Water Treatment Required!

The use of untreated or improperly treated water in coils could result in scaling, erosion, corrosion, algae or slime. It is recommended that the services of a qualified water treatment specialist be engaged to determine what water treatment, if any, is required. Trane assumes no responsibility for equipment failures which result from untreated or improperly treated water or saline or brackish water.

Condenser water piping knockouts are in the lower left end panel. If necessary, remove insulation to gain access. All field installed piping must conform to applicable local, state, and federal codes. To complete condenser water connections follow the procedure below.

Note: Four condenser waterline drain plugs ship in a bag in the unit's left end. The installer must field install these four plugs using pipe thread sealer. An additional plug is provided for units with a waterside economizer.

1. Install vent plugs in economizer coil headers and condenser manifolds. See [Figure 24](#). These plugs ship in a bag with the condenser drain plugs.

Figure 24. Economizer coil vent and condenser cleanout/drain plugs.

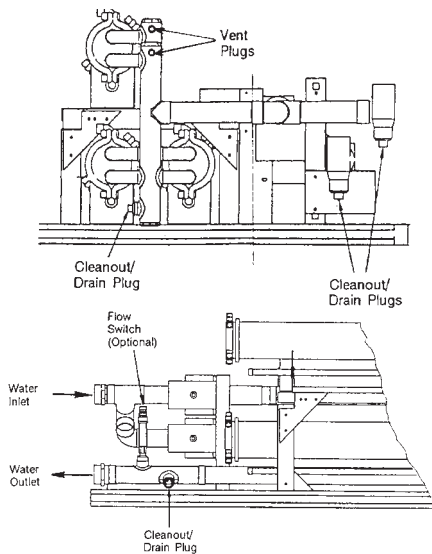

2. Attach the water supply line to the inlet connection, and the return line to the outlet connection. Entering and leaving water connections for all condensers are factory manifolded and require only single connections for entering and leaving water. If the unit has a waterside economizer and/or control valves, the factory pipes between these components.
3. If using a cooling tower, refer to [Figure 25, p. 33](#) for a typical piping circuit from the unit.
4. Ensure water pressure to unit doesn't exceed 400 psig.

Note: To prevent water pump damage, design system piping to provide relief when using energy saving waterside economizer valves.

Condensate Drain Connections

The condensate drain is internally trapped. Condensate drain connections are on the unit's left side.

Connect condensate drain piping to the 1 1/4" NPT female fitting, using at least 7/8" OD copper or 3/4" OD iron pipe. Pitch the condensate line downward a minimum of 1/2" for each 10' of horizontal run, away from the unit. Install the condensate drain "P" trap drain plug. Before starting the unit, fill the trap with water to prevent negative pressure in the fan section from impeding condensate flow. To facilitate drain pipe cleaning, install plugged tees in place of 90° elbows.

General Waterside Recommendations

Cooling Towers

Cooling tower control affects the unit cycle rates. Condenser water temperature swings from 10-15°F may cause excessive compressor, water valve, and unit cycling. Be sure to set the tower controls to minimize compressor/unit cycling.

Waterside Piping Arrangements

Install a condenser water pump between cooling tower (either open or closed) and self-contained unit. Lay out the remainder of system's condenser piping in reverse returns. This helps balance the system by equalizing the length of supply and return pipes. Multistory buildings may use a direct return system with balancing valves at each floor.

Install supply riser and its return in close proximity. Furnish both with permanent thermometers to check the waterside balance during start-up and routine maintenance checks.

Also, include strainers at each pump inlet and unit. Install drain valves at the riser's base to allow drainage points for system flushing during start-up and routine maintenance. For condenser draining and header removal, include a shutoff/balancing valve on the entering and leaving waterside pipes, drain tees, and unions of each unit. Also, install a shutoff valve on the unit entering water pipe for condenser draining.

Note: Unit does not have floor drains.

Water Temperature Requirements

Do not allow the entering water temperature to go below 54°F (12.2°C) on units with constant water flow (basic piping). This will cause the compressors to shut down and the mechanical cooling function will lockout. However, the economizer (if enabled) will continue to function. The compressors will reset when the entering water temperature reaches 58°F (15°C).

Units with variable water flow (intermediate piping) have a modulating condensing pressure control valve that allows compressor operation down to entering water temperatures of 35°F (2°C).

For more information on constant and variable water flow, see the Sequence of Operation section of this manual.

Note: Units with waterside economizer can be set from human interface panel for variable or constant water flow.

Figure 25. Condenser water piping components for cooling tower system

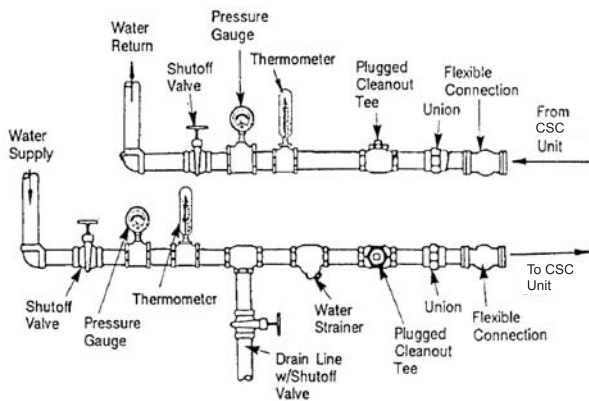

Water Piping Verification

- Make return and supply water connections to the unit and/or waterside economizer piping package with recommended valves and piping components.
- Install unions to allow waterside maintenance.
- Install cooling tower and standby pumps.
- Treat water to prevent algae, slime, and corrosion.
- Prevent refrigerant piping from rubbing against other objects.

Hydronic Coil Installation

Steam and Hot Water Coil

⚠ WARNING

Unit Structural Integrity!

Unit panels provide structural integrity. Do not remove more than two non-adjacent panels at one time as this could cause the plenum frame to collapse. Failure to follow these recommendations could result in death, serious injury or equipment damage.

Note: Hydronic coil options are available only on 20-80T units and can be field or factory mounted.

1. Position the coil box behind the unit with open side facing the unit inlet.
2. An envelope containing the gasket and mounting screws to attach the coil to the unit ships in the bottom of the unit. Install the pressure sensitive gasket to the unit side of the vertical flange on the coil box in two places.
3. Before attaching the coil box, connect the coil duct static pressure tube. This must be done before the coil box is bolted to the unit. If the unit connection does not have a static pressure tube, then no connection is required.
4. Apply edge protector to the flange on unit. Remove knockout on the unit filter cover and install the bushing in the plastic bag. Run the wires through the bushing and connect wires to the unit.
5. After connecting wires and the static pressure tube, raise the coil box up against the unit and install the mounting screws. Recommended lifting points are at each end of the coil box.
6. Avoid routing wires over devices and sharp edges. Use wire ties about every 12 inches to secure wires to other wire harnesses.
7. Move the entering air temperature sensor upstream of the coil to ensure proper operation.

Refrigerant System

Trane Water Cooled Commercial Self Contained units ship factory charged with R-410A refrigerant.

Trane Air Cooled Commercial Self Contained and Condenser units ship with a dry nitrogen holding charge.

Before installing refrigerant piping verify holding charge is present. Momentarily depress the CSC suction or discharge line (and Condenser liquid line) access port valves.

If charge is present continue with piping installation.

If no nitrogen escapes the access valve, leak test the unit refrigerant system to determine the leak source, and repair. See Maintenance section, "Refrigerant Leak Test Procedure," p. 84. After finding leak, remove test pressure



Installation - Mechanical

and repair leak using proper brazing procedures. See Maintenance section, “[Brazing Procedures](#),” p. 85. Retest unit(s) to ensure all leaks are repaired. Continue with piping installation.

Interconnecting Piping

Refrigerant piping must be properly sized and applied. These two factors have a significant effect on both system performance and reliability.

Using [Table 24, p. 34](#), select proper liquid and discharge line size. Unit connection sizes are also shown. Install interconnecting piping using proper installation and brazing procedures.

Work on only one circuit at a time to minimize system exposure to potentially harmful moisture in the air.

Before installing piping verify compressor oil levels are near top of sight glass or above.

Note: CSC units (and replacement compressors) ship fully charged with POE oil from the factory. Scroll compressors use POE oil (OIL00079, quart container or OIL00080, gallon container), DO NOT substitute.

Capped discharge and liquid line connections are located near bottom, left side of the indoor unit. CCRC/CIRC connections are located in the unit front, at top.

Remove caps with a tube cutter to minimize risk of getting chips inside piping.

Note: When facing control panel side of unit, Circuit #2 is always on left and Circuit #1 on the right.

Cleanliness is extremely important during system installation to minimize residual contaminants, such as oxidization and scale.

Attach vacuum pump and begin evacuation as soon as piping installation is complete. This starts system dehydration and helps prevent POE compressor oil contamination. This will also indicate large leaks if vacuum does not hold (below 400 microns and hold for 2 hours). Complete LeakTest and Evacuation (for procedures, see “[Refrigerant Leak Test Procedure](#),” p. 84 and “[System Evacuation Procedures](#),” p. 86 in Maintenance section) before starting “[Preliminary Refrigerant Charging](#),” p. 35.

Note: Installation of a field supplied discharge line access port near indoor units with optional discharge line ball valve will make high side pressure measurements easier during leak test.

Note: Use Type “L” refrigerant grade copper tubing only.

NOTICE:

Equipment Damage!

Compressors contain POE oil which readily absorbs moisture directly from the air. Moisture absorbed by POE oil is very difficult to remove by evacuation and can cause compressor failure. To prevent contamination, this unit shipped sealed containing dry nitrogen. Minimize the amount of time the system is open to the atmosphere. When open, flow dry nitrogen through the piping to prevent atmospheric moisture from contacting compressor POE oil.

Table 24. Refrigerant piping sizes

Air Cooled Signature Connection Size (in)				
SXRF Size	Circuit 1		Circuit 2	
	Liquid	Discharge	Liquid	Discharge
20, 25, 29	5/8	7/8	5/8	7/8
30, 35, 40, 50	7/8	1 3/8	5/8	7/8
60	7/8	1 3/8	5/8	7/8

Remote Condenser Connection Size (in)				
CXRC Size	Circuit 1		Circuit 2	
	Liquid	Discharge	Liquid	Discharge
20, 29	5/8	7/8	5/8	7/8
35, 40, 50	7/8	1 3/8	5/8	7/8
60	7/8	1 3/8	5/8	7/8

Interconnecting Tube Size (in)				
SXRF/CXRC Size	Circuit 1		Circuit 2	
	Liquid	Discharge	Liquid	Discharge
20/20	5/8	7/8	5/8	7/8
25/29	5/8	1 1/8	5/8	7/8
29/29	5/8	1 1/8	5/8	7/8
30/35	7/8	1 1/8	5/8	7/8
35/35	7/8	1 1/8	5/8	7/8
40/40	7/8	1 3/8 ^(a)	5/8	7/8
50/50	7/8	1 3/8	5/8	1 1/8
60/60	7/8	1 3/8	7/8	1 3/8

(a) Use 1 1/8" for vertical risers.

Preliminary Refrigerant Charging

⚠ WARNING

Confined Space Hazards!

Do not work in confined spaces where refrigerant or other hazardous, toxic or flammable gas may be leaking. Refrigerant or other gases could displace available oxygen to breathe, causing possible asphyxiation or other serious health risks. Some gases may be flammable and or explosive. If a leak in such spaces is detected, evacuate the area immediately and contact the proper rescue or response authority. Failure to take appropriate precautions or to react properly to such potential hazards could result in death or serious injury.

⚠ WARNING

Hazard of Explosion!

Use only dry nitrogen with a pressure regulator for pressurizing unit. Do not use acetylene, oxygen or compressed air or mixtures containing them for pressure testing. Do not use mixtures of a hydrogen containing refrigerant and air above atmospheric pressure for pressure testing as they may become flammable and could result in an explosion. Refrigerant, when used as a trace gas should only be mixed with dry nitrogen for pressurizing units. Failure to follow these recommendations could result in death or serious injury or equipment or property-only damage.

⚠ WARNING

Hazardous Pressures!

If a heat source is required to raise the tank pressure during removal of refrigerant from cylinders, use only warm water or heat blankets to raise the tank temperature. Do not exceed a temperature of 150°F. Do not under any circumstances apply direct flame to any portion of the cylinder. Failure to follow these safety precautions could result in a violent explosion, which could result in death or serious injury.

⚠ CAUTION

Freezing Temperatures!

Do not allow liquid refrigerant to contact skin. If it does, treat the injury similar to frostbite. Slowly warm the affected area with lukewarm water and seek immediate medical attention. Direct contact with liquid refrigerant could cause minor or moderate injury.

NOTICE:

Compressor Damage!

If it becomes necessary to remove or recharge the system with refrigerant, it is important that the following actions are taken. To prevent cross contamination of refrigerants and oils, use only dedicated R-410A service equipment.

- Disconnect unit power before evacuation and do not apply voltage to compressor while under vacuum.
- Due to presence of POE oil, minimize system open time. Do not exceed 1 hour.
- Allow the crankcase heater to operate a minimum of 24 hours before starting compressors.
- Do not allow liquid refrigerant to enter the suction line. Excessive liquid accumulation in the liquid lines could result in compressor damage.
- Do not operate the compressors without some refrigerant in each circuit.

Failure to follow these instructions could result in compressor failure.

To charge the system:

1. Verify system leak check (including interconnecting piping for air cooled systems) and evacuation are complete before adding refrigerant. See "[Refrigerant Leak Test Procedure](#)," p. 84 and "[System Evacuation Procedures](#)," p. 86 in Maintenance section
2. Ensure field supplied unit disconnect is "OFF". Verify that the unit 115 volt control circuit switch is "OFF" and reset relays have been unplugged, to prevent inadvertent compressor starts.
3. Turn field supplied unit disconnect "ON" to energize crankcase heaters. Verify crankcase heaters are operating.
4. Verify all service valves are open.
5. See CSC General data [Table 1](#), p. 11, [Table 2](#), p. 12 or [Table 5](#), p. 14 for unit refrigerant charge.
6. See [Table 25](#), p. 36 for additional charge required based on field piping size and length. Add this to the charge amount from [Step 5](#) for the total charge.

Note: *Step 6 not required for field piping under 25 feet, or for water cooled system.*

7. At the liquid line angle valve add as much R-410A LIQUID as possible up to, but not exceeding, total charge amount. Depending on conditions, it may not be possible to add more than 60% of the total charge. This will be adequate for compressor startup. More charge will be added after compressors are started. Use an accurate scale to measure and record preliminary amount of R-410A added to each circuit.
 - **Air Cooled Only:** Add charge at the condenser access valve or field supplied discharge line access valve. If angle valve is used for charging, liquid line solenoid valve should be open.



Installation - Mechanical

8. DO NOT add refrigerant in the suction line during preliminary charging to minimize refrigerant in system low side prior to compressor start.
9. Record charge amount added.
10. If total charge is not reached see ["Final Refrigerant Charge," p. 76.](#)
11. Verify wiring has been returned to original.
 - **Air Cooled Only:** Verify liquid line solenoid valve has been returned to original.

Table 25. Charge add (R-410A) - lbs per 10 ft of line^(a)

Piping Size (in)	Charge (lbs)	
	Liquid Line	Discharge Line
5/8	1.07	-
7/8	2.23	0.31
1 1/8	-	0.53
1 3/8	-	0.80

(a) Amounts listed are for 10 ft of pipe above 25'. Actual requirements will be in direct proportion to the actual length of piping.

Installation - Electrical

Unit Wiring Diagrams

Specific unit wiring diagrams are provided on the inside of the control panel door. Use these diagrams for connections or trouble analysis.

Supply Power Wiring

It is the installer's responsibility to provide power supply wiring to the unit terminal block or the non-fused disconnect switch option. Wiring should conform to NEC and all applicable code requirements.

Bring supply wiring through the knockout in the lower left side of the unit control panel. Connect the three phase wires to the power terminal block or the non-fused disconnect switch in the control box terminals. Refer to specific wiring diagrams and fuse information in the unit's control panel.

⚠ WARNING

Hazardous Service Procedures!

The maintenance and troubleshooting procedures recommended in this section of the manual could result in exposure to electrical, mechanical or other potential safety hazards. Always refer to the safety warnings provided throughout this section concerning these procedures. Unless specified otherwise, disconnect all electrical power including remote disconnect and discharge all energy storing devices such as capacitors before servicing. Follow proper lockout/tagout procedures to ensure the power can not be inadvertently energized. When necessary to work with live electrical components, have a qualified licensed electrician or other individual who has been trained in handling live electrical components perform these tasks. Failure to follow all of the recommended safety warnings provided, could result in death or serious injury.

NOTICE:

Use Copper Conductors Only!

Unit terminals are not designed to accept other types of conductors. Failure to use copper conductors could result in equipment damage.

NOTICE:

Motor Damage!

Correct phase sequence is critical. If phase sequence of the incoming line voltage is not correct, it may result in motor damage.

Voltage Range

Voltages must be within +- 10% the nameplate voltage. Ensure the unit voltage is balanced by measuring at the compressor terminals. Voltage imbalance on three phase systems can cause motor overheating and premature failure. Maximum allowable imbalance is 2.0%.

Voltage Imbalance

Read the voltage at the compressor terminals to determine if it is balanced. Voltage imbalance on three phase systems can cause motor overheating and premature failure. The maximum allowable imbalance is 2.0%. Voltage imbalance is defined as 100 times the sum of the deviation of the three voltages from the average (without regard to sign) divided by the average voltage. For example, if the three measured voltages are 221, 230, and 227, the average voltage would be:

$$\frac{(221 + 230 + 227)}{3} = 226 \text{volts}$$

The percentage of voltage imbalance is then:

$$100 * (226 - 221) / 226 = 2.2\%$$

Phase Monitor

Unit is equipped with phase monitor in control box. The phase monitor will protect against phase loss, imbalance and reversal of line voltage. If a fault occurs, the red LED will energize. While the fault condition is present, the phase monitor interrupts the 115V control circuit. If no faults are observed, a green LED will be energized.

Control Power

In this example, 2.2% imbalance is not acceptable. Whenever a voltage imbalance of more than 2.0% exists, check the voltage at the unit disconnect switch. If the imbalance at the unit disconnect switch does not exceed 2.0%, faulty unit wiring is causing the imbalance. Conduct a thorough inspection of the unit electrical wiring connections to locate the fault, and make any repairs necessary.

Access the connection terminal block through the control panel on the unit's upper left side. All wiring should conform to NEC and applicable local code requirements.

Be sure all wiring connections are secure. Reference the unit specific diagrams inside the control panel.

Note: Unit transformers IT1, IT3, 1T4, and IT5 are sized to provide power to the unit only. Do not use these transformers to supply power to field equipment. Field connections to these transformers may create immediate or premature component failures.



Installation - Electrical

Selection Procedures

RLA = rated load amps

Compressor LRA = locked rotor amps

Fan motor LRA = locked rotor amps, N.E.C. table 430 - 150

FLA = full load amps, N.E.C.

Table 430 - 150

Voltage utilization range is $\pm 10\%$

Determination of minimum circuit ampacity (MCA).

MCA = 1.25 x largest motor amps/VFD amps (FLA or RLA) + the sum of the remaining motor amps.

Determination of maximum fuse size (MFS) and maximum circuit breaker size (MCB).

MFS and MCB = 2.25 x largest motor amps (FLA or RLA) + the sum of the remaining motor amps.

For units with the dual power option, there are two electrical circuits that need calculations using the formulas above:

- circuit #1 - fans
- circuit #2 - compressors

If the rating value determined does not equal a standard current rating of over current protective device, use the next lower standard rating for the marked maximum rating.

Table 26. Number of compressors per unit

SCRF/SIRF	20	25 - 29	30 - 35	40	50	60	90	100	110	
SCWF/SIWF	20 - 25	29 - 32	35 - 38	42 - 46	52 - 58	65 - 72	80	90	100	110
10	2	1	3	2	-	1	-	-	2	-
15	-	1	-	1	3	3	4	5	4	6

Table 27. Compressor Electrical Data

HP	SCWF/SIWF						SCRF/SIRF					
	200V		460V		575V		200V		460V		575V	
	RLA	LRA	RLA	LRA	RLA	LRA	RLA	LRA	RLA	LRA	RLA	LRA
10	41.4	267	18.6	142	15.8	103	41.4	267	18.6	142	15.8	103
15	56.9	351	25.5	197	23.1	146	56.9	351	25.5	197	23.1	146

Table 28. Fan motor electrical data

HP	TYPE	200V		460V		575V	
		FLA	LRA	FLA	LRA	FLA	LRA
5	OPD	15.7	107	6.7	48	5.4	40
	TEFC	15.0	125	6.7	52	5.3	41
7.5	OPD	22.3	199	9.7	84.8	7.8	61.4
	TEFC	23.2	162	9.4	74	7.6	58.5
10	OPD	29.5	260	12.6	118	10.1	72.3
	TEFC	27.4	195	11.9	103	9.6	83.9
15	OPD	43.4	271	18.9	118	15.1	94
	TEFC	42.5	235	18.5	122.9	14.8	99
20	OPD	57.0	373	24.5	160.8	19.6	130
	TEFC	56.4	320	24.5	175	19.6	140
25	OPD	70.0	438	30.5	180	24.5	155
	TEFC	69.0	385	30	200	23.9	153
30	OPD	82.2	514	36.6	223.6	28.5	179
	TEFC	82.8	566	37.6	274	28.8	210
40	OPD	111.6	740	48.5	302	38.0	250
	TEFC	106	734	47.4	320	38.0	280
50	ODP	N/A	N/A	60.5	380	47.0	305
	TEFC	N/A	N/A	59.0	455	47.2	380
60	ODP	N/A	N/A	71.0	470	N/A	N/A

Table 29. VFD electrical data

HP	VFD L.I.C.					
	Without Bypass			With Bypass		
	200V	460V	575V	200V	460V	575V
7.5	23.8	10.6	8.8	32.2	10.6	8.8
10	32.2	14	11.1	48.3	14	16.6
15	48.3	21	16.6	61.9	21	16.6
20	61.9	27.6	21.4	78.2	27.6	21.4
25	78.2	34	26.3	92	34	26.3
30	92	41	31.2	117	41	31.2
40	117	53	39.9	139.2	53	39.9
50	NA	64	50.6	n/a	64	50.6
60	NA	77	NA	n/a	77	n/a

Note: Values are at the maximum VFD input rating and not the reduced motor values. L.I.C. = Line Input Current.

Table 30. Single stage electric heat electrical data

SXWF Size	SXRF Size	Heat Kw	200V Amps	460V Amps
20	-	18	50	21.7
22	-	18	50	21.7
25	20	18	50	21.7
29	25	23	63.8	27.7
32	29	23	63.8	27.7
35	30	27	75	32.5
38	35	27	75	32.5
42	-	31.5	87.4	37.9
46	40	31.5	87.4	37.9
52	-	39	108.3	46.9
58	50	39	108.3	46.9
65	-	48	133.2	57.7
72	-	48	133.2	57.7
80	60	48	133.2	57.7

Note: Electric heat amperage should not be considered when determining minimum circuit ampacity. The current of the unit in the heating mode will not exceed the current of the unit in the cooling mode

Table 31. 2 stage electric heat electrical data

Unit Size SCWF	Heat kW	200V Amps	460V Amps	575V Amps
90	76	N/A	95.39	N/A
100	76	N/A	95.39	N/A
110	76	N/A	95.39	N/A

Static Pressure Transducer Installation (VAV units only)

Supply air static pressure controls inverter option. A static pressure head assembly ships separate in the control panel for field installation in the supply air duct work. The installer is responsible for providing pneumatic tubing.

Transducer Location

Place head assembly in an area of the ductwork that will provide an average and evenly distributed airflow pattern. Use the following guidelines to determine an appropriate installation location.

1. Locate the static head assembly about 2/3 to 3/4 of the way down the longest duct run, in an area approximately 10 duct diameters downstream and 2 duct diameters upstream of any major interferences, turns, or changes in duct diameter.
2. When installing pneumatic tubing between the head assembly and transducer in the control panel, do not exceed 250 feet for 1/4" OD tubing or 500 feet for 3/8" OD tubing.

Installing the Transducer

Complete the following procedure to properly install static pressure transducer.

1. Mount the pressure sensing head assembly in the duct so that the sensing tip is in the middle of the duct so that it will provide a proper pressure measurement. See [Figure 26, p. 39](#).
2. Connect the pneumatic tubing from the sensing head to the push-on tubing connection in the control panel. Use a plastic static pickup tubing. Do not exceed 250 feet for 1/4"OD tubing or 500 feet for 3/8" OD tubing.

The transducer inside the control panel picks up low side or reference pressure.

Note: If plastic tubing pulls away from a connection, trim it back before replacing it on the fitting. Stretched tubing may leak and cause faulty control

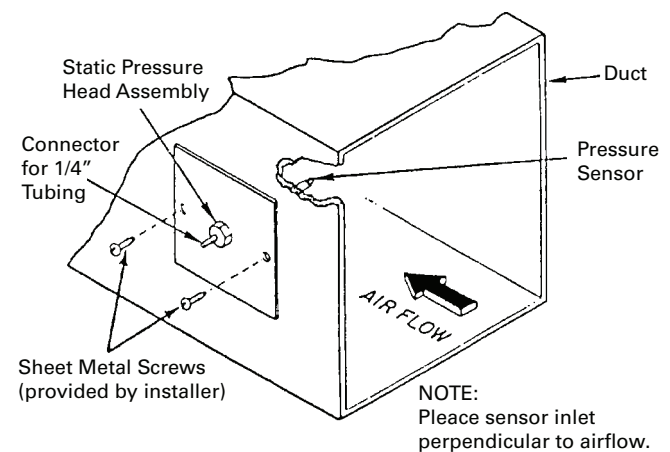
Figure 26. Static pressure sensor installation

Standard with All IntelliPak Units



BAYSENS077
(zone temperature sensor only)

CV Unit Zone Sensor Options



BAYSENS108
(Dual setpoint, manual/automatic changeover sensor, accessory model number digit 6 = E)



BAYSENS110
(Dual setpoint, manual/automatic changeover sensor with system function lights, accessory model number digit 6 = F)

Zone Sensor Options for IntelliPak™ Control Units

Zone sensor options are available and be ordered with the unit or after the unit ships. Following is a full description of zone sensors and their functions. Installation instructions are on page 46. Programming instructions for the programmable zone sensor are on page 49. See [Table 40, p. 65](#) for the zone sensor temperature vs. resistance coefficient curve.

BAYSENS077* Description

This zone sensor module ships with all units, and can be used with BAYSENS019, BAYSENS020, or BAYSENS021 remote sensors. When this sensor is wired to one of these remote zone sensors, wiring must be 18AWG shielded twisted pair (Belden 8760 or equivalent). Refer to the specific zone sensor for wiring details. It provides the following features and system control functions:

- Remote temperature sensing in the zone
- Morning warmup sensor
- Zone sensor for ICS™ systems
- Zone temperature averaging

When used as a remote sensor for standard zone sensor, the thermistor sensor must be disabled.

(Possible Schematic Designation(s): 5U23, 5U26, 5U30, and 5RT5.)

BAYSENS108 & BAYSENS110 Description

These zone sensor modules are for use with cooling/heating constant volume units. They have four system switch settings (heat, cool, auto, and off) and two fan settings (on and auto). The zone sensor provides either manual or automatic changeover control with dual setpoint capability.

BAYSENS108 and BAYSENS110 features and system control functions include:

- System control switch to select heating mode (HEAT), cooling mode (COOL), automatic selection of heating or cooling as required (AUTO), or to turn the system off (OFF).
- Fan control switch to select automatic fan operation while actively heating or cooling (AUTO), or continuous fan operation (ON).
- Dual temperature setpoint levers for setting desired temperature. The blue lever controls cooling, and the red lever controls heating.
- Thermometer to indicate temperature in the zone. This indicator is factory calibrated.

(Possible Schematic Designation: 5U29)

BAYSENS110-Specific Feature: Function status indicator lights:

- SYSTEM ON glows continuously during normal operation, or blinks if system is in test mode.
- COOL glows continuously during cooling cycles, or blinks to indicate a cooling system failure.
- HEAT glows continuously during heating cycles, or blinks to indicate a heating system failure.
- SERVICE blinks or glows to indicate a problem. These signals vary depending on the particular equipment being used.

(Possible Schematic Designation: 5U29)

CV and VAV Unit Zone Sensor Options

Integrated Comfort™ Systems Sensors for CV and VAV Applications

These zone sensor options are for use with cooling/heating Integrated Comfort System (ICS) systems.



BAYSENS074

(Zone temperature sensor w/timed override and local setpoint adjustment,

accessory model number digit 6 = (Possible Schematic Designation: 5U23)

C)

BAYSENS074 Description

This electronic analog sensor features single setpoint capability and timed override with override cancellation. BAYSENS074 features and system control functions include:

- Remote temperature sensing in the zone
- A timed override button to move an ICS or a building management system from its “unoccupied” to “occupied” mode.
- Thumbwheel for local setpoint adjustment
- A cancel button to cancel the “unoccupied override” command.



BAYSENS073

(Zone temperature sensor w/timed override, accessory model number digit 6 = B)

BAYSENS073 Description

This electronic analog sensor features single setpoint capability and timed override with override cancellation. It is used with a Trane Integrated Comfort system.

BAYSENS073 features and system control functions include:

- Remote temperature sensing in the zone
- A timed override button to move an ICS or a building management system from its “unoccupied” to “occupied” mode.
- Cancel button to cancel the “unoccupied override” mode.

(Possible Schematic Designation: 5U23)

Figure 27. Zone sensor mounting hole locations for: BAYSENS077, BAYSENS073, BAYSENS074, BAYSENS108, and BAYSENS110.

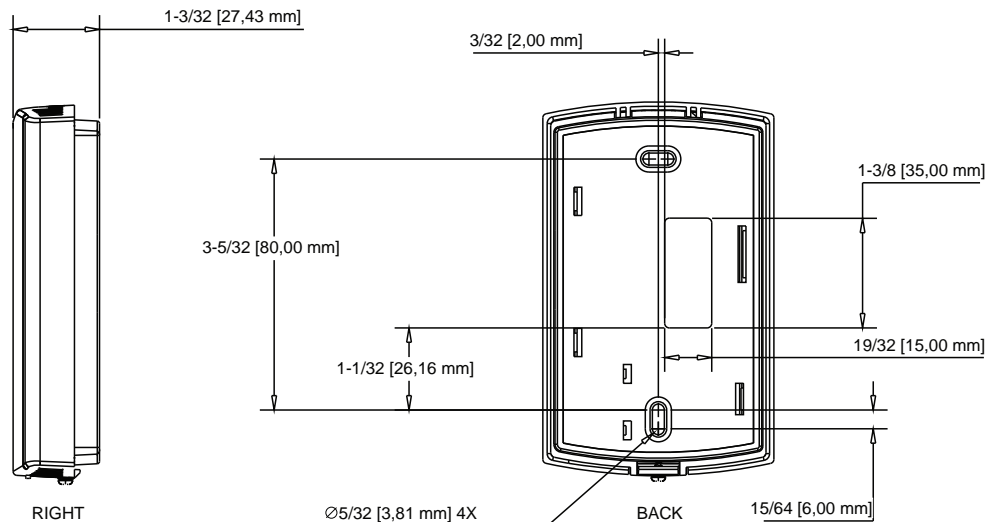

Zone Sensor Installation

⚠ WARNING

Hazardous Voltage w/Capacitors!

Disconnect all electric power, including remote disconnects and discharge all motor start/run capacitors before servicing. Follow proper lockout/tagout procedures to ensure the power cannot be inadvertently energized. For variable frequency drives or other energy storing components provided by Trane or others, refer to the appropriate manufacturer's literature for allowable waiting periods for discharge of capacitors. Verify with an appropriate voltmeter that all capacitors have discharged. Failure to disconnect power and discharge capacitors before servicing could result in death or serious injury.

For additional information regarding the safe discharge of capacitors, see PROD-SVB06A-EN

All sensor options ship in the main control panel and are field-installed. Programmable option installation procedures.

Mounting Location

Mount the sensor on the wall in an area with good air circulation at an average temperature. Avoid mounting space temperature sensor in areas subject to the following conditions:

- Drafts or "dead" spots behind doors or in corners
- Hot or cold air from ducts
- Radiant heat from the sun or appliances
- Concealed pipes and chimneys
- Unheated or non-cooled surfaces behind the sensor, such as outside walls
- Airflows from adjacent zones or other units

To mount the sensors, remove the dust cover and mount the base on a flat surface or 2" x 4" junction box. Sensors ship with mounting screws.

Mounting the Subbase

Remove the zone sensor cover from subbase, and mount subbase on the wall or on a 2 x 4 junction box. Route wires through the wire access hole in the subbase. See [Figure 28, p. 42](#). Seal the hole in the wall behind the subbase.

Note: Guidelines for wire sizes and lengths are shown in [Table 32, p. 42](#). The total resistance of these low voltage wires must not exceed 2.5 ohms per conductor. Any resistance greater than 2.5 ohms may cause the control to malfunction due to excessive voltage drop.

Note: Do not run low-voltage control wiring in same conduit with high-voltage power wiring.

Wiring

1. Run wires between the unit control panel and the zone sensor subbase. To determine the number of wires required, refer to the unit wiring diagrams.
2. Connect the wiring to the appropriate terminals at the unit control panel and at the zone sensor subbase. In general, zone sensor connections to the unit use the convention of connecting zone sensor terminals to like numbered unit terminals (1 to 1, 2 to 2, etc.). The connection detail is shown on the unit wiring diagrams, which are located in the unit control panel.
3. Replace the zone sensor cover back on the subbase and snap securely into place.

Standard Remote Sensor (BAYSENS077)

When using the remote sensor, BAYSENS077, mount it in the space that is to be controlled. Wire according to the interconnecting wiring diagrams on the unit.

Table 32. Zone sensor maximum lengths and wire size

Distance from Unit to Controller	Recommended Wiring Size
0-150 feet	22 gauge
151--240 feet	20 gauge
241-385 feet	18 gauge
386- 610 feet	16 gauge
611-970 feet	14 gauge

Figure 28. Typical zone sensor installation

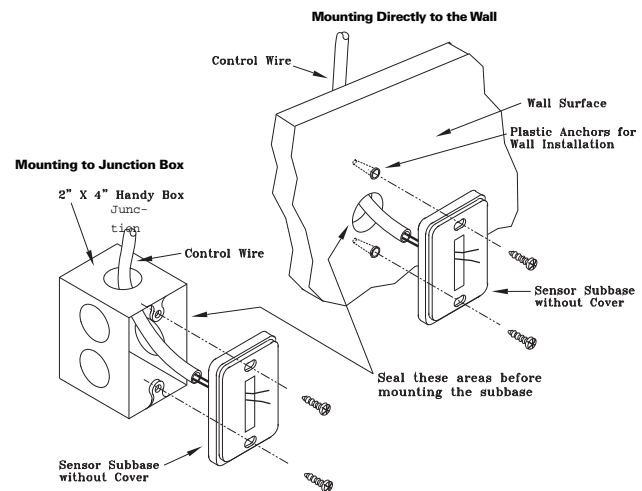

Programmable Zone Sensors



The BAYSENS119 programmable night set back sensor provides multi functional flexibility for both Constant Volume and Variable Air Volume control. This electronic programmable sensor includes auto or manual cooling and heating changeover with 7 day programming. Five tactile feel buttons located on the sensor front panel provide interface for all programming, including initial setup for CV or VAV control. Sensor functionality includes up to four daily programmable periods for Occupied/Unoccupied operation, and Override. The dynamic LCD display indicates status for System On/Off, Heat, Cool, Fan Status, Time of Day, Occupied/Unoccupied mode, Space Temperature, Space or Discharge Air Heating and Cooling Setpoints. Additional features include Service Indication for Heat Failure, Cool Failure, Fan Failure, and Test Mode if system is operating in test mode.

A Check Filter Timer function is included. Filter service countdown time can be set in one-day increments. Activation of the Test/Configuration button located on the bottom of the sensor performs a sensor self-diagnostic routine and indicates hours in service.

When the BAYSENS119 is programmed for Constant Volume or VAV control, Night Setback is initiated through the scheduled Unoccupied time setting. When the sensor switches to Night Setback, the outdoor dampers close and heating/cooling functions are enabled/disabled based on set up parameters. As building load changes, If heating/cooling functions are enabled, the Sensor energizes self-contained unit and evaporator fan operation. The unit will cycle heating/cooling operation throughout the Unoccupied period as required to maintain Unoccupied space temperature setpoints. When the Unoccupied time period has expired, all heating/cooling functions return to normal operation.

When Night Setback options are used with VAV heating/cooling, maintain airflow through the self-contained unit by electronically tying the VAV terminals to the unoccupied output relay contacts on the self-contained units low voltage terminal board, or by using changeover thermostats. Either of these methods will assure adequate airflow through the unit and satisfactory temperature control of the space.

Note: Refer to BAS-SVX17*-EN for complete Installation, Operation, and Maintenance Instructions.

Figure 29. Zone sensor mounting hole locations for: BAYSENS119

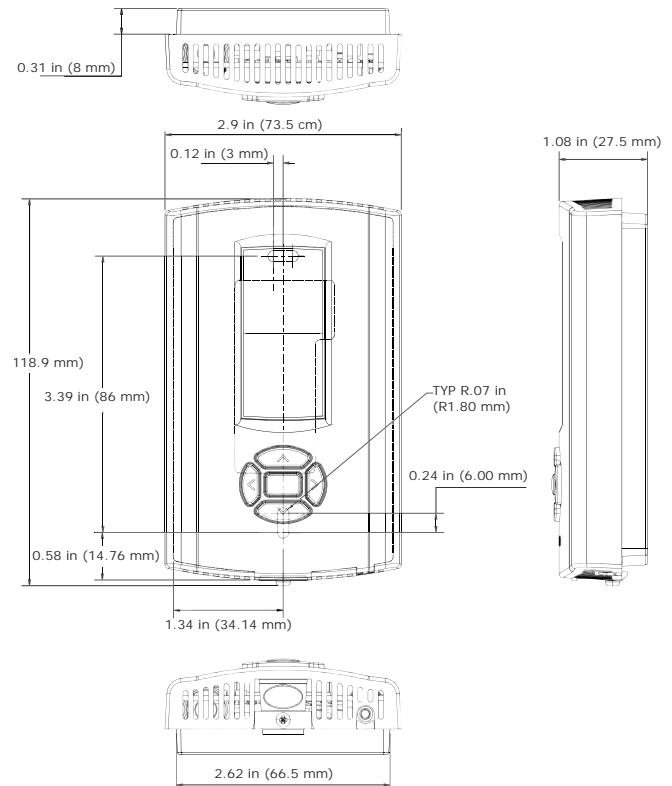

Time Clock Option

Figure 30. Grasslin time clock option



The time clock option has a programmable timer that is factory wired to the unoccupied input to provide on/off control. The time clock will not allow the unit to pass through the night setback/morning warmup mode, except on units with optional night heat/morning warm up, or programmable night setback. See [Figure 30, p. 44](#).

The time clock, a "Digi 20" by Grasslin, is inside the control panel, but accessible with the control panel door closed. This same type timer is also used for programmable night setback/morning warm up. Programming instructions for the "Digi 20" timer are in the "Programming" section.

Time Clock Installation

1. Ensure operating temperature is between 4°F and 131°F.
2. Locate the time clock at least 5 feet away from any large electrical contact or machinery to avoid possible electrical interference problems.
3. Provide a separate independent circuit for the time clock power supply.
4. Since all electronic instruments are sensitive to voltage spikes, pay close attention to the following:
 - a. If possible, supply power to the electronic time clock from a phase different than the one supplying power to the load.
 - b. Provide a suitable Varistor or RC network across the INDUCTIVE LOADS supply terminals to reduce voltage spikes.
 - c. Place a diode across the DC OPERATED INDUCTOR terminals to eliminate back EMF.
 - d. HIGHLY INDUCTIVE LOADS, especially fluorescent lights, may require a relay in which case (A) and (C) apply.

The time clock can be surface or flush mounted. Lift off the front cover and loosen the two screws on opposite corners. Pull off the base's plug with a left to right rolling motion.

Time Clock Installation Checklist

1. Ensure operating temperature is 4°F to 131°F.
2. Locate the time clock at least 5 feet away from any large electrical contact or machinery to avoid possible electrical interference problems.
3. Provide a separate independent circuit for the time clock power supply.
4. Since all electronic instruments are sensitive to voltage spikes, pay close attention to the following:
 - a. If possible, supply power to the electronic time clock from a phase different than the one supplying power to the load

The Digi 20A time clock unit can be surface or flush mounted. Lift off the front cover and loosen the two screws on opposite corners. Pull off the base's plug with a left to right rolling motion.

Surface Mounting Inside Panel

Place screws through the base's preset holes and screw to back of panel or wall.

Wire according to the instructions in the following section. Depending upon the specific installation, you may find it more convenient to complete wiring before attaching the base.

Place the terminal cover over the terminal block by aligning the two screws with the corner holes in the base. Push the timer firmly onto the plug in the base. Tighten the two screws. A base for DIN rail mounting is optional.

Wiring the Time Clock

1. Wire 24, 120, or 220 VAC to input terminals. Make sure to apply correct voltage. Using incorrect voltage will void the warranty.
2. Connect wire to the screw terminals according to the unit wiring diagrams. Use 12 to 22 AWG wire.

Remote Human Interface Panel Installation

⚠ WARNING

Proper Field Wiring and Grounding Required!

All field wiring **MUST** be performed by qualified personnel. Improperly installed and grounded field wiring poses **FIRE** and **ELECTROCUTION** hazards. To avoid these hazards, you **MUST** follow requirements for field wiring installation and grounding as described in **NEC** and your local/state electrical codes. Failure to follow code could result in death or serious injury.

Human Interface (HI) Panel

The HI enables the user to communicate necessary unit operating parameters and receive operating status information from within the occupied space.

The HI displays top level information in the LCD window, unless the operator initiates other displays, for the various unit functions. It also displays menu readouts in a clear language 2 line, 40 character format. The 16-key keypad allows the operator to scroll through the various menus to set or modify the operating parameters. See [Figure 31, p. 45](#) to reference the HI keypad.

Figure 31. Human interface (HI) panel keypad

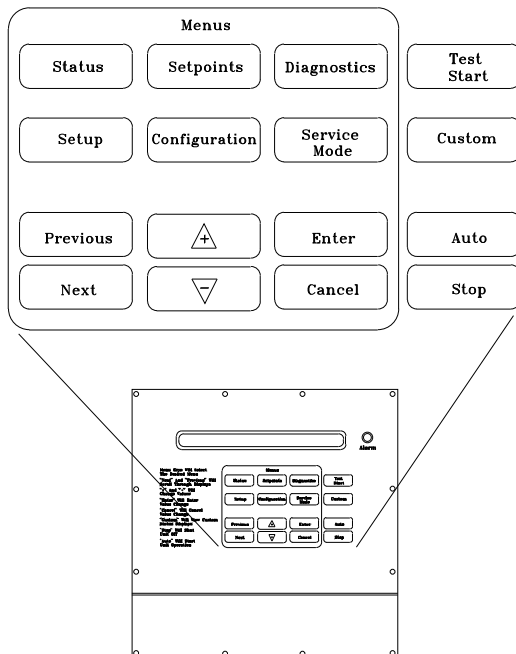

Remote Human Interface Panel

The remote human interface (RHI) panel is identical to the unit mounted HI with the exception of the “unit select” key.

This key allows the operator to switch from one unit to the next to program or view status information regarding a particular unit.

The RHI functions the same as the unit mounted HI with two exceptions. The first is the “test start” function. The operator can view the service parameters, but can only initiate the service test function at the unit. The RHI door has a locking screw to deter access by unauthorized personnel. Additionally, the RHI can control up to four different units.

Location Recommendations

The HI microprocessor module is mounted inside a molded plastic enclosure for surface mounting. It is not weatherproof. Therefore, it is only applicable for indoor use.

Locate the RHI panel in an area that will ensure the communication link between the panel and the unit(s) does not exceed 5,000 feet maximum or pass between buildings. See [Table 33, p. 45](#).

The run length of the low voltage AC power wiring to the remote HI must not exceed three (3) ohms/conductor. Refer to [Table 34, p. 45](#).

Table 33. Maximum communication link wiring length

Max. Wire Length	Max. Capacitance Between Conductors
1,000 ft	up to 60 pf/ft
2,000 ft	up to 50 pf/ft
3,000 ft	up to 40 pf/ft
4,000 ft	up to 30 pf/ft
5,000 ft	up to 25 pf/ft

Note: pf/ft = picofarads/foot

Ambient Temperature and Humidity Limits

Ambient Operating Conditions

- Temperature: 32 to 120°F
- Relative humidity: 10 to 90%, non-condensing

Ambient Storage Conditions

- Temperatures: -50 to 200°F
- Relative humidity: 5 to 95%, non-condensing

Table 34. Wiring recommendations for the remote HI panel

Distance to Remote HI	Recommended Wire Size
0-460 feet	18 gauge
461-732 feet	16 gauge
733-1000 feet	14 gauge

Mounting the Remote Human Interface (RHI) Panel

The installer must provide all mounting hardware such as; hand tools, electrical boxes, conduit, screws, etc. Refer to [Figure 32, p. 47](#) for the mounting hole and knockout locations.

Procedure

Refer to [Figure 32, p. 47](#) and follow the procedure below for mounting the remote HI panel on a 4" by 4" electrical junction box. Place the microprocessor in a clean dry location during the enclosure mounting procedures to prevent damage.

1. Mount an electrical junction box in the wall so that the front edge of the box will be flush with the finished wall surface.
2. Prior to mounting the panel, the microprocessor module must be carefully removed from the enclosure. To remove the module:
 - a. Lay the remote panel face up on a flat surface and remove the locking screw from the right hand bottom end of the panel.
 - b. Remove the recessed hinge screw from the left hand bottom end of the panel.
 - c. Unlatch the door of the enclosure as if to open it, and slide the left hand side of the door upward away from the hinge. Lay it aside.
 - d. With the key pad visible, remove the two (2) screws located on the right hand side of the key pad.
 - e. Carefully slide the key pad plate upward from the bottom, releasing the extruded hinge pin from its socket at the top.
 - f. Set the microprocessor aside until mounting is complete.
3. Remove the junction box knockout in the back of the enclosure.

Note: *The top of the enclosure is marked "TOP!"*

4. With the enclosure in the correct position; align the mounting holes around the knockout in the enclosure with the screw holes in the electrical handy box and secure with the appropriate screws.
5. Replace the microprocessor within the enclosure as follows:
 - a. Verify that the terminal block jumpers are connected properly.
 - b. Slide the extruded hinge pin at the top left of the key pad plate into the hole located at the top left hand side of the enclosure.
 - c. Slide the bottom of the plate into place, aligning the two (2) clearance holes with the screw holes on the right. Install the screws but do not tighten.

Note: *If the two screws are not installed as called out in the previous step, hold against the key pad plate while installing the door in the next step, to prevent it from falling out.*

- d. Slide the extruded hinge pin at the top left of the door into the hole located under the bottom left side of the display.
- e. Install and tighten the hinge screw located at the bottom left side of the enclosure.

Wall Mounting the RHI Panel

1. Prior to mounting the panel, the microprocessor module must be removed from the enclosure. Complete step 2 in the previous discussion, "Mounting on a 4 in. x 4 in. Electrical Box," before proceeding.
2. With the microprocessor removed, refer to [Figure 32, p. 47](#) for the location of the mounting holes to be used for wall mounting.
3. Place the enclosure against the mounting surface and mark the mounting holes.

Note: *The top of the enclosure is marked with "TOP!"*

4. With the enclosure in the correct position, remove the enclosure and drill the necessary holes in the surface for the appropriate fasteners, (plastic anchors, molly bolts, screws, etc.)
5. Remove the necessary knockouts for the wire or conduit entry before mounting the panel.
6. Place the enclosure back onto the surface and secure it with the appropriate screws.
7. Follow step 5 in the previous section, "Mounting on a 4" by 4" Electrical Box," to replace the microprocessor within the enclosure.

Figure 32. Remote HI mounting holes and knockout locations

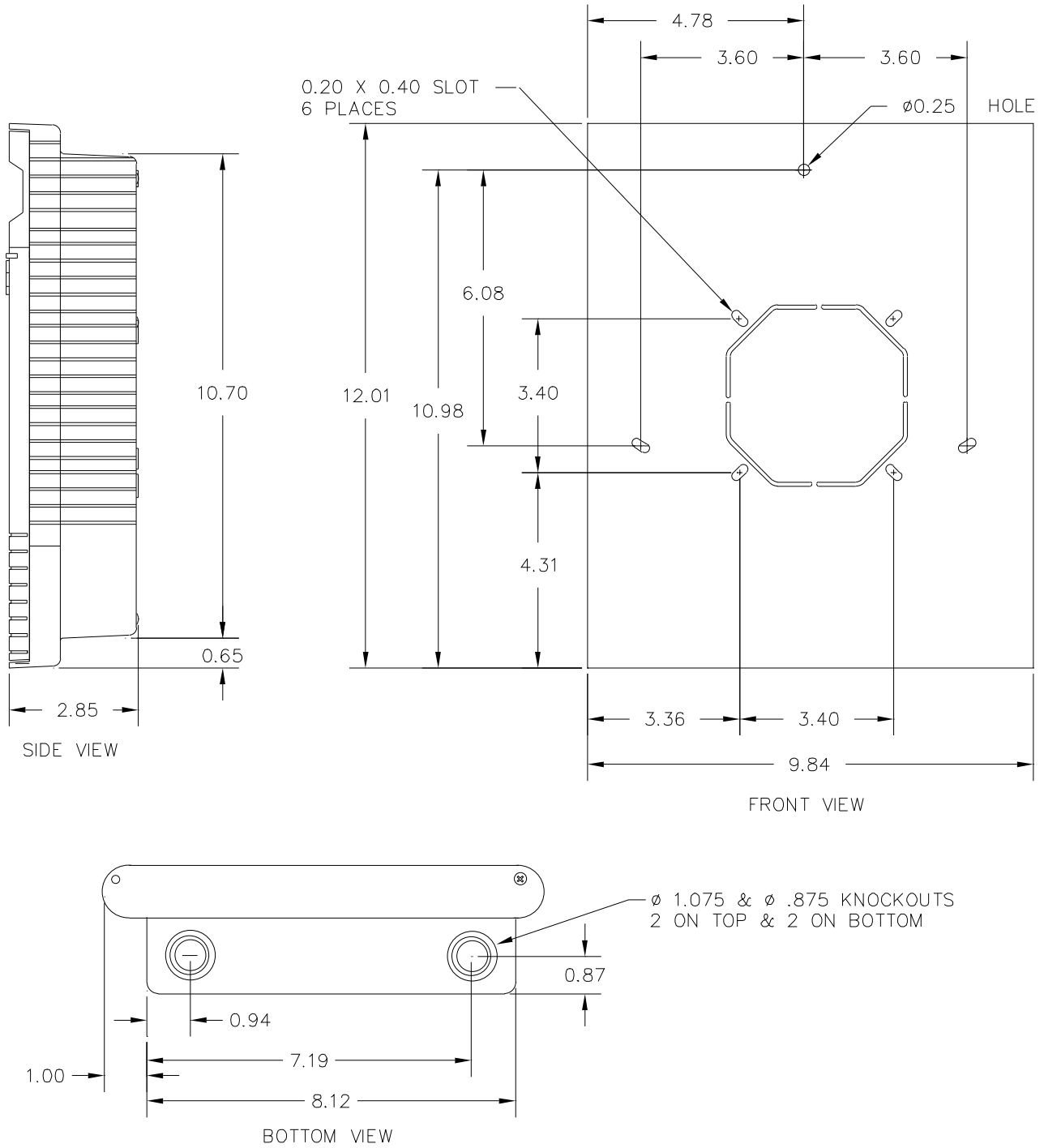

Wiring the Remote Human Interface

⚠ WARNING

Hazardous Voltage w/Capacitors!

Disconnect all electric power, including remote disconnects and discharge all motor start/run capacitors before servicing. Follow proper lockout/tagout procedures to ensure the power cannot be inadvertently energized. For variable frequency drives or other energy storing components provided by Trane or others, refer to the appropriate manufacturer's literature for allowable waiting periods for discharge of capacitors. Verify with an appropriate voltmeter that all capacitors have discharged. Failure to disconnect power and discharge capacitors before servicing could result in death or serious injury.

For additional information regarding the safe discharge of capacitors, see PROD-SVB06A-EN

The remote human interface requires 24 VAC + 4 volts power source and a shielded twisted pair communication link between the remote panel and the interprocessor communication bridge (ICPB) module at the self-contained unit.

Field wiring for both the low voltage power and the shielded twisted pair must meet the following requirements:

NOTICE:

Equipment Damage!

To prevent control malfunctions, do not run low voltage wiring (30 volts or less) in conduit with higher voltage circuits.

1. All wiring must be in accordance with NEC and local codes.
2. Reference [Table 34, p. 45](#) for recommended wiring distance and size.
3. Communication link wiring must be 18 AWG shielded twisted pair (Belden 8760, or equivalent).
4. Communication link must not exceed 5,000 feet maximum for each link. See [Table 33, p. 45](#)
5. Do not run communication link between buildings.

Low Voltage (AC) Field Wiring Connections

To access the wire entry locations, open the RHI panel door and remove the two screws on the right-hand side of the key pad. Swing the keypad open, exposing both the wire entries and the back of the HI module. Refer to [Figure 32, p. 47](#) and connect one end of the three conductor 24 volt wires to the remote panel terminal strip (+), (-), and (ground).

Communication Link (Shielded Twisted Pair) Wiring

Trim the outer covering of the shielded cable back approximately 1 inch. See [Figure 33, p. 49](#). Do not cut the bare shield wire off. Strip approximately 1/2-inch of insulation from each insulated wire to connect them to the terminal strip at the remote panel.

Connect the white lead to the positive (+) terminal, the black lead to the negative (-) terminal, and the bare shield wire to the terminal at the remote human interface panel.

Close the key pad plate. Install and tighten the two screws removed earlier. Close the outer door and install the recessed locking screw at the bottom right hand side of the enclosure to prevent accidental starting of the unit by unauthorized personnel while completing the wiring at the self-contained unit.

At the Self-Contained Unit

Connect the opposite end of the three conductor 24-volt wire to the appropriate terminal strip as follows:

Note: *Although the 24 volt power is not polarity sensitive, do not connect either the + (plus) or - (minus) terminals from the remote panel to ground at the self-contained unit.*

Connect the wire connected to the positive (+) terminal at the remote panel. Connect the wire connected to the negative (-) terminal at the remote panel. Connect the ground wire from the remote panel to the unit control panel casing.

Figure 33. Dressing shielded twisted wire

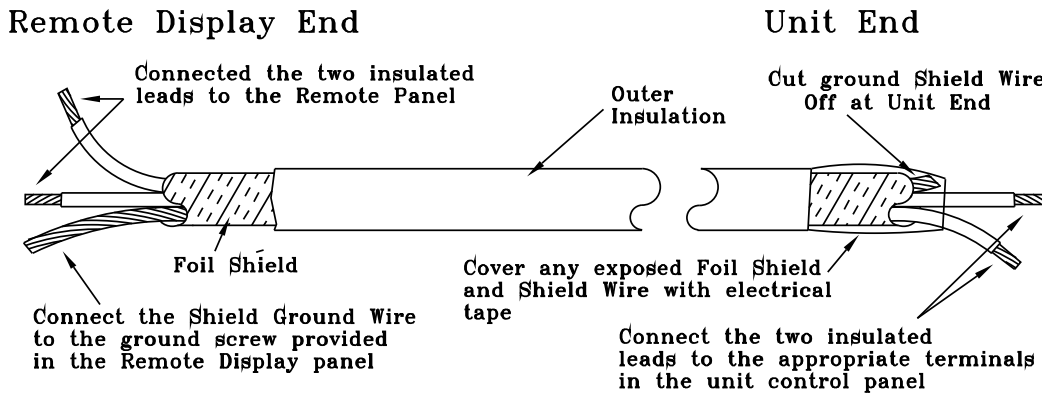

Interprocessor Communication Bridge Module Wiring

Refer to Figure 33, p. 49 and trim the outer covering of the shielded cable back approximately one inch. Cut the bare shield wire off even with the outer covering. Strip approximately 1/2-inch of insulation from each insulated wire in order to connect them to the terminal strip at the unit. Wrap tape around any exposed foil shield and/or base shield wire.

Note: The communication link is polarity sensitive.

Refer to the unit wiring diagram and connect the white lead to the positive (+) terminal and the black lead to the negative (-) terminal. (These terminals are numbered. Reference to color is for clarification to maintain polarity).

Note: To maintain polarity, do not connect the base shield wire to ground at the self-contained unit.

Note: Tape the non-insulated end of the shield on shielded wire at the unit. Any connection between the shield and ground will cause a malfunction. If daisy-chained in the unit, splice and tape the shields to prevent contact with ground.

Communication Wiring

Note: Communication link wiring is a shielded, twisted pair of wire and must comply with applicable electrical codes.

An optional communication link provides a serial communication interface (SCI) between Tracer Summit and each commercial self-contained (CSC) unit in the system. The CSC system can have a maximum of 12 CSC units per connection link to Tracer Summit. Use a single 18 AWG shielded, twisted pair wire with stranded, thinned copper conductors to establish each communication link between Tracer Summit and each unit.

Connecting to Tracer Summit

⚠ WARNING

Hazardous Voltage w/Capacitors!

Disconnect all electric power, including remote disconnects and discharge all motor start/run capacitors before servicing. Follow proper lockout/tagout procedures to ensure the power cannot be inadvertently energized. For variable frequency drives or other energy storing components provided by Trane or others, refer to the appropriate manufacturer's literature for allowable waiting periods for discharge of capacitors. Verify with an appropriate voltmeter that all capacitors have discharged. Failure to disconnect power and discharge capacitors before servicing could result in death or serious injury.

For additional information regarding the safe discharge of capacitors, see PROD-SVB06A-EN

IntelliPak™ commercial self-contained (CSC) units operate with Trane building automation software, Tracer Summit version 10.0.4 or later or any OS2 operating system.

Programming the Time Clock Option

Setting the Time

Important: Depress the reset key before beginning to set time and program.

1. Select military (24:00 hr.) or AM/PM (12:00 hr.) time mode by depressing and holding the "h" key while pressing "+ 1h" key to toggle between military and AM/PM. (AM appears in the display when in AM/PM mode.)
2. Press and hold down "⌚" key.
3. If setting the time when daylight savings time is in effect, press "+ 1h" key once (+ 1h will appear in display).
4. Set hour with "h" key. If AM or PM does not appear in display, the unit is in military time. See note above to change display.
5. Set minutes with "m" key.



Installation - Electrical

6. Press "Day" key repeatedly to the day of the week. (1 is Monday, 7 is Sunday)
7. Release "⌚" key, colon will begin flashing.

Note: If keys h + or m + are kept depressed for longer than 2 seconds, a rapid advance of figures will result.

The "Digi 20" electronic time switch is freely programmable for each day of the week in one minute increments. For easy and quick programming, the following 4 block programs are available:

- Monday through Sunday
- Monday through Saturday
- Monday through Friday
- Saturday and Sunday

Programming

Follow the instructions below for programming the time clock.

1. Press "Prog." key. 1234567 AM—:— will appear in display. (Pressing "Prog." key again, display will show the number of free programs "Fr 20"). Press again to RETURN to 1st program.
2. Press "👉" key, "⊙" ON symbol will appear. Pressing the key again will toggle to OFF "○". Select ON or OFF for the program.
3. Press "h+" to select hour for switching time.
4. Press "m+" to select minute for switching time.
5. If the program is to occur every day of the week, (24 hour time control) ignore "Day" key and press "Prog." key to advance to program.
6. For 7 day time control, press "Day" key. 1 2 3 4 5 6 (Monday through Saturday) block of days appears in display. Pressing "Day" key again, 1 2 3 4 5 (Monday through Friday) appears in display. Repeated presses will cycle through all days of the week and back to 1 through 7 (Monday through Sunday). Select day or block of days desired.
7. Press "Prog." key and repeat steps 2 through 6a to enter additional programs of ON and OFF times. (Note that more than one OFF time may be programmed, enabling automatic control or manual overrides.)
8. Press "⌚" key to enter run mode.

To review and change programs:

1. To review a program at any time, press "Prog." key. Programs display in the sequence they were entered with repeated presses of "Prog." key.
2. To change a program, select that program as outlined in step 1. Enter the time of day and days of week just as in the programming steps above. The old program is overwritten with the new selections. Press "Prog." to store the new program.
3. To delete an individual program, select the program as in step 1 and press "h" and "m" keys until "—:—"

appears in the display. Press either "Prog." or "1" key until "—:—" flashes. The program is deleted after a few seconds.

Manual Override

While in the "run" mode ("⌚" symbol is displayed), pressing the "👉" key will reverse the load status (switch load off if it is on, or switch it on if it is off). A hand symbol appears in the display to indicate the override is active. At the next scheduled switching time, automatic time control resumes, eliminating the override.

Pressing the "👉" key a second time "⊙" appears in the display indicating the load is permanently on.

Pressing the "👉" key a third time "○" appears in the display indicating the load is permanently off.

Pressing the "👉" key a fourth time returns to automatic, "👉" appears in the display.

All days shown in the respective blocks will switch on (or off) at the selected hour and minute.

Operating

Control Sequences of Operation

Occupied/Unoccupied Switching

There are four ways to switch occupied/unoccupied:

1. Night setback zone sensor
2. Field-supplied contact closure (hard wired binary input to RTM)
3. Tracer Summit
4. Factory-mounted time clock

Field Supplied Occupied/Unoccupied Input on the RTM

This input accepts a field supplied switch or contacts closure, such as a time clock, with a rating of 12 mA at 24 VDC minimum.

Tracer Summit System

The Tracer Summit system can control the occupied/unoccupied status of the self-contained unit.

Factory Mounted Time Clock

A time clock can control the occupied/unoccupied status of the self-contained unit.

Unoccupied Sequence of Operation

The unoccupied mode helps conserve energy during times when a building is usually unoccupied. When in unoccupied mode, the unit will control to the unoccupied setpoints (usually a lower heating setpoint and higher cooling setpoint). Setpoints can be programmed at the HI, Tracer Summit, or the night setback zone sensor.

The unit enters the unoccupied mode when the RTM receives a closed signal on the unoccupied input for more than five seconds. For units with supply air temperature control entering unoccupied mode, the following sequence will occur:

- Heating/cooling functions cease and the economizer option closes fully. The supply fan shuts down for proper cool-down time of the heat exchanger. However, the supply fan may remain on for a short period of time.
- After the supply fan shuts down, the occupied/unoccupied relay energizes, and the VAV box stroke time begins. The VAV box stroke time is field adjustable to allow time for VAV boxes to go to the full open airflow position.
- After the max VAV box stroke time expires, the supply fan, economizer (if enabled), compressors, and heat are enabled to satisfy the unoccupied zone temperature setpoints.

Note: Note: Unoccupied economizer operation can be enabled or disabled at the HI or using Tracer Summit.

Figure 34. Typical cycling morning warmup cycle

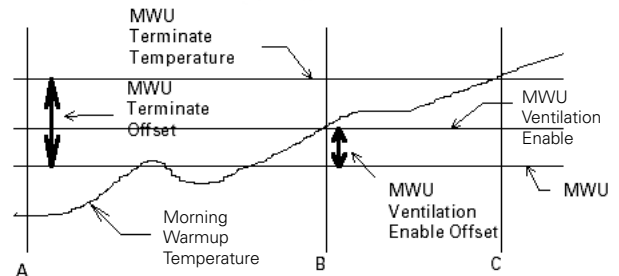

For units without volume control entering unoccupied mode, the following sequence will occur:

- The occupied/unoccupied relay energizes and the economizer option fully closes.
- The fan mode is set to auto and the unit will control to the unoccupied zone temperature setpoints.

With MWU enabled at the HI, if the zone temperature is below the MWU setpoint, the unit enters the MWU mode.

Morning Warm-up

This feature can be enabled at the HI, and can be used with factory or field-installed heat. If MWU is not required disable the function in the setup menu at the HI. MWU transitions the zone from unoccupied to occupied. It will heat until the MWU setpoint is met. The unit is then released to occupied mode. Supply duct static pressure is maintained during this sequence. MWU can be set (at the HI) to function as either full or cycling capacity.

Full Capacity Morning Warm-up (MWU)

Full capacity morning warm-up uses full heating capacity to heat the zone as quickly as possible. Full heating capacity is provided until the morning warm-up setpoint is met. At this point, the unit is released to daytime mode.

Cycling Capacity Morning Warm-up (MWU)

Cycling capacity morning warm-up provides a more gradual heating to overcome "building sink" as the zone is heated. Normal zone temperature control with varying capacity is used to raise the zone temperature to the MWU zone temperature setpoint. This method of warm-up is used to overcome the "building sink" effect.

Reference [Figure 34, p. 51](#) for a pictorial explanation of the cycling MWU sequence. Cycling capacity MWU will heat until MWU temperature setpoint is reached. Next a 60 minute timer begins. If the building load reaches the MWU ventilation setpoint, or the 60 minutes expire, whichever is first, the airside economizer will control to the minimum



Operating

position. MWU will end when the zone temperature rises above the MWU terminate setpoint.

Timed Override Activation - ICS™

This function is operational whenever the unit's RTM module is used as the zone temperature sensor source, which can be set at the HI panel. When this function is initiated by the push of the override button on the zone sensor, the unit will switch to the occupied mode. Unit operation (occupied mode) during timed override is terminated by a signal from Tracer.

Timed Override Activation - Non-ICS

This function is active whenever the unit's RTM module board is selected as the zone temperature source, which can be set at the human interface panel. When this function is initiated by the push of the override button on the zone sensor, the unit will switch to the occupied mode. Automatic cancellation of the timed override mode occurs after three hours of operation.

VAV Drive Max Output

This is a single-pole, double-throw relay rated at a maximum voltage of 24 vac, two amps max. The relay contacts of this relay switch when the unit goes from the occupied mode to the unoccupied mode by means of the unoccupied binary input, night setback zone sensor, or Tracer Summit. The contacts will stay switched during the unoccupied and morning warm-up mode. They will return to the position shown on the unit wiring diagram when the unit returns to the occupied mode. The intent of this binary output is to signal the VAV boxes or other terminal devices to go to a full open airflow position.

Occupied Sequence

All setpoints can be adjusted using the HI panel. Also, cooling/heating setpoints can be adjusted in the zone, if using one of the zone sensor options (BAYSENS020, BAYSENS021, BAYSENS108, BAYSENS110, BAYSENS019, or BAYSENS074). For a complete list of unit setpoint default values and ranges, see the *IntelliPak™ Self-Contained Programming Guide, PKG-SVP01B-EN*.

Occupied Zone Temperature - Cooling

The unit transitions from unoccupied to occupied when the occupied/unoccupied input on the RTM is open for more than five seconds after having been closed. This input can be received from Tracer Summit, the remote NSB zone sensor, the timed override function, or a field supplied contact. Dependent on unit options and the HI programming, the following sequence will occur:

- The unit will begin MWU and then switch to the occupied mode after the MWU setpoint is met.
- Purge will be enabled by Tracer Summit. Then Tracer Summit will enable the occupied mode.
- The unit will switch from unoccupied to occupied control immediately.

Upon entering occupied mode, the occupied/unoccupied relay will de-energize.

Zone Temperature Control (Unit Model Number Digit 9 = 4 or 5)

A zone sensor located directly in the space sends input to the RTM while the CV unit is in occupied cooling mode. When the unit is in occupied cooling, the RTM controls the zone temperature within the cooling setpoint deadband by modulating the economizer option and/or staging mechanical cooling on and off as required.

Supply Air Temperature Control (Unit Model Number Digit 9 = 1, 2, 3, or 6)

When the VAV unit is in occupied cooling, the RTM controls the supply air temperature to the specified supply air cooling setpoint by modulating the economizer option and/or staging mechanical cooling on and off as required. The changeover relay contacts (field supplied) must be open on units with hydronic heat for cooling to operate.

Cooling

Upon entering occupied mode, the RTM receives an input from either the HI, RHI, Tracer Summit, or the GBAS to start the supply fan. The RTM supply fan contacts close and energize the supply fan contactor. When the supply fan starts, the fan proving switch closes, signaling the RTM that airflow is established. The VFD will ramp the fan, and/or the airside economizer dampers will open to the user-defined minimum position.

When a cooling request is sent to the RTM from the zone sensor, the RTM evaluates the system operating conditions using the supply air and outdoor temperature input before sending the request to the MCM for mechanical cooling. If outdoor conditions (temperature and humidity) are suitable or the EWT is within specified setpoints, the RTM will attempt to use "free cooling" without using any compressors. The RTM will use either the airside or waterside economizer option. When outdoor air conditions are not suitable, only mechanical cooling will function and outside air dampers will remain at their minimum position. If the unit does not have an economizer, mechanical cooling will operate to satisfy cooling requirements.

Units With Economizer

If the entering condenser water temperature (units with a WSE) or the outside air enthalpy (units with an ASE) is appropriate to use "free cooling," the economizer will attempt to satisfy the cooling zone temperature setpoint.

Note: *When using an ASE with economizer enabled, O/A temperature enable can be used instead of comparative enthalpy if the O/A temperature falls below the economizer setpoint.*

Then compressors will stage on as necessary to maintain supply air temperature setpoint, which is user-defined at the HI. Minimum on/off timing of compressors prevents rapid cycling.

When both airside and waterside economizers are on a single unit, priority must be set at the HI. The economizer with the highest priority attempts cooling first. Once it is operating at its maximum, and if additional cooling is necessary, the other economizer enables before mechanical cooling begins.

Cooling/Waterside Economizer

Waterside economizing enables when the unit's entering water temperature is below the unit's entering mixed air temperature by 4°F plus the user adjustable economizer approach temperature. The approach temperature default is 4°F.

Waterside economizing disables when the unit's entering water temperature is not below the unit's entering mixed air temperature by at least the water economizer approach temperature (default value of 4°F). The economizer acts as the first stage of cooling. If the economizer is unable to maintain the zone (CV units) or supply air (VAV units) temperature setpoint, the compressor module will bring on compressors as required to meet the setpoint.

Cooling/Airside Economizer

On units with an airside economizer, a call for cooling will modulate the fresh air dampers open. The rate of economizer modulation is based on deviation of the zone temperature from setpoint; i.e., the further away from setpoint, the faster the fresh air damper will open. The first stage of cooling will start after the economizer reaches full open.

Note: *The airside economizer will only function freely if ambient conditions are below the enthalpy control settings or below the return air enthalpy if unit has comparative enthalpy installed. If outside air is not suitable for "economizing," the fresh air dampers drive to the minimum open position. A field adjustable, factory default setting at the HI panel or Tracer Summit can provide the input to establish the minimum damper position.*

When outdoor air conditions are above the setpoint or comparative enthalpy control setting, only mechanical cooling will function and outside air dampers will remain at their minimum position.

Mechanical Cooling

If the zone temperature cannot be maintained within the setpoint deadband using the economizer option or if there is no economizer, the RTM sends a cooling request to the MCM. The compressor module checks the compressor protection circuit before closing stage one. After the first functional stage starts, the compressor module monitors the saturated refrigerant temperature and closes the condenser fan output contact when the saturated refrigerant temperature rises above the lower limit setpoint.

Air-Cooled Units Only

The compressor module closes the condenser fan output contact when the saturated refrigerant temperature rises above the lower limit setpoint.

Water-Cooled Units Only

The WSM modulates the condenser coil water valves to maintain condenser temperature, if applicable. Otherwise, it will check the entering condenser water temperature to ensure it is greater than 54°F or if not, it will lock out cooling.

Auto Changeover (Units with Heat Only)

When the system mode is in auto, the mode will change to cooling or heating as necessary to satisfy the zone cooling and heating setpoints. The zone cooling and heating setpoints can be as close as 2°F (1.1°C).

Occupied Zone Temperature - Heating

Relies on input from a sensor directly in the space, while a system is in occupied heating mode or an unoccupied period, to stage electric heat on and off or modulate the hydronic heating valve as required to maintain the zone temperature within the heating setpoint deadband. The supply fan will operate when there is a request for heat.

Electric Heat

On units with electric heat, the zone temperature can be controlled to a heating setpoint during the occupied mode by cycling a single stage electric heater. An interface is provided for field supplied single stage electric heat. The zone temperature heating setpoint and deadband are user defined at the HI panel.

Hydronic Heat: Hot Water or Steam

On units with hot water or steam heating, the zone temperature can be controlled to a heating setpoint during the occupied mode. The zone temperature heating setpoint and deadband are user defined at the HI panel or zone sensor. VAV occupied heating initiates by closing a field-supplied switch or relay contacts connected to the changeover input on the RTM. Supply air static pressure is maintained.

Supply Air Setpoint Reset (VAV Units Only)

Supply air reset can be used to adjust the supply air temperature setpoint on the basis of a zone temperature or outdoor air temperature. Supply air reset adjustment is available at the HI panel for supply air heating and supply air cooling control.

Reset based on outdoor air temperature

Outdoor air cooling reset is sometimes used in applications where the outdoor temperature has a large effect on building load. When the outside air temperature is low and the building cooling load is low, the supply air setpoint can be raised, thereby preventing subcooling of critical zones. This reset can lower usage of mechanical



Operating

cooling, thus savings in compressor kW, but an increase in supply fan kW may occur.

Outdoor air heating reset is the inverse of cooling, with the same principles applied.

For both outdoor air cooling reset and heating reset, there are three user defined parameters that are adjustable through the human interface panel.

- Beginning reset temperature
- Ending reset temperature
- Maximum amount of temperature reset

Reset based on zone temperature

Zone reset is applied to the zone(s) in a building that tends to overcool or overheat. The supply air temperature setpoint is adjusted based on the temperature of the critical zone(s). This can have the effect of improving comfort and/or lowering energy usage. The user-defined parameters are the same as for outdoor air reset.

Supply Air Tempering (Hot Water and Steam VAV Units Only)

When supply air temperature falls below the supply air temperature deadband low end, the heating valve modulates open to maintain the minimum supply air temperature setpoint.

Daytime Warm-up (Units with Supply Air Temperature Control Only)

During occupied mode, if the zone temperature falls to a preset, user-defined zone low limit temperature setpoint, the unit is put into daytime warm-up. The system changes over to CV heating, the VAV boxes drive full open. However, unit airflow modulation control operates to maintain duct static setpoint, and full heating capacity is provided until the daytime warm-up setpoint is reached. The unit is then returned to normal occupied mode.

Supply Air Tempering

Supply air tempering is available on units without volume control and with hot water, steam, or electric heat or units with supply air temperature control with steam or electric heat. When the unit is in heat mode but not actively heating, if the supply air temperature drops to 10°F (5.5°C) below the occupied zone heating temperature setpoint, electric heat will stage on or the hydronic valve will modulate to maintain a minimum supply air temperature. The unit transitions out of heat mode if the supply air temperature rises to 10°F (5.5°C) above the occupied zone heating temperature setpoint.

Changeover

This mode only functions on units with supply air temperature control with hydronic heat. When the changeover binary input is closed the unit will control to a discharge air heating setpoint. This setpoint is entered from the HI, and can be a higher temperature than the

supply air cooling setpoint. This function maintains duct static pressure.

Thermostatic Expansion Valve

NOTICE:

Compressor Damage!

Systems operating with lower superheat than recommended could cause serious damage to the compressor.

Refrigerant system reliability and performance is heavily dependent upon proper superheat. The importance of maintaining the proper superheat cannot be overemphasized. Accurate measurements of superheat will provide the following information:

- How well the expansion valve is controlling the refrigerant flow.
- The efficiency of the evaporator coil.
- The amount of protection the compressor is receiving against flooding.

The expected range for superheat is 14-20°F at full load conditions. At part load, expect a properly adjusted expansion valve to control to 8-12°F superheat. Systems operating with lower superheat could cause serious compressor damage due to refrigerant floodback.

Compressors

Units use two sizes of hermetic scroll compressors, 10 and 15 hp, and have from two to six compressors. When viewing the front of the unit, compressors are identified A through F from left to right. The second compressor from the left, or B compressor, is always the first to come on, unless locked out for a malfunction or shut off on frost protection. See [Table 35, p. 55](#) for compressor cycling stages and [Table 1, p. 11](#) and [Table 2, p. 12](#) for percent cooling capacity by stage.

R-410 compressors have belly band heaters that must be energized 24 hours before starting compressor. Power to the unit will energize the heaters. Heaters will be energized during the off-cycle as long as the unit has power. Failure to perform these pre-start instructions could result in compressor damage.

The control system logic permits compressor operation only after the supply fan is on. If the supply fan shuts down, compressors will not operate. Units without head pressure control (units with intermediate piping packages) will lock out mechanical cooling when the entering condenser water temperature falls below 54°F. Mechanical cooling will resume when the entering condenser water temperature exceeds 58°F.

When there are more than two compressors in an air cooled unit, the first two compressors are manifolded together. If there are four compressors, the second two are manifolded.

Compressor Cycling

Compressors cycle to maintain the operating state required by the temperature controls. In the event of a compressor failure, the next available compressor turns on. Refer to [Table 35, p. 55](#) for compressor cycling by unit model and tons.

During normal conditions, compressors will not shut off until they have been on for at least three minutes and will not turn on until they have been off for at least three minutes. Normal operating conditions are established on an individual compressor basis. When a compressor starts, its timer also starts. The compressor evaporator circuit frost protection can override the “minimum” timer and reduce the five minute minimum required time period.

When the unit is powered up, or manually reset there will be a three to eight minute delay before the first compressor may be turned on as requested by the unit temperature control algorithm.

Compressor Lead/Lag Operation

Compressor lead/lag is a user-selectable feature at the HI panel and is available on all units. After each request for compressor operation, the lead refrigeration circuit or compressor switches, thereby causing a more equitable or balanced run time among compressors.

When lead/lag is enabled, each time the system cycles, it will alternate between the standard compressor staging and the lead/lag staging. Using [Table 35, p. 55](#), a SXWF 29-ton unit will first stage compressor B then A, then AB for first cycle and A, then AB for the second cycle. Appropriate condenser valves (water-cooled and condenser fans (air-cooled) will stage with appropriate compressors to maintain saturated condensing temperature. Enabling lead/lag may drop a cooling stage when compared to standard staging. See [Table 35, p. 55](#) for compressor staging.

Step Control

Steps of mechanical cooling are control based on supply air or zone temperature. See [Table 35, p. 55](#) for compressor staging.

Table 35. Compressor stage

Unit size	Refrigerant circuit type	Compressor by stage						Compressor staging	Compressor staging
		A	B	C	D	E	F		
SXWF 20, 22, 25 SXRF 20	Independent	10	10					B/AB	A/AB
SXWF 29, 32 SXRF 25, 29	Independent	15	10					B/A/AB	A/AB
SXWF 35, 38	Independent	10	10	10				B/BC/ABC	A/AC/ABC
SXRF 30, 35	Manifolded	10	10	10				B/BC/ABC	A/AC/ABC
SXWF 42, 46	Independent	15	10	10				B/A/AC/ABC	C/AC/ABC
SXRF 40	Manifolded	15	10	10				B/A/AC/ABC	C/AC/ABC
SXWF 52, 58	Independent	15	15	15				B/BC/ABC	A/AC/ABC
SXRF 50	Manifolded	15	15	15				B/BC/ABC	A/AC/ABC

Capacity is based on an integrating control concept. The unit capacity matches the existing load and maintains an average supply air temperature within the supply air setpoint temperature control band region.

The supply air temperature control band is centered around supply air temperature setpoint and is adjustable from 2 to 12°F. In a steady state, the unit will either maintain a constant level of cooling capacity with the supply air temperature within the control band, or the highest active cooling level will cycle to provide an average supply air temperature equal to the setpoint.

If the supply air temperature swings outside the limits of the control band, the mechanical cooling capacity will increase or decrease by one level accordingly. The change occurs by integrating the temperature offset from the control band limit.

A minimum time delay of five minutes follows each change in cooling level. This time delay promotes stability by allowing the system to respond to the change before any further control action occurs. As the supply air temperature approaches setpoint, the time duration between changing levels of cooling capacity increases.

See [Figure 35, p. 56](#) for the typical unit operating curve. [Figure 36, p. 56](#) shows typical unit performance when supply air temperature swings exceed the control band limits.

Adjust the supply air temperature control band according to the desired unit performance. Increasing the control band reduces the equipment cycle rate and increases the maximum potential supply air temperature deviation from setpoint. Conversely, decreasing the control band reduces the maximum potential temperature deviation, but increases the compressor cycle rate.

Follow these recommendations concerning the supply air temperature control band settings based on expected unit sizing:

- 2 Cooling stage unit: 9°F
- 3 Cooling stage unit: 7°F
- 4 Cooling stage unit: 6°F

Table 35. Compressor stage (continued)

Unit size	Refrigerant circuit type	Compressor by stage						Compressor staging	Compressor staging
		A	B	C	D	E	F		
SXWF 65, 72	Independent	15	15	15	10			B/BD/ABD/ABCD	A/AD/ACD/ABCD
SXWF 80	Independent	15	15	15	15			B/BD/ABD/ABCD	A/AC/ABC/ABCD
SXRF 60	Manifolded	15	15	15	15			B/BD/ABD/ABCD	A/AC/ABC/ABCD
SCWF 90	Independent	15	15	15	15	15		A/AB/ABC/ABCDE	C/CDE/ACDE/BCDEF
SCWF 100	Independent	15	15	15	15	10	10	A/AB/ABCD/ABCDEF	CD/CDEF/ACDEF/ABCDEF
SCWF C1	Independent	15	15	15	15	15	15	A/AB/ABCD/ABCDEF	CD/CDEF/ACDEF/ABCDEF

Figure 35. Typical pulldown curve for unit operating properly within control band

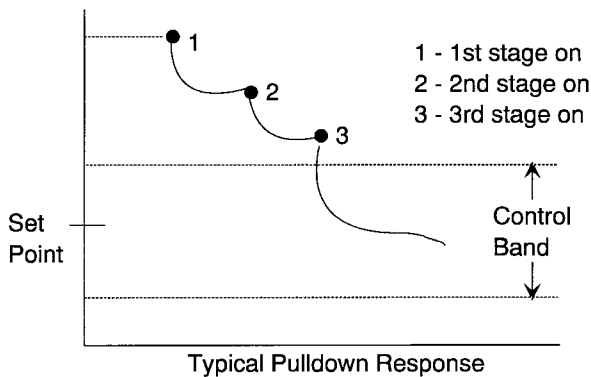
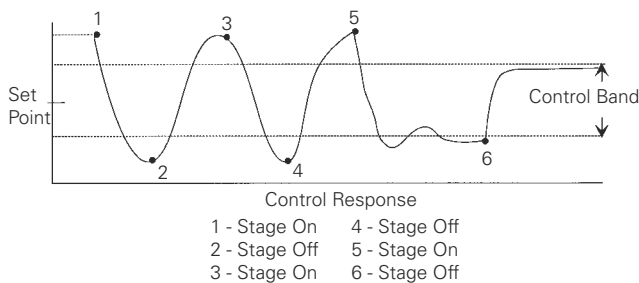

Figure 36. Typical pulldown curve for unit operating improperly outside control band



Compressor Safety Devices

If a compressor low pressure cutout opens during compressor start-up, the UCM will not shut the compressor off during the first two to three minutes after start-up. This prevents possible nuisance trips during low ambient start conditions. See [Table 36, p. 56](#).

Each compressor's discharge line contains a high pressure cutout. Under abnormal operating conditions, the cutout will open to stop compressor operation.

Table 36. Pressure cutouts (open/close)

Unit Model	High Pressure Cutout	Low Pressure Cutout
SXWF	553/424	49/74
SXRF	650/500	36/61

Low Ambient Compressor Lockout

This function will lock out the compressor if the outdoor air temperature sensor reads an outdoor temperature below the low ambient compressor lockout temperature setpoint. This setpoint is adjustable at the human interface panel. Compressors will lock out when outdoor air temperature falls below that selected temperature and will start again when the temperature rises 5°F above the setpoint.

Evaporator Coil Frost Protection FROSTAT™

The FROSTAT™ system eliminates the need for hot gas bypass. It utilizes an evaporator temperature sensor mounted on the suction line near the TXV bulb of each circuit to protect the evaporator from freezing.

If the evaporator temperature approaches the specified setpoint (adjustable between 25 and 35°F at the HI) the compressor(s) will cycle off. The supply fan remains on to help de-ice the coil. The compressors will restart when the evaporator temperature has risen 10°F above the specified cutout temperature and when the compressor(s) have been off a minimum of three minutes. This prevents rapid cycling of the compressors.

Service Valve Option

If ordered, service valves are factory installed on each circuit before and after the compressor to allow compressor isolation for servicing.

Waterside Components

Waterside components consist of water piping, water valves, water flow switch option, water cooled condensers (SXWF only), and the economizer option.

Water Purge

NOTICE:

Proper Water Treatment!

The use of untreated or improperly treated water in coils could result in scaling, erosion, corrosion, algae or slime. It is recommended that the services of a qualified water treatment specialist be engaged to determine what water treatment, if any, is required. Trane assumes no responsibility for equipment failures which result from untreated or improperly treated water, or saline or brackish water.

This user-definable feature allows the user to select a purge schedule to automatically circulate water through the economizer and condensers periodically during non-operational times. This allows fresh chemicals to circulate in waterside heat exchangers. This feature is on all units and is defined at the HI.

Water Piping Options

Water piping is factory-installed with left-hand connections on units without a waterside economizer. Units can be ordered with either basic piping or intermediate piping. Also, units with waterside economizers can be set for either variable or constant water flow at the HI. See [Figure 37, p. 58](#) and [Figure 38, p. 58](#) for detailed piping configuration information.

With compatible piping configurations, the unit can be configured to provide:

1. Constant water flow with basic or intermediate piping or
2. Variable water flow (head pressure control) with intermediate piping only.

Constant water flow is for condenser pumping systems that are not capable of unloading the water-pumping system. Variable water flow maximizes energy saving by unloading the water pumping system.

Basic Water Piping

This option is available on units without a waterside economizer and with condenser water applications above 54°F (12.2°C) that do not require condensing pressure control. Left hand water connections and piping are extended to the unit exterior. Manifold piping is factory installed.

Intermediate Water Piping

This option provides condensing temperature control when the unit is configured (user defined at the HI) for variable water flow with or without a waterside economizer. A two-way modulating control valve is wired and installed in the unit to maintain a specific range of water temperature rise through the condenser when entering fluid temperature is less than 58°F (15°C). This option allows the compressor to operate with entering fluid temperature down to 35°F (2°C). The minimum valve

position to maintain minimum condenser flow rates is user-defined at the HI. This valve drives closed if the unit shuts down or if a power failure occurs.

Water Flow Switch Option

A water flow switch is factory installed in the condenser water pipe within the unit. Whenever the flow switch detects a water flow loss prior to or during mechanical cooling, compressor operation locks out and a diagnostic code displays. If water flow is restored, the compressor operation automatically restores.

Water-Cooled Condensers

Units that are set up for variable water flow will modulate a water valve to maintain a user-defined condensing temperature setpoint. Condensing temperature will be referenced utilizing factory installed sensors located at each condenser.

Table 37. Condenser water piping connection sizes

Unit size	Inlet pipe	Outlet pipe
SXWF 20, 22, 25, 29, 32, 35, 38	2 1/2 NPT	2 1/2 NPT
SXWF 42, 46, 52, 58, 65, 72, 80, 90, 100, 110	3 NPT	3 NPT

Waterside Economizer Option

The waterside economizer option takes advantage of cooling tower water to either precool the entering air to aid the mechanical cooling process or, if the water temperature is low enough, provide total system cooling. Waterside economizing enables when the unit's entering water temperature is below the unit's entering mixed air temperature by a minimum of 4°F plus the economizer's approach temperature. The approach temperature default is 4°F. Waterside economizing disables when the unit's entering water temperature is not below the unit's entering mixed air temperature by at least the water economizer approach temperature. The approach temperature defaults to 4°F. The economizer acts as the first stage of cooling. If the economizer is unable to maintain the supply air setpoint, the unit control module brings on compressors as required to meet the setpoint.

The waterside economizer includes a coil, modulating valves, controls, and piping with cleanouts. The coil construction is 1/2-inch (13 mm) OD seamless copper tubes expanded into aluminum fins. The evaporator and economizer coils share a common sloped (IAQ) drain pan. Drain pan options are either galvanized or stainless steel, and are insulated and internally trapped.

The waterside economizer coil is available with either a two or four row coil, with no more than 12 fins per inch. The tubes are arranged in a staggered pattern to maximize heat transfer. The coil has round copper supply and return headers with removable cleanout and vent plugs. The optional mechanical cleanable economizer has removable cast iron headers to allow easy mechanical cleaning of the tubes. The waterside working pressure is rated for 400 psig (2758 kPa).

Waterside Economizer Flow Control

Units equipped with a waterside economizer can be set from the human interface panel for variable or constant water flow.

Constant Water Flow

Two-way modulating control shutoff valves are wired, controlled, and installed in unit. One valve is located in economizer's water inlet, and the other in condenser bypass water inlet. When waterside economizer enables, two-way valves modulate to maintain discharge air temperature setpoint. As economizer valve opens, condenser bypass valve closes, and vice versa. Full water flow is always maintained through condensers. Both valves will close in event of a power failure.

Variable Water Flow

Two-way modulating control shutoff valves are wired, controlled, and installed in the unit. One valve is located in the economizer's water inlet, and the other is in the condenser water inlet. When the economizer valve is active, the condenser bypass valve closes. The economizer valve modulates, thus water flow through the unit modulates. If the water is cool enough for economizing, but mechanical cooling is also required, the economizer valve fully opens to establish full water flow through the condensers. Whenever the water is too warm for economizing and there is a call for cooling, the economizer valve fully closes and the bypass valve fully

opens, establishing full water flow through the condensers. Full water flow is always maintained through the condensers when mechanical cooling is required. Both valves close whenever cooling is not required, and in the event of a power failure.

Figure 37. Basic water piping, constant water flow

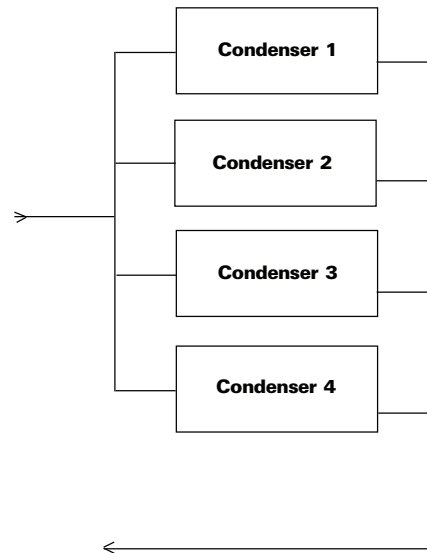
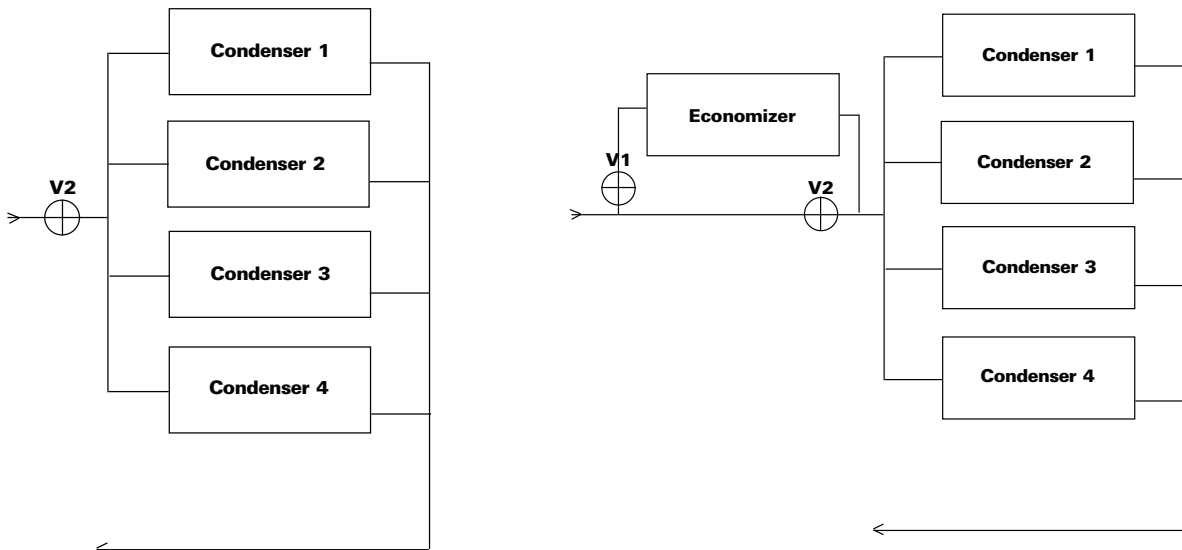

Figure 38. Intermediate water piping, variable water flow (L) and Intermediate piping with waterside economizer, variable or constant water flow (R)



Unit Airside Components

The unit's air delivery system consists of dampers, enthalpy switch option, airside economizer option, filters, low ambient sensors, and factory mounted single or double wall plenums.

Supply Air Fan

The unit has a single supply fan that runs at a constant speed. However, the fan may have the VFD option that modulates airflow based on supply air temperature control. Pressing the stop key on the HI will turn the supply fan off. The fan is on continuously when a CV unit is in

occupied mode and except when a unit is in the night heat/morning warm-up mode. During the night heat and setback mode the fan cycles on and off in response to a call for heat. See [Table 38, p. 59](#) for available fan horsepower.

Table 38. Supply fan horsepower selections

Unit Model		HP									
SXRF	SXWF	5	7.5	10	15	20	25	30	40	50	60
20	20, 22, 25	X	X	X	X	X					
25, 29	29, 32	X	X	X	X	X					
30, 35	35, 38	X	X	X	X	X	X				
40	42, 46		X	X	X	X	X	X			
50	52, 58, 65			X	X	X	X	X	X		
60	72, 80			X	X	X	X	X	X	X	
	90, 100, 110				X	X	X	X	X	X	X

Low Entering Air Temperature Sensor

This is standard on all units with a hydronic coil or waterside economizer. It can also be ordered as an option.

A thermostat limit switch is factory mounted on the unit's entering air side with a capillary tube serpentine across the coil face. If the temperature falls below 35°F (2°C), the fan shuts down and the waterside economizer and/or hydronic heat valve options open to allow full water flow. The heat output also energizes. A manual reset is required. The low entering air temperature setpoint is adjustable at the HI.

High Duct Temperature Thermostat

A factory-supplied temperature limit switch with reset element detects the supply air duct temperature. This sensor should be field-installed downstream from the unit's discharge in the supply air duct. If the supply air duct temperature exceeds 240°F (115.6°C), the unit shuts down and displays a diagnostic. A manual reset is required at the unit. High duct temperature can be adjusted at thermostat.

Dirty Filter Sensor Option

A factory installed pressure switch senses the pressure differential across the filters. When the differential pressure exceeds 0.9-inches (23 mm)WG, contact closure occurs and the HI will display a diagnostic. The unit will continue to run until you replace the air filters.

A field installed indicator device may be wired to relay terminals to indicate when filter service is required. Contacts are rated at 115 VAC and are powered by a field supplied transformer.

Low Ambient Sensor (Air-Cooled Units)

Low ambient sensor is field-installed on air-cooled units. Position it in a location subject to ambient temperatures only and not exposed to direct sunlight or exhaust fans.

The low pressure cutout initiates based on the ambient temperature. A time delay on the low pressure cutout

initiates for ambient temperatures between 50 (zero minutes) and 0°F (10 minutes). This helps to prevent nuisance low pressure cutout trips.

Supply Air Static Pressure Limit

The opening of the VAV boxes coordinate during unit startup and transition to/from occupied/unoccupied modes to prevent supply air duct over pressurization. However, if for any reason the supply air pressure exceeds the user-defined supply air static pressure limit set at the HI panel, the supply fan VFD shuts down. The unit will attempt to restart, up to three times. If the over pressurization condition still occurs on the third restart, the unit shuts down and a manual reset diagnostic sets and displays at the HI.

Variable Frequency Drive Option

Variable frequency drive (VFD) is driven by a modulating 0-10 vdc signal from the RTM module. A pressure transducer measures duct static pressure, and the VFD adjusts fan speed to maintain the supply air static pressure within an adjustable user-defined range. The range is determined by the supply air pressure setpoint and supply air pressure deadband, which are set at the HI panel.

VFDs provide supply fan motor speed modulation. The drives will accelerate or decelerate as required to maintain the supply air static pressure setpoint.

VFD with Bypass

Bypass control is an option that provides full nominal airflow in the event of drive failure. The user must initiate the bypass mode at the HI panel. When in bypass mode, VAV boxes need to be fully open. The self-contained unit will control heating and cooling functions to maintain setpoint from a user-defined zone sensor. Supply air static pressure limit is active in this mode.

For more detailed information on VFD operation, reference VFD technical manual that ships with the unit.

Airside Economizer Option

Units with the airside economizer option are equipped with the necessary control sequences to use outside air for the first stage of cooling, in occupied or unoccupied mode and when ambient conditions are favorable for economizing. Inherent in the unit controller is the ability to suppress the setpoint below the normal unit setpoint. This allows the building to improve comfort levels when possible, and at the same time, optimize building mechanical cooling operation for peak operating efficiency. An outside air temperature and relative humidity sensor are provided to allow monitoring of reference enthalpy and are field installed.

If the unit has the ECEM board, economizer operation enables when the outside air enthalpy is less than 25 BTU's/lb. default (adjustable 19-28 BTU's/lb). During occupied mode, the outside air damper opens to 15% (adjustable 0-100% at the HI) for ventilation purposes. Also, the ability to alter the outside air damper position to

Operating

compensate for VAV supply air modulation is inherent in the unit controls, and can be enabled by the operator.

If the unit does not have an ECEM board, it will economize when the O/A temperature falls below the O/A economizer setpoint.

The mixing box fabrication is galvanized steel. Opposed low leak damper blades are fabricated from galvanized steel and rotate on rustproof nylon bushings. A factory installed 24V modulating spring return actuator controls both damper positions.

When outdoor conditions are not suitable for economizer cooling, the enthalpy control disables the economizer function and permits the outdoor air damper to open only to the minimum position.

On water-cooled units, compressor operation lockout will not occur at low ambient air temperatures. However, lockout will still occur via low condenser water temperature.

The outdoor air dampers drive fully closed whenever the supply air fan is off, provided there is power to the unit.

Comparative Enthalpy Control

Comparative enthalpy controls the economizer operation and measures temperature and humidity of both return air and outside air to determine which source has lower enthalpy. This allows true comparison of outdoor air and return air enthalpy by measurement of outdoor air and return air temperatures and humidities. A factory-installed control board, with field-installed outside and return air temperature and relative humidity sensors, allows monitoring of outside and return air.

Note: *If comparative enthalpy is not ordered, standard method is to compare outdoor air enthalpy with the fixed reference enthalpy. The reference enthalpy is set through the human interface panel.*

Units with comparative enthalpy control are equipped with the necessary control sequences to allow using outside air for the first stage of cooling, in occupied or unoccupied mode and when ambient conditions are favorable for economizing. Inherent in the unit controller is the ability to suppress the setpoint below the normal unit setpoint. This allows building to improve comfort levels when possible, and at the same time, optimize building mechanical cooling operation for peak efficiency.

Economizer operation enables when the outside air enthalpy is 3 BTU/lb less than the return air enthalpy. During occupied mode, the outside air damper opens to 15% (adjustable 0-100%) for ventilation purposes. Also, the ability to alter the outside air damper position to compensate for VAV supply air modulation is inherent in the unit controls, and can be enabled by the operator.

The mixing box fabrication is galvanized steel. Opposed low leak damper blades are fabricated from galvanized steel and rotate on rustproof nylon bushings. A factory installed 24V modulating spring return actuator controls both damper positions.

Airside Economizers with Traq™ Damper

Outside air enters the unit through the Traq™ damper assembly and is measured by velocity pressure flow rings. The velocity pressure flow rings are connected to a pressure transducer/solenoid assembly, which compensates for temperature swings that could affect the transducer. The ventilation control module (VCM) utilizes the velocity pressure input, the RTM outdoor air temperature input, and the minimum outside air cfm setpoint to modify the volume (cfm) of fresh air entering the unit as the measured airflow deviates from setpoint.

When the optional preheat temperature sensor is installed at the auxiliary temperature on the VCM and the preheat function is enabled, the sensor will monitor the combined (averaged) fresh air and return air temperatures. As this mixed air temperature falls below the preheat actuate temperature setpoint, the VCM activates the preheat binary output to control a field-installed heater. The output deactivates when the temperature rises 5°F above the preheat actuate temperature setpoint.

Using a field-installed CO₂ sensor with CO₂ reset enabled, as the CO₂ concentration increases above the CO₂ reset start value, the VCM modifies the minimum outside air cfm setpoint to increase the amount of fresh air entering the unit. The setpoint adjusts upward until reaching the CO₂ maximum reset value. The maximum effective (reset) setpoint value for fresh air is limited to the system's operating cfm. As the CO₂ concentration decreases, the effective (reset) setpoint value adjusts downward toward the minimum outside air cfm setpoint. See [Figure 39, p. 60](#) for an airflow cfm vs. CO₂ concentration curve.

Figure 39. CO₂ reset function, outside air vs. CO₂

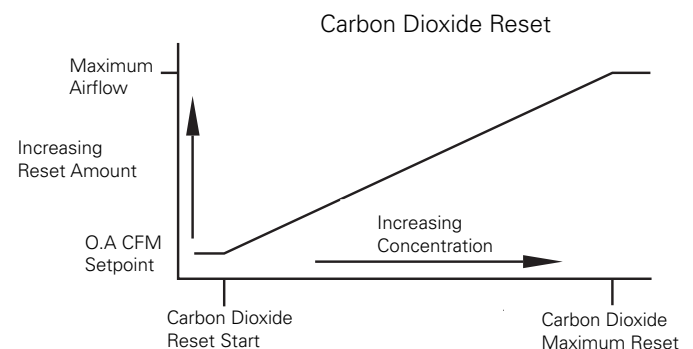

Standard Two-Position Damper Interface

Units with the two-position damper interface are provided with a 0-10 VDC control output suitable for controlling a field-provided modulating actuator. In occupied mode, the output drives to the maximum position.

Airside Economizer Interface

Units with airside economizer interface are equipped with the necessary control sequences to allow using outside air for first stage of cooling, in occupied or unoccupied mode

and when ambient conditions are favorable for economizing. Inherent in unit controller is the ability to suppress setpoint below normal unit setpoint. This allows the building to improve comfort levels when possible, and at the same time, optimize building mechanical cooling operation for peak operating efficiency. An outside air temperature and relative humidity sensor are provided for field installation to monitor reference enthalpy.

Economizer operation enables when the outside air enthalpy is less than 25 BTu/lb (adjustable 19-28 BTu/lb.). During occupied mode, the outside air damper opens to 15% (adjustable 0-100%) for ventilation purposes. Also, the ability to alter the outside air damper position to compensate for VAV supply air modulation is inherent in the unit controls, and can be enabled by the operator. An analog 2-10VDC output (adjustable 0-10VDC) is provided to modulate the field-provided 30 second damper actuators (adjustable 1-255 seconds).

Airside Economizer Interface with Comparative Enthalpy

Units with airside economizer interface and comparative enthalpy are equipped with the necessary control sequences to allow using outside air for the first stage of cooling, in occupied or unoccupied mode and when ambient conditions are favorable for economizing.

Inherent in the unit controller is the ability to suppress the setpoint below the normal unit setpoint. This allows the building to improve comfort levels when possible, and at the same time, optimize building mechanical cooling operation for peak operating efficiency. A factory-installed control board, with outside and return air temperature and relative humidity sensors, are provided for monitoring outside and return air. The sensors are field installed.

Economizer operation enables when the outside air enthalpy is 3 BTU's/lb. less than the return air enthalpy. During occupied mode, the outside air damper opens to 15% (adjustable 0-100%) for ventilation purposes. Also, the ability to alter the outside air damper position to compensate for VAV supply air modulation is inherent in the unit controls, and can be enabled by the operator. An analog 2-10VDC output (adjustable 0-10VDC) is provided to modulate the field-provided 30-second damper actuators (adjustable 1-255 seconds).

Air-Cooled Condensers

Model SXRF units are designed for use with the remote air-cooled condenser, model CXRC. For more information, see the air-cooled condenser Installation, Owner, and Maintenance Manual, *CXRC-SVX01*-EN*. See [Table 24, p. 34](#) for CXRC refrigerant connection sizes.

Condenser fans will stage per a user-defined setting. If the condenser is equipped with head pressure control (air modulation on last stage of condenser capacity), the condenser airflow will modulate to maintain condensing temperature setpoint. Condensing temperature is determined by sensors located at each condenser coil.



Controls

Points List

RTM Module

Binary Inputs

- Emergency stop
- External auto/stop
- Unoccupied/occupied
- Dirty filter
- VAV changeover with hydronic heat

Binary outputs

- VAV box drive max (VAV units only)
- CV unoccupied mode indicator (CV units only)
- Alarm
- Fan run request
- Water pump request (water-cooled only)

Analog input

- Airside economizer damper minimum position

Analog output

- Outside air damper actuator

Heat Module:

- Analog output

GBAS Module

Binary inputs

- Demand limit contacts

Binary outputs

- Dirty filter relay
- Refrigeration fail relay
- Heat fail relay
- Supply fan fail relay
- Active diagnostics

Analog inputs

- Occupied zone cooling setpoint
- Occupied zone heating setpoint
- Unoccupied zone cooling setpoint
- Unoccupied zone heating setpoint or minimum outside air flow setpoint
- Supply air cooling setpoint
- Supply air heating setpoint
- Supply air static pressure setpoint

ECEM Module

Analog inputs

- Return air temperature
- Return air humidity

In addition, units with a VOM have:

Binary inputs

- VOM mode A, unit off
- VOM mode B, pressurize
- VOM mode C, exhaust
- VOM mode D, purge
- VOM mode E, purge w/duct pressure control

Binary output

- V.O. relay

Tracer /LCI-I option

Constant Volume (CV)

Binary inputs

- Airside economizer enable/disable
- Condenser type (air or water cooled)
- Condenser water flow status
- Emergency shutdown
- Local fan switch enable/disable
- Mechanical cooling lockout
- Mechanical heating lockout
- Mixed air temperature
- Occupancy
- Occupancy override
- Occupancy sensor

Binary outputs

- Airside economizer status
- Alarm status
- Compressor on/off status
- Condenser circuit information
- Condenser water pump status
- Waterside economizer status

Analog inputs

- Airside economizer dry bulb setpoint
- Airside economizer minimum setpoint
- Building static pressure input
- Maintenance required time

- Occupancy bypass time
- Outdoor air damper minimum position setpoint
- Outdoor air relative humidity
- Outdoor air temperature
- Unit start delay time setpoint
- Zone temperature
- Zone temperature setpoint
- Zone temperature setpoint (default)
- Zone temperature setpoint limits
- Zone temperature setpoint offsets
- Zone temperature setpoint shift

Analog outputs

- Alarm message
- Building static pressure status
- Condenser saturated refrigerant temperature
- Condenser water temperature
- Cooling output status
- Effective occupancy
- Exhaust fan status
- Heating output status
- Heating/cooling mode
- Morning warm up sensor temperature
- Outdoor air damper position
- Outdoor air enthalpy
- Outdoor air relative humidity
- Return air temperature
- Supply air temperature
- Supply fan status
- Unit status mode
- Zone CO2
- Zone relative humidity

Variable Air Volume (VAV)

Binary Input

- Airside economizer enable/disable
- Condenser water flow input
- Emergency override
- Local fan switch enable/disable
- Mechanical cooling lockout
- Mechanical heating lockout
- Occupancy

Binary Outputs

- Airside economizer status
- Alarm status

- Compressor on/off status
- Condenser circuit information
- Condenser type (water or air cooled)
- Condenser waterflow status
- Condenser waterflow status
- Condenser water pump status

Analog Inputs

- Airside economizer dry bulb setpoint
- Airside economizer minimum position
- Building static pressure input
- Building static pressure setpoint
- Daytime warm up setpoint
- Daytime warm up terminate setpoint
- Maintenance required time
- Occupancy bypass time
- Outdoor air damper minimum position setpoint
- Outdoor airflow minimum setpoint
- Outdoor air relative humidity
- Outdoor air temperature
- Supply air cooling setpoint
- Supply air cooling setpoint (default)

Analog Outputs

- o Building static pressure status
- o Alarm message
- o Condenser saturated refrigerant temp.
- o Condenser water temperature
- o Condenser water temp (local)
- o Cooling output status
- o Exhaust fan status
- o Heating output status
- o Heating/cooling mode
- o Mixed air temperature
- Morning warm up sensor temperature
- Outdoor air damper position
- Outdoor air enthalpy
- Outdoor air flow
- Outdoor air relative humidity status
- Outdoor air temperature status
- Return air temperature

BCI-I option

For BACnet® Points List refer to ACC-SVP01*-EN

Phase Monitor

Unit is equipped with phase monitor in control box. The phase monitor will protect against phase loss, imbalance and reversal of line voltage. If a fault occurs, the red LED will energize. While the fault condition is present, the phase monitor interrupts the 115V control circuit. If no faults are observed, a green LED will be energized.

Unit Control Components

The Signature Series IntelliPak™ self-contained unit is controlled by a microelectronic control system that consists of a network of modules. These modules are referred to as unit control modules (UCM). In this manual, the acronym UCM refers to the entire control system network.

These modules perform specific unit functions using proportional/integral control algorithms. They are mounted in the unit control panel and are factory wired to their respective internal components. Each module receives and interprets information from other unit modules, sensors, remote panels, and customer binary contacts to satisfy the applicable request; i.e., economizing, mechanical cooling, heating, ventilation.

Following is a detailed description of each module's function.

RTM Module Board - Standard on all Units

The RTM responds to cooling, heating, and ventilation requests by energizing the proper unit components based on information received from other unit modules, sensors, remote panels, and customer supplied binary inputs. It initiates supply fan, exhaust fan, exhaust damper, or variable frequency drive output, and airside economizer operation based on that information.

Reference the RTM points list on page 70.

Note: *Emergency stop and external auto/stop, stop the unit immediately, emergency stop generates a manual reset diagnostic that must be reset at the unit human interface. External auto-stop will return the unit to the current operating mode when the input is closed, so this input is auto reset.*

RTM Remote Economizer Minimum Position

The remote minimum position potentiometer, BAYSTAT023A, provides a variable resistance (0-270 ohms) to adjust the economizer minimum position from 0 to 100% when connected to the economizer remote minimum position input of the RTM. The RTM must be selected as the source for economizer minimum position. If the RTM is the selected source for economizer minimum position, and if a valid resistance per [Table 39, p. 64](#) is provided to the RTM remote minimum position input, the OA cfm compensation function will not operate, even if enabled "Default" is the only possible source for

economizer minimum position when using the OA cfm compensation function.

Table 39. Economizer remote minimum position input resistance

Input Resistance	Economizer Min. Position
0 - 30 ohms	0%
30 - 240 ohms	0-100% (linear)
240 - 350 ohms	100%
> 350 ohms	N/A ^(a)

(a) A resistance greater than 350 ohms is assumed to be an open circuit. The system will use the default minimum position value.

RTM Analog Outputs

The RTM has two 0-10 vdc outputs: one for the economizer option. This output provides a signal for one or two damper actuators. There are no terminal strip locations associated with these wires. They go directly from pins on the RTM circuit board to the actuator motor.

RTM Binary Outputs

The RTM has an output with pressure switch proving inputs for the supply fan. There is a 40 second delay from when the RTM starts the supply fan until the fan proving input must close. A fan failure diagnostic will occur after 40 seconds. This is a manual reset diagnostic, and all heating, cooling, and economizer functions will shut down. If this proving input is jumped, other nuisance diagnostics will occur. If the proving input fails to close in 40 seconds, the economizer cycles to the minimum position. This is a manual reset diagnostic. External control of the fan is not recommended.

VAV Drive Max Output

This is a single-pole, double-throw relay rated at a maximum voltage of 24 vac, two amps. The relay contacts of this relay switch when the unit goes from the occupied mode to the unoccupied mode by means of the occupied binary input. The contacts will stay switched during the unoccupied and morning warm-up mode. They will return to the position shown on the unit wiring diagram when the unit returns to the occupied mode. This binary output signals the VAV boxes or other terminal devices to go full open.

RTM Alarm Relay

This is a single pole, double throw relay rated at a maximum voltage of 24 vac, two amps max. Relay contacts can be programmed from the unit human interface. This relay can be programmed to pick up on any one or group of diagnostics from the unit human interface.

Status/Annunciator Output

The status annunciator output is an internal function within the RTM module on CV and VAV units. It provides:

- a. diagnostic and mode status signals to the remote panel (LEDs) and to the Human Interface.
- b. control of the binary alarm output on the RTM.
- c. control of the binary outputs on the GBAS module to inform the customer of the operational status and/or diagnostic conditions.

Occupied/Unoccupied Inputs

There are four ways to switch to occupied/unoccupied:

1. Field-supplied contact closure hard wired binary input to the RTM
2. Programmable night setback zone sensor
3. Tracer Summit
4. Factory-mounted time clock

VAV Changeover Contacts

These contacts are connected to the RTM when daytime heating on VAV units with internal or external hydronic heat is required. Daytime (occupied) heating switches the system to a CV unit operation. Refer to the unit wiring diagram for the field connection terminals in the unit control panel. The switch must be rated at 12 ma @ 24VDC minimum.

External Auto/Stop Switch

A field-supplied switch may be used to shut down unit operation. This switch is a binary input wired to the RTM. When opened, the unit shuts down immediately and can be cancelled by closing the switch. Refer to the unit wiring diagrams (attached to the unit control panel) for proper connection terminals. The switch must be rated for 12 ma @ 24 VDC minimum. This input will override all VOM inputs, if the VOM option is on the unit.

Occupied/Unoccupied Contacts

To provide night setback control if a remote panel with night setback was not ordered, install a field-supplied contact. This binary input provides the building's occupied/unoccupied status to the RTM. It can be initiated by a time clock, or a building automation system control output. The relay's contacts must be rated for 12 ma @ 24 VDC minimum. Refer to the appropriate wiring diagrams (attached to the unit control panel for the proper connection terminals in the unit control panel.

Emergency Stop Input

A binary input is provided on the RTM board for installation of a field-supplied normally closed (N.C.) switch to use during emergency situations to shut down all unit operations. When open, an immediate shutdown occurs. An emergency stop diagnostic enters the human interface and the unit will require a manual reset. Refer to the unit wiring diagrams (attached to the unit control panel for the proper connection terminals. The switch must be rated for 12 ma @ 24 VDC minimum. This input will override all VOM inputs, if the VOM option is on the unit.

VAV Box Option

To interlock VAV box operation with evaporator fan and heat/cool modes, wire the VAV boxes/air valves to VAV box control connections on the terminal block.

Supply Duct Static Pressure Control

The RTM relies on input from the duct pressure transducer when a unit is equipped with VFD to set the supply fan speed to maintain the supply duct static pressure to within the static pressure setpoint deadband.

RTM Sensors

RTM sensors include: zone sensors with or without setpoint inputs and modes, supply air sensor, duct static pressure, outside air temperature, outside air humidity, airflow proving, and dirty filter.

Table 40. RTM sensor resistance vs. temperature

Temperature °F	Resistance V ohms	Temperature °F	Resistance V ohms
-40	346.1	71	11.60
-30	241.7	72	11.31
-20	170.1	73	11.03
-10	121.4	74	10.76
-5	103.0	75	10.50
0	87.56	76	10.25
5	74.65	77	10.00
10	63.8	78	9.76
15	54.66	79	6.53
20	46.94	80	9.30
25	40.40	85	8.25
30	34.85	90	7.33
35	30.18	100	5.82
40	26.22	105	5.21
45	22.85	110	4.66
50	19.96	120	3.76
55	17.47	130	3.05
60	15.33	140	2.50
65	13.49	150	2.05
66	13.15	160	1.69
67	12.82	170	1.40
68	12.50	180	1.17
69	12.19	190	0.985
70	11.89	200	0.830

Table 41. RTM setpoint analog inputs

Cooling or Heating Setpoint Input, °F (using RTM as zone temp. source) ohms	Cooling Setpoint Input, °F (using RTM as supply air temp. source) resistance, V
40	1084
45	992



Controls

Table 41. RTM setpoint analog inputs

Cooling or Heating Setpoint Input, °F (using RTM as zone temp. source) ohms	Cooling Setpoint Input, °F (using RTM as supply air temp. source) resistance, V	
50	50	899
55	55	796
60	60	695
65	65	597
70	70	500
75	75	403
80	80	305
NA	85	208
NA	90	111

Table 42. RTM resistance value vs. system operating mode

Resistance applied to RTM mode input terminals, ohms	CV units		VAV units
	fan mode	system mode	system mode
2320	auto	off	off
4870	auto	cool	
7680	auto	auto	auto
10,770	on	off	
13,320	on	cool	
16,130	on	auto	
19,480	auto	heat	
27,930	on	heat	

Note: Mode boundaries are 1000 to 40,000 ohms. Other boundaries are equal to the midpoint between the nominal mode resistance.

Compressor Module (MCM) - Standard on all Units

The compressor module, (single circuit and multiple circuit) energizes the appropriate compressors and condenser fans upon receiving a request for mechanical cooling. It monitors the compressor operation through feedback information it receives from various protection devices.

Human Interface Module - Standard on all Units

The human interface (HI) module enables the operator to adjust the operating parameters for the unit using its 16-key keypad on the human interface panel. The HI panel provides a two line, 40 character, clear language (English, Spanish, or French) LCD screen with unit status information and menus to set or modify operating parameters. It is mounted in the unit's main control panel and accessible through the unit's control panel door.

Remote Human Interface Module Option

The optional remote-mount human interface (RHI) panel has all the functions of the unit-mounted version except

for service mode. To use a RHI, the unit must be equipped with an optional interprocessor communications bridge (IPCB). Model number digit 32 (=2) indicates if the IPCB was ordered with the unit. If not, contact your local Trane representative to order an IPCB kit for field installation. The RHI can be located up to 1,000 feet (304.8 m) from the unit. A single RHI can monitor and control up to four self-contained units if each one contains an IPCB. The IPCB switches must be set as SW1- off, SW2 - off, and SW3 - on.

Interprocessor Communications Board • Option used with RHI

The interprocessor communication board expands communications from the rooftop unit's UCM network to a remote human interface panel. DIP switch settings on the IPCB module for this application are; switches 1 and 2 "off," switch 3 "on."

Waterside Module - Standard on all water-cooled units

The waterside module (WSM) controls all water valves based on unit configuration. In addition, the WSM monitors waterflow proving and the following temperatures:

- entering water
- entering air low
- mixed air
- entering condenser water
- refrigerant circuit 3:
 - saturated condenser
 - evaporator frost
- refrigerant circuit 4:
 - condenser
 - evaporator

Cooling Tower Interlock

To interlock condenser pump/tower with cooling operation, wire the cooling tower to an external 115 volt control power source, to ground, and to control terminal block. Normally open/closed contacts are provided.

Heat Module

The heat module is standard on all units with factory-installed heat. It controls the unit heater to stage up and down to bring the temperature in the controlled space to within the applicable heating setpoint. Also, it includes a freeze-stat, morning warmup, and heating outputs.

Ventilation Override Module (VOM) Option

The ventilation override module can be field-configured with up to five different override sequences for ventilation override control purpose. When any one of the module's five binary inputs are activated, it will initiate specified

functions such as; space pressurization, exhaust, purge, purge with duct pressure control, and unit off.

Once the ventilation sequences are configured, they can be changed unless they are locked using the HI. Once locked, the ventilation sequences cannot be unlocked.

The compressors and condenser fans disable during the ventilation operation. If more than one ventilation sequence activates, the one with the highest priority (VOM "A") begins first, with VOM "E" having lowest priority and beginning last.

A description of the VOM binary inputs follows below.

UNIT OFF sequence "A"

When complete system shut down is required, the following sequence can be used.

- Supply fan – off
- Supply fan VFD – off (0 Hz)
- Outside air dampers – closed
- Heat – all stages – off, modulating heat output at 0 vdc
- Occupied/Unoccupied output – de-energized
- VO relay – energized
- Exhaust fan (field-installed) - off
- Exhaust damper (field-installed) - closed

PRESSURIZE sequence "B"

This override sequence can be used if a positively pressured space is desired instead of a negatively pressurized space.

- Supply fan – on
- Supply fan VFD – on (60 Hz)/VAV boxes – open
- Outside air dampers – open
- Heat – all stages – off, hydronic heat output at 0 vdc
- Occupied/ unoccupied output - energized
- VO relay - energized
- Exhaust fan (field-installed) - off
- Exhaust damper (field-installed) - closed

EXHAUST sequence "C"

With the building's exhaust fans running and the unit's supply fan off, the conditioned space becomes negatively pressurized. This is desirable for clearing the area of smoke when necessary; i.e. from an extinguished fire, to keep smoke out of areas that were not damaged.

- Supply fan – off
- Supply fan VFD – off (0 Hz)
- Outside air dampers – closed
- Heat – all stages – off, hydronic heat output at 0 vdc
- Occupied/Unoccupied output – de-energized
- VO relay – energized
- Exhaust fan (field-installed) - on

- Exhaust damper (field-installed) - open

PURGE sequence "D"

This sequence can purge the air out of a building before coming out of unoccupied mode of operation in a VAV system. Also, it can be used to purge smoke or stale air.

- Supply fan – on
- Supply fan VFD – on (60 Hz)/VAV boxes – open
- Outside air damper – open
- Heat – all stages – off, modulating heat output at 0 vdc
- Occupied/Unoccupied output – energized
- VO relay – energized
- Exhaust fan (field-installed) - on
- Exhaust damper (field-installed) - open

PURGE with duct pressure control "E"

This sequence can be used when supply air control is required for smoke control.

- Supply fan – on
- Supply fan VFD – on (if equipped)
- Outside air dampers – open
- Heat – all stages – off, hydronic heat output at 0 vdc
- Occupied/unoccupied output – energized
- VO relay – energized
- Exhaust fan (field-installed) - on
- Exhaust damper (field-installed) - open

Note: Each system (cooling, exhaust, supply air, etc.) within the unit can be redefined in the field for each of the five sequences, if required. Also the definitions of any or all of the five sequences may be locked into the software by simple key strokes at the human interface panel. Once locked into the software, the sequences cannot be changed.

LonTalk® Communications Interface (LCI-I) Module

The LonTalk Communication Interface for IntelliPak self-contained (LCI-I) controller expands communications from the unit UCM network to a Trane Tracer Summit or a 3rd party building automation system, utilizing LonTalk, and allows external setpoint and configuration adjustment and monitoring of status and diagnostics. The LCI-I utilizes an FTT-10A Free Topology transceiver, which supports nonpolarity sensitive, free topology wiring, which allows the system installer to utilize star, bus, and loop architectures. This controller works in standalone mode, peer-to-peer with one or more other units, or when connected to a Trane Tracer Summit or a 3rd party building automation system that supports LonTalk.

BACnet® Communications Interface (BCI-I) Module

The BACnet® Communication Interface for IntelliPak self-contained (BCI-I) controller expands communications from the unit UCM network to Tracer SC or a 3rd party building automation system, utilizing BACnet, and allows external setpoint and configuration adjustment and monitoring of status and diagnostics. The BCI-I utilizes the BACnet defined MS/TP protocol as defined in ASHRAE standard 135-2004. This controller works in standalone mode, with Tracer SC or when connected to a 3rd party building automation system that supports BACnet.

Exhaust/Comparative Enthalpy (ECEM) Module

(Option used on units with comparative enthalpy option)

The exhaust/comparative enthalpy module receives information from the return air humidity sensor, and the RTM outside air temperature sensor and outside air humidity sensor, the outside air humidity sensor and

temperature sensor to utilize the lowest possible enthalpy level when considering economizer operation. In addition, it receives space pressure information to maintain the space pressure within the setpoint control band. Refer to the [Figure 40, p. 68](#) for humidity vs. voltage values.

Figure 40. Relative humidity vs. voltage

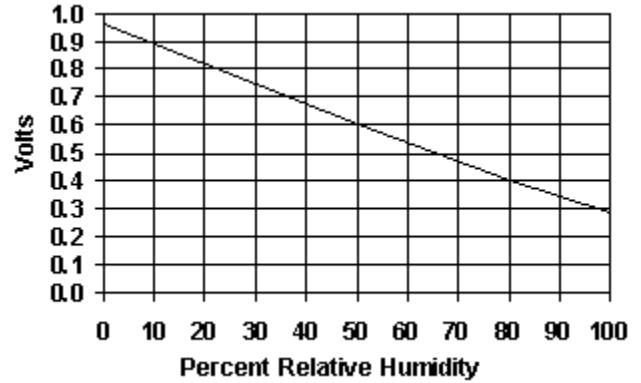
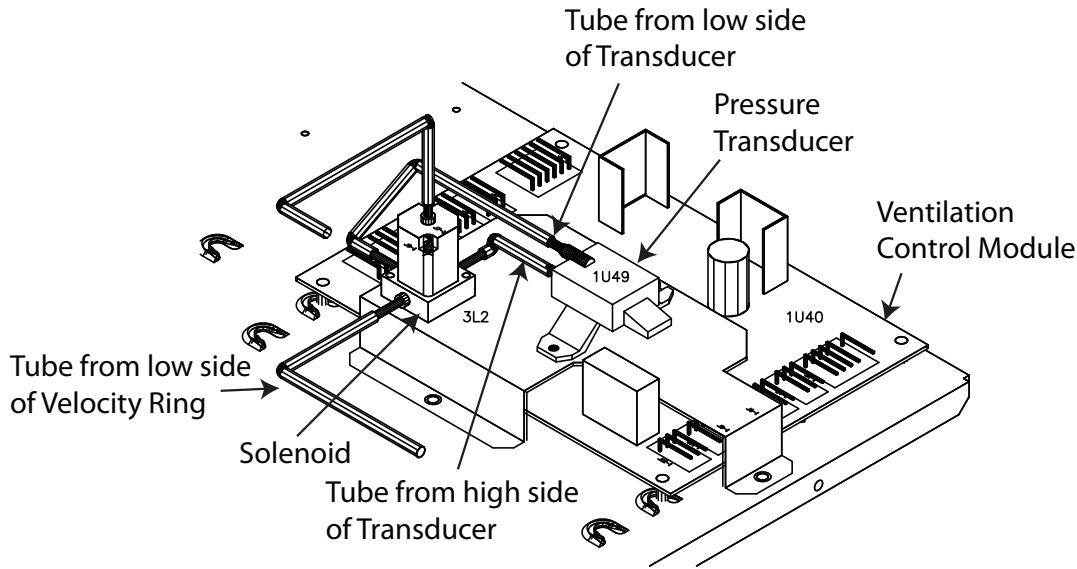

Figure 41. Velocity pressure transducer/solenoid assembly



Ventilation Control Module (VCM)

(Available only with Traq™ Damper Option)

The ventilation control module (VCM) is located in the airside economizer section of the unit and linked to the unit's UCM network. Using a velocity pressure transducer/solenoid (pressure sensing ring) in the fresh air section allows the VCM to monitor and control fresh air entering the unit to a minimum airflow setpoint. See [Figure 41, p. 68](#) for a detail view of the velocity pressure transducer/solenoid assembly.

An optional temperature sensor can be connected to the VCM to enable control of a field installed fresh air preheater.

Also, a field-provided CO2 sensor can be connected to the VCM to control CO2 reset. The reset function adjusts the minimum cfm upward as the CO2 concentrations increase. The maximum effective (reset) setpoint value for fresh air entering the unit is limited to the system's operating cfm. [Table 43, p. 69](#) lists the minimum outside air cfm vs. input voltage.

Table 43. Minimum outside air setpoint w/VCM module and Traq™ sensing

Unit	Input volts	Cfm
SXWF 20	0.5 - 4.5 vdc	6,325-8,500
SXWF 22	0.5 - 4.5 vdc	6,325-9,350
SXWF 25	0.5 - 4.5 vdc	6,500-10,625
SXWF 29	0.5 - 4.5 vdc	8,700-12,325
SXWF 32	0.5 - 4.5 vdc	8,700-13,600
SXWF 35	0.5 - 4.5 vdc	9,100-14,875
SXWF 38	0.5 - 4.5 vdc	9,880-16,150
SXWF 42	0.5 - 4.5 vdc	11,200-17,859
SXWF 46	0.5 - 4.5 vdc	11,960-19,550
SXWF 52	0.5 - 4.5 vdc	14,250-22,100
SXWF 58	0.5 - 4.5 vdc	15,080-24,650
SXWF 65	0.5 - 4.5 vdc	16,900-27,625
SXWF 72	0.5 - 4.5 vdc	18,700-29,800
SXWF 80	0.5 - 4.5 vdc	20,800-29,800
SXRF 20	0.5 - 4.5 vdc	6,500-10,625
SXRF 25	0.5 - 4.5 vdc	8,700-12,325
SXRF 29	0.5 - 4.5 vdc	8,700-13,600
SXRF 30	0.5 - 4.5 vdc	9,100-14,875
SXRF 35	0.5 - 4.5 vdc	9,880-16,150
SXRF 40	0.5 - 4.5 vdc	11,960-19,550
SXRF 50	0.5 - 4.5 vdc	15,080-24,650
SXRF 60	0.5 - 4.5 vdc	20,800-29,800

Generic Building Automation System Module Option

Generic building automation system module (GBAS) provides broad control capabilities for building automation systems other than Trane's Tracer™ system. A field provided potentiometer or a 0-5 vdc signal can be applied to any inputs of GBAS to provide following points:

GBAS Analog Inputs

Four analog inputs that can be configured to be any of the following:

1. occupied zone cooling
2. unoccupied zone cooling
3. occupied zone heating
4. unoccupied zone heating
5. SA cooling setpoint
6. SA heating setpoint
7. space static pressure setpoint
8. SA static pressure setpoint

GBAS Binary Outputs

Five binary outputs to provide diagnostics, signaling up to five alarms. Each of the five (5) relay outputs can be mapped to any/all of the available diagnostics. Each output contains a dry N.O. and N.C. contact with a VA rating of 2 amps at 24 VAC.

GBAS Binary Input

One binary input for the self-contained unit to utilize the demand limit function. This function is operational on units with a GBAS and is used to reduce electrical consumption at peak load times. Demand limiting can be set at either 50% or 100%. When demand limiting is needed, mechanical cooling and heating (with field-provided 2-stage electric heat only) operation are either partially (50%), or completely disabled (100%) to save energy. The demand limit definition is user definable at the HI panel. Demand limit binary input accepts a field supplied switch or contact closure. When the need for demand limiting has been discontinued, the unit's cooling/heating functions will again become fully enabled.

GBAS Communication (Analog Inputs)

The GBAS accepts external setpoints in the form of analog inputs for cooling, heating, supply air pressure. Refer to the unit wiring diagram for GBAS input wiring and the various desired setpoints with the corresponding DC voltage inputs.

Any of the setpoint or output control parameters can be assigned to each of the four analog inputs on the GBAS module. Also, any combination of the setpoint and/or output control parameters can be assigned to the analog inputs through the HI. To assign the setpoints apply an external 0-5 vdc signal:

1. directly to the signal input terminals, or
2. to the 5 vdc source at the GBAS module with a 3-wire potentiometer.

Note: *There is a regulated 5 vdc output on the GBAS module that can be used with a potentiometer as a voltage divider. The recommended potentiometer value is 1000-100,000 ohms.*

The setpoints are linear between the values shown in Table 44, p. 70. Reference Table 45, p. 70 for corresponding input voltage setpoints. Following are formulas to calculate input voltage or setpoint. SP = setpoint, IPV = input voltage.

If the setpoint range is 50-90°F:

$$IPV = (SP - 50)(0.1) + 0.5$$

$$SP = [(IPV - 0.5)/0.1] + 50$$

If the setpoint range is 40-90°F:

$$IPV = (SP - 40)(0.8) + 0.5$$

$$SP = [(IPV - 0.5)/0.08] + 40$$

If the setpoint range is 40-180°F:

$$IPV = (SP - 40)(0.029) + 0.5$$

$$SP = [(IPV - 0.5)/0.029] + 40$$

If the static pressure range is 0.03-0.3 iwc:

$$IPV = (SP - 0.03)(14.8) + 0.5$$

$$SP = [(IPV - 0.5)/14.8] + 0.03$$



Controls

If the static pressure range is 0.0-5.0 iwc:

$$IPV = (SP)(0.8) + 0.5$$

$$SP = [IPV / (0.8 + 0.5)]$$

GBAS Demand Limit Relay (Binary Input)

The GBAS allows the unit to utilize the demand limit function by using a normally open (N.O.) switch to limit the electrical power usage during peak periods. Demand limit can initiate by a toggle switch closure, a time clock, or an ICS control output. These contacts must be rated for 12 ma @ 24 VDC minimum.

When the GBAS module receives a binary input signal indicating demand limiting is required, a command initiates to either partially (50%) or fully (100%) inhibit compressor and heater operation. This can be set at the HI using the setup menu, under the "demand limit definition cooling" and "demand limit definition heating" screens. A toggle switch, time clock, or building automation system control output can initiate demand limiting.

If the cooling demand limit is set to 50%, half of the cooling capacity will disable when the demand limit binary input closes. The heating demand limit definition can only be set at 100%, unless the unit has field-provided two-stage electric heat. In that case, if the heating demand limit is set to 50%, half or one stage of heating disables when the demand limit binary input closes. If the demand limit definition is set to 100%, then all cooling and/or heating will disable when the demand limit input closes.

GBAS Diagnostics (Binary Outputs)

The GBAS can signal up to five alarm diagnostics, which are fully mappable through the setup menu on the HI. These diagnostics, along with the alarm output on the RTM, allow up to six fully mappable alarm outputs.

Each binary output has a NO and NC contact with a rating of two amps at 24 VAC. The five binary outputs are factory preset as shown on the unit wiring diagram (on the unit control panel door). However, these outputs can be field defined in a variety of configurations, assigning single or multiple diagnostics to any output.

For a complete listing of possible diagnostics, see the *IntelliPak Self-Contained Programming Guide, PKG-SVP01B-EN*. For terminal strip locations, refer to the unit wiring diagram for the GBAS.

Table 44. GBAS analog input setpoints

Control Parameter	Signal Range VDC	Setpoint Range °F
occupied zone cooling setpoint (CV units only)	0.5 to 4.5	50 to 90°F
unoccupied zone cooling setpoint (CV and VAV)	0.5 to 4.5	50 to 90°F
occupied zone heating setpoint (CV units only)	0.5 to 4.5	50 to 90°F
unoccupied zone heating setpoint	0.5 to 4.5	50 to 90°F

Table 44. GBAS analog input setpoints (continued)

Control Parameter	Signal Range VDC	Setpoint Range °F
(CV and VAV)		
supply air cooling setpoint (VAV units only)	0.5 to 4.5	40 to 90°F
supply air hydronic heating setpoint (VAV units only)	0.5 to 4.5	40 to 180 F
space static pressure setpoint	0.5 to 4.5	0.03 to 0.30 IWC
supply air pressure setpoint (VAV units only)	0.5 to 4.5	0.0 to 5.0 IWC

Note:

1. Input voltages less than 0.5 vdc are considered as 0.5 vdc input signal is lost, the setpoint will "clamp" to the low end of the setpoint scale. No diagnostic will result from this condition.
2. Input voltages greater than 4.5 vdc are considered to be 4.5 vdc.
3. The actual measured voltage is displayed at the HI.

Table 45. GBAS input voltage corresponding setpoints

Volts	Temp. °F	Volts	Temp. °F	Volts	Temp. °F	Volts	Temp. °F
0.5	50	1.6	60	2.6	70	2.7	80
0.6	51	1.7	61	2.7	71	2.8	81
0.7	52	1.8	62	2.8	72	2.9	82
0.8	53	1.9	63	2.9	73	3.0	83
0.9	54	2.0	64	3.0	74	3.1	84
1.0	55	2.1	65	3.1	75	3.2	85
1.1	56	2.2	66	3.2	76	3.3	86
1.2	57	2.3	67	3.3	77	3.4	87
1.3	58	2.4	68	3.4	78	3.5	88
1.5	59	2.5	69	3.5	79	3.6	89

Input Devices and System Functions

Following are basic input device and system function descriptions used within the UCM network on IntelliPak™ self-contained units. Refer to the unit wiring diagrams for specific connections.

Water Purge

NOTICE:

Proper Water Treatment!

The use of untreated or improperly treated water in coils could result in scaling, erosion, corrosion, algae or slime. It is recommended that the services of a qualified water treatment specialist be engaged to determine what water treatment, if any, is required. Trane assumes no responsibility for equipment failures which result from untreated or improperly treated water, or saline or brackish water.

During the unoccupied mode, water-cooled units will periodically circulate water through the condensers and

waterside economizer if the user has enabled the purge function at the HI. The water purge function circulates water to introduce fresh water-treatment chemicals and help prevent water stagnation. The number of hours between each periodic purge, or purge duration, is user-defined at the HI between 1-999 hours. If the periodic purge timer expires while the unit is in occupied mode, it will wait for the next available unoccupied time before initiating water purge. Contrary, if a request for cooling occurs during a purge sequence, purge will terminate and cooling will commence.

Compressor Circuit Breakers

The compressors are protected by circuit breakers that interrupt the compressor power supply if the current exceeds the breakers "must trip" value. During a request for compressor operation, if the compressor module (MCM or SCM) detects a problem outside of its normal parameters, it turns any operating compressor(s) on that circuit off, locks out all compressor operation for that circuit, and initiates a manual reset diagnostic.

Low Pressure Control

Low pressure (LP) control is accomplished using a binary input device mounted on the suction line, near the compressor. If suction pressure drops to 49 (water-cooled), 36 (air-cooled) \pm 6 psig, or below, the switch opens.

If the switch is open at start, no compressors on that circuit will operate. They are locked out and a manual reset diagnostic initiates. If the LP switch opens after a compressor start, all compressors on that circuit will stop and remain off a minimum 3 minutes before restarting. If the LP cutout trips four times in the first three minutes of operation, all compressors on that circuit lockout and a manual reset diagnostic initiates.

LP switches close at 74 (water-cooled) and 61 (air-cooled) \pm 6 psig.

Evaporator Temperature Sensor Frostat™

The evaporator temperature sensor is an analog input device used to monitor refrigerant temperature inside the evaporator coil to prevent coil freezing. It is attached to the suction line near the evaporator coil with circuits 1 and 2 connected to the SCM/MCM and circuits 3 and 4 connected to the WSM. The coil frost cutout temperature is factory set at 30°F. It is adjustable at the HI from 25-35°F. The compressors stage off as necessary to prevent icing. After the last compressor stages off, the compressors will restart when the evaporator temperature rises 10°F above the coil frost cutout temperature and the minimum three minute "off" time elapses.

Saturated Condenser Temperature Sensors

The saturated condenser temperature sensors are analog input devices. They are mounted inside a temperature well located on a condenser tube bend on air-cooled units, and in the condenser shell on water-cooled units. The sensors

monitor the saturated refrigerant temperature inside the condenser coil and are connected to the SCM/MCM for circuits 1 and 2 (air or water cooled), and WSM for circuits 3 and 4 (only water-cooled).

Head Pressure Control

Head pressure control is accomplished using two saturated refrigerant temperature sensors on air-cooled units and up to four sensors on water-cooled units.

Air-cooled units. During a request for compressor operation when the condensing temperature rises above the lower limit of the control band, the compressor module (SCM/MCM) sequences condenser fans on. If the operating fans cannot bring the condensing temperature to within the control band, more fans turn on. As the saturated condensing temperature approaches the lower limit of the control band, fans sequence off. The minimum on/off time for condenser fan staging is 5.2 seconds. If the system is operating at a given fan stage below 100% for 30 minutes the saturated condensing temperature is above the efficiency check point setting, a fan stage will be added. If the saturated condensing temperature falls below the efficiency check point setting, fan control remains at the present operating stage. If the fan stage cycles four times within a 10 minute period, the lower limit temperature is redefined as being equal to the lower limit minus the temporary low limit suppression setting. The unit will utilize this new low limit temperature for one hour to reduce condenser fan short cycling.

Water-cooled. Units without WSE, the condenser valve modulates to maintain an average saturated condenser temperature. Units with WSE, if economizing and mechanical cooling is necessary the economize valve will sacrifice free cooling and modulate to maintain condensing saturated temperature. If not economizing, the condenser valve will modulate to maintain condensing saturated temperature. Water-cooled units without head pressure control will lock out mechanical cooling at entering condenser water temperatures below 54°F. Mechanical cooling will resume when the entering condenser water temperature exceeds 58°F.

Low Ambient Control (Air-Cooled Units Only)

The low ambient modulating output on the compressor module is functional on all units with or without the low ambient option. When the compressor module stages up to its highest stages 2 or 3 depending on unit size), the modulating output is 100% (10 VDC). When the control is at stage 1, the modulating output (0-10 VDC) controls the saturated condensing temperature to within the programmable condensing temperature low ambient control point.

Low Ambient Compressor Lockout (Air-Cooled Units Only)

The low ambient compressor lockout utilizes an analog input device. When the system is configured for low ambient compressor lockout, the compressors will not



Controls

operate if the temperature of the outside air falls below the lockout setpoint. When the temperature rises 5°F above the lockout setpoint, the compressors will operate. The setpoint for units without the low ambient option is 50°F. For units with the low ambient option, the setpoint is 0°F. The setpoints are adjustable at the human interface panel.

Return Air Temperature Sensor

The return air temperature sensor is an analog input device used with a return humidity sensor on units with the comparative enthalpy option. The sensor monitors the return air temperature and compares it to the outdoor temperature to establish which temperature is best suited to maintain cooling requirements. It is mounted in the return air path and connected to the ECEM.

Supply Fan Circuit Breaker, Fuses, and Overloads

The supply fan motor is protected by either circuit breakers fuses or a combination of fuses and overloads, dependent upon unit configuration. Circuit breakers are used on units without a VFD. They will trip and interrupt the motor power supply if the current exceeds the breaker trip value. The RTM shuts all system functions off when detecting an open fan proving switch. Units with a VFD have fuses to protect the VFD and motor. Units with a VFD w/bypass have fuses to protect VFD circuit and overloads to protect the motor when in bypass.

Supply Air Temperature Low Limit

The supply air temperature low limit function uses the supply air temperature sensor input to modulate the economizer damper to the minimum position if the supply air temperature falls below the occupied heating setpoint temperature.

Supply Air Temperature Sensor

The supply air temperature sensor is an analog input device. It monitors the supply air temperature for supply air temperature control, supply air temperature reset, supply air temperature low limiting, and supply air tempering. It is mounted in the supply air discharge section of the unit and connected to the RTM.

Supply Airflow Proving Switches

This is binary input device used on units to signal the RTM when the supply fan is operating. It is mounted in the supply fan section and is connected to the RTM. During a request for fan operation and if the differential switch opens for 40 consecutive seconds, compressor operation turns off, heat operation turns off, the request for supply fan operation turns off and locks out, economizer damper option closes, and a manual reset diagnostic initiates.

Low Entering Air Protection Device (LEATPD)

The low entering air protection device (LEATPD) is a binary input on units with hydronic heat or a waterside economizer. It is optional on water-cooled units.

If the LEATPD is on a unit with factory-installed heat, it is mounted in the heat section and connected to the heat module. If the entering air temperature to the heating coil falls to 40°F, the normally open contacts on the LEATPD close and cause the following events:

- a. the hydronic heat actuator fully opens.
- b. the supply fan turns off
- c. the outside air damper closes
- d. the SERVICE light at the remote zone sensor option turns on.
- e. a LEATPD diagnostic displays at the human interface panel.

If the LEATPD is on a water-cooled unit without factory-installed heat, it is wired to the WSM. It will trip if the entering water temperature falls to 34°F, open the economizer valve, and energize the pump output.

High Duct Temp Thermostat Option On Units with a TCI

The high duct temperature thermostats are binary input devices used on units with a Trane communication interface module (TCI). They provide a high limit unit shutdown and require a manual reset. The thermostats are factory set to open if the supply air temperature reaches 240°F, or the return air temperature reaches 135°F. Once tripped, the thermostat requires a manual reset. Reset by pressing the sensor's reset button when the air temperature decreases approximately 25°F below the cutout point.

Filter Switch

The filter switch is a binary input device that measures the pressure differential across the unit filters. It is mounted in the filter section and connected to the RTM. A diagnostic SERVICE signal displays at the remote panel if the pressure differential across the filters is at least 0.5" w.c. The contacts automatically open when the pressure differential across the filters decrease to 0.4" w.c. The switch differential is field adjustable between 0.17" to 5.0" w.c. ± 0.05 "

High Duct Static Switch Option

The high duct static switch is field-mounted in the ductwork or plenums with smoke dampers. It will cause a manual reset diagnostic if the duct static exceeds the pre-set static limit. The static limit is adjustable at the HI.

Pre-Start

Before starting up units perform the following procedures to ensure proper unit operation.

Units with VFD

This panel is hinged to allow service access to fan motor and belt drive components that are located behind it.

Note: The panel weight rating is 225 lbs. total including factory-installed components.

To swing the panel open:

WARNING

Proper Field Wiring and Grounding Required!

All field wiring **MUST** be performed by qualified personnel. Improperly installed and grounded field wiring poses **FIRE** and **ELECTROCUTION** hazards. To avoid these hazards, you **MUST** follow requirements for field wiring installation and grounding as described in **NEC** and your local/state electrical codes. Failure to follow code could result in death or serious injury.

WARNING

Hazardous Voltage w/Capacitors!

Disconnect all electric power, including remote disconnects and discharge all motor start/run capacitors before servicing. Follow proper lockout/tagout procedures to ensure the power cannot be inadvertently energized. For variable frequency drives or other energy storing components provided by Trane or others, refer to the appropriate manufacturer's literature for allowable waiting periods for discharge of capacitors. Verify with an appropriate voltmeter that all capacitors have discharged. Failure to disconnect power and discharge capacitors before servicing could result in death or serious injury.

For additional information regarding the safe discharge of capacitors, see *PROD-SVB06A-EN*

1. Remove the unit center cover panel to the left of the VFD panel.
2. Verify/remove/discard the sheet metal shipping screws along the top and bottom edges of the VFD panel.
3. Disconnect the communications cable from the keypad on the VFD door panel.
4. Turn the two slotted-head fasteners on the right edge of the VFD panel fully counterclockwise.
5. Pull on the handle to swing the panel 180°.

Note: To secure the panel in the open position during service procedures, attach the chain mounted to the cabinet frame behind the unit center cover panel to the chain retainer notch on the edge of the VFD panel.

To close and reattach the panel, reverse the above procedures.

Note: Verify that all wires are in proper position and not rubbing once the panel has been secured.

Pre-Start Checklist

Complete this checklist after installing unit to verify all recommended installation procedures are complete before start-up. This does not replace the detailed instructions in the appropriate sections of this manual. Always read the entire section carefully to become familiar with the procedures.

Supply Fan

- Verify the fan and motor shafts are parallel.
- Verify the fan and motor sheaves are aligned.
- Check the fan belt condition and tension. Adjust the tension if belts are floppy or squeal continually. Replace worn or fraying belts in matched sets.
- Ensure the fan rotates freely.
- Tighten locking screws, bearing set screws and sheaves.
- Ensure bearing locking collars do not wobble when rotated.
- Remove fan assembly tie down bolts. On 20 - 38 ton units, do not remove the fan assembly tie down bolts if the fan speed is 750 rpm or less.
- Ensure fan rotation is in direction of arrow on fan housing. If incorrect, verify incoming power phasing is correct. Switch wires on the fan contact to properly phase fan if necessary.

Ductwork

- Ensure trunk ductwork to VAV boxes is complete and secure to prevent leaks.
- Verify that all ductwork conforms to NFPA 90A or 90B and all applicable local codes

Water-Cooled Unit Piping

- Verify condensate drain, water piping drain plugs, economizer header, and condenser vent plug are installed.

Air-Cooled Units Only

- Verify leak test was performed after refrigerant piping was installed.
- Verify liquid line filter driers installed.

Units with Hydronic Heat

- Verify the entering water temperature sensor is installed upstream of the hydronic coil.



Pre-Start

Units with Electric Heat

- Verify the supply air temperature sensor is downstream of the electric heat coil.

Electrical

- Verify electrical connections are tight.

Components

- Verify liquid line service valve, and suction and discharge service valves if present, are open at startup.

Note: *Each compressor suction line contains a low pressure sensor that will shut the compressor down in low pressure situations. See [Table 36](#), p. 56.*

- Ensure system components are properly set and installed.

Note: *Thermal expansion valve superheat is factory set and requires no field adjustment. Operating superheat should be between 14-20°F. Actual superheat depends on several factors (operating conditions, system load step, system charge, piping and condenser head pressure control.)*

Start-Up

⚠ WARNING

Live Electrical Components!

During installation, testing, servicing and troubleshooting of this product, it may be necessary to work with live electrical components. Have a qualified licensed electrician or other individual who has been properly trained in handling live electrical components perform these tasks. Failure to follow all electrical safety precautions when exposed to live electrical components could result in death or serious injury.

NOTICE:

Compressor Damage!

Never manually or automatically pump down system below 7 psig. This will cause the compressor to operate in a vacuum and result in compressor damage.

NOTICE:

Compressor Damage!

Keep crankcase heaters on whenever refrigerant is in the system. If crankcase heaters have not been on with refrigerant in the system, turn the crankcase heaters on for a minimum of 24 hours before starting compressors. Failure to follow the above could result in compressor failure or reduced compressor life.

To start the unit, complete the following steps in order.

Review “Preliminary Refrigerant Charging,” p. 35 in if applicable. Confirm all steps were completed.

Air Cooled Only

- Charging is more accurate at higher outdoor temperatures. If outdoor temperature is < 80°F, temporarily disable fan pressure control switches. See unit wiring diagrams and disconnect the wires between switches and terminal strip.
- Do not attempt to charge system with low ambient dampers operating (if applicable). Disable these dampers in “Open” position before proceeding.

Evaporator load should be at least 70°F return air, 350 CFM/ton.

Work on only one circuit at a time. See section “General Data,” p. 11 for compressor sequencing.

Note: R-410A compressors have belly band crankcase heaters that must be energized 24 hours before starting compressor. Power to the unit will energize the heaters. Heaters will be energized during the off-cycle as long as the unit has power. Failure to perform these pre-start instructions could result in compressor damage.

1. Verify compressor crank case heaters have been on for at least 24 hours.

2. Make sure all service valves are open.
3. Attach a thermocouple type temperature sensor on liquid line close to liquid line service valve. To ensure an accurate reading, clean line where sensor is attached. After securing sensor to line, insulate sensor and line to isolate it from ambient air.
4. Attach service gauges to suction and discharge ports.
5. Check low side pressure. Low pressure cutout opens below, and closes above, values in [Table 36, p. 56](#). If the low side pressure is less than the open psig, refrigerant may need to be added to the suction line before starting the compressor(s) to close the switch. SLOWLY meter into the suction line only as much R-410A as needed to close the low pressure cutout. Use the VAPOR charging connection. If possible, plan to use this entire refrigerant bottle on the same unit in order to minimize fractionalization. Use an accurate scale to measure and record amount of R-410A added.
6. Switch the field supplied unit disconnect “OFF”. Open the unit control box and plug in the reset relay for only the circuit being started.

⚠ WARNING

Hazardous Voltage!

Disconnect all electric power, including remote disconnects before servicing. Follow proper lockout/tagout procedures to ensure the power can not be inadvertently energized. Failure to disconnect power before servicing could result in death or serious injury.

7. Turn 115 volt control circuit switch “ON”. Close control box and switch field supplied unit disconnect “ON”. Unit power should be off no longer than 60 minutes to prevent refrigerant migration to compressor sumps. If power is off for longer than 60 minutes, allow time for crankcase heaters to drive refrigerant from compressor sumps before starting compressors.
8. Adjust setpoints at the HI.

Note: Sufficient cooling load must be visible to refrigerant circuit controls for mechanical refrigeration to operate. If necessary, temporarily reduce the discharge air setpoint to verify the refrigeration cycle operation.

9. Check voltage at all compressor terminals to ensure it is within 10% of nameplate voltage.
10. Check voltage imbalance from these three voltage readings at each compressor. Maximum allowable voltage imbalance, phase to phase is 2%.
11. Start the first step compressor only.
12. Check amp draw at compressor terminals. RLA and LRA are on the unit nameplate.
13. Measure amp draw at evaporator fan motor terminals. FLA data is on the motor nameplate.

Start-Up

14. As soon as a compressor starts, verify correct rotation. If a scroll compressor is allowed to run backwards for even a very short period of time, internal compressor damage could occur and compressor life could be reduced. When rotating backwards scroll compressors make a loud noise, do not pump, and draw about 1/2 expected amps, and low side shell gets hot. Immediately shut off a compressor rotating backwards and correct wiring.

NOTICE:

Compressor Damage!

Improper power phasing could cause the compressor to run backward. Compressor could be running backward if it is noisy, low side shell gets hot, suction pressure does not drop within 5 seconds after startup and compressor only draws half of the expected amps. Stop the compressor immediately and have a qualified electrician or technician properly trained in 3-phase power correct the wiring. Failure to do the above could result in compressor damage.

15. **Air Cooled Only:** Check condenser fans for proper rotation. From top of unit, correct rotation direction is clockwise. If running backwards, correct wiring.

⚠ WARNING

Rotating Components!

During installation, testing, servicing and troubleshooting of this product it may be necessary to work with live and exposed rotating components. Have a qualified or licensed service individual who has been properly trained in handling exposed rotating components, perform these tasks. Failure to follow all safety precautions could result in rotating components cutting and slashing technician which could result in death or serious injury.

16. After 10 minutes, start second compressor of manifold circuits.
17. Allow 10 minutes for circuit operation to stabilize at full load.
18. Complete charging, if required.

Final Refrigerant Charge

If full charge was not used during installation, follow these steps:

- Determine remaining charge required by subtracting charge added during "Preliminary Refrigerant Charging," p. 35 from the total.
- With all circuit compressors running, SLOWLY meter remaining R-410A into the suction line from the LIQUID charging connection.

NOTICE:

Compressor Damage!

Do not overcharge system. Excessive refrigerant charging can cause compressor liquid slugging at startup and compressor (and/or condenser fans short cycle). Overcharging could result in compressor failure or reduced compressor life.

NOTICE:

Compressor Damage!

Avoid compressor liquid slugging. Only add liquid in the suction line when the compressor is running. Use extreme caution to meter liquid refrigerant in to the suction line slowly. If liquid is added too rapidly, compressor oil dilution and oil pump out could occur. Failure to follow the above could result in compressor failure or reduced compressor life.

- Use an accurate scale to measure and record amount of R-410A added.
- After unit has been operating for approximately 30 minutes at full load, measure and record operating pressures.
 - Air Cooled Only:** Operating pressure measurement must be made with all condenser fans running.

Repeat for other circuits.

Start-up Procedure

Using the startup log on the following pages, establish nominal conditions for consistent measurements as follows:

- Leaving air greater than 60°F
- Entering air temperature = 70 to 90°F
- Entering water temperature > 60°F

With all compressors running at full load:

- Compute superheat from the suction line pressure and temperature at the compressor on each circuit. Adjust the thermal expansion valve settings if necessary. Superheat should be between 14 and 20°F.
- Inspect refrigerant flow in the liquid line sight glass. Flow should be smooth and even, with no bubbles once the system has stabilized.

Note: Sight glass moisture indicator may show caution or wet at start-up. May need up to 12 hours of operation for system to reach equilibrium and correctly show moisture.

Normal startup will occur provided that Tracer Summit is not controlling the module outputs or the generic BAS is not keeping the unit off. To prevent Tracer Summit from affecting unit operation, remove Tracer wiring and make required changes to setpoint and sensor sources.

Operating & Programming Instructions

See IntelliPak™ Self-Contained Programming Guide, PKG-SVP01B-EN, for available unit operating setpoints and

instructions. A copy ships with each unit. For units with VFD option, see installer guide that ships with each VFD.

Startup Log

Complete this log at unit startup.

Unit: _____ **Unit Location:** _____

Unit Voltage: _____

A

B

C

Evaporator:

evaporator fan motor horsepower: _____ evaporator fan motor amps: _____

A

B

C

evaporator fan rpm (actual): _____

evaporator system static (from test and balance report or actual readings):

supply duct static: _____

return duct static: _____

evaporator air conditions with both compressors operating:

entering:	leaving:
dry-bulb °F: _____	dry-bulb °F: _____
wet-bulb °F: _____	wet-bulb °F: _____

evaporator system cfm (test and balance sheet or actual tested): _____

Compressor Amp Draw:

circuit A: _____	circuit B: _____
A	A
B	B
C	C
circuit C: _____	circuit D: _____
A	A
B	B
C	C
circuit E: _____	circuit F: _____
A	A
B	B
C	C

suction pressure, psig:	circuit A: _____	circuit B: _____	circuit C: _____	circuit D: _____
	circuit E: _____	circuit F: _____		
discharge pressure, psig:	circuit A: _____	circuit B: _____	circuit C: _____	circuit D: _____
	circuit E: _____	circuit F: _____		
super heat °F:	circuit A: _____	circuit B: _____	circuit C: _____	circuit D: _____
	circuit E: _____	circuit F: _____		
liquid line pressure, psig:	circuit A: _____	circuit B: _____	circuit C: _____	circuit D: _____
	circuit E: _____	circuit F: _____		
sub cooling °F:	circuit A: _____	circuit B: _____	circuit C: _____	circuit D: _____
	circuit E: _____	circuit F: _____		

Water Cooled Units:

Circuit A:

entering water temperature °F: _____ leaving water temperature °F: _____

entering water pressure, psig: _____ leaving water pressure, psig: _____

Circuit B:

enter water temperature °F: _____ leaving water temperature °F: _____



Start-Up

entering water pressure, psig: _____

leaving water pressure, psig: _____

Circuit C:

entering water temperature °F: _____

leaving water temperature °F: _____

entering water pressure, psig: _____

leaving water pressure, psig: _____

Circuit D:

enter water temperature °F: _____

leaving water temperature °F: _____

entering water pressure - psig: _____

leaving water pressure, psig: _____

Circuit E:

enter water temperature °F: _____

leaving water temperature °F: _____

entering water pressure - psig: _____

leaving water pressure, psig: _____

Circuit F:

enter water temperature °F: _____

leaving water temperature °F: _____

entering water pressure - psig: _____

leaving water pressure, psig: _____

Air Cooled Units:

(data taken from outside condensing unit)

voltage: _____
 A B C

amp draw: _____
 A B C

entering air temperature °F: _____

leaving air temperature °F: _____

refrigerant pressures at condenser, psig: _____/_____

sub cooling at condenser °F: _____

Maintenance

Service Access

Access unit controls through the front, top left panel. The panel is secured with two quick-acting fasteners and an automatic latch, which require a screwdriver to remove.

Removable unit panels on the right-hand side provide access to compressors, fan, motor belts, extended grease line fittings, and drive side bearing. On the unit's left side, removable panels allow access to the expansion valves, filter driers, refrigerant sight glasses, liquid line valves, opposite drive fan bearing, extended grease line fittings, condensers, and waterside economizer control valve.

The compressor, condenser, and fan motor access panels are secured with quick-acting fasteners. Fast thread screws secure access panels for economizer coils, evaporator coils, expansion valves, water valves, and left fan bearing. Access to other components requires removal of semipermanent panels secured with sheet metal screws. During operation, sight glasses are viewable through the portholes on the unit's left upper panel.

Variable Frequency Drive (VFD)

⚠ WARNING

Hazardous Voltage w/Capacitors!

Disconnect all electric power, including remote disconnects and discharge all motor start/run capacitors before servicing. Follow proper lockout/tagout procedures to ensure the power cannot be inadvertently energized. For variable frequency drives or other energy storing components provided by Trane or others, refer to the appropriate manufacturer's literature for allowable waiting periods for discharge of capacitors. Verify with an appropriate voltmeter that all capacitors have discharged. Failure to disconnect power and discharge capacitors before servicing could result in death or serious injury.

For additional information regarding the safe discharge of capacitors, see PROD-SVB06A-EN

The VFD access panel is hinged to allow service access to the fan motor and belt drive components that are located behind it. To swing the panel open:

- Remove the unit center cover panel to the left of the VFD panel.
- Remove and discard the sheet metal shipping screws along the top and bottom edges of the VFD panel.
- Disconnect the communications cable from the keypad on the VFD door panel.
- Turn the two slotted-head fasteners on the right edge of the VFD panel fully counterclockwise.
- Pull on the handle to swing the panel 180°.

To close and reattach the panel, reverse the procedures listed above.

Note: To secure the panel in the open position during service procedures, attach the chain mounted to the cabinet frame behind the unit center cover panel to the chain retainer notch on the edge of the VFD panel.

Note: Verify that all wires are in their proper position and not rubbing before replacing the panel.

Note: Panel weight rating = 225 lbs. total, including factory-installed components.

Air Filters

⚠ WARNING

Hazardous Voltage w/Capacitors!

Disconnect all electric power, including remote disconnects and discharge all motor start/run capacitors before servicing. Follow proper lockout/tagout procedures to ensure the power cannot be inadvertently energized. For variable frequency drives or other energy storing components provided by Trane or others, refer to the appropriate manufacturer's literature for allowable waiting periods for discharge of capacitors. Verify with an appropriate voltmeter that all capacitors have discharged. Failure to disconnect power and discharge capacitors before servicing could result in death or serious injury.

For additional information regarding the safe discharge of capacitors, see PROD-SVB06A-EN

Filter access doors are on the unit's left side. Filter access for the 2" filter rack on optional steam and hot water coils and airside economizers is also on the left side of the unit. To replace throwaway filters, remove the dirty elements and install new filters with the filter's directional arrows pointing toward the fan. Verify that no air bypasses the filters. See [Figure 42, p. 80](#) and [Figure 43, p. 80](#) for proper filter placement.

Figure 42. Unit filter sizes and placement for SXWF 20-38 tons or SXRF 20-35 tons

Without steam or hot water coil

18 x 20	18 x 20	18 x 20	18 x 20
20 x 20	20 x 20	20 x 20	20 x 20
18 x 20	18 x 20	18 x 20	18 x 20

With steam or hot water coil

16 x 20	16 x 20	16 x 20	16 x 20
20 x 20	20 x 20	20 x 20	20 x 20
18 x 20	18 x 20	18 x 20	18 x 20

Note: All filters are 2". These views are from the back of the unit (L-R).

Figure 43. Unit filter sizes and placement for SXWF 42-80 tons or SXRF 40-60 tons

Without hot water or steam coil

25 x 20	25 x 20	25 x 20	25 x 20	25 x 20	25 x 20
20 x 20	20 x 20	20 x 20	20 x 20	20 x 20	20 x 20
25 x 20	25 x 20	25 x 20	25 x 20	25 x 20	25 x 20

With hot water or steam coil

25 x 20	25 x 16	25 x 16	25 x 16	25 x 16	25 x 20
20 x 20	20 x 16	20 x 16	20 x 16	20 x 16	20 x 20
25 x 20	25 x 16	25 x 16	25 x 16	25 x 16	25 x 20

Note: All filters are 2". These views are from the back of the unit (L-R).

Figure 44. Unit filter sizes and placement for SXWF 90-110 tons

Without steam or hot water coil

24 x 24	24 x 24	24 x 24	24 x 24	24 x 24	24 x 12
24 x 24	24 x 24	24 x 24	24 x 24	24 x 24	24 x 12
24 x 24	24 x 24	24 x 24	24 x 24	24 x 24	24 x 12

Note: All filters are 2". These views are from the back of the unit (L-R).

Inspecting and Cleaning the Drain Pan

Check the condensate drain pan and drain line to ensure that the condensate drains properly at least every six months or as dictated by operating experience.

If evidence of standing water or condensate overflow exists, take steps to identify and remedy the cause immediately. Refer to the trouble shooting section of this manual for possible causes and solutions.

⚠ WARNING

Hazardous Voltage w/Capacitors!

Disconnect all electric power, including remote disconnects and discharge all motor start/run capacitors before servicing. Follow proper lockout/tagout procedures to ensure the power cannot be inadvertently energized. For variable frequency drives or other energy storing components provided by Trane or others, refer to the appropriate manufacturer's literature for allowable waiting periods for discharge of capacitors. Verify with an appropriate voltmeter that all capacitors have discharged. Failure to disconnect power and discharge capacitors before servicing could result in death or serious injury.

For additional information regarding the safe discharge of capacitors, see PROD-SVB06A-EN

Clean drain pans using the following procedure:

1. Disconnect all electrical power to the unit.
2. Don the appropriate personal protective equipment (PPE).
3. Remove all standing water.
4. Use a scraper or other tools to remove and solid matter. Remove solid matter with a vacuum device that utilizes high efficiency particulate arrestance (HEPA) filters with a minimum efficiency of 99.97% at 0.3 micron particle size.
5. Thoroughly clean the contaminated area(s) with a mild bleach and water solution or an EPA-approved sanitizer

specifically designed for HVAC use. Carefully follow the sanitizer manufacturer's instructions regarding product use.

6. Immediately rinse the drain pan thoroughly with fresh water to prevent potential corrosion from the cleaning solution.
7. Allow the unit to dry thoroughly before putting the system back into service.
8. Properly dispose of all contaminated materials and cleaning solution.

Inspecting and Cleaning the Fan

⚠ WARNING

Hazardous Voltage!

Disconnect all electric power, including remote disconnects before servicing. Follow proper lockout/tagout procedures to ensure the power can not be inadvertently energized. Failure to disconnect power before servicing could result in death or serious injury.

Inspect the fan section every six months or more frequently if operating experience dictates. Clean accumulated dirt and organic matter on the fan interior surfaces following the procedure below:

1. Disconnect all electrical power to the unit.
2. Wear the appropriate personal protective equipment (PPE).
3. Use a portable vacuum with HEPA filtration to remove the loose dirt and organic matter. The filter should be 99.97% efficient at 0.3 micron particle size.
4. Thoroughly clean the fan and associated components with an industrial cleaning solution. Carefully follow the cleaning solution manufacturer's instructions regarding personal protection and ventilation when using their product.
5. Rinse the affected surfaces thoroughly with fresh water and a fresh sponge to prevent potential corrosion of metal surfaces.
6. Allow the unit to dry completely before putting it back into service.
7. Properly dispose of all contaminated materials and cleaning solution.

Supply Fan

Important: *On units ordered with a Design Special of Inlet Guide Vanes, refer to non-current IOM (SCXF-SVX01D-EN) dated on or before March 2008 for maintenance procedure.*

Fan Drive

Perform the following procedures according to the "Periodic Maintenance Check List."

⚠ WARNING

Hazardous Voltage w/Capacitors!

Disconnect all electric power, including remote disconnects and discharge all motor start/run capacitors before servicing. Follow proper lockout/tagout procedures to ensure the power cannot be inadvertently energized. For variable frequency drives or other energy storing components provided by Trane or others, refer to the appropriate manufacturer's literature for allowable waiting periods for discharge of capacitors. Verify with an appropriate voltmeter that all capacitors have discharged. Failure to disconnect power and discharge capacitors before servicing could result in death or serious injury.

For additional information regarding the safe discharge of capacitors, see PROD-SVB06A-EN

1. Rotate the fan wheel to ensure it turns freely in the proper direction and is not rubbing on the fan housing or inlet. If necessary, center the fan wheel again.
2. Check the position of both shafts. Fan and motor shafts should operate parallel to each other for maximum belt and bearing life. Shim as necessary under the motor or fan bearings to obtain proper alignment.
3. Check the fan motor sheave alignment with straight edge or a tightly pulled string. For sheaves of different widths, place a string in the center groove of each sheave and pull it tight for a center line. See [Figure 46, p. 83](#) for recommended torques.
4. Once the sheaves are properly aligned, tighten sheave set screws to proper torque.
5. Check belt tension. Refer to the "Measuring Belt Tension" section.
6. If required, adjust belt to the minimum recommended tension. Refer to "Adjusting Belt Tension" section.
7. Retighten bearing set screws to the proper torques after aligning the sheaves. See [Table 47, p. 82](#) for proper torques.
8. Check the fan bearing locking collars for tightness on the shaft. To tighten the locking collar, loosen the set screw and slide the collar into its proper position over the extended end of the inner case. Tighten the set screw to the torque value in [Table 47, p. 82](#).
9. During air balancing, verify the sheave alignment, belt tension, and that the shaft is parallel.

Figure 45. Fan shaft and motor sheave alignment

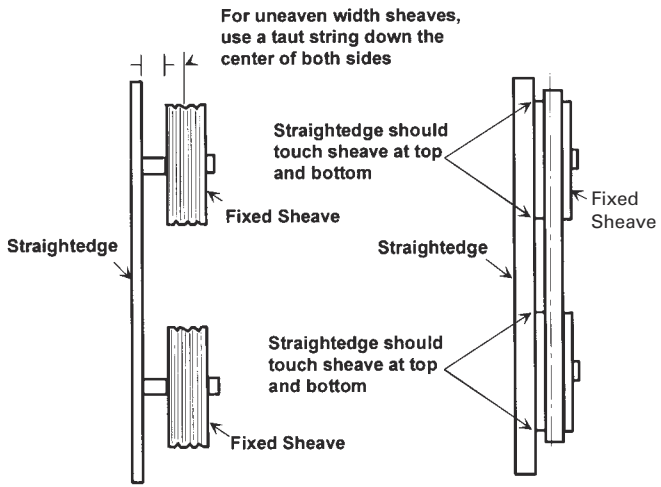

1. Measure belt span between centers of sheaves and set the large "O" ring of the tensioning gauge at 1/64 inch for each inch of belt span.
2. Set the load "O" ring at zero.
3. Place the large end of the gauge at the center of the belt span. Press down until the large "O" ring is even with the top of the belt line or the next belt as in [Figure 46, p. 83](#). Place a straight edge across the sheaves as a reference point. See [Figure 45, p. 82](#).
4. Remove the gauge. Note that the load "O" ring now indicates a number on the plunger scale. This number represents pounds of force required to deflect the belt.

Fan Bearings

The opposite drive end bearing is a special bearing with close tolerance fit of balls and races. Replace this bearing with the same part number as the original bearing.

NOTICE:

Bearing Failure!
 Do not mix greases with different bases within the bearing. Mixing grease within the bearing could result in premature bearing failure.

Table 46. Compatible fan bearing grease

Recommended Grease	Recommended Operating Range
Exxon Unirex #2	-20°F to 205°F
Mobile 532	
Mobile SHC #220	
Texaco Premium	

Fan Belt Tension

Note: Check fan belt tension at least twice during the first days of new belt operation since there is a rapid decrease in tension until belts are run-in.

Proper belt tension is necessary to endure maximum bearing and drive component life and is based on fan brake horsepower requirements. If frayed or worn, replace belts in matched sets.

Measuring Belt Tension

Measure fan belt tension with a Browning, Gates, or equivalent belt tension gauge. Determine deflection by dividing the belt span distance (in inches) by 64. See [Figure 46, p. 83](#). Follow the procedure below to measure belt tension.

Table 47. Fan hub and sheave torques

Unit size	Fan Dia.	Set Screw Size	Torque (ft-lbs)
SCWF 20	18"	5/16"	12
SCWF 22			
SCWF 25			
SCRF 20	18"	5/16"	12
SCWF 29			
SCWF 32			
SCRF 25			
SCRF 30			
SCWF 35			
SCWF 38	20"	5/16"	14
SCRF 30			
SCRF 35			
SCWF 42	25"	3/8"	24
SCWF 46			
SCWF 52			
SCWF 58			
SCRF 40			
SCRF 50			
SCWF 65			
SCWF 72	27"	3/8"	24
SCWF 80			
SCRF 60			
SCWF 90			
SCWF C0			
SCWF C1			

Adjusting Belt Tension

NOTICE:

Belt Tension!

Do not over-tension belts. Excessive belt tension will reduce fan and motor bearing life, accelerate belt wear and possibly cause shaft failure.

Figure 46. Belt tension gauge (top) and fan belt adjustment (bottom)

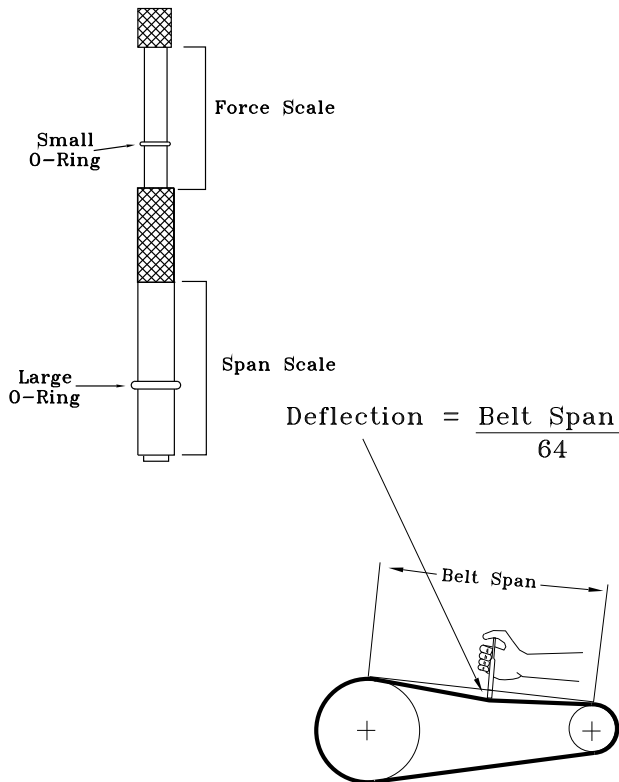

To adjust belt tension see [Figure 46, p. 83](#) and perform the following procedure:

1. Loosen bolts A, B, and E on both sides of the sliding motor base. See [Figure 47, p. 83](#).
2. Loosen nuts C and D (as required for motor horsepower) to slide the motor on its mounting plate in the proper direction to tension or relieve tension on the belt.
3. Adjust nuts A-D and bolt E. Do not stretch the belts over the sheaves.
4. Retighten all nuts and bolts.
5. Verify tension is adjusted properly.

Recommended belt tension range values are on the unit fan scroll. To access the fan scroll, face the right-hand side of the unit and remove the top left panel. The belt tension label is on the top right-hand corner of the fan scroll. See [Figure 47, p. 83](#) and [Figure 48, p. 84](#).

The correct operation tension for a V-belt drive is the lowest tension at which the belt will not slip under the peak load conditions. It may be necessary to increase the tension of some drives to reduce flopping or excessive startup squealing.

Figure 47. Location of fan belt label on fan scroll (top) and belt tensioning with fan adjustment points (bottom)

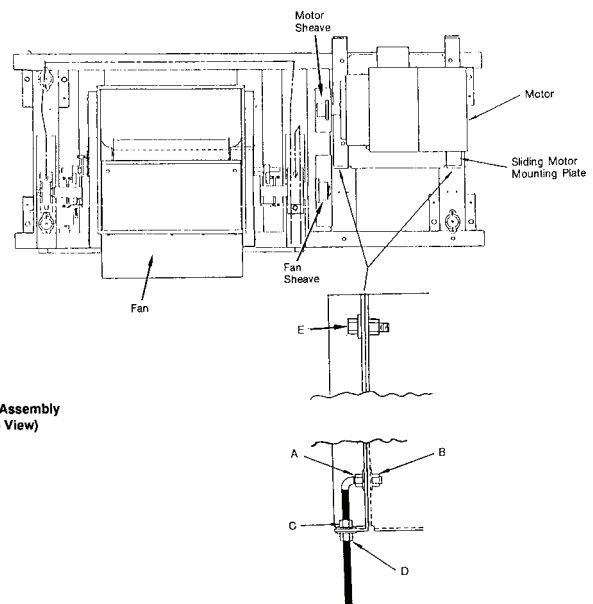
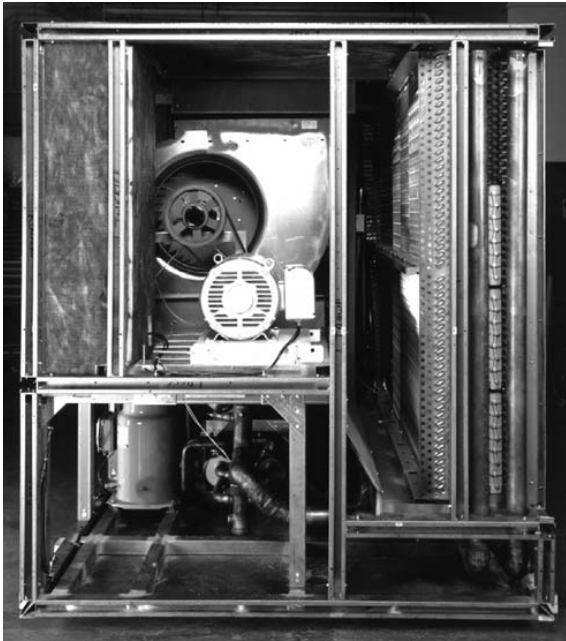

Figure 48. Right-side view of the self contained unit

Compressors

Scroll Compressor Failure Diagnosis and Replacement

If compressor failure is suspected, refer to COM-SVN01A-EN for detailed information regarding compressor failure diagnosis and replacement of scroll compressors.

Important: Should compressor replacement of a manifold set be required **DO NOT** alter manifold piping. The design is critical to proper refrigerant flow.

40 Ton Air-Cooled Compressor Suction Restrictor Replacement

The 40T air-cooled unit has a manifold compressor set on one circuit. A restrictor in the 10 ton compressor suction connection balances refrigerant flow. Instructions below are for installation if compressor replacement is required.

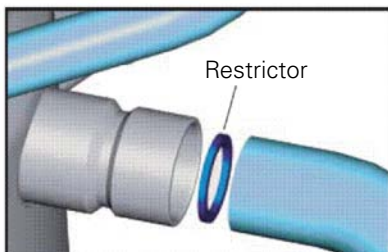
Figure 49. Restrictor installation

Refrigerant System

Should refrigerant system repair be required, Leak Test, Brazing and Evacuation Procedures are described.

Preliminary Charging is described in the Installation-Mechanical section, "Preliminary Refrigerant Charging," p. 35 and Final Charging is described in Start-up section, "Final Refrigerant Charge," p. 76.

Ignore *Air Cooled Only* steps for Water Cooled systems.

Refrigerant systems that have been opened must have filter driers replaced and complete leak test and evacuation before recharging.

Refrigerant Leak Test Procedure

⚠ WARNING

Confined Space Hazards!

Do not work in confined spaces where refrigerant or other hazardous, toxic or flammable gas may be leaking. Refrigerant or other gases could displace available oxygen to breathe, causing possible asphyxiation or other serious health risks. Some gases may be flammable and or explosive. If a leak in such spaces is detected, evacuate the area immediately and contact the proper rescue or response authority. Failure to take appropriate precautions or to react properly to such potential hazards could result in death or serious injury.

⚠ WARNING

Hazard of Explosion!

Never use an open flame to detect gas leaks. It could result in an explosion. Use a leak test solution for leak testing. Failure to follow recommended safe leak test procedures could result in death or serious injury or equipment or property-only-damage.

⚠ WARNING

Hazard of Explosion!

Use only dry nitrogen with a pressure regulator for pressurizing unit. Do not use acetylene, oxygen or compressed air or mixtures containing them for pressure testing. Do not use mixtures of a hydrogen containing refrigerant and air above atmospheric pressure for pressure testing as they may become flammable and could result in an explosion. Refrigerant, when used as a trace gas should only be mixed with dry nitrogen for pressurizing units. Failure to follow these recommendations could result in death or serious injury or equipment or property-only damage.

⚠ WARNING**Hazardous of Explosion!**

Do not exceed unit nameplate design pressures when leak testing system. Failure to follow these instructions could result in an explosion causing death or serious injury.

⚠ WARNING**R-410A Refrigerant under High Pressure!**

The units described in this manual use R-410A refrigerant. Use ONLY R-410A rated service equipment or components with these units. For specific handling concerns with R-410A, please contact your local Trane representative. Failure to use R-410A rated service equipment or components could result in equipment exploding under R-410A high pressures which could result in death, serious injury, or equipment damage.

Note: These service procedures require working with refrigerant. Do not release refrigerant to the atmosphere! The service technician must comply with all federal, state, and local laws.

When Leak-testing refrigerant systems, observe all safety precautions

Leak test only one circuit at a time to minimize system exposure to potentially harmful moisture in the air.

Field Piping (air cooled discharge and liquid lines)

1. Ensure all required field installed piping pressure tests are completed in accordance with national and/or local codes.
2. Close liquid line angle valve.
3. Connect R-410A refrigerant cylinder to high side charging port (at Remote Condenser or field supplied discharge line access port). Add refrigerant to reach pressure of 12 to 15 psig.
4. Disconnect refrigerant cylinder. Connect dry nitrogen cylinder to high side charging port and increase pressure to 150 psig. Do not exceed high side (discharge) unit nameplate design pressure. Do not subject low side (suction) components to high side pressure.
5. Check all piping joints, valves, etc. for leaks. Recommend using electronic detector capable of measuring 0.1 oz/year leak rate.
6. If a leak is located, use proper procedures to remove the refrigerant/nitrogen mixture, break connections and make repairs. Retest for leaks.
7. Make sure all service valves are open.

System Repair

1. If system is water cooled with service valves, or air cooled, high and low side may be tested independently by closing liquid line angle valve and water cooled unit discharge line ball valve. Otherwise leave all valves open and DO NOT exceed low side design pressure.
2. Connect R-410A refrigerant cylinder to charging port, add refrigerant to reach pressure of 12 to 15 psig.
3. Disconnect refrigerant cylinder. Connect dry nitrogen cylinder to high side charging port and increase pressure to 150 psig. DO NOT exceed unit nameplate design pressures. If testing complete system, low side design pressure is maximum.
4. Check piping and/or components as appropriate for leaks.
5. Recommend using electronic detector capable of measuring 0.1 oz/year leak rate.
6. If a leak is located, use proper procedures to remove the refrigerant/nitrogen mixture, break connections and make repairs. Retest for leaks.
7. Make sure all service valves are open.

Brazing Procedures**⚠ WARNING****Hazard of Explosion and Deadly Gases!**

Never solder, braze or weld on refrigerant lines or any unit components that are above atmospheric pressure or where refrigerant may be present. Always remove refrigerant by following the guidelines established by the EPA Federal Clean Air Act or other state or local codes as appropriate. After refrigerant removal, use dry nitrogen to bring system back to atmospheric pressure before opening system for repairs. Mixtures of refrigerants and air under pressure may become combustible in the presence of an ignition source leading to an explosion. Excessive heat from soldering, brazing or welding with refrigerant vapors present can form highly toxic gases and extremely corrosive acids. Failure to follow all proper safe refrigerant handling practices could result in death or serious injury.

Proper brazing techniques are essential when installing refrigerant piping. The following factors should be kept in mind when forming sweat connections.

1. When heating copper in the presence of air, copper oxide forms. To prevent copper oxide from forming inside the tubing during brazing, sweep an inert gas, such as dry nitrogen, through the tubing. A nitrogen flow of 1 to 3 cubic feet per minute is sufficient to displace the air in the tubing and prevent oxidation of the interior surfaces. Use a pressure regulating valve or flow meter to control the flow.
2. Ensure that the tubing surfaces requiring brazing are clean, and that the tube ends are carefully reamed to remove any burrs.

Maintenance

3. Make sure the inner and outer tubes of the joint are symmetrical and have a close clearance, providing an easy 'slip' fit. If the joint is too loose, the connection's tensile strength is significantly reduced. Ensure the overlap distance is equal to the inner tube diameter.
4. Wrap each refrigerant line component with a wet cloth to keep it cool during brazing. Excessive heat can damage the internal components.

Note: Use 40-45% silver brazing alloy (BAg-7 or BAg-28) on dissimilar metals. Use BCup-6 brazing alloy on copper-to-copper joints.

NOTICE:

Valve Damage!

Remove, do not wrap, water cooled condenser pressure relief valves during brazing. Failure to do so could result in valve damage.

5. If using flux, apply it sparingly to the joint. Excess flux will contaminate the refrigerant system.
6. Apply heat evenly over the length and circumference of the joint.
7. Begin brazing when the joint is hot enough to melt the brazing rod. The hot copper tubing, not the flame, should melt the rod.
8. Continue to apply heat evenly around the joint circumference until the brazing material is drawn into the joint by capillary action, making a mechanically sound and gas-tight connection.
9. Visually inspect the connection after brazing to locate any pinholes or crevices in the joint. Use a mirror if joint locations are difficult to see.

System Evacuation Procedures

Each refrigeration circuit must be evacuated before the unit can be charged and started.

Use a rotary type vacuum pump capable of pulling a vacuum of 100 microns or less.

Verify that the unit disconnect switch and the system control circuit switches are "OFF".

Oil in the vacuum pump should be changed each time the pump is used with high quality vacuum pump oil. Before using any oil, check the oil container for discoloration which usually indicates moisture in the oil and/or water droplets. Moisture in the oil adds to what the pump has to remove from the system, making the pump inefficient.

When connecting vacuum pump to refrigeration system, it is important to manifold vacuum pump to both high and low side of system (liquid line access valve and suction line access valve). Follow pump manufacturer's directions for proper methods of using vacuum pump.

Lines used to connect the pump to the system should be copper and of the largest diameter that can practically be used. Using larger line sizes with minimum flow resistance can significantly reduce evacuation time.

Note: Rubber or synthetic hoses are not recommended for system evacuation. They have moisture absorbing characteristics which result in excessive rates of evaporation, causing pressure rise during standing vacuum test. This makes it impossible to determine if system has a leak, excessive residual moisture, or continual or high rate of pressure increase due to hoses.

An electronic micron vacuum gauge should be installed in the common line ahead of the vacuum pump shutoff valve, as shown in Figure 50, p. 87. Close Valves B and C, and open Valve A.

Start vacuum pump. After several minutes the gauge reading will indicate the maximum vacuum the pump is capable of pulling. Rotary pumps should produce vacuums of 100 microns or less.

NOTICE:

Motor Winding Damage!

Do not use a megohm meter or apply voltage to a compressor motor winding while it is under a vacuum. Voltage sparkover could cause damage to the motor windings.

Open Valves B and C. Evacuate system to a pressure of 300 microns or less. As vacuum is being pulled on system, there could be a time when it would appear that no further vacuum is being obtained, yet pressure is high. It is recommended that during evacuation process, vacuum be "Broken", to facilitate the evacuation process.

To break the vacuum, shut valves A, B, & C and connect a refrigerant cylinder to charging port on manifold. Purge air from hose. Raise standing vacuum pressure in system to "zero" (0 psig) gauge pressure. Repeat process two or three times during evacuation.

Note: It is unlawful to release refrigerant into the atmosphere. When service procedures require working with refrigerants, the service technician must comply with all Federal, State, and local laws.

Standing Vacuum Test . Once 300 microns or less is obtained, close Valve A and leave valves B and C open to allow the vacuum gauge to read the actual system pressure. Let system equalize for approximately 15 minutes. This is referred to as a "standing vacuum test" where, time versus pressure rise. Maximum allowable rise over a 15 minute period is 200 microns. If pressure rise is greater than 200 microns but levels off to a constant value, excessive moisture is present. If pressure steadily continues to rise, a leak is indicated. Figure 51 illustrates three possible results of "standing vacuum test".

If a leak is encountered, repair the system and repeat the evacuation process until the recommended vacuum is obtained. Once the system has been evacuated, break the

vacuum with refrigerant and complete the remaining Pre-Start procedures before starting the unit.

Figure 50. Typical vacuum pump hookup

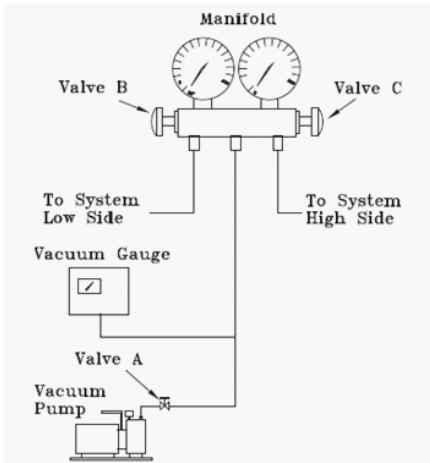
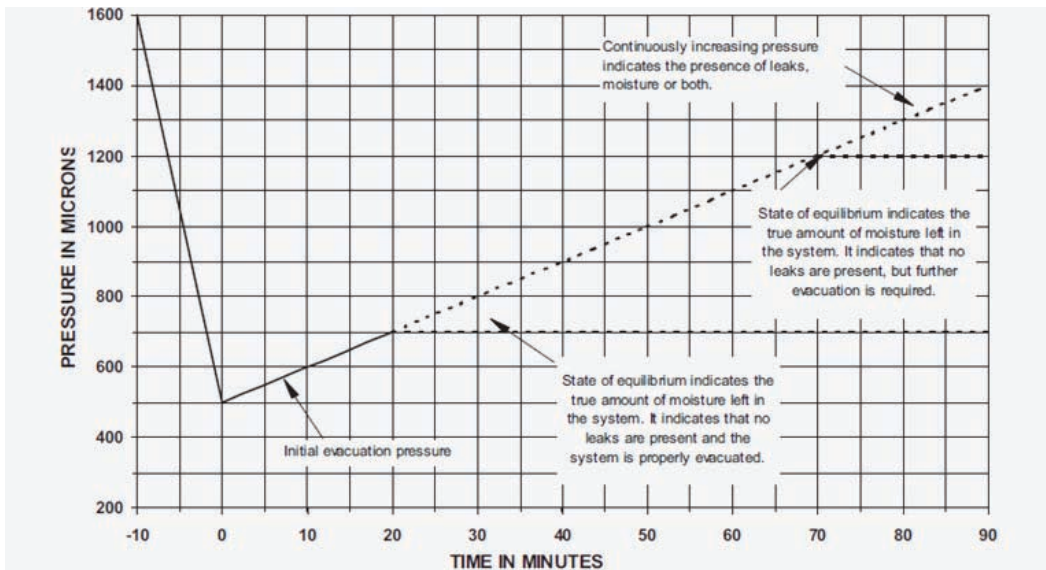
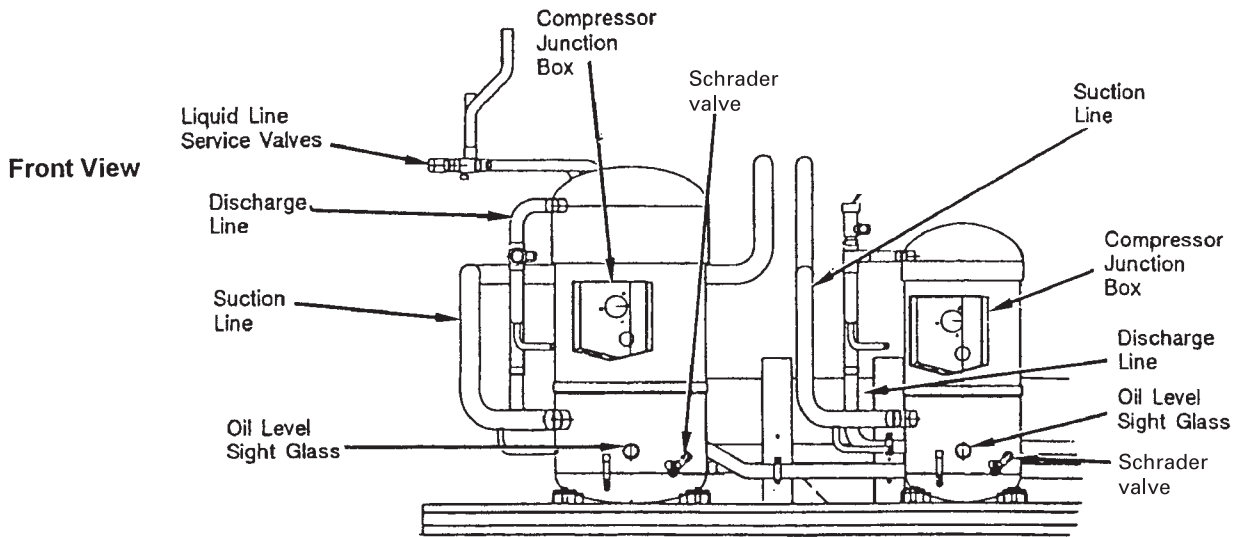

Figure 51. Evacuation time vs. pressure rise



Components

Figure 52. Typical water-cooled (SXWF) compressor section components



Top View

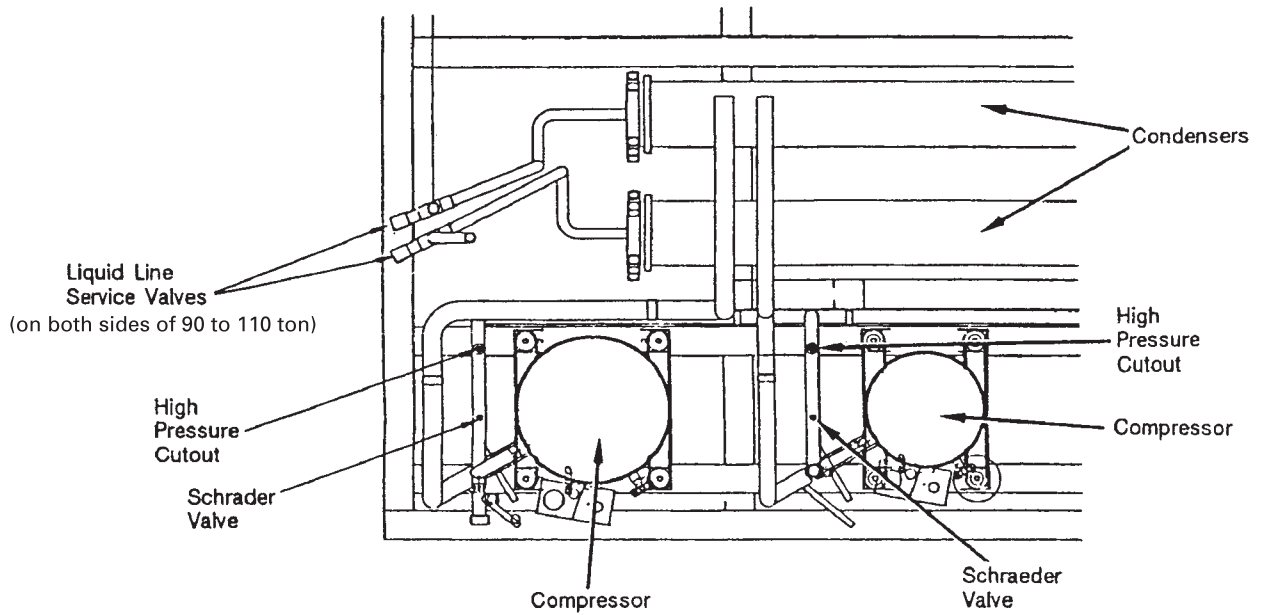

Coil Fin Cleaning

⚠ WARNING

Hazardous Chemicals!

Coil cleaning agents can be either acidic or highly alkaline and can burn severely if contact with skin occurs. Handle chemical carefully and avoid contact with skin. **ALWAYS** wear Personal Protective Equipment (PPE) including goggles or face shield, chemical resistant gloves, boots, apron or suit as required. For personal safety refer to the cleaning agent manufacturer's Materials Safety Data Sheet and follow all recommended safe handling practices. Failure to follow all safety instructions could result in death or serious injury.

⚠ WARNING

Hazardous Voltage w/Capacitors!

Disconnect all electric power, including remote disconnects and discharge all motor start/run capacitors before servicing. Follow proper lockout/tagout procedures to ensure the power cannot be inadvertently energized. For variable frequency drives or other energy storing components provided by Trane or others, refer to the appropriate manufacturer's literature for allowable waiting periods for discharge of capacitors. Verify with an appropriate voltmeter that all capacitors have discharged. Failure to disconnect power and discharge capacitors before servicing could result in death or serious injury.

For additional information regarding the safe discharge of capacitors, see PROD-SVB06A-EN

NOTICE:

Equipment Damage!

Do not clean the refrigerant coil with hot water or steam. The use of hot water or steam as a refrigerant coil-cleaner agent could cause high pressure inside the coil tubing and subsequent damage to the coil. Do not use acidic chemical coil cleaners. Also, do not use alkaline chemical coil cleaners with a pH value greater than 8.5 (after mixing) without using an aluminum corrosion inhibitor in the cleaning solution. Use of the chemical could result in equipment damage.

Keep coils clean to maintain maximum performance. For operation at its highest efficiency, clean the refrigerant coil often during periods of high cooling demand or when dirty conditions prevail. Clean the coil a minimum of once per year to prevent dirt buildup in the coil fins, where it may not be visible.

Remove large debris from the coils and straighten fins before cleaning. Remove filters before cleaning.

Clean refrigerant coils with cold water and detergent, or with one of the commercially available chemical coil cleaners. Rinse coils thoroughly after cleaning.

Economizer and evaporator coils are installed so the evaporator is directly behind the economizer. To clean between the coils, remove the sheet metal block off. Access the block off by removing the corner panels on the unit's left or right rear side.

If the refrigerant coil is installed back to back with the waterside economizer coil, use a cleaner that is acceptable for cleaning both types of coils.

Inspecting and Cleaning Coils

Coils become externally fouled as a result of normal operation. Coil surface dirt reduces heat transfer ability and can cause comfort problems, increased airflow resistance and thus increased operating energy costs.

Inspect coils at least every six months or more frequently as dictated by operating experience. Cleaning frequently is dependent upon system operating hours, filter maintenance, efficiency, and dirt load. Following is the suggested method for cleaning steam and hot water coils.

Steam and Hot Water Coils

⚠ WARNING

Hazardous Voltage w/Capacitors!

Disconnect all electric power, including remote disconnects and discharge all motor start/run capacitors before servicing. Follow proper lockout/tagout procedures to ensure the power cannot be inadvertently energized. For variable frequency drives or other energy storing components provided by Trane or others, refer to the appropriate manufacturer's literature for allowable waiting periods for discharge of capacitors. Verify with an appropriate voltmeter that all capacitors have discharged. Failure to disconnect power and discharge capacitors before servicing could result in death or serious injury.

For additional information regarding the safe discharge of capacitors, see PROD-SVB06A-EN

1. Disconnect all electrical power to the unit.
2. Wear the appropriate personal protective equipment (PPE).
3. Access both sides of the coil section.
4. Use a soft brush to remove loose debris from both sides of the coil.
5. Use a steam cleaning machine, starting from the top of the coil and working downward. Clean the leaving air side of the coil first, then the entering air side. Use a block-off to prevent steam from blowing through the coil and into a dry section of the unit.
6. Repeat step 5 as necessary. Confirm that the drain line is open following completion of the cleaning process.
7. Allow the unit to dry thoroughly before putting the system back into service.
8. Straighten any coil fins that may be damaged with a fin rake.

Maintenance

9. Replace all panels and parts and restore electrical power to the unit.
10. Ensure that contaminated material does not contact other areas of the equipment or building. Properly dispose of all contaminated materials and cleaning solutions.

Refrigerant Coils

⚠ WARNING

Hazardous Voltage w/Capacitors!

Disconnect all electric power, including remote disconnects and discharge all motor start/run capacitors before servicing. Follow proper lockout/tagout procedures to ensure the power cannot be inadvertently energized. For variable frequency drives or other energy storing components provided by Trane or others, refer to the appropriate manufacturer's literature for allowable waiting periods for discharge of capacitors. Verify with an appropriate voltmeter that all capacitors have discharged. Failure to disconnect power and discharge capacitors before servicing could result in death or serious injury.

For additional information regarding the safe discharge of capacitors, see PROD-SVB06A-EN

1. Disconnect all electrical power to the unit.
2. Wear the appropriate personal protective equipment (PPE).
3. Access to the coil section of the unit (both sides).
4. Use a soft brush to remove loose debris from both sides of the coil.
5. Mix a high quality coil cleaning detergent with water according to the manufacturer's instructions. If the detergent is strongly alkaline after mixing (pH 8.5 or higher), it must contain an inhibitor. Carefully follow the cleaning solution manufacturer's instructions regarding product use.
6. Place the mixed solution in a garden pump-up sprayer or high pressure sprayer. If using a high pressure sprayer note the following:
 - Maintain a minimum nozzle spray angle of 15°
 - Spray perpendicular to the coil face
 - Protect other areas of the equipment and internal controls from contact with moisture or the cleaning solution
 - Keep the nozzle at least six inches from the coil
 - Do not exceed 600 psig

Draining the Waterside Economizer Coil

NOTICE:

Coil Freezeup!

Drain and vent coils when not in use. Trane recommends glycol protection in all possible freezing applications. Use a glycol approved for use with commercial cooling and heating systems and copper tube coils. Failure to do so could result in equipment damage.

Drain plugs are in the piping below each coil's supply and return header. Use these plugs to drain the coil and piping. When draining the coil, open the vents at the top of the supply and return headers. Also, a drain plug is at the bottom of the inlet condenser manifold and in the outlet pipe near the unit's left side. Remove these plugs to drain the condensers. Be sure to open the vent plugs at the top of the condenser inlet and outlet manifold. See [Figure 24, p. 32](#).

When refilling the condenser/waterside economizer coil system with water, provide adequate water treatment to prevent the formation of scale or corrosion.

Cleaning the Condenser

NOTICE:

Proper Water Treatment!

The use of untreated or improperly treated water in a CenTraVac could result in scaling, erosion, corrosion, algae or slime. It is recommended that the services of a qualified water treatment specialist be engaged to determine what water treatment, if any, is required. Trane assumes no responsibility for equipment failures which result from untreated or improperly treated water, or saline or brackish water.

Condensing water contains minerals that collect on the condenser tube walls. Cooling towers also collect dust and foreign materials that deposit in the condenser tube. The formation of scale or sludge in the condenser is indicated by a decreased water flow, low temperature difference between inlet and outlet water, and abnormally high condensing temperatures. To maintain maximum condenser efficiency, the condenser must remain free of built-up scale and sludge. Clean the condenser either mechanically or chemically.

Mechanical Cleaning of Condenser and Economizer Coils

1. Turn off the condenser supply water. Remove drain plugs discussed in the "Draining the Coil" section.
2. Remove the condenser head to expose the condenser tubes.
3. Rotate a round brush through the tubes to loosen contaminant.

4. Flush tubes with water to push the sludge out through the drain opening in the bottom of the supply header and the return pipe.
5. To clean the economizer tubes, remove the cast iron header plates at both sides of the coil between the inlet and outlet headers (four-row coils only; two-row coils do not have cover plates at right end). Rotate round brush through tubes from left end to loosen contaminants. Flush tubes with water.
6. Replace condenser end plates and clamps. The end plates must be centered when tightening the clamp.
7. Replace coil headers with gaskets and torque bolts to 50 ft.-lb.
8. Replace drain and vent plugs.

Chemical Cleaning of Condenser and Economizer Coil

Chemical cleaning removes scale deposits built up by minerals in the water. For a suitable chemical solution, consult a water treatment specialist. The condenser water circuit is composed of copper, steel, and cast iron. The chemical supply house should approve or provide all materials used in the external circulating system, along with the quantity of cleaning material, duration of cleaning time, and safety precautions necessary for handling the cleaning agent.

Piping Components

Water Valves

⚠ WARNING

Hazardous Voltage w/Capacitors!

Disconnect all electric power, including remote disconnects and discharge all motor start/run capacitors before servicing. Follow proper lockout/tagout procedures to ensure the power cannot be inadvertently energized. For variable frequency drives or other energy storing components provided by Trane or others, refer to the appropriate manufacturer's literature for allowable waiting periods for discharge of capacitors. Verify with an appropriate voltmeter that all capacitors have discharged. Failure to disconnect power and discharge capacitors before servicing could result in death or serious injury.

For additional information regarding the safe discharge of capacitors, see PROD-SVB06A-EN

Water valves have a stern packing nut. If there is evidence of water leakage at the valve stem, proceed as follows:

1. Remove actuator motor from support plate.
2. Remove shaft coupling.
3. Torque the packing nut to 10-ft.-lbs. of torque.
4. Replace shaft coupling.
5. Replace actuator motor.

Flow Switch

Flow switches have a magnet on the vane assembly that attracts ferrous particulate may build up on the magnet to the point that the vane will wedge and not operate properly. When the flow switch does not operate, remove and replace.

Maintenance Periodic Checklists

⚠ WARNING

Hazardous Service Procedures!

The maintenance and troubleshooting procedures recommended in this manual could result in exposure to electrical, mechanical or other potential safety hazards. Always refer to the safety warnings provided throughout this manual concerning these procedures. Unless specified otherwise, disconnect all electrical power including remote disconnect and discharge all energy storing devices such as capacitors before servicing. Follow proper lockout/tagout procedures to ensure the power can not be inadvertently energized. When necessary to work with live electrical components, have a qualified licensed electrician or other individual who has been trained in handling live electrical components perform these tasks. Failure to follow all of the recommended safety warnings provided, could result in death or serious injury.

Monthly Checklist

The following check list provides the recommended maintenance schedule to keep the commercial self-contained equipment running efficiently.

1. Inspect unit air filters. Clean or replace if airflow is blocked or if filters are dirty.
2. Inspect coils for excess moisture or icing. Icing on the coils may indicate low airflow supply, restricted airflow from dirty fins, evaporator frost protection sensor problems, or a shortage of refrigerant flowing through the coil.
3. Check that condensate from the evaporator and economizer coils flows freely through the condensate piping, traps, drain pan, and drainage holes. Remove algae and or any airflow obstructions.
4. Check the condition and tension of fan belts. Adjust tension if belts are floppy or squeal continually. Replace worn or fraying belts in matched sets.

Note: *Check belt tension and adjust it at least twice daily the first days of new belt operation. Belt tension will rapidly decrease until the belts are run in.*

5. Check the liquid line sight glasses during operation. Bubbles in the sight glasses indicate a possible shortage of refrigerant or an obstruction in the liquid lines, e.g. dirty liquid line filter driers.
6. Inspect filter driers for leaks, flow obstructions, or temperature drop across the filter drier. A noticeable temperature differential, e.g. 5°F, in the liquid line may

Maintenance

indicate an obstruction. Replace the filter drier if it appears clogged.

7. Inspect the optional waterside economizer coil. Clean the coil to prevent airflow restrictions through the fins.
8. Check and record operating pressures.

Semi-Annual Maintenance

1. Verify the fan motor is properly lubricated. Follow lubrication recommendations on the motor tag or nameplate. Contact the motor manufacturer for more information.
2. Lubricate fan bearings. For best results, lubricate bearings during unit operation. Refer to [Table 46, p. 82](#) for recommended grease.

Note: *The bearings are manufactured using a special synthetic lithium-based grease designed for long life and minimum lube intervals. Over lubrication can be just as harmful as not enough.*

3. With power disconnected, manually rotate the fan wheel to check for obstructions in the housing or interference with fan blades. Remove obstructions and debris. Center the fan wheel if necessary.
4. Check the fan assembly sheave alignment. Tighten set screws to their proper torques.
5. Check water valves for leakage at valve stem packing nut.

Note: *Perform this procedure monthly if the unit is in a coastal or corrosive environment.*

Annual Maintenance

Check and tighten all set screws, bolts, locking collars and sheaves.

1. Inspect, clean, and tighten all electrical connections.
2. Visually inspect the entire unit casing for chips or corrosion. Remove rust or corrosion and repaint surfaces.
3. Visually check for leaks in refrigerant piping.
4. Inspect fan, motor, and control contacts. Replace badly worn or eroded contacts.
5. Inspect the thermal expansion valve sensing bulbs for cleanliness, good contact with the suction line, and adequate insulation from ambient air.
6. Verify the superheat setting is 12 -17°F at the compressor.

When checking operating pressures and conditions, establish the following nominal conditions for consistent measurements.

1. Leaving air temperature greater than 60°F
2. Entering air temperature is 80 - 90°F
3. Entering water temperature greater than 65°F
4. Compressors running at full load
5. Drain the condensing water system and inspect it thoroughly for fouling, clean condensers if necessary.

Diagnostics

Troubleshooting

System Checks

⚠ WARNING

Live Electrical Components!

During installation, testing, servicing and troubleshooting of this product, it may be necessary to work with live electrical components. Have a qualified licensed electrician or other individual who has been properly trained in handling live electrical components perform these tasks. Failure to follow all electrical safety precautions when exposed to live electrical components could result in death or serious injury.

Before proceeding with technical trouble charts or controls checkout, complete the following system analysis:

1. Measure actual supply voltage at the compressor and an motor terminals with the unit running. Voltage must be within the range listed on the motor nameplate. Phase imbalance must be less than 2.0%.
2. Check all wiring and connections to be sure that they are intact, secure and properly routed. The as wired system diagrams are provided in the unit control panel.
3. Check that all fuses are installed and properly sized.
4. Inspect air filters and coils to be sure that airflow to the unit is not restricted.
5. Check the zone thermostat settings.
6. Ensure that the fan is rotating in the proper direction. If phasing is wrong at the main power terminal block, the fan and compressors will not run correctly.
7. Inspect ductwork and duct connections for tightness.

Operating Procedures

Install pressure gauges on the discharge and suction line access valves. When the unit has stabilized (after operating approximately 15 minutes at full load), record suction and discharge pressures. System malfunctions such as low airflow, line restrictions, incorrect refrigerant charge, malfunctioning of expansion valves, damaged compressors, etc. will result in pressure variations which are outside the normal range.

Note: *If phasing at the main incoming power terminal is incorrect, switch two of the three incoming power leads. If a compressor has been replaced and the phase is changed at the compressor, it will run backwards and discharge pressure will be very low. To resolve incorrect compressor wire phasing, change phasing at the compressor.*

It is important that pressures be measured under stable and constant conditions in order for the readings to be useful.

Voltage Imbalance

Voltage imbalance on three-phase systems can cause motor overheating and premature failure. Maximum allowable imbalance is 2.0%, and the readings used to determine it must be measured at the compressor terminals.

Voltage imbalance is defined as 100 times the sum of the division of the three voltages from the average voltage. If, for example, the three measured voltages are 221, 230, 227, the average is:

$$\frac{(221 + 230 + 227)}{3} = 226 \text{ volts}$$

Therefore, the percentage of voltage imbalance is:

$$100 * (226 - 221) / 226 = 2.2\%$$

In this example, 2.2% imbalance of more than 2.0% exists, be sure to check the voltage at the unit disconnect and terminal block switch. If an imbalance at the unit disconnect switch does not exceed 2.0%, the imbalance is caused by faulty wiring within the unit. Be sure to conduct a thorough inspection of the unit electrical wiring connections to locate the fault, and make any repairs necessary.

Table 48. Potential unit issues and solutions

Problem	Possible Cause	Remedy
Drain pan is overflowing	Plugged drain line Unit not level	Clean drain line Level unit
Standing water in drain pan	Unit not level Plugged drain line	Level Unit Clean drain line
Wet interior insulation	Coil face velocity too high Improper trap design Drain pan leaks/overflowing Condensation on surfaces	Reduce fan speed Design trap per unit installation instructions Repair Leaks Insulate surfaces
Excess dirt in unit	Missing filters Filter bypass	Replace filters Reduce filter bypass
Microbial growth (mold)	Standing water in drain pan	See "Standing water in drain pan" above

Diagnostics

Refer to the *IntelliPak™ Self-Contained Programming Guide, PKG-SVP01B-EN*, for specific unit programming and troubleshooting information. In particular, reference the "Service Mode Menu" and "Diagnostic Menu" sections in the programming guide. Refer to the following text for general diagnostic and troubleshooting procedures. Common diagnostics and troubleshooting procedures follow below.

A

Auto Reset S/A Static Pressure Limit

Problem: The supply air static pressure went too high.
Reason for Diagnostic: The S/A static pressure exceeded



Diagnosics

the S/A static pressure limit setpoint for at least one second continuously.

UCM Reaction: A "supply air pressure shutdown" signal is sent to the following functions:

- a. Compressor staging control,
- b. Economizer actuator control,
- c. Heat operation,
- d. Supply fan control,
- e. VFD control,
- f. Exhaust fan control,
- g. Exhaust actuator control

Reset Required: (PAR) The supply fan is not allowed to restart for 15 seconds after the diagnostic occurs. An auto reset will also occur if the unit cycles out of occupied mode and back.

A pressure switch installed on the suction line that prevents compressor operation below the switch's setpoint.

C

CO2 Sensor Failure

Problem: The VCM CO2 sensor input signal is out of range.

Check: Check field/unit wiring between sensor and VCM.

Reason for Diagnostic: The unit is reading a signal that is out of range for the CO2 sensor transducer input.

UCM Reaction: The CO2 reset function disables.

Reset Required: (PAR) An automatic reset occurs after the CO2 sensor transducer input receives a signal that is within range for ten continuous seconds.

Compressor Contactor Fail - Circuit 1, 2, 3, or 4

Problem: The compressor contactor for Ckt. 1, 2, 3, or 4 has malfunctioned.

Reason for Diagnostic: The circuit compressor proving input is detected closed continuously for more than three seconds while neither compressor output on that circuit closes.

UCM Reaction: A "lockout ckt #1, 2, 3, or 4 request is issued to the compressor staging control function.

Reset Required: (PMR) A manual reset is required after the diagnostic is set. It can be reset by the HI or Tracer Summit.

Compressor Trip - Ckt 1, 2, 3, or 4

Problem: The compressor ckt #1, 2, 3, or 4 has tripped.

Reason for Diagnostic: The ckt #1, 2, 3, or 4 compressor proving input is detected open continuously for more than 3 seconds when either or both compressor outputs on that circuit energize (as described in the compressor protection function).

Reason for Diagnostic: The circuit compressor proving input is detected open continuously for more than 3 seconds when either or both compressor outputs on that

circuit energize (as described in the compressor protection function).

UCM' Reaction: A "lockout ckt #1, 2, 3, or 4" request is issued to the compressor staging control function.

Reset Required: (PMR) A manual reset is required after this diagnostic occurs. The diagnostic can be reset by the unit mounted HI module or Tracer Summit.

Condenser Temp Sensor Failure - Circuit 1, 2, 3, or 4

Problem: The saturated condenser temperature input is out of range for circuit #1, 2, 3, or 4.

Check: Sensor resistance should be between 830 ohms (200°F) and 345.7 ohms (-40°F). If so, check field/unit wiring between sensor and MCM/SCM.

Reason for Diagnostic: The unit is reading a signal that is out of range for the circuit #1, 2, 3, or 4 saturated condenser temperature sensor. (temp < -55°F or temp > 209°F).

UCM Reaction: A "Lockout Ckt # 1, 2, 3, or 4" request is issued to the compressor staging control function.

Reset Required: (PAR) An automatic reset occurs after the circuit 1, 2, 3, or 4 condenser temp input returns to its allowable range within 10 seconds.

D

Dirty Filter

Problem: There is a dirty filter.

Reason for Diagnostic: The filter switch input on the RTM is closed for more than 60 seconds continuously.

UCM Reaction: An information only diagnostic is set.

Reset Required: (INFO) An automatic reset occurs after the dirty filter input reopens for 60 continuous seconds.

E

ECEM Communications Failure

Problem: The RTM has lost communication with the ECEM.

Check: Field/unit wiring between RTM and ECEM module.

Reason for Diagnostic: The RTM has lost communication with the ECEM.

UCM Reaction: If the unit has the comparative enthalpy option, the economizer enable r.e. enthalpy function will revert to level 2 enthalpy comparison.

Reset Required: (PAR) An automatic reset occurs after communication has been restored.

Emergency Stop

Problem: The emergency stop input is open.

Reason for Diagnostic: An open circuit has occurred on the emergency stop input caused either by a high duct temp t-stat trip, or the opening of field-provided contacts, switch, etc.

UCM Reaction: Off or close requests are issued as appropriate to the following functions;

- a. Compressor staging/chilled water cooling control
- b. Heat operation
- c. Supply fan control and proof of operation
- d. Exhaust fan control and proof of operation.
- e. Exhaust actuator control
- f. Outside air damper control
- g. On VAV units, VFD control

Reset Required: (PMR) A manual reset is required after the emergency stop input recloses. The diagnostic can be reset by the HI.

Entering Cond Water Temp Sensor Fail

Problem:

Activation Conditions: temperature < -50°F or temperature > 209°F, and unit configured for water cooled condenser

- c. Time to React: 10 sec < T < 20 sec
- d. DiagnosticText (Human Interface Display) "ENT COND WATERTEMP SENSOR FAIL"
- e. Actions to be Initiated: A "Lockout All Ckts " request is issued to the "Compressor Staging Function"
- f. Reset: An automatic reset occurs after the entering condenser water temperature input returns to within range continuously for 15 seconds.

Entering Water Temp Sensor Fail

- a. Data used (module, packet, byte, bit): WSM, 01,18,05
- b. Activation Conditions: temperature < -50°F or temperature > 209°F, and unit configured with water cooled condenser and/or economizer
- c. Time to React: 10 sec < T < 20 sec
- d. DiagnosticText (Human Interface Display) "ENTERING WATERTEMP SENSOR FAIL"
- e. Actions to be Initiated: A "Disable Water Side Economizer" request is issued to "Water Side Economizer Temperature Enable Function"
- f. Reset: An automatic reset occurs after the Entering Water Temp. input returns to within range continuously for 10 seconds.

Evap Temp Sensor Failure - Circuit 1, 2, 3, or 4

Problem: The evaporator temperature sensor (ckt #1, 2, 3, or 4) is out of range.

Check: Sensor resistance should be between 830 ohms (200°F) and 345.7 Kohms (-40°F). If so, check field/unit wiring between sensor and MCM/SCM.

Reason for Diagnostic: The unit is reading a signal that is out of range for the circuit #1 evaporator temperature sensor input (temp < -55°F or temp > 209°F).

UCM Reaction: The coil frost protection function for the refrigeration circuit (#1, 2, 3, or 4) only is disabled.

Reset Required: (PAR) An automatic reset occurs after the #1, 2, 3, or 4 evap temp input returns to its allowable range for 10 seconds.

G

GBAS 0-5 VDC Module Comm Failure

Problem: The RTM has lost communication with the GBAS module.

Check: Field/unit wiring between RTM and GBAS.

Reason for Diagnostic: The RTM has lost communication with the GBAS module.

UCM Reaction: The UCM will initiate the following actions;

- a. If the demand limit input was closed prior to the communications loss, then the demand limit commands issued to the heat operation function (if applicable) and the compressor staging/chilled water cooling function will be cancelled.
- b. If any of the GBAS setpoint control parameters are the HI-selected setpoint sources, then those setpoints will revert to the default HI setpoints.
- c. Any active GBAS output control parameters will be ignored.
- d. A failsafe function in the GBAS module will cause all GBAS outputs to be zeroed and deenergized.

Reset Required: (PAR) An automatic reset occurs after communication has been restored.

H

Heat Failure

Problem: The heat has failed.

(Electric heat unit) Typically, this is because the electric heat section became too hot.

Reason for Diagnostic: The heat fail input on the heat module was closed:

- a. for more than 80 seconds,
- b. for ten consecutive occurrences (each lasting five seconds or more) within a 210 second period.

UCM Reaction: An information only diagnostic is set.

Reset Required: (INFO) An automatic reset occurs after the heat fail input remains open for 210 seconds continuously.

Heat Module Auxiliary Temperature Sensor Fail

Problem: The heat mod aux temp sensor input is out of range.

Check: Sensor resistance should be between 830 ohms (200°F) and 345.7 ohms (-40°F). If so, check field/unit wiring between sensor and heat module.

Reason for Diagnostic: At least one enabled unit function has the heat module auxiliary temperature input designated as its sensor, and the unit is reading a signal that is out of range for this input (temp < -55°F or temp > 209°F).



Diagnosics

UCM Reaction: The functions that designated the heat module auxiliary temperature input as their input are disabled.

Reset Required: (PAR) An automatic reset occurs after the heat module auxiliary temperature input returns to its allowable range for 10 seconds.

Heat Module Comm Failure

Problem: The RTM has lost communication with the heat module.

Check: Check field/unit wiring between RTM and heat module.

Reason for Diagnostic: The RTM has lost communication with the heat module.

UCM Reaction: An "all heat off" request is sent to the heat operation function.

If the unit has staged gas or electric heat, all heat module outputs will be zeroed and deenergized.

If the unit has hydronic heat or chilled water installed, the unit will turn off the supply fan and close the outside air damper upon the occurrence of a heat module comm failure. A failsafe function in the heat module will cause all water valves to be set to 100% to provide full water flow. Unless used for switching purposes (air handlers with chilled water and mod gas, or chilled water and hydronic heat) all binary outputs will be deenergized.

Reset Required: (PAR) An automatic reset occurs after communication has been restored.

L

Low Air Temp Limit Trip

Problem: The low air temp limit has tripped. (Units with steam or hot water heating, or air handlers with chilled water cooling)

Reason for Diagnostic: A low air temp limit trip is detected continuously for more than one second. This can occur if the hydronic heat low air temp limit input closes for > 1 second, or if the chilled water low air temp limit trip input opens for > 1 second. On units with both hydronic heat and chilled water, both low air temp limit inputs are active, and the unit will respond in the same manner regardless of which input is used.

UCM Reaction: The UCM will initiate the following actions;

- An "open all water valves" request is issued to the heat module function, causing any steam, hot water, or chilled water valves on the unit to open.
- An "all heat off" request is issued to the heat control function.
- A "fan off" request is sent to the supply fan control function.
- A "close damper" request is sent to the economizer actuator control function.

Reset Required: (PMR) A manual reset is required after the low air temp limit trip condition clears. The diagnostic can be reset at the unit mounted human interface, by Tracer Summit, or by cycling power to the RTM.

Low Pressure Control Open - Circuit 1, 2, 3, or 4

Problem: The Low Pressure Control (LPC) for Ckt #1, 2, 3, or 4 is open.

Check: State of refrigerant charge for ckt #1, 2, 3, or 4.

Reason for Diagnostic: The Ckt # 1 LPC input is detected open as described in the compressor protection function.

UCM Reaction: A "Lockout Ckt # 1, 2, 3, or 4" request is issued to the compressor staging control function.

Reset Required: (PMR) A manual reset is required anytime after the diagnostic is set. The diagnostic can be reset by the human interface, Tracer Summit, or by cycling power to the RTM.

M

Manual Reset SA Static Press Limit

Problem: The supply air static pressure went too high for the third consecutive time.

Reason for Diagnostic: The auto reset supply air static pressure limit diagnostic has occurred for the third time while the unit is operating in occupied mode.

UCM Reaction: A "supply air pressure shutdown" signal is sent to the following functions;

- Compressor staging control,
- Economizer actuator control,
- Heat operation,
- Supply fan control,
- VFD control,
- Exhaust fan control
- Exhaust actuator control

Reset Required: (PMR) A manual reset is required and can be accomplished at the HI, Tracer Summit, or by cycling power to the RTM.

MCM Communications Failure

Problem: The RTM has lost communication with the MCM.

Check: Check field/unit wiring between RTM and MCM.

Reason for Diagnostic: The RTM has lost communications with the MCM.

UCM Reaction: A "Lockout" request is sent to the compressor staging control function. And a failsafe function in the MCM will cause all MCM outputs to be zeroed and deenergized.

Reset Required: (PAR) An automatic reset occurs after communication has been restored.

Mode Input Failure

Problem: The RTM mode input is out of range.

Check: Sensor resistance should be between 1 ohm and 40 ohms. If so, check field/unit wiring between sensor and RTM.

Reason for Diagnostic: The mode input signal on the RTM is out of range (resistance < 1 ohm or resistance > 40 ohms).

UCM Reaction: The system mode reverts to the default (HI set) system mode.

Reset Required: (INFO) An automatic reset occurs after the mode input returns to its allowable range for 10 seconds.

N

NSB Panel Zone Temperature Sensor Failure

Problem: The NSB panel's zone temp sensor input is out of range. (This input is at the NSB panel, not on the unit itself).

Check: If have an external sensor connected to the NSB panel zone sensor input, then the internal NSB panel zone sensor should be disabled. Verify sensor resistance. If in valid range, check wiring between the sensor and NSB panel.

NSB Panel Comm Failure

Problem: The RTM has lost communications with the night setback panel (programmable zone sensor).

Check: Field/unit wiring between RTM and NSB Panel.

Reason for Diagnostic: The RTM has lost communication with the NSB panel.

UCM Reaction: The unit reverts to the next lower priority mode switching source (typically the HI default mode). If the NSB panel zone sensor is the designated sensor source for any functions, those functions are disabled.

Reset Required: (PAR) An automatic reset occurs after communication has been restored.

O

O/A Humidity Sensor Failure

Problem: The outside air humidity sensor data is out of range.

Check: Check field/unit wiring between the sensor and RTM.

Reason for Diagnostic: The unit is reading a signal that is out of range for the outside air humidity sensor (humidity < 5% or humidity > 100%).

UCM Reaction: The economizer enable enthalpy function reverts to dry-bulb temperature changeover ("Level 1") control.

Reset Required: (PAR) An automatic reset occurs after the OA humidity input returns to its allowable range for 10 seconds.

O/A Temp. Sensor Failure

Problem: The outside air temperature sensor input is out of range.

Check: Sensor resistance should be between 830 ohms (200°F) and 345.7 ohms (-40°F). If so, check field/unit wiring between sensor and RTM.

Reason for Diagnostic: The unit is reading a signal that is out of range for the outside air temperature input on the RTM (temp. < -55°F or temp > 209°F).

UCM Reaction: These unit functions occur:

- low ambient compressor lockout disables
- O/A damper drives to minimum position
- on VAV units with S/A temp. reset type selected as O/A temp. reset, the reset type reverts to "none" for the duration of the failure

Reset Required: (PAR) an automatic reset occurs after the O/A temperature input returns to its allowable range. To prevent rapid cycling of the diagnostic, there is a 10 second delay before the automatic reset.

Occupied Zone Heat Setpoint Failure

Problem: The occupied zone heat setpoint input is out of range.

Reason for Diagnostic: The input designated as occupied zone heating setpoint source is out of range for the outside air temperature input on the RTM (temp. < 45°F or temp > 94°F).

UCM Reaction: The active occupied zone heating setpoint reverts to the default value.

Reset Required: (PAR) an automatic reset occurs after the occupied zone heating setpoint input returns to its allowable range for 10 continuous seconds, or after a different occupied zone heating setpoint selection source is user-defined.

R

Return Air Humidity Sensor Failure

Problem: On units with both airside economizer and comparative enthalpy installed, the return air humidity sensor input is out of range.

Check: Check field/unit wiring between the sensor and ECEM.

Reason for Diagnostic: The unit is reading a signal that is out of range for the return air humidity sensor (humidity < 5% or humidity > 100%).

UCM Reaction: The economizer enable r.e. enthalpy function reverts to reference enthalpy changeover ("Level 2") control.

Reset Required: (PMR) An automatic reset occurs after the RA humidity input returns to its allowable range continuously for 10 seconds.



Diagnostics

Return Air Temp Sensor Failure

Problem: On units with the comparative enthalpy option, the return air temperature sensor input is out of range.

Check: Sensor resistance should be between 830 ohms (200°F) and 345.7 ohms (-40°F). If so, check field/unit wiring between the sensor and ECEM.

Reason for Diagnostic: The unit is reading a signal that is out of range for the return air humidity sensor (temp < -55°F or temp > 209°F).

UCM Reaction: The economizer enable r.e. enthalpy function reverts to reference enthalpy changeover ("Level 2") control.

Reset Required: (PAR) An automatic reset occurs after the RA temp input returns to its allowable range continuously for 10 seconds.

RTM Aux. Temp. Sensor Failure

Problem: The RTM auxiliary temperature sensor data is out of range.

Check: Sensor resistance should be between 830 ohms (200°F) and 345.7 ohms (-40°F). If so, check field/unit wiring between sensor and RTM.

Reason for Diagnostic: At least one enabled unit function has the RTM auxiliary temperature input designated as its sensor, and the unit is reading a signal that is out of range for this input (temp. < -55°F or temp > 209°F).

UCM Reaction: The functions with the RTM auxiliary temperature input designated as their sensor are disabled.

Reset Required: (PAR) an automatic reset occurs after the designated zone temperature signal returns to its allowable range. To prevent rapid cycling of the diagnostic, there is a 10 second delay before the automatic reset.

RTM Data Storage Error

Problem: There was a data transmission error.

Check: This can be caused by an intermittent power loss. Turn the unit off for 1-2 minutes, then back on again. If diagnostic persists, then the RTM may need to be replaced.

Reason for Diagnostic: An error occurred while the RTM was writing data to its internal non-volatile memory (EEPROM).

UCM Reaction: An information only diagnostic will be displayed at the human interface.

Reset Required: (INFO) A manual reset may be made at the human interface, at Tracer Summit, or by cycling power to the RTM.

RTM Zone Sensor Failure

Problem: The RTM zone temperature sensor input is out of range.

Check: Sensor resistance should be between 830 ohms (200°F) and 345.7 ohms (-40°F). If so, check field/unit wiring between sensor and RTM.

Reason for Diagnostic: At least one enabled unit function has the RTM zone temperature input designated as its sensor, and the unit is reading a signal that is out of range for this input (temp. < -55°F or temp > 150°F).

UCM Reaction: The functions with the RTM zone temperature input designated as their sensor are disabled.

Reset Required: (PAR) an automatic reset occurs after the designated zone temperature signal returns to its allowable range. To prevent rapid cycling of the diagnostic, there is a 10 second delay before the automatic reset.

S

SCM Communication Failure

Problem: The RTM has lost communication with the SCM.

Check: Check field/unit wiring between the RTM and SCM.

Reason for Diagnostic: The RTM has lost communication with the SCM.

UCM Reaction: A "lockout" request is sent to the compressor staging control function. A failsafe function in the SCM will cause all SCM outputs to be zeroed and deenergized.

Reset Required: (PAR) An automatic reset occurs after communication has been restored.

Space Static Press Setpt Failure

Problem: The active space static pressure setpoint is out of range.

Check: Check setpoint value. Also, if space pressure setpoint source is GBAS, but this setpoint has not been assigned to any of the four analog inputs on GBAS, this message will occur.

Reason for Diagnostic: The unit is reading a signal that is out of range for the space static pressure setpoint (input < 0.03 iwc or input > 0.20 iwc).

UCM Reaction: The default space pressure setpoint will become the active space pressure setpoint.

Reset Required: (PAR) An automatic reset occurs after the designated space pressure setpoint source sends a signal within range for 10 continuous seconds, or after a different space pressure setpoint source is user-defined.

Supply Air Pressure Sensor Failure

Problem: The supply air pressure sensor voltage input is out of range.

Check: Check field/unit wiring between the sensor and RTM.

Reason for Diagnostic: The unit is reading a signal that is out of range for the supply air pressure sensor voltage input (input < 40mV or input > 4.75V)

UCM Reaction: The following functions are disabled;

- a. SA pressure control
- b. SA static pressure limit

Reset Required: (PAR) An automatic reset occurs after the SA temp heating setpoint input returns to within range for 10 continuous seconds, or after a different SA temp heating setpoint selection source is user-defined.

Supply Air Pressure Setpoint Failure

Problem: The SA pressure input signal is out of range.

Reason for Diagnostic: The SA pressure setpoint input is sending a signal that is out of range (Input < 1.0 iwc or input > 4.3 iwc)

UCM Reaction: The default SA pressure setpoint will become the active SA pressure setpoint.

Reset Required: (PAR) An automatic reset occurs after the designated SA pressure setpoint source sends a signal within range for 10 continuous seconds, or after a different SA pressure setpoint source is user-defined.

Supply Air Temp Cool Setpoint Fail

Problem: The active supply air temperature cooling setpoint is out of range.

Reason for Diagnostic: The input designated as the SA temp cooling setpoint is out of range (temp < 35°F or temp > 95°F).

UCM Reaction: The default HI-set SA temp cooling setpoint becomes the active SA temp cooling setpoint.

Reset Required: (PAR) An automatic reset occurs after the SA temp cooling setpoint input returns to within range for 10 continuous seconds, or after a different SA temp cooling setpoint selection source is user-defined.

Supply Air Temp Heat Setpoint Fail

Problem: The active supply air temperature cooling setpoint is out of range.

Reason for Diagnostic: The input designated as the SA temp heating setpoint is out of range (temp < 35°F or temp > 185°F).

UCM Reaction: The default HI-set SA temp heating setpoint becomes the active SA temp heating setpoint.

Reset Required: (PAR) An automatic reset occurs after the SA temp heating setpoint input returns to within range for 10 continuous seconds, or after a different SA temp heating setpoint selection source is user-defined.

Supply Air Temperature Failure

Problem: The supply air temperature sensor input is out of range.

Check: Sensor resistance should be between 830 ohms (200°F) and 345.7 ohms (-40°F). If so, check field/unit wiring between sensor and RTM.

Reason for Diagnostic: The unit is reading a signal that is out of range for the supply air temperature input on the RTM (temp. < -55°F or temp > 209°F).

UCM Reaction: These unit functions are disabled:

- supply air tempering
- economizing
- supply air temperature low limit function (CV units)
- supply air temperature control heating and cooling functions (VAV units)

Reset Required: (PAR) an automatic reset occurs after the designated S/A temperature input returns to its allowable range. To prevent rapid cycling of the diagnostic, there is a 10 second delay before the automatic reset.

Supply Fan Failure

Problem: There is no supply airflow indication after the supply fan is requested on.

Check: Check belts, linkages, etc. on the supply fan assembly. If these are ok, check field/unit wiring between RTM and supply fan. If the supply fan runs in service mode, then verify airflow proving switch and wiring.

Reason for Diagnostic: The supply airflow input is detected OPEN for 40 continuous seconds during any period of time in which the supply fan binary output is ON. between 830 ohms (200°F) and 345.7 ohms (-40°F). If so, check field/unit wiring between the sensor and MCM.

This input is ignored for up to 5 minutes after the supply fan starts, until airflow is first detected.

UCM Reaction: "Off" or "Close" requests are issued as appropriate to the following functions;

- a. Compressor staging/chilled water control
- b. Heat operation
- c. Supply fan control & proof of operation
- d. Exhaust fan control & proof of operation
- e. Exhaust actuator control
- f. Economizer actuator control
- g. VFD control

Reset Required: (PMR) A manual reset is required anytime after the diagnostic is set. The diagnostic can be reset at the HI, Tracer Summit, or by cycling power to the RTM.

Supply Fan VFD Bypass Enabled

- a. Data used (module,packet,byte,bit): RTM
- b. Activation conditions: supply fan VFD bypass has been activated and supply fan vfd bypass is installed.
- c. Time to React: 10 sec < T < 20 sec
- d. Diagnostic text (human interface display)
SUPPLY FAN VFD BYPASS ENABLED"
- e. Actions to be Initiated: NONE
- f. Reset: The INFO diagnostic is cleared when the supply fan VFD bypass is deactivated.

T***LCI Module Comm Failure***

Problem: The RTM has lost communication with the LCI.

Check: Check field/unit wiring between RTM and LCI module.

Reason for Diagnostic: The RTM has lost communication with the LCI module.

UCM Reaction: All active commands and setpoints provided by Tracer Summit through the LCI will be cancelled and/or ignored. And where Tracer Summit has been designated as setpoint source, local HI default setpoints will be used.

Reset Required: (PAR) An automatic reset occurs after communication has been restored.

Tracer Communications Failure

Problem: LCI has lost communication with Tracer Summit.

Check: Tracer Summit (building control panel) is powered up and running properly. If so, check unit wiring between LCI and Tracer Summit (building control panel).

Reason for Diagnostic: The LCI has lost communications with Tracer Summit for > 15 minutes.

UCM Reaction: All active commands and setpoints provided by Tracer Summit through the LCI will be cancelled and/or ignored. And where Tracer Summit has been designated as the setpoint source, local HI default setpoints are used.

Reset Required: (PAR) An automatic reset occurs after communication between Tracer Summit and the LCI is restored.

U***Unit HI Communications Failure***

Problem: The RTM has lost communication with the unit mounted (local) human interface (HI).

Check: Field/unit wiring between RTM and local HI.

Reason for Diagnostic: The RTM has lost communication with the unit-mounted human interface.

UCM Reaction: A fail-safe function in the HI will cause the following sequence:

- a. disallow any interaction between the HI and the RTM (or any other modules),
- b. render all HI keystrokes ineffective
- c. cause the following message to display on the unit-mounted HI display: "Local HI communications loss. Check comm link wiring between modules." If the unit has a remote HI option, then this diagnostic will display as any other automatic reset diagnostic.

Reset Required: (INFO) An automatic reset occurs after communication is restored between the RTM and the HI. When the failure screen clears, the general display restores to allow the HI to interact with the RTM again.

Unoccupied Zone Cool Setpoint Failure

Problem: The unoccupied zone cooling setpoint input is out of range.

Reason for Diagnostic: The input designated as the unoccupied zone cooling setpoint source is out of range (temp < 45°F or temp > 94°F).

UCM Reaction: The active unoccupied zone cooling setpoint reverts to the default value.

Reset Required: (PAR) An automatic reset occurs after the designated unoccupied zone cool setpoint input returns to its allowable range for 10 continuous seconds, or after the user defines a different, valid unoccupied zone cool setpoint selection source.

Unoccupied Zone Heat Setpoint Failure

Problem: The unoccupied zone heating setpoint input is out of range.

Reason for Diagnostic: The input designated as unoccupied zone heating setpoint source is out of range (temp < 45 F or temp > 94 F).

UCM Reaction: The active unoccupied zone heating setpoint reverts to the default value.

Reset Required: (PAR) An automatic reset occurs after the designated unoccupied zone heat setpoint input returns to its allowable range for 10 continuous seconds, or after the user defines a different, valid unoccupied zone heating setpoint selection source.

V***VCM Communication Failure***

Problem: The RTM has lost communication with the VCM.

Verify: Check field/unit wiring between RTM and VCM.

Reason for Diagnostic: RTM has lost communication with VCM.

UCM Reaction: All active commands and setpoints provided by the VCM are canceled and/or ignored. A fail-safe function in the VCM will cause all outputs to deenergize and/or set to zero. The outside air damper minimum position function will revert to using the O/A flow compensation function if O/A flow compensation is enabled or set to the default minimum position function if O/A flow compensation is disabled or not available.

Reset Required: (PAR) An automatic reset occurs after communication is restored.

communications with the VOM.

Velocity Pressure Sensor Failure

Problem: The velocity pressure input signal is out of range.

Check: Check field/unit wiring between sensor and VCM.

Reason for Diagnostic: The unit is reading a signal that is out of range for the velocity pressure transducer input (during calibration: V < 40 mV or V > 420 mV, during operation: V < 40 mV or V > 0.75 V).

UCM Reaction: The minimum airflow control function is disabled. The outside air damper minimum position function reverts to using the O/A flow compensation function if O/A flow compensation is enabled or to the default minimum position function if O/A flow compensation is disabled or not available.

Reset Required: (PAR) An automatic reset occurs after the designated space pressure transducer sends a signal within range for 10 continuous seconds.

VOM Communications Failure

Problem: The RTM has lost communication with the VCM.

Check: Field/unit wiring between RTM and VCM.

Reason for Diagnostic: The RTM has lost communications with the VOM.

UCM Reaction: Ventilation override actions will not be allowed, and the VO Output relay will be deenergized.

Reset Required: (PAR) An automatic reset occurs after communication has been restored.

W

WSM Communications Fail

Problem: The RTM has lost communication with the WSM.

Check: Field/unit wiring between RTM and WSM.

Reason for Diagnostic: RTM has lost communication with WSM.

UCM Reaction: UCM will react as if a freeze stat has occurred by issuing:

- "all heat on" or "mod output full open" request to "heat control"
- A "fan off" request to "supply fan control"
- "close damper" request to "economizer actuator control"
- Water pump to turn on and position all water valves to provide maximum flow through all water source heat exchangers
- Disables preheat function if WSM mixed air temp sensor is selected as preheat sensor

Reset Required: An automatic reset occurs after one complete set of IPC packets is received.

WSM Mixed Air Temp Sensor Fail

b. Activation Conditions: temperature <-50°F or temperature >209°F, and sensor is selected for use by "waterside economizer temperature enable function" or "preheat function"

c. Time to React: 10 sec < T < 20 sec

e. Actions to be Initiated: "waterside economizer temperature enable function" uses supply air cooling setpoint instead of mixed air temperature. If mixed air temperature is used for "preheat function", issue a "disable" request to "preheat function"

f. Reset: An automatic reset occurs after mixed air temp. input returns to within range continuously for 10 seconds.

Water Flow Fail

a. Data used (module, packet, byte, bit): WSM, 01, 19, 05

- b. Activation Conditions: Water flow input is detected open
1. at the end of precool water flow initiation state, or
 2. continuously for five minutes while:
 - water side economizer is open 100%,
 - presetting of a head pressure valve, or
 - demand for mechanical cooling.

Unit must be: a. configured with water cooled condenser and/or water economizer and b. have water flow switch installed.

c. Time to React: immediate

e. Actions to be Initiated: A "lockout all ckts" request is issued to the "compressor staging function"

f. Reset: Automatic reset occurs after water flow input returns to within range continuously for 3 seconds, water pump is requested OFF, or water flow switch becomes not installed.

Z

Zone Cool Setpoint Failure

Problem: Occupied zone cooling setpoint is out of range.

Reason for Diagnostic: Input designated as occupied zone cooling setpoint source is out of range (temp. < 45°F or > 94°F).

UCM Reaction: The active occupied zone cooling setpoint reverts to the default occupied zone cooling setpoint.

Reset Required: (PAR) an automatic reset occurs after designated occupied zone CSP input returns to its allowable range for 10 continuous seconds, or after a different valid occupied zone CSP selection source is user-defined.



Wiring Diagrams

Note: For easier access, published unit wiring diagrams (individual, separate diagrams for unitary product lines) will become available via e-Library instead of through wiring manuals after 2007.

Drawing Number	Description
2307-8257	Field Wiring Diagram S*WF 20 -80T & S*RF 20-60T
2307-8258	Schematic Diagram With VFD Single Point Pwr S*WF 20-80T S*RF 20-60T
2307-8260	Schematic Diagram With VFD RTM Modual S*WF 20-80T S*RF 20-60T
2307-8262	Schematic Diagram With VFD W/Bypass RTM Modual S*WF 20-80T S*RF 20-60T
2307-8263	Connection Diagram With VFD W/ or W/O Bypass S*WF 20-80T S*RF 20-60T
2307-8295	Schematic Diagram With VFD Dual Point Pwr S*WF 20-80T S*RF 20-60T
2307-8296	Schematic Diagram With VFD W/Bypass Dual Point Pwr S*WF 20-80T S*RF 20-60T
2307-8298	Schematic Diagram With VFD Single Point Pwr S*WF 85T
2307-8299	Schematic Diagram With VFD W/Bypass Single Point Pwr S*WF 85T
2307-8301	Connection Diagram With VFD W/ or W/O Bypass S*WF 20-80T S*RF 20-60T
2307-8331	Connection Diagram With VFD W/ or W/O Bypass S*WF 20-80T S*RF 20-60T
2307-8333	Connection Diagram With VFD W/ or W/O Bypass S*WF 42-80T S*RF 40-60T
2307-8349	Connection Diagram W/ or W/O VFD W/ or W/O Bypass S*WF 20-80T S*RF 20-60T
2307-8404	Field Wiring Diagram Single Point Pwr S*WF 85T
2307-8406	Schematic Diagram With VFD RTM Modual S*WF 85T
2307-8407	Schematic Diagram With VFD W/Bypass RTM Modual S*WF 85T
2307-8412	Connection Diagram CV S*WF 85 Ton
2307-8415	Connection Diagram W/ VFD W/Bypass S*WF 85 Ton
2307-8416	Connection Diagram W/ or W/O VFD W/ or W/O Bypass S*WF 85T
2307-8424	Connection Diagram W/ VFD W/ or W/O Bypass S*WF 85 Ton
2307-8505	Connection Diagram With VFD W/ or W/O Bypass S*WF 20-38T S*RF 20-38T
2307-8259	Schematic Diagram With VFD W/Bypass Single Point Pwr S*WF 20-80T S*RF 20-60T
2309-4612	Connection Diagram With VFD W/ or W/O Bypass S*WF 90, 100 & 110T
2309-4601	Schematic Diagram With VFD Sinlge Point Pwr 90 -110T
2309-4602	Schematic Diagram With VFD W/Bypass Sinlge Point Pwr 90 -110T
2309-4603	Schematic Diagram With VFD RTM Modual S*WF 90 - 110T
2309-4604	Schematic Diagram With VFD W/Bypass RTM Modual S*WF 90 - 110T
2309-4608	Connection Diagram With VFD W/ or W/O Bypass S*WF 90, 100 & 110T
2309-4609	Connection Diagram With VFD W/ or W/O Bypass S*WF 90, 100 & 110T
2309-4610	Connection Diagram With VFD W/ or W/O Bypass S*WF 90, 100 & 110T
2309-4611	Connection Diagram With VFD W/ or W/O Bypass S*WF 90, 100 & 110T
2309-4613	Field Wiring Diagram Single Point Pwr S*WF 90 - 110T
2307-8413	Connection Diagram W/ VFD W/ or W/O Bypass S*WF 85 Ton
2307-8411	Connection Diagram W/ VFD W/ or W/O Bypass S*WF 85 Ton
2307-8251	Schmematic Diagram CV Single Point Pwr S*WF 20-80T S*RF 20-60T
2307-8294	Schmematic Diagram CV Dual Point Pwr S*WF 20-80T S*RF 20-60T
2307-8259	Schmematic Diagram W/VFD W/Bypass Single Point Pwr S*WF 20-80T S*RF 20-60T
2307-8253	Schematic Diagram CV RTM Modual S*WF 20-80T S*RF 20-60T
2307-8277	Schematic Diagram Water-Cooled S*WF 20-80T
2307-1015	Schematic Diagram Air-Cooled S*RF 30 - 50T
2307-8278	Schematic Diagram Air-Cooled S*RF 60T
2307-8279	Schematic Diagram Air-Cooled S*RF 20, 25 & 29T
2307-8255	Schematic Diagram Heat, Vent Cntrl & GBAS S*WF 20-80T S*RF 20-60T
2307-8256	Schematic Diagram ECEM, VOM LCI, IPCB, HI & RHI Mod S*WF 20-80T S*RF 20-60T
2307-8261	Connection Diagram CV S*WF 20-80 & S*RF 20-60T

Drawing Number	Description
2307-8300	Connection Diagram CV S*WF 20-80 & S*RF 20-60T
2307-8330	Connection Diagram CV S*WF 20-80 & S*RF 20-60T
2307-8297	Connection Diagram CV S*WF 85T
2307-8405	Connection Diagram CV RTM Modul S*WF 85T
2307-8293	Schematic Diagram Water-Cooled S*WF 85T
2307-8408	Schematic Diagram Heat, Vent Cntrl & GBAS S*WF 85T
2307-8409	Schematic Diagram ECEM, VOM LCI, IPCB, HI & RHI Mod S*WF 20-80T S*RF 20-60T
2307-8410	Connection Diagram CV S*WF 85T
2307-8414	Connection Diagram CV S*WF 85T
2309-4605	Schematic Diagram Water-Cooled S*WF 90, 100 & 110T
2309-4606	Schematic Diagram Heat, Vent Cntrl & GBAS S*WF 90, 100 & 110T
2309-4607	Schematic Diagram ECEM, VOM LCI, IPCB, HI & RHI Mod S*WF 90, 100 & 110T
2307-8359	Field Wiring Diagram Ipak Controls CCRC 20-60 Ton
2307-8332	Schematic Diagram Ipak Controls CCRC 20, 29 & 32 Ton
2307-8282	Schematic Diagram Ipak Controls CCRC 35 & 40 Ton
2307-8283	Schematic Diagram Ipak Controls CCRC 50 & 60 Ton
2308-8284	Connection Diagram With Ipak Controls CCRC 20-60 Ton



Trane optimizes the performance of homes and buildings around the world. A business of Ingersoll Rand, the leader in creating and sustaining safe, comfortable and energy efficient environments, Trane offers a broad portfolio of advanced controls and HVAC systems, comprehensive building services, and parts. For more information, visit www.Trane.com.

Trane has a policy of continuous product and product data improvement and reserves the right to change design and specifications without notice.

© 2014 Trane All rights reserved
SCXF-SVX01K-EN 02 Jul 2014
Supersedes SCXF-SVX01J-EN (23 Oct 2012)

We are committed to using environmentally
conscious print practices that reduce waste.

