



Product Catalog

Packaged Rooftop Air Conditioners Voyager™ – Heat Pump 12½ – 20 Tons – 60 Hz





Introduction

Packaged Rooftop Air Conditioners

Through the years, Trane has designed and developed the most complete line of Packaged Rooftop products available in the market today. Trane was the first to introduce the Micro—microelectronic unit controls—and has continued to improve and revolutionize this design concept.

The ReliaTel control platform offers the same great features and functionality as the original Micro, with additional benefits for greater application flexibility.

Voyager continues to provide the highest standards in quality and reliability, comfort, ease of service, and the performance of Trane light commercial products.

Trane customers demand products that provide exceptional reliability, meet stringent performance requirements, and are competitively priced. Trane delivers all of this with Voyager.

Voyager features cutting edge technologies: reliable compressors, Trane engineered ReliaTel controls, computer-aided run testing, and Integrated Comfort™ Systems.

So whether you're the contractor, the engineer or the owner, you can be certain Voyager Products are built to meet your needs.

It's Hard To Stop A Trane®.

Copyright

This document and the information in it are the property of Trane, and may not be used or reproduced in whole or in part without written permission. Trane reserves the right to revise this publication at any time, and to make changes to its content without obligation to notify any person of such revision or change.

Trademarks

Trane and the Trane logo, Froststat, Integrated Comfort, ReliaTel, Tracer, are trademarks of Trane in the United States and other countries. All trademarks referenced in this document are the trademarks of their respective owners.

Revision Summary

PKGP-PRC012M-EN (12 Jun 2014)

- Updated Low Leak Economizer Factory and Field Installed Option
- Updated Features & Benefits, Model Number Description, Performance Data, Weights, and Mechanical Specifications

Table of Contents

Features and Benefits	4
Standard and Optional Features at a Glance	4
Standard Features	4
Factory Installed Options	5
Factory or Field Installed Options	5
Field Installed Options	5
Other Benefits	6
Outstanding Standard Features	6
Variety of Options	8
Factory Installed Options	8
Factory or Field Installed Options	11
Field Installed Options	12
Other Benefits	13
Application Considerations	16
Selection Procedure	17
Cooling Capacity	17
Heating Capacity	18
Model Number Description	19
Model Number Notes	20
General Data	21
Performance Data	23
Controls	34
Field Installed Control Options	34
Zone Sensors	34
Electrical Data	36
Dimensional Data	39
Weights	44
Typical Wiring	46
Jobsite Connections	50
Mechanical Specifications	51
General	51
Factory Installed Options	53
Factory or Field Installed Options	55
Field Installed Options	56



Features and Benefits

Voyager has the features and benefits that make it first class in the light commercial rooftop market. Designed with input from field contractors and engineers, its U-shaped airflow performance is outstanding.

Figure 1. Voyager features

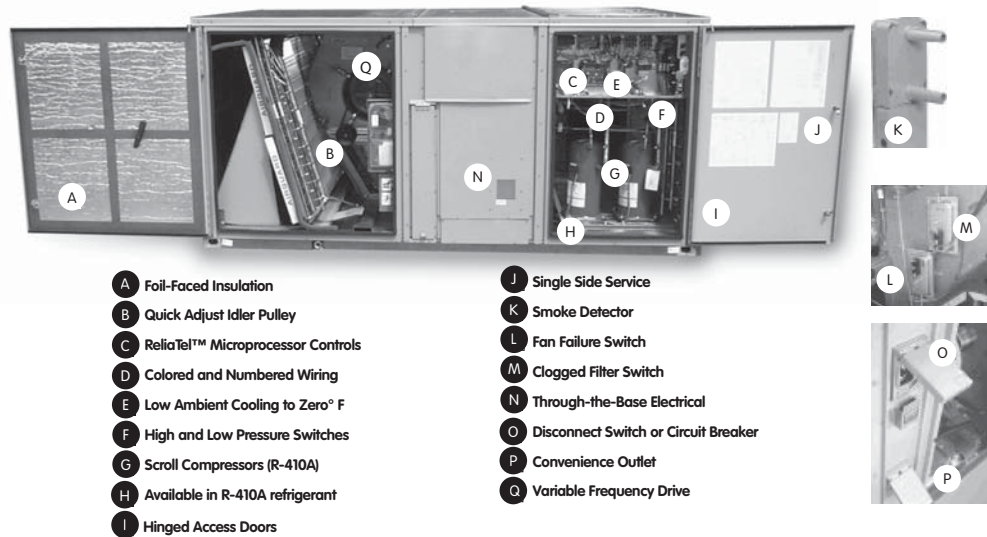

Standard and Optional Features at a Glance

Standard Features

- 2" throwaway filters
- 5 year Limited Compressor Warranty
- 1 year Limited Parts Warranty
- Anti-Short Cycle Timer
- Belt Drive Motors
- Colored and Numbered Wiring
- Crankcase Heaters
- Dedicated Airflow
- Easy Access Low Voltage Terminal Board (LTB)
- Foil-Faced and Edge Captured Insulation
- High Pressure Cutout
- IAQ Sloped Condensate Drain Pan
- Liquid Line Refrigerant Drier
- Low Ambient Cooling to 0°F
- Operating Charge of R-410A
- Patented Hybrid Condenser Coil for Easy Cleaning
- Phase Monitor
- Quick Access Panels
- Quick Adjust Idler Arm Pulley
- ReliaTel™ Microprocessor Controls
- Single Point Power
- Single Side Service
- Standardized Components

- U-shaped Airflow Pattern
- Variable Frequency Drive (Multispeed Indoor Fan and Single Zone VAV)

Factory Installed Options

- 2" MERV 8 or MERV 13 Filters⁵ with Filter Removal Tool
- Black Epoxy Pre-Coated Coils
- CO₂ Sensor Wiring (Wiring Only)¹⁵
- Condensate Overflow Switch
- Fault Detection & Diagnostics (FDD)
- High Efficiency Motors⁵
- High Short Circuit Current Rated (SCCR) Electrical Subsystem¹⁶
- Hinged Access Doors
- Human Interface - 5 inch Color Touchscreen
- Multi-Speed Fan
- Powered or Unpowered Convenience Outlet⁴
- Single Zone Variable Air Volume (SZVAV)
- Stainless Steel Drain Pan
- Supply and/or Return Air Smoke Detector^{2, 9}
- Through the Base Electrical with Circuit Breaker^{10, 11}
- Through the Base Electrical With Disconnect Switch^{6, 10, 11}
- Through the Base Utilities Access

Factory or Field Installed Options

- BACnet™ Communication Interface¹
- Barometric Relief¹
- Clogged Filter/Fan Failure Switch^{2, 5}
- Discharge Air Sensing Kit^{2, 5}
- Economizer - Standard, Downflow¹
- Electric Heaters^{5, 7, 11}
- Froststat™^{2, 5}
- Indoor Fan Motor Shaft Grounding Ring¹⁴
- LonTalk® Communications Interface⁵
- Low Leak Economizer - Downflow
- Oversized Motors⁵
- Reference or Comparative Enthalpy^{3, 5}
- ReliaTel Options Module⁸
- Tool-less Hail Guards⁵
- Trane Communications Interface (TCI)^{5, 13}

Field Installed Options

- CO₂ Sensor
- Digital Display Zone Sensor
- Dual Thermistor Remote Zone Sensor
- Economizer - Standard, Horizontal
- High Static Drive
- Low Leak Economizer - Downflow
- Manual Outside Air Damper
- Motorized Outside Air Dampers
- Powered Exhaust
- Roof Curb (Downflow only)
- Remote Potentiometer

Features and Benefits

- Ventilation Override Accessory²
- Zone Sensors and Remote Zone Sensors

Note: Explanation of Note¹ - Note¹⁶ located in “Model Number Description,” p. 19.

Other Benefits

- Cabinet Design Ensures Water Integrity
- Ease of Service, Installation and Maintenance
- Mixed Model Build Enables “Fastest in the Industry” Ship Cycle Times
- Outstanding Airflow Distribution
- ReliaTel Controls Benefits
- Rigorous Testing
- Unmatched Product Support
- Varitrac

Outstanding Standard Features

Anti-Short Cycle Timer

Provides a 3 minute minimum “ON” time and 3 minute “OFF” time for compressors to enhance compressor reliability by assuring proper oil return.

Colored and Numbered Wiring

Save time and money tracing wires and diagnosing the unit.

Compressors

Voyager contains the best compressor technology available to achieve the highest possible performance. Dual compressors are outstanding for humidity control, light load cooling conditions and system back-up applications. Dual compressors are available on all models.

Condenser Coil

Voyager boasts a patent-pending 1+1+1 condenser coil (pictured right), permanently gapped for easy cleaning.



Controls—ReliaTel

ReliaTel microprocessor controls provide unit control for heating, cooling and ventilating utilizing input from sensors that measure indoor and outdoor temperature and other zone sensors. ReliaTel also provides outputs for building automation systems and expanded diagnostics. For a complete list of ReliaTel offerings, refer to “Other Benefits,” p. 13.

Conversion-less Units

The dedicated design units (either downflow or horizontal) require no panel removal or alteration time to convert in the field — a major cost savings during installation. Horizontal units come complete with duct flanges so the contractor doesn’t have to field fabricate them. These duct flanges are a time and cost saver.

Crankcase Heaters

These band or insertion heaters provide improved compressor reliability by warming the oil to prevent migration during off-cycles or low ambient conditions. These are standard on all Voyager models.

Discharge Line Thermostat

A bi-metal element discharge line thermostats installed as a standard feature on the discharge line of each system. This standard feature provides extra protection to the compressors against high discharge temperatures in case of loss of charge, extremely high ambient and other conditions which could drive the discharge temperature higher.

Easy Access Low Voltage Terminal Board Foil Faced Insulation



Voyager's Low Voltage Terminal Board is external to the electrical control cabinet. It is extremely easy to locate and attach the thermostat wire and test operation of all unit functions. This is another cost and time saving installation feature.



All panels in the evaporator section of the unit have cleanable foil-faced insulation. All edges are either captured or sealed to ensure no insulation fibers get into the airstream.

Low Ambient Cooling

All Voyager microprocessor units have cooling capabilities down to 0°F as standard.

Low Voltage Connections

The wiring of the low voltage connections to the unit and the zone sensors is as simple as 1-1, 2-2, and 3-3. This simplified system makes it easy for the installer to wire.

Motors

All indoor fan motors are belt drive as standard.

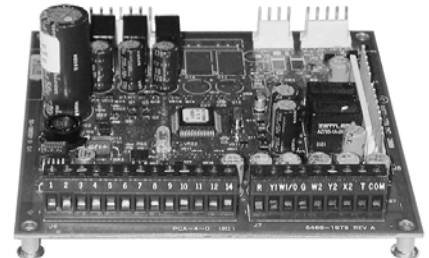

Pressure Cutouts

Low and high pressure cutouts are standard on all Voyager models.

Phase Monitor

The phase monitor provides 100% protection for motors and compressors against problems caused by phase loss, phase imbalance, and phase reversal. It is also equipped with an LED that provides an ON or FAULT indicator.

Quick-Access Panels

Remove three or fewer screws for access to the standardized internal components and wiring.

Features and Benefits

Quick-Adjust Idler Arm

With the Quick-Adjust Idler Arm (pictured right), the belt and sheaves can be quickly adjusted without moving the mounted fan motor. The result is a major savings in time and money.



Single Point Power

A single electrical connection powers the unit.

Single Side Service

Single side service is standard on all units.

Sloped Drain Pans

Standard on every unit.

Standardized Components

Components are placed in the same location on all Voyager units. Familiarize yourself with one Voyager and you are familiar with every Voyager. Due to standardized components throughout the Voyager line, contractors/owners can stock fewer parts.

U-Shaped Airflow Pattern

The U-shaped airflow allows for improved static capabilities.

Variable Frequency Drives - VFD (Multispeed Indoor Fan and SZ VAV Only)

Variable Frequency Drives are factory installed and tested to provide supply fan motor speed modulation, as well as modulating gas heat. VFDs on the supply fan, as compared to inlet guide vanes or discharge dampers, are quieter, more efficient, and are eligible for utility rebates. All VFDs are designed to allow bypass if required. Bypass control will simply provide full nominal airflow in the event of drive failure. Modulating gas heat models with VFDs allow tighter space temperature control with less temperature swing.

Variety of Options

Factory Installed Options

Black Epoxy Pre-Coated Coils

The pre-coated coils are an economical option for protection in mildly corrosive environments.

CO₂ Sensor Wiring

This unit wiring for field installed CO₂ sensors. Factory-installed CO₂ sensor wiring saves time and ensures proper unit connections for the field installed CO₂ sensor kits.

Condensate Overflow Switch

A condensate overflow switch is available to shut the unit down in the event that the condensate drain line becomes clogged. This option protects the unit from water overflowing from the drain pan and entering the base of the units.

Fault Detection & Diagnostics (FDD)

This offering meets the mandatory requirement of CA Title 24 of fully configurable diagnostics allowing fault history and reading fault codes at the unit. This option provides detection of the

following faults: Air temperature sensor failure/fault and notification of acceptable economizer mode. The FDD system shall be certified by the Energy Commission as meeting the requirements.

High Efficiency Filtration

Voyager units offer a variety of high efficiency filtration options. MERV 8 and MERV 13 filters provide additional filtration beyond the capabilities of typical 2" throwaway filters. Also, when MERV 8 or MERV 13 filters are ordered, units come equipped with a filter removal tool.

High Efficiency Motors

This option is available with efficiency ratings from 86.5 up to 91.0. It is not available for all models.

High Short Circuit Current Rating (SCCR)

Voyager rooftop units now have an optional high short circuit current rated electrical subsystem for units with an MOP above 60A. This option is a perfect fit for applications that need protection against high potential fault currents. This option also includes individual over current protection for each compressor and the indoor fan, as well as a dedicated over current protection to the condenser fan motor(s). When the high SCCR is ordered, the control box will have components separated into two sections - high and low voltage components.

Hinged Access Doors

These doors permit easy access to the filter, fan/heat, and compressor/control sections. They reduce the potential roof damage from screws or sharp access door corners.

Human Interface

The 5 inch Color Touchscreen Human Interface provides an intuitive user interface to the rooftop unit that speeds up unit commissioning, shortens unit troubleshooting times, and enhances preventative maintenance measures. The human interface includes several features such as:

- Data trending capabilities by means of time series graphs
- Historical alarm messages
- Real-time sensor measurements
- On board system setpoints
- USB port that enables the downloading of component runtime information as well as trended historical sensor data
- Customizable reports



Multi-Speed Indoor Fan System

Multi-speed indoor fan system is designed for use in applications for meeting the minimum requirement of CA Title 24. This system incorporates a multi-speed fan control to change the speed of the fan to 67% of full airflow based off compressor stages.

Powered or Unpowered Convenience Outlet

This option is a GFCI, 120V/15amp, 2-plug, convenience outlet, either powered or unpowered. This option can only be ordered when Through the Base Electrical with either the Disconnect Switch or Circuit Breaker option is ordered. This option is available on all models.

Features and Benefits

Single Zone VAV - One Zone Variable Air Volume Mode

Note: *Single Zone VAV is designed to be used with a zone sensor. If a unit is configured for Single Zone VAV operation but is connected to a thermostat, the control will revert to multi-speed (2-Speed) indoor fan control. (See "Multi-Speed Indoor Fan System" above.)*

Single Zone VAV is designed for use in single zone applications like gymnasiums, auditoriums, manufacturing facilities, retail box stores, and any large open spaces, where there is a lot of diversity in the load profile. Single Zone VAV (SZ VAV) is an ideal replacement to "yesterday's" constant volume (CV) systems, by reducing operating costs while improving occupant comfort. SZ VAV systems combine Trane application, control and system integration knowledge to exactly match fan speed with cooling and heating loads, regardless of the operating condition. Trane algorithms meet/exceed ASHRAE 90.1- 2010, SZ VAV energy-saving recommendations, and those of CA Title 24. The result is an optimized balance between zone temperature control and system energy savings. Depending on your specific application, energy savings can be as much as 20%.

Note: *Building system modeling in energy simulation software like TRACE is recommended to evaluate performance improvements for your application.*

SZ VAV is fully integrated into the ReliaTel Control system and is available today. It provides the simplest and fastest commissioning in the industry through proven factory-installed, wired, and tested system controllers. All control modules, logic and sensors are factory installed, and tested to assure the highest quality and most reliable system available. This means no special programming of algorithms, or hunting at the jobsite for sensors, boards, etc. that need to be installed in the field. Single Zone VAV is a quick and simple solution for many applications and is available from your most trusted rooftop VAV system solution provider- Trane.

Stainless Steel Drain Pan

For excellent corrosion and oxidation resistance, the optional stainless steel drain pan provides a cleanable surface that complement other IAQ solutions such as high efficiency filtration (MERV 8 or 13), and demand control ventilation (CO₂).

Supply, Return, and Plenum Air Smoke Detector

With this option (pictured right) installed, if smoke is detected, all unit operation will be shut down. Reset will be manual at the unit. Return Air Smoke Detectors require minimum allowable airflow when used with certain models.

Supply and/or Return Smoke Detectors may not be used with the Plenum Smoke Detector.



Through the Base Electrical/Horizontal Side Access with Circuit Breaker

This option is a factory installed thermal-magnetic, molded case, HACR Circuit Breaker with provisions for through the base electrical connections.

Through the Base Electrical/Horizontal Side Access with Disconnect Switch

Factory installed 3-pole, molded case, disconnect switch with provisions for through the base electrical connections are available.

Through the Base Utilities Access

An electrical service entrance shall be provided allowing electrical access for both control and main power connections inside the curb and through the base of the unit. This option will allow for field installation of liquid-tight conduit and an external, field-installed disconnect switch.

Factory or Field Installed Options

BACnet™ Communications Interface

The BACnet communications interface allows the unit to communicate directly with a generic open protocol BACnet MS/TP Network Building Automation System Controls.

Barometric Relief

Designed to be used on downflow units, barometric relief is an unpowered means of relieving excess building pressure.

Clogged Filter/Fan Failure Switch

A dedicated differential pressure switch is available to achieve active fan failure indication and/or clogged filter indication.

Discharge Air Sensing Kit

Provides true discharge air sensing in heating models. The kit is functional only with the ReliaTel™ Options Module.

Economizer - Standard, Downflow

Economizers are equipped with either dry bulb, reference, or comparative enthalpy sensing. These economizers provide free cooling as the outdoor temperature and/or humidity decreases. Correctly installed, they offer a valuable energy savings. Factory-installed economizers save time and ensure proper installation.

Note: *Factory-installed economizers require some field set-up.*

Economizer - Low Leak, Downflow

This accessory meets low leak requirements for ASHRAE 90.1, IECC, and CA Title 24 standards (3 cfm/ft²@1" wg exterior air, 4 cfm/ft²@1" wg return air). This option allows 100% outdoor air supply from 0-100% modulating dampers and is standard with barometric relief. It can be paired with powered exhaust for additional building pressure relief. This option can be paired with or without Fault Detection & Diagnostics (FDD) to meet current mandatory CA Title 24 requirements. Available on downflow units only. The economizers come with three control options, dry bulb and reference or comparative enthalpy (optional).

Electric Heaters

Electric heat modules are available within the basic unit. If ordering the Through the Base Electrical option with an Electrical Heater, the heater must be factory installed.

Frostat™

This capillary bulb embedded in the face of the evaporator coil monitors coil temperature to prevent evaporator icing and protect the compressor. Recommended for applications with low leaving air temperatures, low airflow and/or high latent load applications.

Indoor Fan Motor Shaft Grounding Ring

Shaft grounding rings are used on all VFD driven motors to provide a conductive discharge path away from the motor bearings to ground. Bearing Protection Rings shall be maintenance free circumferential rings of conductive micro fibers that discharge voltages to ground.

LonTalk® Communications Interface

The LonTalk communications interface allows the unit to communicate as a Tracer™ LCI-V device or directly with generic LonTalk Network Building Automation System Controls.

Oversized Motors

Factory or field installed oversized motors are available for high static applications.

Features and Benefits

Reference or Comparative Enthalpy

Measures and communicates humidity while maximizing comfort control.

ReliaTel Options Module (RTOM)

The RTOM monitors the supply fan proving, clogged filter, supply air temperature, exhaust fan setpoint, dehumidification setpoint, supply air tempering, Froststat™ and smoke detector.

Tool-less Hail Guards

Tool-less, hail protection quality coil guards (pictured right) shall be either factory or field-installed for condenser coil protection. This option protects the condenser coil from vandalism and/or hail damage.



Trane Communication Interface (TCI)

Available factory or field installed. This module when applied with the ReliaTel™ easily interfaces with Trane's Integrated Comfort™ System.

Field Installed Options

CO₂ Sensor - Demand Control Ventilation (DCV)

Demand-controlled ventilation (DCV) is a control strategy that responds to the actual demand (need) for ventilation by regulating the rate at which the HVAC system brings outdoor air into the building. A CO₂ sensor measures the concentration (parts per million, ppm) of CO₂ (Carbon Dioxide) in the air. As the CO₂ concentration changes, the outside air damper modulates to meet the current ventilation needs of the zone. The CO₂ sensor kit is available as a field installed accessory. Two field installed kits are offered; CO₂ sensor and wiring or CO₂ sensor only. The CO₂ Sensor only kit should be ordered with factory installed CO₂ sensor wiring. Factory installed CO₂ sensor wiring saves set-up time and ensures proper unit connections for the CO₂ sensor.

Dampers

0–25 percent manual or 0–50 percent motorized outside air dampers are available.

Digital Display Zone Sensor

The Digital LCD (Liquid Crystal Display) zone sensor has the look and functionality of standard zone sensors.

Economizer - Standard, Horizontal

Economizers are equipped with either dry bulb or reference or comparative enthalpy sensing. These economizers provide free cooling as the outdoor temperature and/or humidity decreases. Correctly installed, they offer a valuable energy savings.

Economizer - Low Leak, Downflow

This accessory meets low leak requirements for ASHRAE 90.1, IECC, and CA Title 24 standards (3 cfm/ft²@1" wg exterior air, 4 cfm/ft²@1" wg return air). This option allows 100% outdoor air supply from 0-100% modulating dampers and is standard with barometric relief. It can be paired with powered exhaust for additional building pressure relief. Available on downflow units only.

High Static Drive Accessory

Available on many models, this high static drive accessory extends the capability of the standard motor. Avoid expensive motors and operating costs by installing this optimized sheave accessory.

Powered Exhaust

This option is available on downflow units and provides exhaust of the return air, when using a downflow economizer, to maintain proper building pressurization. Great for relieving most building overpressurization problems.

Remote Potentiometer

When properly installed in the economizer control circuitry, this accessory provides a remote variable resistance to enable the operator to adjust the minimum damper position.

Roof Curbs

Available for downflow units. Only two roof curbs for the entire Voyager line simplifies curb selection.

Ventilation Override Accessory

With the Ventilation Override Accessory installed, the unit can be set to transition to up to 3 different pre-programmed sequences for Smoke Purge, Pressurization and Exhaust. The transition occurs when a binary input on the RTOM is closed (shorted). This would typically be a hard wired relay output from a smoke detector or fire control panel. The ventilation override kit is available as a field installed accessory.

Zone Sensors/Thermostats

Available in programmable, automatic and manual styles.

Note: Zone sensors required for units configured for Single Zone VAV indoor fan system control to enable Single Zone VAV functionality.

Other Benefits

Cabinet Integrity

For added water integrity, Voyager has a raised 1-1/8" lip around the supply and return of the downflow units to prevent water from blowing into the ductwork.

Easy to Install, Service and Maintain

Because today's owners are very cost-conscious when it comes to service and maintenance, Voyager was designed with direct input from service contractors. This valuable information helped to design a product that would get the serviceman off the job quicker and save the owner money. Voyager does this by offering outstanding standard features enhanced by a variety of factory and field installed options, multiple control options, rigorously tested proven designs and superior product and technical support.

Outstanding Airflow Distribution

Airflow is outstanding. The Voyager can replace an older machine with old ductwork and, in many cases, improve the comfort through better air distribution.

ReliaTel™ Controls Benefits

ReliaTel controls provide unit control for heating, cooling and ventilating by utilizing input from sensors that measure outdoor and indoor temperature.

Quality and Reliability are enhanced through ReliaTel control and logic:

- Prevents the unit from short cycling, considerably improving compressor life.
- Ensures the compressor will run for a specific amount of time which allows oil to return for better lubrication, enhancing the reliability of the compressor.

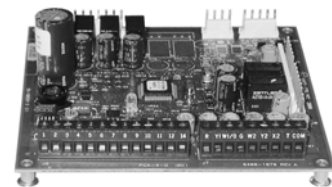



Features and Benefits

Voyager with ReliaTel reduces the number of components required to operate the unit, thereby reducing possibilities for component failure.

ReliaTel Makes Installing and Servicing Easy

ReliaTel eliminates the need for field installed anti-shortcycle timer and time delay relays.

ReliaTel controls provide these functions as an integral part of the unit. The contractor no longer has to purchase these controls as options and pay to install them. The wiring of the low voltage connections to the unit and the zone sensors is as easy as 1-1, 2-2, and 3-3. This simplified system makes wiring easier for the installer.

ReliaTel Makes Testing Easy

ReliaTel requires no special tools to run Voyager unit through its paces. Simply place a jumper between Test 1 and Test 2 terminals on the Low Voltage Terminal Board and the unit will walk through its operational steps automatically.

The unit automatically returns control to the zone sensor after stepping through the test mode a single time, even if the jumper is left on the unit.

As long as the unit has power and the "system on" LED is lit, ReliaTel is operational. The light indicates that the controls are functioning properly.

ReliaTel features expanded diagnostic capabilities when utilized with Trane Integrated Comfort™ Systems.

Some zone sensor options have central control panel lights which indicate the mode the unit is in and possible diagnostic information (dirty filters for example).

Other ReliaTel Benefits

The ReliaTel built-in anti-shortcycle timer, time delay relay and minimum "on" time control functions are factory tested to assure proper operation. ReliaTel softens electrical "spikes" by staging on fans, compressors and heaters. Intelligent Fallback is a benefit to the building occupant. If a component goes astray, the unit will continue to operate at predetermined temperature setpoint.

Intelligent Anticipation is a standard ReliaTel feature. It functions continuously as ReliaTel and zone sensor(s) work together in harmony to provide much tighter comfort control than conventional electro-mechanical thermostats.

The same ReliaTel Board fits all Packaged Gas/Electric, Cooling, and Heat Pump models. This provides standardization of parts for contractors. Less money is tied up in inventory with ReliaTel.

Rigorous Testing

All of Voyager's designs were rigorously rain tested at the factory to ensure water integrity. Voyager units incorporate either a one piece top or the Trane-Tite-Top (T3). Each part of the top (either two or three pieces) overlaps in such a way that water cannot leak into the unit. These overlapped edges are gasketed and sealed to ensure superior water integrity.

Actual shipping tests were performed to determine packaging requirements. Units were test shipped around the country to determine the best packaging. Factory shake and drop tests were used as part of the package design process to help assure that the unit arrives at the job site in top condition.

Rigging tests include lifting a unit into the air and letting it drop one foot, assuring that the lifting lugs and rails hold up under stress.

We perform a 100% coil leak test at the factory. All coils are pressure and leak tested at a minimum of 450 psig. The completely assembled refrigerant system is leak tested at a minimum of 240 psig with a refrigerant and nitrogen mixture.

All parts are inspected at the point of final assembly. Sub-standard parts are identified and rejected immediately. Every unit receives a 100 percent unit run test before leaving the production line to make sure it lives up to rigorous Trane requirements.

Unmatched Support

Trane Sales Representatives are a Support Group that can assist you with:

- Product
- Application
- Service
- Training
- Special Applications
- Specifications
- Computer Programs and much more

VariTrac

When Trane's changeover VAV System for light commercial applications is coupled with Voyager, it provides the latest in technological advances for comfort management systems and can allow thermostat control in every zone served by VariTrac.

Note: *VariTrac is not recommended for SZ VAV and Multi-speed indoor fan applications.*

VariTrac™

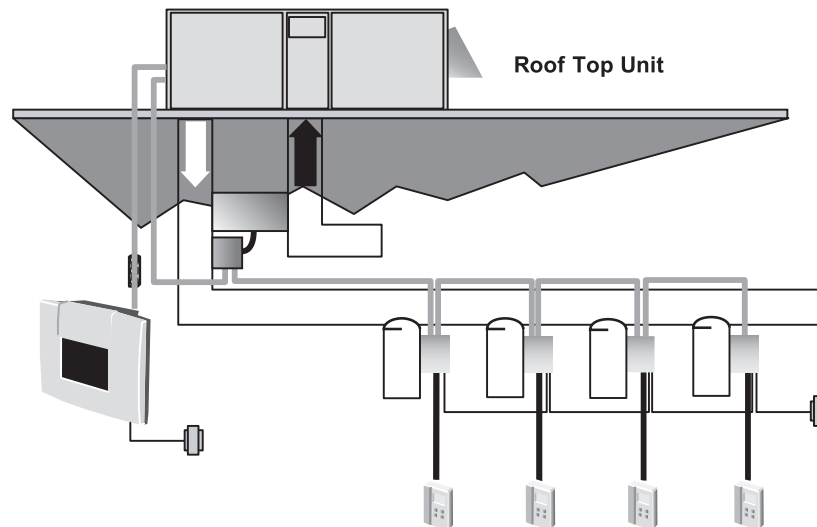



Application Considerations

Application of this product should be within the catalogued airflow and cooling considerations.

Low Ambient Cooling

This Voyager line features, as a standard, low ambient cooling down to 0°F. Contact your local Trane Representative for more assistance with low ambient cooling applications.

Barometric Relief

This product line offers an optional barometric relief damper included in the downflow economizer accessory. This accessory consists of gravity dampers which open with increased pressure. As the building air pressure increases, the pressure in the unit return air section also increases, opening the dampers and relieving the conditioned space.

Important: *THE EFFECTIVENESS OF BAROMETRIC RELIEF DAMPER DURING ECONOMIZING OPERATION IS SYSTEM RELATED. PRESSURE DROP OF THE RETURN AIR SYSTEM SHOULD BE CONSIDERED TO CONTROL BUILDING PRESSURIZATION.*

Power Exhaust Accessory

The power exhaust accessory is available on all downflow units. This accessory can be field installed and will assist in relieving a building's pressurization.

Condensate Trap

The evaporator is a draw-thru configuration. A trap must be field provided prior to start-up on the cooling cycle.

Clearance Requirements

The recommended clearances identified with unit dimensions should be maintained to assure adequate serviceability, maximum capacity and peak operating efficiency. Actual clearances which appear inadequate should be reviewed with the local Trane sales personnel.

Unit Pitch

These units have sloped condensate drain pans. Units must be installed level, any unit slope must be toward access side of unit.

VariTrac

VariTrac is not recommended for SZ VAV and Multi-speed indoor fan applications.

Selection Procedure

Cooling Capacity

Step 1

Calculate the building's total and sensible cooling loads at design conditions. Use the Trane calculation form or any other standard accepted method.

Step 2

Given the following building requirements:

- A. Electrical Characteristics: 460/60/3
- B. Summer Design Conditions: Entering Evaporator Coil: 80 DB/ 67 WB
Outdoor Ambient: 95 DB
- C. Total Cooling Load: 172 MBh
- D. Sensible Cooling Load: 122 MBh
- E. Airflow: 6000 cfm
- F. External Static Pressure: 0.50 in. w.g.
- G. Rooftop - downflow configuration.
- H. Accessories, Economizer, Supplementary Electric Heat
- I. Heating Capacity 100 MBh
460 volt/3 phase Electric Supplemental Heat - at 6000 cfm

Size the equipment using [Table 3, p. 24](#). As a starting point, a rough determination of the size of the unit must be made. This selection will then be confirmed after examining the performance at the given conditions. Divide the total cooling load by nominal BTUH per ton (12 MBh per ton); then round up to the nearest unit size. $172 \text{ MBh} / 12 \text{ MBh} = 14.33$ (approx. 15 tons.)

Step 3

[Table 3, p. 24](#) shows that a WSD180E4 has a gross cooling capacity of 186.2 MBh and 138.9 MBh sensible capacity at 95°F ambient and 6000 cfm with 80 DB/67 WB air entering the evaporator.

To Find Capacity at Intermediate Conditions

When the design conditions are between two numbers that are in the capacity table, interpolation is required to approximate the capacity.

Note: *Extrapolation outside of the table conditions is not recommended.*

Step 4

Verify that there will be enough capacity by determining net capacity. In order to select the correct unit which meets the building's requirements, the fan motor heat must be deducted from the gross cooling capacity. The amount of heat that the fan motor generates is dependent on the effort by the motor CFM and static pressure. To determine the total unit static pressure, add the following:

External Static: 0.50 in.

Standard Filter 1 in: 0.05 in. (from [Table 12, p. 29](#))

Economizer Return Air: 0.04 in. (from [Table 12, p. 29](#))

Electric Heater Size 18 kW: 0.06 in.

Total Static Pressure: 0.65 in.

Note: *The Evaporator Fan Performance [Table 6, p. 27](#) has already accounted for the pressure drop for standard filters and wet coils.*



Selection Procedure

Therefore, the actual Total Static Pressure is $0.65 - 0.05 = 0.6$. With 6000 CFM and 0.60 inches, [Table 6, p. 27](#) shows 2.17 Bhp.

The note below [Table 6, p. 27](#) gives a formula to calculate Fan Motor Heat:

$$3.15 \times \text{bhp} = \text{MBh}$$
$$3.15 \times 2.17 = 6.835 \text{ MBh}$$

Now subtracting the fan motor heat from the gross cooling capacity of the unit:

Net Total Cooling Capacity =

$$186.2 - 6.835 = 179.36 \text{ MBh}$$

Net Sensible Cooling Capacity =

$$138.9 - 6.385 = 132.065 \text{ MBh}$$

Step 5

If the performance will not meet the required load of the building, try a selection at the next higher size unit.

Heating Capacity

Step 1

Calculate the building heating load using the Trane calculation form or other standard accepted method.

Step 2

Size the equipment using [Table 14, p. 31](#) to match the heating loads at design conditions.

- A. Total Heating Load: 100 MBh
- B. Outdoor Ambient (Winter) 17 DB
- C. Indoor Return Temperature: 70 DB
- D. Airflow: 6000 CFM

Use the integrated portion of [Table 14, p. 31](#) for the WSD180E4 to determine capacity at winter design conditions. The mechanical heating portion of the heat pump will provide 85.4 MBh.

Step 3

Because 45 MBh is less than the building's required heating capacity at winter design conditions, a supplementary heater must be selected.

$$100.0 - 85.54 = 14.46 \text{ MBh}$$

From [Table 17, p. 32](#), at 480 volts, the 18 kW Heater will be adequate to do the job.

$$18 \text{ kW} \quad 61 \text{ MBh}$$

From [Table 17, p. 32](#) select heater AYDHTRK418A (18 kW 460/60/3).

Model Number Description

W	S	D	1	5	0	E	3	R	G	B	*	*
1	2	3	4	5	6	7	8	9	10	11	12	13
Digit 1 – Unit Type			7 = Multi-Speed Standard Motor			Digit 22 – Refrigeration System Option			0 = Standard refrigeration system			
W = Packaged Cooling, Electric Heat			8 = Single Zone Variable Air Volume Oversized Motor			Digit 23 – Refrigeration Controls			0 = Without Refrigeration Controls			
Digit 2 – Efficiency			9 = Multi-Speed Oversized Motor			A = Single Zone Variable Air Volume Standard Motor w/ Shaft Ground Ring			1 = Frostat™			
S = Standard Efficiency			A = Single Zone Variable Air Volume Standard Motor w/ Shaft Ground Ring			Digit 24 – Smoke Detector^{2,9}			0 = Without Smoke Detector			
Digit 3 – Airflow Configuration			B = Multi-Speed Standard Motor w/ Shaft Ground Ring			C = Single Zone Variable Air Volume Oversized Motor w/ Shaft Ground Ring			A = Return Air Smoke Detector			
D = Downflow			C = Single Zone Variable Air Volume Oversized Motor w/ Shaft Ground Ring			D = Multi-Speed Oversized Motor w/ Shaft Ground Ring			B = Supply Air Smoke Detector			
H = Horizontal			Digit 16 – Hinged Service Access / Filters⁵			Digit 25 – System Monitoring Controls²			C = Return/Supply Air Smoke Detector			
Digit 4, 5, 6 – Nominal Gross Cooling Capacity (MBh)			0 = Standard Panels/Standard Filters ¹⁷			A = Hinged Access/Standard Filters ¹⁷			D = Plenum Smoke Detector			
150 = 12½ Tons			A = Hinged Access/Standard Filters ¹⁷			B = Standard Panels/2" MERV 8 Filters			Digit 25 – System Monitoring Controls²			
180 = 15 Tons			B = Standard Panels/2" MERV 8 Filters			C = Hinged Access/2" MERV 8 Filters			0 = No Monitoring Controls			
240 = 20 Tons			C = Hinged Access/2" MERV 8 Filters			D = Standard Panels/MERV 13 Filters			1 = Clogged Filter Switch			
Digit 7 – Major Design Sequence			D = Standard Panels/MERV 13 Filters			E = Hinged Access/MERV 13 Filters			2 = Fan Failure Switch			
E = R-410A Refrigerant			Digit 17 – Condenser Coil Protection			0 = Standard Coil			3 = Discharge Air Sensing			
Digit 8 – Voltage Selection			1 = Standard Coil With Hail Guard			1 = Standard Coil With Hail Guard			4 = Clogged Filter Switch and Fan Failure			
3 = 208-230/60/3			2 = Black Epoxy Pre-Coated Coil			2 = Black Epoxy Pre-Coated Coil			5 = Clogged Switch and Discharge Air Sensing			
4 = 460/60/3			3 = Black Epoxy Pre-Coated Coil with Hail Guard			3 = Black Epoxy Pre-Coated Coil with Hail Guard			6 = Fan Failure Switch and Discharge Air Sensing			
W = 575/60/3			Digit 18 – Through The Base Provisions			0 = No Through The Base Provisions			7 = Clogged Filter Switch, Fan Failure Switch and Discharge Air Sensing			
Digit 9 – Unit Controls			A = Through The Base Electric ¹¹			A = Through The Base Electric ¹¹			A = Condensate Drain Pan Overflow Switch			
R = Reliatel			D = Through The Base Utilities Access			D = Through The Base Utilities Access			B = Clogged Filter Switch and Condensate Drain Pan Overflow Switch			
Digit 10 – Heating Capacity			Digit 19 – Disconnect Switch/ Circuit Breaker¹⁰			0 = No Disconnect/circuit break			C = Fan Failure Switch and Condensate Drain Pan Overflow Switch			
0 = No Heat			0 = No Disconnect/circuit break			1 = Unit Mounted Non-Fused Disconnect Switch			D = Discharge Air Sensing and Condensate Drain Pan Overflow Switch			
G = 18 kW Electric Heat			1 = Unit Mounted Non-Fused Disconnect Switch			2 = Unit Mounted Circuit Breaker			E = Clogged Filter Switch, Fan Failure Switch and Condensate Drain Pan Overflow Switch			
N = 36 kW Electric Heat			2 = Unit Mounted Circuit Breaker			Digit 20 – Convenience Outlet Option			F = Clogged Filter Switch, Discharge Air Sensing Tube and Condensate Drain Pan Overflow Switch			
P = 54 kW Electric Heat			Digit 20 – Convenience Outlet Option			0 = Without Convenience Outlet			G = Fan Failure Switch, Discharge Air Sensing Tube and Condensate Drain Pan Overflow Switch			
R = 72 kW Electric Heat			0 = Without Convenience Outlet			A = Unpowered Convenience Outlet ⁴			H = Clogged Filter Switch, Fan Failure Switch, Discharge Air Sensing and Condensate Drain Pan Overflow Switch			
Digit 11 – Minor Design Sequence			A = Unpowered Convenience Outlet ⁴			B = Powered Convenience Outlet ⁴			Digit 26 - System Monitoring Controls			
Digit 12, 13 – Service Sequence			B = Powered Convenience Outlet ⁴			Digit 21 – Communications Options			0 = No Monitoring Controls			
Digit 14 – Fresh Air Selection			0 = Without Communications Options			0 = Without Communications Options			A = Demand Control Ventilation (CO ₂) ¹⁵			
0 = No Fresh Air			1 = Trane Communications Interface ^{5, 13}			1 = Trane Communications Interface ^{5, 13}			B = FDD (Fault Detection and Diagnostics)			
A = Manual Damper			2 = Lontalk Communications Interface ⁵			2 = Lontalk Communications Interface ⁵						
B = Motorized Damper			6 = Building Automation Control Network Communications Interface			6 = Building Automation Control Network Communications Interface						
D = Econ Dry Bulb w/ Barometric Relief ¹												
F = Econ Reference Enthalpy w/ Barometric Relief ¹												
H = Econ Comparative Enthalpy w/ Barometric Relief ¹												
K = Low Leak Econ w/ Barometric Relief ¹												
M = Low Leak Econ Reference Enthalpy w/ Barometric Relief ¹												
P = Low Leak Econ Comparative Enthalpy w/ Barometric Relief ¹												
Digit 15 – Supply Fan/Drive Type/Motor												
0 = Standard Motor												
1 = Oversized Motor ⁵												
3 = High Efficiency Motor ⁵												
6 = Single Zone Variable Air Volume Standard Motor												



Model Number Description

C = FDD (Fault Detection Diagnostics) & Demand Control Ventilation (CO₂)¹⁵

Digit 27 - Unit Hardware Enhancements

0 = No Enhancements
1 = Stainless Steel Drain Pan

Digit 28 - Short Circuit Current Rating

0 = Standard SCCR
A = 65kA SCCR Option¹⁶

Digit 31 - Advanced Unit Controls

0 = Standard Unit Controls
1 = Human Interface¹⁸

Note: *Most Factory Installed Options available for Downflow Air Discharge units only. Please verify with ordering system for availability.*

Model Number Notes

1. Some field set up required.
2. Requires ReliaTel Options Module.
3. Requires Economizer.
4. Must be ordered with Through-the-Base Electrical option or Horizontal-Side Access and either Unit Mounted Disconnect or Circuit Breaker.
5. Available factory installed on downflow AND horizontal units. Verify with ordering system.
6. Cannot be fused.
7. Must be factory installed when using Through-the-Base Options.
8. ReliaTel Options Module is required when ordering the following accessories: Clogged Filter Switch, Fan Fail Switch, Condensate Overflow Switch, Discharge Air Sensing Kit, Froststat, Ventilation Override, and Smoke Detector.
9. Option cannot be ordered in conjunction with field installed economizer on downflow units. Must be factory installed. The return air smoke detector may not fit up or work properly on the Voyager units when used in conjunction with 3rd party accessories (such as bolt on heat wheels, economizers, and power exhaust). Do not order the return air smoke detectors when using this type of accessory.
10. Unit mounted disconnect and circuit breakers are mutually exclusive of each other.
11. Through-the-base electrical option or Horizontal-Side Access must be ordered with either unit mounted disconnect or circuit breaker. When adding heat, you must order Trane Electric Heat.
12. All Factory Installed Options are Built-to-Order. Check order services for estimated production cycle.
13. TCI is for use with non-VariTrac systems and VariTrac systems.
14. For use with multi-speed and SZVAV units only.
15. Demand Control Ventilation Option includes wiring only. The CO₂ sensor is a field-installed only option.
16. 575 VAC option is 25kA.
17. Standard filters are not available with Low Leak Economizers.
18. Human Interface is standard with FDD (Fault Detection Diagnostics).

General Data

Table 1. General data — 12½ - 20 tons

	12½ Tons Downflow & Horizontal Units	15 Tons Downflow & Horizontal Units	20 Tons Downflow & Horizontal Units
	WS*150E3,4,W	WS*180E3,4,W	WS*240E3,4,W
Cooling Performance^(a)			
Gross Cooling Capacity	148,000	177,000	249,000
EER ^(b)	10.6	10.6	9.7
Nominal Airflow/ARI Rated Airflow (CFM)	5000	6000 / 5300	8000 / 6400
ARI Net Cooling Capacity	146,000	170,000	240,000
IEER ^(c) (One Speed Fan / Two or Variable Speed Fan)	12/13.5	12/13.5	11.5/12.0
System Power (kW)	13.77	16.04	25.47
Heating Performance^(a)			
High Temp. Btuh Rating	136,000	170,000	210,000
COP	3.2	3.2	3.2
System Power (kW)	12.46	15.57	19.23
Low Temp. Btuh Rating	75,000	90,000	120,000
COP	2.1	2.1	2.1
System Power (kW)	10.47	12.56	16.75
Compressor			
Number/Type	2 / Scrolls	2 / Scrolls	2 / Scrolls
ARI Sound Rating (BELS)^(d)			
	9.2	9.2	9.4
Outdoor Coil — Type			
Refrigerant Control	Hi-Performance Expansion Valve	Hi-Performance Expansion Valve	Hi-Performance Expansion Valve
Tube Size (in.) OD	0.3125	0.3125	0.3125
Face Area (sq. ft.)	35.20	35.20	42.53
Rows/FPI	3 / 16	3 / 16	3 / 16
Indoor Coil — Type			
Tube Size (in.) ID	Hi-Performance 0.3125	Hi-Performance 0.3125	Hi-Performance 0.3125
Face Area (sq. ft.)	26.00	26.00	31.42
Rows/FPI	3 / 15	4 / 15	4 / 15
Refrigerant Control	Short Orifice	Short Orifice	Short Orifice
Drain Connection Number/Size (in.)	1/1.00 NPT	1/1.00 NPT	1/1.00 NPT
Outdoor Fan — Type			
Number Used/Diameter (in.)	Propeller 2 / 26	Propeller 2 / 26	Propeller 2 / 28
Drive Type/No. Speeds	Direct / 1	Direct / 1	Direct / 1
CFM	11,100	10,800	14,800
Number Motors/HP	2 / 0.5	2 / 0.5	2 / 1.0
Motor RPM	1,100	1,100	1,125



General Data

Table 1. General data – 12½ - 20 tons (continued)

	12½ Tons Downflow & Horizontal Units	15 Tons Downflow & Horizontal Units	20 Tons Downflow & Horizontal Units
	WS* 150E3,4,W	WS* 180E3,4,W	WS* 240E3,4,W
Indoor Fan - Type	FC Centrifugal	FC Centrifugal	FC Centrifugal
Number Used/Diameter (in.)	1 / 18x18	1 / 18x18	1 / 18x18
Drive Type/No. Speeds	Belt / 1	Belt / 1	Belt / 1
Number Motors	1	1	1
Motor HP (Standard/Oversized)	3.0 / 5.0	3.0 / 5.0	5.0 / 7.5
Motor RPM (Standard/Oversized)	1740 / 3,450	1740 / 3,450	3450 / 3,470
Motor Frame Size (Standard/Oversized)	145T / 145T	145T / 145T	145T / 184T
Filters - Type Furnished	Throwaway	Throwaway	Throwaway
Number Size Recommended			
Downflow	(4)20x20x2	(4)20x20x2	(8)20x20x2
	(4)20x25x2	(4)20x25x2	(4)20x16x2
Horizontal	(8)20x25x2	(8)20x25x2	(12)20x20x2
Refrigerant Charge Pounds of R-410A^(e)			
Downflow	14 / 14.5	16.5 / 15.9	20.0 / 20.7
Horizontal	13.2 / 13.3	17 / 15.9	

(a) Cooling Performance is rated at 35°C (95°F) ambient, 26.7°C (80°F) entering dry bulb, 19.4°C (67°F) entering wet bulb. Heating Performance is rated at 20°C (68°F) ambient, 8.3°C (47°F) entering dry bulb, 6.1°C (43°F) entering wet bulb.

Gross capacity does not include the effect of fan motor heat. ARI capacity is net and includes the effect of fan motor heat. Units are suitable for operation to ±20% of nominal airflow. Rated in accordance with ARI Standard 210/240 or 340/360.

(b) EER is rated at ARI conditions and in accordance with DOE test procedures.

(c) Integrated Energy Efficiency Ratio (IEER) is rated in accordance with AHRI standard 210/240 or 360.

(d) Sound Rating shown is tested in accordance with ARI Standard 270 or 370.

(e) Refrigerant charge is an approximate value. For a more precise value, see unit nameplate and service instructions.



Performance Data

Table 2. Gross cooling capacities (MBh) 12½ tons three phase WS*150E

Air Flow CFM	Ent DB °F	Ambient Temperature (°F)																	
		85						95						105					
		Entering Wet Bulb (F)																	
		61		67		73		61		67		73		61		67		73	
MBH	SHC	MBH	SHC	MBH	SHC	MBH	SHC	MBH	SHC	MBH	SHC	MBH	SHC	MBH	SHC	MBH	SHC		
4000	75	140.4	110.8	152.3	74.7	156.2	39.1	131.7	108.1	146.6	75.2	153.1	35.5	118.1	103.1	138.7	73.6	148.3	33.9
	80	146.6	139.5	156.7	99.7	160.5	60.9	135.0	131.4	148.6	98.4	155.7	59.5	123.4	123.4	140.6	97.0	150.9	58.0
	85	148.1	148.1	156.5	121.3	161.4	85.3	141.9	141.9	150.7	121.6	158.5	83.4	135.0	135.0	142.6	120.3	153.1	81.9
	90	155.8	155.8	159.4	144.5	163.7	106.3	150.5	150.5	153.8	145.1	160.6	107.3	144.0	144.0	146.2	143.6	156.0	105.8
4500	75	144.5	117.5	156.4	77.9	157.1	37.5	136.4	115.5	149.0	77.1	154.1	36.7	125.1	111.9	141.7	76.3	149.6	33.1
	80	147.8	143.2	158.8	103.5	159.8	61.1	139.9	139.6	151.2	102.9	157.1	63.3	131.5	131.5	143.7	102.3	152.3	60.1
	85	153.8	153.8	158.8	127.9	162.4	85.0	148.2	148.2	153.8	128.8	159.9	89.0	141.3	141.3	146.4	129.1	155.0	86.6
	90	160.1	160.1	161.6	152.9	165.3	108.6	156.0	156.0	157.4	153.7	162.5	113.9	150.0	150.0	150.9	150.8	157.6	113.0
5000	75	147.7	123.7	154.9	78.7	157.8	33.9	139.8	122.3	150.7	78.4	154.7	36.9	129.6	119.6	143.9	79.1	150.9	33.7
	80	151.6	150.4	160.1	107.3	160.2	60.0	144.2	144.2	153.1	107.3	158.0	64.7	136.9	136.9	146.1	107.3	153.1	63.5
	85	157.3	157.3	160.3	135.3	162.7	86.8	152.6	152.6	156.4	136.0	160.8	91.1	146.2	146.2	149.3	136.4	156.5	92.2
	90	162.3	162.3	163.0	158.0	165.4	112.7	159.4	159.4	159.9	159.1	163.6	116.5	154.2	154.2	154.2	154.2	159.3	120.2
5500	75	149.9	129.7	155.6	82.5	158.0	31.8	142.5	128.7	151.9	80.6	155.5	34.1	133.3	126.6	145.6	81.1	153.0	36.3
	80	154.1	154.0	158.4	112.6	160.5	62.6	148.3	148.3	154.5	111.6	158.7	63.3	141.2	141.2	148.2	112.6	154.5	66.6
	85	159.4	159.4	161.0	140.5	163.3	91.2	155.8	155.8	157.9	142.7	160.9	90.9	150.0	150.0	151.8	143.2	157.3	96.9
	90	163.8	163.8	164.2	160.8	165.7	118.4	161.1	161.1	161.4	161.2	164.1	119.0	157.1	157.1	157.2	157.2	160.3	125.5
6000	75	153.7	136.6	156.6	85.7	159.3	32.9	145.0	134.8	152.1	83.2	155.8	31.7	136.2	132.9	147.0	83.8	151.9	35.3
	80	156.4	156.4	159.2	116.6	161.8	65.1	151.2	151.2	155.4	116.6	159.2	63.2	144.6	144.6	149.8	117.7	155.3	68.4
	85	160.3	160.3	161.9	143.5	163.7	95.1	157.8	157.8	159.0	148.8	164.6	97.9	152.7	152.7	156.1	154.1	158.2	99.2
	90	164.7	164.7	164.9	162.7	166.3	122.2	162.7	162.7	164.7	164.7	164.5	123.4	158.7	158.7	158.6	158.6	161.3	128.5
Air Flow CFM	Ent DB °F	Ambient Temperature (°F)																	
		115																	
		Entering Wet Bulb (F)																	
		61		67		73		61		67		73		61		67		73	
MBH	SHC	MBH	SHC	MBH	SHC	MBH	SHC	MBH	SHC	MBH	SHC	MBH	SHC	MBH	SHC	MBH	SHC		
4000	75	104.6	98.2	129.1	71.4	141.4	33.8												
	80	114.1	114.1	130.8	94.5	143.9	58.3												
	85	127.1	127.1	132.8	118.1	145.8	82.1												
	90	136.7	136.7	136.9	136.9	148.1	105.6												
4500	75	111.4	107.2	132.2	74.6	143.0	32.2												
	80	122.5	122.5	134.1	100.7	145.4	59.5												
	85	133.6	133.6	137.3	127.3	147.8	85.6												
	90	142.8	142.8	142.9	142.9	150.6	112.4												
5000	75	116.2	114.7	134.8	77.8	144.4	31.3												
	80	128.8	128.8	136.9	106.9	146.7	60.7												
	85	138.6	138.6	140.6	135.6	149.5	90.1												
	90	147.3	147.3	147.5	147.5	152.6	119.3												
5500	75	121.4	121.1	136.7	80.5	144.9	32.0												
	80	133.0	133.0	139.2	112.5	148.0	63.8												
	85	142.5	142.5	143.5	142.0	150.9	95.4												
	90	150.4	150.4	150.5	150.5	153.8	126.7												
6000	75	125.5	125.5	138.4	83.4	145.6	32.6												
	80	136.5	136.5	141.1	117.9	148.8	66.6												
	85	145.6	145.6	146.1	145.9	151.8	100.4												
	90	152.7	152.7	152.6	152.6	155.0	132.6												

Notes:
 1. Dry Coil Condition. Total Gross Cooling Capacity (MBh) shown to the left is not applicable. In this case the Sensible Heat Capacity (SHC) is the total capacity.
 2. All capacities shown are gross and have not considered indoor fan heat. To obtain net cooling subtract indoor fan heat.
 3. MBH = Total Gross Capacity
 4. SHC = Sensible Heat Capacity
 * stands for both downflow and horizontal unit.



Performance Data

Table 3. Gross cooling capacities (MBh) 15 tons three phase WS*180E

Air Flow CFM	Ent DB °F	Ambient Temperature (°F)																	
		85						95						105					
		Entering Wet Bulb (F)																	
		61		67		73		61		67		73		61		67		73	
MBH	SHC	MBH	SHC	MBH	SHC	MBH	SHC	MBH	SHC	MBH	SHC	MBH	SHC	MBH	SHC	MBH	SHC		
4800	75	172.4	137.8	185.0	97.2	190.7	51.2	157.4	132.2	181.5	98.1	189.5	52.1	141.1	123.6	169.8	95.1	185.3	54.1
	80	175.2	164.2	185.9	124.4	191.5	73.3	165.6	159.0	182.5	125.2	190.5	80.5	151.3	150.2	179.0	126.0	186.2	82.1
	85	182.7	182.4	204.9	161.7	192.5	98.7	176.3	176.3	183.4	152.4	190.9	107.9	167.0	167.0	161.9	143.1	187.8	110.5
	90	186.4	187.2	188.2	173.6	192.9	123.3	185.2	185.2	186.8	175.9	191.9	134.5	178.6	178.6	180.1	173.1	188.8	137.3
5400	75	176.7	146.7	186.4	97.4	192.2	43.3	163.9	141.3	183.8	102.8	190.8	53.1	148.9	134.8	174.0	99.6	187.4	51.8
	80	185.0	177.6	187.1	128.6	192.7	68.8	173.2	169.4	185.4	133.4	191.9	82.7	161.4	161.2	175.2	130.2	188.4	82.7
	85	185.9	186.3	188.2	157.9	193.7	99.4	183.4	183.4	186.4	163.3	192.8	110.9	171.2	171.2	178.2	160.1	188.9	112.5
	90	189.2	190.2	189.9	181.4	193.9	129.3	188.2	188.7	188.9	182.3	193.7	138.7	183.8	183.8	185.0	181.5	190.0	143.1
6000	75	180.7	154.7	186.9	103.2	193.2	37.0	169.6	151.6	186.2	105.9	192.0	51.1	154.9	143.9	177.5	103.9	189.4	51.7
	80	184.3	179.0	193.7	140.1	193.9	70.8	179.0	177.4	186.2	138.9	193.4	81.3	163.3	163.3	178.8	137.7	190.0	85.0
	85	187.7	188.5	189.9	165.8	194.6	104.4	186.5	186.5	188.1	168.9	194.3	111.2	171.3	172.9	182.7	169.1	190.4	119.4
	90	191.3	192.2	191.6	184.4	194.5	135.3	190.5	191.3	190.7	187.4	195.1	140.8	187.5	187.7	187.4	186.9	191.8	152.7
6600	75	189.8	168.9	188.4	106.3	193.8	36.5	175.1	160.4	186.7	106.8	193.3	46.9	160.4	151.9	180.2	109.6	189.7	51.0
	80	185.9	182.8	189.6	140.4	194.2	73.1	182.9	182.6	195.4	150.8	194.5	77.7	152.3	152.3	181.8	146.4	190.7	88.8
	85	188.8	189.7	190.9	168.8	195.1	108.9	188.3	188.7	189.2	174.2	195.3	110.6	181.0	181.0	185.1	175.2	191.4	125.5
	90	192.3	193.5	192.7	186.1	195.8	141.0	191.3	192.3	192.4	191.2	196.0	145.8	189.6	190.1	189.5	190.0	192.9	158.2
7200	75	184.1	166.8	189.6	107.7	193.7	36.2	177.0	165.0	187.4	110.1	194.3	40.6	165.9	159.8	185.2	112.5	191.1	51.1
	80	187.8	187.0	190.5	141.8	194.6	73.2	185.5	185.5	188.5	148.8	195.4	76.1	156.3	157.7	183.6	152.6	191.9	91.6
	85	190.2	191.0	191.1	170.0	195.6	113.4	189.8	190.4	190.4	180.2	196.5	115.6	186.6	186.6	187.3	180.0	192.9	129.7
	90	193.5	194.7	193.5	190.5	196.5	145.2	193.2	194.0	194.0	193.4	196.2	152.3	191.5	192.2	191.4	192.1	194.0	161.4
Air Flow CFM	Ent DB °F	Ambient Temperature (°F)																	
		115																	
		Entering Wet Bulb (F)																	
		61		67		73		61		67		73		61		67		73	
MBH	SHC	MBH	SHC	MBH	SHC	MBH	SHC	MBH	SHC	MBH	SHC	MBH	SHC	MBH	SHC	MBH	SHC		
4000	75	125.9	115.6	153.3	88.3	177.8	55.8												
	80	137.6	137.6	154.4	115.9	179.0	83.1												
	85	154.5	154.5	158.9	143.5	179.8	110.1												
	90	168.6	168.6	169.3	167.4	180.8	137.7												
4500	75	132.7	125.6	158.2	94.1	180.4	54.5												
	80	147.7	147.7	159.7	125.2	181.4	84.8												
	85	164.1	164.1	166.5	155.1	182.2	116.3												
	90	176.1	176.1	176.4	176.3	183.2	146.8												
5000	75	139.5	135.4	162.3	99.8	182.0	52.6												
	80	155.6	155.6	164.6	134.3	182.9	87.6												
	85	170.4	170.4	171.8	163.3	183.6	121.0												
	90	180.9	180.9	180.9	180.9	184.7	153.1												
5500	75	145.6	143.4	165.6	104.6	183.0	51.6												
	80	162.2	162.2	168.3	142.1	183.9	89.0												
	85	175.2	175.2	176.2	170.7	184.8	126.0												
	90	184.1	184.1	184.2	184.2	186.5	161.7												
6000	75	150.4	149.6	168.3	108.5	184.1	51.5												
	80	167.2	167.2	171.0	148.6	184.8	93.7												
	85	179.5	179.5	179.9	177.1	186.0	132.8												
	90	185.5	185.7	186.3	186.4	187.8	168.8												

Notes:

1. Dry Coil Condition. Total Gross Cooling Capacity (MBh) shown to the left is not applicable. In this case the Sensible Heat Capacity (SHC) is the total capacity.
 2. All capacities shown are gross and have not considered indoor fan heat. To obtain net cooling subtract indoor fan heat.
 3. MBH = Total Gross Capacity
 4. SHC = Sensible Heat Capacity
- * stands for both downflow and horizontal unit.

Performance Data

Table 4. Gross cooling capacities (MBh) 20 tons three phase WS*240E

Air Flow CFM	Ent DB °F	Ambient Temperature (°F)																													
		85						95						105																	
		Entering Wet Bulb (F)																													
		61			67			73			61			67			73			61			67			73					
MBH	SHC	MBH	SHC	MBH	SHC	MBH	SHC	MBH	SHC	MBH	SHC	MBH	SHC	MBH	SHC	MBH	SHC	MBH	SHC	MBH	SHC	MBH	SHC	MBH	SHC	MBH	SHC	MBH	SHC		
6400	75	231.1	183.1	268.4	137.9	289.8	77.1	208.1	173.6	253.0	133.2	279.2	76.0	183.1	163.6	232.4	126.5	264.7	75.0												
	80	235.6	220.5	270.5	174.4	293.4	114.9	213.9	209.8	254.8	169.7	282.0	114.4	194.5	194.4	233.8	162.8	266.8	111.7												
	85	247.9	247.9	273.1	211.7	297.1	153.0	233.1	233.1	256.8	206.6	284.9	152.1	217.4	217.4	236.3	199.8	269.0	149.2												
	90	266.0	266.0	276.3	249.1	300.8	190.8	253.6	253.6	260.8	244.3	288.0	189.7	238.1	238.1	241.6	236.3	271.5	186.7												
7200	75	242.5	197.1	274.8	142.3	292.9	73.3	219.0	187.9	259.9	138.5	283.2	74.2	194.4	178.4	239.9	132.8	269.1	72.5												
	80	247.6	238.6	277.5	183.8	297.1	115.8	227.3	226.2	261.8	179.8	286.4	115.6	209.7	209.7	241.8	174.2	271.7	114.5												
	85	262.8	262.8	280.9	225.7	301.5	158.1	248.8	248.8	265.0	221.7	290.1	158.4	233.0	233.0	245.7	216.1	274.7	156.5												
	90	279.8	279.8	286.0	268.1	305.8	200.4	267.3	267.3	270.9	263.1	294.0	200.7	253.1	253.1	254.3	253.2	278.1	199.5												
8000	75	251.1	209.8	279.7	146.5	295.4	70.6	229.7	202.0	265.1	143.6	285.9	70.7	204.3	192.2	247.0	139.0	272.5	70.2												
	80	258.3	254.4	283.0	192.7	299.9	117.4	240.8	240.6	267.8	189.7	289.8	117.8	222.4	222.4	249.6	185.1	275.6	117.0												
	85	274.0	274.0	287.2	239.1	304.5	164.0	260.7	260.7	271.9	236.4	294.0	164.5	245.2	245.2	253.4	231.5	279.0	163.6												
	90	290.9	290.9	293.8	284.4	309.4	210.2	278.4	278.4	279.8	277.3	298.5	210.9	263.8	263.8	264.2	264.2	283.2	210.9												
8800	75	258.4	222.0	283.4	150.7	297.2	69.0	237.8	214.9	269.4	148.5	288.1	69.4	212.9	204.9	251.4	144.7	275.1	69.2												
	80	266.2	265.3	287.2	201.2	302.1	120.4	251.2	251.2	272.7	199.1	292.5	120.1	233.8	233.8	254.5	195.4	278.7	120.1												
	85	283.3	283.3	292.2	251.8	307.1	170.5	270.0	270.0	277.7	250.1	296.9	170.3	254.9	254.9	260.0	246.0	282.6	171.1												
	90	298.9	298.9	300.3	296.3	312.4	219.9	287.3	287.3	288.0	287.6	302.1	221.9	273.0	273.0	273.3	273.3	287.4	222.7												
9600	75	263.4	233.2	286.3	154.9	298.8	68.8	243.6	226.7	272.9	153.4	289.9	67.5	220.3	216.0	255.4	150.4	277.1	68.5												
	80	273.7	273.6	290.6	209.2	303.9	123.4	259.6	259.6	276.6	208.6	294.5	123.2	242.4	242.4	258.5	205.2	281.0	123.0												
	85	290.4	290.4	296.3	263.8	309.1	176.8	277.9	277.9	282.6	263.4	299.2	177.8	262.7	262.7	265.5	258.0	285.3	178.3												
	90	304.8	304.8	305.5	304.1	314.5	229.2	294.2	294.2	294.4	294.4	304.9	232.6	280.3	280.3	280.6	280.6	290.7	234.1												
Air Flow CFM	Ent DB °F	Ambient Temperature (°F)																													
		115																													
		Entering Wet Bulb (F)																													
		61			67			73			61			67			73			61			67			73					
MBH	SHC	MBH	SHC	MBH	SHC	MBH	SHC	MBH	SHC	MBH	SHC	MBH	SHC	MBH	SHC	MBH	SHC	MBH	SHC	MBH	SHC	MBH	SHC	MBH	SHC	MBH	SHC	MBH	SHC		
6400	75	158.5	152.9	206.9	118.1	246.1	71.0																								
	80	177.1	177.1	208.6	154.5	247.1	108.6																								
	85	201.1	201.1	212.3	192.1	249.1	144.9																								
	90	222.0	222.0	223.1	223.0	251.3	182.3																								
7200	75	168.6	165.4	216.4	125.7	251.0	70.1																								
	80	191.7	191.7	218.4	166.8	252.7	111.5																								
	85	214.8	214.8	223.1	209.0	255.1	153.3																								
	90	236.2	236.2	236.5	236.5	257.9	195.5																								
8000	75	179.2	177.5	223.0	132.4	254.7	68.8																								
	80	204.0	204.0	225.4	178.2	257.0	115.2																								
	85	227.3	227.3	230.9	223.5	259.6	161.8																								
	90	247.3	247.3	247.7	247.7	263.3	208.7																								
8800	75	188.7	188.1	227.6	138.7	257.4	67.5																								
	80	214.2	214.2	230.3	189.1	260.3	118.2																								
	85	237.3	237.3	239.4	236.4	263.6	170.1																								
	90	256.1	256.1	256.3	256.3	267.8	221.7																								
9600	75	197.1	197.0	231.8	145.0	259.8	67.1																								
	80	223.4	223.4	235.9	200.1	262.9	122.0																								
	85	245.1	245.1	246.0	245.3	266.7	178.3																								
	90	263.4	263.4	263.6	263.6	271.7	234.3																								

Notes:

1. Dry Coil Condition. Total Gross Cooling Capacity (MBh) shown to the left is not applicable. In this case the Sensible Heat Capacity (SHC) is the total capacity.
2. All capacities shown are gross and have not considered indoor fan heat. To obtain net cooling subtract indoor fan heat.
3. MBH = Total Gross Capacity
4. SHC = Sensible Heat Capacity

* stands for both downflow and horizontal unit.



Performance Data

Table 5. Evaporator fan performance 12½ tons WS*150E downflow or horizontal

External Static Pressure (Inches of Water)																					
		0.10		0.20		0.30		0.40		0.50		0.60		0.70		0.80		0.90		1.00	
CFM	RPM	BHP	RPM	BHP	RPM	BHP	RPM	BHP	RPM	BHP	RPM	BHP	RPM	BHP	RPM	BHP	RPM	BHP	RPM	BHP	
3HP Standard Motor & Low Static Drive Accessory											3HP Standard Motor & Drive										
4000	—	—	382	0.56	420	0.66	459	0.79	496	0.91	531	1.05	564	1.19	595	1.34	625	1.50	654	1.67	
4500	—	—	410	0.73	446	0.85	479	0.97	514	1.11	548	1.26	578	1.40	610	1.56	639	1.72	666	1.89	
5000	400	0.80	440	0.95	473	1.07	504	1.20	534	1.34	566	1.50	597	1.66	625	1.81	653	1.98	681	2.16	
5500	431	1.03	470	1.19	502	1.34	531	1.48	559	1.62	586	1.77	615	1.95	643	2.12	670	2.30	695	2.47	
6000	463	1.30	500	1.48	531	1.65	559	1.80	585	1.95	611	2.11	636	2.28	662	2.46	689	2.66	714	2.85	
											3HP Standard Motor & High Static Drive Accessory										
Continued																					
External Static Pressure (Inches of Water)																					
		1.10		1.20		1.30		1.40		1.50		1.60		1.70		1.80		1.90		2.00	
CFM	RPM	BHP	RPM	BHP	RPM	BHP	RPM	BHP	RPM	BHP	RPM	BHP	RPM	BHP	RPM	BHP	RPM	BHP	RPM	BHP	
3HP Standard Motor & Low Static Drive Accessory											3HP Standard Motor & High Static Drive Accessory										
4000	682	1.83	708	1.99	734	2.16	758	2.32	782	2.49	804	2.66	826	2.83	847	3.01	867	3.19	886	3.38	
4500	693	2.07	719	2.25	745	2.44	769	2.62	793	2.80	815	2.99	838	3.17	859	3.36	880	3.55	900	3.74	
5000	707	2.34	732	2.53	757	2.72	780	2.92	804	3.13	826	3.33	848	3.54	870	3.74	891	3.95	911	4.15	
5500	721	2.66	747	2.86	771	3.05	794	3.26	816	3.46	838	3.68	860	3.90	881	4.13	902	4.36	922	4.58	
6000	738	3.04	760	3.22	784	3.43	808	3.65	831	3.86	852	4.08	873	4.30	893	4.53	913	4.77	933	5.01	
											5HP Oversized Motor & Drive										

Notes:

1. Fan motor heat (MBH) = 3.15 x Fan BHP.
2. Data includes pressure drop due to wet coils and filters.
3. No accessories or options are included in pressure drop data.
4. Refer to [Table 12, p. 29](#) to determine add'l static pressure drop due to other options/accessories.
5. Factory supplied motors, in commercial equipment, are definite purpose motors, specifically designed and tested to operate reliably and continuously at all cataloged conditions. Using the full horsepower range of our fan motors as shown in our tabulated data will not result in nuisance tripping or premature motor failure. Our product's warranty will not be affected.

Performance Data

Table 6. Evaporator fan performance 15 tons WS*180E downflow or horizontal

External Static Pressure (Inches of Water)																					
		0.10		0.20		0.30		0.40		0.50		0.60		0.70		0.80		0.90		1.00	
CFM	RPM	BHP	RPM	BHP	RPM	BHP	RPM	BHP	RPM	BHP	RPM	BHP	RPM	BHP	RPM	BHP	RPM	BHP	RPM	BHP	
3HP Standard Motor & Low Static Drive Accessory										3HP Standard Motor Drive											
4800	397	0.75	435	0.88	469	1.00	501	1.13	533	1.28	566	1.43	596	1.59	625	1.74	655	1.92	682	2.09	
5400	435	1.02	473	1.18	504	1.32	533	1.46	562	1.60	590	1.76	620	1.94	648	2.11	674	2.28	700	2.46	
6000	475	1.36	510	1.53	541	1.70	568	1.85	594	2.01	620	2.17	645	2.34	672	2.53	698	2.73	723	2.92 ^(a)	
6600	514	1.76	549	1.96	578	2.15	604	2.33	629	2.49	653	2.66	676	2.84	699	3.02	722	3.23	747	3.44	
7200	555	2.25	588	2.46	616	2.68	641	2.89	665	3.06	687	3.24 ^(b)	709	3.43	730	3.62	751	3.82	772	4.02	
										5HP Oversized Motor & Drive											

Continued

External Static Pressure (Inches of Water)																					
		1.10		1.20		1.30		1.40		1.50		1.60		1.70		1.80		1.90		2.00	
CFM	RPM	BHP	RPM	BHP	RPM	BHP	RPM	BHP	RPM	BHP	RPM	BHP	RPM	BHP	RPM	BHP	RPM	BHP	RPM	BHP	
3HP Standard Motor & High Static Drive Accessory										5HP Oversized Motor & Drive											
4800	708	2.27	734	2.46	758	2.66	782	2.86	806	3.06	829	3.25	850	3.45	872	3.65	893	3.85	913	4.04	
5400	727	2.65	752	2.85	776	3.05	799	3.25	821	3.47	843	3.69	865	3.91	886	4.13	907	4.36	927	4.58	
6000	747	3.11	770	3.30	794	3.51	817	3.73	839	3.95	861	4.17	881	4.40	902	4.63	922	4.87	942	5.12	
6600	770	3.66	793	3.87	815	4.08	835	4.28	857	4.51	879	4.74	900	4.98	—	—	—	—	—	—	
7200	794	4.25	817	4.49	839	4.73	860	4.96	—	—	—	—	—	—	—	—	—	—	—	—	

Notes:

1. Fan motor heat (MBH) = 3.15 x Fan BHP.
2. Data includes pressure drop due to wet coils and filters.
3. No accessories or options are included in pressure drop data.
4. Refer to [Table 12, p. 29](#) to determine add'l static pressure drop due to other options/accessories.
5. Factory supplied motors, in commercial equipment, are definite purpose motors, specifically designed and tested to operate reliably and continuously at all cataloged conditions. Using the full horsepower range of our fan motors as shown in our tabulated data will not result in nuisance tripping or premature motor failure. Our product's warranty will not be affected.

(a) 3HP Standard Motor & High Static Drive Accessory

(b) 5-hp Oversized Motor & Field Supplied Fan Sheave BK160 x 1 3/16 with BX75 (DF) or BX90 (HZ) Belt Required.



Performance Data

Table 7. Evaporator fan performance 20 tons WS*240E downflow or horizontal

External Static Pressure (Inches of Water)																					
		0.10		0.20		0.30		0.40		0.50		0.60		0.70		0.80		0.90		1.00	
CFM	RPM	BHP	RPM	BHP	RPM	BHP	RPM	BHP	RPM	BHP	RPM	BHP	RPM	BHP	RPM	BHP	RPM	BHP	RPM	BHP	
5HP Standard Motor Drive & low Static Drive Accessory											5HP Standard Motor Drive										
6400	—	—	—	—	507	1.72	535	1.88	560	2.07	584	2.27	607	2.46	631	2.66	654	2.86	677	3.07	
7200	—	—	519	2.10	549	2.30	576	2.48	600	2.67	623	2.88	644	3.10	665	3.32	686	3.54	707	3.76	
8000	531	2.50	563	2.77	592	3.00	617	3.21	641	3.41	663	3.62	684	3.86	704	4.10	723	4.34	742	4.58	
8800	578	3.26	607	3.56	634	3.83	659	4.08	683	4.31	704	4.54	724	4.77	744	5.01	762	5.27	779	5.54	
9600	626	4.19	653	4.51	679	4.81	703	5.10	725	5.36	746	5.62	765	5.85	784	6.11	802	6.36	819	6.64	
7.5HP Oversized Motor & Drive																					

Continued

External Static Pressure (Inches of Water)																					
		1.10		1.20		1.30		1.40		1.50		1.60		1.70		1.80		1.90		2.00	
CFM	RPM	BHP	RPM	BHP	RPM	BHP	RPM	BHP	RPM	BHP	RPM	BHP	RPM	BHP	RPM	BHP	RPM	BHP	RPM	BHP	
5HP Standard Motor Drive											7.5HP Oversized Motor & Drive										
6400	699	3.30	721	3.52	742	3.75	762	3.98	780	4.20	798	4.42	815	4.66	832	4.89	849	5.12	866	5.36	
7200	727	3.98	748	4.22	768	4.46	789	4.71	808	4.97	827	5.22	845	5.48	861	5.73	878	5.98	893	6.24	
8000	760	4.82	779	5.07	798	5.32	816	5.57	834	5.83	853	6.11	871	6.38	889	6.67	906	6.95	923	7.23 ^(a)	
8800	797	5.81	814	6.07	831	6.34	848	6.60	865	6.88	882	7.15	898	7.42	—	—	—	—	—	—	
9600	836	6.93	852	7.22	868	7.51	—	—	—	—	—	—	—	—	—	—	—	—	—	—	

Notes:

1. Fan motor heat (MBH) = 3.15 x Fan BHP.
2. Data includes pressure drop due to wet coils and filters.
3. No accessories or options are included in pressure drop data.
4. Refer to Table 12, p. 29 to determine add'l static pressure drop due to other options/accessories.
5. Factory supplied motors, in commercial equipment, are definite purpose motors, specifically designed and tested to operate reliably and continuously at all cataloged conditions. Using the full horsepower range of our fan motors as shown in our tabulated data will not result in nuisance tripping or premature motor failure. Our product's warranty will not be affected.
6. For multi-speed or single zone VAV applications, minimum "full" speed airflow must be set to 6800 cfm or higher to prevent VFD overheating during heating operation.

(a) 7.5-hp Oversized Motor & Field Supplied Motor Sheave 1VP50 x 1 1/8 Required.

Table 8. Standard motor & drive/fan speed (Rpm)

Tons	Unit Model No.	6 Turns Open	5 Turns Open	4 Turns Open	3 Turns Open	2 Turns Open	1Turn Open	Closed
12½	WS*150E3,4,W	500	537	574	611	648	685	N/A
15	WS*180E3,4,W	500	537	574	611	648	685	N/A
20	WS*240E3,4,W	605	650	695	739	784	829	N/A

Note: Factory set at 3 turns open.

Table 9. Standard motor & low static fan drive

Tons	Unit Model No.	6 Turns Open	5 Turns Open	4 Turns Open	3 Turns Open	2 Turns Open	1Turn Open	Closed
12½	WS*150E3,4,W	379	407	435	463	491	519	N/A
15	WS*180E3,4,W	379	407	435	463	491	519	N/A
20	WS*240E3,4,W	506	544	581	619	656	694	N/A

Table 10. Standard motor & high static drive accessory/fan speed (rpm)

Tons	Unit Model No.	6 Turns Open	5 Turns Open	4 Turns Open	3 Turns Open	2 Turns Open	1Turn Open	Closed
12½	WS*150E3,4,W	685	722	759	796	833	870	N/A
15	WS*180E3,4,W	685	722	759	796	833	870	N/A

Table 11. Oversized motor & drive/fan speed (rpm)

Tons	Unit Model No.	6 Turns Open	5 Turns Open	4 Turns Open	3 Turns Open	2 Turns Open	1Turn Open	Closed
12½	WS*150E3,4,W	695	747	798	850	901	953	N/A
15	WS*180E3,4,W	695	747	798	850	901	953	N/A
20	WS*240E3,4,W	694	739	784	829	874	919	N/A

Table 12. Static pressure drops through accessories (inches water column)

Tons	Unit Model No.	CFM	Standard Filters ^(a)	2"		Standard Economizer with OA/RA Dampers ^(c)		Low Leak Economizer with OA/RA Dampers ^(d)		Electric Heater Accessory (KW) ^(e)				
				MERV 8 Filters ^(b)	MERV 13 Filters ^(b)	100% OA	100% RA	100% OA	100% RA	14-				
										5-12	23	36	54	72
12½	WS*150E	4000	0.02	0.04	0.08	0.20	0.02	0.16	0.10	—	0.03	0.03	0.04	—
		5000	0.03	0.05	0.11	0.26	0.03	0.24	0.16	—	0.04	0.05	0.06	—
		6000	0.05	0.07	0.14	0.35	0.04	0.33	0.24	—	0.06	0.07	0.09	—
15	WS*180E	4800	0.03	0.05	0.10	0.24	0.03	0.22	0.15	—	0.04	0.04	0.05	—
		6000	0.05	0.07	0.14	0.35	0.04	0.33	0.24	—	0.06	0.07	0.08	—
		7200	0.07	0.09	0.17	0.42	0.05	0.45	0.35	—	0.09	0.10	0.12	—
20	WSH240E	6400	0.04	0.01	0.11	0.22	0.04	—	—	—	—	0.06	0.08	0.09
		8000	0.06	0.09	0.14	0.31	0.05	—	—	—	—	0.10	0.12	0.14
		9600	0.09	0.12	0.18	0.44	0.07	—	—	—	—	0.14	0.17	0.20
	WSD240E	6400	0.05	0.08	0.12	0.22	0.04	0.37	0.27	—	—	0.06	0.08	0.09
		8000	0.08	0.10	0.15	0.31	0.05	0.54	0.43	—	—	0.10	0.12	0.14
		9600	0.11	0.14	0.19	0.44	0.07	0.75	0.62	—	—	0.14	0.17	0.20

(a) Tested with: 2" filters 12 - 20 tons.
 (b) Difference in pressure drop should be considered when utilizing optional 2" pleated filters.
 (c) OA = Outside Air and RA = Return Air.
 (d) OA = Outside Air and RA = Return Air.
 (e) Nominal KW ratings at 240, 480, 600 volts.



Performance Data

Table 13. 12½ tons three phase heating capacities (net) WS*150E3, E4, EW at 5000 CFM

Outdoor Temp (°F) 70% RH	Integrated Heating Capacity (MBh/1000) at Indicated Dry Bulb Temp (°F)				Total Power in Kilowatts at Indicated Dry Bulb Temp (°F)			
	60	70	75	80	60	70	75	80
-8	50.9	48.5	47.2	45.9	9.6	10.3	10.8	11.3
-3	56.9	54.5	53.4	52.1	9.7	10.4	10.9	11.4
2	63.3	60.6	59.3	58.0	9.7	10.5	10.9	11.4
7	69.7	66.6	65.5	64.0	9.8	10.6	11.0	11.5
12	76.1	72.5	71.7	70.2	9.9	10.7	11.1	11.6
17	82.0	79.0	77.3	76.9	10.0	10.8	11.3	11.8
22	89.7	86.5	84.8	83.5	10.1	10.9	11.3	11.9
27	96.8	93.5	91.8	90.2	10.1	11.0	11.5	12.0
32	104.6	100.8	99.1	97.2	10.2	11.1	11.6	12.1
37	112.0	108.1	106.1	104.3	10.3	11.2	11.7	12.2
42	129.1	124.4	122.2	120.0	10.5	11.4	11.9	12.5
47	148.4	142.8	140.1	137.4	10.7	11.6	12.1	12.7
52	156.7	151.0	148.0	145.2	10.8	11.7	12.2	12.8
57	166.0	159.8	156.8	153.6	10.9	11.9	12.4	12.9
62	175.5	168.6	165.3	162.0	11.0	12.0	12.5	13.1
67	185.2	177.6	174.5	170.0	11.2	12.1	12.7	13.2
72	193.6	185.7	181.6	177.6	11.3	12.3	12.8	13.4

Notes:

1. For other airflow conditions, see heating capacity correction factor Net Heating Capacity and Power Input include indoor fan heat at nominal CFM and 0.35 inch ESP. To obtain net heating at other conditions, subtract fan heat at this condition and add fan heat at new condition.
2. Heating capacities and powers are integrated to include the effects of defrost in the frost region.
3. All heating capacities and power (kW) are at 70% OD relative humidity.

Table 14. 15 tons three phase heating capacities (net) WS*180E3, E4, EW at 6000 CFM

Outdoor Temp (°F) 70% RH	Integrated Heating Capacity (MBh/1000) at Indicated Dry Bulb Temp (°F)				Total Power in Kilowatts at Indicated Dry Bulb Temp (°F)			
	60	70	75	80	60	70	75	80
-8	56.3	54.8	54.0	53.2	10.5	11.5	12.0	12.5
-3	62.8	61.1	60.2	59.4	10.7	11.7	12.1	12.7
2	69.5	67.6	66.7	65.7	10.9	11.8	12.4	12.9
7	76.2	71.1	69.9	70.8	11.1	12.0	12.5	14.0
12	82.9	73.0	76.9	77.0	12.0	12.1	12.7	13.7
17	88.2	85.4	84.0	82.7	11.4	12.4	12.9	13.5
22	95.9	92.8	91.4	89.9	11.6	12.5	13.1	13.7
27	103.8	100.6	98.9	97.3	11.8	12.7	13.3	13.9
32	112.3	109.0	107.1	105.5	11.9	13.0	13.5	14.1
37	120.8	117.1	115.4	113.7	12.1	13.2	13.8	14.4
42	148.0	143.6	141.4	139.1	12.2	13.3	13.9	14.5
47	179.2	173.8	170.8	168.0	12.6	13.6	14.2	14.8
52	190.8	185.3	182.3	179.0	12.8	13.9	14.4	15.0
57	204.1	197.7	194.2	191.5	13.1	14.1	14.7	15.3
62	217.8	210.6	207.5	203.7	13.4	14.4	15.0	15.6
67	233.5	225.5	221.1	217.0	13.7	14.8	15.4	16.0
72	247.8	239.7	235.5	231.2	14.1	15.2	15.8	16.4

Notes:

1. For other airflow conditions, see heating capacity correction factor Net Heating Capacity and Power Input include indoor fan heat at nominal CFM and 0.35 inch ESP. To obtain net heating at other conditions, subtract fan heat at this condition and add fan heat at new condition.
2. Heating capacities and powers are integrated to include the effects of defrost in the frost region.
3. All heating capacities and power (kW) are at 70% OD relative humidity.



Performance Data

Table 15. 20 tons three phase heating capacities (Net) WS*240E3, E4, EW at 8000 CFM

Outdoor Temp (°F) 70% RH	Integrated Heating Capacity (MBh/1000) at Indicated Dry Bulb Temp (°F)				Total Power in Kilowatts at Indicated Dry Bulb Temp (°F)			
	60	70	75	80	60	70	75	80
-8	80.6	78.4	77.6	76.8	15.1	15.9	16.4	16.9
-3	87.5	85.3	84.5	83.4	15.3	16.0	16.5	17.0
2	96.3	93.9	92.8	91.7	15.4	16.2	16.7	17.2
7	106.0	103.2	102.3	101.0	15.5	16.3	16.8	17.3
12	118.3	116.2	115.5	114.7	15.7	16.5	17.0	17.5
17	131.1	128.2	127.4	126.3	15.9	16.7	17.2	17.7
22	142.9	140.3	138.8	137.2	16.1	16.9	17.4	17.9
27	154.1	151.3	150.0	148.6	16.4	17.3	17.8	18.3
32	165.5	162.4	161.2	159.6	16.5	17.4	17.9	18.4
37	180.9	177.6	175.7	174.5	16.8	17.7	18.2	18.7
42	196.5	191.9	189.8	188.2	17.0	17.9	18.4	18.9
47	213.3	209.1	207.0	205.4	17.1	18.0	18.5	19.0
52	228.9	224.2	221.4	219.8	17.4	18.3	18.8	19.3
57	243.4	237.7	235.6	233.0	17.8	18.8	19.3	19.8
62	261.9	255.7	252.6	250.0	20.0	21.1	21.6	22.1
67	279.6	272.0	268.9	265.3	20.1	21.2	21.7	22.2
72	298.5	291.1	287.9	283.8	20.4	21.5	22.0	22.6

Notes:

1. For other airflow conditions, see heating capacity correction factor Net Heating Capacity and Power Input include indoor fan heat at nominal CFM and 0.35 inch ESP. To obtain net heating at other conditions, subtract fan heat at this condition and add fan heat at new condition.
2. Heating capacities and powers are integrated to include the effects of defrost in the frost region.
3. All heating capacities and power (kW) are at 70% OD relative humidity.

Table 16. Heating capacity correction factors

% Variation of Nominal CFM	- 20	- 10	0	+ 10	+ 20
Total Gross Capacity Multiplier	0.96	0.98	1.0	1.01	1.02

Table 17. Auxiliary electric heat capacity

Tons	Unit Model No.	Total ^(a)		No. of Stages	Stage 1		Stage 2	
		KW	MBh		KW	MBh	KW	MBh
		Input ^(b)	Output		Input ^(b)	Output	Input ^(b)	Output
12½, 15	WS*150E3, E4, EW WS*180E3, E4, EW	18.00	61.00	1	18.00	61.00	-	-
		36.00	123.00	2	18.00	61.00	18.00	61.00
		54.00	184.00	2	36.00	123.00	18.00	61.00
20	WS* 240E3, E4, EW	36.00	123.00	2	18.00	61.00	18.00	61.00
		54.00	184.00	2	36.00	123.00	18.00	61.00
		72.00	246.00	2	36.00	123.00	36.00	123.00

(a) Heaters are rated at 240v,380v,480v and 600v. For other than rated voltage, CAP= (voltage/rated voltage)2 x rated cap.
 (b) For all input/output categories, does not include fan power or heat.

Table 18. Electric heater voltage correction factors (applicable to auxiliary heat capacity)

Nominal Voltage	Distribution Voltage	Capacity Multiplier
240	208	0.75
	230	0.92
	240	1.00
480	440	0.84
	460	0.94
	480	1.00
600	540	0.81
	575	0.92
	600	1.00

Table 19. Air temperature rise across electric heaters (°F)

KW	Stages	12½ Ton 5000 CFM	15 Ton 6000 CFM	20 Ton 8000 CFM
		Three Phase WS*150E	Three Phase WS*180E	Three Phase WS*240E
9.00	1	-	-	-
17.30	1	-	-	-
18.00	1	11.4	9.5	-
27.00	2	-	-	-
36.00	2	23.0	19.0	14.2
54.00	2	34.1	28.4	21.3
72.00	2	-	-	28.5

Table 20. Electric heater temperature rise correction factors

% Variation From Nominal CFM	- 20	- 15	- 10	- 5	0	+5	+10	+15	+20
Temperature Rise Multiplier	1.25	1.17	1.11	1.05	1.00	0.95	0.91	0.87	0.83

Controls

Field Installed Control Options

Zone Sensors

Note: Zone sensor required for units configured for Single Zone VAV indoor fan system control to enable Single Zone VAV functionality.

Zone Sensors are the building occupant's comfort control devices for Voyager™ units with ReliaTel:

Manual Changeover

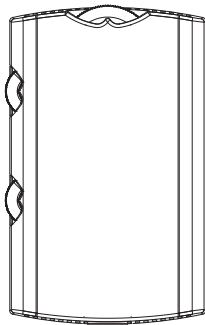

Heat, Cool or Off System Switch. Fan Auto or Off Switch. One temperature setpoint lever

Manual/Automatic Changeover

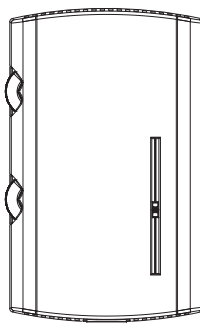

Auto, Heat, Cool or Off System Switch. Fan Auto or Off Switch. Two temperature setpoint levers

Manual/Automatic Changeover

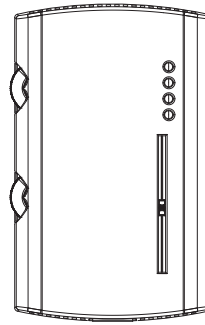

Auto, Heat, Cool or Off System Switch. Fan Auto or Off Switch. Two temperature setpoint levers. Status Indication LED lights, System On, Heat, Cool, or Service.

Manual/Automatic Changeover

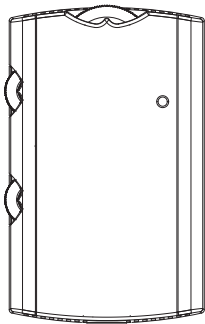

Auto, Heat, Cool or Off System Switch. Fan Auto or Off Switch. Two temperature setpoint levers

Remote Sensor

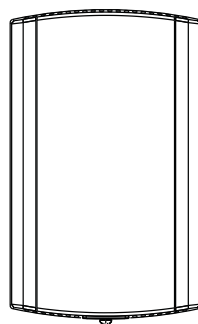

Sensor(s) available for all zone sensors to provide remote sensing capabilities

Integrated Comfort™ System

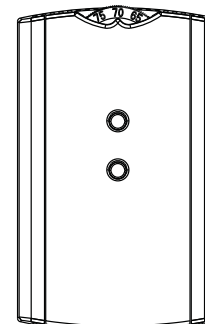

Sensor(s) available with optional temperature adjustment and override buttons to provide central control through a Trane Integrated Comfort™ system.

RA Remote Sensor

Return Air Remote Sensor which can be mounted in the return air duct to report return air temperature.

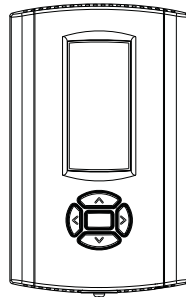
Programmable Night Setback

Auto or manual changeover with seven-day programming. Keyboard selection of Heat, Cool, Fan, Auto, or On. All programmable sensors have System On, Heat, Cool, Service LED/indicators as standard. Night Setback Sensors have one (1) Occupied, one (1) Unoccupied, and one (1) Override program per day.

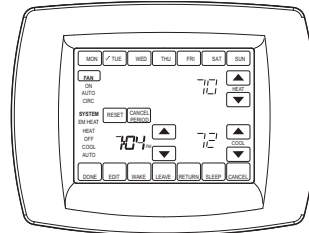
Touchscreen Programmable Thermostat (2H/2C)

Two Heat/Two Cool programmable thermostat with touch screen digital display. Menu-driven programming. Effortless set-up. Program each day separately with no need to copy multiple days. All programming can be done on one screen. Easy to read and use. Large, clear backlit digital display.

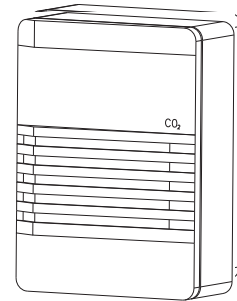
CO₂ Sensor

The CO₂ sensor shall have the ability to monitor the concentration (parts per million, ppm) of CO₂ (Carbon Dioxide) in the air. As the CO₂ concentration changes, the outside air damper modulates to meet the current ventilation needs of the zone.

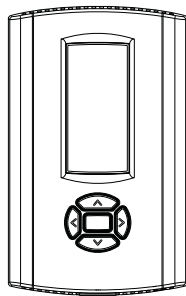
Digital Display Programmable Thermostat (3H/2C)

Two Heat/Two Cool auto changeover digital display thermostat. 7-day programmable stat with night setback shall be available

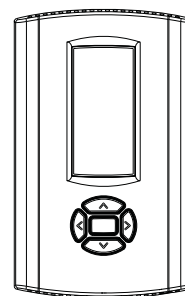
Digital Display Thermostat (3H/2C)

Three Heat, Two Cool auto changeover digital display thermostat.

Dual Thermistor Remote Zone Sensor

This sensor will allow the customer to reduce the total number of remote sensors to obtain space temperature averaging. This sensor should be utilized with ReliaTel controls.

Room Remote Sensor

Space Remote Sensor which can be mounted on the wall to report/control from a remote location in the space.



Electrical Data

Table 21. Unit wiring

Tons	Unit Model #	Unit Operating Voltage Range	Standard Indoor Motor		Oversize Indoor Fan Motor	
			Minimum Circuit Ampacity	Max Fuse Size or Max Circuit Breaker ^(a)	Minimum Circuit Ampacity	Max Fuse Size or Max Circuit Breaker ^(a)
12½	WS*150E3	187-253	68	80	74	90
	WS*150E4	414-506	32	40	35	45
	WS*150EW	517-633	25	30	27	30
15	WS*180E3	187-253	74	90	80	100
	WS*180E4	414-506	36	45	39	50
	WS*180EW	517-633	30	35	32	40
20	WS*240E3	187-253	116	150	124	150
	WS*240E4	414-506	56	70	59	70
	WS*240EW	517-633	45	60	48	60

(a) HACR type circuit breaker per NEC.

Table 22. Unit wiring with electric heat (single point connection) – standard refrigeration system (downflow and horizontal)

Tons	Unit Model Number	Heater Model Number ^(a)	Heater kW Rating	Control Stages	Standard Indoor Motor		Oversize Indoor Motor	
					MCA	Max Fuse Size or Max Circuit Breaker	MCA	Max Fuse Size or Max Circuit Breaker ^(b)
208/230 Volts Three Phase								
12½	WS*150E3	AYDHTRK318/AYHHTRM318	13.5/18.0	1	115/123	125/125	121/129	125/150
		AYDHTRK336/AYHHTRM336	27.0/36.0	2	168/183	175/200	174/189	175/200
		AYDHTRK354/AYHHTRM354	40.5/54.0	2	209/198	225/200	215/204	225/225
15	WS*180E3	AYDHTRK318/AYHHTRM318	13.5/18.0	1	121/129	125/150	127/135	150/150
		AYDHTRK336/AYHHTRM336	27.0/36.0	2	168/183	175/200	174/189	175/200
		AYDHTRK354/AYHHTRM354	40.5/54.0	2	215/204	225/225	221/210	225/225
20	WS*240E3	AYDHTRK336/AYHHTRN336	27.0/36.0	2	210/225	225/225	218/233	225/250
		AYDHTRK354/AYHHTRN354	40.5/54.0	2	257/246	300/250	265/254	300/300
		AYDHTRK372/AYHHTRN372	54.0/72.0	2	267/290	300/300	275/298	300/300
460 Volts Three Phase								
12½	WS*150E4	AYDHTRK418/AYHHTRM418	18	1	60	60	63	70
		AYDHTRK436/AYHHTRP436	36	2	87	90	90	90
		AYDHTRK454/AYHHTRM454	54	2	97	100	100	100
15	WS*180E4	AYDHTRK418/AYHHTRM418	18	1	64	70	67	70
		AYDHTRK436/AYHHTRM436	36	2	91	100	94	100
		AYDHTRK454/AYHHTRM454	54	2	101	110	104	110
20	WS*240E4	AYDHTRK436/AYHHTRN436	36	2	111	125	114	125
		AYDHTRK454/AYHHTRN454	54	2	121	125	125	125
		AYDHTRK472/AYHHTRN472	72	2	143	150	146	150

Table 22. Unit wiring with electric heat (single point connection) – standard refrigeration system (downflow and horizontal) (continued)

Tons	Unit Model Number	Heater Model Number ^(a)	Heater kW Rating	Control Stages	Standard Indoor Motor		Oversize Indoor Motor	
					MCA	Max Fuse Size or Max Circuit Breaker	MCA	Max Fuse Size or Max Circuit Breaker ^(b)
575 Volts Three Phase								
12½	WS*150EW	AYDHTRKW18 (AYDHTRLW18) ^(a) /AYHHTRMW18 (AYHHTRPW18)	18	1	47	50	49	50
		AYDHTRKW36/AYHHTRMW36 (AYHHTRRW36) ^(a)	36	2	69	70	71	80
		AYDHTRKW54/AYHHTRMW54	54	2	77	80	79	80
15	WS*180EW	AYDHTRKW18 (AYDHTRMW18) ^(a) /AYHHTRMW18 (AYHHTRQW18)	18	1	52	60	54	60
		AYDHTRKW36/AYHHTRMW36 (AYHHTRSW36) ^(a)	36	2	74	80	76	80
		AYDHTRKW54/AYHHTRMW54	54	2	82	90	84	90
20	WS*240EW	AYDHTRLW36/AYHHTRNW36	36	2	89	90	92	100
		AYDHTRLW54/AYHHTRNW54	54	2	97	110	100	110
		AYDHTRKW72/AYHHTRNW72	72	2	115	125	118	125

(a) Heater model numbers in parenthesis apply to units with an optional high SCCR rating.

(b) Values do not include power exhaust accessory.

* Indicates both downflow and horizontal units.

Table 23. Electrical characteristics - power exhaust accessory

Tons	Accessory Operating Voltage	Phase	HP	RPM	Amps FLA	LRA
12½, 15, 20	208-230	1	3/4	1040	6.6	13.5
	460	1	3/4	1040	3.2	8.4
	575	1	3/4	1040	2.1	5.2

Table 24. Electrical characteristics - evaporator fan motors - 60 cycle

Tons	Unit Model No.	Standard Evaporator Fan Motor						Oversized Evaporator Fan Motor					
		No.	Volts	Phase	HP	Amps		No.	Volts	Phase	HP	Amps	
						FLA	LRA					FLA	LRA
12½	WS*150E3	1	208-230	3	3.00	10.6	81.0	1	208-230	3	5.00	16.7	109.8
	WS*150E4	1	460	3	3.00	4.8	40.5	1	460	3	5.00	7.6	54.9
	WS*150EW	1	575	3	3.00	3.9	31.0	1	575	3	5.00	6.1	41.6
15	WS*180E3	1	208-230	3	3.00	10.6	81.0	1	208-230	3	5.00	16.7	109.8
	WS*180E4	1	460	3	3.00	4.8	40.5	1	460	3	5.00	7.6	54.9
	WS*180EW	1	575	3	3.00	3.9	31.0	1	575	3	5.00	6.1	41.6
20	WS*240E3	1	208-230	3	5.00	16.7	109.8	1	208-230	3	7.50	24.2	120.4
	WS*240E4	1	460	3	5.00	7.6	54.9	1	460	3	7.50	11.0	74.0
	WS*240EW	1	575	3	5.00	6.1	41.6	1	575	3	7.50	9.0	60.0



Electrical Data

Table 25. Electrical characteristics — compressor motor and condenser motor — 60 cycle

Tons	Unit Model Number	No.	Compressor Motors						Condenser Fan Motors				
			Volts	Phase	HP ^(b)	RPM	Amps ^(a)		No.	Phase	HP	Amps	
							RLA	LRA				FLA	LRA
12½	WS*150E3	2	208-230	3	5.6	3450	22.4	149	2	1	0.5	3.2	8.8
	WS*150E4	2	460	3	5.6	3450	10.6	75	2	1	0.5	1.6	3.8
	WS*150EW	2	575	3	5.6	3450	7.9/7.7	54	2	1	0.5	1.3	3.2
15	WS*180E3	2	208-230	3	6.9	3450	25	164	2	1	0.5	3.2	8.8
	WS*180E4	2	460	3	6.9	3450	12.5/12.2	100	2	1	0.5	1.6	3.8
	WS*180EW	2	575	3	6.9	3450	10.3/10.1	78	2	1	0.5	1.3	3.2
20	WS*240E3	2	208-230	3	10.4	3450	39.1	267	2	1	1	5.0	14.4
	WS*240E4	2	460	3	10.4	3450	17.3	142	2	1	1	2.5	5.8
	WS*240EW	2	575	3	10.4	3450	15.4	103	2	1	1	2	5.1

(a) For Compressor Motors and Condenser Fan Motors: Amp draw for each motor; multiply value by number of motors to determine total amps.

(b) HP for each compressor.

*Indicates both downflow and horizontal units.

Dimensional Data

Figure 2. Heat pump models - 12½ - 20 tons

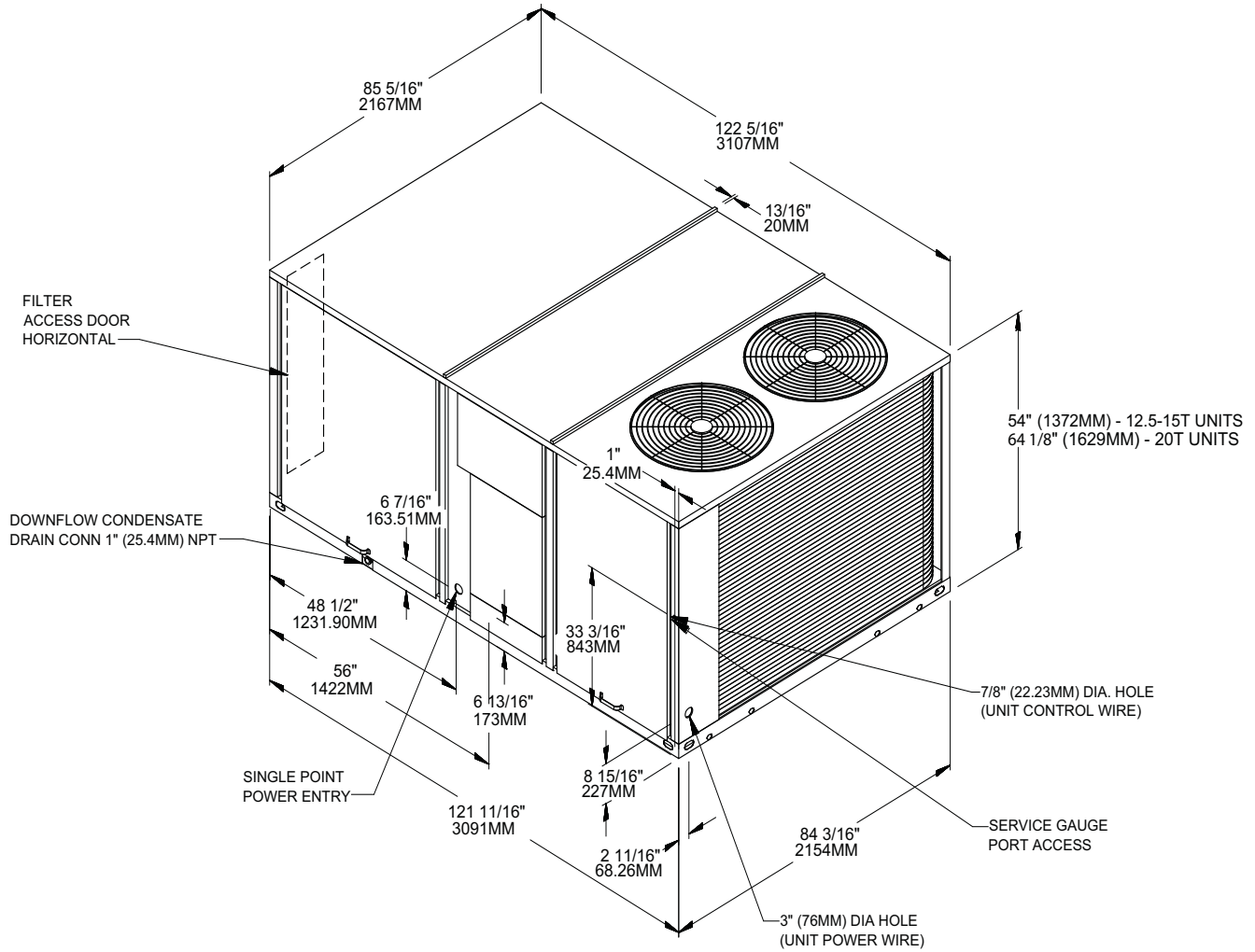

* All dimensions are in inches/millimeters.

Dimensional Data

Figure 3. Heat pump models - 12½ - 20 tons

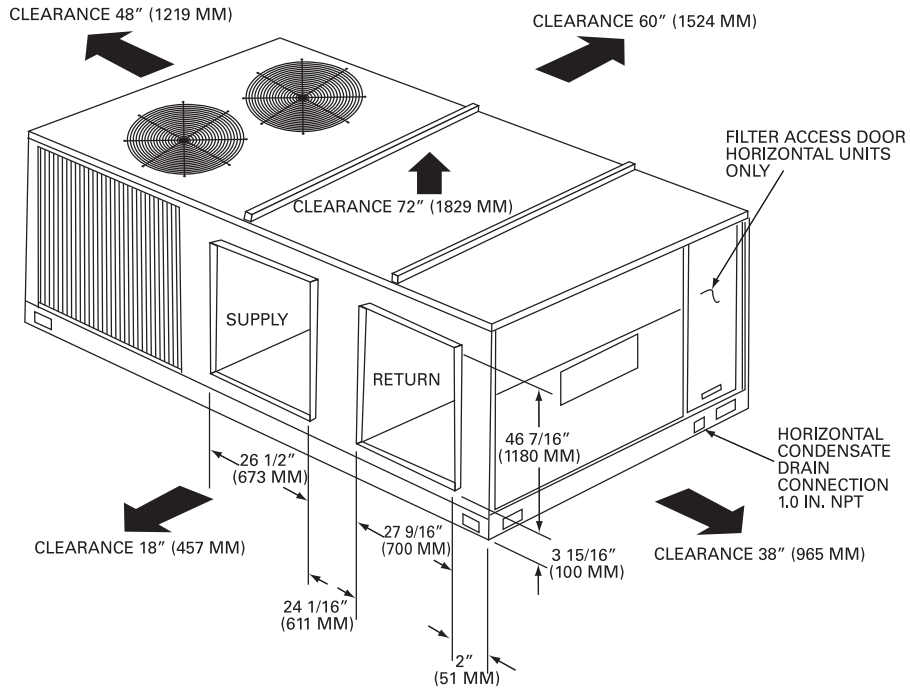

* All dimensions are in inches/millimeters.

Figure 4. Heat pump models - 12½ - 20 tons

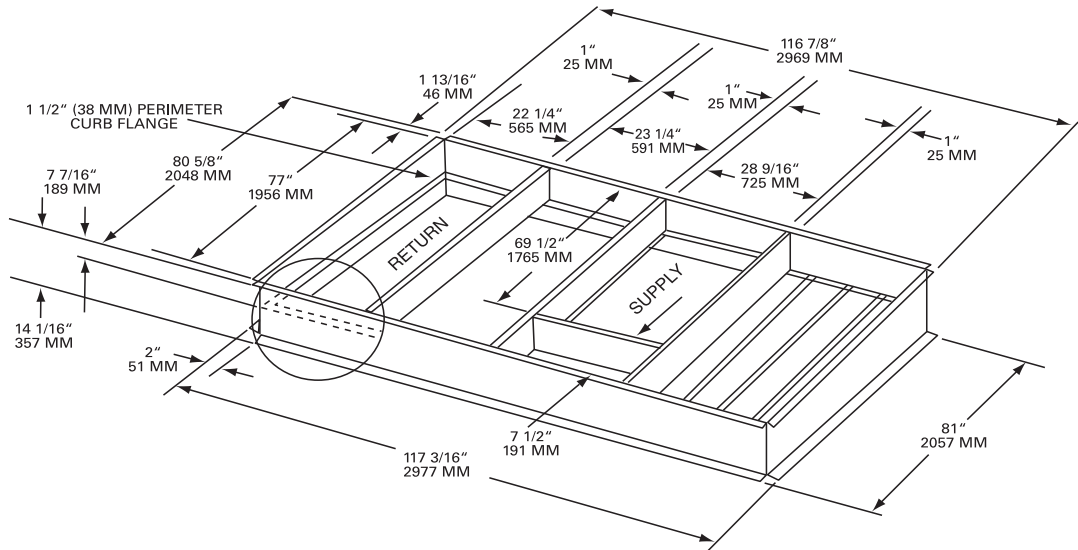

* All dimensions are in inches/millimeters.

Figure 5. Heat pump models - 12½ - 20 tons

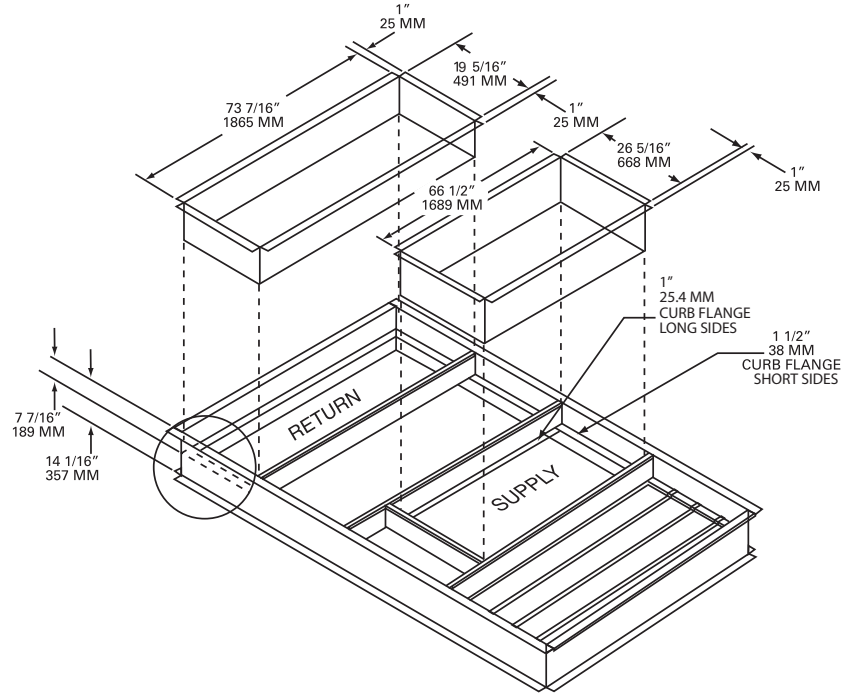

* Duct flanges mount 7-7/16" down inside the curb on the 1-1½ curb flanges.
 Roofcurb is intended for downflow use only.
 * All dimensions are in inches/millimeters.

Figure 6. Heat pump models - 12½ - 20 tons

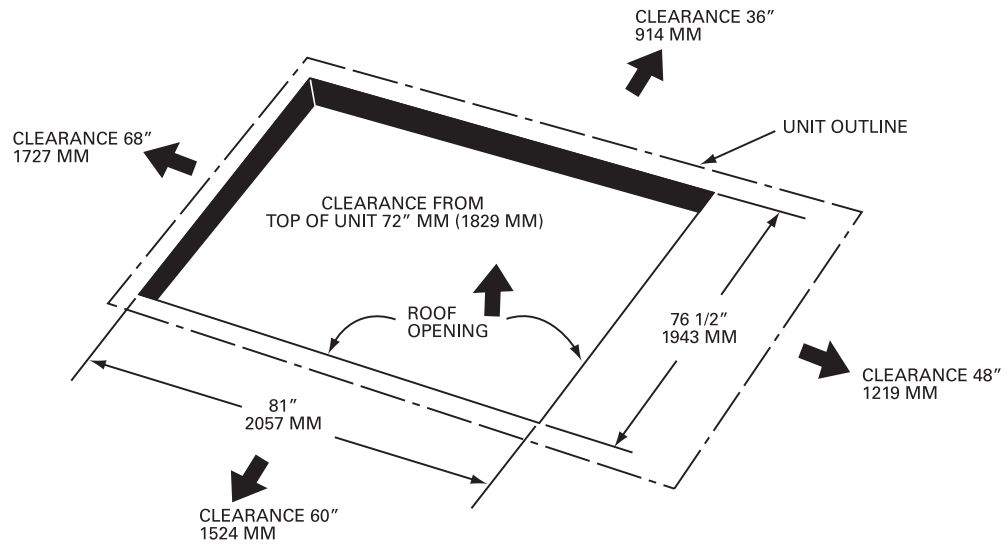

* All dimensions are in inches/millimeters.

Dimensional Data

Figure 7. Downflow & horizontal condensate locations

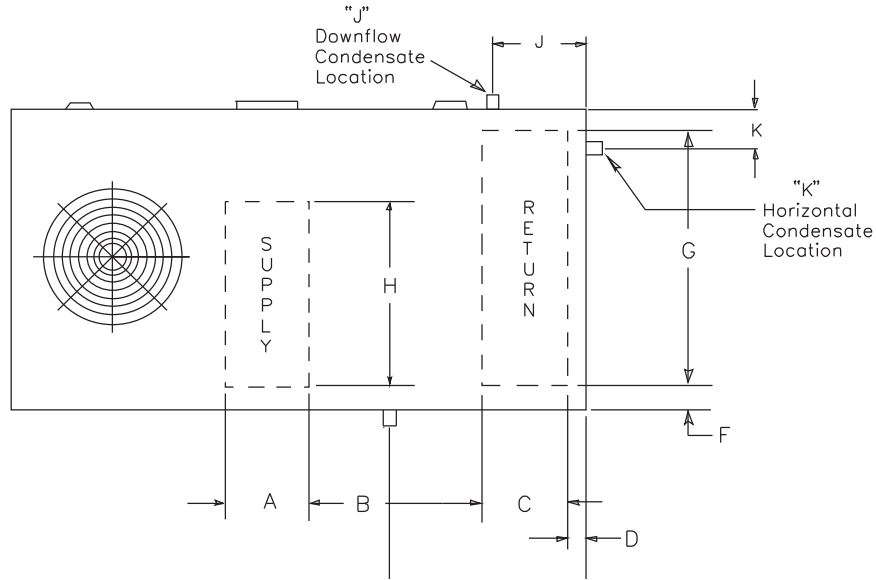

Table 26. Heat pump units

Tons	Downflow Only							Condensate Drain Size	Condensate Drain Location	
	A	B	C	D	F	G	H		Downflow	Horizontal
									J	K
12½, 15, 20	26 7/16	28 3/4	19 15/16	4 1/4	4 1/4	76 5/16	68 11/16	1 NPT	26 3/4	5 3/8

Table 27. Swing clearances

Unit Model #	A	B	C	D	E
WSD 150-240	29 1/2	56	38 1/2	18 1/2	N/A
WSH 150-240	29 1/2	N/A	38 1/2	18 1/2	14

Note: All dimensions are in inches.

TOP VIEW SHOWING THROUGH THE BASE
ELECTRICAL UTILITY LOCATIONS AND ACCESS PANEL SWING CLEARANCES.

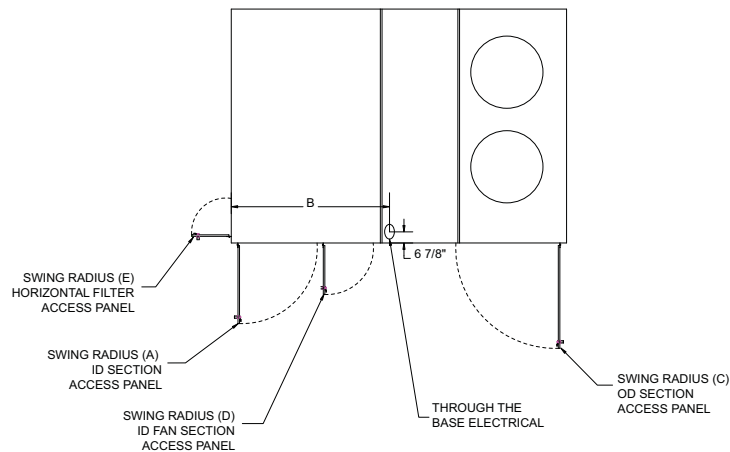

Figure 8. Fresh air hood (horizontal units)

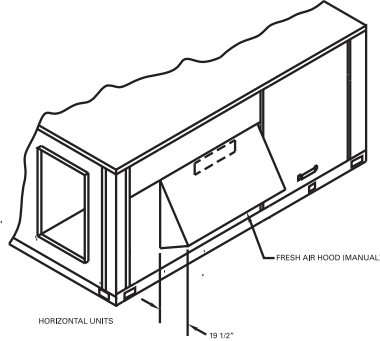

Figure 9. Fresh air hood (downflow units)

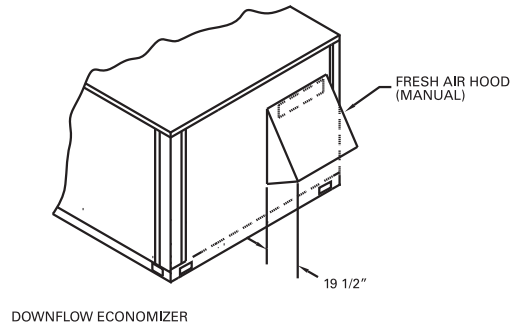

Figure 10. Power exhaust - downflow economizers

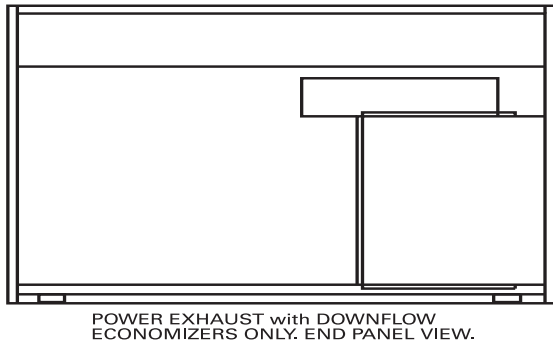

Figure 11. Power exhaust - downflow economizers - side view

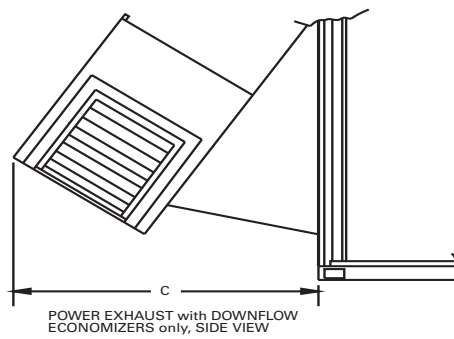

Figure 12. Economizer - horizontal units

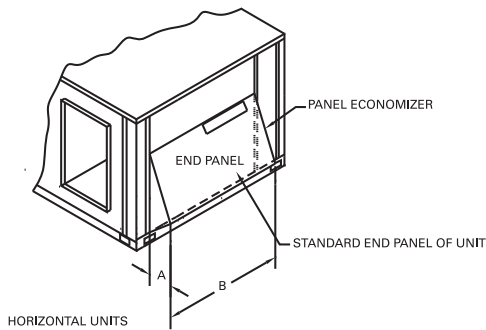
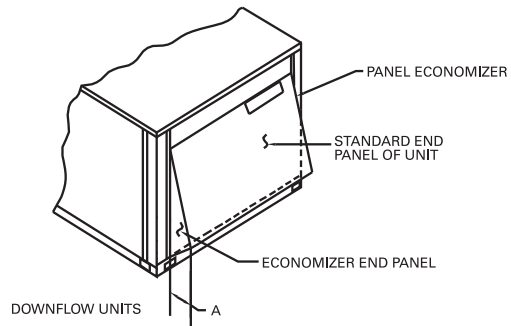

Figure 13. Economizer - downflow units



Note: When applying economizer to horizontal units, connected ductwork must be run full size to allow proper operation of economizer damper.

Table 28. Power exhaust dimensions

Unit Model #	A	B(a)	C(b)
WS* 150-240	19½	64¾	39

(a) Horizontal dimension only. Downflow economizer is width of end panel.

(b) Power exhaust is applied on downflow economizer only.

Weights

Table 29. Accessory net weights (lbs)

Tons	Unit Model No.	Std Economizer (a)		Low Leak Economizer	Outside Air Damper		Power Exhaust (b)	Roof Curb	Oversized Motor Adder	High Static Drive
		Net	Ship	Net	Manual	Moto-rized				
12½, 15, 20	WSD150-240E	80	265	250	32	75	95	235	5	10
12½, 15, 20	WSH150-240E	65	210	-	32	75	-	-	5	15

(a) Net weight should be added to unit weight when ordering factory installed economizer or oversize motor.
 (b) Downflow only.

Table 30. Electric heaters weights

Tons	Unit Model No.	All Zone Sensors	Electric Heaters(a)(b)			
			5-18 kW 240/480V	23-36 kW 240/480V	54 kW 240/480V	72 kW 240/480V
12½-20	WS*150E, 180E, 240E	1	28/22	33/27	40/32	43/34

(a) For 600V heaters net weights are same as 480V heaters.
 (b) To estimate shipping weight add 5 lbs to net weight.

Table 31. Variable frequency drive weights

Motor Size	WSD150-240E	WSH150-240E
3(a) & 5 HP	32	34
7.5 HP(b)	63	65

(a) 3 HP motors not applicable to WS*240E units.
 (b) WS*240E units only.

Figure 14. Center of gravity

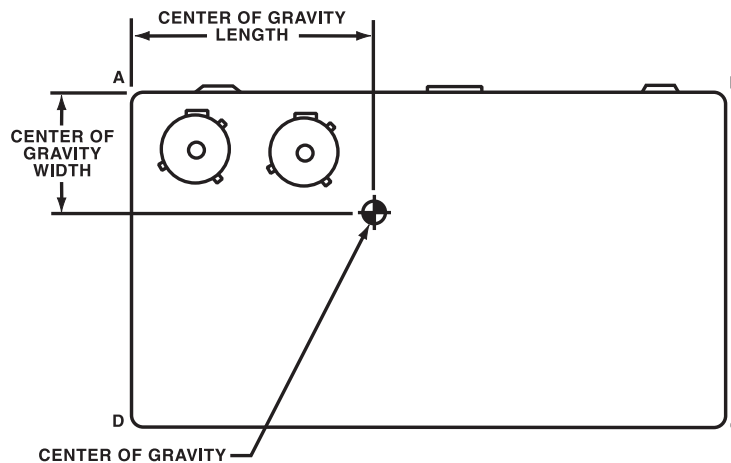

Table 32. Maximum unit & corner weights (lbs) and center of gravity dimensions (In.)

Tons	Unit Model No.	Maximum Weights (Lbs)		Corner Weights (Lbs)				Center of Gravity (In.)	
		Shipping	Net	A	B	C	D	Length	Width
12½	WS*150E	2430	1978	633	514	376	455	56	36
15	WS*180E	2435	1982	634	515	377	456	56	36
20	WS*240E	2566	2107	674	485	400	590	57	35

Table 33. Factory installed options (FIOPS) net weights (lbs)(a)(b)(c)

Accessory	Weight	Unit Model No.
High Efficiency Motors ^(d)	49	WS*150-180 standard size motor
	36	WS*240 standard size motor
		WS*150-180 oversized motor
	0	WS*240 oversized size motor
Hinged Doors	27	All WS* units
Powered Convenience Outlet	38	All WS* units
Through the Base Electrical	23	All WS* units
Unit Mounted Circuit Breaker	5	All WS* units except those with 54&72 kW heaters & 208/230V
	10	All WS* units with 54&72 kW heaters & 208/230V
Unit Mounted Disconnect	5	All WS* units except those with 54&72 kW heaters & 208/230V
	10	All WS* units with 54&72 kW heaters & 208/230V
Smoke Detectors (Supply/Return)	5	All WS* units
Tool-less Hail Guard	43	WS*150,180
	51	WS*240
Stainless Steel Drain Pan	8.1	All WS* units

(a) Weights for FIOP accessories not listed are < 5 lbs.

(b) Net weight should be added to unit weight when ordering factory installed accessories.

(c) See [Table 29, p. 44](#) for standard factory installed economizer and oversized motors.

(d) Standard factory installed motors are already included in unit net and shipping weights. Values shown for high efficiency motors are in addition to the standard motor weight.

* Indicates both downflow and horizontal units.

Typical Wiring

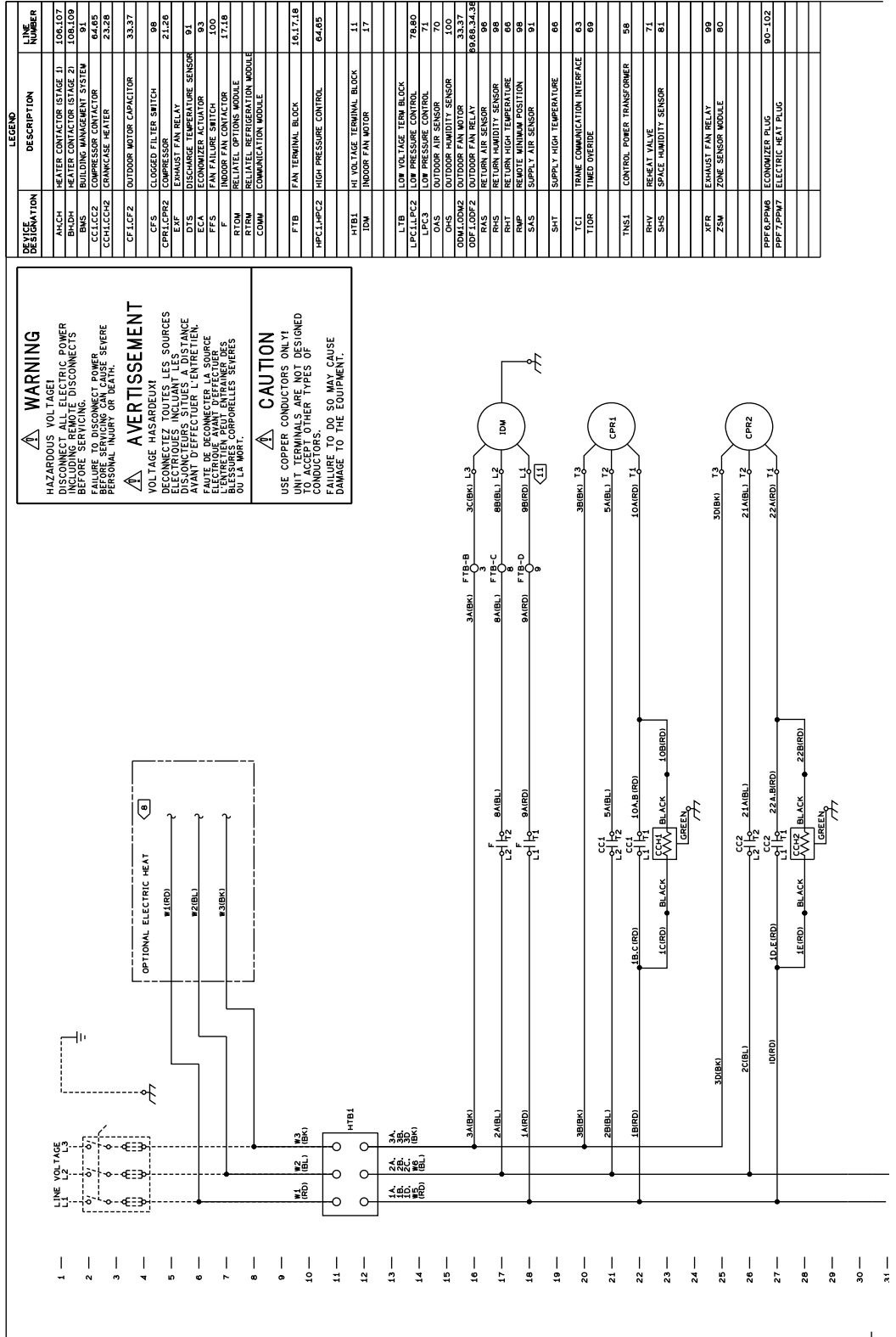

- NOTES:**
- UNLESS OTHERWISE NOTED, ALL SWITCHES ARE SHOWN AT 25°C (77°F), AT ATMOSPHERIC PRESSURE. IF TURNED OFF, AND AFTER A NORMAL SHUTDOWN HAS OCCURRED, ALL THERMISTORS ARE ON AT 25°C (77°F).
 - DASHED LINES INDICATE RECOMMENDED FIELD WIRING. DEVICES AND LINES INDICATE COMPONENTS PROVIDED BY ALTERNATE CIRCULARITY OR AVAILABLE SALES OPTIONS.
 - NUMBERS ALONG THE RIGHT SIDE OF THE SCHEMATIC INDICATE THE WIRE NUMBER. A DASHED LINE NUMBER ALONG THE WIRE INDICATES A NORMALLY CLOSED CONTACT.
 - THREE PHASE MOTORS ARE PROTECTED UNDER PRIMARY INTERNAL OVERLOAD PROTECTION. COMPRESSORS HAVE INTERNAL THERMAL PROTECTION.

- 7 CONNECTIONS SHOWN ARE FOR 480V/60HZ/3PH OR 380V-415V/ 3PH SYSTEMS. IF A 208V/60HZ/3PH SYSTEM IS REQUIRED, REMOVE WIRE #208B1 FROM 480V/400V TERMINAL ON TNS1 AND CONNECT TO 575V TERMINAL ON TNS1.
- 8 SEE APPLICABLE HEATING SECTION DIAGRAM FOR BALANCE OF CIRCUIT WHEN OPTIONAL ELECTRIC HEAT IS REQUIRED.

11 TERMINALS MAY NOT BE PRESENT.

WIRE	COLOR	DESIGNATION	COLOR
480B1	GR	480B1	GR
480B2	BL	480B2	BL
480B3	BL	480B3	BL
480B4	BL	480B4	BL
480B5	BR	480B5	BR
480B6	GR	480B6	GR
480B7	OR	480B7	OR

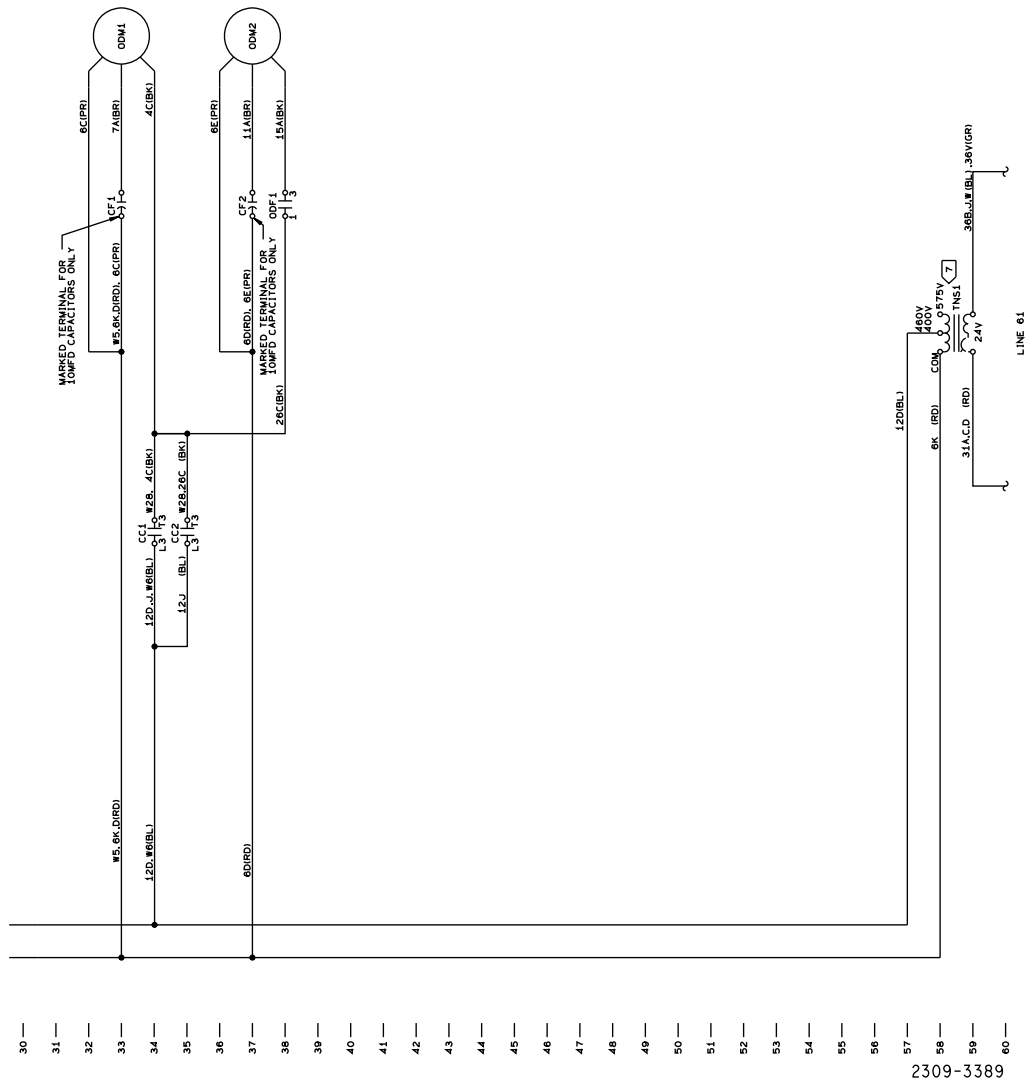

2309-3389

Typical Wiring

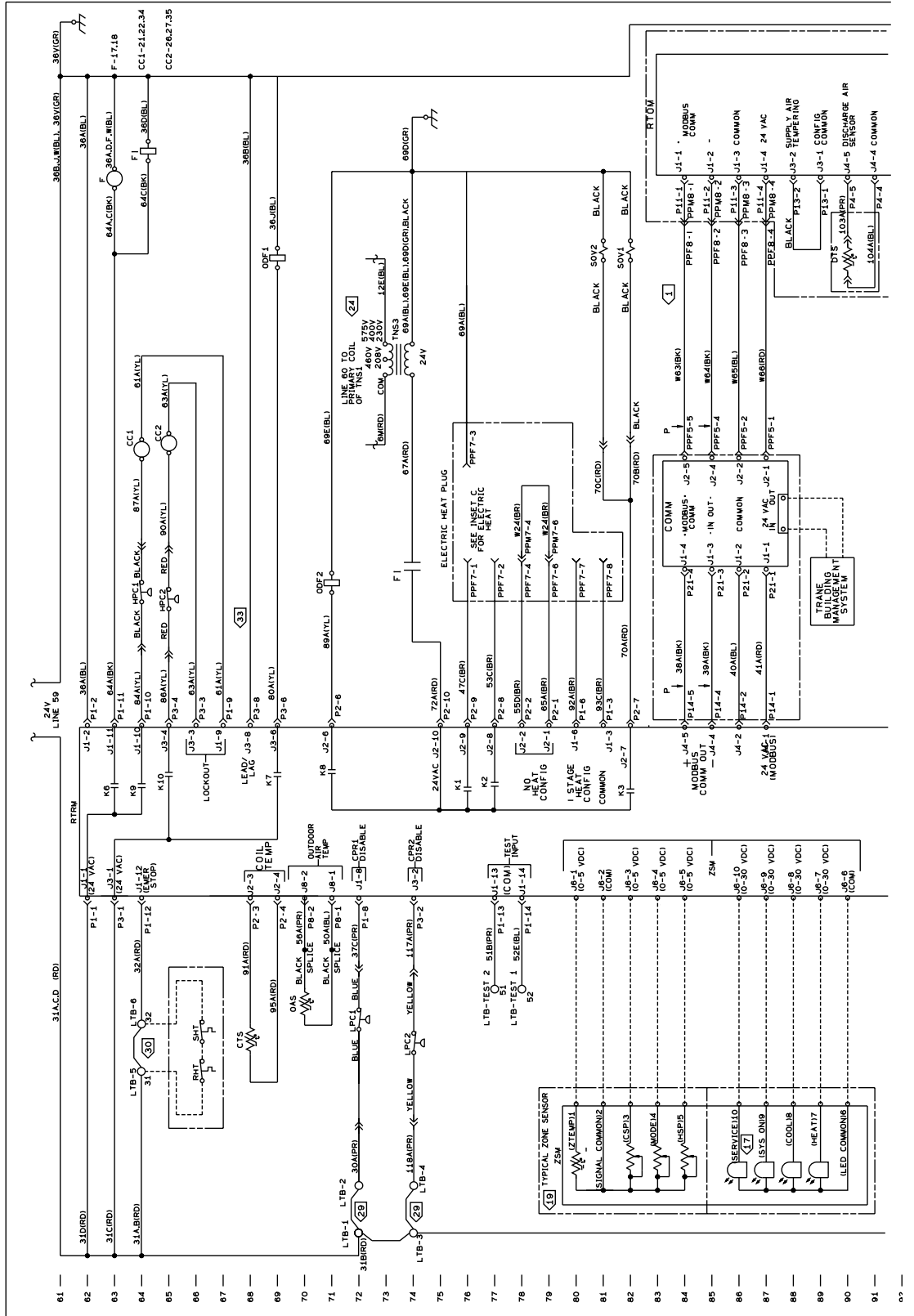

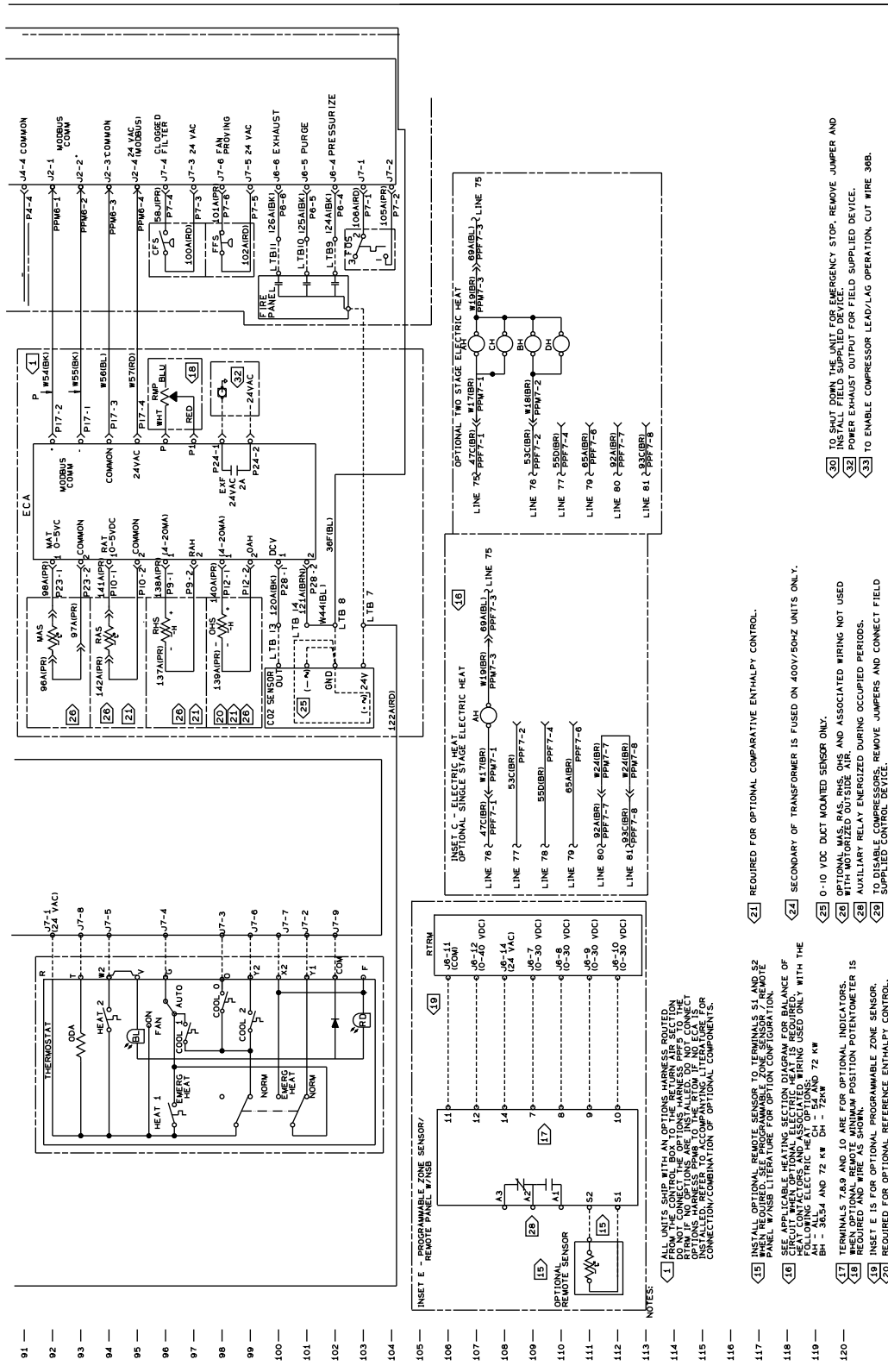

Jobsite Connections

Table 34. Zone sensors - typical number of wires

Zone Sensors	
A	Manual Changeover.....4
	Manual/Auto Changeover.....5
	Manual/Auto Changeover with Status Indication LED's.....10
	Programmable Night Setback with Status Indication LED's.....7
Thermostats	
B	3 Power Wires + 1 Ground Wire (three phase)
	2 Power Wires + 1 Ground Wire (single phase)

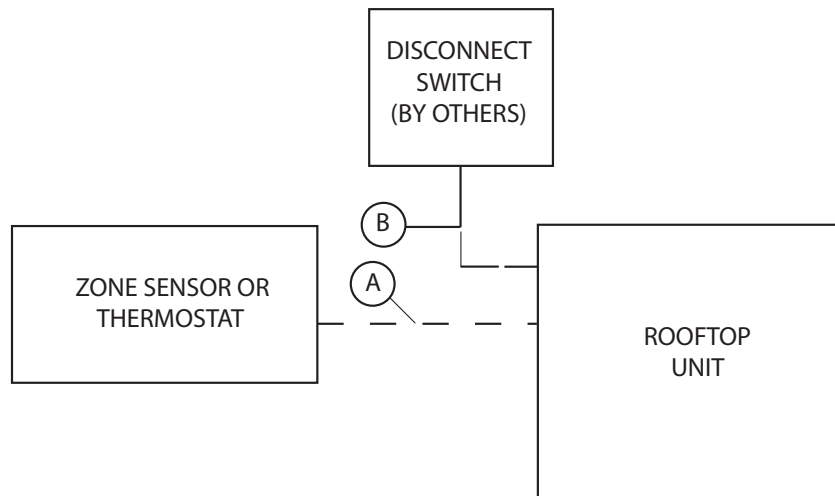

Notes:

- For specific wiring information, see the installation instructions.
- All wiring except power wires is low voltage.
- All customer-supplied wiring should be copper and must conform to NEC or CEC and local electrical codes.
- Wiring shown dotted is to be furnished and installed by the customer.
- Zone sensors are required for units configured for Single Zone VAV indoor fan system control in order to enable Single Zone VAV functionality.

Mechanical Specifications

General

The units shall be dedicated downflow or horizontal airflow. The operating range shall be between 115°F and 0°F in cooling as standard from the factory for all units. Cooling performance shall be rated in accordance with ARI testing procedures. All units shall be factory assembled, internally wired, fully charged with R-410A, and 100% run tested to check cooling operation, fan and blower rotation and control sequence, before leaving the factory. Wiring internal to the unit shall be colored and numbered for simplified identification. Units shall be UL listed and labeled, classified in accordance to UL 1995/C 22.2, 236-05 3rd Edition.

Casing

Unit casing shall be constructed of zinc coated, heavy gauge, galvanized steel. Exterior surfaces shall be cleaned, phosphatized, and finished with a weather-resistant baked enamel finish. Unit's surface shall be tested 500 hours in a salt spray test in compliance with ASTM B117. Cabinet construction shall allow for all maintenance on one side of the unit. In order to ensure a water and air tight seal, service panels shall have lifting handles and no more than three screws to remove.

All exposed vertical panels and top covers in the indoor air section shall be insulated with a 1/2 inch, 1 pound density foil-faced, fire-resistant, permanent, odorless, glass fiber material. The base of the downflow unit shall be insulated with 1/2 inch, 1 pound density foil-faced, closed-cell material. The downflow unit's base pan shall have no penetrations within the perimeter of the curb other than the raised 11/8 inch high supply/return openings to provide an added water integrity precaution, if the condensate drain backs up. The base of the unit shall have provisions for forklift and crane lifting.

Unit Top

The top cover shall be one piece, or where seams exist, double hemmed and gasket sealed to prevent water leakage.

Filters

Two inch standard filters shall be factory supplied on all units. Optional two inch pleated MERV 8 and MERV 13 filters with filter removal tool shall be available.

Compressors

External high pressure cutout shall be provided on all 15 and 20 models. Low pressure switches shall be standard. All units shall have direct-drive, hermetic, scroll type compressors with centrifugal type oil pumps. Motor shall be suction gas-cooled and shall have a voltage utilization range of plus or minus 10% of nameplate voltage. Internal overloads shall be provided with the scroll compressors. Crankcase heaters shall be utilized with all scroll compressors.

Refrigerant Circuits

Each refrigerant circuit shall have independent fixed orifice or thermostatic expansion devices, service pressure ports, and refrigerant line filter driers factory installed as standard. An area shall be provided for replacement suction line driers.

Evaporator and Condenser Coils

Internally finned, 5/16" copper tubes mechanically bonded to a configured aluminum plate fin shall be standard. Coils shall be leak tested at the factory to ensure the pressure integrity. All coils are pressure and leak tested at minimum of 450 psig. The completely assembled refrigerant system is leak tested at a minimum of 240 psig with a refrigerant and nitrogen mixture. All dual compressor units shall have intermingled evaporator coils. Sloped condensate drain pans are standard. Patent-pending 1+1+1 condenser coil, permanently gapped for easy cleaning is available.



Mechanical Specifications

Outdoor Fans

The outdoor fan shall be direct-drive, statically and dynamically balanced, draw-through in the vertical discharge position. The fan motor(s) shall be permanently lubricated and shall have built-in thermal overload protection.

Indoor Fan

Units above shall have belt driven, FC centrifugal fans with adjustable motor sheaves. Units with standard motors shall have an adjustable idler-arm assembly for quick-adjustment of fan belts and motor sheaves. All motors shall be thermally protected. Oversized motors shall be available for high static application. All indoor fan motors meet the U.S. Energy Policy Act of 1992 (EPACT).

Controls

Unit shall be completely factory-wired with necessary controls and contactor pressure lugs or terminal block for power wiring. Unit shall provide an external location for mounting a fused disconnect device. ReliaTel controls shall be provided for all 24-volt control functions. The resident control algorithms shall make all heating, cooling, and/or ventilating decisions in response to electronic signals from sensors measuring indoor and outdoor temperatures. The control algorithm maintains accurate temperature control, minimizes drift from set point, and provides better building comfort. A centralized control shall provide anti-short cycle timing and time delay between compressors to provide a higher level of machine protection.

Defrost Controls

Adaptive demand defrost shall be provided to permit defrost wherever coil icing conditions begin to significantly reduce unit capacity.

Discharge Line Thermostat

A bi-metal element discharge line thermostat is installed as a standard option on the discharge line of each system. This standard option provides extra protection to the compressors against high discharge temperatures in case of loss of charge, extremely high ambient and other conditions which could drive the discharge temperature higher. Discharge line thermostat is wired in series with high pressure control. When the discharge temperature rises above the protection limit, the bi-metal disc in the thermostat switches to the off position, opening the 24 VAC circuit. When the temperature on the discharge line cools down, the bi-metal disc closes the contactor circuit, providing power to the compressor. When the thermostat opens the fourth time, the ReliaTel control must be manually reset to resume operation on that stage.

Phase Monitor

The Phase Monitor is a 3 phase line monitor module that protects against phase loss, phase reversal and phase unbalance. It is intended to protect compressors from reverse rotation. It has an operating input voltage range of 190-600 VAC, and LED indicators for ON and FAULT. There are no field adjustments and the module will automatically reset from a fault condition.

Variable Frequency Drive

Variable Frequency Drives are factory installed and tested to provide supply fan motor speed modulation. VFDs on the supply fan, as compared to inlet guide vanes or discharge dampers, are quieter, more efficient, and are eligible for utility rebates. All VFDs are designed to allow bypass if required. Bypass control will simply provide full nominal airflow in the event of drive failure.

Factory Installed Options

Black Epoxy Pre-Coated Coils

The black epoxy coils have a thermoset vinyl coating that is bonded to the aluminum fin stock prior to the fin-stamping process. The pre-coated coils are an economical option for protection in mildly corrosive environments.

Condensate Overflow Switch

This option shall shut the unit down in the event that a clogged condensate drain line prevents proper condensate removal from the unit.

Fault Detection & Diagnostics (FDD)

This offering meets the mandatory requirement of Title 24. This option provides detection of the following faults: Air temperature sensor failure/fault, not economizing when it should, economizing when it should not, damper not modulating, and excessive outdoor air. The FDD system shall be certified by the Energy Commission as meeting the requirements.

High Efficiency Motors

This option is available with efficiency ratings from 86.5 up to 91.0. It is not available for all models.

High Short Circuit Current Rating

Unit shall be provided with electrical subsystem that will withstand fault currents up to 65kA (208/230, 460 VAC) or 25kA (575 VAC) compliant with UL 1995 and NEC 440.4 (B). Each compressor circuit and the indoor fan shall have dedicated overcurrent protection. Three phase motors shall be protected by Class J time delay fuses. Single phase motors shall be protected by Class CC time delay fuses. All transformers shall also be protected with Class CC time delay fuses. Contactors shall be din rail mounted.

Hinged Access Doors

Sheet metal hinges are available on the Filter, Evaporator, ID Fan and Compressor/Control Access Doors. This option is available on all models.

Horizontal Side Access with Circuit Breaker

This option is a thermal magnetic, molded case, HACR Circuit Breaker with provisions for through the base electrical connections. The circuit breaker will be installed in a water tight enclosure in the unit with access through a swinging door. Factory wiring will be provided from the switch to the unit high voltage terminal block. The circuit breaker will provide overcurrent protection, be sized per NEC and UL guidelines, and be agency recognized by UL/CSA.

Horizontal Side Access with Disconnect Switch

Three-pole, molded case, disconnect switch with provisions for through the base electrical connections are available. The disconnect switch will be installed in the unit in a water-tight enclosure with access through a swinging door. Factory wiring will be provided from the switch to the unit high voltage terminal block. The switch will be UL/CSA agency recognized.

Note: *The disconnect switch will be sized per NEC and UL guidelines but will not be used in place of unit overcurrent protection. This option is available on all models.*

Human Interface

The Human Interface shall have a 5 inch color touchscreen display that conforms to FCC Part 15 Class B with an Ingress Protection Rating of IP24. The display text shall be readable by a person with 20/20 vision at a distance of 3 feet and 60° angle at lighting levels ranging from 100 lux - 25,000 lux. Also, the display shall operate at temperatures of -40° C to 70° C. Firmware and unit configurations shall be able to be restored via a USB storage device.

Mechanical Specifications

Multi-Speed Indoor Fan System

Multi-speed indoor fan system is designed for use in applications for meeting the minimum requirement of CA Title 24. This system incorporates a multi-speed fan control to change the speed of the fan to 67% of full airflow based off of compressor stages.

Powered or Unpowered Convenience Outlet

This option is a GFCI, 120v/15amp, 2 plug, convenience outlet, either powered or unpowered. When the convenience outlet is powered, a service receptacle disconnect will be available. The convenience outlet is powered from the line side of the disconnect or circuit breaker, and therefore will not be affected by the position of the disconnect or circuit breaker. This option can only be ordered when the Through the Base Electrical with either the Disconnect Switch, or Circuit Breaker, option is ordered. This option is available on all models.

Single Zone VAV

SZVAV systems combine Trane application, control and system integration knowledge to exactly match fan speed with cooling and heating loads, regardless of the operating condition.

Stainless Steel Drain Pan

This option provides excellent corrosion and oxidation resistance. Drain pan shall be constructed of 304 stainless steel.

Supply, Return and Plenum Air Smoke Detector

With this option installed, if smoke is detected, all unit operation will be shut down. Reset will be manual at the unit. Return Air Smoke Detectors require minimum allowable airflow when used with certain models. See the Installation, Operation, and Maintenance (IOM) manual for the models affected and the minimum allowable airflow required. This option is available on all downflow models. Supply and/or Return Detectors may not be used with the Plenum Smoke Detector.

Through the Base Electrical with Circuit Breaker

This option is a thermal magnetic, molded case, HACR Circuit Breaker with provisions for through the base electrical connections. The circuit breaker will be installed in a water tight enclosure in the unit with access through a swinging door. Factory wiring will be provided from the switch to the unit high voltage terminal block. The circuit breaker will provide overcurrent protection, be sized per NEC and UL guidelines, and be agency recognized by UL/CSA.

Through the Base Electrical with Disconnect Switch

Three-pole, molded case, disconnect switch with provisions for through the base electrical connections are available. The disconnect switch will be installed in the unit in a water-tight enclosure with access through a swinging door. Factory wiring will be provided from the switch to the unit high voltage terminal block. The switch will be UL/CSA agency recognized.

Note: *The disconnect switch will be sized per NEC and UL guidelines but will not be used in place of unit overcurrent protection. This option is available on all models.*

Through the Base Utilities Access

An electrical service entrance shall be provided allowing electrical access for both control and main power connections inside the curb and through the base of downflow units, and through the front of the horizontal units. Option will allow for field installation of liquid-tight conduit and an external field-installed disconnect switch.

Two-Inch Pleated Filters

Two inch pleated MERV 8 or MERV 13 filters with filter removal tool shall be available on all models.

Factory or Field Installed Options

BACnet™ Communications Interface

This option shall be provided to allow the unit to communicate directly with a generic open protocol BACnet MS/TP Network Building Automation System Controls.

Barometric Relief

This option shall provide a pressure operated damper for the purpose of space pressure equalization and be gravity closing to prohibit entrance of outside air during the equipment “off” cycle.

Clogged Filter/Fan Failure Switch

A dedicated differential pressure switch is available to achieve active fan failure indication and/or clogged filter indication. These indications will be registered with either a zone sensor with status indication lights or an Integrated Comfort™ System.

Differential Pressure Switches

These options allow for individual fan failure and dirty filter indication. The fan failure switch will disable all unit functions and “flash” the Service LED on the zone sensor. The dirty filter switch will light the Service LED on the zone sensor and will allow continued unit operation.

Discharge Air Sensing Kit

This kit provides true discharge air sensing in heating models. This sensor is a status indicator readable through Tracer™ or Tracker™. The kit is functional only with the ReliaTel Options Module.

Economizer - Standard, Downflow

The assembly includes fully modulating 0-100% motor and dampers, barometric relief, minimum position setting, preset linkage, wiring harness with plug, fixed dry bulb and spring return actuator. The barometric relief damper shall be standard with the downflow economizer and shall provide a pressure operated damper that shall be gravity closing and shall prohibit entrance of outside air during the equipment “off” cycle. Solid state enthalpy and differential enthalpy control shall be field-installed.

Economizer - Low Leak, Downflow

This accessory meets low leak requirements for ASHRAE 90.1, IECC, and CA Title 24 standards (3 cfm/ft²@1" wg exterior air, 4 cfm/ft²@1" wg return air). This option allows 100% outdoor air supply from 0-100% modulating dampers and is standard with barometric relief. It can be paired with powered exhaust for additional building pressure relief. This option can be paired with or without Fault Detection & Diagnostics (FDD) to meet current mandatory CA Title 24 requirements. Available on downflow units only. The economizers come with three control options, dry bulb and reference or comparative enthalpy (optional).

Electric Heaters

Electric heat modules shall be available for installation within the basic unit. Electric heater elements shall be constructed of heavy-duty nickel chromium elements internally delta connected for 240 volt, wye connected for 480 and 600 volt. Staging shall be achieved through ReliaTel. Each heater package shall have automatically reset high limit control operating through heating element contactors. All heaters shall be individually fused from the factory, where required, and shall meet all NEC and CEC requirements when properly installed. Power assemblies shall provide single-point connection. Electric heat modules shall be UL listed or CSA certified. If ordering the Through the Base Electrical option with an Electric Heater, the heater must be factory installed.



Mechanical Specifications

Frostat™

This option is to be utilized as a safety device. The Frostat opens when temperatures on the evaporator coil fall below 10°F. The temperature will need to rise to 50°F before closing. This option should be utilized in low airflow or high outside air applications.

Indoor Fan Motor Shaft Grounding Ring

Shaft grounding rings are used on all VFD driven motors to provide a conductive discharge path away from the motor bearings to ground. Bearing Protection Ring shall be maintenance free circumferential ring of conductive micro fibers that discharges voltages to ground.

LonTalk® Communications Interface

The LonTalk communications interface, when installed in a Voyager unit, allows the unit to communicate as a Tracer™ LCI-V device or directly with generic LonTalk Network Building Automation System Controls.

Oversized Motors

Oversized motors shall be available for high static applications.

Reference or Comparative Enthalpy

Reference Enthalpy is used to measure and communicate outdoor humidity. The unit receives and uses this information to provide improved comfort cooling while using the economizer. Comparative Enthalpy measures and communicates humidity for both outdoor and return air conditions and return air temperature. The unit receives and uses this information to maximize use of economizer cooling, and to provide maximum occupant comfort control. Reference or Comparative Enthalpy option shall be available when a factory or field installed Downflow Economizer is ordered. This option is available on all downflow models.

Tool-less Hail Guards

Tool-less, hail protection quality coil guards are available for condenser coil protection.

Trane Communication Interface

This factory or field-installed option shall be provided to interface ReliaTel™ controlled units with the Trane Integrated Comfort™ systems.

Field Installed Options

CO₂ Sensor

The CO₂ sensor shall have the ability to monitor the concentration (parts per million, ppm) of CO₂ (Carbon Dioxide) in the air. As the CO₂ concentration changes, the outside air damper modulates to meet the current ventilation needs of the zone.

Note: Choose factory-installed CO₂ sensor wiring option to save time and ensure proper unit connections for the field installed CO₂ sensor kits.

Digital Display Zone Sensor

The Digital LCD (Liquid Crystal Display) zone sensor has the look and functionality of standard zone sensors. This sensor includes a digital display of set point adjustment and space temperature in °F (Fahrenheit) or °C (Celsius). Includes FAN and SYSTEM buttons (supports the service functions of the standard sensor). E-squared memory stores last programmed set points. Requires 24 VAC (Volts AC). This sensor should be utilized with ReliaTel™ controls.

Economizer - Standard, Horizontal

The horizontal economizer shall contain the same features as the downflow economizer with the exception of barometric relief.

Economizer - Low Leak, Downflow

This accessory meets low leak requirements for ASHRAE 90.1, IECC, and CA Title 24 standards (3 cfm/ft²@1" wg exterior air, 4 cfm/ft²@1" wg return air). This option allows 100% outdoor air supply from 0-100% modulating dampers and is standard with barometric relief. It can be paired with powered exhaust for additional building pressure relief. Available on downflow units only.

High Static Drive

The high static drive option shall allow the standard motor on the 12½ and 15 ton units to operate with improved external static capabilities.

Manual Outside Air Damper

The rain hood and screen shall provide up to 25% outside air.

Motorized Outside Air Dampers

Manually set outdoor air dampers shall provide up to 50% outside air. Once set, outdoor air dampers shall open to set position when indoor fan starts. The damper shall close to the full closed position when indoor fan shuts down.

Powered Exhaust

The powered exhaust shall provide exhaust of return air, when using an economizer, to maintain better building pressurization.

Roof Curb - Downflow

The roof curb shall be designed to mate with the downflow unit and provide support and a water tight installation when installed properly. The roof curb design shall allow field-fabricated rectangular supply/return ductwork to be connected directly to the curb. Curb design shall comply with NRCA requirements. Curb shall be shipped knocked down for field assembly and shall include wood nailer strips.

Remote Potentiometer

The minimum position setting of the economizer shall be adjusted with this accessory.

Ventilation Override Accessory

With the Ventilation Override Accessory installed, the unit can be set to transition up to three different pre-programmed sequences for Smoke Purge, Pressurization, and Exhaust. The transition occurs when a binary input on the RTOM is closed (shorted). This would typically be a hard wired relay output from a smoke detector or fire control panel.

Zone Sensors

This option shall be provided to interface with Voyager units and shall be available in either manual, automatic, programmable with night setback, with system malfunction lights or remote sensor options.

Note: *Zone sensors are required for units configured for Single Zone VAV indoor fan system control to enable Single Zone VAV functionality.*



Trane optimizes the performance of homes and buildings around the world. A business of Ingersoll Rand, the leader in creating and sustaining safe, comfortable and energy efficient environments, Trane offers a broad portfolio of advanced controls and HVAC systems, comprehensive building services, and parts. For more information, visit www.Trane.com.

Trane has a policy of continuous product and product data improvement and reserves the right to change design and specifications without notice.