

# Altum AC Installation Quick Start Guide

## Overview

The Altum AC comes in three different configurations; A600-EXT, A600-19, and A600-25. This guide will illustrate how to install the Altum AC unit after configuring the unit on the bench.

### Installing A600-25

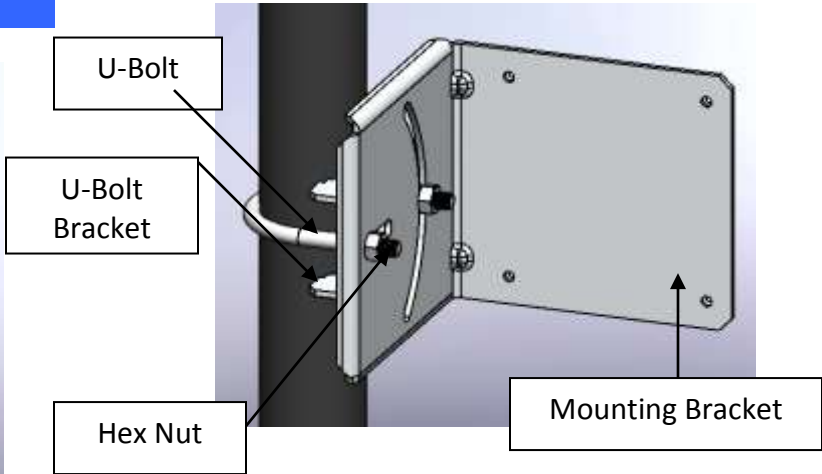
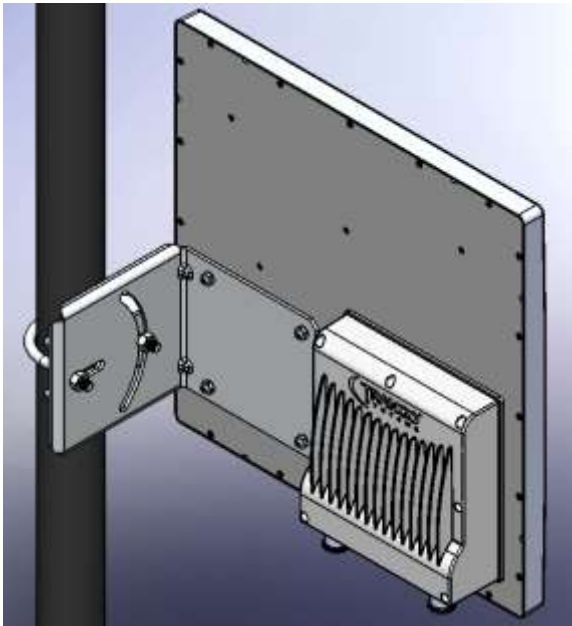

2. Install the Altum AC radio unit by sliding the (4) protruding threads on the back plate through the mating holes on the mounting bracket. Secure the unit with the (4) 10-32 kep nuts. Skip to step 3.

In the A600-25 box you will find the following parts:

- (1) U-Bolt with hex nuts
- (1) Mounting Bracket
- (1) Port Plug
- (1) U-Bolt bracket
- (1) Port Plate with captive screws
- (4) 10-32 kep nuts
- (1) POE injector

1. For easiest installation install the mounting bracket onto the 1.5-2.5 inch diameter pole using the U-bolt and the U-bolt bracket. Tilt the bracket to the approximate desired angle before tightening the hex nuts onto the U-bolt.

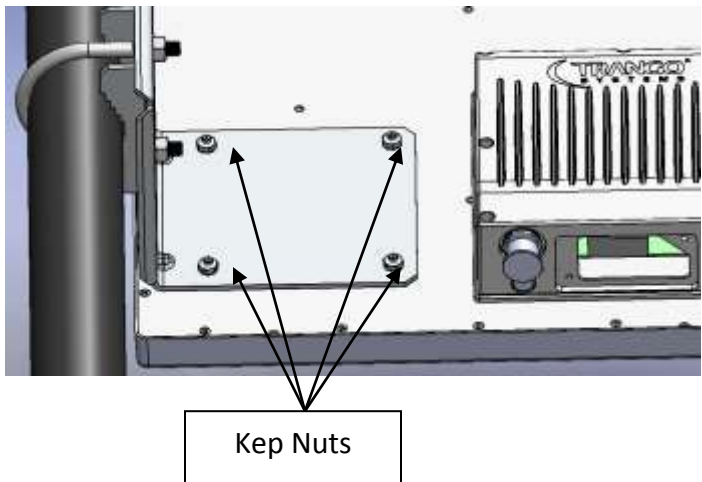

## Installing A600-19

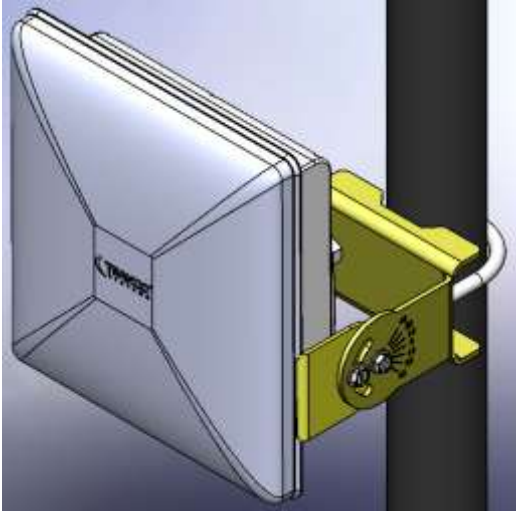

In the A600-19 box you will find the following parts:

- (1) U-Bolt with hex nuts
- (2) ¼-20 hex head screws
- (1) Mounting Bracket
- (1) Altum AC 19 dBi unit
- (1) Port Plug
- (1) Port Plate with (2) captive screws
- (1) POE injector

1. Install the Mounting Bracket by feeding the U-Bolt through the holes and tightening using the included hex nuts.

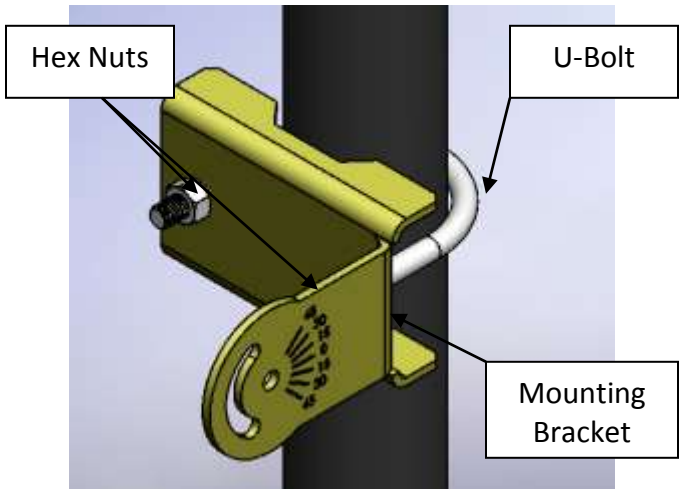

2. Install the A600-19 radio using the ¼-20 hex head screws. Skip to step 3.

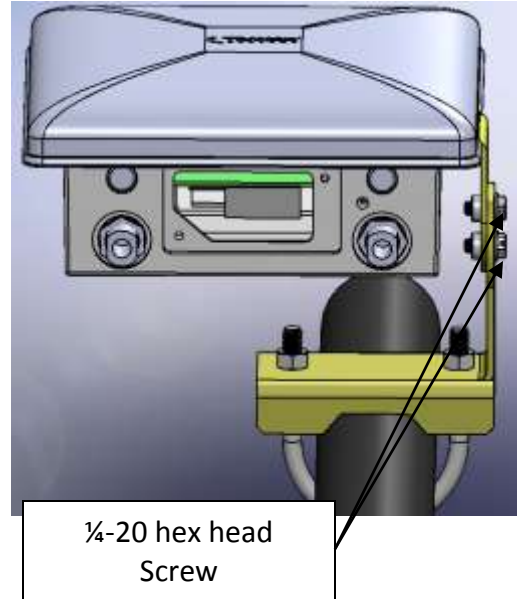

## Installing A600-EXT

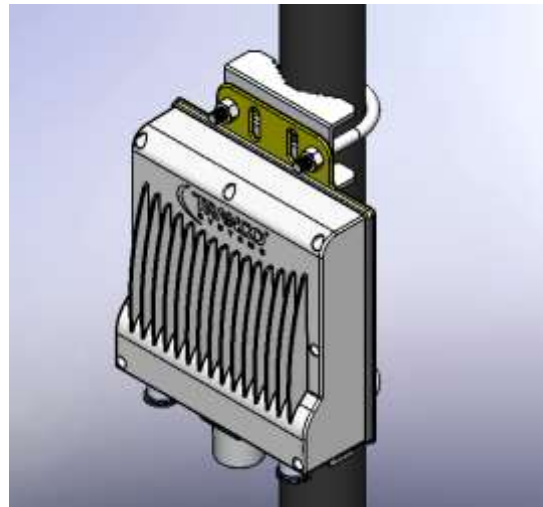

In the A600-EXT box you will find the following parts:

- (2) U-Bolt with hex nuts
- (2) Mounting Brackets
- (1) Port Plug
- (1) Port Plate with (2) captive screws
- (1) POE injector
- (1) Connector Sealing Tape Packet

1. Feed the U-bolts through the mounting brackets and then through the back plate before securing using the hex nuts.

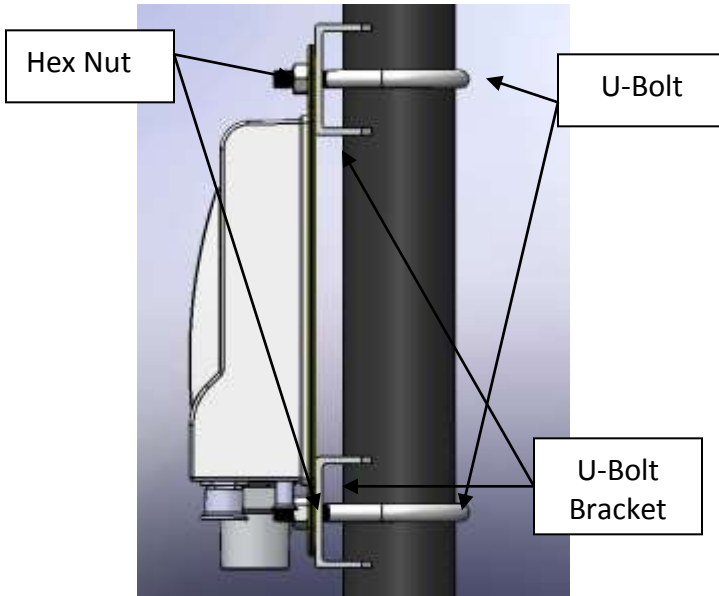

### Getting Altum AC Ready for Power Up

3. Plug in The Ethernet cables and install them into the port plug as shown.  
*Note: The LAN port is on the "right" side as you look into the unit, while the WAN port is on the "left"*

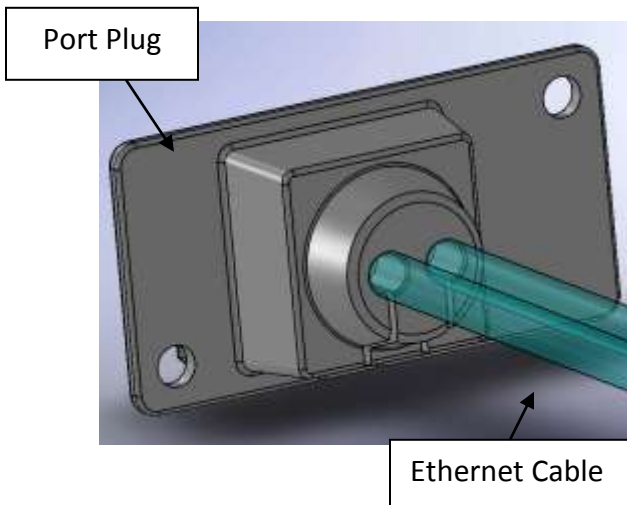

4. Install the Port Plug as seen below.

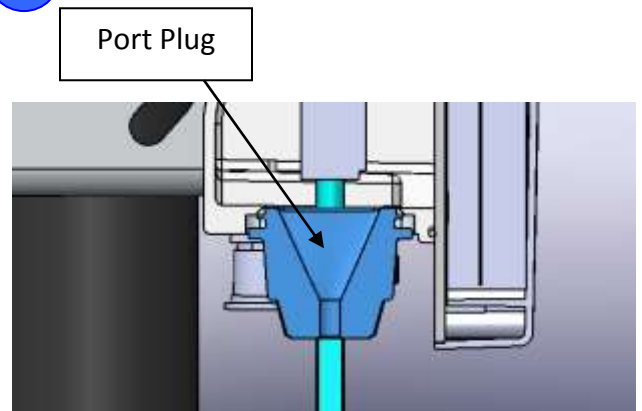

5. Feed the Ethernet cable(s) through and attach the Port Plate using the (2) captive screws. Tighten until snug.

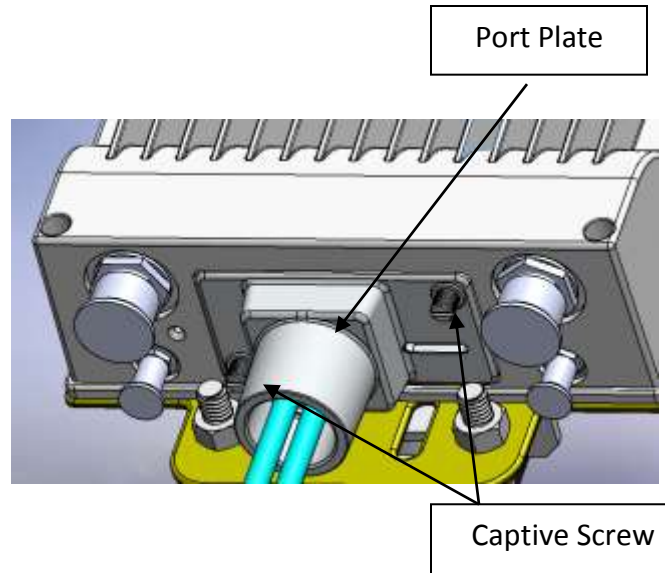

7. Plug the Ethernet cables into the POE injector power supply as shown below.  
*Note: the POE and LAN ports are also labeled on the power supply.*



POE to Radio

LAN

- 8. (Optional) Remove the caps from the N-connectors and attach (2) 2.4 GHz wifi antennas with N-Male connectors.

*Note: Do not remove connector caps unless you will be using the 2.4 GHz radio.*



2.4 GHz Antenna

- 9. For EXT model only. Remove the SMA-RP connector caps and attach cables to the external antenna. Make sure to use cables with SMA-RP or damage/low signal levels may result. Apply Connector Sealing Tape around the connections to seal from weather.

**NOTE: Altum AC must be installed by trained personnel to ensure compliance with local/regional building codes and Wireless regulations.**

### About Trango Systems, Inc.

Trango Systems, Inc., was founded in 1996 and is headquartered in San Diego County, California. The company designs and manufactures innovative licensed and



unlicensed microwave backhaul equipment for customers in over 70 countries and is ISO 9001:2008 certified.