



**TrangoLINK-10™**

**Wireless Ethernet Bridge**

**PROFESSIONAL INSTALLATION GUIDE**

**-draft-**

## Overview

This manual covers basic configuration and installation of the TrangoLINK-10-EXT system which consists of two radios, M5830S-MU-EXT (Master Unit) and M5830S-RU-EXT (Remote Unit). Since these devices require manual maximum power limit settings (for 5.25-5.35 GHz U-NII band operation only), they are classified by the FCC as a professional install devices. To be in compliance with FCC guidelines, the radios must be installed with one of several approved antennas listed in this document.

The M5830S-MU-EXTR and M5830S-RU-EXT are currently FCC certified for use with three external antennas.

Antenna Part #	Description	Gain
AD5830-24-D	18" DSS Dish	24 dBi
AD5830-23-D	15" Flat Panel	24 dBi
SPD3-5.2	3' Dish from Radiowaves	30 dBi

The M5830S-MU-EXT Master Unit works in conjunction with the M5830S-RU-EXT Remote Unit. Please see the TrangoLINK-10 User Manual for general information on overall system implementation, configuration, and management of these radios. The TrangoLINK-10 User Manual also covers many important aspects of radio configuration and management which is applicable to the TrangoLINK-10-EXT.

## FCC Information

This device complies with Part 15 of FCC Rules and Regulations. Operation is subject to the following two conditions: (1) This device may not cause harmful interference and (2) this device must accept any interference received, including interference that may cause undesired operation.

This equipment has been tested and found to comply with the limits for a Class B digital device, pursuant to Part 15 of the FCC Rules. These limits are designed to provide reasonable protection against harmful interference in a residential installation. This equipment generates, uses, and can radiate radio-frequency energy and, if not installed and used in accordance with these instructions, may cause harmful interference to radio communications. However, there is no guarantee that interference will not occur in any particular installation. If this equipment does cause harmful interference to radio or television reception, which can be determined by turning the equipment off and on, the user is encouraged to correct the interference by one of more of the following measures:

- 1) Reorient the antenna;
- 2) Increase the separation between the affected equipment and the unit;
- 3) Connect the affected equipment to a power outlet on a different circuit from that which the receiver is connected to;
- 4) Consult the dealer and/or experienced radio/TV technician for help.

**FCC ID: NCYM5830SSUEXT**

**Canada: to be announced soon**

### IMPORTANT NOTE:

Intentional or unintentional changes or modifications must not be made unless under the express consent of the party responsible for compliance. Any such modifications could void the user's authority to operate the equipment and will void the manufacturer's warranty. To comply with FCC RF exposure requirements, the following antenna installation and device operating configurations must be satisfied. The antenna for this unit must be fixed and mounted on outdoor permanent structures with a separation distance of at least two meters from all persons. Furthermore, it must not be co-located or operating in conjunction with any other antenna or transmitter.

## Warranty Information

Radios from Trango Broadband Wireless are warranted from one year from date of purchase. Please see [www.trangobroadband.com](http://www.trangobroadband.com) for complete description of warranty coverage and limitations.

## General Information

### Contents

Each TrangoLINK-10-EXT kit comes equipped with a Master Unit (MU) and Remote Unit (RU), two power-over-Ethernet (PoE) J-Boxes, two AC adapters, and two mounting kits. The MAC ID and Serial # are printed on a label on the back of the radio.

### Antenna Connections

The radio is equipped with two reverse-polarity SMA connectors on the side for attachment to an external antenna. Each SMA connector is labeled with either “V” for Vertical or “H” for Horizontal polarization.

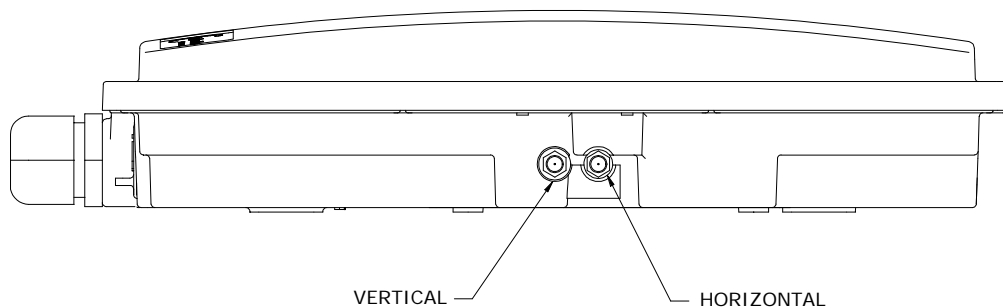

Connect each cable to the appropriate vertical and horizontal ports on both the antenna and the radio.

### Ethernet / Power Connections

See the TrangoLINK-10 User Manual for detailed diagram for connecting radio to network or PC utilizing the power over Ethernet (PoE) J-Box and cat-5 cables.

**! IMPORTANT: DO NOT APPLY DC POWER TO THE RADIO UNTIL THE ANTENNA IS ATTACHED OTHERWISE DAMAGE TO THE RADIO MAY OCCUR.**

### Setting the Maximum RF Power

The FCC allows a maximum EIRP of 1 watt (30 dBm) for devices transmitting in the 5.25 to 5.35 U-NII band. The M5830S-MU-EXT and M5830S-RU-EXT's factory default maximum power settings for this band is +6 dBm. If the radio is to be equipped with Trango standard antennas AD5830-23-D or AD5830-24-D, no manual adjustment to the max power setting is required since radio power output plus antenna gain does not exceed 30 dBm.

**However, due to FCC restrictions the professional installer must manually reduce the maximum power for the 5.25 to 5.35 GHz U-NII band if a higher gain antenna is to be used.**

The table below shows the maximum power setting for the radio to achieve an EIRP of 1 watt (FCC limit). Only the antennas listed below are FCC Certified for use with the TrangoLINK-10-EXT.

<b>Antenna Model</b>	<b>Antenna Gain (incl/cable loss)</b>	<b>Radio Max power setting</b>
AD5830-23-D	+24 dBi	+6 dBm
AD5830-24-D	+24 dBi	+6 dBm
SPD3-5.2	+30 dBi	0 dBm

✍ Note: that in all cases, Antenna Gain + Radio Max Power Setting is 30 dBm. Once set, the power leveling feature will still operate normally, but the maximum EIRP will never exceed 1 watt (30 dBm).

The Max Power Setting command is only accessible from the command line and is not available on the HTTP Browser interface.

The telnet or serial port command to change the maximum power is:

***uniimaxpower <max power in dBm>***

The flash memory must be updated after running the command. ***save systemsetting***

The command must be run prior to installing the antenna and while the Opmode is OFF.

Example: To set the max power setting for the AD5830-23-D:

```
#> uniimaxpower 6
#> save systemsetting
```

✍ Note: The maximum RF power may be left at +22 dBm for the 5.725 to 5.85 GHz ISM band regardless of which FCC Certified antenna is used. No manual setting is required.

## Radio Hardware Installation

The M5830S-MU-EXT and M5830S-RU-EXT may be installed on a pole or a flat surface per the drawings below:

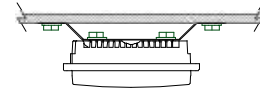
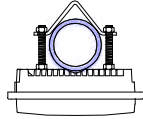

POLE MOUNTING

WALL MOUNTING

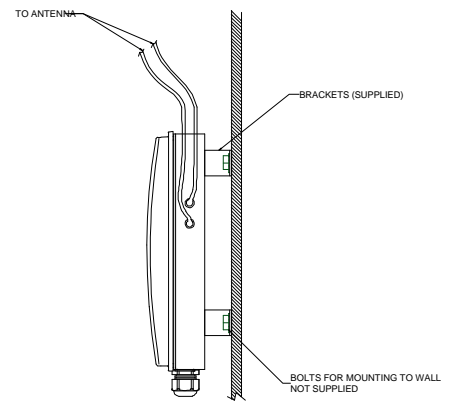
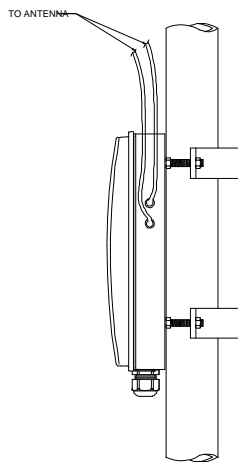

Radios should always be mounted with Ethernet and RJ11 ports at the bottom. See the TrangoLINK-10 User Manual for grounding and additional weatherproofing guidelines. In addition to the guidelines listed in the TrangoLINK-10 User Manual, installers must cover cable-SMA connectors (both ends) with heat-shrink to provide weatherproofing of the RF cable connectors.

### AD5830-24-D DSS STYLE ANTENNA

See diagram below for proper installation of the AD5830-24-D These antennas are designed primarily for low rise building installations only. Do not install in an area where high (>70 mph) winds are expected. **NOTE: Optimal alignment of this dish (to radio at horizon) is 20° below vertical.**

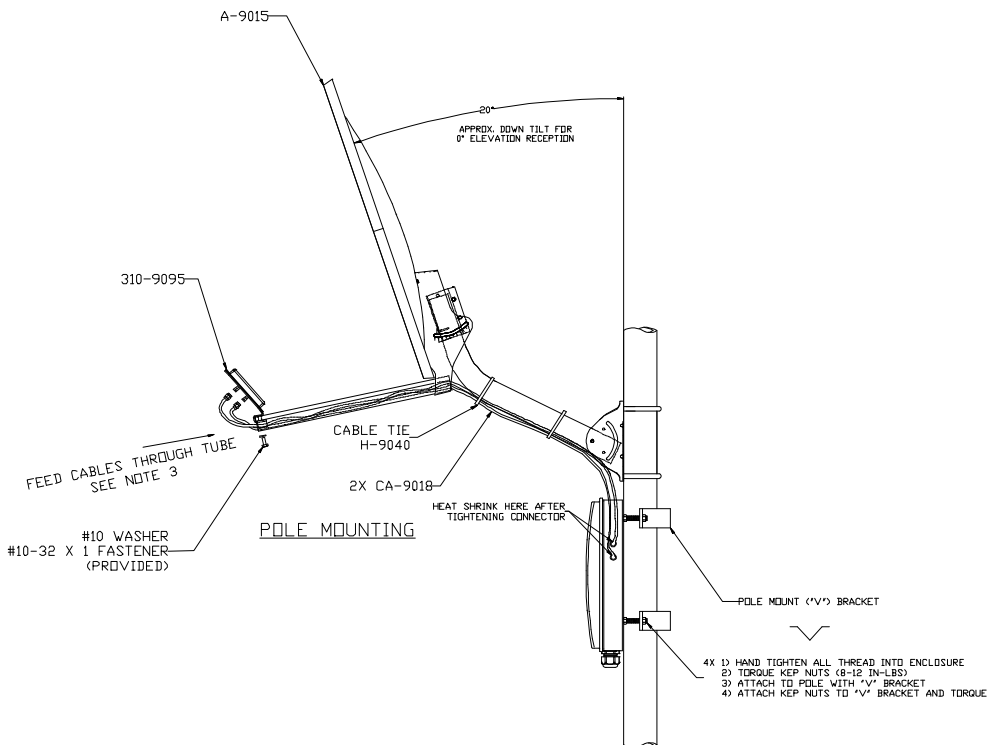
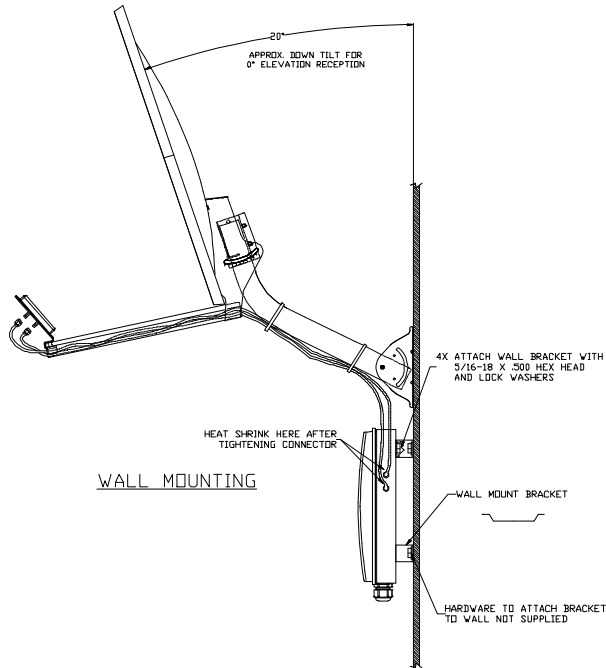

### AD5830-23-D PANEL ANTENNA

To install the AD5830-23-D Panel antenna please see the drawing below:

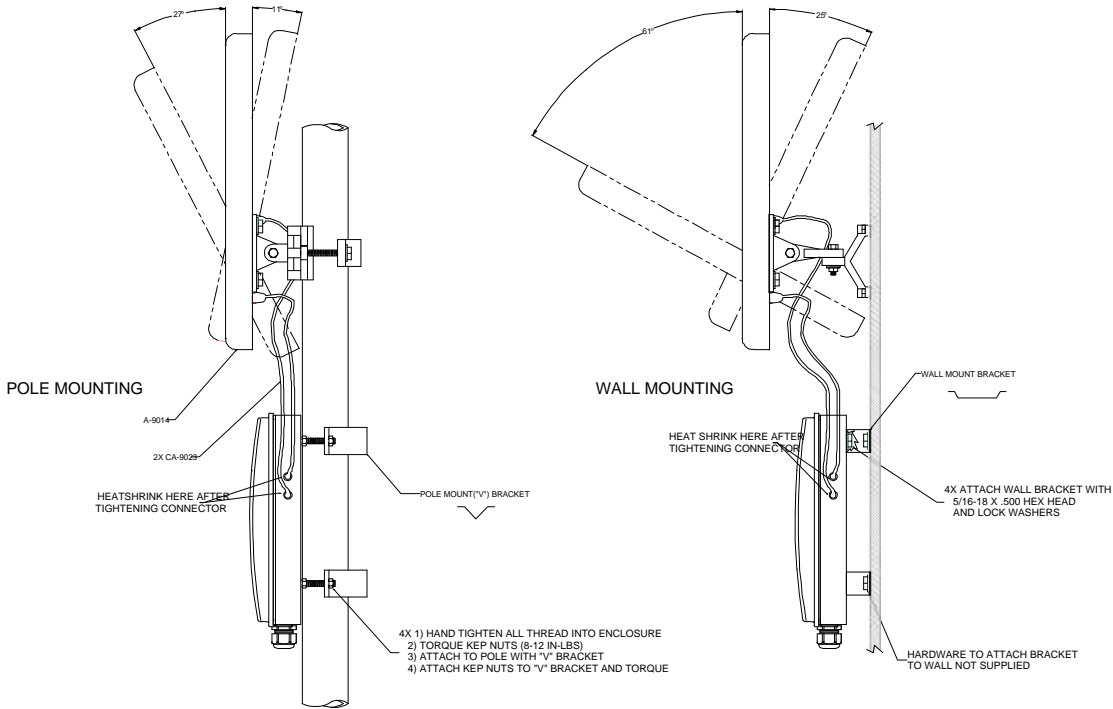

### RADIOWAVES SPD3-5.2 PRIME FOCUS DISH ANTENNAS

The SPD3-5.2 from Radiowaves, Inc. is a parabolic prime focus dish antenna designed for long range applications and tower installations. These antennas are designed for superior performance in long range applications and tower installations that may be subject to high winds. Radomes are available from Radiowaves for installations subject to extreme weather. Contact Radiowaves, Inc. ([www.radiowavesinc](http://www.radiowavesinc)) for more information.

The SPD3-5.2 is equipped with a standard "N" Female RF Connector interface. A special cable assembly is required to connect this antenna to the Trango M5830S-SU-EXT's reverse polarity SMA Female connector.

Recommended Cable Assembly:

REVERSE POLARITY SMA MALE TO STANDARD N MALE  
50 OHM, RG142B/U COAX, DOUBLE SHIELDED. Length: 24" – 48".



Note: To minimize loss, use the shortest cable length possible.

Pre-Assembled Cable Assemblies are available from Pasternack Enterprises [www.pasternack.com](http://www.pasternack.com).

**Model No. PE34361-24**                      24" REVERSE POLARITY SMA MALE TO STANDARD N MALE

**Model No. PE34361-36**                      36" REVERSE POLARITY SMA MALE TO STANDARD N MALE

**Model No. PE34361-48**

46" REVERSE POLARITY SMA MALE TO STANDARD N MALE

See the Radiowaves SPD3-5.2 User's Manual for detailed hardware installation instructions.

## Remote Unit Antenna Alignment

To align the RU antenna for optimal performance, follow the procedure outlined in the TrangoLINK-10 User Manual. This procedure is also included below for your convenience. The same procedure applies to both the P5830S-RU and the P5830S-RU-EXT.

Once the RU's antenna is mounted and aimed in the general direction of the MU, it is time to perform an RSSI test to determine the signal strength from the MU, and to precisely align the RU antenna for maximum signal strength.

### RU Antenna Alignment Procedure

1. Ensure MU is in opmode "ON"
2. Telnet into the RU (while in opmode "OFF") or access the radio via hyperterminal/serial port.
3. Type command **RSSI <channel> <polarization>** - Example **RSSI 3 V** (chan. 3, vertical polarization)
4. Telnet session screen will begin a continuous readout of the received signal strength.
5. As you read the RSSI reading, move the antenna in the horizontal and vertical planes until the maximum RSSI reading is achieved. For short links you can expect an RSSI of -60 dBm or better. For longer links and RSSI of -75 dBm is acceptable. Any RSSI of less than -80 dBm may be too weak for the radios to reliably associate and pass data.
6. If it is not possible to receive an adequate RSSI reading, it may be necessary to reorient the MU (up/down, left/right), to increase the output power of the MU, or to move the RU to a location with better line-of-sight conditions to the MU.

Once you are satisfied with the RSSI reading, tighten down the antenna in the optimum position. To stop the RSSI continuous readout, hit SPACE ENTER.

✍ Note: The amber light on the bottom of the RU will also indicate RSSI according to the following parameters:

RSSI $\leq$ -80dBm	not lit
RSSI > -80dBm	blinking.
RSSI ? -65dBm	solid. (blink rate increases with signal strength.)



## Specifications

### Radio Transmit Specifications

Frequencies:

Storable Channels: 30 memory locations

Channel spacing: Low Band: 5.260 to 5.340 GHz in 1 MHz channel increments

High Band: 5.736 to 5.836 GHz in 1 MHz channel increments

Default Channels-

Channel 1: 5.736 GHz

Channel 2: 5.756 GHz

Channel 3: 5.776 GHz

Channel 4: 5.796 GHz

Channel 5: 5.816 GHz

Channel 6: 5.836 GHz

Channel 7: 5.260 GHz

Channel 8: 5.280 GHz

Channel 9: 5.300 GHz

Channel 10: 5.320 GHz

Channel 11: 5.340 GHz

Channel 12-30: Un-programmed

Radio RF Conducted Power:	Low Band:	Max: +6 dBm +/- 2 dB Min: -8 dBm +/- 2 dB
	High Band:	Max: +22 dBm +/- 2 dB Min: -8 dBm +/- 2 dB

EIRP Max: +52 dBm High band with SPD3-5.2 antenna, +46 dBm with 24 dBi antenna.  
+30 dBm Low band Maximum (all antennas)

Freq. Stability: .00025 % PLL Stabilized (2.5 ppm) over temp

Freq. Plan: Single upconversion, 480 MHz IF

Modulated BW: 22 MHz (null to null, 20 dB)

2<sup>nd</sup> Harmonic atten: Per CFR47 part 15.205

LO Supression: Per CFR47 part 15.205

Symbol Rate: 1.375 MSPS

Error Correction: None

Modulation: 1 Mbps DBPSK for header, 11 Mbps CCK spread spectrum for payload

### Receiver Section

Cascade Noise Figure: < 6 dB

Sensitivity: - 83 dBm typical-1600 byte packet

(1E10-6 BER) - 87 dBm typical-64 byte packet

Adj. Channel Rejection: > 20 dB for 10 % PER

Image Rejection: > 60 dB for 10% PER

Frequency Plan: Single conversion, IF at 480 MHz

LO stability: .00025% PLL stabilized (+/-2.5ppm) over temperature range

### Data Input Section

Data Rate (User): Up to 10 Mbps Sustained throughput

Format: 10/100 BaseT IEEE 802.3 Ethernet compliant

Ethernet packet: Up to 1600 byte long packets

### Power

Input Voltage: Input voltage range at unit is 10.5 VDC to 24 VDC max

Power is supplied on Ethernet cable using junction box provided with up to 330 foot 24 AWG STP cable.

Current Cons.: 575 mA in transmit mode at max power using 20 V standard adapter (11.5W)  
500 mA in receive mode using 20 V standard adapter (10 W)

### **Data Output Section**

Data Rate (User): 10 Mbps Maximum sustained throughput  
Format: 10/100 BaseT IEEE 802.3 Ethernet compliant  
Ethernet Protocols: TCP/IP, Telnet, TFTP, UDP, HTTP

### **Physical Interfaces**

Serial Interface: Shielded RJ11 connector  
LAN Interface: Shielded RJ45 connector  
Power: Carried on 4 unused pins of Ethernet cable

### **Mechanical and Environmental**

General Material: Powdercoated Aluminum base with polycarbonate radome  
Size: 12.5"x5"x8" including mounting studs  
Weight: 4 lb  
Mounting: Custom mounting bracket with azimuth-elevation adjustment.

### **Environmental**

Operating Temp: -40 to 60 deg C  
Storage: -40 to 85 deg C  
NEMA Rating: NEMA 4

### **Standard Power Supply**

20 Volt DC Power adapter and J-Box supplied with product.

Type: Linear wall mount transformer  
Input: 120 VAC  
Output: 20 VDC +/- 1 V  
Max current: 1200 mA

### **FCC Compliance**

Subpart B  
Class B Digital device verification

Subpart C

FCC 15.203 Antenna connection requirement – non-standard connection  
FCC 15.209 Unwanted emissions below 1GHz -  
FCC 15.207(a) AC conducted emissions 450Khz to 30 MHz  
FCC 15.205 Restricted bands (LO and harmonics)= 54 dBuV average @3 meters  
EN 301 489-1 Part 7.2 - RF Immunity

### **AD5830-24-D DSS Style dish for M5830S-SU-EXT**

Type DSS Offset (Satellite TV style) 18" (see drawing)  
Polarization Vertical, horizontal electronically selectable  
Frequency 5.2 to 5.9 GHz  
Gain +24 dBi  
Azimuth Beamwidth 9 degrees  
Elevation Beamwidth 9 degrees  
Mount Standard DSS Style U-Bolt Mount

### **AD5830-23-D Patch Antenna for M5830S-SU-EXT**

Type Patch - 15" Square

Polarization	Vertical, horizontal electronically selectable
Frequency	5.2 to 5.9 GHz
Gain	+24 dBi
Azimuth Beamwidth	9 degrees
Elevation Beamwidth	9 degrees
Mount	Heavy Duty Universal Mount.

**Radio Waves SPD3-5.2 Parabolic Dish for M5830S-SU-EXT**

Type	Parabolic Prime Focus 36" Dish
Polarization	Vertical, horizontal electronically selectable
Frequency	5.2 to 5.9 GHz
Gain	+31 dBi (30 dBi with Cable Loss)
Azimuth Beamwidth	4.2 degrees
Elevation Beamwidth	4.2 degrees
Cross Polarization	30 dB
Front/Back Ratio	40 dB