



Atlas5010
Point-to-Point
Wireless OFDM Ethernet Bridge
USER MANUAL

DRAFT

March 15, 2005
Revision xx

for Firmware 1.0a4

Table of Contents	
Preface	iv
FCC Information	iv
Warranty Information	iv
Contact Information	iv
Chapter 1 Overview	1
OFDM	1
Adaptive Modulation	1
ARQ	1
Dual Polarity Antenna	1
Range vs. Throughput	2
System Contents	3
Location of Serial Number & MAC Address	3
Location of RJ-45/LED Port & IP Reset Button	4
Chapter 2 Getting Started	5
Connections and Power	5
Configuration Tools	6
Changing Password	6
Troubleshooting Ethernet Connections	7
System Information (sysinfo) Page	7
Chapter 3 Configuration	10
Key Concepts	10
Essentials to Establish a Wireless Link	11
Master Unit Configuration	11
Remote Unit Configuration	12
Establishing a Wireless Link	12
Changing IP Address	12
LEDs	13
RF Link Loopback Test (linktest command)	14
Link Speed & Power Settings	14
Command Reference Listing	15
Chapter 4 Deployment & Installation	19
Site Selection	19
Site survey	19
Channel Planning	19
RSSI Command and Antenna Alignment	20
Mounting Hardware	22
Cabling and Weather Considerations	23
Weatherizing	23
Chapter 5 SNMP	24
Chapter 6 Firmware Upgrade Procedure	25
Firmware File Names	25
Firmware Upgrade Password	25
Upgrade Procedure	25
Example 1 Upgrade main image firmware to 1.0a6	25
Example 2 Upgrade web firmware to 1.0a6	26
Appendix A Using the HTTP Interface	27
Configuration Screen – Minimum Required Settings to Establish a Wireless Link	32
Appendix B Specifications	36

Preface

This manual covers the basic configuration and installation of the ATLAS5010 Wireless Point to Point Broadband System, and applies to the following radio part numbers:

P5010M-INT	Unit with internal patch antenna
P5010M-EXT	Unit with external antenna connectors

The ATLAS5010-INT consists of two P5010M-INT radios which have internal 23 dBi antennas. The ATLAS5010-EXT consists of two P5010M-EXT, and must be used in conjunction with an FCC certified external antenna (sold separately). Instead of an internal antenna, the P5010M-EXT has two Reverse Polarity SMA RF Connectors for the attachment of external antenna cables. The P5010M-EXT requires professional installation due to FCC limits on output power settings. See Page 21 for special instructions on setting U-NII output power limits when installing the P5010M-EXT

FCC Information

This device complies with Part 15 of the FCC Rules and Regulations. Operation is subject to the following two conditions: (1) This device may not cause harmful interference, and (2) this device must accept any interference received, including interference that may cause undesired operation.

This equipment has been tested and found to comply with the limits for a Class B digital device, pursuant to Part 15 of the FCC Rules. These limits are designed to provide reasonable protection against harmful interference in a residential installation. This equipment generates, uses, and can radiate radio-frequency energy and, if not installed and used in accordance with these instructions, may cause harmful interference to radio communications. However, there is no guarantee that interference will not occur in any particular installation. If this equipment does cause harmful interference to radio or television reception, which can be determined by turning the equipment off and on, the user is encouraged to correct the interference by one of more of the following measures:

- 1) Reorient the antenna.
- 2) Increase the separation between the affected equipment and the unit.
- 3) Connect the affected equipment to a power outlet on a different circuit from that which the receiver is connected to.
- 4) Consult the dealer and/or experienced radio/TV technician for help.

FCC ID: NCYP5010M

IMPORTANT NOTE:

Intentional or unintentional changes or modifications must not be made unless under the express consent of the party responsible for compliance. Any such modifications could void the user's authority to operate the equipment and will void the manufacturer's warranty. To comply with FCC RF exposure requirements, the following antenna installation and device operating configurations must be satisfied. The antenna for this unit must be fixed and mounted on outdoor permanent structures with a separation distance of at least two meters from all persons. Furthermore, it must not be co-located or operating in conjunction with any other antenna or transmitter.

Warranty Information

Radios from Trango Broadband Wireless are warranted for one year from date of purchase. Please see www.trangobroadband.com for a complete description of warranty coverage and limitations.

Contact Information

Corporate Headquarters	Trango Broadband Wireless, a division of Trango Systems, Inc. 15070 Avenue of Science Suite 200 San Diego, CA 92128 USA
Web Sites	www.tranobroadband.com www.trangosys.com
Sales Inquiries	email: sales@trangobroadband.com Telephone: 1-858-653-3900
Technical Support	email: techsupport@trangobroadband.com Telephone: 1-858-653-3900
Firmware Update Notices Mailing List	http://www.trangobroadband.com/maillinglist/maillingListAdd.aspx

Chapter 1 Overview

The ATLAS5010 is a point-to-point (PtP) wireless Ethernet transmission system which provides network connectivity at speeds up to 45 Mbps depending on the transmission distance and noise floor. The Atlas5010 utilizes OFDM technology and is designed for use in long range backhaul and wide area data networking applications.

Users are required to simply specify one P5010M (INT or EXT) unit type as master unit (MU) and one unit as remote unit (RU). Each unit utilizes Power-over-Ethernet (PoE) and is designed for outdoor environments. The cable entry point can accommodate both Shielded twisted pair Cat5 (STP) and unshielded twisted pair Cat5 (UTP), with the addition of conduit for tower mounting.

OFDM

The Atlas platform utilizes Orthogonal Frequency Division Duplex (OFDM) processing which offers link stability and performance in the presence of multipath interference.

Adaptive Modulation

One of the key advantages of the Atlas series radio platform is utilization of multiple modulation schemes including the following:

- Binary Phase Shift Keying (BPSK)
- Quadrature Phase Shift Keying (QPSK)
- 16 Quadrature Amplitude Modulation (16QAM)
- 64 Quadrature Amplitude Modulation (64QAM)

The Atlas system allows individual selection of the upstream and downstream modulation schemes. The modulation schemes can be adjusted manually or automatically (automatic rate shifting) for changing propagation and interference conditions. The higher order modulation schemes (64QAM) are typically deployed at reduced ranges while lower order modulation schemes (BPSK) are implemented at long distances.

ARQ

Another key advantage of the Atlas platform is its Automatic Repeat Request (ARQ) transmission correction scheme. The ARQ algorithm detects packet loss due to fading and interference conditions and requests the remote radio to re-transmit specific packets.

Dual Polarity Antenna

Atlas radios feature built-in dual polarity antenna functionality. Users may select either horizontal or vertical antenna polarity through the unit's software. Switchable antenna polarity provides greater spectral flexibility.

Range vs. Throughput

The following table shows approximate maximum ranges (at recommended fade margins) achievable with the ATLAS5010 system using various antenna configurations. Longer ranges are achievable, but will result in lower fade margins. To estimate theoretical throughput and fade margin for any distance, download the link budget / fade margin calculator tool from www.trangobroadband.com.

ISM (5725 MHz to 5875 MHz) Range & Throughput

Antenna	6 miles	20 miles	30 miles
Integrated 23 dBi 15" Flat Panel	45 Mbps (10db fade margin)	11 Mbps (20db fade margin)	6 Mbps (19db fade margin)
External 27 dBi 2' Dish	45 Mbps (17db fade margin)	20 Mbps (19db fade margin)	16 Mbps (20db fade margin)
External 30 dBi 3' Dish	45 Mbps (23db fade margin)	31 Mbps (22db fade margin)	20 Mbps (22db fade margin)
External 34 dBi 4' Dish	45 Mbps (31db fade margin)	35 Mbps (20db fade margin)	30 Mbps (16db fade margin)
Line-of-sight range			

U-NII (5470 MHz to 5725 MHz & 5250 MHz to 5350 MHz) Range & Throughput

Antenna	6 miles	10 miles	15 miles
Integrated 23 dBi 15" Flat Panel	20 Mbps (10 db fade margin)	11Mbps (12db fade margin)	6Mbps (9db fade margin)
External 27 dBi 2' Dish	31 Mbps (11db fade margin)	20 Mbps (10db fade margin)	11Mbps (12db fade margin)
External 30 dBi 3' Dish	31 Mbps (14db fade margin)	20 Mbps (13db fade margin)	16Mbps (12db fade margin)
External 34 dBi 4' Dish	45 Mbps (10db fade margin)	30 Mbps (13db fade margin)	20Mbps (14db fade margin)
Line-of-sight range			

System Contents

The Atlas5010 system is available in two versions:

- Atlas5010-INT - Radios with integrated 23 dBi antennas (part numbers P5010-INT)
- Atlas5010-EXT - Connectorized radios (part numbers P5010-EXT)

Each ATLAS5010 kit consists of two radios, two power-over-Ethernet (PoE) injectors, two AC adapters, port covers, and mounting hardware. A dual-polarized integrated antenna is located behind the radome of the P5010M-INT.

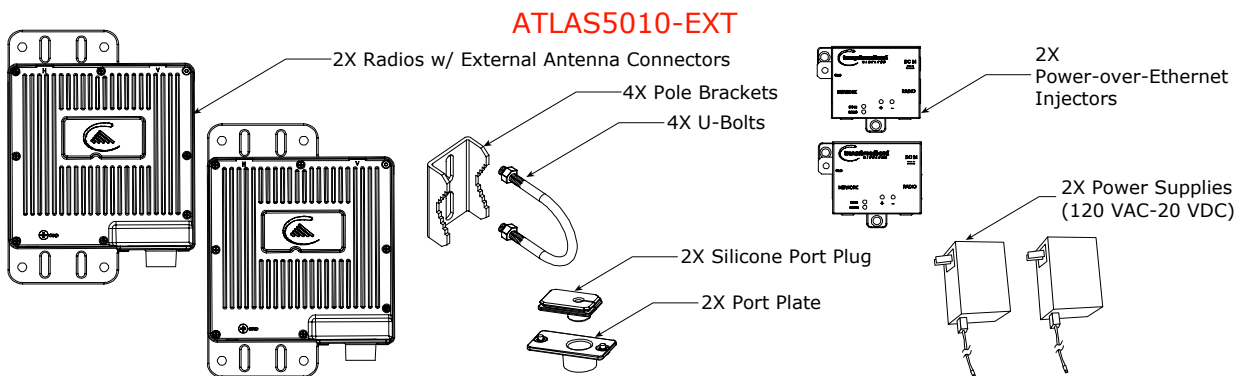
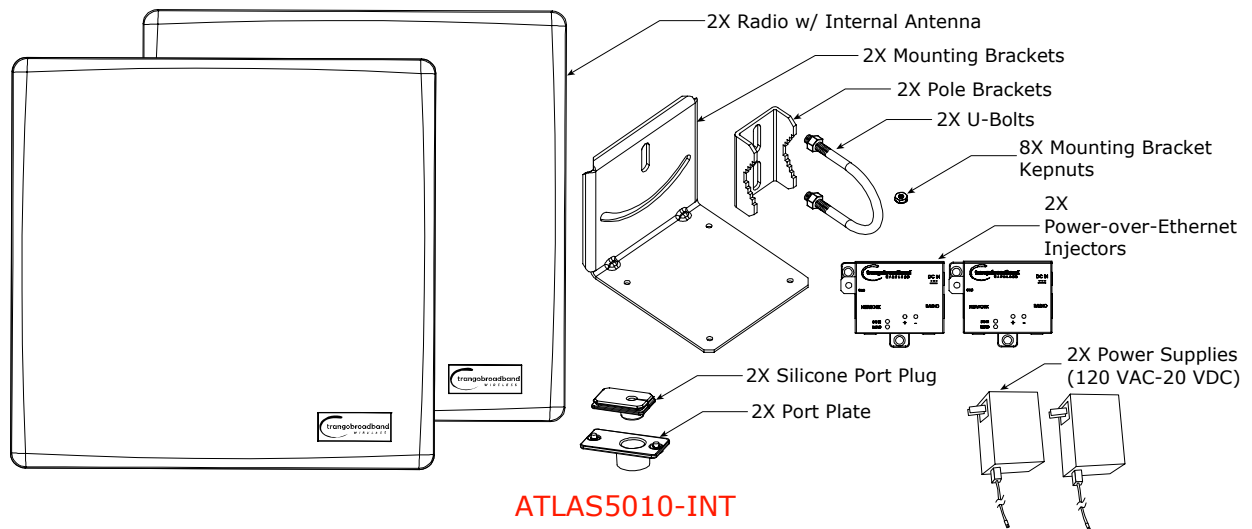

Location of Serial Number & MAC Address

The serial number and MAC address label can be found on the back of each radio. The serial number and MAC address is also provided within the system information (sysinfo) screen.

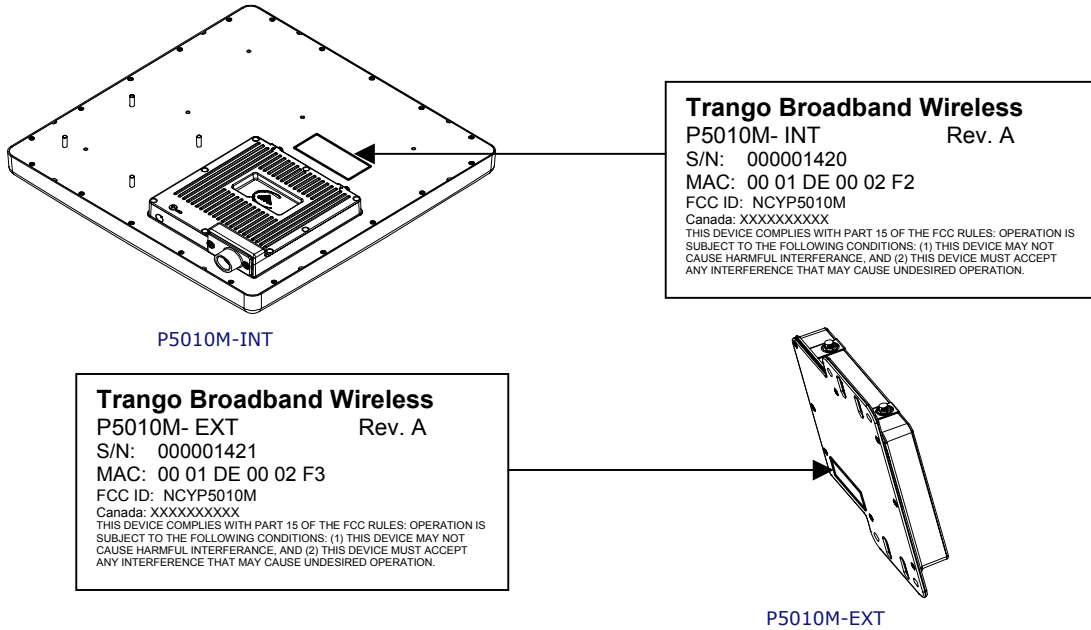

Location of RJ-45/LED Port & IP Reset Button

The RJ-45 connector, diagnostic LEDs, and reset button are located at the bottom of the radio. Functionality of the LEDs is described later in this text. The IP reset button resets IP configuration and password back to factory default. The reset button does not reset any other parameters other than IP configuration and password. Typically a user would only press the reset button when the IP configuration or password is unknown. Reset button must be held down for approximately 10 seconds.

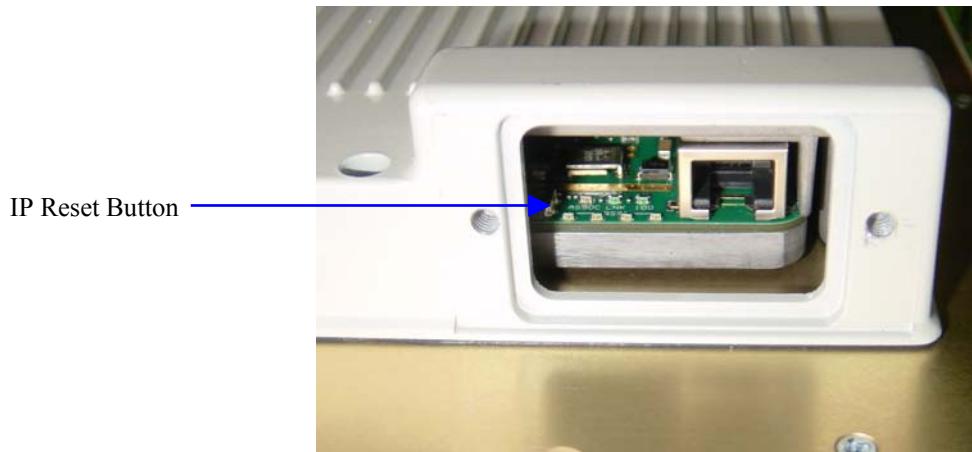

Chapter 2 Getting Started

It is always a good idea to first provision and test the radios on the bench before deploying them in the field. This is a particularly useful exercise for the novice user.

Connections and Power

- Connect a Cat-5 (straight through) Ethernet cable (we recommend shielded twisted pair) between the ODU (out door unit) port of the J-box and the RJ-45 connector on the radio. Note that this cable will carry power-over-Ethernet (PoE).
- If connecting to a COMPUTER, use a Cross-Over Ethernet cable from the NET port of the J-box to the computer's Ethernet port.

If connecting to a HUB, SWITCH, or ROUTER, use a Straight-Thru cable.

- Plug the AC adapter into an AC outlet.

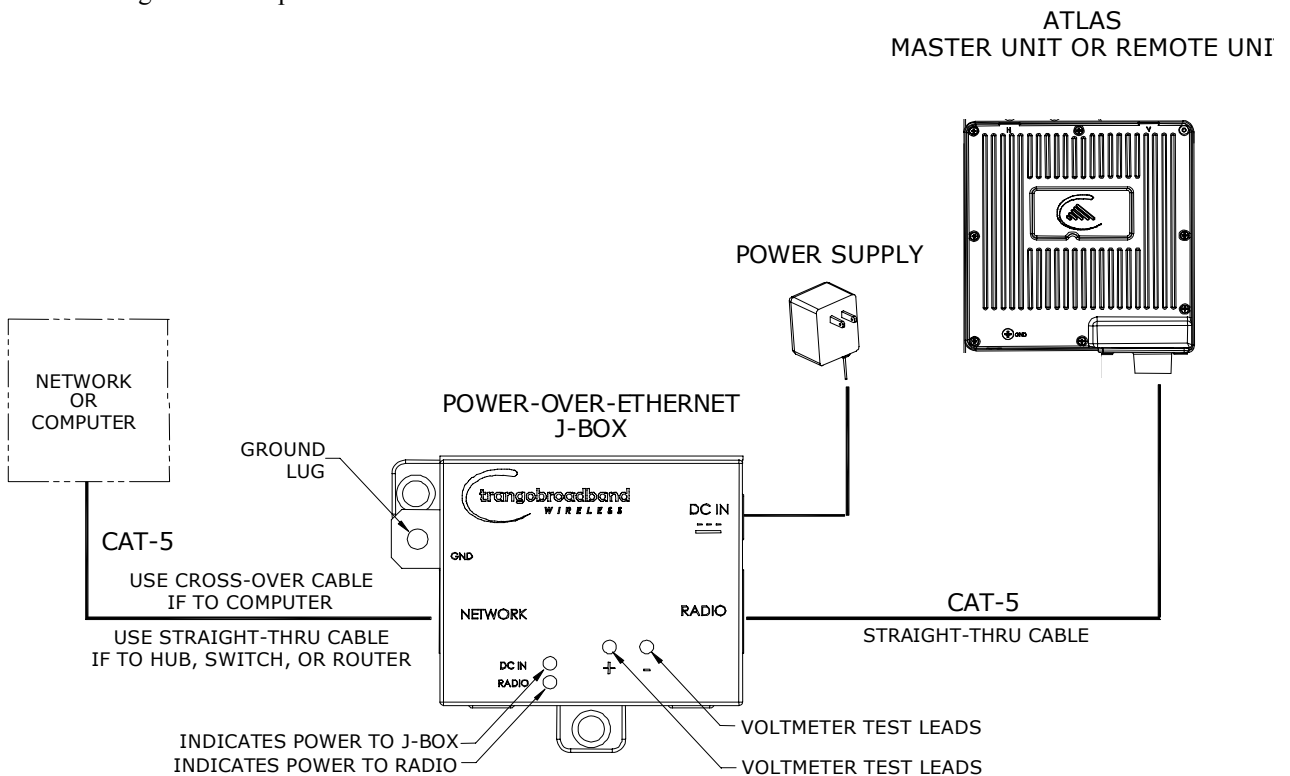

Both green LEDs on the J-box should be lit, indicating power is present at the Power-over-Ethernet box as well as at the radio.

You are now ready to configure the radio via the Ethernet port. After reboot, the Radio Power LED may take several seconds before lighting. The radio requires approximately 45 seconds to boot.

Configuration Tools

ATLAS5010 radios can be configured using either the Command Line Interface (CLI), or the Web Browser (HTTP) interface. Although both methods are comprehensive and powerful, the CLI method provides slightly more functionality.

This text covers configuration through the CLI. For HTTP configuration please see Appendix A.

Telnet

Open a command prompt (DOS) session on your PC. Open a Telnet session by typing:

telnet <ip address of radio>

Example:

```
C:>telnet 192.168.100.100
```

 Note: All Trango radios are pre-configured at the factory with a default IP address of 192.168.100.100.

You will be greeted with current hardware and firmware information and prompted for a password. Type in the password and press enter. The factory default read/write password is **trango**.

```
      Welcome to Trango Broadband Wireless, Atlas PtP-P5010M 1p0D05032202
      Password:
      Login as read/write.
#>
```

 Note: Type **help** for a listing of all CLI commands. Type **help [<command>]**, for the syntax of a particular command.

 Note: If you cannot access the radio management functions via the Ethernet port, check all cable connections and ensure that your PC is set up with a properly routable subnet.

Changing Password

Three types of passwords are used in the Atlas system:

rw	read write password. User can view and update all system parameters
ro	read only password. User can view system information only
Upgrade	Firmware upgrade password. This password must be included in the file name of the main image and web browser firmware files during the TFTP upload process.

Use the **password <ro|rw|upgrade>** command to change the various passwords.

Examples:

```
#> password rw
New Password (4 to 16 characters): *****
Confirm Password: *****
Success.
```

```
#> password ro
New Password (4 to 16 characters): *****
Confirm Password: *****
Success.
```

Troubleshooting Ethernet Connections

If you cannot telnet into the radio or open an HTTP browser session, check your cable connections to ensure proper use of cross-over vs. straight-through cable, and ensure your PC's subnet is routable to the radio's IP address.

System Information (sysinfo) Page

To display system configuration and status information type the command *sysinfo*.

The sysinfo screen is divided into 7 sections (0 –7)

Section	Description
0	Hardware/Firmware versions & system uptime (since reboot)
1	Mac, serial number, and IP configuration information
2	Opmode, RF info, speed, and peer connection status
3	RF channel table
4	Area code information denotes which channels and power limits are available based on region code of the radio. Area code is set by the factory and can not be altered by the user.
5	ARQ status, encryption, Auto-rate shift, remarks, and LED RSSI function
6	Ethernet TX/RX statistics.

Sysinfo Example:

```
#> sysinfo

***** 0 *****

[Model] P5010M
[Unit Type] RU
[Hardware Version] 5010
[Firmware Version] 1p0D05032202
[System Up Time] 0 day(s) 03:19:18

***** 1 *****

[MAC] 00 01 DE 1B 78 52
[S/N] 1800274
[IP] 10.254.1.2 [Subnet Mask] 255.255.255.248 [Gateway] 10.254.1.1

***** 2 *****

[Opmode] on [Default Opmode] on
[Active Channel] 2 h [Freq] 5280 MHz
[Speed] 36 Mbps [Tx Power] 7 dBm [Power Range] -4..7 dBm
[Peer ID] DE1B784B [Status] connected [RSSI] -75 dBm
[Peer IP Config] 10.254.1.3 255.255.255.248 10.254.1.1

***** 3 *****

Channel Table: (MHz, n/a: not available in current area)
[Ch#01] 5260 [Ch#02] 5280 [Ch#03] 5300 [Ch#04] 5320
[Ch#05] 5340 n/a [Ch#06] 5480 n/a [Ch#07] 5500 n/a [Ch#08] 5520 n/a
[Ch#09] 5540 n/a [Ch#10] 5560 n/a [Ch#11] 5580 n/a [Ch#12] 5600 n/a
[Ch#13] 5620 n/a [Ch#14] 5640 n/a [Ch#15] 5660 n/a [Ch#16] 5680 n/a
[Ch#17] 5700 n/a [Ch#18] 5720 n/a [Ch#19] 5735 [Ch#20] 5755
[Ch#21] 5775 [Ch#22] 5795 [Ch#23] 5815 [Ch#24] 5835

***** 4 *****

[Area Code] 0
RF Band #1 (5180..5240 MHz) Disabled
RF Band #2 (5260..5325 MHz) [Power Range] -4..7/7/7/7 dBm
RF Band #3 (5480..5720 MHz) Disabled
RF Band #4 (5735..5835 MHz) [Power Range] -4..21/19/18/17 dBm

***** 5 *****

[Tx MIR] 50000 Kbps
[ARQ] on
[Encrypt] off [Key] 0011 2233 4455 6677 8899 AABB CCDD EEFF
[Auto Rate Shift] on
[Auto Scan MU] off
[RSSI LED] on

[Remarks] atlas ru

***** 6 *****
```

```
[Eth In] 2,162,862 bytes 0 Kbps
[Eth Tx] 1,098,403 bytes 4 Kbps
[RF Rx] 471,841 bytes 0 Kbps
[RF Tx] 2,233,369 bytes 0 Kbps
```

```
Success.
#>
```

To view only a particular section of the sysinfo screen, type sysinfo followed by the desired section number.

Example:

```
#> sysinfo 2
```

```
***** 2 *****
```

```
[Opmode] on [Default Opmode] on
[Active Channel] 2 h [Freq] 5280 MHz
[Speed] 36 Mbps [Tx Power] 7 dBm [Power Range] -4..7 dBm
[Peer ID] DE1B784B [Status] connected [RSSI] -75 dBm
[Peer IP Config] 10.254.1.3 255.255.255.248 10.254.1.1
```

```
Success.
#>
```

Each of the parameters within the sysinfo screen is defined below

Section 0

[Model]	Radio Model # (P5010M)
[Unit Type]	User defined Unit Type (MU or RU)
[Hardware Version]	Hardware version set by factory (5010)
[Firmware Version]	Current firmware version loaded in radio
[System Up Time]	Time since last reboot or power cycle

Section 1

[MAC]	MAC address of radio
[S/N]	Serial Number of Radio
[IP]	User defined IP Address of radio
[Subnet Mask]	User entered IP Subnet Mask
[Gateway]	User entered IP address of the default router or gateway on the local Ethernet segment

Section 2

[Opmode]	Operation mode of the radio: ON = transmitting, OFF= not transmitting
[Default Opmode]	Opmode which the radio defaults to after reboot.
[Active Channel]	Active RF Channel and Antenna polarization
[Freq]	Frequency of active channel
[Speed]	Modulation Speed (6,12,18,24,36, 54 Mbps)
[Tx Power]	Transmit Power
[Power Range]	Allowable power range for chosen Frequency (dBm)
[Peer ID]	MAC Address of remote radio
[Status]	Connection status of remote radio (connected or disconnected)
[RSSI]	Measured signal strength from remote radio (dBm)

[Peer IP Config]

Remote radio's IP subnet, and default Gateway configuration

Section 3

Channel Table: (MHz, n/a: not available in current area)

[Ch#01] 5260 [Ch#02] 5280 [Ch#03] 5300 [Ch#04] 5320
 [Ch#05] 5340 n/a [Ch#06] 5480 n/a [Ch#07] 5500 n/a [Ch#08] 5520 n/a
 [Ch#09] 5540 n/a [Ch#10] 5560 n/a [Ch#11] 5580 n/a [Ch#12] 5600 n/a
 [Ch#13] 5620 n/a [Ch#14] 5640 n/a [Ch#15] 5660 n/a [Ch#16] 5680 n/a
 [Ch#17] 5700 n/a [Ch#18] 5720 n/a [Ch#19] 5735 [Ch#20] 5755
 [Ch#21] 5775 [Ch#22] 5795 [Ch#23] 5815 [Ch#24] 5835

Section 4

[Area Code]

Region (country code). Defines allowable frequencies. Area code is set by the manufacturer and can not be altered by the user.

RF Band #1 (5180..5240 MHz)

Disabled

RF Band #2 (5260..5325 MHz)

[Power Range] -4..7/7/7/7 dBm

RF Band #3 (5480..5720 MHz)

Disabled

RF Band #4 (5735..5835 MHz)

[Power Range] -4..21/19/18/17 dBm

Section 5

[Tx MIR]

Maximum Information Rate (Mbps). User may set Tx MIR in MU and RU to different values.

[ARQ]

Automatic Retransmit Request (On or Off)

[Encrypt]

Encryption (On or Off)

[Key]

Encryption Key (must match in MU and RU)

[Auto Rate Shift]

Automatic Rate Shift (adaptive modulation) (On or Off)

[Auto Scan MU]

Auto Scan MU (RU setting only). (On or Off)

[RSSI LED]

Enable or disable RSSI LEDs on bottom of radio. Disabling RSSI LEDs improves system performance.

[Remarks]

User entered remarks up to 256 characters. Field accepts alpha numerics only. Special characters (!@#%&*(?)\?) require quotations.

Section 6

[Eth In]

Counter for Ethernet packets which entered via the Ethernet port

[Eth Tx]

Counter for Ethernet packets which exited via the Ethernet port

[RF Rx]

Counter for Ethernet packets which entered via the wireless link

[RF Tx]

Counter for Ethernet packets which exited via the wireless link

Chapter 3 Configuration

Key Concepts

Prior to configuring the radios it is important to understand several key concepts:

Master Unit (MU) The MU is typically considered the primary radio within the link. For management purposes it is recommended to install the MU closest to the head-end of the network.

Remote Unit (RU)	The RU is typically installed at the remote end of the link. The primary distinction between the MU and RU is that when the radios are not associated, the MU will transmit and the RU will listen until the wireless link is established.
Peer ID	Authentication is controlled by the MAC address of each radio. The Peer ID is defined as the MAC address of the opposite radio. In other words, the Peer ID of the MU is the RU's MAC address and the Peer ID of the RU is the MU's MAC address.
Opmode	The radio has two modes of operation: 1) Opmode OFF – The radio is in a state which will not allow the establishment of a link with another radio. This state is mainly used for administration and pre-installation site survey 2) Opmode ON – The radio is in a state which allows it to establish a link to another radio if the proper settings are made. This is the normal “in service” state of the radio.
Default Opmode	Opmode (on or off) which the radio enters after reboot. Note: if you telnet into a radio within 30 seconds after reboot, the radio will remain in opmode OFF even if the default opmode is ON.

Essentials to Establish a Wireless Link

Configuration of the Atlas system is simple and at a minimum requires the following settings:

1. Designate one radio's unit type (utype) as the Master Unit (MU) and one unit as the Remote Unit (RU).
2. Program Peer ID in each radio.
3. Set MU and RU to same channel and antenna polarization
4. Set default Opmode to “ON” so that radio will automatically enter opmode after reboot.
5. Turn radios Opmode “ON”.

If all of these parameters are met, and if the MU and RU are within range and properly aligned, the wireless link will automatically establish itself and Ethernet traffic will begin to pass between the radios.

Master Unit Configuration

Start a telnet session with one of the radios. Follow these steps for configuration.

1. Set the Unit Type (utype) to MU in one radio. (default for all radios is RU)

```
#> utype mu
Success.
#>
```
2. Set the Peer ID with the MAC address of the RU. Only use the last 8 digits of the MAC address.

```
#> peerid de1B7850
Success.
#>
```
3. Set channel and polarization. (in this example set the channel to 23 and polarization to H).

```
#> freq 23 h
Ch# 2 h (5280 MHz)
Success.
```
4. Set default Opmode to ON.

```
#> defaultopmode on
Success.
```

5. Turn Opmode ON.

```
#> opmode on
Success.
```

Remote Unit Configuration

Configure the RU in the same manner as the MU. Since the default unit type (utype) is RU, you do not need to set this parameter.

1. Set the Peer ID with the MAC address of the MU. Only use the last 8 digits of the MAC address.

```
#> peerid de1B7842
Success.
#>
```
2. Set channel and polarization. (in this example set the channel to 23 and polarization to H).

```
#> freq 23 h
Ch# 2 h (5280 MHz)
Success.
```
3. Set default Opmode to “ON.”

```
#> defaultopmode on
Success.
```
4. Turn Opmode “ON.”

```
#> opmode on
Success.
```

Establishing a Wireless Link

If the MU and RU are properly configured and in opmode “ON”, the two radios will automatically begin the authentication process and become connected. To determine if the two radios are connected, type the **sysinfo 2** command.

Example:

```
#> sysinfo 2

***** 2 *****

[Opmode] on [Default Opmode] on
[Active Channel] 2 h [Freq] 5280 MHz
[Speed] 36 Mbps [Tx Power] 7 dBm [Power Range] -4..7 dBm
[Peer ID] DE1B784B [Status] connected [RSSI] -75 dBm
[Peer IP Config] 10.254.1.3 255.255.255.248 10.254.1.1

Success.
#>
```

The [status] field indicates whether the MU and RU are connected or disconnected. If connected, the MU and RU will automatically start passing Ethernet traffic over the wireless link.

Changing IP Address

Use the **ipconfig** command to change the radio’s ip address, subnet mask and gateway.

Syntax: *ipconfig* [*<ip>* *<subnet>* *<gateway>*]

Example:

```
#> ipconfig 10.8.2.140 255.255.255.240 10.8.2.129
New configuration: [ip] 10.8.2.140 [subnet mask] 255.255.255.240 [gateway]
10.8.2.129
```

```
save and activate ? (y/n) [ATTN] Telnet session will be terminated in 30
seconds.
Success.
#>
```

LEDs

LEDs are visible on the unit's PCB between the reset button and the RJ-45 connector. The function of each LED is described below:

LNK (green)

Green: On solid for an established 10BaseT or 100BaseT Ethernet Link.

SPEED

Green: Solid if 100BaseT, Blinks only if there is activity (TX or RX) on the network when a 100 MBit connection is established. Off if a 10BaseT connection is established or if there is 10BaseT activity.

RSSI (4 LEDs)

Amber: Four LEDs

In all modes except "Survey", the unit's four yellow LEDs indicate the level of RF signal being received from a VALID MU or RU as appropriate.

Yellow LED 1 : Begins blinking when RSSI is greater or equal to -90 dBm. On continuously at -85 dBm. This is the Leftmost LED

Yellow LED 2 : Begins blinking when RSSI is greater or equal to -80 dBm. On continuously at -75 dBm.

Yellow LED 3 : Begins blinking when RSSI is greater or equal to -70 dBm. On continuously at -65 dBm.

Yellow LED 4 : Begins blinking when RSSI is greater or equal to -60 dBm. On continuously at -55 dBm. This is the rightmost LED.

If no VALID MU or RU signal is detected the LEDs will not be on at all.

In addition, these 4 LEDs shall flash ON for 2 seconds, then OFF for 2 seconds to indicate the 'factory reset' button has been activated and the reset successful.

ASSOCiation LED (green):

The ASSOC led blinks at the following rates:

- Once every second when unit is powered on but opmode is OFF.
- Twice per second while in opmode ON and scanning for an MU or RU.
- Solid after unit is associated with the RU or MU.

RF Link Loopback Test (*linktest* command)

The *linktest* command is the primary tool to assess the quality of the link when *opmode* is on. The *linktest* command tests the throughput and packet error rate (PER) on the current channel for each direction at all speeds and reports results. This command also provides RSSI for both ends of the wireless link. The command can be run from either the MU or the RU. The *linktest* uses FEC but does NOT use ARQ, so all errors on the link are reported. Throughput numbers represent the absolute maximum bi-directional capacity including the management header (which is not available for user payload) so actual user throughput measurements will be slightly less.

In running the *linktest* command the user must specify the modulation speed for each end of the link.

Command format: **linktest <loc speed> <peer speed>**

Valid modulation speeds are: 6,12,18,24,36,48, and 54 Mbps. Lower speeds will result in fewer dropped packets.

Example:

```
# linktest 24 24
local tx rate = 24 Mbps
peer tx rate = 24 Mbps
packet size = 1600 bytes
# of packets per period = 1000
# of Cycle = 10
0> [tx] 1000 [rx] 1000 [rssi] -37 peer: [tx] 1000 [rx] 1000 [rssi] -40 -> 22.01 Mbps
1> [tx] 1000 [rx] 1000 [rssi] -37 peer: [tx] 1000 [rx] 1000 [rssi] -40 -> 22.01 Mbps
2> [tx] 1000 [rx] 1000 [rssi] -37 peer: [tx] 1000 [rx] 1000 [rssi] -40 -> 22.01 Mbps
3> [tx] 1000 [rx] 1000 [rssi] -37 peer: [tx] 1000 [rx] 1000 [rssi] -40 -> 22.01 Mbps
4> [tx] 1000 [rx] 1000 [rssi] -37 peer: [tx] 1000 [rx] 1000 [rssi] -40 -> 22.01 Mbps
5> [tx] 1000 [rx] 1000 [rssi] -37 peer: [tx] 1000 [rx] 1000 [rssi] -40 -> 22.01 Mbps
6> [tx] 1000 [rx] 1000 [rssi] -37 peer: [tx] 1000 [rx] 1000 [rssi] -40 -> 22.01 Mbps
7> [tx] 1000 [rx] 1000 [rssi] -37 peer: [tx] 1000 [rx] 1000 [rssi] -40 -> 22.00 Mbps
8> [tx] 1000 [rx] 1000 [rssi] -36 peer: [tx] 1000 [rx] 1000 [rssi] -40 -> 22.01 Mbps
9> [tx] 1000 [rx] 1000 [rssi] -37 peer: [tx] 1000 [rx] 1000 [rssi] -40 -> 22.01 Mbps

--> [tx] 10000 [rx] 10000 [rssi] -36 peer: [tx] 10000 [rx] 10000 [rssi] -40
--> [Local PER] 0.00 % [Peer PER] 0.00 %

Success.
#>
```

In this example the *linktest* was run at 24 Mbps at each end of the link. The results indicated 10 cycles of 1000 packets were transmitted and received from each end of the link without error. Actual achievable throughput is measured at 22 Mbps.

Link Speed & Power Settings

Users may change the radio’s over-the-air data rate and conducted output power using the *speed* and *power* commands. Keep in mind that the lower data rates offer higher receiver sensitivity and higher allowable conducted RF power in the ISM band. The following table shows the relation between speed settings, modulation scheme, receiver sensitivity, and allowable maximum power settings for each band. The lowest power setting for all bands in -4 dBm.

Also note that the power setting used in the radio may differ slightly from the FCC tested power output since the FCC measurement technique is slightly different than the technique used in the factory. For link budget purposes, use the numbers provided by Trango.

Speed Setting (over-the-air rate) (Mbps)	Modulation Scheme	Receiver Sensitivity (dB)	Max Power High (ISM) Band (dBm)	Max Power Low (U-NII) (dBm)
6	BPSK	-92	21	7

12	QPSK	-87	19	7
18	QPSK	-85	19	7
24	16QAM	-84	18	7
36	16QAM	-80	18	7
48	64QAM	-75	17	7
54	64QAM	-73	17	7

In this example the user sets the power to 19dBm and the speed to 24 Mbps:

```
#> power 19
Execution in progress...
.
19 dBm (-4..19)
Success.
#> speed 24
24 Mbps
Success.
#>
```

MU Autoscan Feature Description

This feature allows the RU to actively search all channels and polarizations for its peer MU in the event of a disassociation. This feature is useful if the user frequently changes the channel/polarization of the MU . If enabled, the *autoscanmu* routine in the RU performs a search for the peer MU by actively scanning all available channels and polarizations.

Notes regarding the autoscanmu feature:

- The RU will not activate the autoscan process after first 60 seconds of turning on opmode.
- The RU will start the auto scan process If RU loses association for more than 10 seconds,.
- The whole process will scan all available frequencies and polarizations in channel tables. The radio will spend 10 to 12 seconds for each frequency.
- For each frequency, radio will survey both polarizations, H and V. It will record the following information:
 - association
 - average RSSI of receiving P5010M packets
- After scanning all available frequencies in channel plan, the radio will select the channel based on the strongest average RSSI for receiving packets.
- If no channel is selected after completing the cycle, the process will start again.

Automatic Rate Shifting Feature Description

With autorateshift feature enabled, the radios will automatically renegotiate the modulation method and speed to maximize wireless link integrity. The link speed will vary depending on two factors: 1) the number of ARQ errors received, 2)successful processing of special link assessment packets sent in both the current and next higher speed. The radio will shift to the next higher in speed when no errors are detected. The radio will shift down in speed if error rate is excessive.

Notes regarding the autorateshift feature:

1. The radio will begin initial speed test when upon association to peer radio. There are 40 steps and around 50 seconds to complete this initial test. The radio will send link assessment packets (3600 byte packets at a rate of 100 packets per second) at the highest speed (54 Mbps). The radio will deliver payload at the speed which is specified before association. If the assessment packet dropping rate is higher than 10 percent, the speed test will decrease the speed for assessment packets. If the current payload speed is higher than the speed of assessment

packet, the radio will set the current payload speed to be the same as the assessment packet's speed. If the current payload speed is lower than the assessment packet's speed and more than 500 assessment packets have been transmitted, the radio will set the payload speed to be the same as assessment packet's speed.

2. After completion of initial speed test, the radio will set the payload speed to be the same as the final speed of initial speed test.

3. The radio will check link quality and adjust payload speed periodically.
 - a. The radio will increase payload speed every 60 seconds, if
 - i. Speed test which is running at higher speed is successful. –and–
 - ii. Payload's ARQ retransmit rate is less than 10 percent.
 - b. Radio will decrease payload speed every 10 seconds, if
 - i. Speed test which is running at payload speed is failure. –and–
 - ii. Payload's ARQ retransmit rate is higher than 10 percent.

4. Payload speed can be changed manually when auto rate shift is on. But the speed setting will not be sustained.

Encryption Feature Description

The Atlas system offers 128 bit proprietary encryption which may be turned on or off by the user. The HEX encryption key must be set in both the MU and RU. Users can expect faster payload speeds with encryption turned off as compared to with encryption turned on.

MIR Feature Description

Maximum Information rate is configurable on both the MU and RU. The MIR function is performed on the transmit side only and is based on a one second timing interval. During each one second timing interval, the total bits transferred is compared to the MIR limit configured by the user. When the limit is exceeded, no more data is sent and the packets in the queue will be dropped. This function is useful for reserving more bandwidth in one direction than the other. If left wide open, the system will respond to bandwidth demand as needed, allowing the full bandwidth of the channel to be used by either direction.

Command Reference Listing

The complete command set reference is provided below. You can also view a complete listing of all CLI commands by typing *help*.

antenna [h v]	Set or display antenna setting. H=Horizontal polarity, V=vertical polarity.
arq [on off]	Enable or disable Auto Retransmit Request (ARQ). With ARQ enabled, the Atlas system will retransmit packets which are detected as missing or corrupted. Default setting=ON.
autorateshift [on off]	Enable or disable automatic rate shift feature. With autorateshift enabled, the radios will automatically renegotiate speed setting to maximize wireless link integrity. Default setting=OFF.
autoscanmu [on off]	Enable or disable auto scan MU (RU only). Default setting=OFF . When autoscanmu is turned on, the RU will automatically scan all channels and polarizations searching for its peer MU. Once the RU detects the MU it will stop

	scanning and lock onto the channel of the MU. The autoscan feature is useful in cases where the user changes the channel at the MU because the RU will automatically search for the new channel of the MU. Note: auto-scanning may take as long as 5 minutes.
defaultopmode [on off]	Set or display default opmode. Radio must be set to opmode ON to establish wireless link. Default setting=OFF
encrypt [on off]	Enable or disable proprietary 128 bit tx encryption. Default setting=OFF
encrypt key <key>	Change encryption key (128 bits) <key> = xxxx xxxx xxxx xxxx xxxx xxxx xxxx xxxx
exit	Exit telnet session
freq [<ch#> <antenna>]	Set or display channel and antenna selection
freq writechannel <ch#> <freq>...	Modify channel table, up to 6 channels at a time
freq writechannel default	Restore factory default channel table
help [<command>]	Display command usage and syntax
ipconfig [<ip> <subnet> <gateway>]	Change ip configuration <ip> = ip address <subnet> = subnet mask <gateway> = gateway ip address
linktest <local tx rate> <peer tx rate> [<pkt size> [<# of pkt> [<# of cycle>]]]	RF link loopback test This is the primary loopback test utility for evaluating over-the-air link quality. Provides link reliability information and dropped packet statistics. Standard linktest transmits 1600 byte packets, 1000 packets per second for 10 cycles. User can specify packet size, quantity of packets, number of cycles <tx rate> = 6,12,18,24,36,48,54 Mbps
mir [<kbps>]	Set or display tx maximum information rate (MIR). MU and RU can be set with different mir for asymmetric upload and download. <kbps> = 100..50000
opmode [on off]	Set or display operation mode (on or off)
password <ro rw upgrade>	Change password <ro> = for read-only <rw> = for read-write <upgrade> = for upgrading firmware
peerid [<peer device id>]	Set or display peer device id
power [<dBm>]	Set or display tx power <dBm> is limited by area (ref: "sysinfo 4")
reboot	Reboot unit
remarks	Enter user remarks up to 80 characters
reset	Restore all factory defaults except ipconfig and passwords.
rsi	Display RF relative signal strength indication

	(rssi) from peer radio
rssiled [on off]	Enable or disable rssi LED update
speed [<tx rate>]	Set or display tx rate <tx rate> = 1,2,6,9,11,12,18,24,36,48,54 Mbps
survey [<sec>]	Display noise floor for current channel <sec> = period 10..3600 default = 10
survey <sec> all	Display noise floor for all available channels
survey <sec> [<ch#> [..]]	Display noise floor for selected channels
sysinfo	Display all system information
sysinfo [[<part #> [<part #> [..]]]	Display system information and status <part #> = 0..6 part 0: up time and version information part 1: MAC address and IP configuration part 2: RF link status part 3: channel table part 4: region code and power limitations part 5: switch settings and remarks part 6: statistics
syslog	Display system log
tftpd [on off]	Enable or disable tftpd (used for firmware upgrades)
utype [mu ru]	Set or display unit type
uniimaxpower [<power level>]	Set the max power for frequencies from 5.25 to 5.725 GHz based on the Antenna being used such that the EIRP does not exceed +30 dBm

Chapter 4 Deployment & Installation

Once you are familiar with the basic operation of the radios you are ready for deployment in the field. The deployment process consists of the following steps:

- Site Selection
- Site survey at MU and RU sites
- MU installation
- RU installation and antenna alignment
- Link test

Site Selection

Proper site selection for your MU will help ensure a successful deployment. Site selection will depend on a wide variety of factors, but from the radio's performance standpoint, please consider the following:

- Path from MU to RU should provide unobstructed line-of-sight (LOS), thus it is advisable to place MU as high as possible on a tall building or tower.
- Ethernet cable limit is 100 meters from Ethernet device (router, switch) to radio.
- Radios should never be deployed without proper grounding.
- Consider nearby sources of interference that could degrade the performance of the radio. Mount radios as far from sources of interference as possible.

Site survey

The radios provide an on-board site survey tool which measure the average and peak noise levels on any given channel.

To use the survey tool, the radio must be in Opmode "OFF." The survey can be performed for any specified amount of time (in seconds), and for either the horizontal or vertical polarization.

Prior to performing the site survey, place the radio in the installation spot, and aim the radio in the desired direction.

After the specified period, the results of this command will provide you with a listing of each channel in the band, the average signal received, and the maximum signal received during the survey period.

Example:

```
#> survey
```

```
Press any key to stop.
```

```
noise floor (peak/avg dBm)  rssi by pkt (peak/avg dBm)
0> -97 / -98      n/a
1> -97 / -98      n/a
2> -97 / -98      n/a
3> -97 / -98      n/a
4> -97 / -98      n/a
5> -97 / -98      n/a
6> -97 / -98      n/a
7> -97 / -98      n/a
8> -97 / -98      n/a
```

```
Ch 1 h 5260 --> -97 / -98  n/a
```

```
Success.
```

Channel Planning

Based on the results of the site survey at each end of the link, choose a channel which offers the lowest noise floor. In order to reliably operate in the higher speed modes, clean spectrum is essential.

RSSI Command and Antenna Alignment

Once the site survey is completed, you are ready to install your radios. Typically it is best to install the MU first. To properly align the radios, use the built-in RSSI tool to achieve maximum signal strength.

1. Ensure MU and RU are in Opmode “ON.”
2. Connect to the RU.
3. Login and type the command *rssi*. As you read the RSSI, move the antenna in the horizontal and vertical planes until the maximum RSSI reading is achieved
4. If it is not possible to receive an adequate RSSI reading, it may be necessary to reorient the MU (up/down, left/right), to increase the output power of the MU, or to move the RU to a location with better line-of-sight conditions to the MU.
5. Once you are satisfied with the RSSI reading, tighten down the RU in the optimum position.

Example:

```
#> rssi
Press any key to stop.
0> MU -75 dB      RU -75 dB      Connected
1> MU -75 dB      RU -75 dB      Connected
2> MU -73 dB      RU -73 dB      Connected
3> MU -72 dB      RU -71 dB      Connected
4> MU -70 dB      RU -70 dB      Connected
5> MU -70 dB      RU -69 dB      Connected
6> MU -69 dB      RU -70 dB      Connected
7> MU -70 dB      RU -70 dB      Connected
8> MU -70 dB      RU -70 dB      Connected
9> MU -67 dB      RU -68 dB      Connected
10> MU -67 dB     RU -67 dB      Connected
```

Success.

Users can also view the RSSI LEDs on the bottom of the radio. See the configuration section of this manual for more information.

Setting the Maximum RF Power for Legal Operation in the U-NII Band

Due to FCC restrictions the professional installer must manually set the maximum power for the 5.25 to 5.35 GHz U-NII band based upon which antenna is being used.

In all cases, Antenna Gain + Radio Max Power Setting can not exceed 30 dBm. As an example, if the radio is being installed with a 34 dBi antenna, then the radio max U-NII power must be fixed to -4 dBm. The antenna feed cable loss should be considered as well, leading to the following equation: $\text{Unimaxpower} = 30 \text{ dBm (max EIRP)} - \text{Antenna gain} + \text{cable loss}$. The power may be set in 1 dB increments within the range of -4 to +7 as shown in the following chart:

Antenna Gain	Maximum Allowed U-NII Tx Power
23	+7 dBm
30	0 dBm
34	-4 dBm

The Max Power Setting command is only accessible from the command line and is not available on the HTTP Browser interface.

The telnet command to change the maximum power is:

uniimaxpower <max power in dBm>

The command must be run on each P5010-EXT prior to installing the antenna and while the Opmode is OFF.

Example: To set the max power setting for the 34 dBi dish antenna with 2 dB of cable loss use the following command:

```
#> Uniimaxpower -2
```

The power is -2 based on the following: Uniimaxpower = 30 dBm (max EIRP) -34 dB (ant gain) +2 dB (cable loss)

Port Plug and Port Plate

Prior to deployment, insert the silicone port plug around the Cat-5 Cable and insert into the radio's port opening. Next, screw the port plate over the silicone plug as shown in the photographs below.

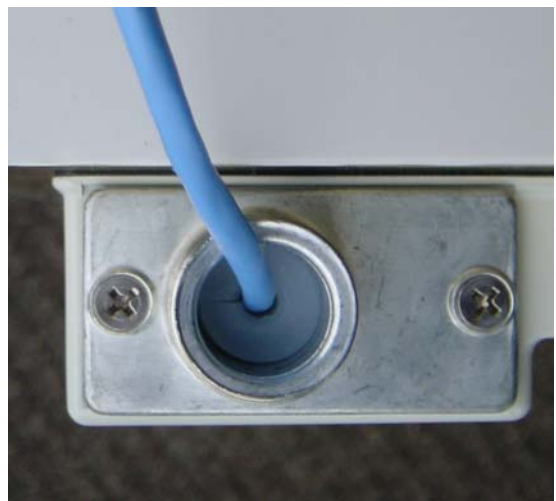

Mounting Hardware

Radios are supplied with mounting hardware for pole installations. See diagram below for proper use of the mounting hardware.

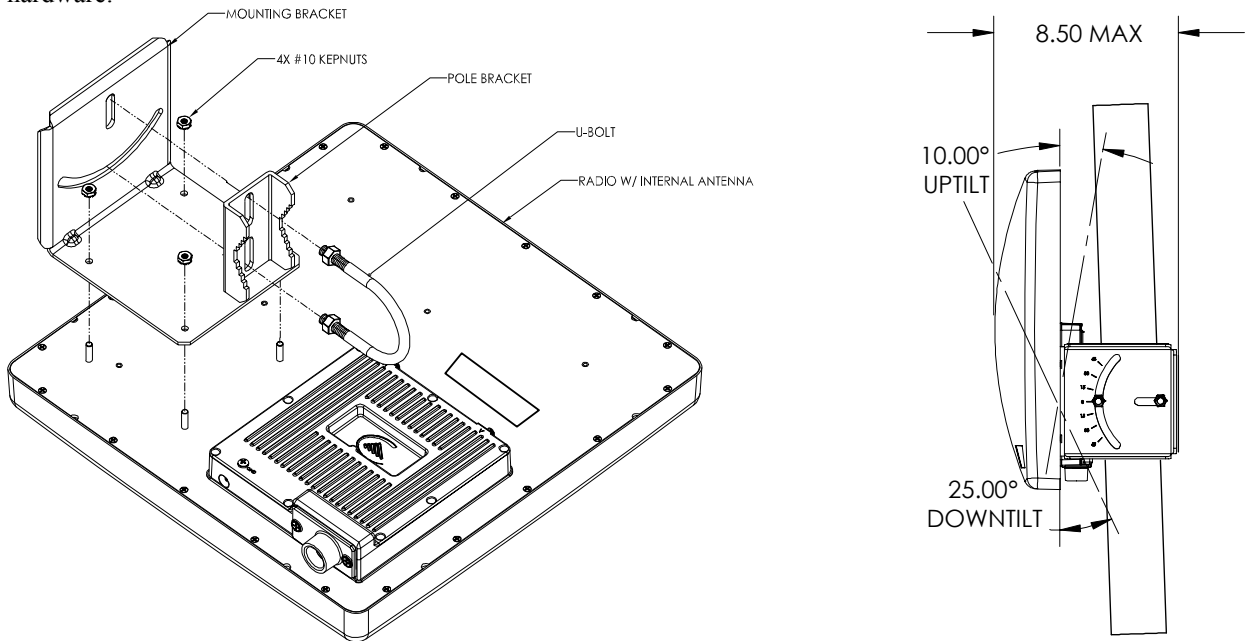

Mounting Hardware Assembly for Integrated Antenna P5010-INT

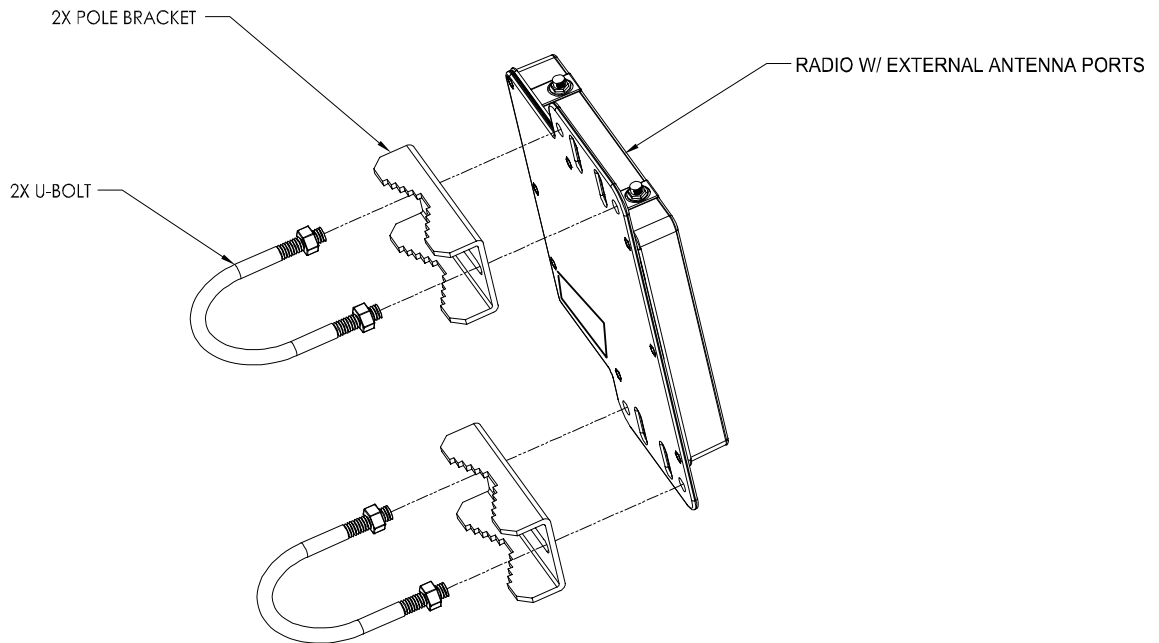

Mounting Hardware Assembly for P5010M-EXT

Connecting External Antenna on EXT Model

The P5010-EXT is equipped with two reverse-polarity SMA connectors on the top for attachment to an external antenna. Each SMA connector is labeled with either “V” for Vertical or “H” for Horizontal polarization. Connect each cable to the appropriate “H” and “V” ports on both the antenna and the radio.

NOTE: DO NOT USE MORE THAN 8 lb-Inch OF TORQUE OR THE CONNECTOR MAY BE PERMANENTLY DAMAGED.

It is important to properly seal each antenna connection to protect against moisture and corrosion. Each Atlas radio is shipped with a packet of Coax-Seal® connector sealant which should be applied over each of the SMA connectors. Coax-Seal is a gum-like tape which is applied by wrapping around the connector and then compressed/molded to form a single cohesive protective covering over the connector

To properly apply the Coax-Seal product first wrap the connector as shown:

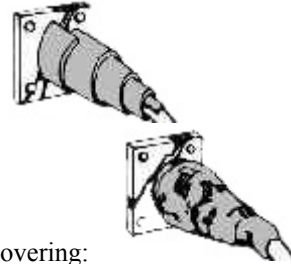

Secondly, compress the Coax-Seal product to mold into a single protective covering:

Grounding

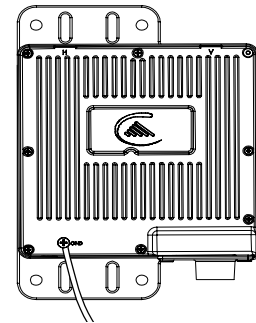

Proper mounting of the radio includes consideration for grounding. Please note that if the radio is attached to a metal pole that is earth-grounded, no other grounding is necessary. If the radio is not earth-grounded via the mounting bracket, you must attach a grounding wire to the grounding stud on the radio as in the adjacent diagram.



Cat-5 Cabling Considerations

Shielded twisted pair Cat-5 cable is recommended for all installations. The shield within the Cat-5 cable does not need to be grounded if the radio itself is grounded. It is important to consider that most Cat-5 cable will deteriorate over time if exposed to the weather (especially direct sunlight). It is recommended that installers place all Cat-5 cables inside conduit. Plastic conduit is sufficient. If metal conduit is used, it is not necessary to use shielded Cat-5 cable.

Weatherizing

-  **Important! Please note that the silicon strain relief has a small gap when the cable is installed. This is normal .**
-  **It is important to provide strain relief and drip loop for STP Cat-5 cables. Do not mount the radio upside down as water will enter the bottom of the radio and cause permanent damage**
-  **Important! The Power-over-Ethernet injector is not a weatherized device and must be located either indoors or in a weather-protected cabinet.**

Chapter 5 SNMP

The Atlas supports SNMP (Simple Network Management Protocol). Network management consists of the following 3 categories: configuration, Link and Association monitoring and Alarms. Besides this proprietary Management Information Base (MIB) the Atlas also supports a large part of the MIB-II OIDs.

Review the Trango MIB (TRANGO-P5M-MIB.mib) available on our website for the complete listing of all MIB objects available.

These capabilities allow the system administrator to provide superior service through higher network accessibility and integrated performance monitoring.

Depending on your Network Node Manager (NNM) it may be necessary to append a “.0” onto the end of each of the OIDs listed below for proper operation.

Objects for Configuration	Name	Description
1.3.6.1.4.1.5454.1.40.1.1.1	verUnitType	Returns radios unit type (0 = RU, 1= MU)
1.3.6.1.4.1.5454.1.40.1.8.3	sysswAutoScanMUSignal	Returns value of Auto Scan switch (0 = off,1 = on)
1.3.6.1.4.1.5454.1.40.1.3	sysDefaultOpmode	Returns defaultOpmode setting (0 = off,1 = on)
1.3.6.1.4.1.5454.1.40.1.4	sysCurrentOpmode	Returns current opmode setting (0 = off,1 = on)
1.3.6.1.4.1.5454.1.40.1.5	sysActivateOpmode	Turns opmode on
1.3.6.1.4.1.5454.1.40.1.13.1	sysipconfigIpAddress	Sets IP address
1.3.6.1.4.1.5454.1.40.1.13.2	sysipconfigSubnet	Sets subnet
1.3.6.1.4.1.5454.1.40.1.13.3	sysipconfigDefaultGateway	Set default gateway
1.3.6.1.4.1.5454.1.40.1.13.4	sysipconfigChange	Activates IP address change
1.3.6.1.4.1.5454.1.40.2.1	rfPeerDeviceID	Configure PeerID
1.3.6.1.4.1.5454.1.40.2.2	rfActiveChannel	Displays current channel
1.3.6.1.4.1.5454.1.40.2.3	rfActivePolarization	Displays current antenna polarization
1.3.6.1.4.1.5454.1.40.2.4	rfSpeed	Displays current Speed setting
1.3.6.1.4.1.5454.1.40.2.5	rfTxPower	Displays current transmit power (dBm)
1.3.6.1.4.1.5454.1.40.1.14	sysRemarks	Display radios remarks
Objects for Link and Association Monitoring		
1.3.6.1.4.1.5454.1.40.2.12	rfRSSI	Displays RSSI value (dBm)
1.3.6.1.4.1.5454.1.40.2.13	rfAssociated	Displays current association status (0 = disassociated,1 = associated)
1.3.6.1.4.1.5454.1.40.3.2	ruReboot	Reboots RU
1.3.6.1.4.1.5454.1.40.3.3	ruDistance	Displays current ru distance
Objects for Bandwidth Monitoring		
1.3.6.1.4.1.5454.1.40.1.9.1	systrafficeEthInOctets	Displays Ethernet in (bytes)
1.3.6.1.4.1.5454.1.40.1.9.2	systrafficeEthOutOctets	Displays Ethernet out (bytes)
1.3.6.1.4.1.5454.1.40.1.9.3	systrafficRfInOctets	Displays RF in (bytes)
1.3.6.1.4.1.5454.1.40.1.9.4	systrafficRfOutOctets	Displays RF out (bytes)
Objects for Alarm Monitoring		
1.3.6.1.4.1.5454.1.40.3.4.1.1	trapTrapDstEntry	
1.3.6.1.4.1.5454.1.40.3.4.1.2	trapTrapDstEnabling	Enable/Disable trap
1.3.6.1.4.1.5454.1.40.3.4.2	trapTrapIpAddress	Set destination trap IP
1.3.6.1.4.1.5454.1.40.3.4.3	trapTrapCommStr	Set trap community string

Chapter 6 Firmware Upgrade Procedure

Trango Broadband Wireless will from time to time release firmware upgrades for the Atlas series radios. The latest released firmware can be downloaded from <http://www.trangobroadband.com/support/downloads.htm>.

Firmware releases consists of two files: Main image firmware and Web (HTTP interface) firmware.

Firmware File Names

Firmware files are released in the format shown below. This example consists of main image and web firmware versions 1.0a6.

Main Image: p5m_1p0a6D05031505_Pupgrade
 Firmware Version: 1p0a6D05031505
 File Size: 1868288 bytes

Web web_1p0a6D05031505_Pupgrade
 File Size: 131584 bytes

Firmware Upgrade Password

The firmware filenames include the upgrade password (the characters after the ‘_P’ in the file name) The default upgrade password in the Atlas radios is *upgrade*. Users may change the upgrade password within the radios using the *password upgrade* command. Firmware release files from Trango Broadband Wireless will always be names with the default upgrade password of *upgrade*. If the user changes the upgrade password in the radio, then the firmware file name must be changed as well in order to upgrade the radios.

Upgrade Procedure

1. Place firmware files in easily accessible path in your computer.
2. In order to provide the most stable wireless conditions possible during the upgrade process it is recommended to set the radio speed to the minimum (6 Mbps) in both the MU and RU. Turn autorateshifting off during the upgrade.
3. Turn on the radio’s tftp daemon
4. From computer’s command prompt, tftp the firmware file into the radio using binary mode.
5. After file is successfully tftp’d to the radio, the radio will automatically reboot itself and load the new firmware

IMPORTANT: DO NOT POWER CYCLE OR INTERRUPT THE REBOOT PROCESS IN ANY MANNER. WAIT AT LEAST THREE MINUTES TO ENSURE AUTOMATIC REBOOT COMPLETION. LOSS OF POWER DURING THE REBOOT SEQUENCE WILL RESULT IN A CORRUPTED/INCOMPLETE FIRMWARE LOAD WHICH WILL REQUIRE REFLASHING AT THE FACTORY.

6. Repeat process for other radio
7. Repeat process for web file.

Example 1 Upgrade main image firmware to 1.0a6

FROM RADIO TELNET SESSION

```
Welcome to Trango Broadband Wireless, Atlas PtP-P5010M 1p0a4D05030303
Password:
Login as read/write.
```

```
#> tftpd on
Success.
#>
```

FROM COMPUTER COMMAND PROMPT SESSION

```
C:\Atlas>dir
Volume in drive C is Local Disk
Volume Serial Number is 7802-AAF7

Directory of C:\Atlas

03/16/2005  08:29a      <DIR>          .
03/16/2005  08:29a      <DIR>          ..
03/15/2005  04:34p             1,868,288  p5m_1p0a6D05031503_Pupgrade
03/15/2005  04:33p             131,584  web_1p0a6D05031505_Pupgrade
                2 File(s)          1,999,872 bytes
                2 Dir(s)   20,217,208,832 bytes free
```

```
C:\Atlas>tftp -i 10.254.1.2 put p5m_1p0a6d05031503_Pupgrade
Transfer successful: 1868288 bytes in 9 seconds, 207587 bytes/s
```

```
C:\Atlas>
```

NOTE: AT THIS POINT WAIT THREE MINUTES BEFORE PROCEEDING***Example 2 Upgrade web firmware to 1.0a6*****FROM RADIO TELNET SESSION**

```
Welcome to Trango Broadband Wireless, Atlas PtP-P5010M 1p0a6D05031505
Password:
Login as read/write.
#>
#> tftpd on
Success.
#>
```

FROM COMPUTER COMMAND PROMPT SESSION

```
C:\Atlas>tftp -i 10.254.1.2 put web_1p0a6d05031505_Pupgrade
Transfer successful: 131584 bytes in 1 second, 131584 bytes/s
```

```
C:\Atlas>
```

Appendix A Using the HTTP Interface

Open a browser session and type in the IP address of one of the radios. Default IP address is 192.168.100.100.

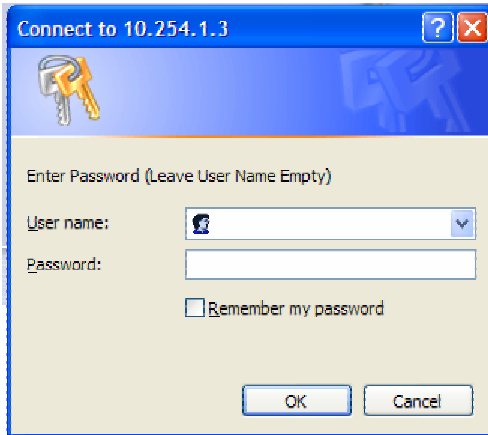

Leave the User name field blank and enter read write or read only Password. Press OK. Default password is trango. After logging on, the system information screen will be displayed.

Navigation links are shown on the left side of the browser screen. Navigable links include:

[System Information](#)
[Configuration](#)
[Site Survey](#)
[Link Control](#)
[Help](#)

The lower left portion of the screen shows the unit's current opmode, connection, channel, and antenna status.

The main body of the System Information displays most of the key parameters. To alter these parameters use the [Configuration](#) page.

To log off of the web browser interface, close the browser and the HTTP session will be automatically terminated.

Description of System Information entries. To view this information within the radio, click the [Help](#) link.

Model:	Model number.
Unit Type:	Atlas unit type either MU (master) or RU (remote).
Hardware Version:	Hardware version is factory-set and can not be changed by user.
Firmware Version:	Current firmware version loaded in the radio.
System Up Time:	Time since radio was last rebooted or powered.
MAC:	MAC address of the radio.
IP, Subnet Mask, Gateway:	IP, subnet mask, and gateway of radio
Opmode:	Current operation of the radio. \"On\" indicates transmitting. \"Off\" indicates not transmitting.
Default Opmode:	Opmode which radio enters after reboot or power cycle.
Peer ID:	User entered MAC address of the peer unit. In the MU, Peer ID is the MAC address of the RU. In the RU, Peer ID is the MAC address of the MU.
Status:	Status of Remote Unit. Connected (wireless link established) or disconnected (wireless link not established).
RSSI:	Relative Signal Strength Indicator. Displays signal strength received from the Remote Unit. 'n/a' indicates Remote Unit is not connected.
Tx MIR:	Transmit Maximum Information Rate to the peer unit.
Channel:	RF Channel
Tx Power:	Transmit power
Channel Table:	Set of channels based on the area code setting. Channels which are lined-out are not available for use based on area code setting.
Area Code:	Country code – defines set of available channels and maximum power based on regulatory restrictions. Setting can not be changed by user.
Auto Rate Shift:	See definition in Configuration section
Auto Scan MU:	See definition in Configuration section.
RSSI LED:	See definition in Configuration section.
Remarks:	See definition in Configuration section.
Eth In:	Counter for Ethernet packets which entered via the Ethernet port of the radio.
Eth Out:	Counter for Ethernet packets which exited via the Ethernet port of the radio.
RF In:	Counter for Ethernet packets which entered over-the-air into the radio.

RF Out:	Counter for Ethernet packets which exited over-the-air out the radio.
Configuration Page	
IP Address:	The IP address of this radio; used to manage the radio's application layer.
Subnet Mask:	The subnet mask of the radio.
Gateway:	The default gateway of the radio.
Default Opmode:	Operation mode of the radio after power cycle. When Opmode is \"On\" the radio will attempt to make a wireless connection. When Opmode is \"Off\" the radio is not transmitting, but can be managed from the wired side. In addition to setting Default Opmode to \"Off\", Opmode can be set to \"Off\" by interrupting the radios boot-up cycle in the first 30 seconds after power up
Peer ID:	User entered MAC address of the partner unit.
Switch:	Checked means active
Auto Rate Shifting	When enabled, radio will automatically shift TX rate up or down depending on link quality.
Autoscan MU	(RU Only). If this switch is enabled, when not connected to MU, the RU will automatically scan all available channels and frequencies
RSSI LED	Enables and disables RSSI LEDs. Disabling the LEDs provides slight improvement to radio performance. Typically RSSI LEDs should be enabled during alignment and disabled during normal operation.
Active Channel/Polarization:	The current channel and polarization of the radio when Opmode is \"On\".
Speed:	Transmit over-the-air raw data rate.
Power:	Transmit RF power setting.
Range:	Allowable range of the transmit power based on the current settings of the active channel and the speed.
Remarks:	A descriptive text field for general use (i.e. the location of the unit). It does not affect system performance.
MIR:	Set Maximum Information Rate for network traffic.
ARQ:	Auto Retransmit Request. When enabled, dropped packets are detected at the receiver and retransmitted by the transmitter.
Encrypt:	Encryption. Enables and disables proprietary 128 bit over-the-air encryption.
Key:	128 Encryption Key. Must match in both MU and RU.
Activate Opmode On:	Activates radio's Opmode to "On"-transmitting.
Activate Opmode Off:	Activates radio's Opmode to "Off" not-transmitting.

Reboot: Reboot the unit.

Close All Telnet Sessions: Close all the active telnet sessions.

Configuration Screen

The screenshot displays the configuration interface for the Atlas P1P RU device. The browser window shows the URL `http://10.254.1.2/trango/hw/config.shtml`. The page is titled "Atlas P1P RU" and "Trango Broadband Wireless". The left sidebar provides navigation options: System Information, Installation, Configuration Site Survey, Management, Link Control, and Current Status. The main configuration area is titled "Configuration" and includes the following settings:

- Unit Type:** RU (selected)
- IP Address:** 10.254.1.2
- Subnet Mask:** 255.255.255.248
- Gateway:** 10.254.1.1
- Default Opmode:** On
- Peer ID:** DE1D764D
- Switch:**
 - Auto Rate Shifting Enable:
 - Auto Scan Master Unit Signal Enable (RU Only):
 - RSSI LED Flashing Enable:
- Active Channel:** Ch#2 5280
- Polarization:** V (selected)
- Speed:** 36 Mbps
- Power:** 7 dBm, Range: -4.7
- Remarks:** atlas.ru
- MIR:** 50000 Kbps
- ARQ:** On
- Encrypt:** Off
- Key:** 0011, 2233, 4455, 6677, 8899, AADB, CCDD, EEFF

At the bottom of the configuration area, there are buttons for "Save and Activate Settings", "Activate Opmode On", "Activate Opmode Off", "Reboot System", and "Close All Telnet Sessions". The footer of the page includes the Trango Broadband Wireless logo and contact information: "Trango Broadband Wireless, a division of Trango Systems, Inc.", "http://www.trangobroadband.com", and "mailto:techsupport@trangobroadband.com".

All user configurable parameters can be entered from the Configuration Screen and this is the only screen used to provision a wireless link between the two radios.

Configuration Screen – Minimum Required Settings to Establish a Wireless Link

To configure a wireless link, user must (at a minimum) enter the following information:

Unit Type:	Set one radio as the MU and one radio as the RU. Click on “Change Unit Type” to save the setting.
IP Configuration:	Each radio should be set up with a unique IP address to enable remote management. Click on “Change IP Config” to save the setting.
Default Opmode:	Should be “On”. Radio will enter default opmode approximately 30 seconds after complete reboot cycle. Opmode must be “On” for radios to transmit and wirelessly connect.
Peer ID:	Enter the last 8 digits of the peer units MAC address. Atlas radios will only wirelessly connect to the peer ID with the specified MAC address.
Active Channel:	Select a channel & antenna polarization. Both MU and RU should be set to the same channel unless RU’s “Auto Scan Master Unit Signal Enable” is enabled. If Auto Scan is enabled, the RU will automatically scan all channels and polarizations searching for it’s peer MU. Once the MU is detected, the RU will automatically set its active channel and antenna polarization to that of the MU.

Click “Save and Activate Settings” to save settings.

If all settings are entered correctly, and if radios are within operating range – the MU and RU will automatically wirelessly connect and Ethernet traffic will begin to pass across the wireless link.

To verify connection status, refer to the System Information page. Status of “connected” in section 2 of the system information screen will indicate that a wireless link is established between MU and RU. Connection status can also be viewed in the left-hand margin portion of all HTTP screens. Signal strength (RSSI) received from the peer radio is also provided on this screen.

Connection Status

Atlas PtP RU

System Information Trango Broadband Wireless

Model P5010M
 Unit Type RU
 Hardware Version 5010
 Firmware Version 1p0D05032202
 System Up Time 02:41:15

MAC 00 01 DE 1B 78 52
 IP 10.254.1.2 Subnet Mask 255.255.255.248 Gateway 10.254.1.1

Opmode on Default Opmode on
 Peer ID DE1B784B Status connected RSSI -74 dBm
 Channel 2 h Tx Power 7 dBm

Channel Table (MHz)
 Ch#01 5260 Ch#02 5280 Ch#03 5300 Ch#04 5320
 Ch#05 5340 Ch#06 5400 Ch#07 5500 Ch#08 5520
 Ch#09 5540 Ch#10 5560 Ch#11 5580 Ch#12 5600
 Ch#13 5620 Ch#14 5640 Ch#15 5660 Ch#16 5680
 Ch#17 5700 Ch#18 5720 Ch#19 5735 Ch#20 5755
 Ch#21 5775 Ch#22 5795 Ch#23 5815 Ch#24 5835

Area Code 0
 RF Band #1 (5180..5240 MHz) Disabled

Peer ID DE1B784B
 connected RSSI -74 dBm

Web Ver 1p0D05032202

Site Survey Page

The site survey function measures overall noise floor as well as in-band noise containing data packets. Noise is reported in terms of average and peak dBm for the period tested. The user specifies duration of the test in minutes as well as the antenna port. To run a site survey, the radio must be in Opmode OFF.

The screenshot shows the 'Atlas PTP RU' web interface. The left sidebar contains navigation links: System Information, Installation, Configuration, Site Survey, Management, Link Control, and Help. The 'Current Status' section shows Opmode: off, Channel: 2 h, Peer ID: DE1B784B, disconnected RSSI: n/a, and Web Ver: 1p0a6D05031401.

The main 'Site Survey' section includes a 'Start Survey' button and a 'Status' dropdown set to 'Finished'. Below this, there are controls for 'Polarization' (set to 'V') and 'Duration' (set to '1' min(s)).

The data table below shows noise floor and RSSI measurements for 24 channels:

Ch#	Freq	[Noise Floor]		[rsi-by-packet]		Clear
		Avg dBm	Peak dBm	Avg dBm	Peak dBm	
1	5260	-97	-98	n/a	n/a	
2	5280	-97	-90	-74	-74	
3	5300	-96	-98	n/a	n/a	
4	5320	-97	-98	n/a	n/a	
5	5325	-55	-90	n/a	n/a	
19	5735	-82	-95	n/a	n/a	
20	5755	-97	-98	n/a	n/a	
21	5775	-75	-84	n/a	n/a	
22	5795	-90	-91	n/a	n/a	
23	5815	-83	-85	n/a	n/a	
24	5835	1	undefined	undefined	undefined	

In this example the site survey function was performed for 1 minute on the vertical polarity. The lower band (5250 – 5340 MHz) is reported to be relatively clean with a noise floor in the range of –97 to –98 dBm. The noise floor in the upper band (5735 – 5835 MHz) is higher and ranges from –58 dBm (at 5735 MHz) to –90 dBm (at frequency 5775 MHz). In this example, channel 19 is the noisiest and should be avoided.

Link Control

The Link Control page features the RF Link Loopback / Speed Test. In this test, the user specifies the transmission rate (in Mbps) in both the local radio and the peer radio as well as the duration time (in minutes) for the test. During the test, the local radio will transmit packets across the wireless link. The peer radio will retransmit equivalent packets back to the local radio. The test will measure and report error rate and actual throughput as measured in Mbps. The following link test was run for 60 seconds with a specified TX rate of 12 Mbps per end.

To run a link loopback test, both radios must be in Opmode ON and status “Connected”

The screenshot shows the 'Link Control' page for 'Atlas PtP RU'. The interface includes a navigation menu on the left with options like System Information, Installation, Configuration, Site Survey, Management, Link Control, and Help. The main content area is titled 'Link Control' and features the 'RF Link Loopback / Speed Test' section. This section has a warning: 'Warning! Some traffic may be dropped during testing'. Below the warning, there are input fields for 'Local Tx Rate' and 'Peer Tx Rate', both set to '12 Mbps', and a 'Duration' field set to '1 min(s)'. A 'Loopback Test' button is present. The 'Test Results' section shows a table with the following data:

	Tx Rate	Tx Bytes	Error Rate
MU to RU	12	20800000	0.00
RU to MU	12	20800000	0.00

Below the table, it states 'Aggregated Bandwidth: 11.9 Mbps'. At the bottom of the page, there is contact information for 'Trango Broadband Wireless, a division of Trango Systems, Inc.', including a website URL and an email address.

In this example, the error rate was 2 packets from MU to RU and 0 packets from RU to MU. Measured aggregate bandwidth is 10.93 Mbps.

Appendix B Specifications

RF Parameters

Transmitter

RF Conducted Power: Band 2 (U-NII) Max: +7 dBm
Limits 5.26-5.32 GHz Min = -4 dBm

Band 4 (US ISM): Max: +21 dBm (6 Mbps)
5.725-5.85 GHz Max: +19 dBm (12, 18 Mbps)
Max: +18 dBm (24, 36 Mbps)
Max: +17 dBm (48, 54 Mbps)
Min: -4 dBm

EIRP Max: +45 dBm High band P5010M-23-MU/RU (23 dBi panel antenna)
+56 dBm High band P5010M-EXT-MU/RU w/34 dBi 4 foot dish antenna
+30 dBm Low band with all antennas

RF Data Rate: 6, 12, 18, 24, 36, 48, 54 MBPS User selectable
Error Correction: FEC & ARQ
Modulation: 6 MBPS DBPSK OFDM for header, 6-54 MBPS OFDM for payload

Receiver

Receiver Sensitivity Table

Max Speed (Mbps)	Sensitivity dBm
54 (45)	-73
48 (40)	-75
36 (31)	-80
24 (20)	-83
18 (16)	-86
12 (11)	-88
6 (5)	-92

Numbers in parentheses are actual max user throughput speeds

Channels of Operation

Storable Channels: 24 memory locations

Center frequency ranges:

Band 2: 5.260 to 5.325 GHz
Band 4: 5.735 to 5.835 GHz

Tuning resolution: 5 MHz increments

(US Models)

Channel 1: 5.260 GHz -Band 2
Channel 2: 5.280 GHz -Band 2
Channel 3: 5.300 GHz -Band 2
Channel 4: 5.320 GHz -Band 2
Channel 5: 5.325 GHz -Band 2

Channel 6: 5.480 GHz	-Band 3 (pending)
Channel 7: 5.500 GHz	-Band 3 (pending)
Channel 8: 5.520 GHz	-Band 3 (pending)
Channel 9: 5.540 GHz	-Band 3 (pending)
Channel 10: 5.560 GHz	-Band 3 (pending)
Channel 11: 5.580 GHz	-Band 3 (pending)
Channel 12: 5.600 GHz	-Band 3 (pending)
Channel 13: 5.620 GHz	-Band 3 (pending)
Channel 14: 5.640 GHz	-Band 3 (pending)
Channel 15: 5.660 GHz	-Band 3 (pending)
Channel 16: 5.680 GHz	-Band 3 (pending)
Channel 17: 5.700 GHz	-Band 3 (pending)
Channel 18: 5.720 GHz	-Band 3 (pending)
Channel 19: 5.735 GHz	-Band 4
Channel 20: 5.755 GHz	-Band 4
Channel 21: 5.775 GHz	-Band 4
Channel 22: 5.795 GHz	-Band 4
Channel 23: 5.815 GHz	-Band 4
Channel 24: 5.835 GHz	-Band 4

Data Parameters

Format: 10/100 BaseT IEEE 802.3 Ethernet compliant
 Ethernet packet: Up to 1518 byte packets

Regulatory Compliance

FCC Standards

FCC 15.109
 FCC 15.203 Antenna
 FCC 15.207
 FCC 15.209
 FCC 15.401 through 15.407(2) U-NII Band transmitter –
 FCC 15.247 ISM transmitter

Canada Standards

RSS-210
 RSS-102
 ICES-003

Mechanical

Material: Powdercoated Aluminum case/back with UV Stabilized ABS radome (P5010-INT)
 Size: 15" x15" for P5010M-INT
 5" X 5" for P5010M-EXT
 Weight: P5010M-INT: 7 lb
 P5010M-EXT: 4 lb
 Mounting: Custom pole/flat surface mounting with elevation adjustment.

Environmental

Operating Temp: -40 to 60 deg C
 Storage: -40 to 85 deg C
 Humidity: 100 % when sealed properly

NEMA Rating: NEMA 4
 Shock: Sustain 3 axis drop from 5 feet

Power Parameters

Input Voltage: Input voltage range at unit is 10.5 VDC to 24 VDC max. Power is supplied on Ethernet cable using junction box provided with up to 330 foot 24 AWG STP cable.

Current Cons.: Max 600 mA in transmit and receive modes using 24 V standard adapter (12 W) with short Ethernet cable from Junction box to radio.

Power Supply

Type: Switch mode wall mount transformer
 Safety: PSE, UL, CUL, GS
 EMI: FCC Class B, VCC-II, CE
 Input: 90 – 255 VAC
 Plug Type: Includes 4 plug blades for to allow use in US, Europe, UK and Australia
 Output: 24 VDC +/- 1 V
 Max current: 750 mA

Antennas:

Integrated Antenna (for Atlas5010-INT)

Frequency range: 5250-5850 MHz
 Gain: 23 dBi +/- 1 dB
 Front/Back Ratio >35 dB
 E-Plane Beamwidth: > 9 degrees typical
 H-Plane Beamwidth: > 9 degrees typical
 Polarization: Vertical and Horizontal
 Port/Port Isolation: 40 dB typ
 Cross Pol Rejection: 25 dB typ
 VSWR: <1.7:1
 Package: Aluminum backplate with plastic radome.
 Dimensions: 14.6”x 14.6”x 1.58” (371mm x 371mm x 40mm)
 Weight: 5.5 lbs (2.5 kg)
 Azimuth/El Adjust: +/-30 degrees
 Temp Range: -40 deg F to +160 deg F (-40 deg C to +60 deg C)
 Wind speed operational: 100 mph (160 km/hr)
 Wind speed survival : 140 mph (220 km/hr)

FCC Certified External Antennae (for Atlas5010-EXT)

Radiowaves models: SPD4-5.2, SPD3-5.2, SPD2-5.2, SPD1-5.2

See Radiowaves, Inc. for specifications and details .