

FALCON PLUS SERIES

5.8 GHz Wireless Video/Audio/Alarm/Data Transmission System

Installation and Operating Instructions



Quick Start Guide

- 1• Verify proper operation of camera and monitor/event recorder using coaxial cable prior to installing wireless link.
- 2• Install transmitter (VTX5900) and receiver (VRX5900) units in desired location to a steel pole per installation drawing. The pole *must be* securely mounted so that it does not move, and may be from 1.5" to 3" in diameter.
- 3• Install antennas above the enclosures.



WARNING

USE EXTREME CARE WHEN INSTALLING ANTENNAS NEAR POWER LINES.

- 4• Slide heatshrink over antenna cable. Tighten antenna cable to receiver and transmitter. Heat up the heatshrink until it contracts around the connector junction.
- 5• Connect video, audio, power, alarm, PC interface cables as needed to units through flanges. Tighten flanges to allow small air gap at bottom of enclosure.

IMPORTANT NOTE:

Power adapter must be kept dry.

- 6• Verify that LEDs are lit up and transmitter and receiver are on same channel.
- 7• Tighten lid of enclosure down.
- 8• To help protect against potential lightning damage, use a lightning surge arrester in line with all cabling entering a structure and at the antenna input.



CAUTION

DO NOT APPLY POWER TO THE TRANSMITTER UNLESS THE ANTENNA IS CONNECTED. PERMANENT DAMAGE MAY RESULT.

Your Trango Wireless Video System

Congratulations on choosing Trango Systems, Inc. to fulfill your wireless video needs. Unpack your system carefully. If any items are missing, notify your sales representative. If an item appears to be damaged from shipment, replace it in its packing material and notify the shipper.

Save the packaging for further storage of the equipment.

Service:

If the unit ever needs repair service, contact your Trango Systems, Inc. distributor for return authorization and shipping instructions.

FCC Information:

Note: This equipment has been tested and found to comply with the limits for a Class B digital device, pursuant to Part 15 of the FCC Rules. These limits are designed to provide reasonable protection against harmful interference in a residential installation. This equipment generates, uses, and can radiate radio frequency energy, and if not installed and used in accordance with these instructions, may cause harmful interference to radio communications. However, there is no guarantee that interference will not occur in a particular installation. If this equipment does cause harmful interference to radio or television reception, which can be determined by turning the equipment off and on, the user is encouraged to correct the interference by one of more of the following measures:

- 1) Reorient the receiving antenna;
- 2) Increase the separation between the affected equipment and the receiver;
- 3) Connect the affected equipment to an outlet on a different circuit from that which the receiver is connected to;
- 4) Consult the dealer and/or experienced radio/TV technician for help.

VTX2500: # NCYVTX5900

CANADA:

IMPORTANT NOTE:

Intentional or unintentional changes or modifications not expressly approved by the party responsible for compliance must not be made. Any such modifications could void the user's authority to operate the equipment and will void the manufacturer's warranty.

System Description:

The FALCON PLUS Wireless Video System is a professional quality system designed for sending composite NTSC or PAL video, audio, and alarm signals using 5.8 GHz wireless technology. The typical FALCON PLUS system consists of a VTX5900 transmitter and antenna, VRX5900 Receiver and antenna, and power adapters. The system is ideal for permanent or temporary video links due to its portable nature and easy installation. It is *not* designed for operation while in motion.

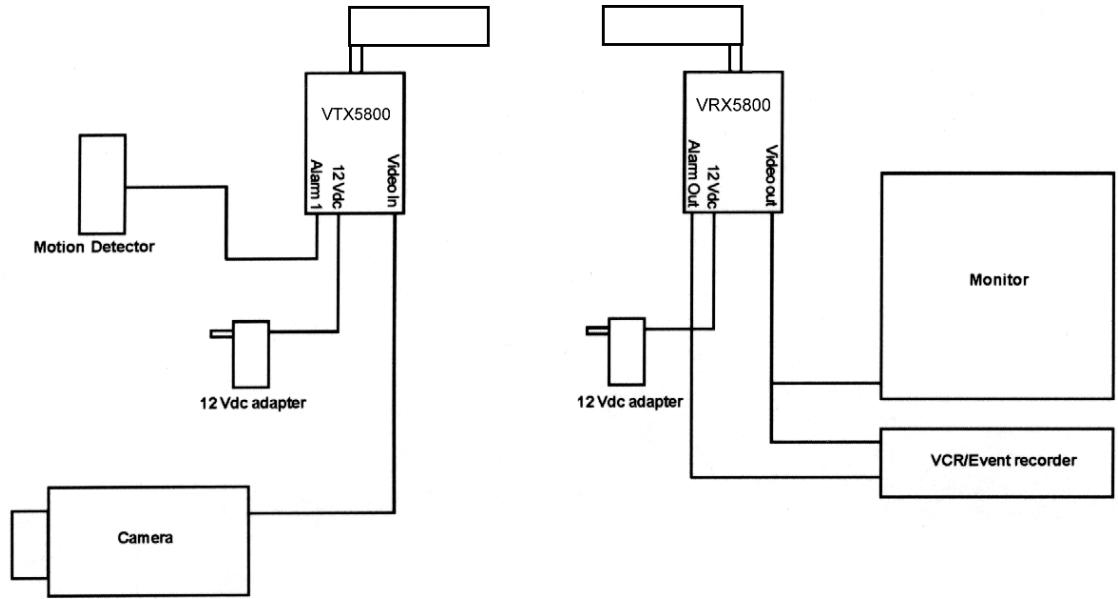

• FIGURE 1a •

Figure 1a shows the most common connection diagram for setting up a wireless video link using the FALCON PLUS. Audio and power connections are not shown.

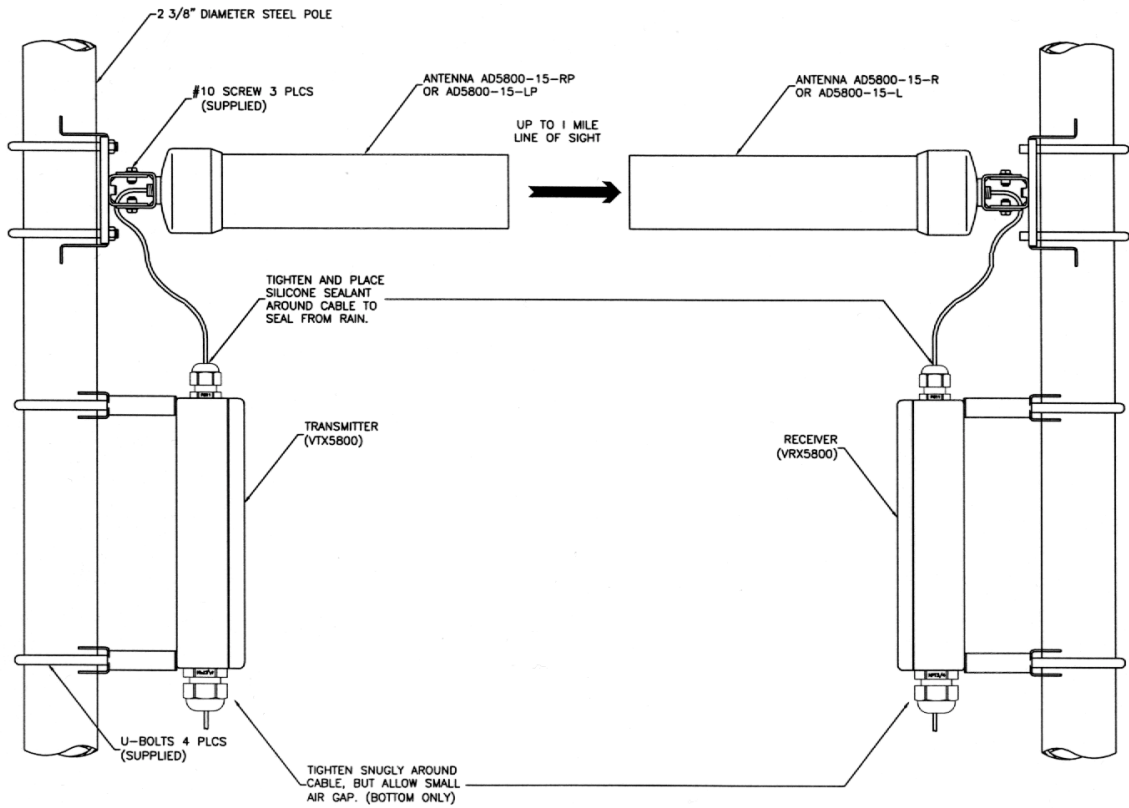

FIGURE 1b

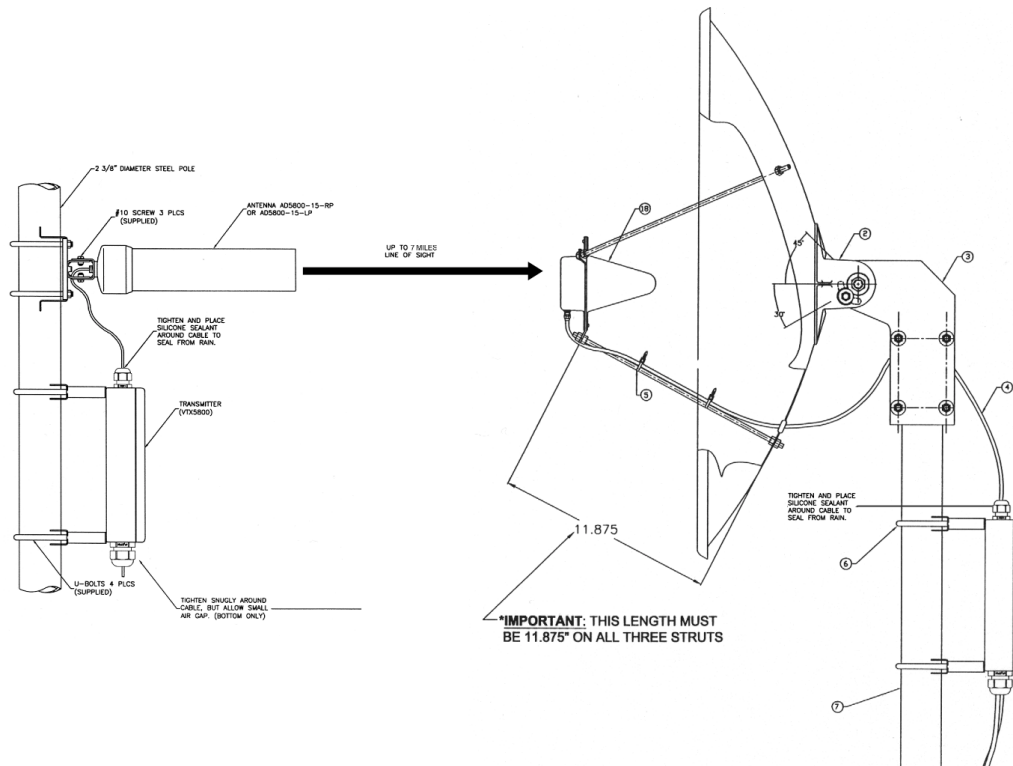

FIGURE 1c

Figures 1b and 1c show the orientation of the antennas and mounting of the enclosures. Since the antennas are directional, they must be aligned towards each other as shown.

NOTE: Make sure that your camera and monitor/recorder work properly hardwired before attempting to install the wireless link.

Installation:

The FALCON PLUS system is factory-configured for operation on channel 1 with right and left audio operational.

To obtain the best picture quality and transmission distance, the following rules of thumb should be followed:

- 1) Mount the transmitter and receiver antennas above human and mechanical traffic, the higher the better. A 10 foot 2 3/8" diameter steel mast on top of a building is typical. Make sure that the mast is well grounded to earth ground with an 8 AWG or larger wire. For maximum range, the transmit and receive antennas must be 15 to 20 feet above all obstacles in the line of sight.
- 2) Keep the transmission path as open as possible. Objects such as walls and metallic objects near the transmission path reflect signals and may reduce the transmission distance.
- 3) Do not add additional lengths of cable to connect the receiver to the antenna as significant losses in signal and reduced transmission range will occur.
- 4) Keep the cable connecting the antenna to the receiver as short as possible.

The VTX5900 transmitter and VRX5900 receiver units come pre-mounted in a NEMA-4X rated aluminum enclosure which allows mounting of the unit outdoors.

Transmitter Operation

Figure 2 shows the interior of the VTX5900 transmitter and the functions of each control and input/output. Each control is described in greater detail below. This card is encased in a NEMA-4X rated aluminum/powdercoat enclosure. Do not remove the card from the enclosure.

IMPORTANT NOTE: The transmitter uses a non-standard jack to connect to the transmitter antenna. Any modification to this jack may void the user's authority to operate the equipment and will void the manufacturer's warranty.



CAUTION

DO NOT APPLY POWER TO THE TRANSMITTER WITHOUT THE ANTENNA SECURELY ATTACHED. DO NOT APPLY VOLTAGE TO THE ALARM PINS. DAMAGE TO THE UNIT MAY RESULT.

1. Power
2. Alarm 1/2 inputs
3. Right audio input
4. Left audio input
5. Stereo/Alarm switch
6. Data
7. Video input
8. Toggle/Standby
9. Status LED
10. Channel LEDs
11. Antenna connector
12. Header for use with optional LC-485/422

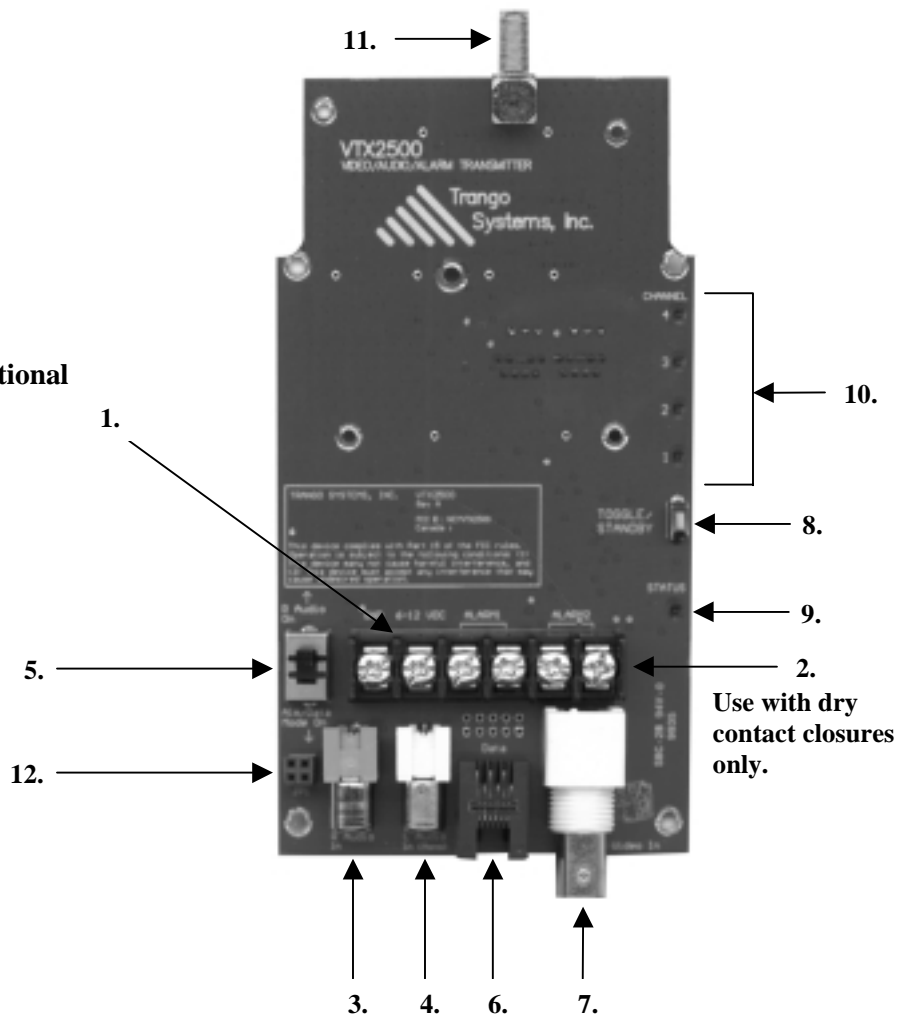

• FIGURE 2 •

VTX5900 Transmitter Inputs & Controls:

1. POWER INPUT

Accepts a 6-12 Vdc power source such as the standard 7 Vdc adapter (Trango part number PT07800-1), or an optional battery. The nominal current draw is 200 milliamperes. If using an adapter from a third party, use a well-regulated 300 mA minimum output supply. **Do not use the PT07800-1 to power a camera or video distortion may occur.**

2. ALARM INPUTS

These inputs are used to send alarm signals to the receiver. They sense an open or closed state and reflect that state to the receiver whenever it changes. The alarm inputs operate independently of each other. The transmitter is capable of sending *either* alarms *or* stereo audio, selectable via the Stereo/Alarm switch.

3/4. RIGHT & LEFT AUDIO INPUTS

Designed to mate to standard RCA connectors, each input accepts 1 Vpp audio input and is terminated with 600 Ω unbalanced configuration. It is designed to interface to "lineout" audio sources. A preamplifier must be used to connect a microphone to this input.

5. STEREO/ALARM SWITCH

When this switch is in the "R Audio On" position, stereo audio transmission is enabled. This permits the transmission of stereo audio with no data or alarms. When it is in the "Alm/Data Mode On" position, R audio is disabled. In its place, either alarms or user data (Data Pass-Through mode) are transmitted.

6. DATA INTERFACE

When connected to a personal computer via the optional CBLDAT-1 interface cable, this input accepts serial commands that control settings in the transmitters not available on the front panel. See the TrangoLink software section and program help for more information. This is also the input for the RS-232 user data to be sent in Data Pass-Through mode.

7. VIDEO INPUT

Designed to mate to a standard BNC male connector, this input accepts 1Vpp video in both NTSC and PAL formats. This input is terminated with 75 Ω . RCA-BNC adapters are available for use with some cameras and VCRs.

8. TOGGLE/STANDBY

Depressing this switch momentarily changes the transmitter channel. Remember to change the receiver channel as well, since it is not automatically changed when the transmitter channel is changed. Holding the button down for 2 seconds places the transmitter in Standby mode.

9/10. STATUS/CHANNEL LEDs

These LEDs display the transmitter status and current transmitter channel. There are 12 channels to choose from.



CAUTION

DO NOT APPLY EXTERNAL VOLTAGES TO THE ALARM INPUTS AS PERMANENT DAMAGE TO THE UNIT MAY RESULT. USE ONLY DRY CONTACTS WITH THESE INPUTS.

VTX5900 Transmitter Operation:

Changing Channels:

To change channels, simply depress the Toggle/Standby switch momentarily until the LED(s) for the desired channel is lit up. Remember to change the receiver channel as well, since it is not automatically changed when the transmitter channel is changed. As a rule of thumb, the first 6 systems operating along the same transmission path should be set to use even channels (2,4,6,8,10,12). If more than 6 systems are required along the same transmission path, use opposite polarization antennas and then set the units to operate on the odd channels (1,3,5,7,9,11). Contact Trango Tech Support for additional help on setting the correct configuration for your application.

Standby Mode -- Secure Standby Mode:

In this mode of operation the transmitter:

1. stops transmitting over the air completely by shutting down the majority of its circuitry to save power, and
2. waits to be returned to Normal mode by one of the following:
 - a change in either Alarm input,
 - the Toggle/Standby switch, or
 - the TrangoLink software.

To enter Secure Standby mode, press and hold the Toggle/Standby switch for 2 seconds or use the TrangoLink software (See the TrangoLink section of this manual for more information). The Status LED will blink for about 1 minute to allow the operator to leave the area. During this time the alarms will not be sent to the receiver. After 1 minute, the alarm inputs will be active and the status LED will then blink to indicate that the unit is in Secure Standby mode.

To exit Secure Standby mode, momentarily press the Toggle/Standby switch or use the TrangoLink software. After exiting Secure Standby mode, the active channel LED will be on solid to indicate that the transmitter is now continuously transmitting again.

Standby Mode -- Power Save Standby Mode:

In Power Save Standby mode, the transmitter will awaken (enter Normal mode) for a user-selectable amount of time if an alarm is received over the Alarm 1 input. After this time has expired, the transmitter will reenter Standby mode. The amount of time after which the transmitter will reenter Standby mode can be set to any value between 1 and 255 minutes using the TrangoLink software. If zero is entered, the transmitter will be in Secure Standby mode, and will not reenter Standby mode after awakening. More information can be found in the TrangoLink section of this manual.

When the transmitter has been placed in Power Save Standby mode, the Alarm 1 input is treated as normally-closed. An open condition on this input will awaken the transmitter for the preset amount of time. The state of the Alarm 2 input does not affect the transmitter in Power Save Standby mode.

In Power Save Standby mode the transmitter:

1. stops transmitting over the air by shutting down the majority of its circuitry to save power,
2. periodically and momentarily powers up and transmits over the air, and
3. waits to be returned to Normal mode by one of the following:
 - an open condition on the Alarm 1 input,
 - the Toggle/Standby switch, or
 - the TrangoLink software.

To exit Power Save Standby mode, momentarily press the Toggle/Standby switch, or use the TrangoLink software. After exiting Power Save Standby mode, the active channel LED will be on solid to indicate that the transmitter is now continuously transmitting again. If the Power Save Timer is still enabled, the radio will go back to Power Save Standby when it times out again.

Data Pass-Through Mode:

The transmitter and receiver can be used to pass data at rates from 1200 to 9600 bps. (For optimum data transmission without losses, both the transmitter and receiver should be configured to pass or accept data at the same rate. The data rate and parity are configured using the TrangoLink software.) To enter Data Pass-Through mode, the illustrated switch should be placed in “Alm/Data Mode On.” Then, from the TrangoLink software, select “Pass-Through Mode.” Make sure both the VTX5900 and the VRX5900 have been configured for Data Pass-Through mode. The Right Audio channel will be disabled in this mode while the Left Audio channel can still transmit monaural audio. Alarms and Link Verification cannot be transmitted when in Data Pass-Through mode. Do not use CBLDAT-1 to send or receive data since it contains extra wires not used for normal data transmission.

Figure 3 displays the pinout diagram to connect to the RJ11 Data connector for RS-232 data pass-through.

To pass simplex (one way) RS-485 or RS-422 format serial data, use the LC485/422 available from your dealer. If using the LC485/422 converter, the data connector must not be connected to any cabling.

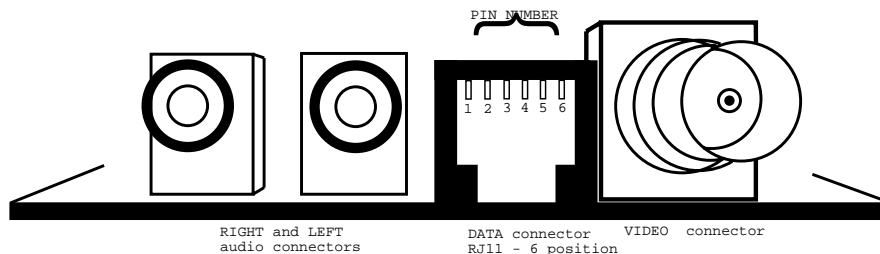

| PIN NUMBER | DESCRIPTION |
|------------|--------------------------------|
| 1 | Reserved -- DO NOT USE |
| 2 | RS-232 Serial Data In to Radio |
| 3 | GND |
| 4 | Reserved -- DO NOT USE |
| 5 | RS-232 Serial Data Out to PC |
| 6 | Reserved -- DO NOT USE |

• FIGURE 3 •

Low Battery:

If the input voltage drops below 6V, the status LED will blink twice per second. A low battery indication is also sent to the receiver and can be viewed using the TrangoLink software or the receiver. No alarm is generated.

Receiver Operation

Figure 4 shows the front panel of the VRX5900 receiver and the functions of each control and input/output. This card is encased in a NEMA-4X rated aluminum/powdercoat enclosure. Do not remove the card from the enclosure.

1. Power
2. Alarm 1/2 relay outputs
3. Right audio output
4. Left Audio output
5. Stereo/Alarm switch
6. Data
7. Video output
8. Toggle/RSSI
9. Channel LEDs
10. Antenna connector
11. Header for use with optional LC485/422

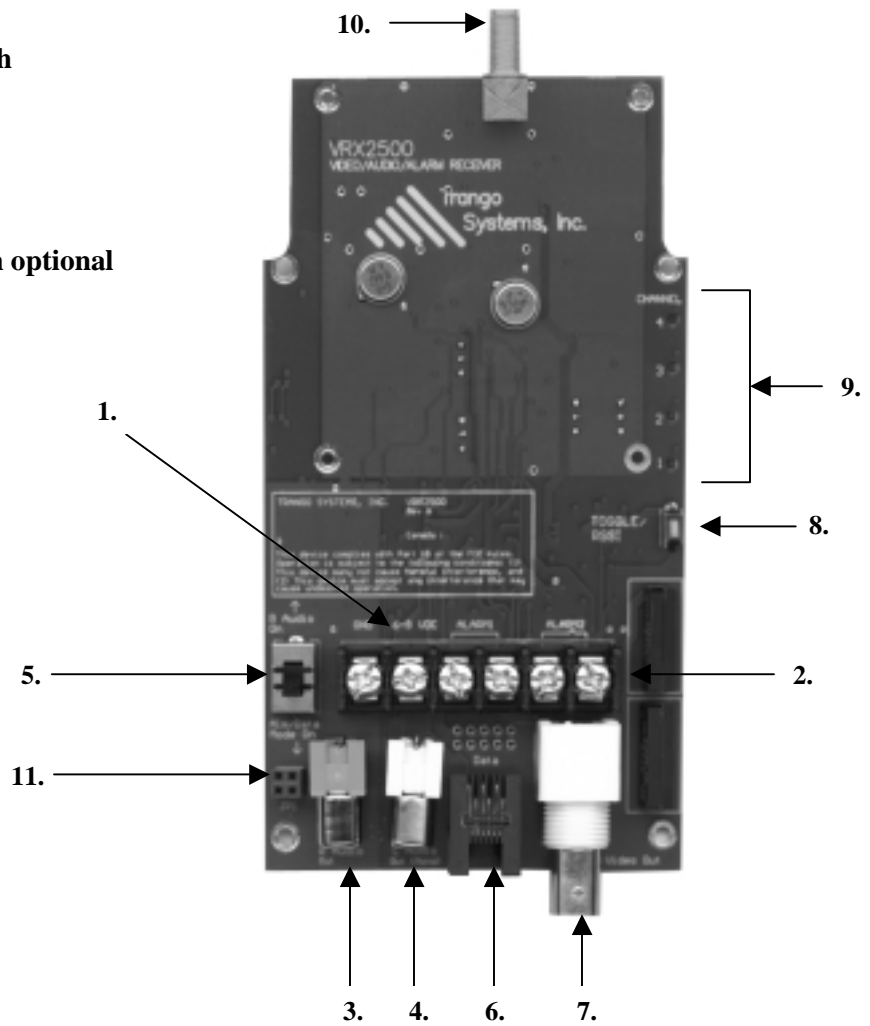

• FIGURE 4 •

VRX5900 Receiver Inputs/Outputs & Controls:

1. POWER INPUT

Accepts a 6-9 Vdc power source such as the standard 7 Vdc adapter (Trango part number PT07800-1), or an optional battery. The nominal current draw is 450 milliamperes. If using an adapter from a third party, use a well-regulated 6-9Vdc/500mA output supply.

2. ALARM OUTPUTS

These are dry contact relay outputs which can sink 1 ampere at 40 V AC/DC. When the corresponding transmitter alarm input closes or opens, this output will close and open as well. Consider these outputs mirrors of the transmitter alarm inputs. These outputs are independent and can be used to turn on peripheral devices such as video recorders and audible alarms.

3/4. RIGHT & LEFT AUDIO OUTPUTS

Designed to mate to a standard RCA male connector, this provides a 1.5 Volt peak-to-peak audio output and should be terminated in a minimum 600 Ω load, as is found in most "line in" audio inputs.

5. STEREO/ALARM SWITCH

When this switch is in the "R Audio On" position, stereo audio transmission is enabled. This permits the transmission of stereo audio with no data or alarms. When it is in the "Alm/Data Mode On" position, alarm transmission is enabled. If Data Pass-Through mode is enabled through the TrangoLink software, the switch must be set to the "Alm/Data Mode On position.

6. DATA INTERFACE

When connected to a personal computer via the optional CBLDAT-1 interface cable, this input accepts serial commands that control settings in the receiver not available via the front panel. See the TrangoLink software program help for more information. This port is also used for Data Pass-Through mode for RS-232 signal levels.

7. VIDEO OUTPUT

Designed to mate to a standard BNC male connector, this provides a 1 Volt peak-to-peak video signal output. This must be terminated with 75 Ω . RCA to BNC adapters are available for use with some monitors and VCR inputs.

8. TOGGLE/RSSI

To change the receiver channel, depress this switch momentarily. Remember to change the transmitter channel as well since it is not automatically changed.

To enter RSSI (Received Signal Strength Indicator) mode, hold down this button for 2 seconds. The number of channel LEDs lit is an indicator of signal strength, which can aid in finding the best antenna position.

9. CHANNEL LEDs

These LEDs display the current receiver channel and act as a Received Signal Strength Indicator.



CAUTION

**DO NOT APPLY EXTERNAL VOLTAGES TO THE ALARM OUTPUTS.
PERMANENT DAMAGE TO THE UNIT MAY RESULT.**

VRX5900 Receiver Operation:

Changing Channels:

To change channels, simply depress the Toggle/Standby switch momentarily until the LED for the desired channel pattern is lit up. Remember to change the transmitter channel as well, since it is not automatically changed when the receiver channel is changed. As a rule of thumb, the first 6 systems operating along the same transmission path should be set to use even channels (2,4,6,8,10,12). If more than 6 systems are required along the same path, use opposite polarization antennas and then set the units to operate on the odd channels (1,3,5,7,9,11). Contact Trango Tech Support for additional help on setting the correct configuration for your application.

Alarm Outputs:

When the VRX5900 receives an alarm state change from the transmitter, it will close or open the corresponding alarm output. The state of the alarm outputs (open or closed) can be viewed using the TrangoLink software. If the transmitter is in Standby mode or the transmitted signal is lost, the receiver will hold the last received valid state of the alarms. The Alarm outputs are dry-contact relays.

RSSI Mode:

To ease alignment of the receiver antenna, the received signal strength may be viewed by placing the unit in RSSI mode. The LEDs will then act as a bar-graph indicator, with more LEDs lit for a stronger signal.

To enter RSSI mode, hold down the Toggle/RSSI button for 2 seconds. To exit, depress the button momentarily. The number of LEDs lit is a relative indication of signal strength to be used only to find the best antenna position. Viewing the received picture quality should be used in conjunction with this mode.

Data Pass-Through Mode:

The transmitter and receiver can be used to pass user data one-way from the VTX5900 to the VRX5900 at rates from 1200 to 9600 bps. (For optimum data transmission without losses, both the transmitter and receiver should be configured to pass or accept data at the same rate. The data rate can be configured using the TrangoLink software.) To enter Data Pass-Through mode, the Stereo/Alarm switch should be placed in "Alm/Data Mode On." Then, from the TrangoLink software, select "Pass-Through Mode." Make sure both the VTX5900 and the VRX5900 have been configured for Data Pass-Through mode. The Right Audio channel will be disabled in this mode while the Left Audio channel can still transmit monaural audio. Alarms and Link Verification cannot be transmitted when in Data Pass-Through mode. Do not use CBLDAT-1 to send or receive data since it contains extra wires not used for normal data transmission.

Please see the pinout diagram in Figure 3 for more information on wiring the data connector for RS-232.

Troubleshooting the Falcon Plus System

INTERFERENCE

If interference such as lines in the pictures is observed, changing the transmission channel may cure the problem.

Also, AC generators in close proximity to the transmitter or receiver may cause lines in the picture. Move the unit away from the source of the interference.

NO PICTURE

Check that the transmit and receive channels are set the same, and make sure the transmitter is not in Standby mode (slow, blinking LED), or that the battery is not low (fast, blinking LED).

Verify all connectors are tight.

POOR PICTURE QUALITY

Raise transmitter and receiver antennas above ground and away from obstacles and traffic, including foot traffic.

Use an optional high-gain dish antenna on the receiver. Verify all connectors are tight. Shorten the receiver antenna feed cable.

VIDEO TOO DARK

Make sure that any monitors/peripheral equipment connected to the video source are set to high impedance termination since the VTX5900 has a built-in 75 Ω termination.

VIDEO TOO BRIGHT

Make sure that the receiver video output line is terminated with 75 Ω .

CAN'T COMMUNICATE WITH TRANSMITTER OR RECEIVER USING TRANGOLINK

Perform a system reset by holding toggle switch down while applying power. All memory locations will be erased and the system will be reinitialized. All LEDs will light up to indicate a successful reset. Release the toggle switch.

Check the Technical Support section of our website at <http://www.trangosys.com/> for additional assistance.

TrangoLink Software with the FALCON PLUS System

PC Requirements & Installation:

In order to run TrangoLink, you will need Windows 95 or higher, 400 kB of free disk space, and one free 9-pin serial port.

To install:

The TrangoLink program which can be found at our website at <http://www.trangosys.com/> is a self-extracting and installing file. To install TrangoLink on your PC, simply download the file and double-click on it.

To uninstall:

1. Click on **Start**, then **Settings**, then **Control Panel**.
2. Double click on **Add/Remove Programs**.
3. Select TrangoLink, and click **Add/Remove**.

TrangoLink with the FALCON PLUS System:

The TrangoLink software allows the user to change the user settings on the FALCON PLUS transmitters and receivers. The software runs under the Windows 95 or higher PC platform and connects from COM1-4 to the Data interface on the transmitter or receiver via the CBLDAT-1 interface cable.

To enter the program, the user must apply power to the connected unit and run the TrangoLink program by clicking on the TrangoLink icon in **Start/Programs**.

After entering the program, a screen is displayed showing the current settings, which can be changed by the user.

Configuring the FALCON PLUS Transmitter:

Via the TrangoLink interface panel for the VTX5900 transmitter, the user can configure the following settings:

MENU CONTROLS:

File: Choosing this pull-down menu brings up three options:

Sound: This toggles the PC sound on and off, so that the PC can beep (or not) if a change in any of the indicators is received.

Select Port: This selects the serial port through which the PC is connected to the transmitter or receiver. The cable required to connect may be purchased from your Trango Systems sales representative.

Exit: Exits TrangoLink.

Link Verification: This option brings up a dialog box by which the Link Verification Code can be set. This is a 32-bit code sent from the transmitter to the receiver to verify that the signal is being received from the proper location. The link verification codes on the transmitter and receiver must match for reception of alarms or low battery signals. If the codes do not match video will still be received, but the user will be notified that it is not coming from the proper location.

Pass-Through Mode: Choosing this pull-down menu brings up the following dialog box shown in Figure 5 through which the data rate and parity can be chosen. To use this function, the Stereo/Alarm switch on the transmitter and receiver must be set to "Alm/Data Mode On."

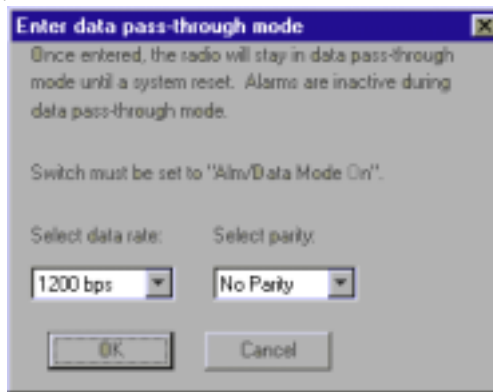

• FIGURE 5 •

Help: Choosing this pull-down menu brings up two options:

Help Topics: This offers you an index of online help topics.

About: This displays the copyright notice and version number of your copy of TrangoLink.

SCREEN CONTROLS:

Current Channel: This must be the same on the transmitter and receiver in order for video, alarms, and/or data to be transmitted properly.

Select Mode: The Normal button places the transmitter in Normal mode or awakens it from Standby mode. The Standby button places the transmitter in either Secure

Standby or Power Save Standby, depending on the value entered in the Power Save Timer field.

Power Save Timer: The FALCON PLUS can reenter Standby mode after a preset amount of time has passed, which can be entered in the Power Save Timer field (Power Save Standby mode). If zero is entered, the transmitter will not reenter Standby mode (Secure Standby mode). To enter a new value, type the desired number of minutes into the Power Save Standby field, and press the “Set new value” button.

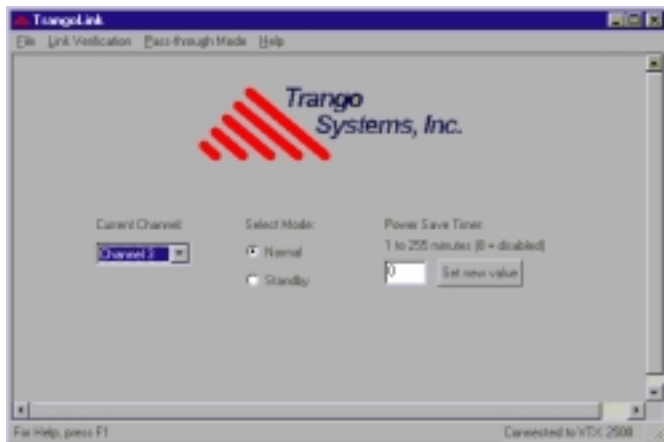

In Fig. 6, the TrangoLink interface screen shows that the transmitter is set to Channel 3, in Normal mode (not Standby), with the Power Save timer set to 0 minutes (Secure Standby). In this configuration, the transmitter will *not* reenter Standby mode after awakening.

Fig. 6

Configuring the FALCON PLUS Receiver:

Via the TrangoLink interface panel for the VRX5900 receiver, the user can configure the following settings:

MENU CONTROLS:

File: Choosing this pull-down menu brings up three options:

Sound: This toggles the PC sound on and off, so that the PC can beep (or not) if a change in any of the indicators is received.

Select Port: This selects the serial port through which the PC is connected to the transmitter or receiver. The cable required to connect may be purchased from your Trango Systems sales representative.

Exit: Exits TrangoLink.

Link Verification: This option brings up a dialog box by which the Link Verification Code can be set. This is a 32-bit code sent from the transmitter to the receiver to verify that the signal is being received from the proper location. The link verification codes on the transmitter and receiver must match for reception of alarms or low battery signals. If the codes do not match video will still be received, but the user will be notified that it is not coming from the proper location.

Pass-Through Mode: Choosing this pull-down menu brings up the following dialog box shown in Figure 7 through which the data rate and parity can be chosen. To use this function, the Stereo/Alarm switch on the transmitter and receiver must be set to "Alm/Data Mode On."

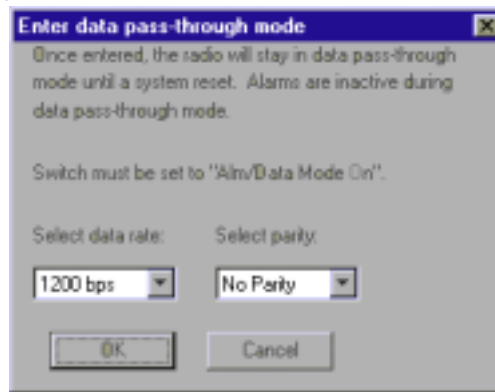

• FIGURE 7 •

Help: Choosing this pull-down menu brings up two options:

Help Topics: This offers you an index of online help topics.

About: This displays the copyright notice and version number of your copy of TrangoLink.

SCREEN CONTROLS:

Current Channel: This must be the same on the transmitter and receiver in order for video, alarms, and/or data to be transmitted properly.

Link Verification Error: Green indicates that the receiver is receiving a matching Link Verification Code from the transmitter. Red indicates that it is not.

Sync Loss: Green indicates that the receiver detects a vertical sync pulse on the received video signal. Red indicates that it does not, and hence that no video is being transmitted.

Low Transmitter Battery: Red indicates that the transmitter has a low power supply voltage (< 6 Vdc). Green indicates that power supply voltage is within acceptable limits.

Alarm 1 and Alarm 2: OPEN indicates that contacts are open on the receiver, CLOSED that they are closed.

Signal Strength: Also called **RSSI (Received Signal Strength Indicator)**. Presents a bar graph proportional to the received signal. Useful in troubleshooting to determine if any other signals are present in the frequency band and to help align antennas.

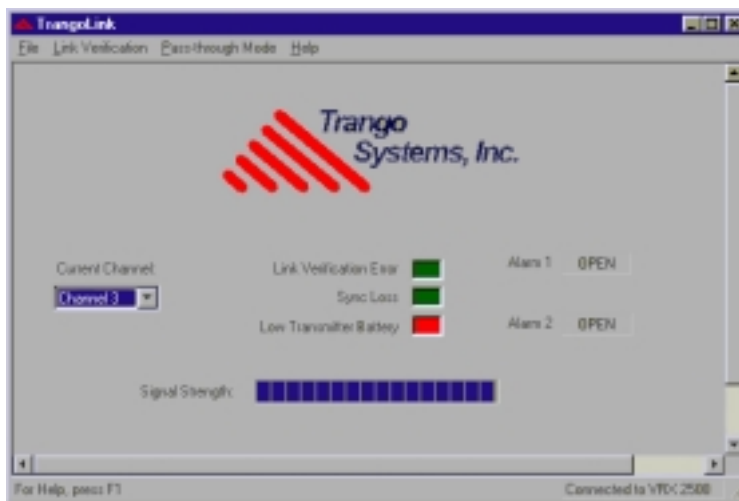

In Fig. 8, the TrangoLink interface screen shows that the receiver is set to Channel 3, both Alarms are open, and a low battery condition exists on the transmitter.

Fig. 8

Parametric Specifications

VTX5900 Transmitter: Electrical

RADIO SECTION:

| | |
|-------------------------|--|
| <i>Frequencies:</i> | Channel 1: 5740 MHz |
| | Channel 2: 5750 MHz |
| | Channel 3: 5762 MHz |
| | Channel 4: 5772 MHz |
| | Channel 5: 5784 MHz |
| | Channel 6: 5794 MHz |
| | Channel 7: 5806 MHz |
| | Channel 8: 5816 MHz |
| | Channel 9: 5828 MHz |
| | Channel 10: 5838 MHz |
| | Channel 11: 5850 MHz |
| | Channel 12: 5860 MHz |
| <i>RF Output Power:</i> | Meets FCC Part 15.249 radiated field strength of 50 mV/m at 3 meters with CP helix antenna provided with unit. |

VIDEO SECTION:

| | |
|--------------------------|--|
| <i>Input Level:</i> | 1 Vpp per NTSC/PAL standard |
| <i>Input Impedance:</i> | 75 Ω unbalanced |
| <i>Modulation:</i> | Wideband direct FM (for composite signal) |
| <i>Modulation Index:</i> | 1.0 at 8.0 MHz for composite A/V signal (± 8.0 MHz deviation) |
| <i>Pre-emphasis:</i> | CCIR Rec 405-1 |

AUDIO SECTION:

| | |
|--------------------------|---|
| <i>Input Level:</i> | 1 Vpp Nominal |
| <i>Input Impedance:</i> | 600 Ω |
| <i>Bandwidth:</i> | 50 Hz – 15 kHz (3 dB) |
| <i>Modulation:</i> | Wideband FM |
| <i>Subcarriers:</i> | 6.0 MHz (right) and 6.5 MHz (left-monaural) |
| <i>Modulation Index:</i> | 1.0 at 75 kHz for audio (± 75 kHz deviation) |
| <i>Pre-emphasis:</i> | 75 μ S |

ALARM SECTION:

Input Level: Normally open contact closure input on both Alarm 1 and Alarm 2. The current state of the input (open or closed) is transmitted to the receiver which reflects the transmitter alarm input states. DO NOT APPLY VOLTAGES TO THESE INPUTS AS DAMAGE TO THE UNIT WILL OCCUR.

POWER SECTION:

Input Voltage: 7 Vdc nominal, 6-12 Vdc range

Current Consumption: 200 mA typical in normal mode, 10 mA in Standby mode

Max. Ripple Input: 1 Vpp

Low Battery Sens.: < 6 Vdc

VTX5900 Transmitter: Mechanical & Environmental

GENERAL:

| | |
|------------------|---|
| <i>Material:</i> | Cast aluminum NEMA 4X rated outdoor enclosure |
| <i>Finish:</i> | Off-white powdercoat |
| <i>Size:</i> | 4.65" W x 8.8"L x 2.475"H without antenna |
| <i>Weight:</i> | 2.65 lb |

CONNECTORS & INDICATORS:

| | |
|------------------------|--|
| <i>RF Output:</i> | Custom connector in compliance with FCC rules part 15C, 15.203. |
| <i>FCC Compliance:</i> | The transmitter shall comply with FCC Part 15.249, FCC Part 15 Subpart B, Industry Canada Specifications (RSS 210 Issue 2) |
| <i>PC Interface:</i> | 6 position, 4 conductor RJ11 female right angle PCB mount |
| <i>Video:</i> | BNC female PCB mount |
| <i>Audio:</i> | Red RCA female PCB mount – R Audio White RCA female PCB mount – L Audio (Mono) |
| <i>Alarm/Power:</i> | 6 post terminal block (6-12 Vdc, GND, ALARM 1, ALARM 2) |
| <i>Controls:</i> | <i>Channel switch:</i> momentary, toggles through modes/channels <i>Stereo/Alarm switch:</i> DPDT switch allows selection of data/alarms or right audio on 6.0 MHz subcarrier |
| <i>Indicators:</i> | 4 channel LEDs which display the current channel, 1 Status LED which blinks slowly in Standby mode and rapidly when battery is low |

ENVIRONMENTAL:

| | |
|-------------------------|-----------------------------|
| <i>Operating Temp.:</i> | -20 to 70 °C |
| <i>Storage:</i> | -40 to 85 °C |
| <i>Humidity:</i> | 100% (enclosure) |
| <i>Shock:</i> | Sustain 3-axis drop from 5' |

VRX5900 Receiver: Electrical

VIDEO SECTION:

| | |
|----------------------------|---|
| <i>Video 3dB BW:</i> | 5.8 MHz (Conforms with NTSC/PAL standard) |
| <i>Video Output S/N:</i> | > 40 dB with -85 dBm RF input > 42 dB with -80 dBm RF input > 48 dB with -75 dBm RF input |
| <i>Video Diff. Gain:</i> | < 5% |
| <i>Video Diff. Phase:</i> | < 5 degrees |
| <i>Chr. To Lum. Gain:</i> | 70% to 107% |
| <i>Chr. To Lum. Delay:</i> | ±60 nS |
| <i>Output Load Imp.:</i> | 75 Ω |
| <i>DC Clamping:</i> | Back Porch with 0 V typical DC offset |

AUDIO SECTION:

| | |
|-----------------------------|-------------------------------|
| <i>Audio Bandwidth:</i> | 50 Hz to 15 kHz (3 dB) |
| <i>Harmonic Distortion:</i> | < 1% over 50 Hz to 15 kHz |
| <i>Audio Output S/N:</i> | > 12 dB with -85 dBm RF Input |
| <i>Output Load Imp.:</i> | 600 Ω |
| <i>Output Level:</i> | 1.5 Vpp typical |

ALARM SECTION:

| | |
|-----------------------|---|
| <i>Data Rate:</i> | 19,200 bps |
| <i>Coding Scheme:</i> | 32 bit command/address, 8 bit data with checksum |
| <i>Output Level:</i> | Reflects state of transmitter alarm inputs – updated twice per second |

POWER SECTION:

| | |
|-----------------------------|--|
| <i>Input Voltage Range:</i> | 7 Vdc nominal, 6-9 Vdc |
| <i>Max. Ripple Input:</i> | 1 Vpp |
| <i>Current Consumption:</i> | 450 mA nominal in receive mode and RSSI mode |

DATA PASS THROUGH MODE:

| | |
|------------------------------|--|
| <i>Protocol:</i> | Simplex, 3-wire, RS-232 levels, using serial port |
| <i>Serial Port Settings:</i> | 1200, 2400, 4800, 9600 bps with adjustable parity (even, odd, none –8,N,1 Standard), configurable with TrangoLink software |
| <i>Latency:</i> | < 15 mS end to end |
| <i>BER:</i> | < 1E10 ⁻⁶ at –80 dBm input signal level |

Note: RS-422/485 interface available with optional daughter board.

VRX5900 Receiver: Mechanical & Environmental

GENERAL:

| | |
|------------------|---|
| <i>Material:</i> | Cast aluminum NEMA 4X rated outdoor enclosure |
| <i>Finish:</i> | Off-white powdercoat |
| <i>Size:</i> | 4.65" W x 8.8"L x 2.475"H without antenna |
| <i>Weight:</i> | 2.65 lb |

CONNECTORS & INDICATORS:

| | |
|------------------------|--|
| <i>RF Input:</i> | SMA female connector |
| <i>FCC Compliance:</i> | The receiver shall comply with FCC Part 15.203, FCC Part 15.207(a), FCC Part 15 Subpart B, Industry Canada Specifications (RSS 210 Issue 2) |
| <i>PC Interface:</i> | 6 position, 4 conductor RJ11 female right angle PCB mount |
| <i>Video:</i> | BNC female PCB mount |
| <i>Audio:</i> | Red RCA female PCB mount – R Audio White RCA female PCB mount – L Audio (Mono) |
| <i>Alarm/Power:</i> | 6 post terminal block (6-9 Vdc, GND, ALARM1, ALARM 2) |
| <i>Controls:</i> | <i>Channel switch:</i> momentary, toggles through modes/channels <i>Stereo/Alarm switch:</i> DPDT switch allows selection of data/alarms or right audio on 6.0 MHz subcarrier |
| <i>Indicators:</i> | 4 channel LEDs which display the current channel |

ENVIRONMENTAL:

| | |
|-------------------------|-----------------------------|
| <i>Operating Temp.:</i> | -20 to 70 °C |
| <i>Storage:</i> | -40 to 85 °C |
| <i>Humidity:</i> | 100% (enclosure) |
| <i>Shock:</i> | Sustain 3-axis drop from 5' |
