



TECHNICAL MANUAL

v1.0 April 2012

FM BROADCAST TRANSMITTER

EM 500 HE DIG PLUS COMPACT

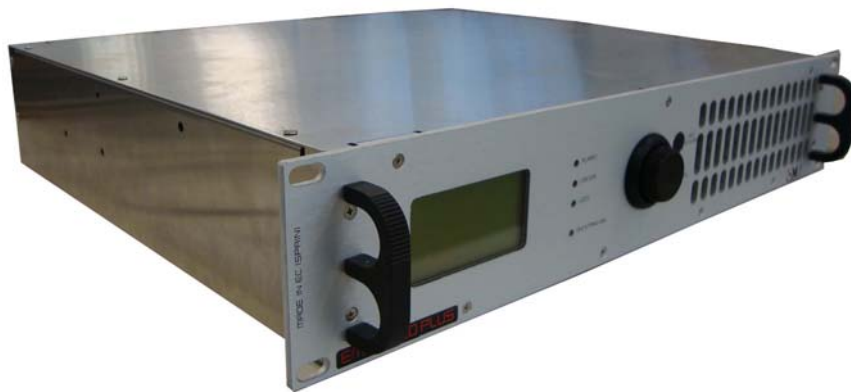

OMB EUROPE



Certif. n° ES08-002-A



Certif. n° ES08-002-B

Poligono Industrial Centrovía
Calle Paraguay, 6
50198 - La Muela
Zaragoza, ESPAÑA

Telf. : +34 976 14 17 17
Fax: +34 976 14 17 18

Web: <http://www.omb.es>
E-mail: europa@omb.com

OMB USA

3100 NW 72nd. Avenue Unit 112
MIAMI, Florida 33122 USA

Telf.: (305) 477 0973
(305) 477 0974
Fax: (305) 477 0611

Web: <http://www.omb.com>
E-mail: usa@omb.com



OMB ESPAÑA
Polígono Industrial Centrovía
Calle Paraguay, 6
50196 - La Muela
Zaragoza (ESPAÑA)

Ph: +34 976 14 17 17
Fax: +34 976 14 17 18

Web: <http://www.omb.es>
E-mail: europa@omb.com



Certif. nº ES08-002-A



Certif. nº ES08-002-B

LIMITED WARRANTY

About Installation

1. - Mains Voltage must be kept between $\pm 10\%$ about its nominal value, unless otherwise specified. If were variations exceeding this tolerance, it will be indispensable to install a voltage stabilizer system within station. If transient overvoltages, due to electric motors, or other devices of this sort connected to the distribution line, were present, or if the distribution line is exposed to atmospheric electrical discharges, it must be indispensable the installation of isolation transformers and gaseous dischargers before connecting any equipment within station.
2. - All equipments must be connected to station ground system in order to avoid damage both to equipments and maintenance personnel too. It is necessary to connect a differential automatic switch (lifesaver) at station.
3. - Some equipments does not include interlock protection for open doors, covers or connectors. In that case, these equipments must be kept in key -locked places, with access only to conveniently qualified personnel that is previously noticed about not to open doors, covers or connectors without disconnecting station mains switch before performing this job.
4. - Transmitter equipments NEVER will be operated with output powers over its nominal values, or with signals or input informations others than those specified in its individual characteristics.
5. - Ambient temperature inside equipments' room, will accomplish technical specifications of equipments installed at station lodge. In absence of such specifications, maximum allowable temperatures will be from -5 to $+ 45^{\circ}\text{C}$ for Television equipments, and from 0 to $+ 40^{\circ}\text{C}$ for Sound Broadcast equipments.
6. - In case of operation at abnormally high or extremely high temperatures (over 30 to 40°C), it is obligatory to install a forced cooling system that will keep temperature below its upper limit. In case of operation at abnormally or extremely low temperatures, it will be obligatory to install a thermostatic controlled heating system for equipment's room.
7. - Both equipment's surroundings and room must be free of dust and dirt. Ambient relative humidity will be kept below equipment's extreme specifications. In case of absence of this specification, allowable maximum will be 90% of relative humidity, non-condensing. Average relative humidity will be kept under 70% , non-condensing.
8. - Every transmission equipment that can radiate some quantity of RF power, must be connected to a load or antenna system, suited to its individual specifications , before being energized.
9. - Maximum allowable VSWR in antenna systems both for Television or FM Radio Broadcast operation of a given transmitter, will be $1.25:1$, unless otherwise specified.
- 10.- For those transmitter equipments having power valve amplifiers, and that doesn't has an automatic shutoff cycle, and must be manually turned off, as a first step high voltage, or anode voltage, will be disconnected, keeping forced cooling system working during at least 5 minutes after high voltage disconnection, and only after this time, cooling system & filament voltage can be shutted off. O.M.B. Sistemas Electrónicos, S.A., is not responsible of damages to those power valves caused by sudden AC mains failures at station where our equipments are installed.
- 11.- Periodically, monthly as a maximum, technical personnel must visit station in order to perform a general equipment maintenance, unless otherwise specified. This maintenance will include output power check, VSWR of antenna systems, forced cooling or heating systems

checks, both for equipments and station itself, including air filters cleaning, measuring of transmission frequency with eventual correction if necessary, and will perform a general check of fundamental parameters of equipments. In the event of any important change in some operation parameter, that will require replacement or readjustment of any unit, Customer **MUST CONTACT FIRST WITH O.M.B. SISTEMAS ELECTRONICOS, S.A. BEFORE ANY ATTEMPT TO READJUST OR REPLACE ANY COMPONENT OR UNIT INSIDE EQUIPMENTS, IN ORDER TO KEEP VALID THIS WARRANTY.**

12.- For equipments who are located in fixed racks or cabinets, those equipments must be effectively connected, according to International Installations Standards, to station ground system, whose total impedance measured to ground can't be higher than 5 ohms. Equipments must be connected to ground system so that they can be kept out of main discharge path between tower and ground.

About Transportation

1. - O.M.B. Sistemas Electrónicos, S.A. is not responsible of damages and/or detriments derived from mishandling, steal, robbery, theft or vandalism during the act of transportation of equipments to final or intermediate destination.

About Storage

1. - O.M.B. Sistemas Electrónicos, S.A. is not responsible of damages and/or detriments derived from unappropriate storage of equipments, within inadequate warehouses or outdoors, once equipments are delivered to transportist agency.

About Projects

1.- O.M.B. Sistemas Electronicos, S.A. is not responsible of inadequate use of equipments made or registered by our Company, accomplishing propagation projects that are not performed by our Specialists.

About Systems

1.- O.M.B. Sistemas Electrónicos, S.A. is not responsible for performance of those equipments or systems that are not made, certified or registered by our Company.

About Operation

1.- O.M.B. Sistemas Electrónicos, S.A. is not responsible of damages and/or detriments derived from inadequate or negligent operation of equipments made, certified or registered by our Company, once those equipments are operated by personnel hired and/or employed by Customer.

General

This Warranty covers and protects, during a period of 18 months after start of operations, all equipments made , certified or registered by O.M.B. Sistemas Electrónicos, S.A., including its components and units, against failures in workmanship that may occur during operation of those equipments, **with the exception of power valves or semiconductor devices** that are covered by its particular Factory's Guarantee. In this case, O.M.B. Sistemas Electrónicos, S.A. only can act as intermediary for negotiation with such Factory, about accomplishment of individual Guarantees.

For Validity of this Warranty, it is indispensable that all Paragraphs be respected by the Customer. Otherwise, this Warranty will be automatically voided. **This Warranty is self-activated with the reception by OMB Sistemas Electrónicos, S.A. of the "Guarantee Activation Manual" returned to OMB by Customer. If such Document is not received, this Warranty will be voided.**

All repairings or adjustments covered by this Warranty are free of workmanship & materials costs and expenses, but postage and transportation expenses of equipments and O.M.B. technical personnel & specialists, if required, will be carried out by the Customer.

O.M.B. Sistemas Electrónicos, S.A.

LIST OF CONTENTS

SECTION 0. GENERAL RECOMMENDATIONS 2

Gives information on safety procedures and good practices to use the equipment.

SECTION 1. INTRODUCTION 9

Introduction to the manual, technical specifications and description of the equipment's features.

SECTION 2. OPERATION 18

Contains a deep description of the system operation.

SECTION 3. INTERNAL MODULES 57

Contains the schematics of the different modules included in the equipment.

Section 0

GENERAL RECOMMENDATIONS

GENERAL SAFETY RECOMMENDATIONS

When connecting the equipment to the Mains power, please follow these important recommendations:

- This product is intended to operate from a power source that will not apply more than 10% of the voltage specified on the rear panel between the supply conductors or between either supply conductor and ground. A protective-ground connection by means of the grounding conductor in the power cord is essential for a safe operation.
- This equipment is also grounded through the grounding conductor of the power cord. To avoid electrical shock, plug the power cord into a properly wired socket before connecting to the product input or output terminals.
- Upon loss of the protective-ground connection, all accessible conductive parts (including parts that may appear to be insulated) can render an electric shock. **Equipment must be connected to station's ground system before any attempt to connect it to Mains electrical supply.**
- To avoid fire hazard, use only fuses of the type, voltage rating, and current rating specified in this manual. For fuse replacement, always refer to User's Manual.
- To avoid explosion, do not operate this equipment in an explosive atmosphere.
- To avoid personal injury, do not remove the product covers or panels. Do not operate the product without the covers and panels properly installed.

GOOD PRACTICES

During the maintenance of the equipment covered in this Manual, please keep in mind the following standard good practices:

- When connecting any instrument (wattmeter, spectrum analyzer, etc.) to a high frequency output, use the appropriate attenuator or dummy load to protect the final amplifiers and the instrument input.
- When inserting or removing printed circuit boards (PCBs), cable connectors, or fuses, always turn off power from the affected part of the equipment. After power is removed, allow sufficient time for the capacitors to bleed down before reinserting PCBs. **Always use discharge stick** when available.
- When troubleshooting, remember that FETs and other metal-oxide-semiconductor (MOS) devices may appear defective because of leakage between traces or component leads on the printed circuit board. Clean the printed circuit board and recheck the MOS device before assuming it is defective.
- When replacing MOS devices, follow standard practices to avoid damage caused by static charges and soldering.
- When removing components from PCBs (particularly ICs), use care to avoid damaging PCB traces.

FIRST AID AND EMERGENCIES

RESCUE BREATHING AND CPR

WARNING:

- Improper CPR or CPR performed on a person whose heart is still beating can cause serious injury. Never perform CPR unless:
 1. The person has stopped breathing.
 2. The person does not have signs of circulation, such as normal breathing, coughing, or movement in response to rescue breathing.
 3. No one with more training in CPR is present.
- CPR for infant or child through 8 years is not explained in this text.

Step 1: CHECK FOR CONSCIOUSNESS.



If you suspect a neck or spinal injury, do not shake the person. If the person does not respond:

Call 911 or other emergency services immediately (have someone else make the call if possible). Then proceed to Step 2.

Step 2: CHECK FOR BREATHING.

- Look, listen, and feel for breathing for 5 seconds. Kneel next to the person with your head close to his or her head.
- Look to see if the person's chest rises and falls.
- Listen for breathing sounds, wheezing, gurgling, or snoring.
- Put your cheek near the person's mouth and nose to feel whether air is moving out.
- If the person is not breathing (or if you can't tell), roll the person onto his or her back. If he or she may have a spinal injury, gently roll the person's head, neck, and shoulders together as a unit until the person is on his or her back.

Step 3: BEGIN RESCUE BREATHING.

- Place your hand on the person's forehead and pinch the person's nostrils shut with your thumb and forefinger. With your other hand, continue tilting the chin forward to keep the airway open.



circulation.

Take a deep breath and place your mouth over the person's mouth, making a tight seal. For an infant, place your mouth over the baby's mouth and nose. As you slowly blow air into the person, watch to see if his or her chest rises.

If the first breath does not go in, try tilting the person's head again and give another breath.

Slowly blow air in until the person's chest rises. Take 1 to 2 seconds to give each breath. Between rescue breaths, remove your mouth from the person's mouth and take a deep breath. Allow his or her chest to fall and feel the air escape.

- Give the person 2 full breaths. Then check for

Step 4: CHECK FOR CIRCULATION.



Look for signs of circulation, such as breathing, coughing, or movement in response to rescue breathing. If there are no signs of circulation, begin chest compressions. See Step 5. If there are signs of circulation, continue to give rescue breaths until help arrives or until the person starts breathing on his or her own. If the person starts breathing again, he or she still needs to be seen by a health professional.

Give rescue breaths:

- Adults (age 9 and older): 2 breaths every 15 seconds.

Step 5: BEGIN CHEST COMPRESSIONS.

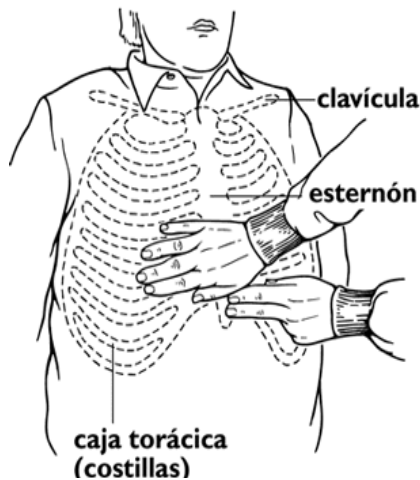

Kneel next to the person. Use your fingers to locate the end of the person's breastbone (sternum), where the ribs come together. Place 2 fingers at the tip of the sternum. Place the heel of the other hand directly above your fingers (on the side closest to the person's face).

Place your other hand on top of the one that you just put in position. Lock the fingers of both hands together, and raise the fingers so they don't touch the person's chest.



Straighten your arms, lock your elbows, and center your shoulders directly over your hands.

Press down in a steady rhythm, using your body weight and keeping your elbows locked. The force from each thrust should go straight down onto the sternum, compressing it 1 to 2 inches. It may help to count "one and two and three and four..." giving 1 downward thrust each time you say a number. Lift your weight, but not your hands, from the chest each time you say "and." Give 15 compressions.

After 15 compressions, give 2 full, slow breaths.

- Repeat the 15 compressions/2 breaths cycle 4 times (1 minute); then check again for signs of circulation. If there are still no signs of circulation, continue to give chest compressions and rescue breaths until help arrives or until signs of circulation are present and breathing is restored.

ELECTROCUTION

IN THE EVENT OF ELECTROCUTION DO **NOT** RUSH TO ASSIST THE VICTIM UNTIL YOU ARE CERTAIN THAT HE IS NO LONGER IN CONTACT WITH ELECTRICITY.

Otherwise the current will pass through the victim directly to you.

- If at all possible, turn off the source of electricity (i.e. light switch, circuit breaker, etc.) If this is not an option, use **non-conductive** material such as plastic or dry wood to separate the source of electricity from the victim.
- If the injuries appear serious or extensive, call to emergency number.
- Check the victim's vitals signs such as the depth of his breathing and regularity of his heart beat. If either one is effected by exposure to electricity or if the victim is unconscious, begin to perform **CPR**.

TREATMENT FOR BURNS

- Continue treating victim for electrical shock.
- Check for points of entry and exit of current.
- Cover burned surface with a clean dressing.
- Remove all clothing from the injured area, but cut around any clothing that adheres to the skin and leave it in place. Keep the patient covered, except the injured part, since there is a tendency to chill.
- Splint all fractures. (Violent muscle contractions caused by the electricity may result in fractures.)
- Never allow burned surfaces to be in contact with each other, such as: areas between the fingers or toes, the ears and the side of the head, the undersurface of the arm and the chest wall, the folds of the groin, and similar places.
- Transport the victim as soon as possible to a medical facility.

Section 1

INTRODUCTION

CONTENTS:

1.1 Introduction.	10
1.2 Technical specifications.11
1.3 Location of parts.12
1.4 Installation.14

1.1 Introduction.

The **EM 500 DIG PLUS** transmitter is equipped with the most modern technology available, to provide you with maximum performance at minimal performance cost, while fully conforming to technical regulations. Flexibility, quality, compactness, and low electrical consumption make the devices in the EM 500 DIG PLUS the best offered on the market today.

These are just a few of the advanced characteristics that make the EM 500 DIG PLUS truly unique:

- **Super-compact size and reduced weight**
- **Low performance costs.** The unique design reduces internal loss and allows the device to achieve an extremely high yield – typically greater than 80% - minimizing electrical consumption and thus decreasing performance costs.
- **Sturdy modular construction.** Reliable modular construction minimizes and facilitates maintenance operations. In addition, it ensures a greater average time between failures, as well as ease of maintenance.
- **Easy to use and to configure.** The transceiver uses a control interface, which is equipped with a large LCD screen, a multifunction knob, and few other buttons. This allows the user to easily set functions on the device, and to view the operating parameters in the blink of an eye.
- **Nominal RF output power over the full FM range particularly stable against time.** The output power may be varied from a minimum level and the operating frequency includes the full FM range, without retouching other parameters.
- **Power section entirely modular and highly reliable.**
- **RF output stage has a reverse intermodulation figure lower than the standard bipolar construction.** Low enough to approach that of tube equipment, due to the MOS-FET design.
- **Low level of dissipation.** The reduction in internal loss and overall elevated yield minimize the dissipation of heat; as a result, the devices in the EM 500 DIG PLUS perform well even in challenging environmental conditions.
- **Stable, reliable power supply.** The entire line of transmitters integrates the use of power sources with active power factor correction (PCF), as stipulated in recent regulations. As such, impact on the electrical power source is minimal, resulting in greater reliability over the entire device.
- **Easy diagnostics and easy-to-read parameters,** thanks to a comprehensive metering and alarms section on the LCD display. All parameters and alarms are easily accessible from remote posts via the remote control input, which allows the user to change from stand-by to “on air” in a fraction of a second. Upon request, an external controller can be provided for long range use of the device from an office or from other service points.
- **Compliance with the strictest regulations.** This device was designed in full compliance with CCIR, FFC, and other strict international regulations, as well as the recent, strict EC anti-magnetic noise requirements. In addition, this device complies with EC and ETSI 302.018-2 v 1.1.2.1 (2006-03) standards.

1.2 Technical Specifications.

Frequency range	87.5 - 108MHz
FM Modulation	75kHz (adjustable) peak deviation Mono 180kF3E Stereo 256kF3E
Audio/MPX Input Level	-3.5 to +12.5dBm @ 75kHz deviation
Audio Input Connectors	XLR Female
AES/EBU digital input connector (optional)	XLR Female, 110Ω balanced
Separation between channels (optional stereo generator)	60dB
Aux channel input level (RDS/SCA)	7.5 kHz deviation: -12.5 to 3.5dBm 2 kHz deviation: -24 to -8 dBm
Aux channel input impedance	10kOhm
Modulation distortion	7.5 kHz deviation: <0.05%, 0.02% typical 2 kHz deviation: <0.2%, 0.05% typical
Mono S/N ratio	30 to 20000Hz: >76dB, 86dB typical CCIR: >75dB, 81dB typical
Stereo S/N ratio	30 to 20000Hz: >72dB, 77dB typical CCIR: >68dB, 72dB typical
Audio channels bandwidth	30 to 15000Hz ± 0.1dB
Pre-emphasis time constant	Selectable, 25/50/75 microseconds
Nominal RF output power	500W
Consumption	713 VA (@ 500 W output power)
Transmitter tuning steps	10/100kHz
Output power ALC stability	±3%
Harmonics and spurious emissions	<80dBc
RF output impedance	50Ω
RF output connector	N type
RF sampler connector	BNC type
Power supply	110 - 230Vac ± 15%; 50/60Hz
Operating temperature range	0 to 40°C recommended -10 to 55°C max
Relative humidity	up to 95% not condensed

1.3 Location of parts.

1.3.1 Front panel description.

The front panel of the EM 500 DIG PLUS is shown in the next picture:

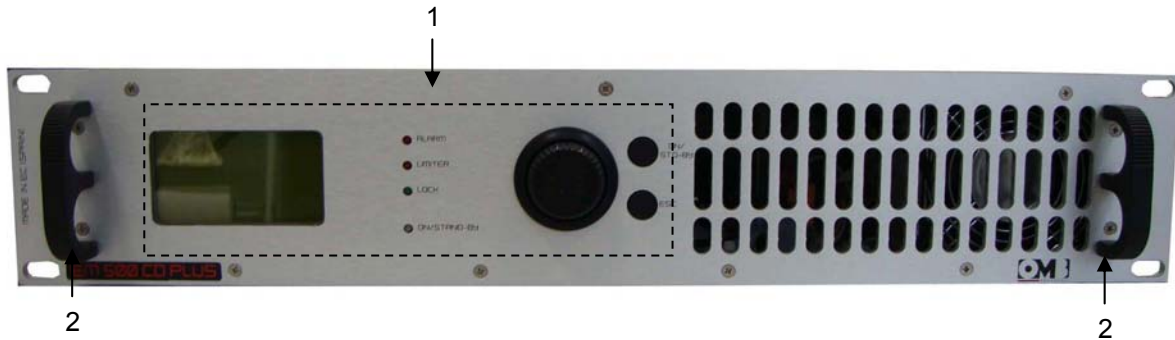

Figure 1.1: EM 500 DIG PLUS Front Panel

The elements shown in the previous figure are described next:

1. Control Panel. Allows the user to set device functions and to view and set operating parameters. It is composed of the following:

- **Liquid crystal display (LCD)** – a graphics display that shows the operating parameters and functions selected via the multifunction knob.
- **ALARM indicator light** (red) – this LED lights up in red if an alarm event occurs (e.g., output power or modulation too low).
- **LIMITER indicator light** (red) – this LED lights up in red to indicate that the maximum deviation limiter has activated due to an audio signal that is too high.
- **ON indicator light** (yellow/green) – this LED lights up two ways:
 - It lights up in yellow when the device is on stand-by
 - It lights up in green when the device is in operation (powered up).
- **LOCK indicator light** (green) – this LED lights up in green to indicate that the internal frequency synthesizer is locked on the set operating frequency.
- **Multifunction knob (encoder)** – allows the user to navigate the command menu in various ways:
 - If turned – selects the various functions/operations for the device, or the parameter values to be set.
 - If briefly pressed (like a button) when inside a menu – activates the option currently selected.
- **ESCAPE button** – while navigating through a menu, pressing this button will return the user to the previous level.
- **ON/STAND-BY button** – starts the device or puts it on stand-by.

2. Handles. Allow the user to easily pick up the device to remove it from or insert it into a mobile rack.

1.3.2 Rear panel description.

The rear panel of the EM 500 DIG PLUS is shown in the next picture:

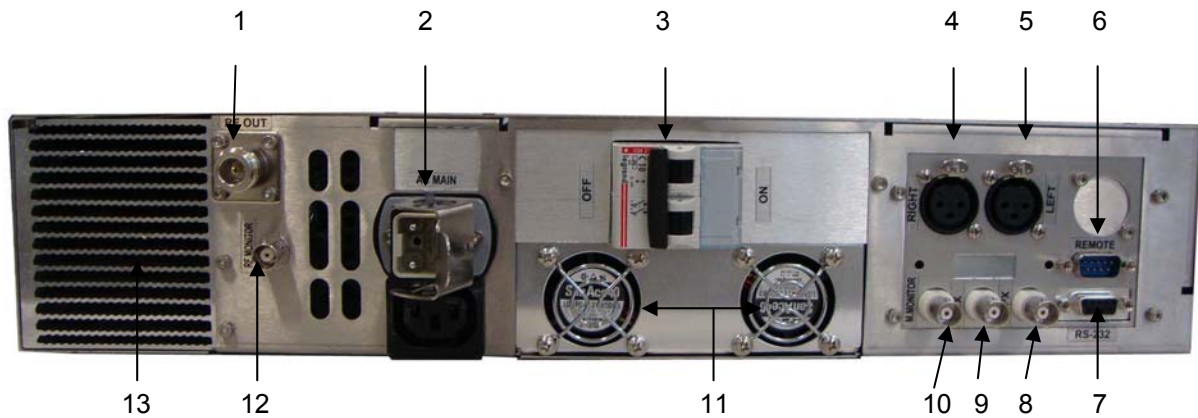

Figure 1.2: EM 500 DIG PLUS Rear Panel

The elements shown in the previous figure are described next:

1. **Antenna output socket/flange (RF OUTPUT)** – this socket/flange is connected to an FM broadcasting antenna that can tolerate the transmitter's nominal power.
2. **Power socket or cable** – used to connect to a mains supply.
3. **General power switch (POWER ON)** – allows the user to turn the general system power on and off.
4. **RIGHT** – balanced input (female XLR) for modulation of the right audio channel. This input can also accept a mono signal for monophonic transmissions.
5. **LEFT** – balanced input (female XLR) for modulation of the left audio channel.
6. **REMOTE control input** – this 9-pin SUBD connector allows the user to remotely control the device or to perform other functions via a suitable interface.
7. **RS232 serial programming port** – this female RS 232 Sub-D9 port with inverted cable allows the user to control the transmitter via a computer or an external point-to-point control device.
8. **MPX** – externally created broadband stereo composite modulating signal input (BNC-type unbalanced connector with grounding shield).
9. **AUX** – auxiliary modulating channel input (RDS/SCA) at low frequency on a 20-100 KHz band (BNC-type unbalanced connector with grounding shield) for connection to an RDS encoder.
10. **MODULATION MONITOR socket** – BF modulation output socket to be used as a monitor, for synchronization of the RDS encoder, or broadcast retransmission (BNC-type connector).
11. Power supply fans.
12. **Posterior RF MONITOR input** – BNC-type connector for sourcing the low level RF signal. The signal attenuation is 57 dB.
13. **Heat sink.**

1.4 Installation

1.4.1 Check the supplied parts

Before using your transmitter, ensure that the following parts are included in the package:

- The transmitter
- The user manual
- A power cable supplied with a suitable connector

If any parts are missing or damaged, contact your supplier at once.

1.4.2 General safety rules

Warning! In order to prevent serious damage to objects or people, the following rules must be strictly followed.

- Although no special instruments are required in most cases, the device should be installed by skilled personnel only. To make best use of the device and prevent damage to the unit, it is necessary to comply with the instructions outlined in this manual.

Should doubts or technical problems arise during the installation procedure, it is strongly recommended that you contact OMB or a local agent/dealer.

- Should technical problems or doubts of any kind arise during installation, OMB would be happy to provide qualified technical assistance. Technical intervention by personnel not authorized by OMB should not be performed.

- As a rule, the user should not access the inside of the device. Tampering with the factory settings renders our warranty null and void, and may also affect the device's performance, causing costly damage.

- No adjustments or internal calibrations are required for normal operations. The device must be properly grounded and must be used with all the covers closed in order to prevent electrical shocks and to fully comply with EC, EMI, and other safety regulations.

- Never touch the inside of the device without first disconnecting it from the mains. AC, DC, and radiofrequency voltages are present inside the device and can be dangerous when the covers are removed.

- Do not operate the device without the covers properly screwed into place. Using an open transmitter may be dangerous to objects or people. In addition, if the top cover is removed, this may cause the device or other electronic measurement instrument to perform incorrectly due to the elevated RF fields.

1.4.3 Placement of the device

- Choosing the proper room and placement

- Install the device in a dry, sheltered, well-ventilated room away from dust, moisture, insects, and rodents (mice).

- Room size should be such that the device can be placed in an upright position, and that technical personnel can easily perform routine or extraordinary maintenance. Evaluate the minimum size according to the power supplied by your model, taking into account that a volume of 2.5 x 2.2 m in

height is required for a transmitter with 1 KW of power, and that no other transmission or auxiliary devices should be present in the vicinity.

- Place the apparatus as close as possible to the antenna, in order to prevent excessive power loss in the cables. If this is not feasible, use antenna cables with low loss and suitable cross-section.
- Vents in the walls and any other openings must be fitted with metal gratings to keep rodents and insects out, and must be equipped with a dust filter. Make absolutely sure that no water can seep through the vents, the air exhaust duct, or the antenna cable grommet. Also confirm that the floor is not at risk of flooding during heavy rainfall.

- Climatic conditions

- In order to achieve optimum performance in terms of power, life span, etc., the ideal room temperature should range between 5°C and +25°C. As a general rule, the useful life span of the device may be halved by a 10°C increase in room temperature, should the temperature exceed 30°C. The pre-set over-temperature alarm will activate when the limit of 45°C is exceeded. It is advisable to hang a minimum/maximum thermometer on the wall to indicate variations in temperature.

- The room must be ventilated to ensure that the temperature never exceeds 35°C. Such conditions can NOT generally be met when the exhaust cooling air is not pushed outside and is instead fed back into the room. This is also occurring if more than one device is installed in the same location. An efficient ventilation system with air exchange is thus required in the room. For your reference, the air flow rate required for proper functioning of a 1 KW transmitter must be at least 500 cubic meters per hour.

Evaluate this element in proportion to the power supplied by the model you are installing.

- If the device is placed on a rack, the rear door of the rack can not usually be secured. If the system must be completely enclosed, a ventilation and air removal system must be created. To encourage air flow, a flange can be installed at the ventilation outflow, to which a hot air discharge conduit can be connected to the exterior. In this case, it is important to remember that the transmitter's internal fans are low pressure units and that it is fundamental for an exhaust fan to be installed on the air discharge conduit.

- The best solution is to keep the room at 20-25°C. Thermal insulation and effective ventilation via a fan controlled by a thermostat generally present the most advantageous solution.

- Excessive concentrations of moisture and/or dust in the air or in the room may cause a condensation build-up in the transmitter. If the system is periodically switched on and off, this can trigger destructive electric arcs and short circuits, and thus cause damage that is not covered by warranty.

- Electrical conditions

- The mains capacity must be proportionately designed to adequately support the device's power consumption (including a sufficient safety margin).

- The power supply nominal range comes from 100 to 265 VAC (nominal voltage single-phase 230 VAC).

- Mains fluctuations and electrical discharges due to weather or nearby industrial machinery may cause significant trouble, especially in mountain areas and in locations close to industrial areas.

- In such cases, it is advisable, if not indispensable, to install a protector, an insulating transformer, or possibly an electromechanical mains voltage regulator.

• Even though the mains regulator allows for a wide incoming voltage range, it is important to avoid operating using high impedance mains lines in proximity to the lowest permitted AC limit: if the line falls below a given value while fully loaded, the control circuit for the lowest AC limit may trigger a very dangerous oscillating on/off cycle. In such cases, we recommend using a stabilizer on the external line.

1.4.4 Wiring the device

This section describes the minimum connections required to place the transmitter in operation.

- Wiring into the antenna

Connect the **RF OUT** connector to the antenna or to the next RF amplifier via a high-quality 50 Ohm shielded coaxial cable equipped with the appropriate connectors.

It is indispensable that only low-loss cables be used when connecting directly to the antenna: in such cases, Celflex or another similar 1/2" cable is recommended. Larger cables must be connected using flexible terminal ends from the smallest section, in order to avoid mechanical stress on the output connector.

It is very important to ensure that the antenna, cables, and connectors have the correct impedance and are appropriate to the transmitter's nominal power level.

The antenna must be suitable for FM broadcasting and able to resonate at the operating frequency with the minimum possible SWR.

The antenna must be grounded via a copper braid of suitable cross-section to prevent lightning or static electricity from reaching the amplifier through the antenna cable.

- Connection to modulation signals

Connect the **LEFT** and **RIGHT** modulation inputs, or the **MPX** input alternatively, based on your desired operating mode (monophonic or stereophonic) and the type of source being used (mono, stereo, or multiplex signal).

The MPX connector is internally connected in parallel to the RIGHT connector. As such, if the MPX connector is in use, the simultaneous connection of signals to the LEFT and RIGHT connectors is not possible. Again in this case, the highest impedance position is 5 KOhm.

- Wiring into the mains

1) Verify that the rear power switch is turned off; if it is not off, do so now.

2) Ground the system.

3) According to your model, connect the power cable or the device's cable to a suitable single-phase input (230VAC nominal voltage).

Before connecting the power, ensure that it is appropriate and is able to support the consumption required by the transmitter model you intend to use.

Your transmitter should not be used when near the lower voltage limit with high-impedance lines: if the line voltage falls below a certain limit at full load, the low voltage sensor circuit could trigger a continuous, extremely dangerous on/off cycle. In such case, install an external voltage stabilizer.

In order to ensure proper operation and comply with safety regulations, proper grounding is required. Use the yellow/green lead in the power cable. The cable neutral lead is blue. Never connect the earth to the mains neutral lead.

Use only the power supply cable supplied with the transmitter. For cable extensions, sections of sufficient and appropriate length are recommended.

Never turn the device on without an antenna connection, even when in stand-by.

- Connection to the auxiliary modulation (optional)

Where necessary, an auxiliary RDS or SCA modulation source can be connected to the **AUX** input.

- Parallel port for remote control (optional)

Where necessary, connections can be made to the **REMOTE** parallel port. Various lines are located in this port for simple, direct control of the transmitter via a male DB9 connector.

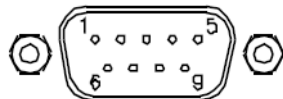

Connection of the pins is outlined in the following table:

Number	Connection
1, 5 and 8	Ground
2	On the air signal
3	Direct power
6	Disable RF
7	Alarm

- Connection to the RS232 port (optional)

Where necessary, connections can be made to the **RS232** port. This port manages Tx, Rx, and related return data signals via a RS232 standard without any “handshake” signal.

The above signals are inversely connected to the port; as such, a simple pin-to-pin type serial cable is sufficient, directly connected to suitable connectors, usually a female DB9 or DB25 on the PC port and a male DB9 connector to the transmitter. The applicable communication software is also required.

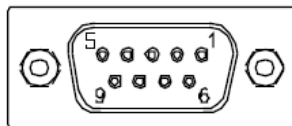

- Never connect the cable if the PC or the transmitter are turned on.

Section 2

OPERATION

CONTENTS:

2.1 Audio Operation Modes	19
2.2 Basic Operations	22
2.3 Menu and Navigation Commands	30
2.4 Description of the menu	33
2.5 Troubleshooting	55

2.1 Audio Operation Modes.

This section describes how to select the various available operating modes, and how to make audio connections according to your requirements.

The transmitter is equipped with numerous characteristics specific to high-fidelity systems; as such, it should be connected to modulating signals with the same care as a Hi-Fi system, avoiding ground loops as much as possible. Under these conditions, you will obtain optimal performance.

According to the operating mode and type of modulation source available, you can connect to the modulation inputs in various ways:

- Monophonic transmission from an audio signal, via the main mono channel
- Monophonic transmission from a stereophonic audio signal, using the internal stereo encoder
- Stereophonic transmission from a stereophonic audio signal, using the internal stereo encoder
- Monophonic or stereophonic transmission from an external encoder or radio link receiver.

The device is also able to transmit an auxiliary signal (RDS or SCA), connected to the rear AUX input as described below.

2.1.1 Mono transmission from a mono signal

- 1) Connect the **RIGHT** connector to the monophonic audio signal. Connection to the **LEFT** input is not necessary.
- 2) Using the **SETUP** menu, set the modulation mode to **Mono**.
- 3) Confirm or change pre-emphasis according to the local standard.

2.1.2 Mono transmission from a stereo signal

- 1) Connect the **RIGHT** connector to the right audio channel.
- 2) Connect the **LEFT** connector to the left audio channel.
- 3) Using the **SETUP** menu set the modulation mode to **Mono L+R**.
- 4) Confirm or change pre-emphasis according to the local standard.

2.1.3 Monophonic or stereophonic transmission from a multiplex signal

If you wish to use a multiplex signal (MPX) originating, for example, from an external encoder or a radio link receiver, follow the steps below:

- 1) Connect the multiplex signal to the **MPX** connector. The multiplex signal is already pre-emphasized; as such, using the MPX input, the filtering and stereo encoding stages are skipped and the signal will not be further preemphasized.
- 2) Using the **SETUP** menu, set the modulation mode to **Mpx**.

Selecting the preemphasis according to the local standard is not required, as it is irrelevant in this mode. However, it is recommended that this be done anyway.

If the length of the cable delivering the signal to the MPX connector is only a few meters long, a 50 Ohm (RG58) cable can be used. If the distance is greater, a 75 Ohm (RG59) or 92 Ohm (RG62) cable should be used.

2.1.4 Connection to LEFT, RIGHT, or MPX modulation connectors

The EM 500 DIG PLUS supports both balanced and unbalanced audio signals according to the connection that is made in the three **LEFT** and **RIGHT** XLR connector contacts. The input impedance for these contacts is pre-set at the factory at 10 KOhm resistivity (5 KOhm for unbalanced connections), which can be decreased to 600 Ohm if necessary, as explained further ahead.

Normally, an XLR audio input with balanced connection is used for connection to the balanced output of a professional mixer.

Alternatively, an unbalanced connection can be used, and is useful for output connections on inexpensive devices, without a perceptible degradation in the audio signal.

Alternatively to connection to the **LEFT** e **RIGHT** connectors, an externally created multiplex signal can be connected to the **MPX** connector. In this case, connection should not be made to the **LEFT** and **RIGHT** connectors.

The MPX connector is internally connected in parallel to the RIGHT connector. As such, if the MPX connector is in use, the simultaneous connection of signals to the LEFT and RIGHT connectors is not possible. In such case, the highest impedance position is 5 KOhm.

- Balanced connection to the LEFT and RIGHT connectors

The output for a mixer or any other audio processor that drives a transmitter with a balanced coaxial cable should be connected at pin 3 (-) and pin 2 (+). The cable shield, connected to the ground of the audio driver device, must be connected to pin 1.

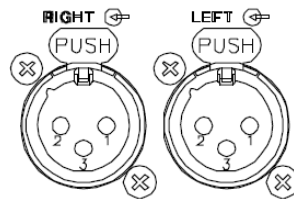

Balanced connection offers the greatest advantages. For example, cables connected to a source can greatly exceed 100 meters in length.

- Unbalanced connection to the LEFT and RIGHT connectors

For driving with an unbalanced signal, input pin 3 must be short-circuited with the ground and the shield to pin 1, while the signal must go to pin 2. In such case, the highest impedance selection will be 5 KOhm rather than 10 KOhm.

2.1.5 Connection to the MPX input

Connect an externally created multiplex signal to the MPX input using a suitable encoder.

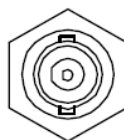

If the length of the cable delivering the signal to the MPX connector is only a few meters long, a 50 Ohm (RG58) cable can be used. If the distance is greater, a 75 Ohm (RG59) or 92 Ohm (RG62) cable should be used.

- Checking the pilot tone in stereophonic transmission

Where the internal stereo encoder is used, the level of the stereo driver tone, which is usually set internally at 9-10% of the modulation (from -21 to -20dB) corresponding to the standard established deviation of 7 – 7.5 kHz, cannot be changed externally.

Where the stereo modulation signal is externally generated by a separate stereo encoder, the driver tone must be measured in the absence of audio modulation and all other auxiliary signals, as described below:

- 1) Disconnect all signals from the external stereo encoder input, and any RDS or SCA signals.
- 2) Select the **VIEW - AUX** menu and confirm that the driver tone is now the only available signal. The standard level is as indicated above, 9-10% (-21 to -20dB), and can be consequently adjusted on the external stereo encoder as required.
- 3) Reconnect the previously disconnected signals.

2.1.6 Changing the input impedance

As previously explained, the input impedance on the modulation inputs can be changed. Selection of the input impedance is one of the very few settings that can only be changed internally, as follows:

- 1) Disconnect the mains.
- 2) Unscrew the screws that hold the top cover in place (16 or more cross-head screws will require removal, depending on the model).
- 3) Remove the top cover and store it in a safe place.
- 4) Identify the input card.

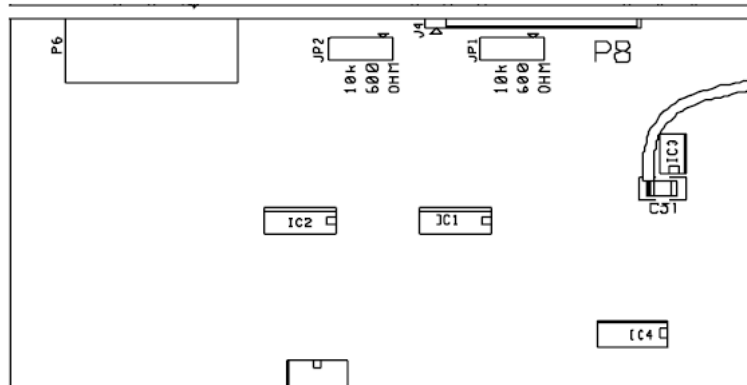

5) The input impedance is easily set using the **JP1** e **JP2** jumpers found on the input card, immediately after the input connectors as illustrated in the design. The selectable impedance values are serigraphed on the printed circuit board.

6) Place the top cover back on the transmitter, ensuring that all the screws are correctly screwed into place.

2.1.7 Pre-emphasis

The low frequency audio signals of mono and stereo channels must be properly “pre-emphasized”. The standard pre-emphasis is 50 or 75 μ s, the first value usually being the one selected during manufacture. Confirm that this value is appropriate in your country: it is the standard value for all countries in Europe,

most of the Pacific regions, and some countries in South America. However, the North American FCC standards require 75 μ s.

To make changes to the pre-emphasis, use the **SETUP** menu.

2.1.8 Operating with the RDS and SCA encoders

In addition to the aforementioned operating modes, this device is able to transmit an auxiliary signal (RDS or SCA) connected to the rear **AUX** terminal as follows:

- 1) Connect the **AUX** terminal to the RDS or SCA encoder output.

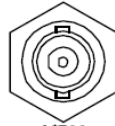

- 2) If the internal stereo encoder is used, connect the **MODULATION MONITOR** output to the “driver tone” synchronization input on the RDS encoder (where available).

- 3) Using the **SETUP - AUX SENS** menu, change the channel input sensitivity and, where necessary, the external generator level so as to obtain the required deviation. For RDS encoders, a reading of -11.5 dB or 2kHz is the standard modulation value.

- 4) Modulation and deviation can be viewed on the **STATUS** screen, in addition to any other multiplex signals available at that time.

If the length of the cable delivering the signal to the AUX terminal is only a few meters long, a 50 Ohm (RG58) cable can be used. If the distance is greater, a 75 Ohm (RG59) or 92 Ohm (RG62) cable should be used. The same is valid for connection to the MODULATION MONITOR input.

2.2 Basic Operations.

2.2.1 Initial start-up and basic adjustments

The first time the device is turned on, it is important to perform basic adjustments (frequency, output power, modulation, etc.) and verify that they are functioning correctly (e.g., reflected power) via the commands menu. This section explains how to perform these adjustments.

The transmitter stores in its memory the operating mode in which it was working before the power supply was turned off or a mains failure took place. Therefore, before continuing, it is important to ensure that it is connected to a load that is able to support the maximum deliverable power.

Operating the transmitter without an antenna, or when the antenna is improperly connected, may cause damage that is not covered by the warranty, particularly during the final stage of transmission.

If turning the transmitter on places it directly in operation (rather than on stand-by), we recommend that the ON/STAND-BY button be pressed to place the transmitter on stand-by while making adjustments.

Proper adjustment of the parameters should be made so as to conform to local regulations; such conformity is the full responsibility of the user.

If the device is left on the **SETUP** menu without receiving a command, the display will automatically return to the **STATUS** screen under the **VIEW** menu.

1) Ensure that all installation conditions are met, and that all the connections described have been made. You can connect a suitable dummy load to the transmitter's RF output instead of the antenna.

2) Turn on the device via the rear power switch. For a few seconds, the OMB logo will appear on the full screen; after this, the default screen will be displayed; the bottom of the default screen will show the two main menus, **VIEW** and **SETUP**.

3) At this point, two conditions are possible:

- **The transmitter begins to operate** (including possible powering up) – the display turns on, and the **ON** LED lights up in green. In such case, it is recommended that the basic settings be made, turning the transmitter on stand-by. To do so, press the ON/STAND-BY button. Ensure the **ON** LED lights up in yellow and skip directly to step 4).

- **The transmitter goes to stand-by** – the display turns on, and the **ON** LED lights up in yellow. At this point, proceed to the next step.

4) Turn the knob to select the main **SETUP** menu, and press briefly to confirm. The first of the three pages comprising the **SETUP** menu will appear:



2.2.2 Operating frequency

5) Ensure that the **FREQUENCY** sub-menu is selected; otherwise, turn the knob to select it.

6) Press the knob to access the sub-menu. The following screen will appear:



7) Ensure that the **EDIT** option is selected; otherwise, turn the knob to select it, then press to confirm.

8) A value will be indicated after **Step** (frequency steps).

9) Turn the knob until you select the frequency step required to exactly set the required operating frequency, then press the knob to confirm.

*Normally, it is sufficient to leave it at **100KHz** (e.g., operating frequency of 91.50 MHz). Otherwise, if the operating frequency is defined at a step lower than 100 KHz (e.g., operating frequency of 97.850 MHz), you will need to select the 10 KHz step.*

10) A value will be indicated after **Frequency**. Turn the knob until you reach the exact operating frequency desired, then press the knob to confirm.

11) **OK** will be highlighted. Three choices are now available:

o If the parameters set are correct – skip directly to step 12) to confirm the settings.

o If the parameters set are all incorrect – cancel all settings by turning the knob until **ABORT** is highlighted, then skip to step 12).

o If a slight adjustment to the parameters is required – turn the knob until **EDIT** is highlighted, then return to step 8.

12) Press the knob to confirm. You will return to the page indicated in step 3).

2.2.3 RF output power

13) Turn the knob until the **POWER** sub-menu is selected, then press to confirm. The power adjustment screen will appear:



14) Ensure that the **EDIT** option is selected; otherwise, turn the knob to select it, then press to confirm.

15) A value will be indicated after **Pow. Set**:

16) Turn the knob until the desired power is set, then press the knob to confirm.

17) Okay will be highlighted **OK**. Three choices are now available:

o If the parameters set are correct – skip directly to step 18) to confirm the settings.

o If the parameters set are all incorrect – cancel all settings by turning the knob until **ABORT** is highlighted, then skip to step 18).

o If a slight adjustment to the parameters is required – turn the knob until **EDIT** is highlighted, then return to step 15).

18) Press the knob to confirm. You will return to the page indicated in step 3).

□ If the device is currently in operation (green **ON LED** lit up), the **Pow. out:** indicator will show the power currently supplied.

Otherwise, with the device on stand-by (yellow **ON LED** lit up), the indicator will remain at **0.0W**.

2.2.4 Modulation sensitivity

19) Turn the knob until the **MPX SENS.** sub-menu is selected, then press the knob to confirm.

20) The modulation sensitivity adjustment screen will appear:

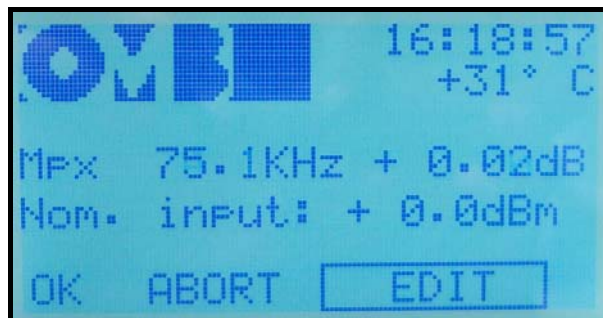

21) Ensure that the **EDIT** option is selected; otherwise, turn the knob to select it, then press to confirm.

22) A value will be indicated after **Nom. Input**, normally pre-defined at **+0.0 dBm**.

23) Turn the knob to adjust the value based on the modulation level used. The peak deviation indicated by **Mpx**, expressed in KHz, will consequently be changed. Note that, to the right of the deviation, the value of the modulating signal will be indicated, as compared to the nominal value set.

24) Ensure that the measured peak deviation does not exceed local regulations, then press the knob to confirm the setting.

25) **OK** will be highlighted. Three choices are now available:

o If the parameters set are correct – skip directly to step 26) to confirm the settings.

o If the parameters set are all incorrect – cancel all settings by turning the knob until **ABORT** is highlighted, then skip to step 26).

o If a slight adjustment to the parameters is required – turn the knob until **EDIT** is highlighted, then return to step 22).

26) Press the knob to confirm. You will return to the page indicated in step 3).

2.2.5 Modulation limiter

27) Turn the knob until the **LIMITER** sub-menu is selected, then press the knob to confirm.

28) The modulation limiter adjustment screen will appear:



29) Ensure that the **EDIT** option is selected; otherwise, turn the knob to select it, then press to confirm.

30) A value will be indicated after **Limiter**. This indicator is normally followed by **OFF** or by the limiter intervention value, expressed in dB, in reference to a deviation of 75 KHz.

31) Turn the knob to set the desired value (0 dB = limiter intervention of 75 KHz), then press the knob to confirm.

32) **OK** will be highlighted. Three choices are now available:

o If the parameters set are correct – skip directly to step 33) to confirm the settings.

o If the parameters set are all incorrect – cancel all settings by turning the knob until **ABORT** is highlighted, then skip to step 33).

o If a slight adjustment to the parameters is required – turn the knob until **EDIT** is highlighted, then return to step 30).

33) Press the knob to confirm. You will return to the page indicated in step 3).

When the limiter begins to intervene, the modulation distortion increases. As such, the modulation sensitivity should be adjusted so the limiter intervenes sporadically. Using this approach, its operation is generally imperceptible.

*When the limiter activates, the **LIMITER** LED lights up in red.*

2.2.6 Transmission modes (mono/stereo) and pre-emphasis

34) Turn the knob until the **MODE** sub-menu is selected, then press the knob to confirm.

35) The transmission mode settings screen will appear:

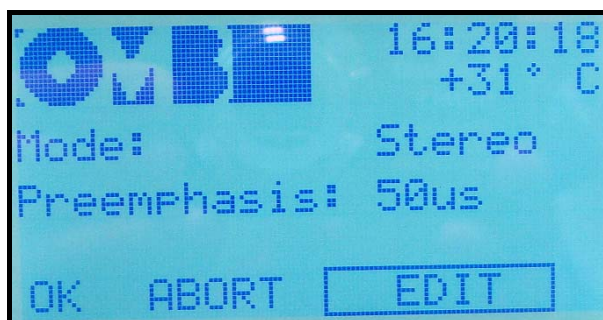

36) Ensure that the **EDIT** option is selected; otherwise, turn the knob to select it, then press to confirm.

- 37) A value will be indicated after **Mode**. This indicator is normally followed by the operating mode (mono, stereo, mono L+R, or Mpx).
- 38) Turn the knob until the desired setting is selected, based on your needs, then press the knob to confirm.
- 39) A value will be indicated after **Pre-emphasis**. Turn the knob until the pre-emphasis value for your geographical region is selected (50 microseconds in Spain), then press the knob to confirm the value.
- 40) **OK** will be highlighted. Three choices are now available:
- o If the parameters set are correct – skip directly to step 41) to confirm the settings.
 - o If the parameters set are all incorrect – cancel all settings by turning the knob until **ABORT** is highlighted, then skip to step 41).
 - o If a slight adjustment to the parameters is required – turn the knob until **EDIT** is highlighted, then return to step 37).
- 41) Press the knob to confirm. You will return to the page indicated in step 3).

2.2.7 System date and time

Setting the date and time is important because it allows the transmitter to keep track of events (alarms, etc.) that occur while the transmitter is operating. Set the date and time as follows:

- 42) Turn the knob until the **NEXT PAGE** sub-menu is selected, then press the knob to confirm. The display will indicate the second page of the **SETUP** menu:



- 43) Turn the knob until the **DATE TIME** sub-menu is selected, then press the knob to confirm.
- 44) The date and time settings screen will appear:

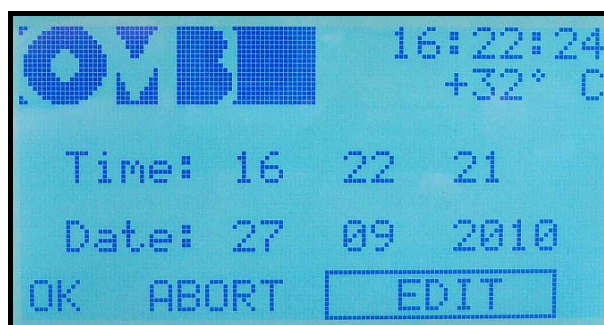

- 45) Ensure that the **EDIT** option is selected; otherwise, turn the knob to select it, then press to confirm.
- 46) The hour will be indicated after **Time**. Turn the knob and adjust the current hour, then press the knob to confirm.
- 47) The minute will be indicated. Turn the knob to adjust the current minute, then press to confirm.
- 48) The second will be indicated. Turn the knob to adjust the current second, then press to confirm.
- 49) The day of the month will be indicated after **Date**. Turn the knob to set the current day, then press to confirm.
- 50) The month will be indicated. Turn the knob to set the current month, then press to confirm.
- 51) The year will be indicated. Turn the knob to set the current year, then press to confirm.
- 52) **OK** will be highlighted. Three choices are now available:
 - o If the parameters set are correct – skip directly to step 53) to confirm the settings.
 - o If the parameters set are all incorrect – cancel all settings by turning the knob until **ABORT** is highlighted, then skip to step 53).
 - o If a slight adjustment to the parameters is required – turn the knob until **EDIT** is highlighted, then return to step 46).
- 53) Press the knob to confirm. You will return to the **SETUP** menu screen indicated in step 42).

2.2.8 Changing from stand-by to full operation

The transmitter is thus programmed with the basic parameters. You can now return to the default screen by pressing the **ESCAPE** button. Of course, you may now need to adjust other parameters, according to your requirements (e.g., modulation of the auxiliary RDS/SCA signal).

Once you are sure that you've correctly programmed all the parameters, you can place the transceiver in full operation by pressing the **ON/STAND-BY** button. Ensure that the **ON** LED is lit up in green.

If the red ALARM indicator light appears, this means that an alarm event has occurred. When this happens, check the type of alarm on the display, refer to the error table, and solve the problem.

2.2.9 Checking parameters

We recommend that all the operating parameters be verified the first time that the transceiver is placed in full operation, via the **VIEW** menu. To access this menu from the default screen:



- 54) Turn the knob to select the main **VIEW** menu, then press to confirm.
55) The first page composing the **VIEW** menu will appear:



- 56) Verify that all parameters are correct, in particular:
- o Direct and reflected power, via the STATUS sub-menu.
 - o Modulation, via the L/R and MPX GRAPH sub-menus.
 - o Operating frequency, mono/stereo mode, and pre-emphasis, via the SYSTEM sub-menu.
 - o Internal temperatures, via the TEMPERAT. sub-menu.

In addition, a spectrum analysis must be performed to ensure that no spurious emissions are generated due to internal or external reasons (e.g., inverse intermodulation in the final stage).

If the reflected power exceeds 10% of the direct power, you will not be able to increase the output power beyond a certain value due to an excessive SWR (standing wave ratio). Where this occurs, the antenna system must be checked with a view to minimizing the reflected power.

If the red ALARM indicator light appears, this means that an alarm event has occurred. When this happens, check the type of alarm on the display, refer to the error table, and resolve the problem.

*While in normal operation, we recommend that you leave your device on the **STATUS** sub-menu, found under the main **VIEW** menu.*

*If you leave the device in the main **SETUP** menu, after a period, the timer will automatically select the **STATUS** sub-menu under the main **VIEW** menu in order to avoid programming accidental settings.*

2.2.10 Changing from full operation to stand-by and vice-versa

During normal operation, you can place the transmitter in stand-by by pressing the **ON/STAND-BY** button. The device is on stand-by when the **ON** LED changes from green to yellow.

To perform the reverse operation, press the **ON/STAND-BY** button again. The **ON** LED will light up in green.

2.2.11 Turning off the transmitter

To completely deactivate the device (for maintenance, etc.), we recommend that you first put it on stand-by, as described above, and then completely turn off the device via the general power switch.

2.3 Menu and Navigation Commands.

To view the device's operating parameters, and to set parameters according to your requirements, you will need to navigate the commands menu shown on the LCD display. You can navigate the menu using:

- The multi-function knob.
- The **ESCAPE** button.

2.3.1 Multifunction knob

The multifunction knob is used to select the various menus that allow you to view or set the device's parameters and functions. It can be used in a variety of ways:

- **When turned clockwise**, it shows the next menu (or next option).



- **When turned anti-clockwise**, it shows the previous menu (or previous option).

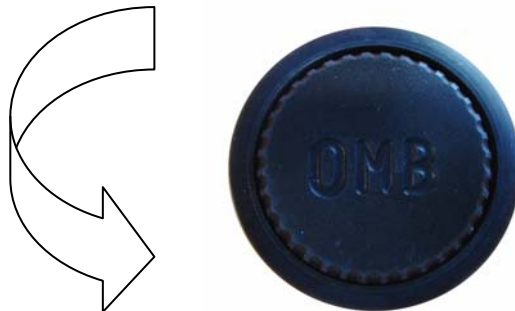

- **When pressed briefly like a button**, it allows the user to access the menu currently highlighted (or option currently highlighted).

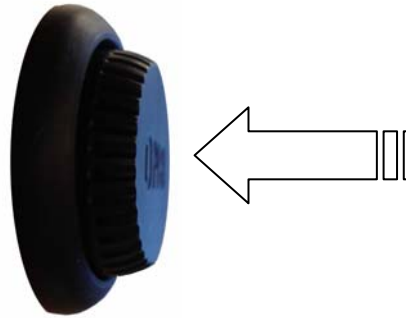

You can also turn the knob clockwise and anti-clockwise to select the various screens showing data that can be viewed within a menu. For example, alarm events in the view alarms menu.

2.3.2 ESCAPE button

The **ESCAPE** button allows you to return to the previous menu level. As such, repeatedly pressing this button returns you to the main screen (you usually only need to press it twice), which appears when you turn the device on.

2.3.3 Navigating the commands menu

Generally, you can navigate the commands menu as follows:

- 1) From the main screen (which appears when you turn the device on), turn the knob until one of the two main menus, **VIEW** or **SETUP**, are highlighted.
- 2) Briefly press the knob to access the highlighted menu. The first page of the selected menu will appear (in the example below, the first page of the **SETUP** menu).



- 3) Turn the knob to select the desired sub-menu, then confirm by briefly pressing the knob. In the example below, the screen for the **FREQUENCY** sub-menu is shown.



4) At this point, depending on the main menu that you have accessed, various options may be available. Each option is explained in detail in the following chapter, and a brief overview is provided below:

VIEW menu – used to check the device’s operating parameters and alarms/events; as such, options are not usually available in its sub-menus. Once you have accessed a sub-menu, turning the knob has no effect, with the exception of the **MPX GRAPH** and **VIEW LOG** sub-menus.

SETUP menu – this was expressly designed to set the transmitter’s parameters; as such, the options **EDIT**, **ABORT**, and **OK** are available in all the sub-menus.

5) Where required, use the knob according to the instructions provided in each of the following descriptions of the individual sub-menus.

6) To go back to the previous level (and exit the current menu/sub-menu), press the **ESCAPE** button.

7) Where necessary, repeat the previous step multiple times until you return to the main screen, indicated in step 1.

*Access to the **VIEW** and/or **SETUP** menus may be password protected. If so, you may need to enter a previously assigned password at step 2.*

2.3.4 Additional commands in the SETUP and VIEW menus

- NEXT PAGE and PREV PAGE

The **SETUP** and **VIEW** menus are composed of multiple pages; as such, you can access the next page by selecting the **NEXT PAGE** sub-menu, and the previous page by selecting **PREV. PAGE**.

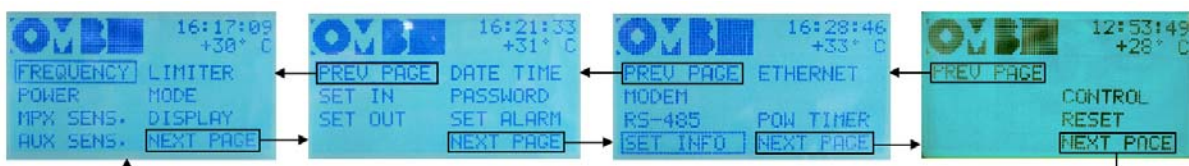

SETUP MENU

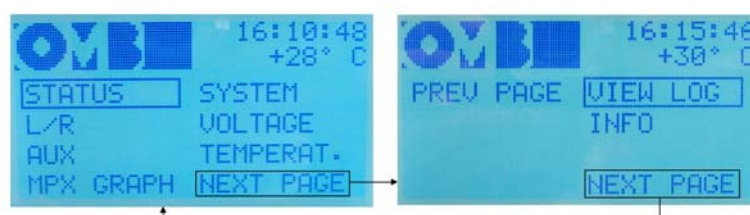

VIEW MENU

- EDIT, ABORT, and ESCAPE

Once you've entered one of the sub-menus in the **SETUP** menu, turning the knob allows you to select three commands that appear at the bottom of the screen:

- **EDIT** - used to access a setting and modify parameters.
- **ABORT** – used in the same manner as pressing the **ESCAPE** button, and thus to exit the screen and return to the previous navigation level without saving any settings made in that sub-menu.
- **OK** – confirms settings made in a sub-menu.

2.4 Description of the menu.

2.4.1 Default screen

As soon as the device is turned on, the default screen will appear on the display, indicating the following information:

- **Model:** indicates the transmitter model.
- **Version:** indicates the software version installed.



The following main menu can be selected from the bottom part of the screen:

- **VIEW:** used to view the transmitter's operating parameters.
- **SETUP:** used to set operating parameters and many of the device's functions/services.

*The main **VIEW** menu is normally the menu accessed; as such, pressing the knob will take you to that menu. For further details, refer to the next section.*

*Access to the **VIEW** and **SETUP** menus may be password protected. If so, you will be asked for the previously assigned password. The menu and sub-menu screens described below all indicate the current time and temperature in the top right corner.*

In order to avoid misinterpreting the screens, it is important to verify the exact model number of your device on the main menu, and to safely store this model number.

2.4.2 VIEW menu

This menu is used to view the transmitter's operating parameters; for example, direct power, reflected power, modulation, etc. It is in turn organized into nine sub-menus divided into the following two pages:

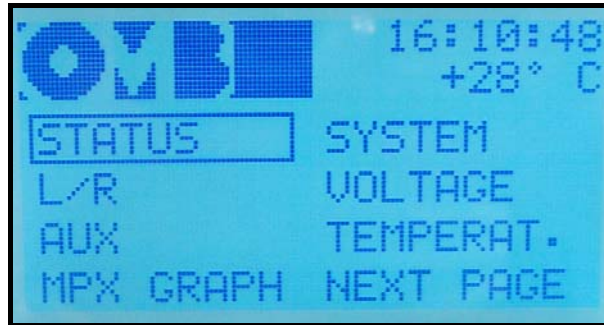

VIEW Page 1



VIEW Page 2

- **STATUS** – indicates the primary measurements, such as direct power, reflected power, etc.
- **L/R** – for measuring modulation.
- **AUX** – for measuring modulation of the auxiliary RDS/SCA signal.
- **MPX GRAPH** – graphically displays modulation in various modes.
- **SYSTEM** – indicates the main system parameters, such as frequency, mono/stereo mode, pre-emphasis, etc.
- **VOLTAGE** – measures internal power voltages.
- **TEMPERAT.** – measures internal temperatures.
- **VIEW LOG** – indicates alarms/events that have occurred during operation.

*During normal use of the device, we recommend that the **STATUS** menu be selected.*

*Each of the above sub-menus is used to view parameters; as such, options cannot be selected using the knob, with the exception of the **MPX GRAPH** and **VIEW LOG** sub-menus.*

- **INFO** – indicates if the stereo, modem and Ethernet options are present in the equipment or not.

- STATUS sub-menu

The screen for this sub-menu contains the following items:

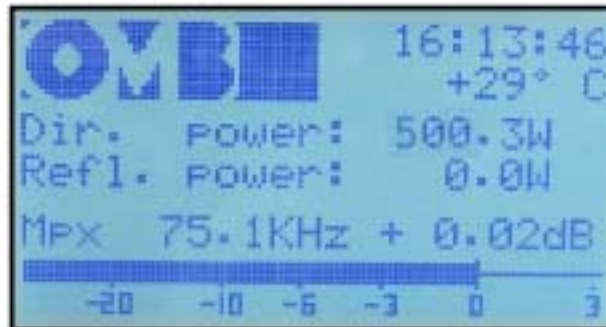

- **Dir. Power:** indicates the direct power currently delivered (in the example, 100.3 W).
- **Refl. Power:** indicates the reflected power currently measured (in the example, 0.0 W).
- **Mpx** (multiplex) – indicates the peak deviation, expressed in KHz (in the example, 75.1 KHz) and 0.02dB, in reference to a deviation of 75 KHz (0dB = 75 KHz). To change the deviation in function of the modulating signal, the modulation sensitivity must be set via the **MPX SENS** submenu, from the main **SETUP** menu.

In addition, the bar indicator graphically shows the last parameter indicated.

This screen shows the most important parameters; as such, it is normally the one displayed during normal use of the transmitter.

*In order to avoid saving accidental settings, when the **SETUP** has been accessed but no operation performed within a certain period of time, the device will automatically exit the **SETUP** menu and enter the **VIEW** menu, selecting the sub-menu **STATUS**.*

*To adjust the output power, go to the sub-menu **POWER** under the **SETUP** menu.*

- L/R sub-menu

The screen for this sub-menu is used to monitor total peak modulation. It shows the following items:



- **Left** (left channel) – the current level of the left modulating signal, expressed in dB, against the nominal level (in the example, +0.08 dB).

- **Right** (right channel) – the current level of the right modulating signal, expressed in dB, against the nominal level (in the example, +0.15 dB).

In addition, the bar indicators graphically show the two parameters indicated above (peak value).

Depending on the setting made in the **SETUP** menu, the modulation level can also be viewed via this screen, which indicates a solo or a multiplex channel (which share the same channel).

*Adjustments can be made to the nominal modulation level via the **SETUP** menu.*

- **AUX** sub-menu

The screen for this sub-menu shows the modulation level for the **Aux** RDS/SCA signal:

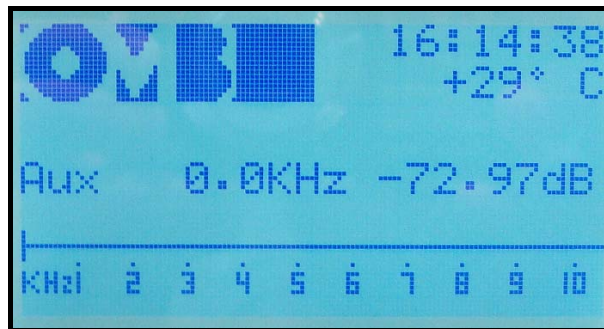

The above example shows the standard level of the RDS signal (0 KHz), as well as the bar indicator, which shows the level graphically.

*Adjustments can be made to modulation of the auxiliary signal via the **SETUP** menu.*

- **MPX GRAPH** sub-menu

This sub-menu graphically shows the modulation trend over time in three different scales indicated on the right. The different scales can be selected by simply turning the knob.

The first (**LAST 2 Min.**) shows the modulation trend for the last two minutes. The second (**LAST 2 Hr.**) shows the modulation trend for the last two hours. The third (**LAST 24 Hr.**) shows the modulation trend for the last 24 hours.

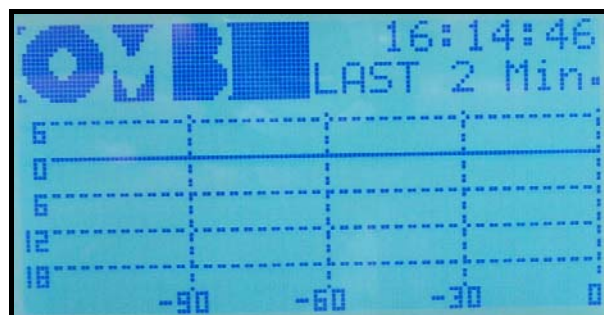

The screens are shown cyclically. As such, at the third screen, turning the knob clockwise will take you back to the first screen.

Similarly, if you are at the first screen and you turn the knob anti-clockwise, the last screen will be selected.

- SYSTEM sub-menu

The screen for this sub-menu shows the key parameters (set frequency, mono/stereo mode, etc.) as follows:

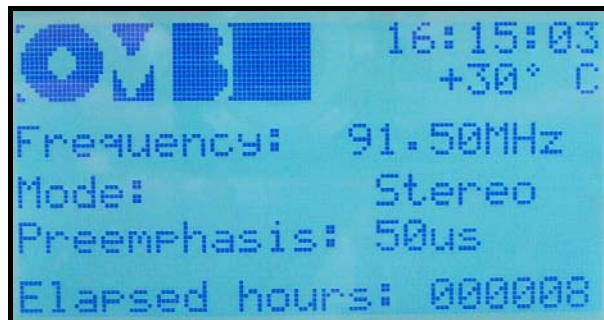

- **Frequency:** indicates the operating frequency (in the example, 91.50 MHz).
- **Mode:** indicates **Mono**, **Stereo**, **Mono L+R**, or **Mpx** mode (in the example, **Stereo**).
- **Preemphasis:** indicates the modulation preemphasis value (in the example, 50 microseconds).
- **Elapsed hours:** indicates the time elapsed since the device was first turned on in the factory (in the example, 8 hour).

*These adjustments are available via the **SETUP** menu.*

- VOLTAGE sub-menu

The screen for this sub-menu indicates the device's power voltages as follows:



- **Vsupply+** (positive voltage supply) – indicates the positive voltage supply for the low power section (in the example, +12.43V)
- **Vsupply-** (negative voltage supply) – indicates the negative voltage supply for the low power section (in the example, -11.85V)
- **Vsupply2+** (positive voltage 2) – indicates the voltage supply for the power section (in the example, +48.22V)
- **GSM Batt** (GSM battery voltage supply) – indicates the voltage for the battery that powers the optional remote control unit via GSM cellular phone (in the example, **NP** indicates that the optional module is not present)

- TEMPERAT. sub-menu

The screen for this sub-menu indicates the current operating temperatures as follows:



- **CPU temp.** – indicates the current CPU temperature (in the example, +30 °C)
- **RF temp.** – indicates the RF temperature, if pertinent to the model in use (in the example, +35 °C)

- VIEW LOG sub-menu

This sub-menu provides a historical record of events (transmitter turned on, turned off, on stand-by, etc.) and alarms (insufficient modulation, excessive reflected power, etc.) that took place during operation. The transmitter's memory (non volatile) can record up to 100 alarms/events. As soon as you enter this menu, the transmitter takes a few seconds to update the data; during this time, the screen **waiting...** appears.

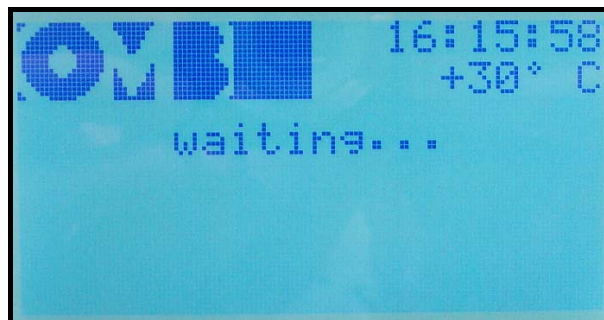

Next, the following screen will appear:



If the device already has 100 events/alarms in its memory, a new event/alarm that occurs will cancel out the oldest recording so that the new event/alarm can be saved (FIFO).

Via the **SETUP** menu, you can decide whether to activate/deactivate each alarm (e.g., low power, insufficient modulation, etc.), and set new detection thresholds. Through this menu, you can also delete the alarm history.

If an alarm event occurs when you are accessing the **VIEW LOG** menu, you must exit and re-enter the **VIEW LOG** menu in order to view the alarm on the event list.

To select subsequent alarm events (less recent, with higher numbers), turn the knob anti-clockwise; turning the knob clockwise will take you to the most recent events.

- IN FO sub-menu

This sub-menu provides information about the presence of the different options the equipment may have or not present.

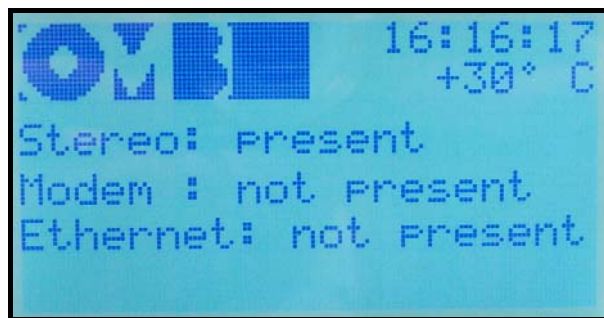

In the example only the Stereo option is present, and the Modem and Ethernet options are not.

2.4.3 SETUP menu

This menu allows you to program the device's operating parameters; for example, operating frequency, output power, modulation, passwords, etc. It is divided into the following four pages:



SETUP Page 1



SETUP Page 2



SETUP Page 3



SETUP Page 4

To move from one page to another, select the commands **NEXT PAGE** or **PREV PAGE** using the knob, then press to confirm.

As you can see, the four pages allow you to access the following settings:

- **FREQUENCY** – frequency increment steps and operating frequency
- **POWER** – output power level
- **MPX SENS** – modulation sensitivity
- **AUX SENS** – auxiliary modulation sensitivity, e.g., RDS
- **LIMITER** – maximum deviation limiter
- **MODE** – transmission mode, e.g., stereo/mono and pre-emphasis
- **DISPLAY** – display backlighting and contrast
- **SET IN** – logic levels for the ENABLE line and related activation mode
- **SET OUT** – logic levels for remote control

- **DATE TIME** – system date and time
- **PASSWORD** – set passwords
- **SET ALARM** – alarm identification mode
- **ETHERNET** – Ethernet LAN interface settings
- **RS-485** – RS485 interface settings
- **POW TIMER** – set automatic power reduction during specific time periods
- **MODEM** – modem modes
- **CONTROL** – control modes
- **RESET** – modem reset

- **FREQUENCY setting**

Used to define the transmitter's operating frequency.



The following parameters can be set:

- **Step** – frequency increments can be selected (in the example, 100 KHz)
- **Frequency** – operating frequency

- **POWER setting**

Used to adjust the transmitter's output power.



The display shows the following:

- **Pow. set** – set power
- **Pow. out** – measurement of the power supplied

- MPX SENS setting

Used to adjust modulation input sensitivity according to the low frequency level available.



The display shows the following:

- **Mpx** – followed by the deviation value, expressed in KHz (in the example, 75.1 KHz) and in dB, in reference to a deviation of 75 KHz (0dB = 75 KHz)
- **Nom. input** – nominal value of low frequency input level (in the example, + 0.0 dBm)

- AUX SENS (RDS/SCA sensitivity modulation) setting

Used to adjust the present modulation result of the single auxiliary signal (RDS/SCA).



The display shows the following:

- **Aux** – followed by a deviation value expressed in KHz (in the example, 0.0 KHz) and in dB, in reference to a deviation of 75 KHz (0dB = 75 KHz)
- **Nom. input** – nominal value of auxiliary signal input level

To change the auxiliary modulation:

- 1) Ensure that the **EDIT** option is selected; otherwise, turn the knob to select it, then press to confirm.
- 2) A value will be indicated after **Nom. input**. This indicator is normally predefined at **+0.0 dBm**.

- 3) Turn the knob to change the value, based on the modulation level used. The peak deviation indicated by **Aux**, expressed in KHz, will consequently change. You will note that, to the right of the deviation, the value of the modulating signal will be indicated in dB, against the nominal value set.
- 4) Ensure that the deviation measured does not exceed local regulations, then press the knob to confirm the setting.
- 5) Using the knob, select **OK** to save the settings, **EDIT** to make further changes, or **ABORT** to exit without saving the new settings, then press to confirm

- LIMITER setting

Used to limit the peak modulation at a maximum value.



The display shows the following:

- **Limiter** – followed by **OFF** if deactivated, or by a value expressed in dB, in reference to a deviation of 75 KHz (0dB = 75 KHz)
- **Mpx** – measurement of the current peak deviation value, expressed in KHz (in the example, 74.8 KHz) in dB, in reference to a deviation of 75 KHz (0dB = 75 KHz)

In addition, the bar indicator graphically shows the current peak deviation value.

By changing the **Limiter**, you can set a maximum modulation value beyond which the limiter will activate.

When the limiter begins to intervene, the modulation distortion increases. As such, the modulation sensitivity should be adjusted so the limiter intervenes sporadically. Using this approach, its operation is generally imperceptible.

- MODE setting

Used to define whether the transmitter operates in mono or stereo, and its pre-emphasis value.

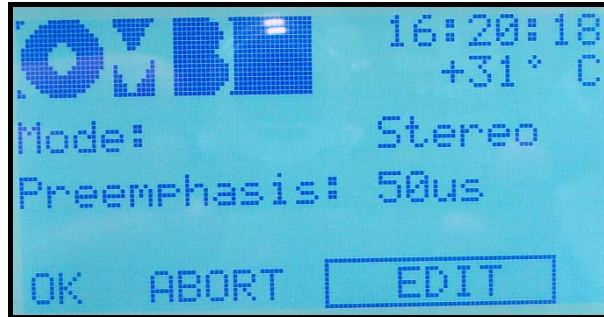

The display shows the following:

- **Mode** – followed by **Mono** (from the **RIGHT** input, **Stereo**, **Mono L+R** (monophony obtained through the sum of the stereo channels), or **Mpx** (external multiplex modulation signal originating from the **MPX** input).
- **Pre-emphasis** – followed by the current pre-emphasis value, expressed in microseconds.

To change the auxiliary modulation:

- 1) Ensure that the **EDIT** option is selected; otherwise, turn the knob to select it, then press to confirm. A value will be indicated after **Mode**.
- 2) Turn the knob to change the setting to **Mono**, **Stereo**, **Mono L+R**, or **Mpx** according to your requirements, then press the knob. A value will be indicated after **Preemphasis**.
- 3) Turn the knob to change the setting to **0**, **25**, **50**, or **75** microseconds, according to your requirements (50 microseconds for Spain), then press the knob to set the value.
- 4) Using the knob, select **OK** to save the settings, **EDIT** to make further changes, or **ABORT** to exit without saving the new settings, then press to confirm.

- DISPLAY setting

Used to optimize display legibility, based on ambient lighting conditions and the angle of the visual field.



This screen shows:

- **Backlight** – followed by the current backlighting value
- **Contrast** – followed by the current contrast value

To change these parameters:

- 1) Ensure that the **EDIT** option is selected; otherwise, turn the knob to select it, then press to confirm. A value will be indicated after **Backlight**.
- 2) Turn the knob to change the backlighting, which will immediately change based on the setting selected (three levels are available; 3 corresponds to maximum illumination), then press to confirm. A value will be indicated after **Contrast**.
- 3) Turn the knob to change the contrast, which will immediately change based on the setting selected (twenty levels are available; 1 corresponds to maximum contrast), then press the knob to set the value.
- 4) Using the knob, select **OK** to save the settings, **EDIT** to make further changes, or **ABORT** to exit without saving the new settings, then press to confirm.

- SET IN (remote control input) setting

Used to set logic levels for the ENABLE line in the remote control input:

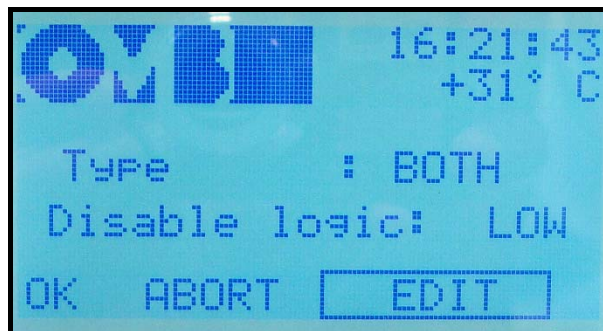

The following parameters can be adjusted:

- **Type** – transmitter's activation/deactivation mode. You can define whether this takes place via the front ON/STAND-BY button only (the ENABLE line is therefore deactivated), the rear line only (the front ON/STAND-BY button is deactivated), or using both commands (either the front button or the ENABLE line). To this end, the settings **BOTH**, **LOCAL**, and **REMOTE** (only via the ENABLE line) are available.
- **Disable logic**: - defines whether activation of the command takes place using a LOW or HIGH logic level. The device is normally deactivated with a low level, meaning when this line is grounded.

To set these parameters:

- 1) Ensure that the **EDIT** option is selected; otherwise, turn the knob to select it, then press to confirm. A value will be indicated after **Type**.
- 2) Turn the knob to change the setting to **BOTH**, **LOCAL**, or **REMOTE** according to your requirements, then press the knob to set the value. A value will be indicated after **Disable logic**.
- 3) Turn the knob to change the setting to **LOW** or **HIGH** according to your requirements, then press the knob to set the value.
- 4) Using the knob, select **OK** to save the settings, **EDIT** to make further changes, or **ABORT** to exit without saving the new settings, then press to confirm

The ENABLE line is equipped with an internal pull-up resistance that maintains the line on high status in the absence of a signal or connection.

If **BOTH** is set under **Type** and the **ENABLE** line on the rear input is short-circuited, the **ON/STAND-BY** button won't work correct when this setting performs a logic function (**OR**) for the two commands.

- SET OUT (remote control output) setting

This screen allows you to define the logic levels (high/low) used for remote control:

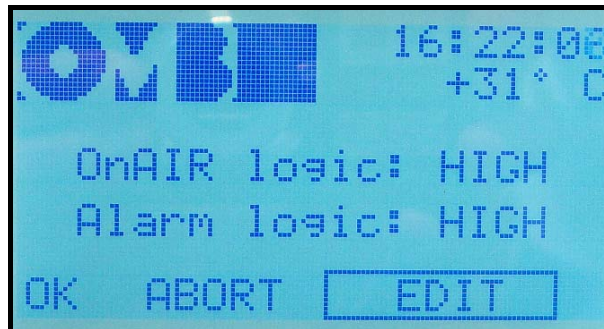

You can define whether the status of the following lines normally has a HIGH or LOW logic level:

- **OnAIR logic** – ON THE AIR line, which signals when the device is powered up
- **Alarm logic** – ALARM line, which signals the presence of an alarm

To set these parameters:

- 1) Ensure that the **EDIT** option is selected; otherwise, turn the knob to select it, then press to confirm. A value will be indicated after **OnAIR logic**.
- 2) Turn the knob to change the setting to **LOW** or **HIGH** according to your requirements, then press the knob to set the value. A value will be indicated after **Alarm logic**.
- 3) Turn the knob to change the setting to **LOW** or **HIGH** according to your requirements, then press the knob to set the value.
- 4) Using the knob, select **OK** to save the settings, **EDIT** to make further changes, or **ABORT** to exit without saving the new settings, then press to confirm

The alarm activation threshold levels can also be defined via the alarm menu

- DATE TIME setting

Used to set the date and time used by the system to generate an alarm history, and for other functions.

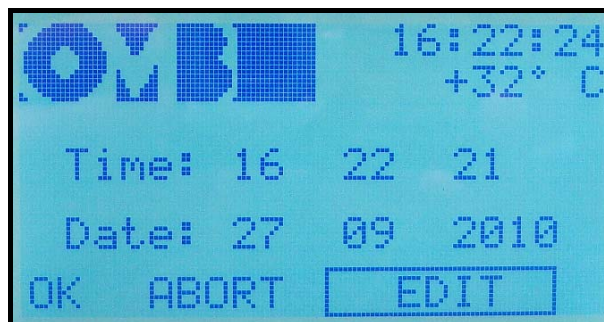

The display shows the following:

- **Time** – followed by the currently set time
- **Date** – followed by the currently set date

It is important to correctly set the time and date; otherwise, the alarm history and various other functions will not operate correctly.

- PASSWORD (menu protection) setting

Used to activate and set the passwords to protect access to the menus. Two passwords are available:

- **LEV 1** – this level is more restrictive, and protects access to both the **VIEW** and the **SETUP** main menus.
- **LEV 2** – protects access to the **SETUP** menu only.

Each password is composed of four alphanumeric characters (numbers **0-9** or letters **A-Z**).

*Activate only one of the two passwords (**LEV 1** or **LEV 2**) according to your requirements. Activating both passwords may cause problems when using the transmitter.*

If one of the two passwords is activated, remember to store it in a safe location. Losing a password requires that the level 3 password be used; this password should never normally be used.

The display shows the following:



- **SET PASSWORD LEV 1**
- **SET PASSWORD LEV 2**

• In order to gain confidence with the password settings menu and with its operation, we recommend that the password be set as **0 0 0 0** (four zeros) the first time.

LEVEL 1 PASSWORD

To protect both main menus, activate/set the **LEV 1** password as follows:

- 1) Select **SET PASSWORD LEV 1** with the knob, then press to confirm.
- 2) Using the knob, select **EDIT** and press to confirm. **OFF** (password deactivated) will be selected. Turn the knob to select **ON**, then press to confirm. The first character in the password will be highlighted.
- 3) Turn the knob to select the first character, then press to confirm. The second character in the password will be highlighted.
- 4) Turn the knob to select the second character, then press to confirm. The third character in the password will be highlighted.

- 5) Turn the knob to select the third character, then press to confirm. The fourth character in the password will be highlighted.
- 6) Turn the knob to select the fourth character, then press to confirm. The first character in the **Confirm** line will be highlighted; repeat the same password on this line in order avoid errors in setting the password.
- 7) Set the four characters on the **Confirm** line as explained in steps 3) to 6).
- 8) Using the knob, select **OK** to save the settings, **EDIT** to make further changes, or **ABORT** to exit without saving the new settings, then press the knob to confirm.
- 9) Store the password in a safe place.

*If the four characters in the **CONFIRM** line do not correspond to the ones entered in the first line, a **Wrong password** message will appear. Press the knob to delete the screen and return to step 2).*

Once a level 1 password is activated, each time someone attempts to access the **SETUP** menu, they will receive an **Insert PASSWORD** message asking for the password to be entered. Access to the **VIEW** menu is timed, and the password will only be requested if the **VIEW** menu is not used for a given period of time.

LEVEL 2 PASSWORD

If you wish to protect the **SETUP** menu only, activate/set the **LEV 2** password using the same procedure as outlined above, ensuring that **SET PASSWORD LEV 2** is selected at step 1).

Once a level 2 password is activated, each time someone attempts to access the **SETUP** menu, they will receive an **Insert PASSWORD** message asking for the level 2 password to be entered. The **VIEW** menu will remain accessible at all times.

- SET ALARM setting

As previously explained, if a parameter falls outside a given value for a specific period of time (for example: modulation 6 dB lower than the nominal value for more than 10 minutes), the **ON** LED will light up in red and the bottom part of the display will indicate the associated alarm (e.g., **Mpx Low** = insufficient modulation). The last 100 alarm events can be accessed via the **VIEW LOG** alarm history menu, under the main **VIEW** menu.

This menu allows you to activate/deactivate each diagnostic alarm, and to set its sensitivity level and the time period beyond which the alarm is activated. In addition, the **RESET LOG** function is available, which allows you to delete the alarm history saved.



The following alarms can be set:

- **LOW RF POW** – an alarm is issued when the RF power is detected at below a certain percentage value.
- **HIGH VSWR** – an alarm is issued when an excessive SWR (standing wave ratio) is detected.
- **UNLOCK** – an alarm is issued when the internal PLL frequency synthesizer is unlocked.
- **MPX** – an alarm is issued when low (or no) modulation is detected for a given period of time.

In general, to set alarms:

- 1) Turn the knob to select the alarm that you wish to activate/configure (e.g., **LOW RF POW**), then press to confirm.
- 2) Ensure that the **EDIT** option is selected; otherwise, turn the knob to select it, then press to confirm. The first value to be set will be highlighted.
- 3) Turn the knob to change the setting according to your requirements, then press to set.
- 4) If the setting includes this option, the second alarm setting will be highlighted. Turn the knob to change the setting according to your requirements, then press to set.
- 5) Using the knob, select **OK** to save the settings, **EDIT** to make further changes, or **ABORT** to exit without saving the new settings, then press the knob to confirm.

LOW RF POW

Two parameters can be set from this screen:



- **PreAl. Low Power** – if the output power falls below the percentage set here, a warning pre-alarm is issued by flashing the **ALARM** LED. The pre-alarm is not saved in the event history.
- **Alarm Low Power** – if the output power falls below the percentage set here, an alarm is issued via a steadily lit **ALARM** LED. Obviously, this alarm is saved in the event history.

To set the low power pre-alarm and alarm:

- 1) Ensure that the **EDIT** option is selected; otherwise, turn the knob to select it, then press to confirm. A value will be indicated after **PreAl.Low Power**.
- 2) Turn the knob to change the percentage to meet your requirements, then press to confirm. A value will be indicated after **Alarm Low Power**.
- 3) Turn the knob to change the percentage to meet your requirements, then press to confirm.
- 4) Using the knob, select **OK** to save the settings, **EDIT** to make further changes, or **ABORT** to exit without saving the new settings, then press to confirm.

HIGH VSWR

From this screen, a value can be set for reflected power, beyond which a high SWR alarm will be issued.



In the above example, the **Ref1. Power alarm** is issued when a reflected power of 20.0 W is exceeded.

To set the high reflected power alarm:

- 1) Ensure that the **EDIT** option is selected; otherwise, turn the knob to select it, then press to confirm. A value will be indicated after **Ref1. Power alarm**.
- 2) Turn the knob to change the reflected power level according to your requirements, then press to confirm.
- 3) Using the knob, select **OK** to save the settings, **EDIT** to make further changes, or **ABORT** to exit without saving the new settings, then press to confirm.

UNLOCK

From this screen, a time can be set, beyond which an alarm will be issued if the transmitter's internal synthesizer continues to be unlocked.

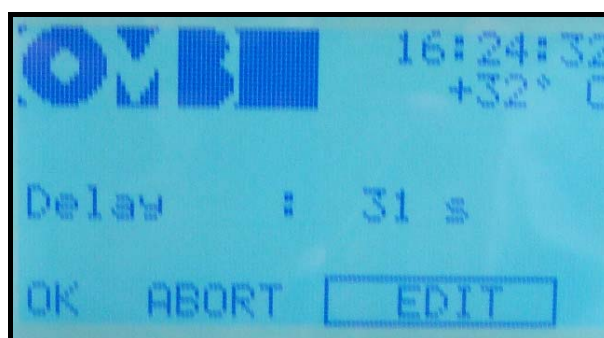

In the above example, if the synthesizer is unlocked for a **Delay** of 31 seconds, an alarm will be issued.

To set the synthesizer unlock alarm:

- 1) Ensure that the **EDIT** option is selected; otherwise, turn the knob to select it, then press to confirm. A value will be indicated after **Delay**.
- 2) Turn the knob to change the time according to your requirements, then press to confirm.

3) Using the knob, select **OK** to save the settings, **EDIT** to make further changes, or **ABORT** to exit without saving the new settings, then press to confirm

MPX

From this screen, you can personalize the insufficient modulation alarm. Two parameters can be set:



- **Mpx Alarm** – the threshold below which modulation, expressed in dB in reference to a deviation of 75 KHz (0dB = 75 KHz), is considered insufficient.

- **Delay** – the time in seconds after which, if modulation remains insufficient, an alarm is issued.

In the above example, the alarm is issued only when modulation constantly remains at least 16 dB below 75 KHz for 56 seconds.

To set the insufficient modulation pre-alarm and alarm:

1) Ensure that the **EDIT** option is selected; otherwise, turn the knob to select it, then press to confirm. A value will be indicated after **Mpx Alarm**.

2) Turn the knob to change the modulation to a level that is considered insufficient for your requirements, then press to confirm.

A value will be indicated after **Delay**.

3) Turn the knob to change the time interval according to your requirements, then press to confirm.

4) Using the knob, select **OK** to save the settings, **EDIT** to make further changes, or **ABORT** to exit without saving the new settings, then press to confirm.

RESET LOG

As previously mentioned, this menu does not allow you to configure alarms, but rather to delete the alarm history.

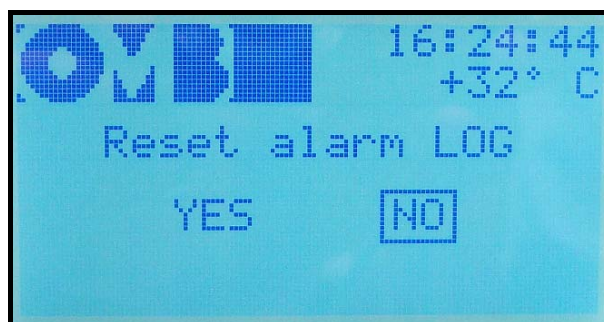

When you access this menu, two simple commands are available by turning the knob:

- **YES** – the alarm history will be deleted. The message **waiting...** will appear while the history is being deleted.
- **NO** – the alarm history will not be deleted (in cases of accidental access to the sub-menu, where there is no actual need to delete the history).

After either command is selected, the display will return to the **SET ALARM** sub-menu.

The alarm/event history delete function does not request confirmation; as such, be careful not to accidentally delete the history.

- POW TIMER setting

Used to automatically decrease the transmitter's power by a given percentage during a specific time period (e.g., night time).

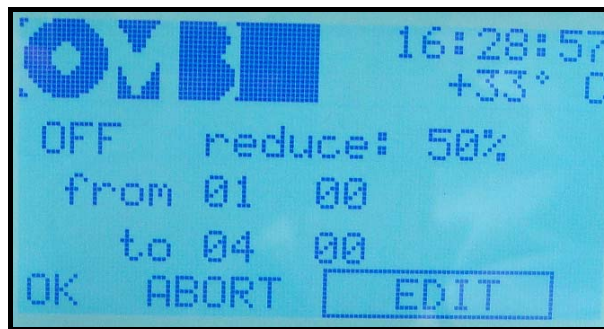

The display shows the following parameters:

- **OFF** or **ON** – power reduction deactivated (OFF) or activated (ON).
- **Reduce**: percentage of power reduction compared to the power set via the menu.
- **From** – followed by two sets of numbers (hour and minute). Indicates the time in which the transmitter will reduce power.
- **To** – followed by two sets of numbers (hour and minute). Indicates the time in which the transmitter will return to the normal power level set via the menu.

To set automatic power reduction:

- 1) Ensure that the **EDIT** option is selected; otherwise, turn the knob to select it, then press to confirm. A value will be displayed after **OFF** or **ON**.
- 2) Turn the knob to set **OFF** or **ON** according to your requirements, then press to confirm. A value will be indicated after **reduce**.
- 3) Turn the knob to change the power reduction percentage, then press to confirm. The first number (hour) will be highlighted after **from**.
- 4) Turn the knob to change the hour in which the power reduction will start (24-hour clock), then press to confirm. The second number (minutes) will be highlighted after **from**.
- 5) Turn the knob to change the minute in which the power reduction will start, then press to confirm. The first number (hour) will be indicated after **to**.

- 6) Repeat steps 4 and 5 to set the time in which the transmitter will return to normal power.
- 7) Using the knob, select **OK** to save the settings, **EDIT** to make further changes, or **ABORT** to exit without saving the new settings, then press to confirm.

- MODEM setting

If the transmitter is equipped with an optional modem, its parameters can be defined via this screen. For further details, refer to the documentation provided with this option.

*If a modem has not been installed, the screen will indicate **Modem not present**.*

- CONTROL setting

Used to select how to control the transmitter.



- 1) Ensure that the **EDIT** option is selected; otherwise, turn the knob to select it, then press to confirm. The current option will be highlighted.
- 2) Turn the knob to set Local + Remote, Local or Remote according to your requirements, then press to confirm.
- 3) Using the knob, select **OK** to save the settings, **EDIT** to make further changes, or **ABORT** to exit without saving the new settings, then press to confirm.

- Hidden menus (under level 3 password)

Beside the two level 1 and level 2 passwords, a third password, called "level 3 password" is available. It's preset during the production, it's always active and allows to access the **SETUP** sub menu and the one which allows the activation/change of the level 1 and level 2 passwords even when the user has activated and forgotten them.

There are two hidden menus which can be accessed only by entering the level 3 password. Briefly, accessing the **SETUP** menu by means of the level 3 password allows to:

- Access the **SETUP** sub menu and the one which allows the activation/change of the level 1 and level 2 passwords even when the user has activated and forgotten them.
- Change the level 3 password in order to change the one preset during the production of the equipment.

- Accessing the level 3 password

To access the **SETUP** submenu when you have forgotten the level 1 or level 2 password currently active:

- 1) Use the knob to select the **SETUP** menu and press it to confirm.
- 2) When the password is prompted, enter the level 3 password which was set during the production to **A B C D**.
- 3) Select the password change menu and change the level 1 or level 2 password which is currently active
- 4) Note down the new level 1 or level 2 password currently active and store it in a safety place.

- Changing the level 3 password

Some unauthorized people who know the level 3 password preset in the production could alter the setting of the transmitter even when it's protected with either one or both the level 1 or two passwords. For this reason you can change the level 3 password preset in the production. This operation must be done only if you are absolutely sure to note down the new level 3 password and stored it in a safety place.

IMPORTANT! Always note down the level 3 password and store it in a safety place. Should you lose it, the total reprogramming of the equipment or the CPU replacement at OMB will be mandatory – with the related costs which this operation involves. This kind of service is not included in the warranty.

To change the level 3 password :

- 1) Use the knob to select the **SETUP** menu and press it to confirm.
- 2) When the password is prompted, enter the level 3 password which was set during the production to **A B C D**.
- 3) Select the **PASSWORD** submenu. As you can see, the command **SET PASSWORD LEV 3** (set level 3 password) also appears in it
- 4) Select **SET PASSWORD LEV 3** and change the password by following the procedure stated previously.

*You can change the level 3 password, but not disable it, because its setting is always fixed to **ON**.*

2.5 Troubleshooting.

All instructions set in this manual are followed, the EM 500 DIG PLUS series will guarantee several years of perfect service. However, should problems arise, refer to this chapter before contacting the local authorized assistance point.

2.5.1 Error messages

The following table explains the meaning of the main error messages and indicates the actions to be taken in order to solve the problem.

All alarms will be usually shown in any screen you are, and they will be overlapped on the upper screen section, where you normally see the company logo, system temperature and system time. In addition, the **ALARM** LED will light.

*The messages below may appear during the amplifier normal operation as well as when the alarm data are displayed in the **VIEW LOG** sub-menu.*

- Mpx low (insufficient modulation)

The **Mpx low** alarm message appears when an insufficient modulation lasts for more than a given time. Both alarm delay and alarm threshold can be set in the alarms menu, respectively up to 180 seconds and $< -16\text{dB}$ (as to 75 KHz frequency deviation, that is $0\text{dB} = 75\text{ KHz}$).

- Refl Power High (excessive reflected power)

The **Refl Power high** alarm message appears when the reflected power level exceeds a threshold, usually set in the range from 5% to 7% of the maximum nominal power level. The threshold level can be adjusted via the alarms menu.

If necessary, the maximum reflected power level can be automatically limited to the $\sim 10\%$ of the maximum output power level reducing the direct output power.

- Over temperature

The **Over temperature** alarm may be referred to a system over temperature (CPU Temp.) or only to a RF power stage over temperature (RF temp.); each of the said temperatures is taken via a specific heat probe.

Before reaching the max allowed temperature, the alarm LED starts flashing, to signalize the approach to the limit condition. If the threshold is exceeded, the alarm LED stops flashing and starts steadily lighting. In this condition the output power level will be progressively reduced, to limit dissipation without completely blocking the transmitter operation.

To check whether the over temperature is due to whole system or to the RF power stage only, select the **Temperat.** sub-menu, in the **View** menu, which displays both the temperatures:

CPU temp. = system temperature

RF temp. = RF power stage temperature

- Unlock (unlocked PLL synthesizer)

Unlock shows an unlock status of the built in synthesizer, generally meaning a real transmitter fault. When this failure happens it's quite important to contact the local authorized assistance point.

Depending on the software release of the control firmware, this alarm is often "masked" by the consequent low RF direct output power alarm, however the **LOCK** LED keeps off whereas the **ALARM** LED steadily lights.

With the most recent software releases the **Synthesizer unlock** priority alarm will be shown in the current screen, immediately signaling such condition.

Section 3

INTERNAL MODULES

CONTENTS:

3.1 Internal modules location	58
3.1.1 Power supply.	59
3.1.2 600W FM Power Module	60
3.1.3 Low Pass Filter	63
3.1.4 Auxiliary power supply	65
3.1.5 Compada Board	66
3.2 Schematics.	67

3.1 Internal Modules Location.

Next picture shows an internal view of the EM 500 DIG PLUS transmitter:

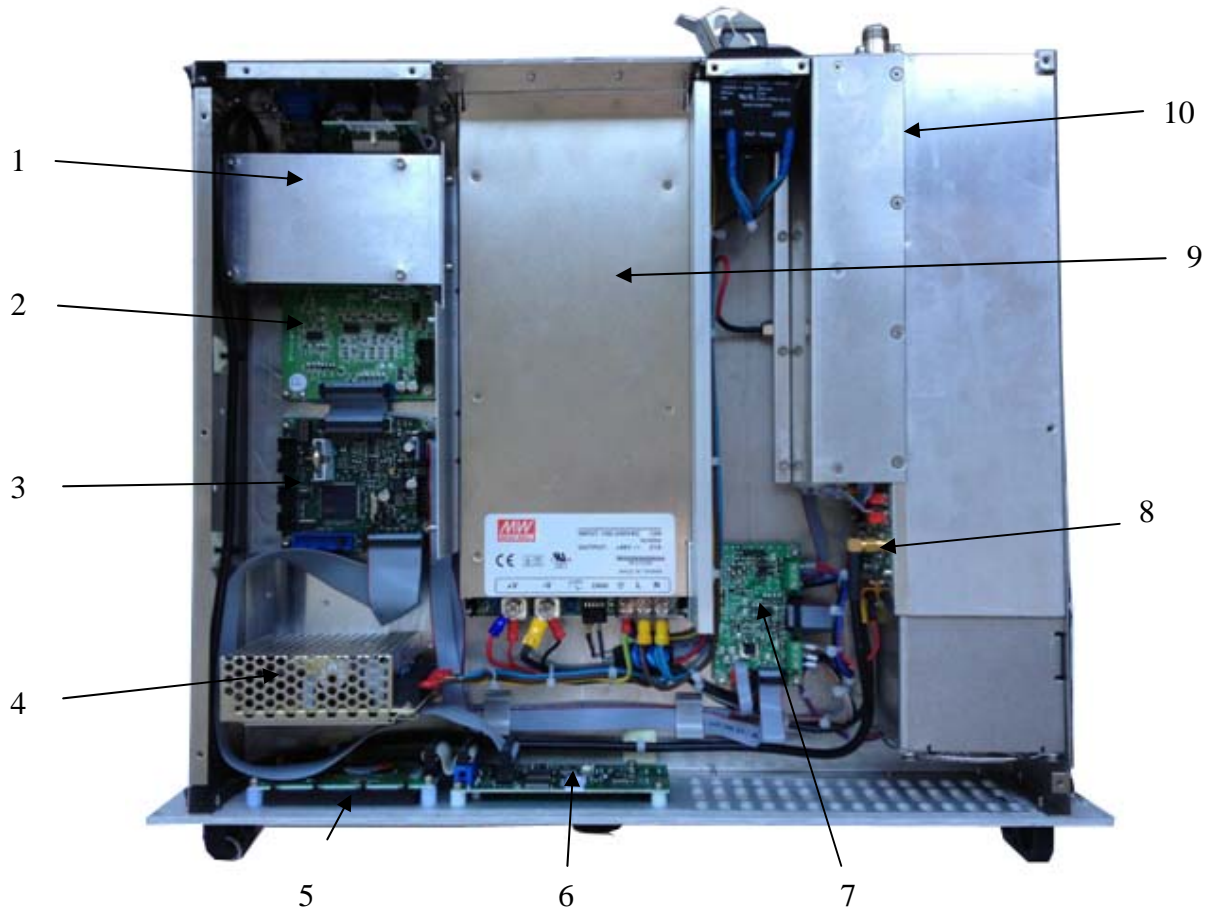

Figure 3.1: EM 500 DIG PLUS Internal View

The elements numbered in the previous picture are described next:

1. FM Synthesizer.
2. Main Board.
3. Control Unit Board.
4. Aux. Power Supply.
5. Display Board.
6. Knob Encoder Board.
7. COMPADA, Power supply control and fan speed regulator.
8. 10W Driver Module.
9. Main Power Supply.
10. Power Amplifier Block.
11. Stereo Coder (Optional).

3.1.1 Power Supply

The FMA 500 HE uses an AC/DC high performance power supply, to provide voltage to the different parts that make up the device.



Figure 3-1.. Power Supply 1000-48

These are the technical features for the power supplies we use in the Power Amplifier:

TECHNICAL SPECIFICATIONS	
Input	
Voltage	90 - 264VVAC 127-370VDC
Frequency	47-63Hz
Efficiency	90% (typical)
AC Current	12A/115VAC 6A/230VAC (typical)
Power Factor	0.95/230VAC 0.98/115VAC full load (typical)
Output	
DC Voltage	48V
Nominal Current	21A
Current Range	0 - 21A
Nominal Power	1008W
Adjustable tension Range	150mVp-p
Voltage Tolerance	43-55V
Line Regulation	±1.0%
Load Regulation	±0.5%
Alarms	
Overload	105 - 125% nominal output power
Overvoltage	56.6 - 66.2V
Overtemperature	85°C ±5°C at Diode O/P 75°C ±5°C in power transistor
General	
Working Temperature	-20 to +60°C
Storage Temperature	-40 to +85°C
Working Humidity	20-90%HR without condensation
Humidity dampness	10-95%HR without condensation
Dimensions	295x127x41mm
Weight	1.95kg

3.1.2 600W FM AMPLIFIER MODULE

The amplifier module has been developed using a capsule with two MOSFET designed for its class B *push-pull* operation. This module is able to deliver an output power of 600W. It is powered by a voltage of +48V delivered by the switching power supply of the equipment. In order to avoid any interference or the propagation of the RF signal across the rest of the equipment producing EMI radiation, the supply of these modules is made through pass-wall filters and a *choke*.

The transistors are polarized by an external BIAS Regulator, which set a fixed voltage polarization value of 8V. This voltage is then internally adjusted to the necessary value for the transistor by means of the R10 (1) adjustment.

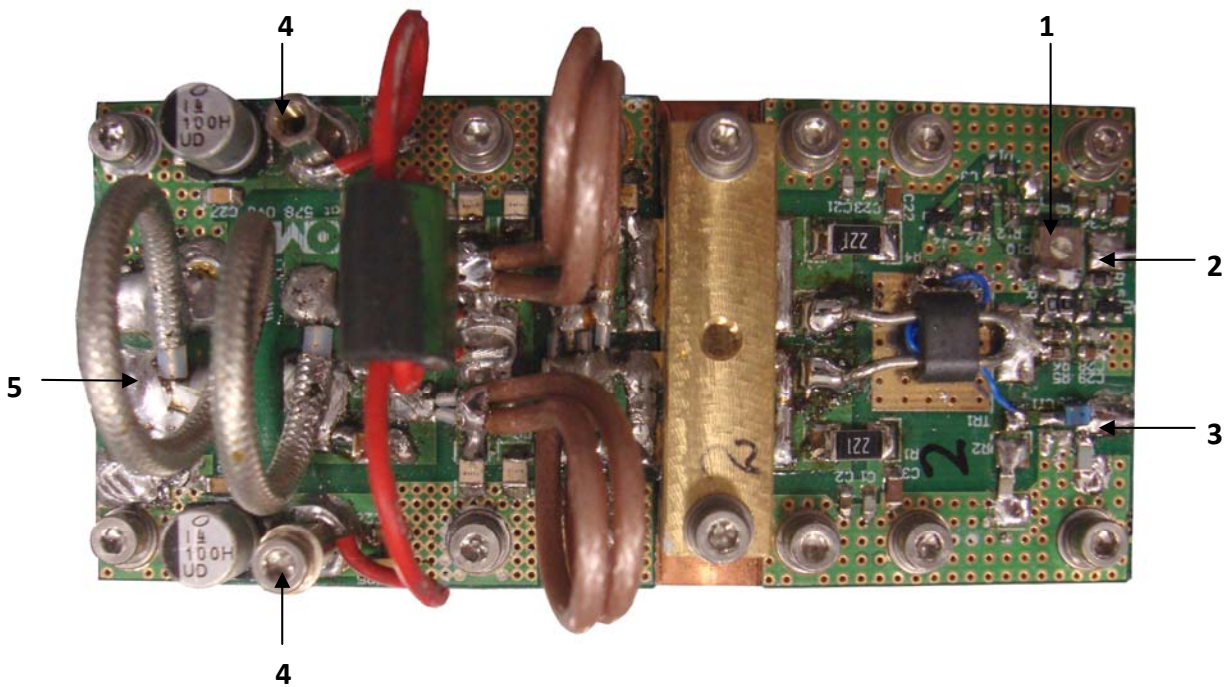
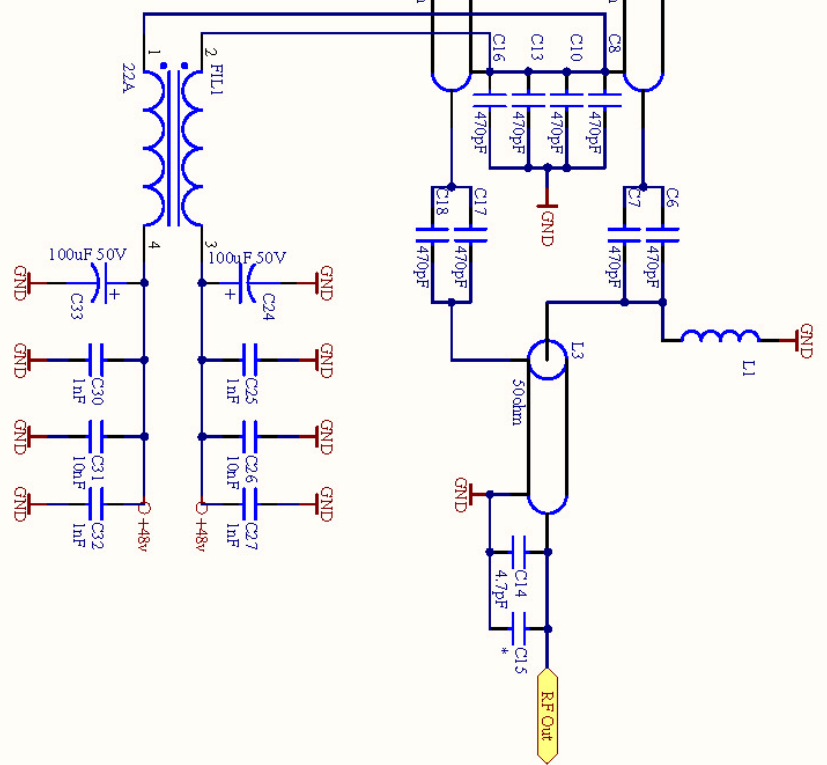
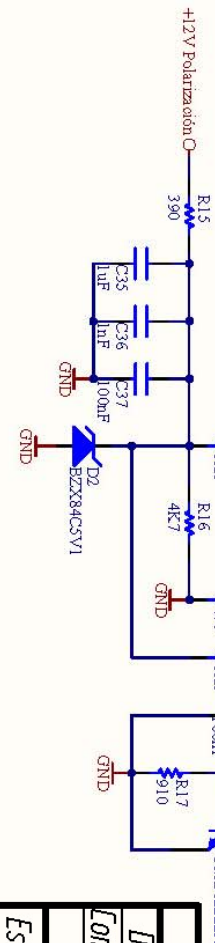
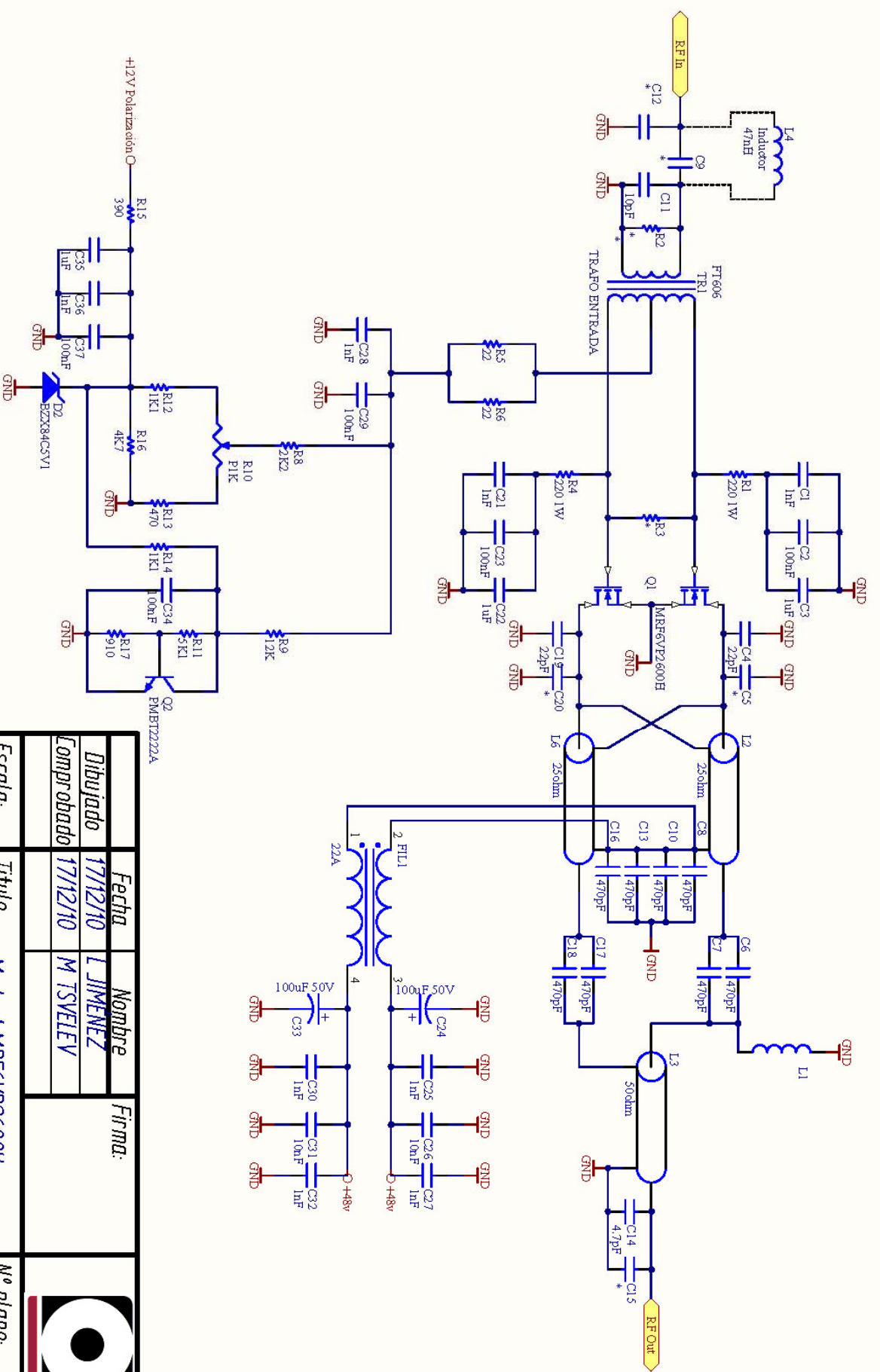

Figure 2-8: RF 600W RF Amplifier Module

Elements numbered in the previous figure are:

1. R10. Potentiometer used for the adjustment of the transistor voltage.
2. Bias connection.
3. RF Input connection.
4. VDD Supply.
5. RF Output connection.



Fecha	Nombre	Firma:
17/12/10	L JIMENEZ	
17/12/10	M TSYELEV	

Dibuñado
 Comprobado

Escala: Título
 Modpot MRF6VP2600H
Módulo Amplificador

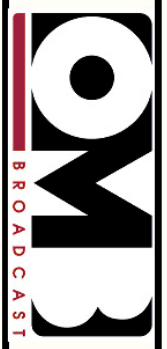

N° plano:
 35.04.02.000

Sustituye a:

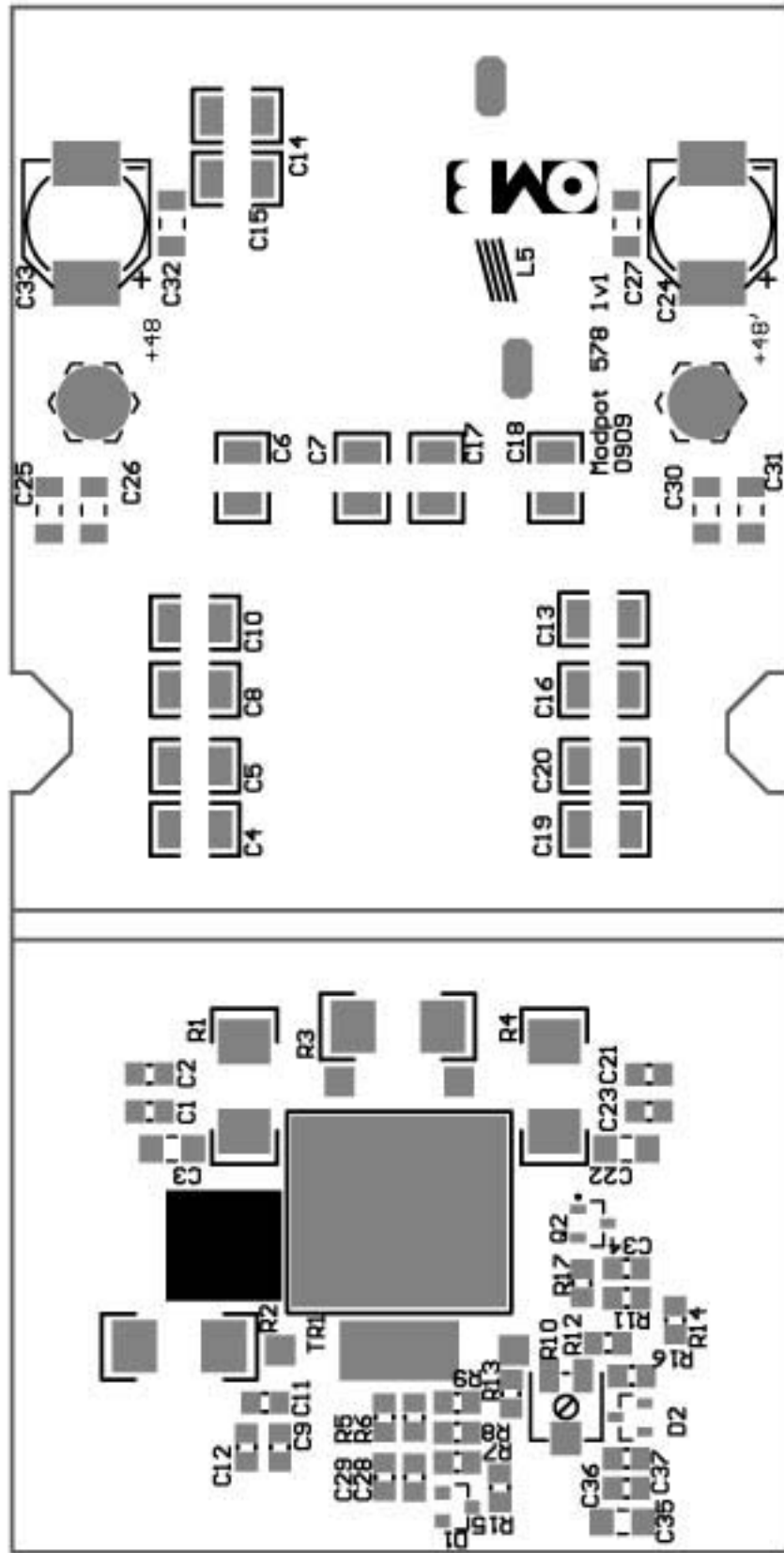

Elaborado	Comprobado	Fecha:	Nombre:	Firma:	
Escrito:	Titulo			EM 500 DIG PLUS MODULO AMPLIFICADOR	
			Sustituye a:		
			Sustituido por:		

600W FM Amplifier Module		
DESCRIPTION	REFERENCE	QUANTITY
SMD 0805 ±10% 50V 1nF Capacitor	C1, C21, C28, C36	4
SMD 0805 ±10% 50V 100nF Capacitor	C2, C23, C29, C34, C37	5
SMD 1206 ±10% 50V 1uF Capacitor	C3, C22, C35	3
SMD 1210 ±10% 200V 22pF Capacitor	C4, C19	2
SMD 1210 ±10% 500V 150pF Capacitor	C6, C7, C17, C18	4
SMD 1210 ±10% 200V 470pF Capacitor	C8, C10, C13, C16	4
SMD 0805 ±5% 50V 47pF Capacitor	C9	1
SMD 0805 ±5% 50V 6.8pF Capacitor	C12	1
SMD 1210 ±10% 500V 15pF Capacitor	C14	1
SMD ≥50V D8mm 100uF electrolytic Capacitor	C24, C33	2
SMD 1206 ±10% 100V 1nF Capacitor	C25, C27, C30, C32	4
SMD 1206 ±10% 100V 10nF Capacitor	C26, C31	2
SMD SOT23 5.1V BZX84C5V1 Zener Diode	D2	1
Binocular Ferrite FT8	FIL1	1
Inductor Dext 8mm 7vuelt Dcable 0.8-1mm enamel wire	L1	1
25Ω Coaxial line	L2, L6	2
50Ω Coaxial line	L3	1
NPN SMD SOT23 PMBT2222A Transistor	Q2	1
SMD 2512 2W 10 Resistance	R1, R4	2
SMD 2512 (270R 2W=2x560R 1W) Resistance	R2	2
SMD 2512 2W 56R Resistance	R3	1
SMD 0805 0.125W ±5% 22 Resistance	R5, R6	2
SMD 0805 0.125W ±5% 2K2 Resistance	R8	1
SMD 0805 0.125W ±5% 12K Resistance	R9	1
Single turn 1K 3/8" 1kΩ Potentiometer	R10	1
SMD 0805 0.125W ±5% 5K1 Resistance	R11	1
SMD 0805 0.125W ±5% 3K9 Resistance	R12	1
SMD 0805 0.125W ±5% 270 Resistance	R13	1
SMD 0805 0.125W ±5% 1K1 Resistance	R14	1
SMD 0805 0.125W ±5% 390 Resistance	R15	1
SMD 0805 0.125W ±5% 4K7 Resistance	R16	1
SMD 0805 0.125W ±5% 910 Resistance	R17	1
Input transformer	TR1	1

600W FM Amplifier Module		
DESCRIPTION	REFERENCE	QUANTITY
Ferrite for input transformer	TR1'	2
Transformer primary copper wire 7xD0.2mm Teflon 1 turn	TR1''	1
Transformer secondary silvered copper wire D1.5mm	TR1'''	1
Hex. Separ. H-H 10mm Brass-Nickel	H1, H2	2

3.1.3 800W Filter

The low pass filter attenuates the harmonics outside band II, at -70dbc levels, being placed in the drainage circuit of the output transistors.

A directional coupler is also included in this section. It provides forward and reflected proportional Vdc voltages depending forward and reflected power. It takes a RF sample not demodulated (MONITOR RF) too, in order to be externally used to make measures with a modulation monitor or frequency-meter. This signal is present at the BNC female connector located in the back panel.

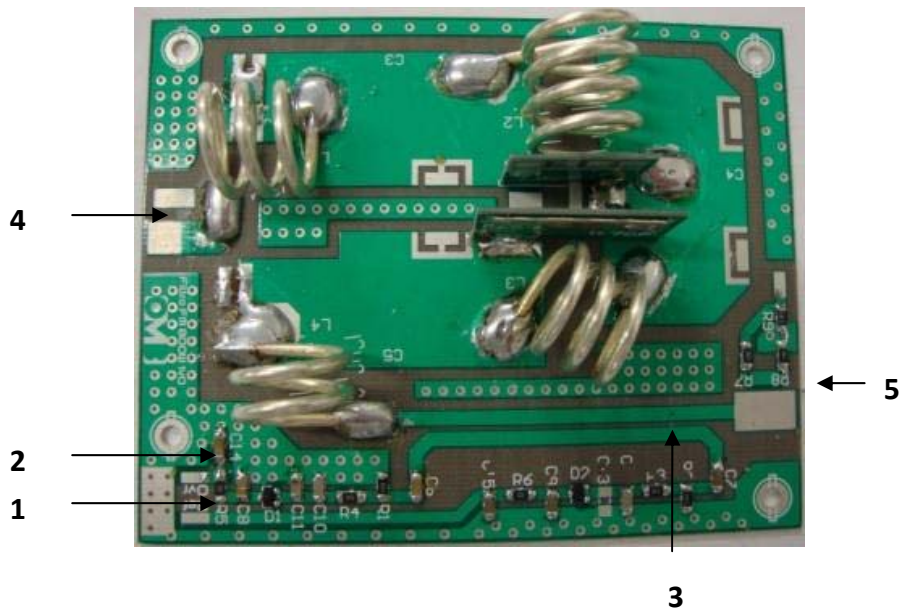
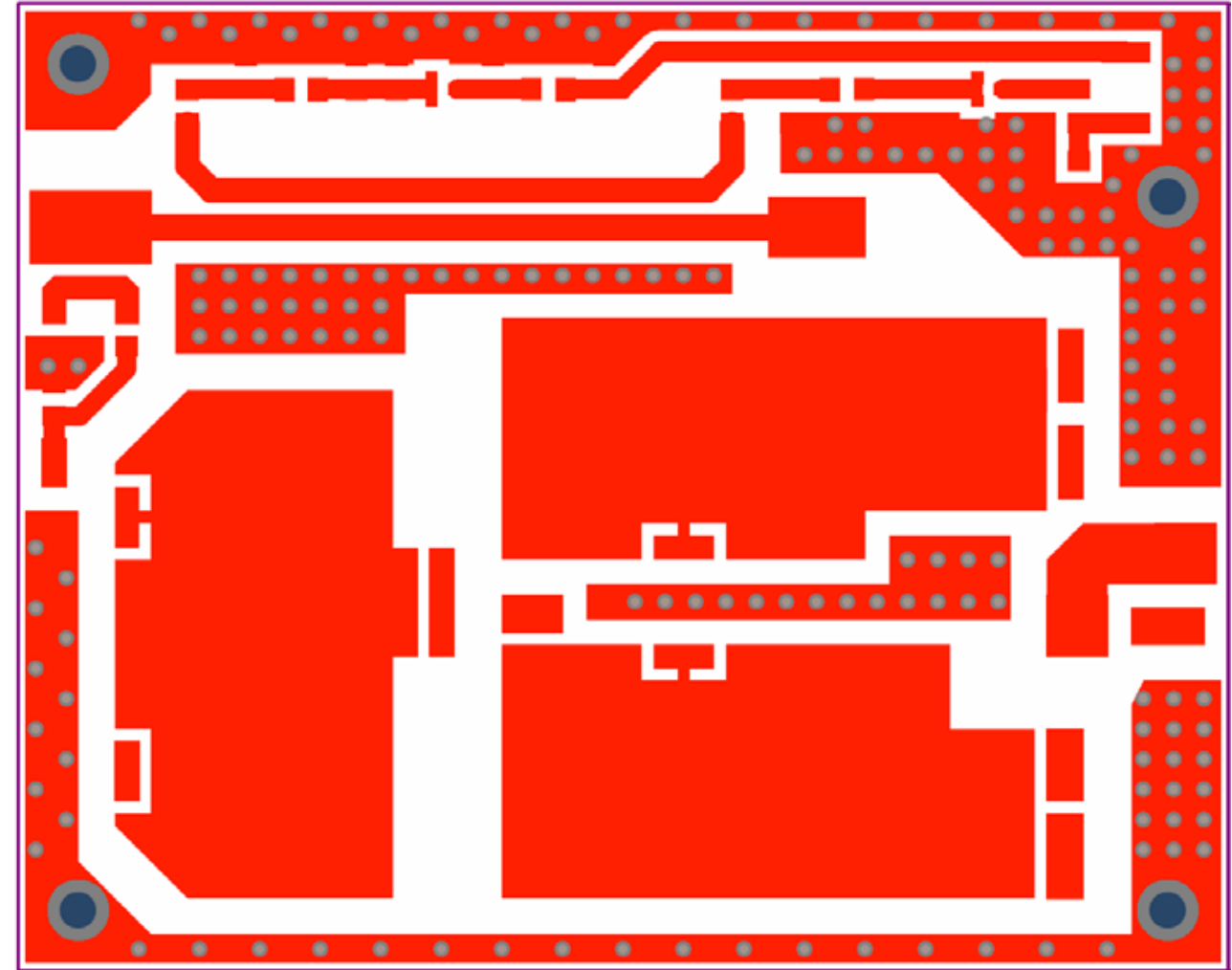
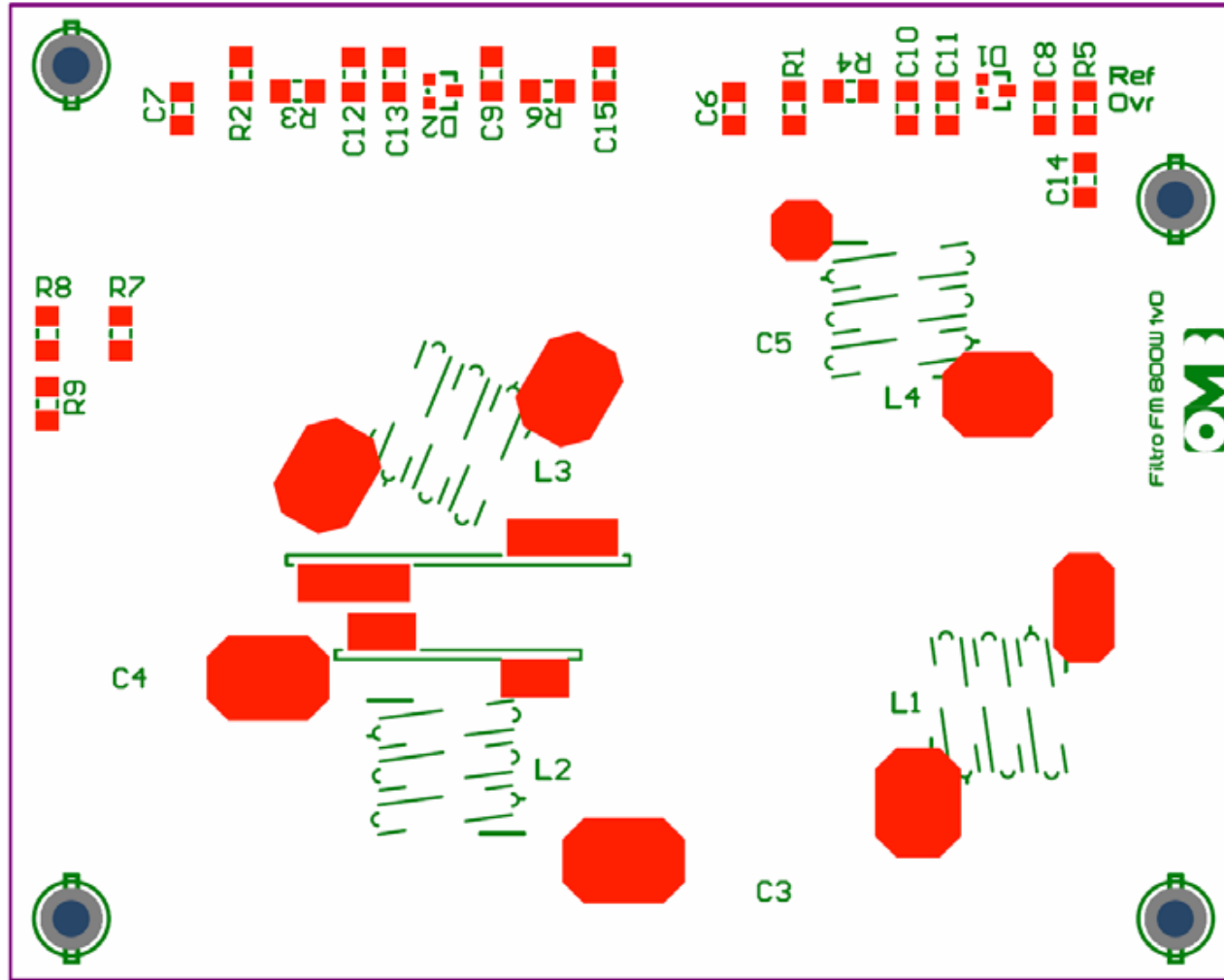



Figure 3-3 800W Filter

These are the numbered elements of the filter in the previous image:

- 1 – Reflected Power Detector.
- 2 – Direct Power Detector.
- 3 – Directional Coupler.
- 4 – RF Input.
- 5 – RF Output.



	Date	Name	Signature:	
Drawn				
Checked				
Scale:	Title		FILTRO 800 W	Drawing nr:
				Replace:
				Replaced with:

800W Filter		
DESCRIPTION	REFERENCE	QUANTITY
PCB filter 800W 1v0	PCB	1
PCB 7.5pF	PCB C1	1
PCB 11.7pF	PCB C2	1
SMD Capacitor 1206 1nF	C6, C7, C8, C9, C14,C15	6
SMD Capacitor 1206 10pF	C10, C12	2
SMD Diode SOT-23 HSMS2800	D1, D2	2
Coil	L1, L2, L3, L4	4
SMD Resistor 1206 100R	R1, R2, R3, R4	4
SMD Resistor 1206 51R	R7, R8, R9	3
SMD Resistor 1206 1k	R5, R6	2

3.1.4 Auxiliary Power Supply

The FMA 500 HE uses an AC/DC power supply, to provide auxiliary voltage to the different parts that make up the device.



Figure 3-4. RD 3513 Power Supply

TECHNICAL SPECIFICATIONS		
Input		
Voltage	88 - 264VAC	125-373VDC
Frecuency	47-63Hz	
Efficiency	80% (typical)	
AC Consumption	0.8A/115VAC 0.55A/230VAC (typical)	
Output		
DC Voltage	13.5V	
Nominal Current	1.3A	
Current Range	0.3 – 2 ^a	
Nominal Power	35.1W	
Adjustable Voltage Range	120mVp-p	
Voltage Tolerance	11.5 – 15.5V	
Line regulation	±0.5%	
Load Regulation	±3.0%	
Alarms		
Overload	110 – 150% potencia de salida nominal	
Overvoltage	56.6 - 66.2V	
General		
Working Temperature	-25 a +70°C	
Storage Temperature	-40 a +85°C	
Working Humidity	20-90%HR without condensation	
Humidity dampness	10-95%HR without condensation	
Dimmensions	98x82x36mm	
Weight	0.3kg	

3.1.5 Compada Board.

This card has the following functions:

- Connects the +/-12V power supply to modulator.
- Controls power supply level voltage of the RF power stage.
- It helps to improve the device's efficiency in the whole working power range, reducing the supply voltage at the same time the output power reduces.
- This function can be set according to the type of power supply in use, according to the transmitter.
- Controls the speed fans in FM amplifiers in relation to their own temperature. By this, the device consumes less in airing and the acoustic noise decreases, improving the efficiency.

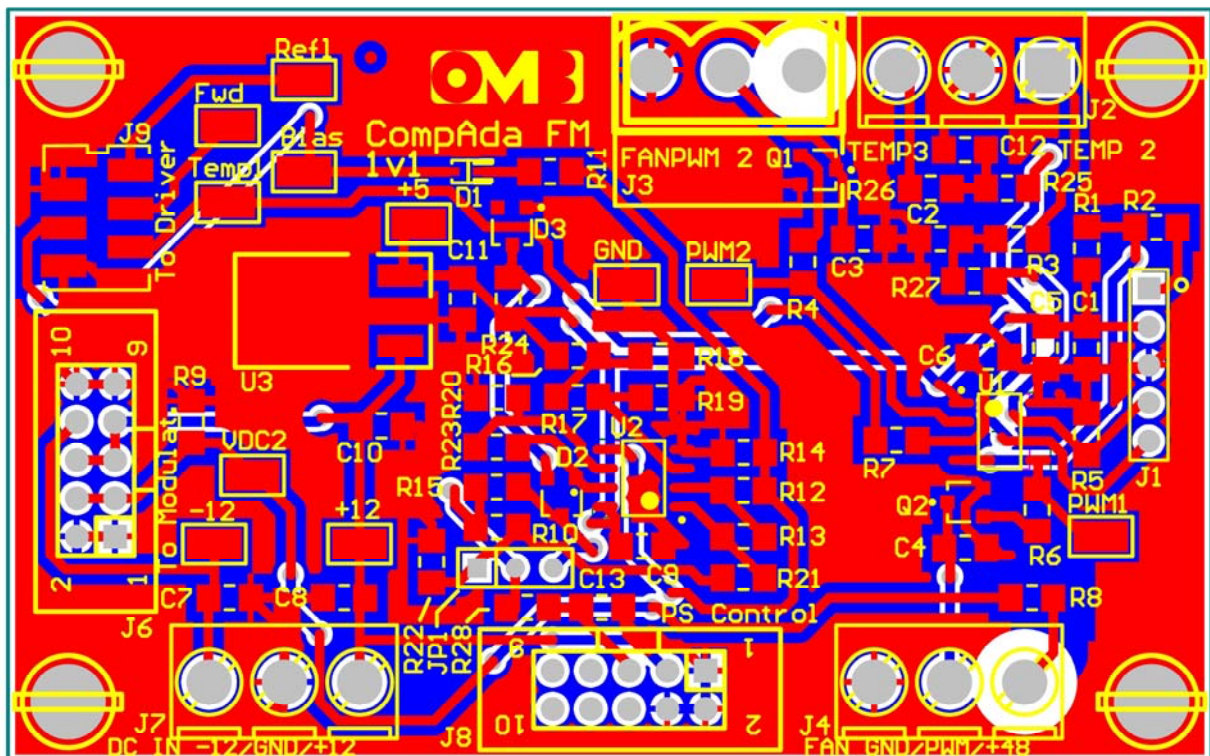

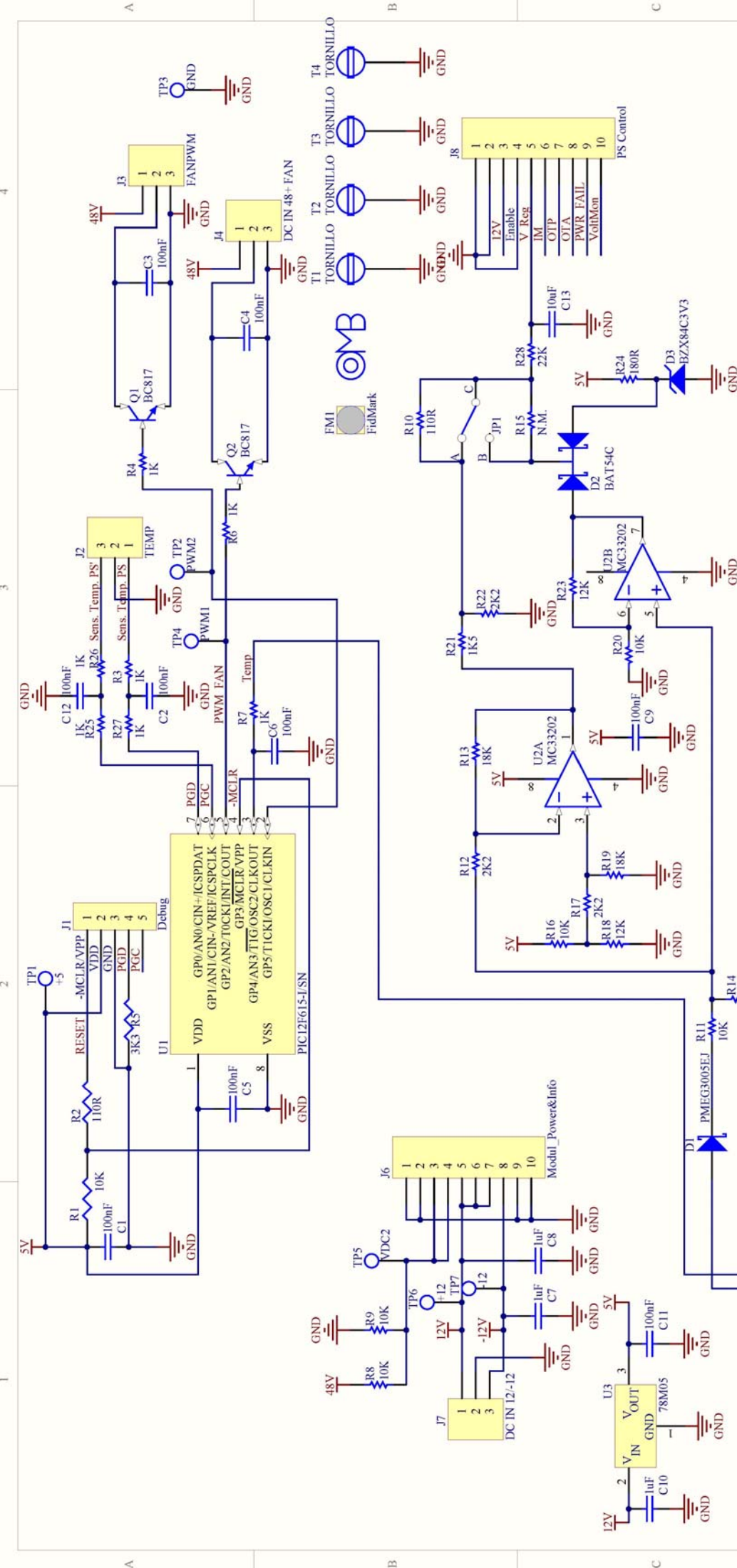

		Firma:	
		Fecha	Nombre
Dibujado	01/02/11	JL Rueda	
Comprobado	01/02/11	JL Rueda	
Escala:	Título		
	EM 500 DIG PLUS		
	Adapt. Amplif. Compactos		
Nº plano:		42.04.02.001	
Susitituye a:		42.04.02.000	

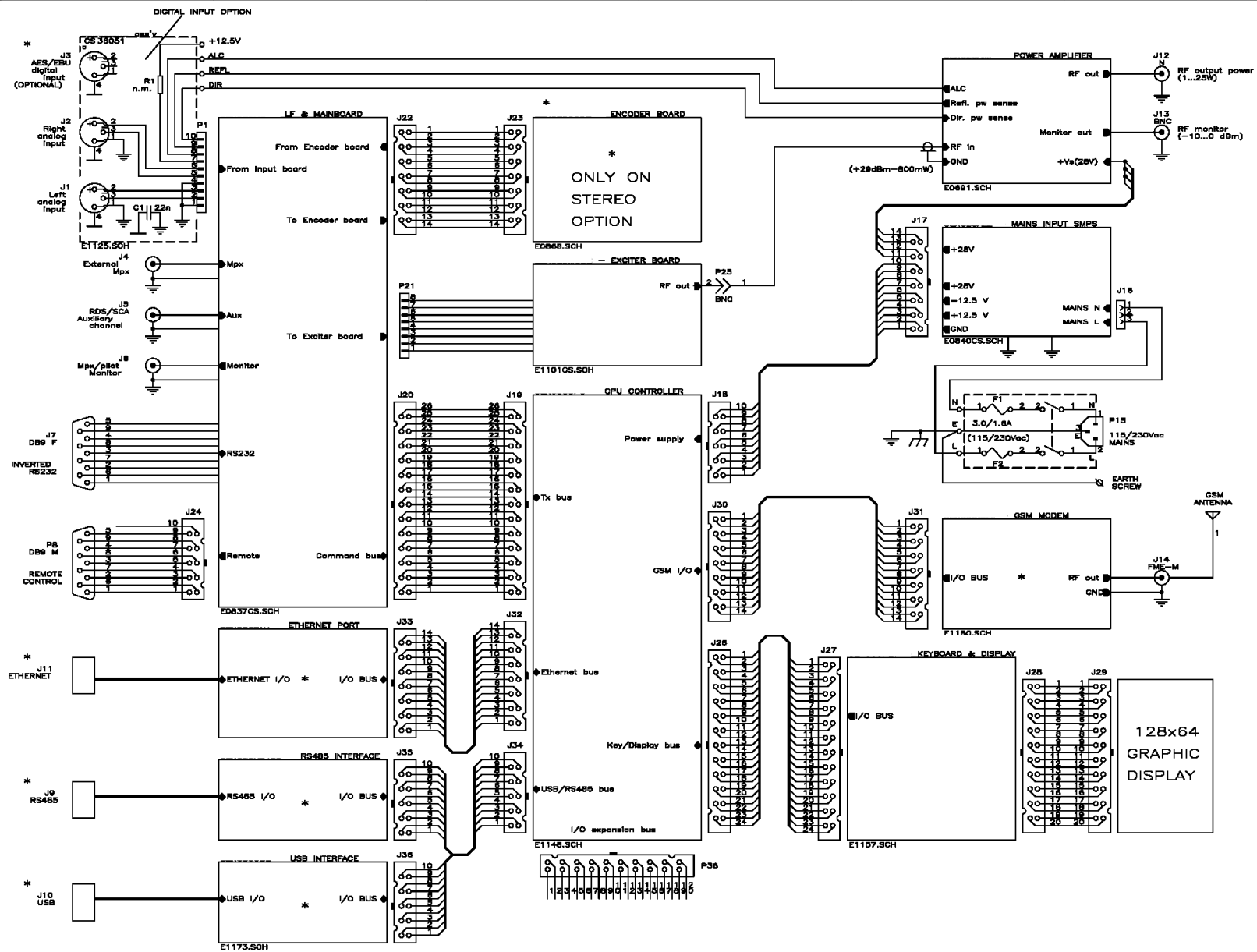

	Fecha	Nombre	Firma:
Dibujado			
Comprobado			
Escala:	Titulo		Nº plano:
	EM 500 DIG PLUS General Wiring Diagram		
			Sustituye a:
			Sustituido por:



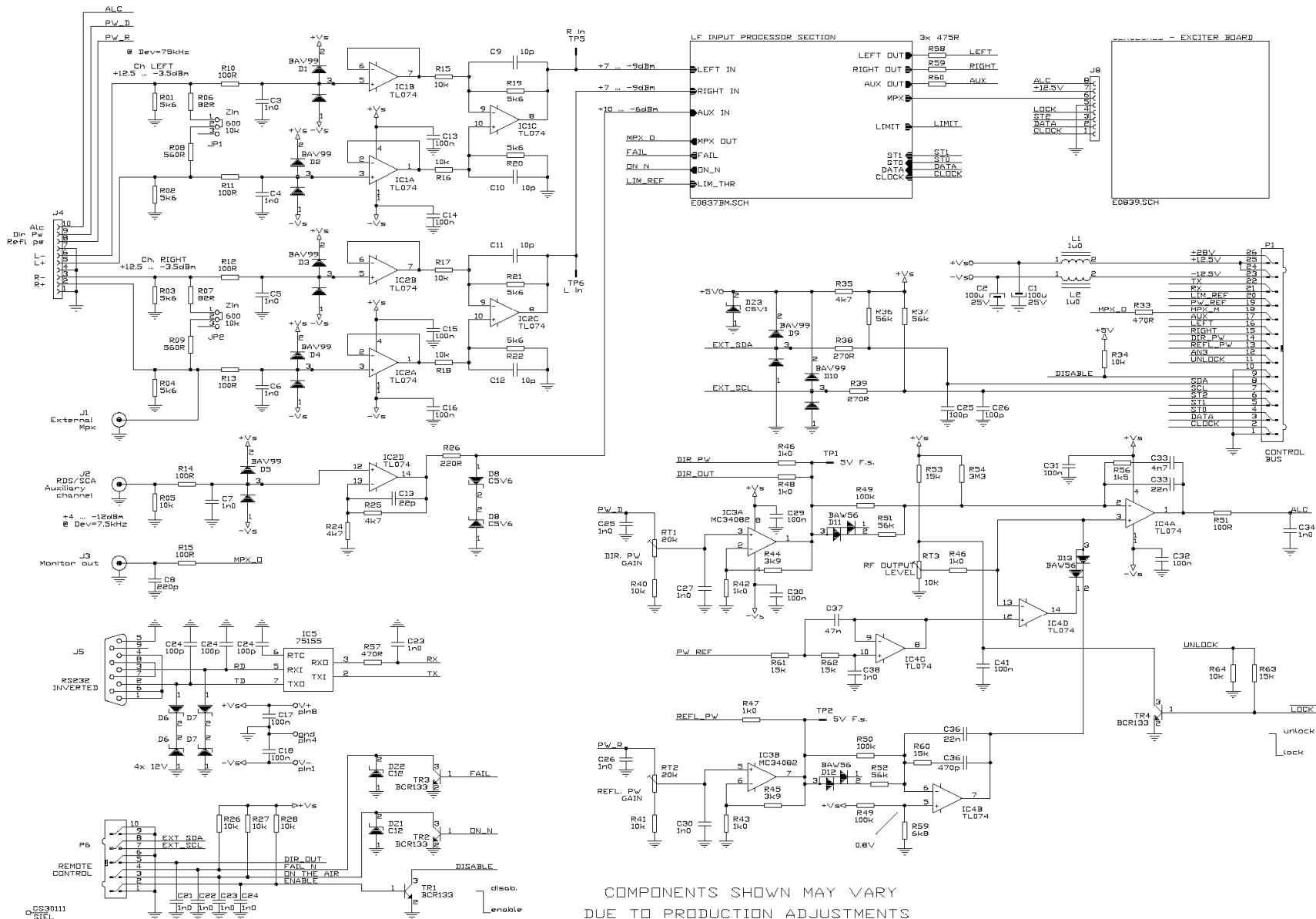



COMPONENTS SHOWN MAY VARY
DUE TO PRODUCTION ADJUSTMENTS

		Fecha	Nombre	Firma:
Dibujado				
Comprobado				
Escala:	Titulo			
	EM 500 DIG PLUS Main Board 1/2			
				Nº plano:
				Sustituye a:
				Sustituido por:

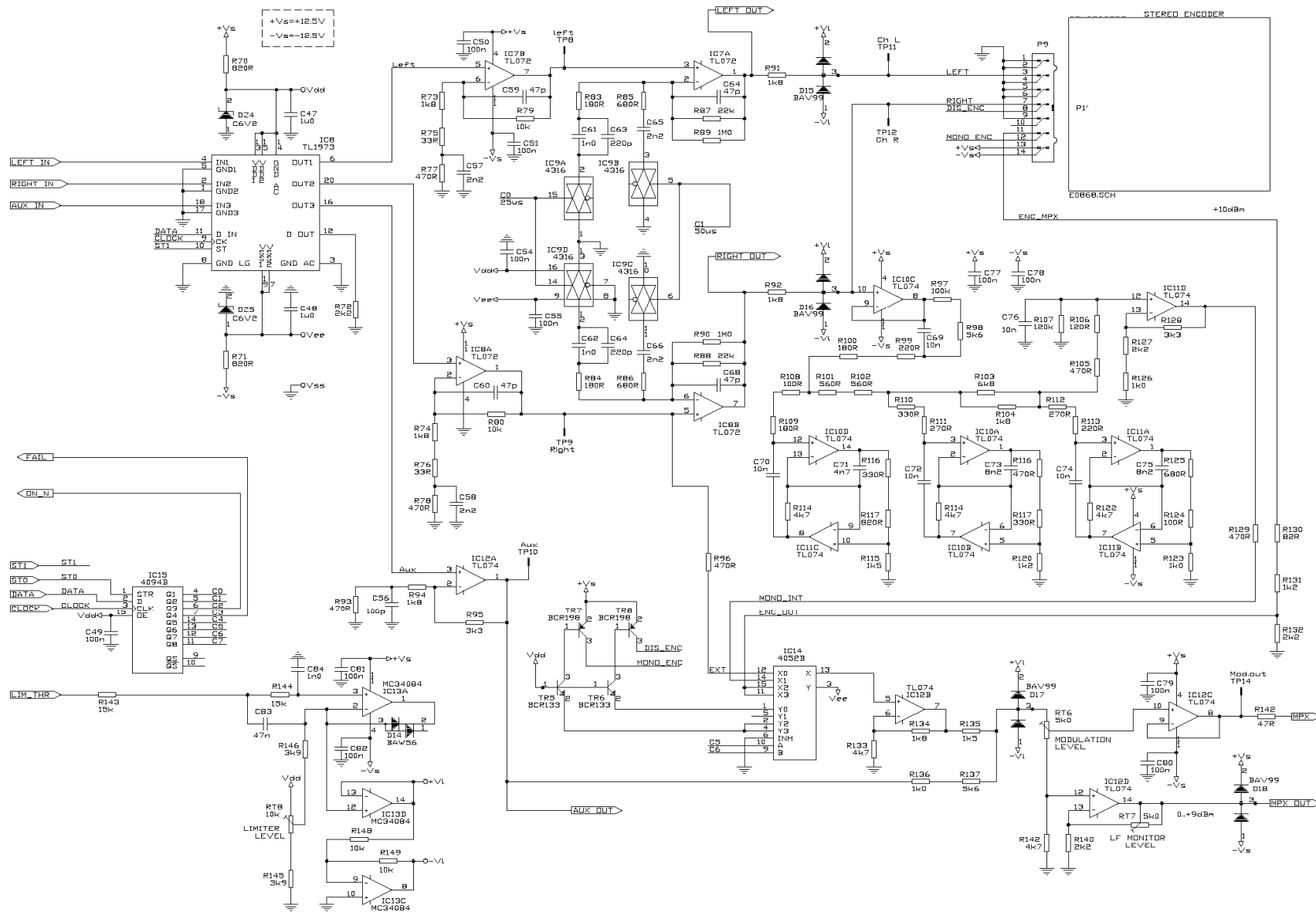



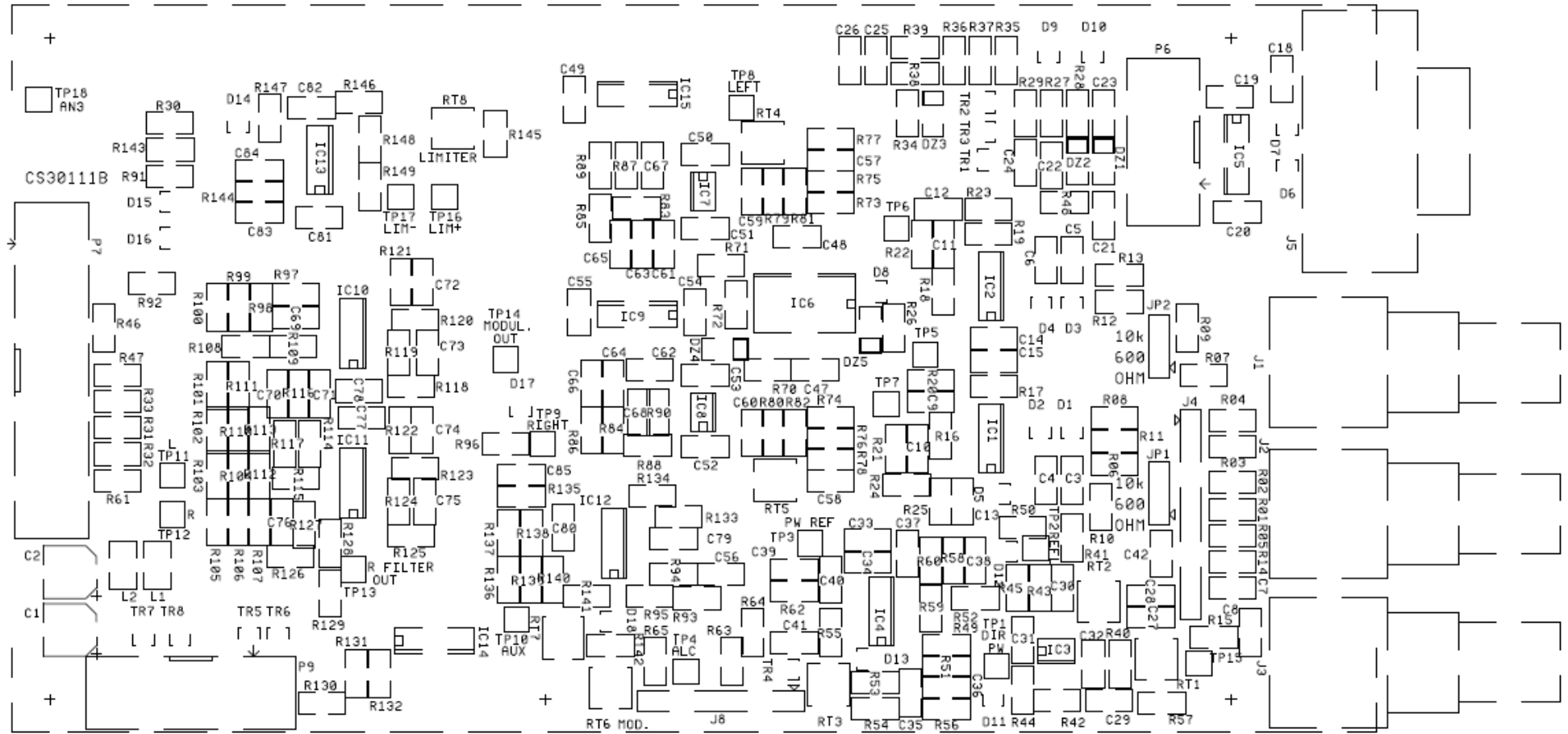

	Fecha	Nombre	Firma:	
Dibujado Comprobado				
Escala:	Titulo		Nº plano:	
	EM 500 DIG PLUS Main Board 2/2		Sustituye a: Sustituido por:	

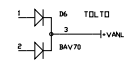
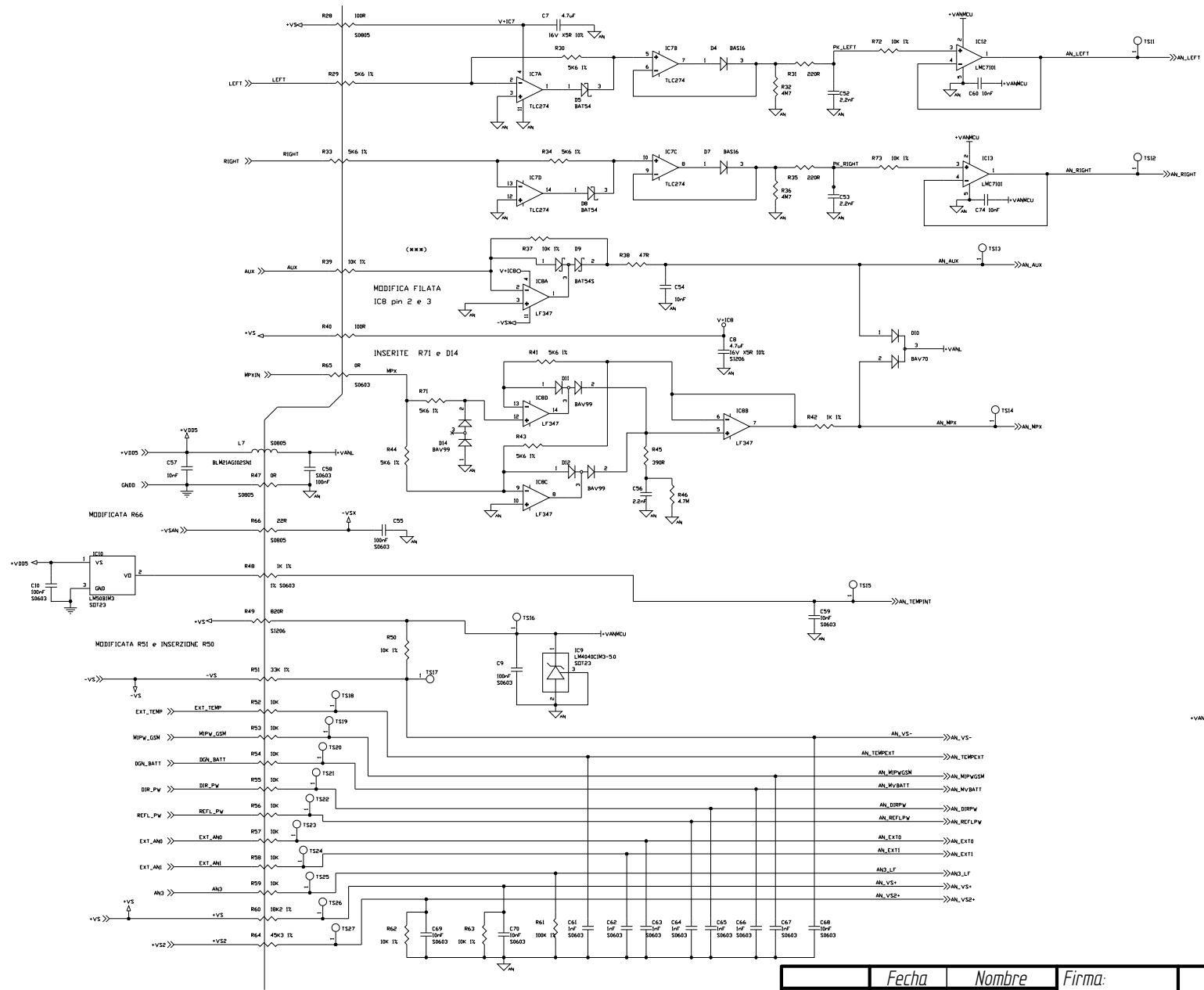

	Fecha	Nombre	Firma:	
Dibujado				
Comprobado				
Escala:	Titulo		Nº plano:	
	EM 500 DIG PLUS Main Board Layout			
			Sustituye a:	
			Sustituido por:	



	Fecha	Nombre	Firma:	
Dibujado				
Comprobado				
Escala:	Titulo		Nº plano:	
	EM 500 DIG PLUS Controller Board 2/3		Sustituye a: Sustituido por:	

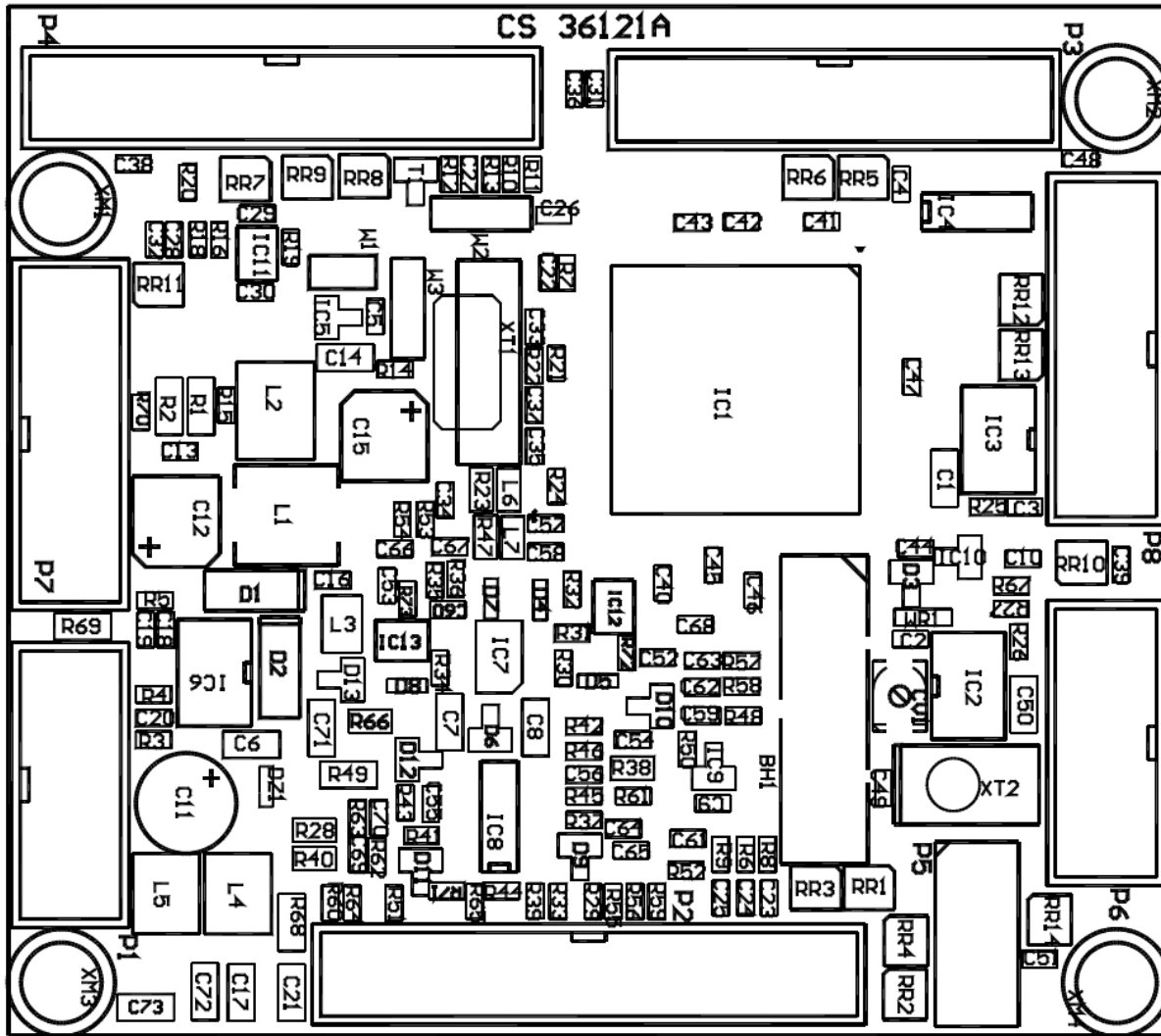

	Fecha	Nombre	Firma:	
Dibujado				
Comprobado				
Escala:	Titulo		Nº plano:	
	EM 500 DIG PLUS Controller Board Layout		Sustituye a:	
			Sustituido por:	

S = +4dBm

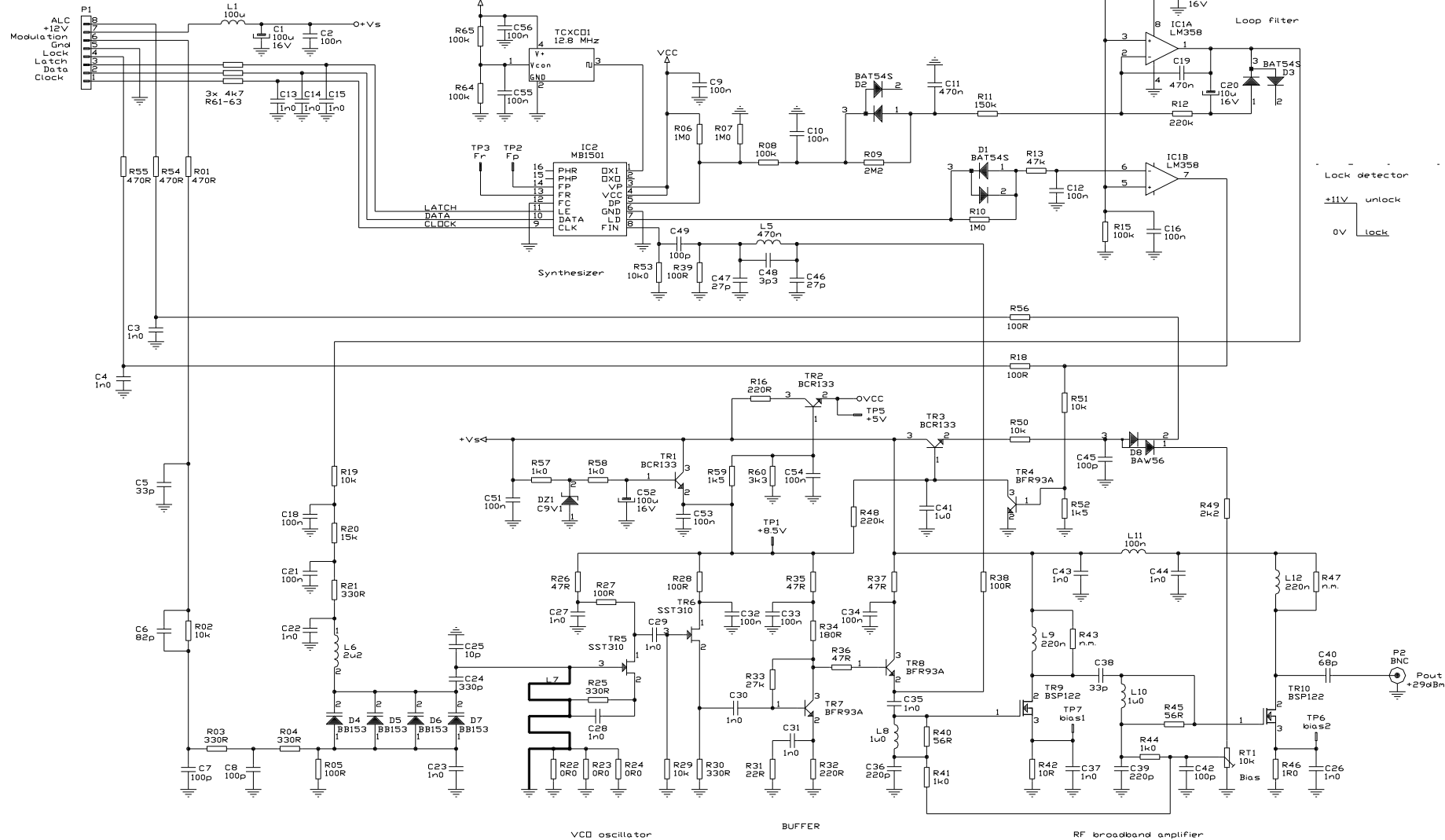

COMPONENTS MAY VARY DUE TO PRODUCTION ADJUSTMENTS

CS29041A

	Fecha	Nombre	Firma:	
Dibujado				
Comprobado				
Escala:	Titulo		Nº plano:	
	EM 500 DIG PLUS FM Exciter			
			Sustituye a:	
			Sustituido por:	

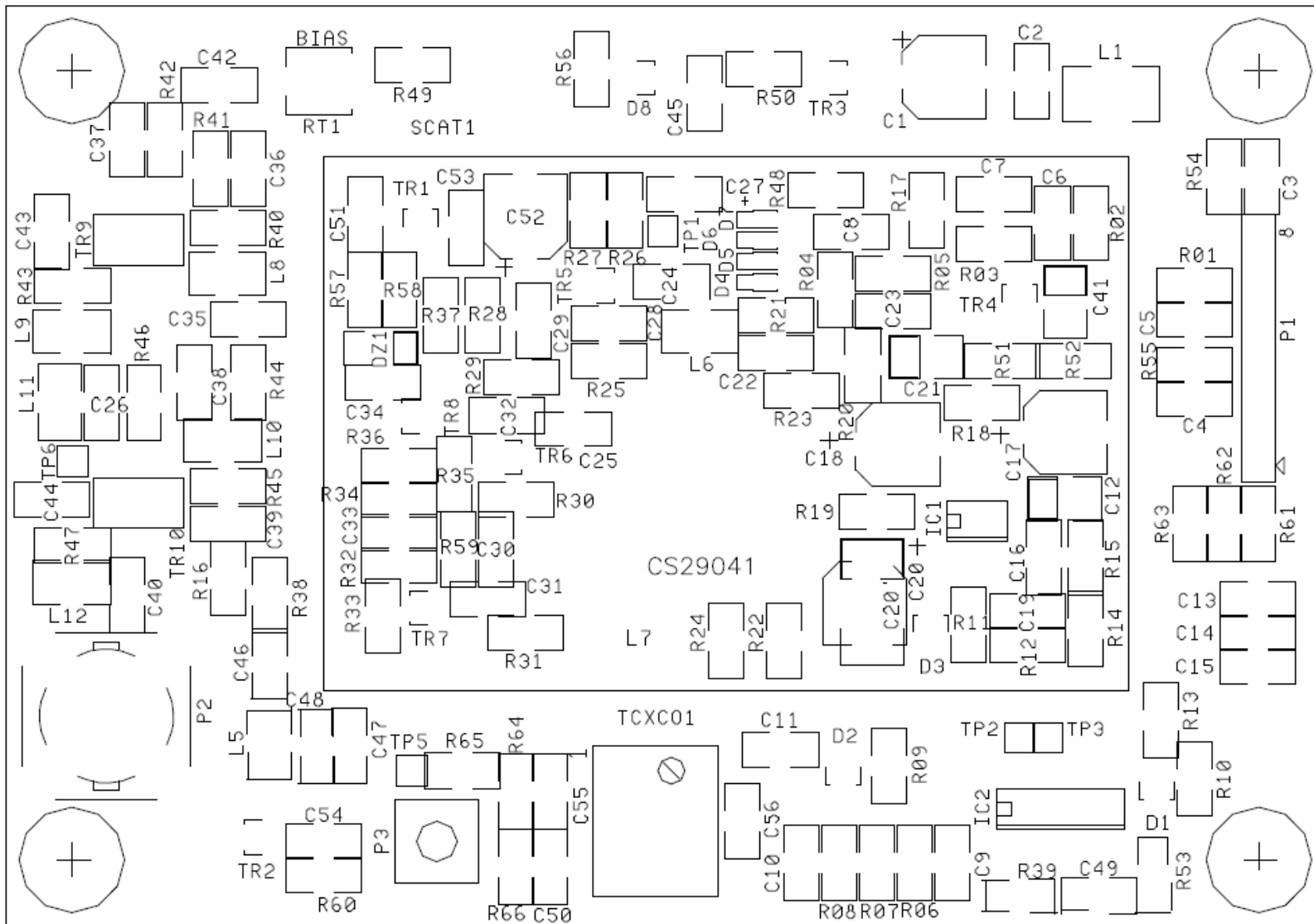

	Fecha	Nombre	Firma:
Dibujado			
Comprobado			
Escala:	Titulo		Nº plano:
	EM 500 DIG PLUS FM Exciter Layout		
			Sustituye a:
			Sustituido por:



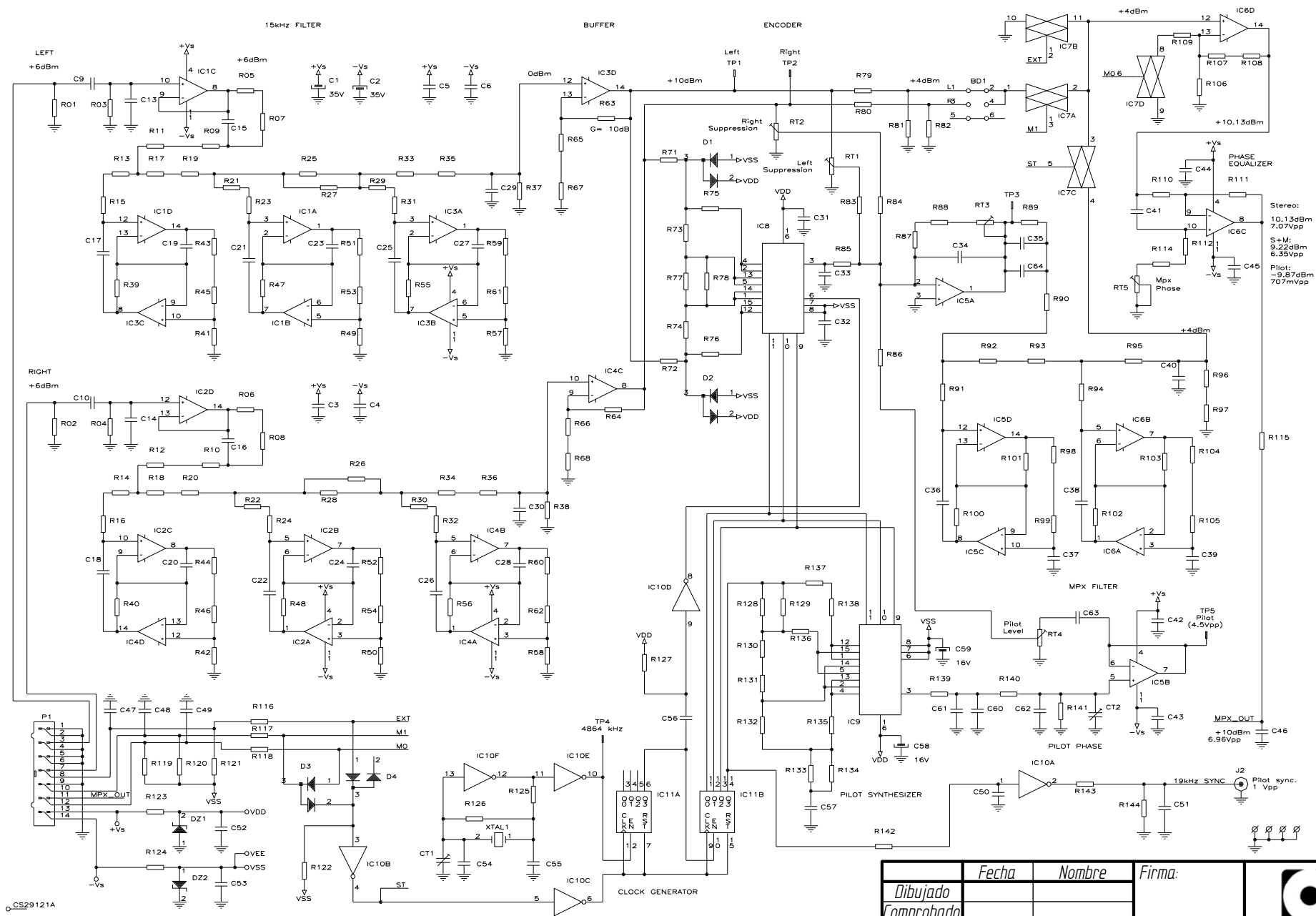

Stereo:
10.13dBm
7.07Vpp
S+M:
9.22dBm
6.35Vpp
Pilot:
-9.97dBm
707mVpp

TP5 Pilot
(4.5Vpp)

J2 Pilot sync.
1 Vpp

CS29121A

	Fecha	Nombre	Firma:
Dibujado			
Comprobado			
Escala:	Titulo		Nº plano:
	EM 500 DIG PLUS Stereo Encoder (OPTIONAL)		Sustituye a: Sustituido por:



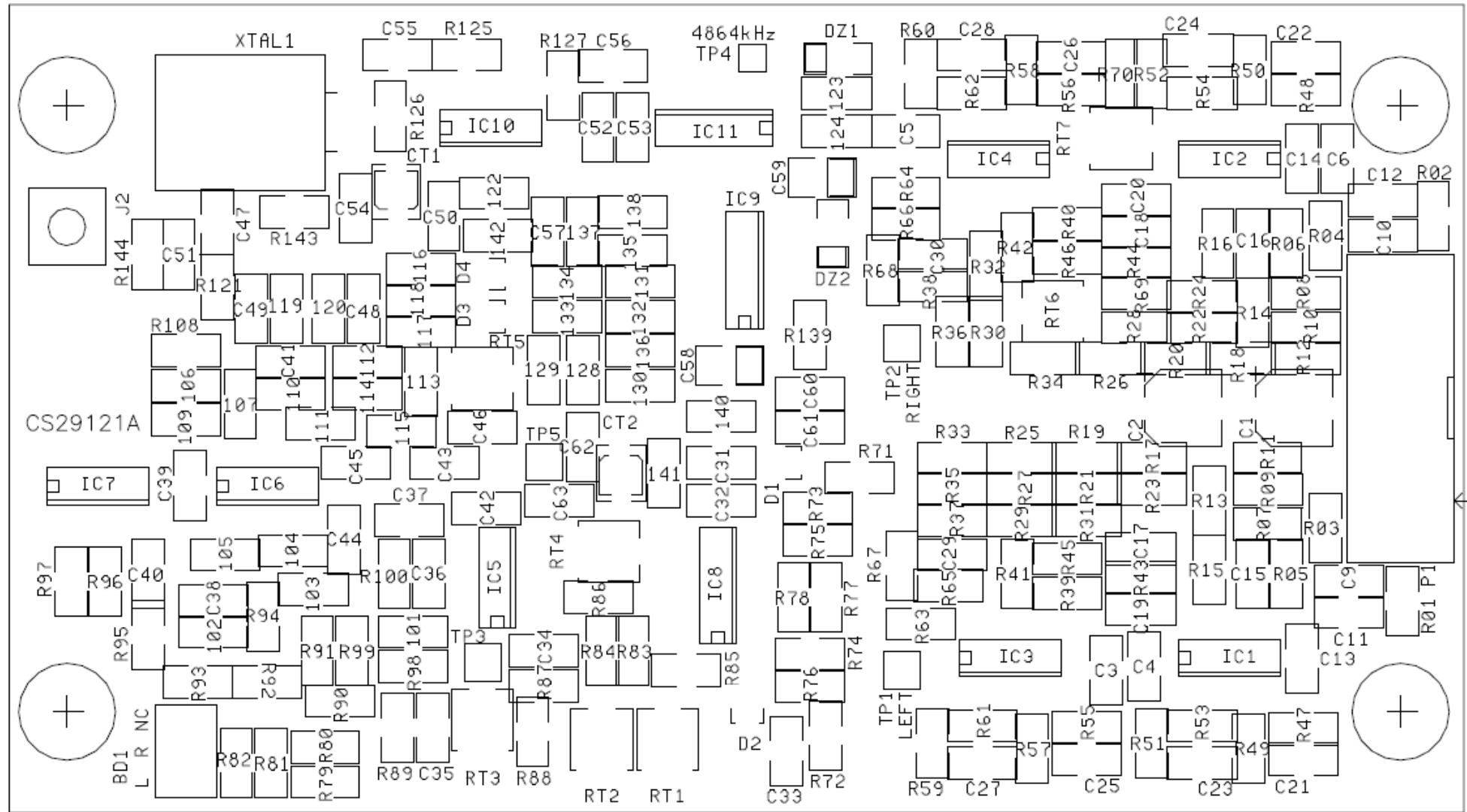

	Fecha	Nombre	Firma:	OMB BROADCAST
Dibujado				
Comprobado				
Escala:	Titulo		Nº plano:	
	EM 500 DIG PLUS Stereo Encoder Layout (OPTIONAL)			
			Sustituye a:	
			Sustituido por:	

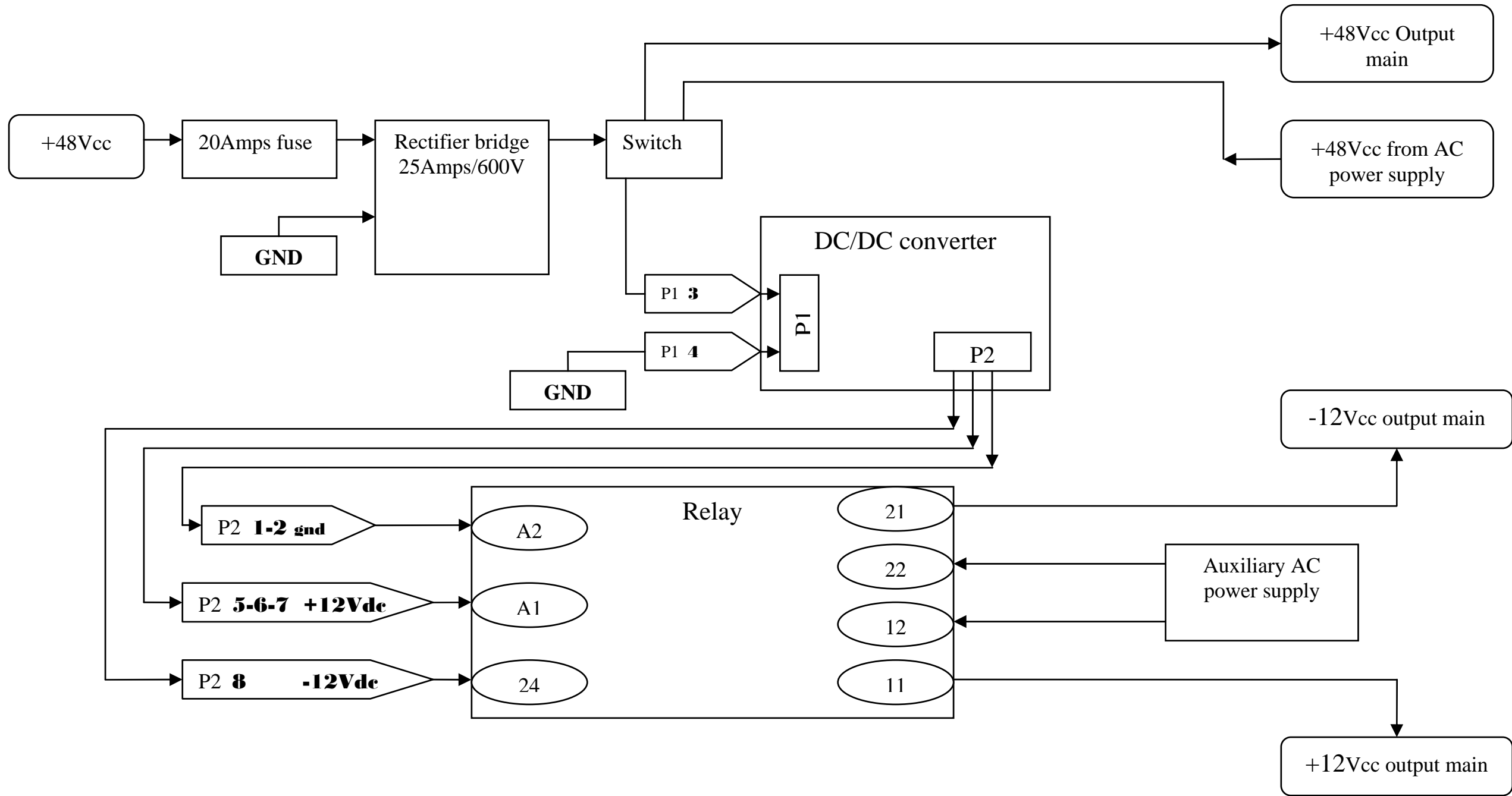

	Date	Name	Signature:	
Drawn				
Checked				
Scale:	Title		Drawing nr:	
	EM 500 HE DIG PLUS COMPACT 48Vcc (OPTIONAL)		Replace:	
			Replaced with:	

R&TTE DIRECTIVE 1999/5/CE

Declaration of Conformity

English:	This equipment is in compliance with the essential requirements and other relevant provisions of Directive 1999/5/EC
Deutsch:	Dieses Gerät entspricht den grundlegenden Anforderungen und den weiteren entsprechenden Vorgaben der Richtlinie 1999/5/EU.
Dansk:	Dette udstyr er i overensstemmelse med de væsentlige krav og andre relevante bestemmelser i Direktiv 1999/5/EF.
Español:	Este equipo cumple con los requisitos esenciales así como con otras disposiciones de la Directiva 1999/5/EC.
Ελληνικά:	Αυτός ο εξοπλισμός συμμορφώνεται με τις ουσιαστικές απαιτήσεις και τις λοιπές διατάξεις της Οδηγίας 1999/5/EK
Français:	Cet appareil est conforme aux exigences essentielles et aux autres dispositions pertinentes de la Directive 1999/5/EC.
Íslenska:	Þessi búnaður samrýmist lögboðnum kröfum og öðrum ákvæðum tilskipunar 1999/5/ESB.
Italiano:	Questo apparato é conforme ai requisiti essenziali ed agli altri principi sanciti dalla Direttiva 1999/5/EC.
Nederlands:	Deze apparatuur voldoet aan de belangrijkste eisen en andere voorzieningen van richtlijn 1999/5/EC.
Norsk:	Dette utstyret er i samsvar med de grunnleggende krav og andre relevante bestemmelser i EU-direktiv 1999/5/EC.
Português:	Este equipamento satisfaz os requisitos essenciais e outras provisões da Directiva 1999/5/EC.
Suomalainen:	Tämä laite täyttää direktiivin 1999/5/EY oleelliset vaatimukset ja on siinä asetettujen muidenkin ehtojen mukainen.
Svenska:	Denna utrustning är i överensstämmelse med de väsentliga kraven och andra relevanta bestämmelser i Direktiv 1999/5/EC.

The following CE mark is affixed to the equipment:

CE 0341 

The identification number of the Notified Body who certified the product might change.

The use of this equipment may be restricted to certain frequencies and may require a license for operation. For more details, contact with your nearest local administration.

Legal Notice:

According to the European directives, 2002/96/CE and 2003/108/CE, it is forbidden to trash **Waste Electrical and Electronic Equipment (WEEE)** products along with normal wastes. The equipment classified cannot be disposed as urban waste but it must be sent to the specific collecting centres prepared by the municipal government and they will arrange the separate collection of WEEE.

The under-reproduced symbol indicates that the unit at the end of its life has to be considered WEEE (Waste of Electrical and Electronic Equipment).



Toxic materials – Product and environmental safety

Some components used in the construction of this equipment contain **Beryllium Oxide (BeO)**. The product is entirely safe provided that the BeO discs are not damaged. Do not disassemble, crush or dispose of this product with normal waste. All persons who handle, use or dispose of this product should be aware of its nature and of the necessary safety precautions. After use, dispose of as chemical or special waste according to the regulations applying at the location of the user. It must never be thrown out with the general or domestic waste.



INTENTIONALLY BLANK