

TS-RDP6

USB2.0 Compact Card Reader

Description

TS-RDP6 is a USB2.0 Compact Card Reader. It is designed for fast, easy data transfer and exchange using multiple types of Memory Cards.

Features

- Color: Black(Cap & Case)/Red(Frame)
- Fully Compliant with the Hi-Speed USB 2.0 specification
- Hi-Speed Data transfer rates of up to 480Mb/s
- USB powered (no external power or battery needed)
- LED indicates card insertion and data traffic
- Compatible Cards :

Directly:

- Memory Stick
- Memory Stick PRO
- Memory Stick Duo
- Memory Stick PRO Duo
- Memory Stick PRO-HG Duo
- Memory Stick Micro (M2)
- microSDHC
- microSD / TransFlash

Placement

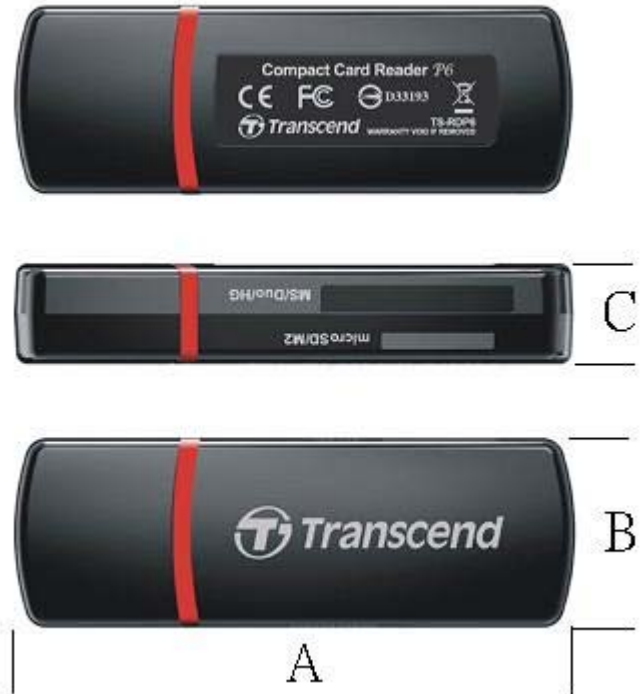

Dimensions

Side	Millimeters	Inches
A	66.90 ± 1.0	2.63 ± 0.04
B	22.60 ± 1.0	0.89 ± 0.04
C	12.00 ± 1.0	0.47 ± 0.04

System Requirements

- Desktop or notebook computer with a working USB port
- One of the following Operating Systems:
 - Windows® Me
 - Windows® 2000
 - Windows® XP
 - Windows Vista™
 - Mac™ OS 9.0, or later
 - Linux™ Kernel 2.4.2, or later

TS-RDP6

USB2.0 Compact Card Reader

Pinouts

Pin No.	Pin Name
01	V _{USB}
02	USB-
03	USB+
04	VSS

Pin Identification

Symbol	Function
USB-	USB differential signal: The pairs are used to transmit Data/Address/Command
USB+	
VSS	Ground
V _{USB}	USB Power Input

Block Diagram

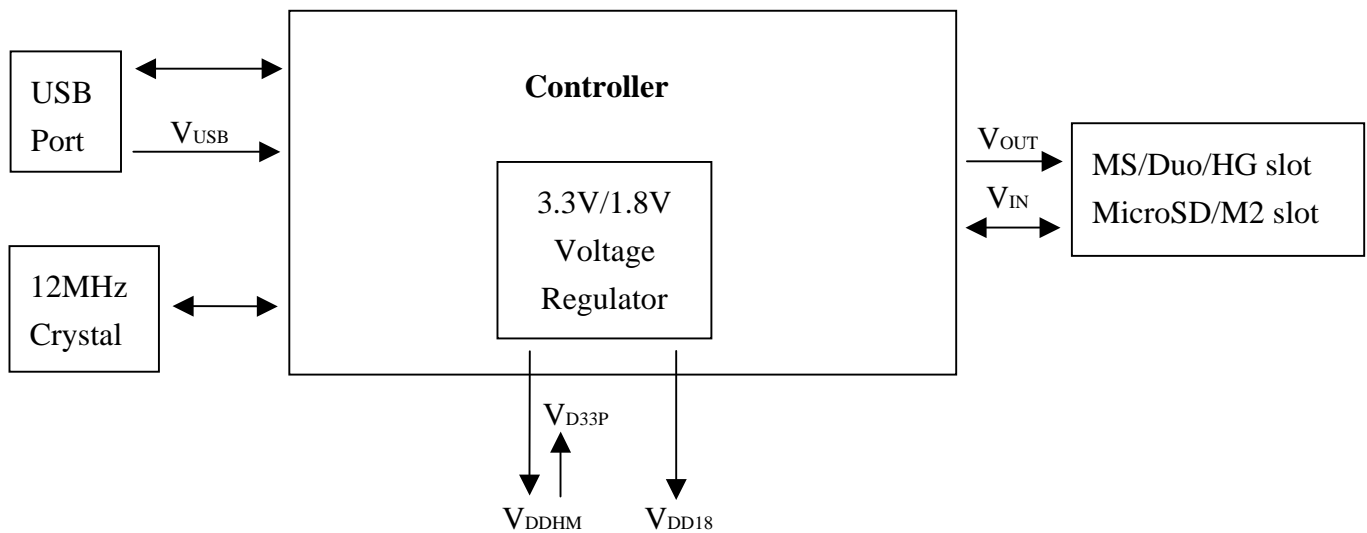

Recommended Operating Conditions:

SYMBOL	PARAMETER	MIN.	TYP.	MAX.	UNITS
V _{USB}	Power Supply	4.5	5.0	5.5	V
T _{OPR}	Operating Temperature	0		70	°C

DC Characteristics:

SYMBOL	PARAMETER	MIN.	TYP.	MAX.	UNITS
V _{DDHM}	Input Voltage	3.0	3.3	3.6	V
V _{IN}	Input Signal Voltage	-0.3		V _{DDHM} +0.3	V
V _{OUT}	Output Voltage	3.0	3.3	3.6	V
V _{DD18}	Supply Voltage	1.62	1.8	1.98	V

DC Electrical Characteristics of 3.3V I/O:

SYMBOL	PARAMETER	MIN.	TYP.	MAX.	UNITS
V _{D33P}	Supply Voltage	3.15	3.3	3.6	V
V _{IL}	Input Low Voltage			0.8	V
V _{IH}	Input High Voltage	2.0			V
V _{OL}	Output Low Voltage			0.4	V
V _{OH}	Output High Voltage	2.4			V

Above technical information is based on industry standard data and tested to be reliable. However, Transcend makes no warranty, either expressed or implied, as to its accuracy and assumes no liability in connection with the use of this product. Transcend reserves the right to make changes in specifications at any time without prior notice.