

User Manual

Body Fat Analyzer BF-1256-B1

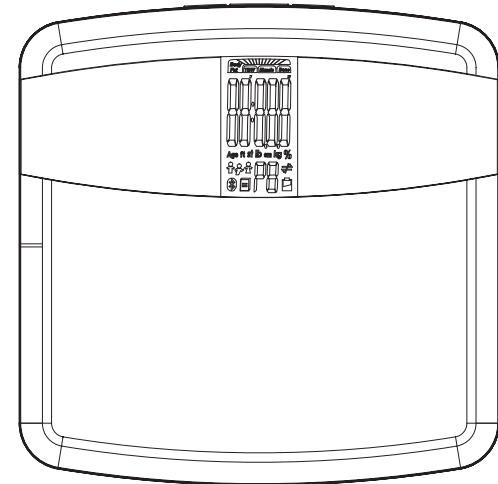

- Thank you very much for selecting the Transtek Body Fat Analyzer BF-1256-B1.
- Please do read the user manual carefully and thoroughly so as to ensure the safe usage of this product, and keep the manual well for further reference in case you have problems.



Contains FCC ID: OU9AW8001-LS









GUANGDONG TRANSTEK MEDICAL ELECTRONICS CO., LTD
Zone A, 5/F., Investment Building, No. 12, Huizhan East Rd., Torch Development
District, Zhongshan, Guangdong, 528437, China
TEL:86-760-88282982 www.transtek.cn

Table of Contents

- Safety Information**
- Safety and Usage Information 2
- Tips 3
- Overview**
- Device Components 4
- List 4
- LCD Display 5
- Initial Start-Up**
- General Instructions 6
- Power Supply 6
- Insert the Batteries 6
- Pair-up 7
- Set Up Your Profile 8-9
- Select Measurement Unit 9
- Initialising Your Scale 10
- Weight Only Operation 10
- Start Measuring**
- First Measurement 11
- Daily Measurement 12
- Manage Your Health**
- Body Fat Indicator 13
- Data Transmission 13
- Troubleshooting**
- Error Prompt 14
- When Measuring 14-15
- When Data Transmitting... 16
- Specifications** 17
- Maintenance** 18
- Warranty** 18
- FCC Regulations** 19
- Appendix**
- Table of Body Fat Level 20
- Table of Body Water Level 20
- Muscle Mass Percentage 20
- Bone Mass Percentage 21
- Health Tips – About Body Fat 21
- EMC Guidance 21-24

♥ Safety and Usage Information

The warning signs and symbols are essential to ensure your correct and safe use of this product and protect you and others from injury. Please kindly find the meanings of the warning signs and symbols, which you may encounter in the label and user manual, as follows:

	Symbol for "THE OPERATION GUIDE MUST BE READ"		Symbol for "MANUFACTURER"
	The Bluetooth Combination Mark		Symbol for "DIRECT CURRENT"
	Symbol for "TYPE BF APPLIED PARTS"		Symbol for "ENVIRONMENT PROTECTION – Waste electrical products should not be disposed of with household waste. Please recycle where facilities exist. Check with your local authority or retailer for recycling advice"
	Symbol for "MANUFACTURE DATE"		
SN	Symbol for "SERIAL NUMBER"		

 CAUTION

Transtek's Body Fat Analyzer BF-1256-B1 offers you a seamless way to manage your health. Please be aware that this device is designed for healthy population over 10 years old self-measuring and self-monitoring body compositions. Any information provided by this device is in no way meant to treat, cure or prevent any disease or illness from happening. If in doubt, contact your physician.

This device is contraindicated for any female subject who may be suspected of, or is pregnant. Otherwise, the effects of this device on the fetus are unknown.

This device is contraindicated for any person who is connected to a wearable or implantable electronic device or instrument such as a pacemaker or defibrillator.

This device should not be used for anyone who is acutely or chronically ill because of suffering from a disease or taking medications that affect your water levels. The accuracy of readings for these patients has not been verified. Specific medical advice should be obtained from a physician.

BF-1256-B1 is equipped with data transmission function. It may emit electromagnetic energy so as to perform its intended function. Nearby portable and mobile RF communications equipment can affect the performance of BF-1256-B1. And the device can interfere vicinity electrical equipment.

Manufacturer will make available on request circuit diagrams, component parts list, etc.

WARNING:No modifications of this equipment is allowed. This may result in increased EMISSIONS or decreased IMMUNITY of BF-1256-B1.

Please use the device according to the user manual. Any misuse can cause electric shock, burns, fire and other unexpected hazards.

Please use and storage the device under the environment which was provided in the user manual.

Don't expose the device to extreme temperatures, direct sunlight, moist or corrosive environment.

Do not step on the scale when your body or feet are wet, especially after bathing or showering to prevent slipping.

INDICATIONS FOR USE

- The Transtek Body Fat Analyzer measures weight and uses bio-electrical impedance analysis (BIA) technology to estimate body fat, total body water percentage, bone mass, and muscle mass in generally healthy children 10-17 years old and healthy adults.
- It is intended for use in the domestic setting only.

♥ Tips

To ensure the accuracy of measurement, please follow below instructions when you start measurement.

- Place the scale on a flat, hard surface. Soft surface such as carpet will affect the performance of the scale.
- Step onto the platform with bare feet. Stand still and keep full contact with the electrodes until the measurement is complete.
- Start measurement at least two hours after Getting up or Dinning.
- Avoid measurement immediately after strenuous exercise, sauna or bath, drinking, and dinning.
- Always start measurement in the same time slot and on the same scale located on the same flat, hard surface.
- For maximum accuracy and repeatability , it is recommended that you should use the device in the same time of the day and on the same location.
- The condition of the skin on the bottom of your feet can affect the reading. The natural effects of aging or activity can make this skin hard. Take the reading with clean, slightly damp feet for best accuracy. If you are having a problem on operating this scale please contact customer service.
- Body fat percentage estimates will vary with the amount of water in the body, and can be affected by dehydration or over-hydration due to such factors as alcohol consumption, menstruation, illness, intense exercise, etc.

To prevent you from injury, please pay attention to the following Notice.

- Small parts being inhaled or swallowed.
- Potential allergic reactions to accessible materials used in the ME EQUIPMENT.
- Contact injuries.
- Use accessories, detachable parts and materials not described in the instructions for use.
- A list of known devices or other sources that can potentially cause interference problems (example 1 Heat from a fireplace or radiant heater. example 2 Moisture from a nebuliser or steam kettle).
- The effects of degraded sensors and electrodes, or loosened electrodes, that can degrade performance or cause other problems.
- The effects caused by pets, pests or children.

♥ Device Components

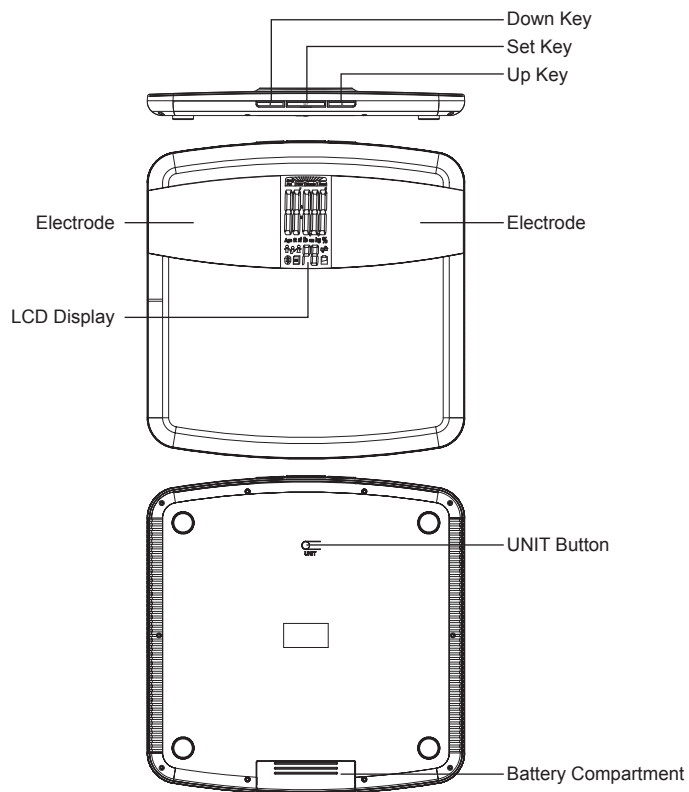

♥ List

1. Body Fat Analyzer BF-1256-B1
2. Four AAA-size Batteries (1.5V each)
3. User Manual

♥ LCD Display

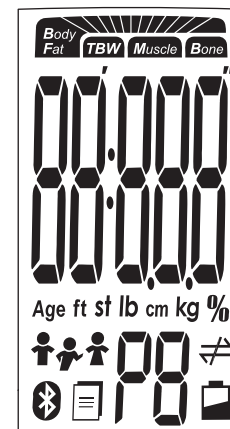

Body Fat	Body Fat Analysis Result	%	Percentage
TBW	Total Body Water Analysis Result	♂	Man
Muscle	Muscle Mass Analysis Result	♂♂	Sportsman
Bone	Bone Mass Analysis Result	♀	Woman
Age	Age	♂♀	Sportswoman
ft	Foot	98	User ID
st lb	Stone	Bluetooth	Successful Bluetooth Connection
lb	Pound	Document	Data transmitting / pending to transmit to wireless wellness system
cm	Centimeter	Battery	Low Battery
kg	Kilogram		

♥ General Instructions

Transtek Body Fat Analyzer BF-1256-B1 applies BIA (Bio-impedance Analysis) technology. A small amount of weak current flows through the human body so as to detect the bio-impedance and estimate body fat, body water, muscle mass and bone mass. The electrical current is small and may not be felt.

This BIA technology is cheap, safe, non-invasive, toxic-free and harmless. It also possesses the characteristics of simple operation and abundant information.

The current mentioned above is less than 0.5mA. However, please be aware that anyone with an wearable or implantable medical electronic instrument, such as a pacemaker, must avoid using this device.

The intended use of this device is for healthy children 10-17 years old and healthy adults.

♥ Power Supply

Battery Mode: 6V, 4 x AAA batteries

Battery Life: Approx. 120 days

(Battery capacity: 230 mAh. If measured three times per day, each measurement takes about 46s.

The current for measurement is about 30 mA , while the current when shutdown is about 30 uA.)

♥ Insert the Batteries

- Open the battery door in the back of the scale.

- Insert the batteries (4 x 1.5V AAA) into the battery compartment according to the polarity indications marked inside the compartment.

* The digits "8888" will be shown on the LCD.



- Close the battery door and wait until the digits "00" are shown on the LCD.



CAUTION

- When the symbol  appears, the device will power off. Then you shall replace with a new set of batteries. Please replace all four batteries at the same time. Do NOT mix the old batteries with the new one.
- Worn batteries are hazardous waste. Do NOT dispose of them together with the household garbage.
- Please refer to the local ordinances and recycling instructions regarding disposal of the worn batteries and scrapped device.
- If you do not intend to use this unit for a prolonged period of time, it is advisable to remove the batteries before storing.

♥ Pair-Up

With the advanced Bluetooth 4.0 technology applied, the mobile or portable equipments, which are equipped with Bluetooth function in line with BLE Technical Specifications established by global organization Bluetooth SIG, are capable to receive your personal health data.

- Turn on Bluetooth and the App. Make sure both are ON when pair-up is proceeding.
- Press and hold "UNIT" button in the back of the scale to start pair-up.

Symbol  and symbol  will be shown on the LCD alternatively, indicating pair-up is proceeding.

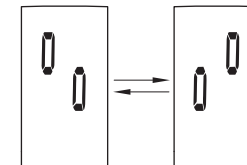

If SUCCEED, symbol [] will be shown on the LCD.

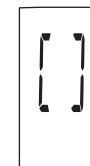

If FAIL, symbol "E1" will be shown on the LCD.



♥ Set Up Your Profile

The body fat analyzer BF-1256-B1 supports multiple users (Up to Eight). You may follow below instructions to assign User ID and set up your own profile, including Gender, Stature, and Age.

1. Assigning User ID

- With batteries correctly installed, press “SET” key to enter setting.
- The system will request User ID selection first. As pictured below, “P1” blinks. The operator may press the function key ◀ or ▶ to select User ID among P1 to P8.
- Press “SET” key to confirm User ID.

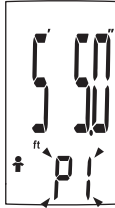

2. Setting Gender

- After confirming User ID, the system will divert to Gender setting automatically.
- As pictured below, the portrait ♀ blinks. The operator may press the function key ◀ or ▶ to select Gender.
- Press “SET” key to confirm Gender.
Note: The athlete mode is only available for those 15-85 years of age.

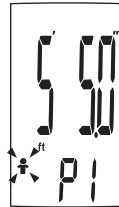

3. Setting Stature

- After confirming Gender, the system will divert to Stature setting automatically.
- As pictured below, the digits “5'5.0” blinks. The operator may press the function key ◀ or ▶ to increase or decrease the numeral. (Range: 100 cm to 220 cm/ 3'3.5”~7'2.5” ft)
- You may press and hold the function key ◀ or ▶ for fast changing the numeral.
- Press “SET” key to confirm Stature.



4. Setting Age

- After confirming Stature, the system will divert to Age setting.
- As pictured below, the digits “30” blinks. The operator may press the function key ◀ or ▶ to increase or decrease the numeral. (Range: 10 to 85 years old)
- You may press and hold the function key ◀ or ▶ for fast changing the numeral.
- Press “SET” key to confirm Age.

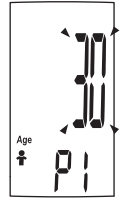

When the LCD displays “0.0”, you may start measuring.

♥ Select Measurement Unit

With batteries correctly installed, press “UNIT” button in the back of the scale to select measurement unit. The default measurement unit is “lb”. You may press “UNIT” button to choose among pound, kilogram and stone.

♥ Initialising Your Scale

1. Press the platform centre and remove your foot.
2. "0.0" will be displayed.



3. The scale will switch off and is now ready for use.
This initialisation process must be repeated if the scale is moved.
At all other times step straight on the scale.

♥ Weight Only Operation

Your TRANSTEK Body Fat Analyzer will operate as a conventional weight - reading scale. No special programming steps are required.

Once the scale is initialized, as previously described, you may simply step on the scale to measure your current weight. For only weight reading.

1. Position the scale on a flat, hard surface. Carpeted or uneven floors may affect accuracy.
2. Step onto the scale platform and remain still while the scale computes your weight.
3. The scale will display your weight value.

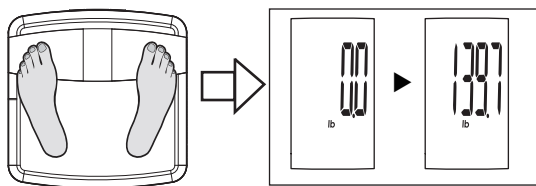

4. The scale will automatically turn off after a few seconds.

♥ First Measurement

- Please process the user setting before your first measurement.
(Refer to [Set Up Your Profile](#) for more details)

STEP 1: Step on the platform barefooted.

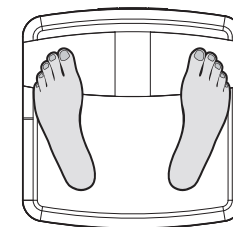

STEP 2: Stand still and keep full contact with the electrodes until the LCD stops displaying moving "o".

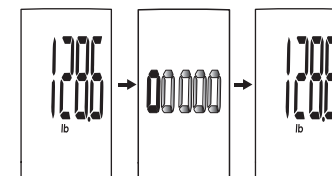

STEP 3: Then the measuring results will be displayed sequentially three times: Body Fat, Total Body Water, Muscle Mass, Bone Mass.

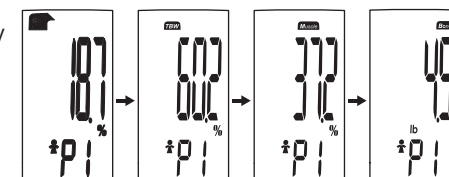

* If it fails to complete the analysis, the LCD will only display the weight data.

(To find out the solutions, please refer to [Troubleshooting](#) for more details.)

- When your scale is successfully paired with your smartphone and the Bluetooth is ON, BF-1256-B1 will process data transmission instead.

(Please refer to [Data Transmission](#) for more details.)

♥ Daily Measurement

- With original SENSE ON patent technology, BF-1256-B1 will automatically switch on as you step on the platform barefooted.

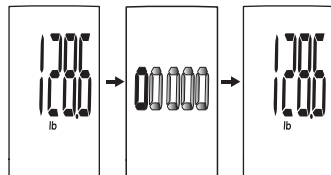

- Stand still and keep full contact with the electrodes until the LCD stops displaying moving “o”.

- According to the analysis results, the system will automatically identify the possible User ID with most similar history records. Then the measuring results will be displayed sequentially three times.

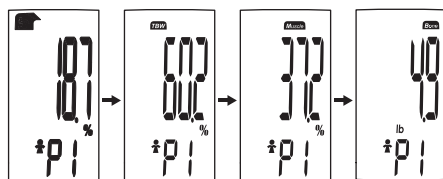

- When the system finds out two or more users with similar history records, it will notify you to choose between, for example, P1 and P2. You may press ◀ key for P1 and or ▶ key for P2. The measuring results will then be sorted into the User ID you selected and displayed sequentially three times.



- If it fails to identify the possible User ID, the LCD will only display the weight data.

(To find out the solutions, please refer to [Troubleshooting](#) for more details.)

- When your scale is successfully paired with your smartphone and the Bluetooth is ON, BF-1256-B1 will process data transmission instead.

(Please refer to [Data Transmission](#) for more details.)

♥ Body Fat Indicator

The Progress Bar at the top of the LCD Display also functions as the indicator of body fat level. When the measuring result is displayed after analysis, the varying length of the bar indicates different levels of body fat.

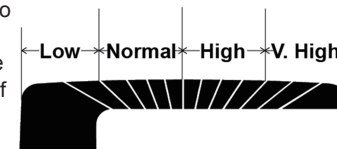

(Please refer to [Table of Body Fat Level](#) for more details.)

♥ Data Transmission

- With BF-1256-B1 successfully pair-up with your smartphone, the measurement data will be transmitted to your mobile via Bluetooth.
- ONLY when the measuring results are attached to a specific User ID will it be transmitted to your mobile after measurement.
- The symbol will disappear after successful data transmission, and you may check your personal health data stored in your smartphone.
- If the data transmission fails, the symbol will remain. The pending measurement data will be temporarily kept in the scale and transmitted to your smartphone when next measurement is complete.



	Successful Bluetooth Connection
	Data transmitting to wireless wellness system: -If SUCCEED, the symbol disappears; -If FAIL, the symbol remains.



CAUTION

- Interference may occur in the vicinity of equipment marked with the following symbol . And the Analyzer may interfere vicinity electrical equipment.
- To enable the data transmission function, this product should be paired to a Bluetooth 4.0 end.

How to mitigate possible interference?

1. The range between the Analyzer and the Bluetooth end should be reasonably close, from 1 meter to 10 meters. Please ensure no obstacles between the Analyzer and the Bluetooth end so as to obtain quality connection.
2. To avoid interference, other electronic devices (particularly those with Bluetooth transmission / Transmitter) should be kept at least 1 meter away from the Analyzer.

♥ Error Prompt

Error	Description	Solution
	Overload. The device will power off.	Stop using this scale for measurement.
	Low Battery. The device will power off.	Replace all four batteries at the same time. Please purchase the authorized batteries for replacement.
	Failure of pairing up your scale with your smartphone.	Please check below items: -Bluetooth is ON. -App Collector is ON. -Both devices are within the transmission distance of Bluetooth.

♥ When Measuring ...

Problem	Root Cause	Solution
Abnormal measuring results: - Too high; OR - Too low; OR - Huge difference between two recent measurement.	Incorrect posture	Please step on the platform barefooted and stand still.
	The device is located on the soft ground such as a carpet OR on a rugged surface.	Please place the device on a flat, hard surface.

Problem	Root Cause	Solution
Abnormal measuring results: - Too high; OR - Too low; OR - Huge difference between two recent measurement.	Either your hands or your feet are too dry.	Wipe your feet with a damp cloth, keeping them slightly damp when starting measurement.
No display on LCD when the device powers on.	Batteries not yet installed.	Install the batteries. (Please refer to Insert the Batteries)
	Worn batteries.	Replace all four batteries at the same time. Please purchase the authorized batteries for replacement.
CANNOT proceed to analyze body fat, total body water, muscle mass and bone mass.	Step onto the platform wearing socks or shoes.	Please keep barefooted during the measurement, and keep full contact with the electrodes as well.
	The system cannot identify the possible User ID with most similar data.	Please assign a User ID following the instruction in Set Up Your Profile .
	The user fails to select the User ID from what the system found.	Please assign a User ID following the instruction in Set Up Your Profile .
The device powers off.	Low battery.	Replace all four batteries at the same time. Please purchase the authorized batteries for replacement.

♥ When Data Transmitting ...

Problem	Root Cause	Solution
Data transmission failed.	Bluetooth is OFF.	Turn ON the Bluetooth via "Setting >> General >> Bluetooth".
	The App is OFF.	Press the icon to turn ON your app.
	Out of range of Bluetooth transmission.	Place your smartphone closer to the scale.
	None of the user ID is assigned.	Please assign a User ID following the instruction in Set Up Your Profile .

♥ Specifications

Product Name	Body Fat Analyzer (BF-1256-B1)
Dimension	Scale: 310x310x29mm (Approximately)
Net Weight	Approximately 1.6kg (Excluding the dry cells)
Display	Digital LCD with White Backlight
Measurement Unit	Kilogram / Stone/ Pound
Measurement Range	5kg to 200kg / 0st: 11lb to 31st: 7lb / 11lb to 441lb
Division	0.1kg / 0.2lb
Accuracy	5-50kg: ±0.3kg; 50-100kg: ±0.4kg; 100-150kg: ±0.5kg; 150-200kg: ±0.7kg
Working Environment	Temperature: 5°C to 40°C Humidity: ≤90% RH Atmospheric pressure: 80kPa to 106kPa
Storage Environment	Temperature: -20°C to 60°C Humidity: ≤93% RH Atmospheric pressure: 50kPa to 106kPa
Power Source	6V (Four AAA-size Batteries)
Turn on Method	SENSE ON technology
Auto-OFF	The scale will turn off after about 10 seconds if there is no operation
Accessories	1. Four AAA-size batteries 2. User Manual
Mode of Operation	Continuous Operation
Degree of protection	Type BF applied part
Protection against ingress of water	IP21, It means the device could protected against solid foreign objects of 12.5 mm and greater, and against vertically falling water drops
Protection Against Ingress of Water	IPX0
Software Version	1.0
Bluetooth Module No.	AW8001

♥ Maintenance

When carrying out usual maintenance, please ensure practice of the following Do's and Don'ts:

- DO use a dry soft cloth to wipe the dust.
- DO use a wet soft cloth, dipped into water and wrung out, to wipe the dirt. Then use a dry soft cloth to dry up the device.
- DON'T wash the device with water or immerse it in water.
- DON'T use propellant, abrasive or other chemicals to wipe the dirt in avoidance of discolor or malfunction.
- DON'T disassemble this device. If you have any problems, please contact Transtek.
(Please refer to *Warranty* for contact information)
- Do not dispose of batteries in fire. Batteries may explode or leak. Remove the batteries if the scale will not be used for a long period.

♥ Warranty

- Transtek warrants its products free of defects in materials and workmanship in normal use for a period of FIVE years from the date of retail purchase.
- This warranty does NOT cover damages caused by misuse or abuse, including but not limited to:
Failure caused by unauthorized repairs or modifications;
Damage caused by shock or drop during transportation;
Failure caused by improper operation inconsistent with the instructions stated in this user manual;
Malfunction or damage from failure to provide the recommended maintenance;
Damage caused by improper use of power supply.
- Should this device require maintenance (or replacement at our option) under warranty, please deliver the original package to GUANGDONG TRANSTEK MEDICAL ELECTRONICS CO., LTD prepaid. Please return the store receipt (with the retail purchase date) and a note with reasons to return on it as well.

GUANGDONG TRANSTEK MEDICAL ELECTRONICS CO., LTD
Zone A, 5/F., Investment Building, No. 12 Huizhan East Rd., Torch Development District,
Zhongshan, 528437, Guangdong, China
Tel: 86-760-88282982
Website: <http://www.transtek.cn>

♥ FCC Regulations

FCC User Guide Information

Radio Frequency Interface Requirements - FCC

Note: This equipment has been tested and found to comply with the limits for a Class B digital device, pursuant to Part 15 of the FCC rules. These limits are designed to provide reasonable protection against harmful interference in a residential installation. This equipment generates, uses and can radiate radio frequency energy and, if not installed and used in accordance with the instructions, may cause harmful interference to radio communications. However there is no guarantee that interference will not occur in a particular installation. If this equipment does cause harmful interference to radio or television reception, which can be determined by turning the equipment off and on, the user is encouraged to try to correct the interference by one or more of the following measures:

- Reorient or relocate the receiving antenna;
- Increase the separation between the equipment and receiver;
- Connect the equipment into an outlet on a circuit different from that to which the receiver is connected;
- Consult the dealer or an experienced radio / TV technician for help.

Radio Transmitters (Part 15)

This device complies with Part 15 of the FCC Rules. Operation is subject to the following two conditions: (1) this device may not cause harmful interference, and (2) this device must accept any interference received, including interference that may cause undesired operation.

Changes or modifications not expressly approved by the party responsible for compliance could void the user's authority to operate the equipment.

FCC RF Exposure Guidelines

Safety Information

Reducing RF Exposure - Use Properly

Only operate the device in accordance with the instructions supplied.

This device complies with FCC radiation exposure limits set forth for an uncontrolled environment.

♥ Table of Body Fat Level (Unit: %)

a) The body fat percentage (%): 5%-60%/0.1%

Standard for Men

Standard for Women

Rating	Age					Rating	Age				
	20-29	30-39	40-49	50-59	60+		20-29	30-39	40-49	50-59	60+
low	<13	<14	<16	<17	<18	low	<19	<20	<21	<22	<23
Normal	14-20	15-21	17-23	18-24	19-25	Normal	20-28	21-29	22-30	23-31	24-32
Moderately High	21-23	22-24	24-26	25-27	26-28	Moderately High	29-31	30-32	31-33	32-33	33-35
High	>23	>24	>26	>27	>28	High	>31	>32	>33	>34	>35

Source: University of Illinois Department of Food Science and Human Nutrition.
Body Fat Percentage Calculator.

www.ag.uiuc.edu/~food-lab/ai/bfc.html

♥ Table of Body Water Level (Unit: %)

b) The body water percentage (%): 43%-73%/0.1%

Source: Derived from Wang & Deurenberg: "Hydration of fat-free body mass". American Journal Clin Nutr 1999,69833-841.

	BF % RANGE	OPTIMAL TBW % RANGE
Men	4 to 14%	70 to 63%
	15 to 21%	63 to 57%
	22 to 24%	57 to 55%
	25 and over	55 to 37%
Women	4 to 20%	70 to 58%
	21 to 29%	58 to 52%
	30 to 32%	52 to 49%
	33 and over	49 to 37%

♥ Muscle Mass Percentage

(Source: International Commission on Radiological Protection,1975)

Men	Approximately 40% of total body weight
Women	Approximately 30% of total body weight

♥ Bone Mass Percentage

(Source: Rico et al.1993)

The average bone mass percentage for both men and women is between 4 to 5%.

♥ Health Tips - About Body Fat

Fat is essential for human body. It can not only store energy and protect viscera, but also regulate body temperature and maintain normal physiological function of human body. However, too much body fat is harmful to human body. It is always accompanied by Fatty Liver, diabetes, coronary heart disease, etc.

Therefore self-measuring and self-monitoring body fat level are beneficial to your health. Since we can't judge body fat level simply by our weight, this body fat analyzer BF-1256-B1, with BIA (Bio-impedance Analysis) technology applied, is an accurate device that offers a quick and comfortable way to obtain your body fat level.

♥ EMC Guidance

1. MEDICAL ELECTRICAL EQUIPMENT needs special precautions regarding EMC and needs to be installed and put into service according to the EMC information provided in the ACCOMPANYING DOCUMENTS.
2. Wireless communications equipment such as wireless home network devices, mobile phones, cordless telephones and their base stations, walkie-talkies can affect this equipment and should be kept at least a distance $d = 3,3$ m away from the equipment. (Note. As indicated in Table 6 of IEC 60601-1-2:2007 for ME EQUIPMENT, a typical cell phone with a maximum output power of 2 W yields $d = 3,3$ m at an IMMUNITY LEVEL of 3 V/m)

Table 1 – Guidance and MANUFACTURER'S declaration – ELECTROMAGNETIC EMISSIONS for all ME EQUIPMENT and ME SYSTEMS

Guidance and manufacturer's declaration – electromagnetic emissions		
The device is intended for use in the electromagnetic environment specified below. The customer or the user of the device should assure that it is used in such an environment.		
Emissions test	Compliance	Electromagnetic environment-guidance
RF emissions CISPR 11	Group 1	The device must emit electromagnetic energy in order to perform its intended function. Nearby electronic equipment may be affected.
RF emissions CISPR 11	Class B	
Harmonic emissions IEC 61000-3-2	Not applicable	
Voltage fluctuations/ flicker emissions IEC 61000-3-3	Not applicable	

Table 2 – Guidance and MANUFACTURER'S declaration – electromagnetic IMMUNITY – for all ME EQUIPMENT and ME SYSTEMS

Guidance and manufacturer's declaration – electromagnetic immunity			
The device is intended for use in the electromagnetic environment specified below. The customer or the user of the device should assure that it is used in such an environment.			
IMMUNITY test	IEC 60601 test level	Compliance level	Electromagnetic environment – guidance
Electrostatic discharge (ESD) IEC 61000-4-2	± 6 kV contact ± 8 kV air	± 6 kV contact ± 8 kV air	Floors should be wood, concrete or ceramic tile. If floors are covered with synthetic material, the relative humidity should be at least 30 %.
Electrical fast transient/burst IEC 61000-4-4	± 2 kV for power supply lines ± 1 kV for input/output lines	Not applicable	Mains power quality should be that of a typical commercial or hospital environment.
Surge IEC 61000-4-5	± 1 kV line(s) to line(s) ± 2 kV line(s) to earth	Not applicable	Mains power quality should be that of a typical commercial or hospital environment.
Voltage dips, short interruptions and voltage variations on power supply input lines IEC 61000-4-11	<5 % U_T (>95 % dip in U_T) for 0,5 cycle 40 % U_T (60 % dip in U_T) for 5 cycles 70 % U_T (30 % dip in U_T) for 25 cycles <5 % U_T (>95 % dip in U_T) for 5 s	Not applicable	Mains power quality should be that of a typical commercial or hospital environment. If the user of the device requires continued operation during power mains interruptions, it is recommended that the device be powered from an uninterruptible power supply or a battery.
Power frequency (50/60 Hz) magnetic field IEC 61000-4-8	3 A/m	3 A/m	Power frequency magnetic fields should be at levels characteristic of a typical location in a typical commercial or hospital environment.
NOTE U_T is the a.c. mains voltage prior to application of the test level.			

Table 4 – Guidance and MANUFACTURER'S declaration – electromagnetic IMMUNITY – for ME EQUIPMENT and ME SYSTEMS that are not LIFE-SUPPORTING

Guidance and manufacturer's declaration – electromagnetic immunity			
The device is intended for use in the electromagnetic environment specified below. The customer or the user of the device should assure that it is used in such an environment.			
IMMUNITY test	IEC 60601 TEST LEVEL	Compliance level	Electromagnetic environment – guidance
Conducted RF IEC 61000-4-6	3 Vrms 150 kHz to 80 MHz	Not applicable	Portable and mobile RF communications equipment should be used no closer to any part of the device, including cables, than the recommended separation distance calculated from the equation applicable to the frequency of the transmitter. Recommended separation distance $d = \left[\frac{3.5}{f_1} \right] \sqrt{P}$
Radiated RF IEC 61000-4-3	3 V/m 80 MHz to 2.5 GHz	3 V/m	$d = 1.167 \sqrt{P}$ 80 MHz to 800 MHz $d = 2.333 \sqrt{P}$ 800 MHz to 2.5 GHz where P is the maximum output power rating of the transmitter in watts (W) according to the transmitter manufacturer and d is the recommended separation distance in metres (m). Field strengths from fixed RF transmitters, as determined by an electromagnetic site survey, ^a should be less than the compliance level in each frequency range. ^b Interference may occur in the vicinity of equipment marked with the following symbol: 
NOTE 1 At 80 MHz and 800 MHz, the higher frequency range applies.			
NOTE 2 These guidelines may not apply in all situations. Electromagnetic propagation is affected by absorption and reflection from structures, objects and people.			
a Field strengths from fixed transmitters, such as base stations for radio (cellular/cordless) telephones and land mobile radios, amateur radio, AM and FM radio broadcast and TV broadcast cannot be predicted theoretically with accuracy. To assess the electromagnetic environment due to fixed RF transmitters, an electromagnetic site survey should be considered. If the measured field strength in the location in which the device is used exceeds the applicable RF compliance level above, the device should be observed to verify normal operation. If abnormal performance is observed, additional measures may be necessary, such as re-orienting or relocating the device.			
b Over the frequency range 150 kHz to 80 MHz, field strengths should be less than [f_1] V/m.			

Table 6 – Recommended separation distances between portable and mobile RF communications equipment and the ME EQUIPMENT or ME SYSTEM – for ME EQUIPMENT and ME SYSTEMS that are not LIFE-SUPPORTING

Recommended separation distances between portable and mobile RF communications equipment and the device			
The device is intended for use in an electromagnetic environment in which radiated RF disturbances are controlled. The customer or the user of the device can help prevent electromagnetic interference by maintaining a minimum distance between portable and mobile RF communications equipment (transmitters) and the device as recommended below, according to the maximum output power of the communications equipment.			
Rated maximum output power of transmitter W	Separation distance according to frequency of transmitter m		
	150 kHz to 80 MHz $d = \left\lceil \frac{35}{V_1} \right\rceil \sqrt{P}$	80 MHz to 800 MHz $d = 1.167 \sqrt{P}$	800 MHz to 2,5 GHz $d = 2.333 \sqrt{P}$
0,01	Not applicable	0.117	0.233
0,1	Not applicable	0.369	0.738
1	Not applicable	1.167	2.333
10	Not applicable	3.690	7.378
100	Not applicable	11.67	23.33
For transmitters rated at a maximum output power not listed above, the recommended separation distance d in metres (m) can be estimated using the equation applicable to the frequency of the transmitter, where P is the maximum output power rating of the transmitter in watts (W) according to the transmitter manufacturer.			
NOTE 1 At 80 MHz and 800 MHz, the separation distance for the higher frequency range applies.			
NOTE 2 These guidelines may not apply in all situations. Electromagnetic propagation is affected by absorption and reflection from structures, objects and people.			