



---

# On-Board Validator Manual

---

Version	Author	Approval date	Approved by	Change	DRN/DCN Number
A	A. Pasker			Initial Release	

---

## Contents

1	Overview.....	4
2	References .....	4
3	Acronyms.....	4
4	Electromagnetic Specifications .....	5
5	Environmental.....	6
5.1	Temperature .....	6
5.2	Shock and Vibration.....	6
5.3	Electrostatic Discharge .....	6
5.4	MTBF.....	6
5.5	Power Input.....	6
5.6	Mechanical .....	6
6	Connectors .....	7
6.1	Power .....	7
6.1.1	Connector .....	7
6.1.2	Pinout .....	7
6.2	Digital Input.....	7
6.2.1	Connector .....	7
6.2.2	Pinout .....	7
6.3	J1708.....	7
6.3.1	Connector .....	7
6.3.2	Pinout .....	7
6.4	Ethernet.....	9
6.4.1	Connector .....	9
6.4.1	Pinout .....	9
7	Card Interfaces .....	9
7.1	Micro-SD Card Slot.....	9
7.2	SIM Card Slot .....	9
7.3	SAM Card Slots .....	9
8	Interface Specifications/Recommendations.....	9
8.1	J1708.....	9



---

8.2	Digital Inputs .....	10
8.3	Audio .....	10
8.4	GPS .....	10
8.5	Wi-Fi .....	11
8.6	Ethernet .....	11

## 1 Overview

This document is to provide the specifications and recommendations for the interconnection of the EzeFare Validator.

## 2 References

- [1] SAE J1708 Serial Data Communication Between Microcomputer Systems in Heavy-Duty Vehicle Applications Aug 2004
- [2] SAE 1939-11 Physical Layer, 250K bits/s, Twisted Shielded Pair Oct 1999
- [3] Telit Jupiter JF2 Datasheet
- [4] IEEE 802.3

## 3 Acronyms

Acronym	Meaning
DC	Direct Current
EMI	Electromagnetic Interference
FCC	Federal Communications Commission
GPS	Global Positioning System
IEEE	Institute of Electrical and Electronic Engineers, Inc.
LAN	Local Area Network
MTBF	Mean Time Before Failure
RMS	Root mean square
USB	Universal Serial Bus
Wi-Fi	Wireless network based on IEEE 802.11

---

## 4 Electromagnetic Specifications

Note: This equipment has been tested and found to comply with the limits for a Class A digital device, pursuant to Part 15 of the FCC Rules. These limits are designed to provide reasonable protection against harmful interference in a residential installation. This equipment generates, uses and can radiate radio frequency energy and, if not installed and used in accordance with the instructions, may cause harmful interference to radio communications. However, there is no guarantee that interference will not occur in a particular installation. If this equipment does cause harmful interference to radio or television reception, which can be determined by turning the equipment off and on, the user is encouraged to try to correct the interference by one or more of the following measures:

- Reorient or relocate the receiving antenna.
- Increase the separation between the equipment and receiver.
- Connect the equipment into an output on a circuit different from that to which the receiver is connected.
- Consult the dealer or an experienced radio/TV technician for help.



*Changes or modifications not expressly approved by the manufacturer could void the user's authority to operate the equipment.*

This device complies with Industry Canada licence-exempt RSS standard(s). Operation is subject to the following two conditions: (1) this device may not cause interference, and (2) this device must accept any interference, including interference that may cause undesired operation of the device.

Le présent appareil est conforme aux CNR d'Industrie Canada applicables aux appareils radio exempts de licence. L'exploitation est autorisée aux deux conditions suivantes : (1) l'appareil ne doit pas produire de brouillage, et (2) l'utilisateur de l'appareil doit accepter tout brouillage radioélectrique subi, même si le brouillage est susceptible d'en compromettre le fonctionnement.

---

## 5 Environmental

The EzeFare Validator is designed to meet the following specifications but is not tested to meet SAE J1455.

### 5.1 Temperature

Operating: -20°C - + 60°C

Storage: -30°C - +70°C

### 5.2 Shock and Vibration

Swept Sinusoidal: 10 – 2000 Hz @ 2 g

Survive and impact velocity of 1.75 m/s on all edges and corners

### 5.3 Electrostatic Discharge

Packaging and Handling: Tested to +/- 4kV direct contact discharge.

In-Vehicle Operation: Tested to +/- 8kV direct contact discharge.

### 5.4 MTBF

50K hours MTBF minimum

### 5.5 Power Input

Operating voltage range: 8 – 36V DC

Current: Nominal value 500 mA @ 12V, 250 mA @ 24V

Peak value 2 A @ 12V, 1A @ 24V

Overvoltage (>36V) and reverse voltage protected.

### 5.6 Mechanical

Depth: 81 mm (3.19")

Width: 134 mm (5.28")

Length: 213 mm (8.39")

## 6 Connectors

### 6.1 Power

#### 6.1.1 Connector

Connector: Molex 0306-2044

Mating Connector: Molex 0306-1043 or equivalent

#### 6.1.2 Pinout

Pin Number	Signal	Signal Type
1	VIN	Vehicle Battery +
2	GND	Chassis Ground
3	IGN_SENSE	Vehicle Ignition Sense
4	RFU	Reserved For Future Use

### 6.2 Digital Input

#### 6.2.1 Connector

Connector: Unterminated

#### 6.2.2 Pinout

Pin Number	Signal	Signal Type
1	INPUT1	Discrete Input
2	INPUT2	Discrete Input
3	INPUT3	Discrete Input
4	INPUT4	Discrete Input
5	INPUT5	Discrete Input

### 6.3 J1708

#### 6.3.1 Connector

Connector: Molex 0306-2032

Mating Connector: Molex 0306-1038 or equivalent

#### 6.3.2 Pinout

Pin Number	Signal	Signal Type
1	J1708A	J1708A(-)



Pin Number	Signal	Signal Type
2	N/C	N/A
3	J1708B	J1708B(+)



## 6.4 Ethernet

### 6.4.1 Connector

Connector: D-SUB 50 Male

Mating Connector: D-SUB 50 Female, AMP 1658641-3 or equivalent

### 6.4.1 Pinout

Pin Number	Signal	Signal Type
1	TPI+	Data In+
2	TPI-	Data In-
3	TPO-	Data Out-
4	TPO+	Data Out+
5	SHIELD	Ground

## 7 Card Interfaces

### 7.1 Micro-SD Card Slot

One MicroSD card slot for removable memory storage.

### 7.2 SIM Card Slot

One Mini-SIM (2FF) card slot.

### 7.3 SAM Card Slots

Two Secure Access Module card (2FF) slots.

## 8 Interface Specifications/Recommendations

### 8.1 J1708

J1708 is a modified version of RS-485. J1708 specifies 18 gauge wire with 1 twist per inch with a total network length of 131 feet (40m) maximum. The minimum/maximum voltages on the bus are specified to be -7V – +12V. The data rate is 9600 baud. The standard node in the J1708 standard is shown in Figure 8-1.

Vdiff is defined as A – B. If  $A - B \geq 200$  mV then the data bit is a 1,  $-200$  mV  $\leq A - B \leq 200$  mV is undefined,  $A - B \leq -200$ mV the data bit is a 0.

**SERIAL DATA BUS STANDARD NODE (UNIPOLAR DRIVE WITH PASSIVE TERMINATION IN EACH MODULE)**

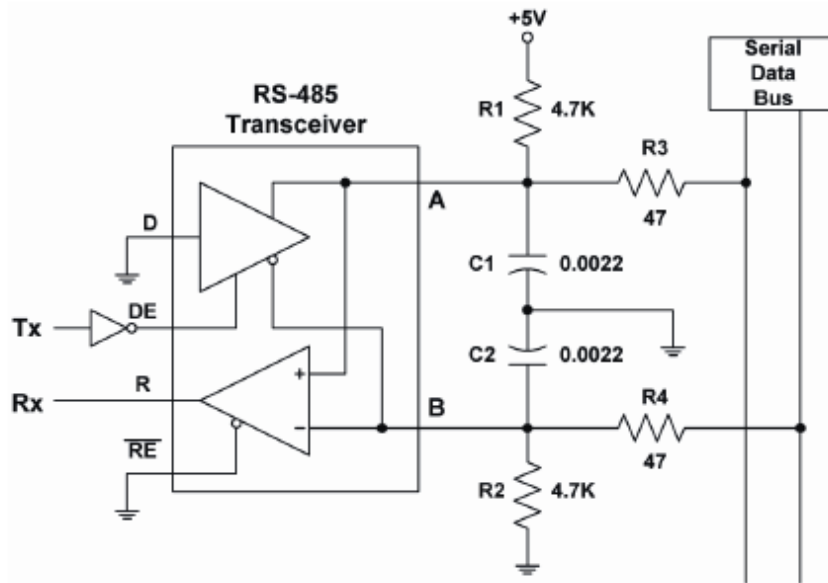

Figure 8-1

Note: C1 and C2 are 0.0022  $\mu$ F.

Caution: An RS-485 specified termination uses a 100 ohm resistors external to each node at each end of the bus which if installed in a J1708 system can cause the network to fail/

## 8.2 Digital Inputs

$V_{IL} < 0.5V$  and  $V_{IH} 1.2V$ .

These inputs are protected with 47K of series resistance. Transients to 60V can be tolerated with circuit damage becoming more likely above 60V.

## 8.3 Audio

The speaker is rated to 3W, 200 – 20,000 Hz.

## 8.4 GPS

The On-Board Validator uses an internal GPS antenna. Specifications taken from Telit Jupiter JF2 Datasheet [3].

Channels	48
Sensitivity	To -163 dBm



Heading	0.01 deg
Velocity	0.01 m/s
Accuracy	2.5 m
Acquisition Rate	Cold start: 35s, average Hot start: 1s, average
Protocol	NMEA and OSP

## 8.5 Wi-Fi

The EzeFare Validator uses an internal Wi-Fi module and antenna. This supports 802.11 b/g/n and WPA2 encryption.

## 8.6 Ethernet

There is one 10/100 BASET port. Full details of the physical layer are found in the IEEE 802.3 Specification [4].