



TY91/TY92 VHF radio Installation Manual



00839-00-AA
11 April 2012

Trig Avionics Limited
Heriot Watt Research Park
Riccarton, Edinburgh
EH14 4AP
Scotland, UK

Copyright Trig Avionics Limited, 2012

This page intentionally left blank

CONTENTS

1. PREFACE.....	5
1.1 PURPOSE	5
1.2 SCOPE	5
1.3 CHANGES FROM PREVIOUS ISSUE.....	5
1.4 DOCUMENT CROSS-REFERENCES.....	5
2. INTRODUCTION.....	7
2.1 TY91/TY92 DESCRIPTION.....	7
2.2 INTERFACES	7
2.2.1 <i>TY91/TY92 VHF radio Unit</i>	7
2.2.2 <i>TC90 Controller Unit</i>	8
3. TECHNICAL SPECIFICATIONS.....	9
3.1 TY91 VHF RADIO UNIT (00882-00-01)	9
3.2 TY92 VHF RADIO UNIT (00879-00-01)	10
3.3 TC90 CONTROL UNIT (00857-00-01)	11
3.4 LOW VOLTAGE OPERATION	12
3.5 INSTALLATION APPROVAL.....	13
4. UNIT AND ACCESSORIES SUPPLIED.....	14
4.1 TY91 VHF RADIO ITEMS	14
4.2 TY92 VHF RADIO ITEMS	14
4.3 TC90 CONTROLLER ITEMS.....	14
4.4 INSTALLATION KIT	14
4.5 REQUIRED ITEMS	15

5.	INSTALLATION	16
5.1	UNPACKING AND INSPECTING EQUIPMENT	16
5.2	CONTROLLER MOUNTING	16
5.3	VHF RADIO MAIN UNIT MOUNTING	17
5.4	COOLING REQUIREMENTS	17
5.5	TY91/TY92 VHF RADIO ELECTRICAL CONNECTIONS	18
5.5.1	<i>TY91/TY92 Interface – Pinout</i>	18
5.6	TY91/TY92 VHF RADIO INTERFACE DETAILS	19
5.6.1	<i>Speaker Output</i>	19
5.6.2	<i>TMAP Bus</i>	19
5.6.3	<i>Headphone Output</i>	20
5.6.4	<i>Controller Power</i>	20
5.6.5	<i>Power On</i>	20
5.6.6	<i>PTT1/2 Key Input</i>	20
5.6.7	<i>Intercom Key Input</i>	21
5.6.8	<i>Transmit Interlock</i>	21
5.6.9	<i>Auxiliary Audio Input</i>	21
5.6.10	<i>Microphone Input</i>	22
5.6.11	<i>Power Input</i>	22
5.6.12	<i>Ground Returns</i>	22
5.7	TC90 CONTROLLER ELECTRICAL CONNECTIONS	22
5.7.1	<i>TC90 Interface - Pinout</i>	23
5.8	TC90 CONTROLLER INTERFACE DETAILS	24
5.8.1	<i>TMAP Bus</i>	24

5.8.2	<i>RS232 Input</i>	24
5.8.3	<i>Remote ON</i>	24
5.8.4	<i>Power</i>	24
5.8.5	<i>Step Button</i>	24
5.8.6	<i>Transfer Button</i>	25
5.9	D CONNECTOR CRIMP TERMINALS.....	25
5.10	WIRING CONSIDERATIONS.....	26
5.10.1	<i>TC90 Interconnect</i>	26
5.10.2	<i>Audio wiring</i>	27
5.11	ANTENNA INSTALLATION.....	27
5.11.1	<i>Antenna Ground Plane</i>	28
5.11.2	<i>Antenna Cable</i>	29
5.11.3	<i>TNC Connector</i>	29
6.	INSTALLATION SETUP AND TEST	31
6.1	INITIAL POWER ON.....	31
6.2	CONFIGURATION ITEMS.....	31
6.2.1	<i>Intercom Volume</i>	31
6.2.2	<i>Intercom Squelch</i>	32
6.2.3	<i>Auxiliary Input Volume</i>	32
6.2.4	<i>Auxiliary Input Muting</i>	32
6.2.5	<i>Sidetone Volume</i>	32
6.2.6	<i>Frequency Step Size</i>	33
7.	POST INSTALLATION CHECKS	34
8.	NORMAL OPERATION	35

8.1	OVERVIEW	35
8.2	DISPLAY	35
8.3	ON/OFF VOLUME KNOB	35
8.4	TUNING KNOBS	36
8.5	FLIP-FLOP BUTTON	36
8.6	MON BUTTON	36
8.7	MEM BUTTON	36
8.8	GENERAL LOW TEMPERATURE OPERATION	37
8.9	WARNING MESSAGES	37
8.10	FAULT ANNUNCIATION	37
9.	CONTINUED AIRWORTHINESS	39
10.	LIMITED WARRANTY	40
11.	ENVIRONMENTAL QUALIFICATION FORMS	41
12.	INSTALLATION DRAWINGS	47
12.1	MOUNTING TRAY FIXING AND OVERALL DIMENSIONS	47
12.2	FRONT PANEL CONTROLLER DIMENSIONS	48
12.3	FRONT PANEL CUT-OUT OPTIONS	49
13.	WIRING DIAGRAMS	51

1. Preface

1.1 Purpose

This manual describes the physical and electrical characteristics and the installation requirements for a TY91/TY92 VHF radio and associated controller.

1.2 Scope

This document applies to the installation of the TY91 and TY92 VHF radio.

At the publication date of this manual the software version identifier for the TY91/TY92 is 1.0 and the FPGA version identifier is 1.0. The TC90 controller software version identifier is 1.0. The software and FPGA versions are subject to change without notice.

1.3 Changes from Previous Issue

None – this is the first issue.

1.4 Document Cross-References

00840-00	TY91 VHF radio Operating Manual	AA
ETSO 2C169a	VHF Radio communication receiving equipment operating within the radio frequency range 117.875 – 137 MHz	EASA
TSO C169a	Minimum Operational Performance standards for Airborne Radio Communications equipment standards	FAA
ETSO 2C128	Devices that prevent blocked channels used in two-way radio communications due to unintentional transmissions	EASA

TSO C128a Equipment that prevents blocked channels used in FAA
two-way radio communications due to
unintentional transmissions

2. Introduction

2.1 TY91/TY92 Description

The TY91/TY92 VHF radio system is an ED-23C compliant class C (25 kHz offset carrier) and class E (8.33 kHz single carrier) VHF radio. The TY91 has a nominal power output of 6 watts, and meets the power output requirements for Class 4 and Class 6. The TY92 has a nominal power output of 16 watts, and meet the power output requirements for Class 3 and Class 5. The TY91/TY92 is certified to ETSO 2C169a 2C128a, TSO C169a and TSO C128a.

The TY91 and TY92 VHF radios are controlled using a separate front panel controller, called the TC90. This allows the radio to be mounted separately from the instrument panel, and reduces the amount of panel space taken by the VHF radio. The TC90 is certified to ETSO 2C169a, and TSO C169a.

The TY91 runs from either 14 volt nominal or 28 volt nominal DC power supply with no configuration changes required. The TY92 requires 28 volt nominal supply.

2.2 Interfaces

2.2.1 TY91/TY92 VHF radio Unit

The main VHF radio unit has a single TNC antenna connection and a single 25 way D-type connector. The 25 way D-type interface provides the following services:

Power Input	The TY91 operates on 11 to 33 volts DC. The TY92 operates on 22 to 33 volts DC.
Front Panel Datalink	A two wire data link is used to connect the TY91/TY92 and the controller.
Front Panel Power	The controller is powered from the VHF radio.

Remote On/Off	The on-off switching is on the controller, and switches this input.
Microphone inputs	There are two microphone inputs, suitable for conventional aircraft microphones.
Push-to-talk inputs	There are two push to talk inputs corresponding to the two microphones.
Headphone output	A headphone output suitable for conventional aircraft headsets with impedance in the region of 150 ohms.
Speaker output	A speaker output suitable for a cabin speaker with impedance of 4 ohms or greater.
Intercom keyswitch	An optional input to allow the intercom to be switch controlled.
Auxilliary audio input	A single connection to allow audio annunciators or ident tones to be routed to the headphones and speaker.

2.2.2 TC90 Controller Unit

The TC90 controller has a single 15 way D-type connector. It provides the following services:

Power Input	The controller receives power from the VHF radio.
Front Panel Datalink	A two wire data link is used to connect the TY91/TY92 and the controller.
Remote On/Off	The on-off switching is on the controller, and controls this output.
External switch inputs	Optional keyswitch inputs to enable remote transfer and frequency stepping
Serial input	Optional input to allow preloading of frequencies, generally from a GPS.

3. Technical Specifications

3.1 TY91 VHF Radio Unit (00882-00-01)

Specification	Characteristics
Compliance	ETSO 2C169a Class C, E, 4, 6, ETSO 2C128, TSO C169a Class C, E, 4, 6, TSO C128a
FCC Identification	VZI00882
Applicable documents	EUROCAE ED-23C, EUROCAE ED-67, EUROCAE ED-14F (RTCA DO-160F), RTCA DO-186B, RTCA DO-207
Software	ED-12B (RTCA DO-178B) Level B
Hardware	DO-254 Level C
Power Requirements	11 – 33 volts DC. Typical 2.8 watts @ 14volts, receive; typical 28 watts @ 14 volts, transmit. Maximum current 3.2A.
Altitude	55,000 feet
Humidity	95% @ +50°C for 6 hours; 85% @ +38°C for 16 hours. Tested to Category A in DO-160F
Operating Temperature	-20°C to +70°C
Transmitter Frequency	118.000 MHz to 136.992 MHz; 760 channels at 25 kHz spacing, 2280 channels at 8.33 kHz spacing.
Transmitter Power	6 watts nominal carrier power
Transmitter Modulation	5K6 A3E
Stuck-mic timeout	35 seconds

Transmitter Duty Cycle	100% transmit is possible (subject to stuck mic timeout)
Receiver Frequency	118.000 MHz to 136.992 MHz; 760 channels at 25 kHz spacing, 2280 channels at 8.33 kHz spacing.
Receiver Sensitivity	< 5uV for 6 dB SINAD
AGC Characteristic	< 6dB variation 5 uV to 100 mV EMF
Physical Specifications (in the mounting tray)	
Height	48mm (1.9")
Width	66mm (2.5")
Length	160mm (6.3")
Weight	0.77lbs. (350 g)

3.2 TY92 VHF Radio Unit (00879-00-01)

Specification	Characteristics
Compliance	ETSO 2C169a Class C, E, 3, 5, ETSO 2C128, TSO C169a Class C, E, 3, 5, TSO C128a
FCC Identification	VZI00879
Applicable documents	EUROCAE ED-23C, EUROCAE ED-67, EUROCAE ED-14F (RTCA DO-160F), RTCA DO-186B, RTCA DO-207
Software	ED-12B (RTCA DO-178B) Level B
Hardware	DO-254 Level C
Power Requirements	22 – 33 volts DC. Typical 2.8 watts @ 28volts, receive; typical 80 watts @ 28 volts, transmit. Maximum current 3.2A.
Altitude	55,000 feet

Humidity	95% @ +50°C for 6 hours; 85% @ +38°C for 16 hours. Tested to Category A in DO-160F
Operating Temperature	-20°C to +55°C
Transmitter Frequency	118.000 MHz to 136.992 MHz; 760 channels at 25 kHz spacing, 2280 channels at 8.33 kHz spacing.
Transmitter Power	16 watts nominal carrier power
Transmitter Modulation	5K6 A3E
Stuck-mic timeout	35 seconds
Tranmitter Duty Cycle	50% duty cycle – 35 seconds on followed by 35 seconds off.
Receiver Frequency	118.000 MHz to 136.992 MHz; 760 channels at 25 kHz spacing, 2280 channels at 8.33 kHz spacing.
Receiver Sensitivity	< 5uV for 6 dB SINAD
AGC Characteristic	< 6dB variation 5 uV to 100 mV EMF
Physical Specifications (in the mounting tray)	
Height	48mm (1.9")
Width	66mm (2.5")
Length	160mm (6.3")
Weight	0.77lbs. (350 g)

3.3 TC90 Control Unit (00857-00-01)

Specification	Characteristics
Compliance	ETSO 2C169a, TSO C169a

Applicable documents	EUROCAE ED-23C, EUROCAE ED-14F (RTCA DO-160F), RTCA DO-186B
Software	ED-12B (RTCA DO-178B) Level B
Altitude	35,000 feet
Humidity	95% @ +50°C for 6 hours; 85% @ +38°C for 16 hours. Tested to Category A in DO-160F
Operating Temperature	-20°C to +55°C
Physical Specifications (behind the panel)	
Height	44mm (1.8")
Width	63mm (2.4")
Length	54mm (2.1")
Weight	0.11lbs. (90 g)

3.4 Low Voltage Operation

Normal operating voltage for the TY91 is any voltage between 11 and 33 volts, whilst normal operating voltage for the TY92 is any voltage between 22 and 33 volts. At these voltages all functions behave normally, and transmitter power meets the applicable Class requirements of ED-23C.

The radio will continue to operate at a lower voltage than these ranges. As the available voltage falls, the transmitter output power will be reduced, and at 9 volts the nominal transmitter power will be approximately 2.5 watts. The transmitter will be inhibited below 8 volts.

The receiver also works below the nominal voltage. All receiver functions will work normally, but as a safety feature to preserve battery power in an emergency, at 10 volts or below the available speaker volume will reduce significantly.

In addition a warning message will be displayed on the controller when the bus voltage falls below 10 volts in a TY91, or 18 volts in a TY92.

3.5 Installation Approval

The conditions and tests required for the TSO approval of the TY91/TY92 VHF radio are minimum performance standards. It is the responsibility of those desiring to install this VHF radio on or within a specific type or class of aircraft to determine that the aircraft operating conditions are within the TSO standards. The VHF radio may be installed only if further evaluation by the user/installer documents an acceptable installation that is approved by the appropriate airworthiness authority.

4. Unit and Accessories supplied

4.1 TY91 VHF radio Items

The TY91 VHF radio includes the following items:

Unit Description	Qty	Part Number
TY91 VHF radio	1	00882-00-01
TY91/TY92 Mounting Tray	1	00667-00

4.2 TY92 VHF radio Items

The TY92 VHF radio includes the following items:

Unit Description	Qty	Part Number
TY92 VHF radio	1	00879-00-01
TY91/TY92 Mounting Tray	1	00667-00

4.3 TC90 Controller Items

The TC90 controller includes the following items:

Unit Description	Qty	Part Number
TC90 VHF radio Controller	1	00857-00-01
TY91/TY92 Installation Kit	1	00864-00

4.4 Installation Kit

The TY91/TY92 installation kit includes the following items:

Unit Description	Qty	Part Number
TY91/TY92 VHF radio Installation Manual	1	00839-00
TY91/TY92 Pilots Operating Manual	1	00840-00
Mounting adapter (circular hole adapter)	2	00678-00
Connector Co-axial TNC	1	00723-00
Headshell, 15 way	1	00867-00
Headshell, 25 way	1	00726-00
15 way D-type contact housing (female)	1	00865-00
25 way D-type contact housing (female)	1	00866-00
Crimp Terminal, Female, 22-24 AWG	40	00730-00
Long mounting screws, 4-40 thread	4	00736-00
Short mounting screws, 4-40 thread	4	00737-00

4.5 Required Items

Additional items you will require, but which are not in the TY91/TY92 package, include:

- Antenna and fixing hardware. The TY91/TY92 is compatible with any standard 50 ohm vertically polarised antenna with a VSWR better than 2.5:1.
- Cables. You need to supply and fabricate all required cables. Guidance on cable types is given in section 5 below.
- Fixings. To secure the VHF radio tray to the airframe you will need at least 3 flat head screws and three self-locking nuts. If the aircraft does not have existing mounting provisions you may need to fabricate additional brackets to support the VHF radio tray.

5. Installation

5.1 Unpacking and Inspecting Equipment

Carefully unpack the VHF radio and make a visual inspection of the unit for evidence of any damage incurred during shipment. If the unit is damaged, notify the shipping company to file a claim for the damage. To justify your claim, save the original shipping container and all packaging materials.

5.2 Controller Mounting

The TC90 VHF radio controller must be mounted rigidly in the aircraft panel. The controller can be mounted in the ultra compact mounting hole or in a conventional 57mm (2¼ inch) instrument cut-out.

The following installation procedure should be followed, remembering to allow adequate space for installation of cables and connectors.

- Select a position in the panel that is not too close to any high external heat source. (The TC90 is not a significant heat source itself and does not need to be kept away from other devices for this reason).
- Avoid sharp bends and placing the cables too near to the aircraft control cables.

If you are using a 57mm instrument cut-out, you must first clip the two mounting adapters to the controller. The controller should then be mounted using the four LONG screws provided.

Note: The mounting adapters are held in place by the clamping action of the panel installation. As an aid to securing them during assembly when access is poor, we recommend putting a rubber band around the adapters and the control head. The rubber band can be snipped off and discarded when the installation is complete.

If you are using the Trig compact cut-out, you do not need the mounting adapters. The controller should be mounted using the four SHORT screws provided. The screws supplied are appropriate for panel thicknesses from 3

mm to 5 mm. If a thinner panel is used, you may need to exchange the screws for shorter versions since they can bottom out in the mounting holes.

If alternate screws are required, please note that the mounting thread in each case is 4-40.

5.3 VHF Radio Main Unit Mounting

The TY91/TY92 VHF radio is designed to be mounted in any convenient location in the cockpit, the cabin, or an avionics bay.

The following installation procedure should be followed, remembering to allow adequate space for installation of cables and connectors.

- Select a position in the aircraft that is not too close to any high external heat source. (The TY91/TY92 can become warm to the touch itself).
- Avoid sharp bends and placing the cables too near to the aircraft control cables.
- Secure the mounting tray (p/n 00667-00) to the aircraft via the three (3) mounting holes in the tray. The tray should be mounted to a flat surface - it is important that the tray is supported at the dimples as well as the three mounting points.
- Put the TY91/TY92 VHF radio into the secured mounting tray by hooking the connector end under the lip on the tray.
- Lock the TY91/TY92 VHF radio into the mounting tray by clipping the retaining wire over the lugs on the opposite end.

5.4 Cooling Requirements

The TY91/TY92 VHF radio meets all applicable ETSO requirements without forced air-cooling. Reasonable air circulation should be provided.

Attention should be given to the incorporation of cooling provisions to limit the maximum operating temperature if the TY91/TY92 is installed in close proximity to other avionics. The reliability of equipment operating in close

proximity in an avionics bay can be degraded if adequate cooling is not provided.

5.5 TY91/TY92 VHF Radio Electrical Connections

The TY91/TY92 has a single 25 way male socket which provides the audio, data and power inputs to the VHF radio. A single TNC coaxial connector attaches to the antenna.

5.5.1 TY91/TY92 Interface – Pinout

Pin	Signal	Direction
1	Speaker Return	-
2	Speaker Out	Output
3	TMAP1A	Bidirectional
4	TMAP1B	Bidirectional
5	RS232 In	Input
6	RS232 Out	Output
7	TMAP2A	Bidirectional
8	TMAP2B	Bidirectional
9	Ground	-
10	Headphone Return	-
11	Headphone Out	Output
12	Controller Power	Output
13	Power ON	Input
14	PTT2 Key	Input
15	PTT1 Key	Input
16	Reserved	-

17	Intercom Key	Input
18	Transmit Interlock	Input
19	Ground	-
20	Aux Audio	Input
21	Microphone 2	Input
22	Ground	-
23	Microphone 1	Input
24	Aircraft Power (DC)	-
25	Aircraft Power (DC)	-

The following diagram shows the connector orientation as viewed from the wiring side.

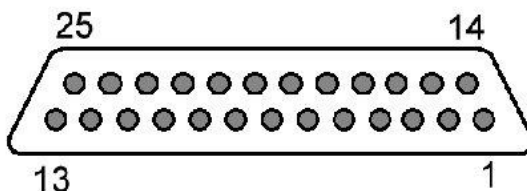

5.6 TY91/TY92 VHF Radio Interface Details

5.6.1 Speaker Output

The speaker output can drive a 4 ohm or 8 ohm cabin speaker. The speaker should be rated at 4 watts or higher.

5.6.2 TMAP Bus

TMAP is a Trig proprietary bus based on RS485 signalling. It provides a bi-directional interface between the VHF radio and the control head. Each TMAP interface comprises a balanced pair of signals, called A and B, both of which

must be connected for communication to work.

There are two sets of TMAP pins on the TY91/TY92, TMAP1 A and B, and TMAP2 A and B.

On the TY91 and TY92 TMAP1 and TMAP2 are wired together internally. The two sets are identical, and either pair (TMAP1 or TMAP2) may be used to connect to the control head.

5.6.3 Headphone Output

The headphone output is intended to drive one or two sets of 300 to 600 ohm headphones which may be connected in parallel, or to drive a conventional 600 ohm audio panel input.

5.6.4 Controller Power

The TC90 controller does not connect to aircraft power – it receives power from the TY91/TY92 using this output. The TY91/TY92 provides 12 volts to the TC90. This output includes short circuit protection, and no fuse is required between the TY91/TY92 and the TC90.

5.6.5 Power On

The TY91/TY92 power supply is controlled by this discrete input. The input is active low, so that the TY91/TY92 will power up whenever the input is held low. This signal is intended to connect to the TC90 Remote ON output.

5.6.6 PTT1/2 Key Input

Two Push to Talk (PTT) inputs are provided, which correspond to the two microphone inputs. Only the corresponding microphone input is routed to the transmitter when the key switch is pressed.

The PTT1 input has priority over the PTT2 input – if the PTT1 switch is closed when the PTT2 switch is closed, the input from Microphone 1 is routed to the transmitter.

The inputs are active low, and will be asserted when the voltage to ground is

pulled below approximately 4 volts. The input should be connected to a momentary switch on the yoke or on the microphone.

5.6.7 Intercom Key Input

The intercom key switch input allows the intercom function to be selected using a remote switch, or permanently enabled by grounding the pin inside the connector. The input is active low, and will be asserted when the voltage to ground is pulled below approximately 4 volts.

If this pin is tied low, the intercom function depends on the vox operated squelch.

Note: It is possible to combine both the key switch and the vox activation, or to use only one. To use only the switch, wire the switch to the intercom key input and select the vox squelch to the lowest setting during configuration. To use only the vox, wire the intercom key input to ground, and configure the squelch accordingly.

5.6.8 Transmit Interlock

When two VHF radios are mounted in an aircraft the transmit interlock of one can be connected to the transmit PTT key of the other radio. When the other radio transmitter is keyed, the squelch threshold of this radio is increased to minimise break-through between one radio and the other.

Note: To improve the performance when using two radios, the antennas should be as far apart as practical – for example on the top and bottom of the fuselage.

5.6.9 Auxiliary Audio Input

This input is continually routed to the headphone and cabin speaker outputs. It is intended for annunciators and identification tones.

Note: The audio bandwidth on the auxiliary input is limited, and is not ideal for MP3 players or other entertainment inputs. If such a device is connected, the mute settings should be enabled in configuration mode so that radio reception and transmission takes

priority over the music input.

5.6.10 Microphone Input

Microphone connections should be made using shielded twisted pair cables.

The two microphone inputs are identical, and have a nominal sensitivity of 100 mV into a 600 ohm load. Phantom power is supplied on the microphone inputs to support a preamplifier.

5.6.11 Power Input

The TY91 power supply can be 11-33 volts DC; no voltage adjustment is required. The TY92 power supply must be 22-33 volts DC. Use a 5 Amp circuit breaker for power supply protection to the TY91 and TY92.

The peak current consumption on transmit exceeds the current capability of a single pin on the connector. Both power inputs must be wired, and at least two ground returns must be wired. This is particularly important when the VHF radio is mounted on a non-conducting surface, such as a composite structure. Use 20 AWG wire for the power connection wires.

5.6.12 Ground Returns

There are only 5 ground pins on the 25 way connector, at pins 1, 9, 10, 19 and 22. A full wiring loom with speaker, two headsets, two microphones, the TC90 connection, power and ground requires 9 ground connections. It is therefore necessary to double up connections to ground pins. This is usually achieved by bringing a short ground wire from a pin that then acts as a bus point inside the D shell.

5.7 TC90 Controller Electrical Connections

The TC90 controller has a single 15 way D type male connector to link to the VHF radio, and optionally to connect to a GPS for loading frequencies of nearby airfields.

5.7.1 TC90 Interface - Pinout

Pin	Signal	Direction
1	Ground	-
2	TMAPA	Bidirectional
3	TMAPB	Bidirectional
4	Ground	-
5	RS232 Tx	Output
6	RS232 Rx	Input
7	Ground	-
8	Remote ON	Output
9	Power IN	Input
10	Power Ground	-
11	Reserved	-
12	Step Button	Input
13	Transfer Button	Input
14	Reserved	-
15	Reserved	-

The following diagram shows the connector orientation as viewed from the wiring side.

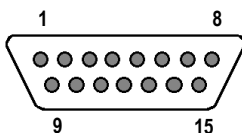

5.8 TC90 Controller Interface Details

5.8.1 TMAP Bus

TMAP is a Trig proprietary bus based on RS485 signalling. It provides a bi-directional interface between the VHF radio and the control head. Each TMAP interface comprises a balanced pair of signals, called A and B, both of which must be connected for communication to work.

TMAP A and B lines on the controller should be connected to the corresponding A and B lines of either TMAP1 or TMAP2 on the TY91/TY92.

5.8.2 RS232 Input

The RS232 input allows certain GPS receivers to preload the standby and active frequencies. The TC90 understands the Apollo SL40 protocol (\$PMRRC) based on NMEA, at a speed of 9600 bps, and responds to message types 1, 4, 5 and 6.

The RS232 output can be used for status monitoring of the radio if required.

5.8.3 Remote ON

This output is connected directly to the Power/Mode switch on the TC90, and should be connected to the Power ON discrete input of the TY91/TY92.

5.8.4 Power

The TC90 uses 12 volts which is available from the TY91/TY92 VHF radio. This input should NOT be connected to aircraft power.

5.8.5 Step Button

The step button is used to allow remote operation of the radio, and is typically used in a helicopter. Each time the step input is grounded, the next memorised frequency is copied to the standby position. The input is active low, and will be asserted when the voltage to ground is pulled below approximately 4 volts.

5.8.6 Transfer Button

The transfer button is used to allow remote activation of the frequency change, and is typically used in a helicopter. The input is active low, and will be asserted when the voltage to ground is pulled below approximately 4 volts.

5.9 D Connector Crimp Terminals

The 25 way and 15 way connectors supplied with the TY91/TY92 installation kit are MIL standard versions of the popular sub miniature D type connector family, and use individual crimp terminals and a receptacle. The MIL specification for this family of connectors is MIL-C-24308. We supply crimp terminals because these are more reliable than soldered connections, and are easier to assemble in-situ in an aircraft, where soldering is impractical. They also allow individual wires to be removed and replaced in a receptacle without replacing the whole connector.

The socket contacts used in the connectors conform to MIL part number M39029/63-368, and are also suitable for wire gauges from 20 to 24 AWG.

These contacts are widely used in avionics installation, and there are many tools available on the market that will reliably crimp them to the wiring. Because the contacts are a MIL standard, there is also a MIL standard for the crimp tool, although other proprietary solutions are also available.

The MIL reference for the basic style of hand tool is M22520/2-01. This style of tool can crimp many different contact types, and relies on interchangeable "positioners" to hold the actual contact in use. The MIL reference for the positioner that you need for the crimps we supply is M22520/2-08.

Any tool that complies with these references can be used to crimp these contacts. One of the most popular vendors of these small hand tools is Daniels Manufacturing Corporation (see www.dmctools.com). Their AFM8 hand tool complies with M22520/2-01, and their K13-1 positioner is M22520/2-08 compliant, so the combination will crimp the supplied connectors.

Once crimped, the contacts should be slotted into the rear of the connector shell. Push the contact in until the retaining tab clicks into place. Tug gently to confirm the contact is locked in place.

5.10 Wiring Considerations

5.10.1 TC90 Interconnect

The connection from the TY91/TY92 VHF radio to the TC90 uses a minimum of six (6) signal lines; the TMAP pair, the Power and Ground pair, and the Remote On discrete line plus associated ground line. In a certified installation the normal wire choice would be Tefzel hook-up wire. Wire of 20 AWG is more than adequate for the task; in installations where weight is an issue, wire of 22 or 24 AWG can also be used. Where lighter wires than 20 AWG are used the individual wires should be laced together for support.

The TY91/TY92/TC90 interface was tested and certified using unshielded, untwisted wiring, and that is sufficient for a certified installation. There may however be technical benefits of improved electromagnetic emissions and susceptibility to and from the VHF radio system if the two wires of the TMAP pair are lightly twisted together – one twist per 1 to 2 inches is appropriate. This may reduce interference and break-through on adjacent audio wiring if it is not possible to route them separately. For tidiness and consistency the other pairs in the bundle can also be twisted, but there will be no particular difference in behaviour.

The distance between the TY91/TY92 VHF radio and the TC90 controller is limited by the impedance of the wire between them. The TC90 is powered from the TY91/TY92, not from aircraft power, and therefore the acceptable voltage drop in the power line is what limits the distance.

The TC90 needs an impedance of less than 1 ohm in the power line for satisfactory operation. The following table gives guidelines for typical aircraft hook-up wire. Note that different brands may vary – check your supplier for details.

Gauge	Ohm/km	Length for 1 Ohm
20 AWG	35	28.4 m
22 AWG	64	15.6 m
24 AWG	99	10.0 m

An alternative to a harness built from individual wires, particularly for a long cable run, is to use a multi-core cable. Aviation grade cable with 6 or more cores is often more expensive than the individual wires, and therefore is not generally a good choice for a certified aircraft. For aircraft where those considerations do not apply however, an attractive alternative solution may be to use 3 pair or 4 pair data cable.

Whilst appropriate cables may exist, please note that not all data cable is suitable for this application. Cables with solid cores should not be used, and cables should be selected based on the wear characteristics of their insulation material, including temperature rating, resistance to solvents and oils, and flammability. Most inexpensive commercial data cables have poor flammability properties.

Note: If you are installing more than one Trig TY91/TY92 radio, or installing a radio with a Trig TT21/TT22 transponder, then bundling the TC90 and TC20 control head interconnecting wires into one loom is acceptable and will not cause any interference between the two units. The same is not true of the audio wiring or antenna wiring – these should be kept apart using normal wiring practices.

5.10.2 Audio wiring

For any wires carrying an audio signal, a screened twisted pair should be used to avoid any unwanted signals interfering with the radio installation. Unscreened wires can act as small antennas and transmissions from other avionics on the aircraft could be picked up by the radio and heard as interference in the connected headsets. For example, Mode S transponder transmissions can be audible as clicking sounds in the headset and cause an annoying distraction to the pilot.

Correctly terminated screened wiring will limit any unwanted transmissions being picked up by the radio and should be used on the MIC and PHONE lines.

5.11 Antenna Installation

The antenna should be installed according to the manufacturer's instructions.

The following considerations should be taken into account when siting the Antenna.

- The antenna should be well removed from any projections, the engine(s) and propeller(s). It should also be well removed from landing gear doors, access doors or others openings which will break the ground plane for the antenna.
- The antenna should be mounted in a vertical position when the aircraft is in level flight.
- Avoid mounting the antenna within 2 feet of a GPS antenna, and as far as practical from any ELT antenna.
- If the simultaneous use of two radio units is required then each antenna should be as far apart as practicable for maximum isolation. We would recommend placing one antenna on top and one on the bottom of the airframe. The Transmit Interlock function must also be used in this case (section 5.6.8).
- Where practical, plan the antenna location to keep the cable lengths as short as possible and avoid sharp bends in the cable to minimise the VSWR.

Electrical connection to the antenna should be protected to avoid loss of efficiency as a result of the presence of liquids or moisture. All antenna feeders shall be installed in such a way that a minimum of RF energy is radiated inside the aircraft.

5.11.1 Antenna Ground Plane

When a conventional aircraft monopole antenna is used it relies on a ground plane for correct behaviour. For ideal performance the ground plane should be as large as practical; in any case at least 1 metre square. In a metal skinned aircraft this is usually easy to accomplish, but is more difficult in a composite or fabric skinned aircraft. In these cases a metallic ground plane should be fabricated and fitted under the antenna.

The thickness of the material used to construct the ground plane is not critical, providing it is sufficiently conductive. A variety of proprietary mesh and grid

solutions are available. Heavyweight cooking foil meets the technical requirements, but obviously needs to be properly supported.

5.11.2 Antenna Cable

Use a high quality 50 ohm coaxial cable, such as RG400 or RG142B.

When routing the cable, ensure that you:

- Route the cable away from sources of heat.
- Route the cable away from potential interference sources such as ignition wiring, 400Hz generators, fluorescent lighting and electric motors.
- Allow a minimum separation of 300mm (12 inches) from an ADF antenna cable.
- Keep the cable run as short as possible.
- Avoid routing the cable round tight bends.
- Avoid kinking the cable even temporarily during installation.
- Secure the cable so that it cannot interfere with other systems.

5.11.3 TNC Connector

This section describes the technique for attaching the antenna cable to the supplied TNC connector.

The supplied connector can be completed using a wide range of commercial crimp tools (for example the Tyco 5-1814800-3). The die apertures for the inner pin and the outer shield should be approximately 1.72 mm and 5.41 mm respectively.

- Strip back the coax cable to the dimensions in the table, as shown in the diagram below. Slide 25 mm (1 inch) of heat shrink tubing over the cable.
- Slide the outer crimp sleeve over the cable – it must go on before securing the centre contact.

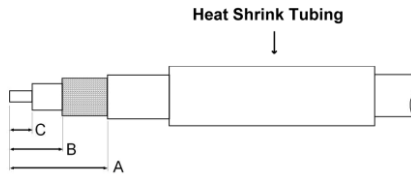

Dimension	Cut size (mm)	Cut size (inches)
A	17.5	0.69
B	7.2	0.28
C	4.8	0.19

- Crimp the centre contact to the cable.
- Insert the cable into the connector – the centre contact should click into place in the body, the inner shield should be inside the body of the connector and the outer shield should be outside the body.
- Crimp the outer sleeve over the shield.
- Slide heat shrink tubing forward (flush to connector) and heat to shrink the tubing.

6. Installation Setup and Test

6.1 Initial Power On

The TC90 will display a splash screen when the radio is first switched on. The splash screen show the software versions currently loaded and what model of radio is connected.

6.2 Configuration Items

There are a small number of installation parameters that can be adjusted. These parameters are accessed by turning on the radio and then pressing and holding the MON button for approximately 2 seconds. The individual setup items can then be selected using the large tuning knob, and adjusted using the small tuning knob. Pressing MON again will exit from the setup mode.

The script will prompt for the following configuration items:

- Intercom Volume
- Intercom Squelch
- Auxiliary Input Volume
- Auxiliary Input Muting
- Sidetone Volume
- Receiver Squelch Offset
- Frequency Step Size

6.2.1 Intercom Volume

This setting controls the volume of the intercom.

6.2.2 Intercom Squelch

The intercom includes a voice activated squelch control to limit the background noise heard over the intercom. Increasing the squelch level requires a louder microphone input to gate the intercom.

6.2.3 Auxiliary Input Volume

The auxiliary input is a low-fidelity monophonic input intended for nav radio ident inputs and simple annunciators. This setting controls the relative volume of the auxiliary audio input.

6.2.4 Auxiliary Input Muting

This allows the auxiliary input to be muted when the radio is receiving or transmitting speech. Turn this feature ON if the auxiliary input is being used for non-essential services, like an MP3 player. Turn this feature OFF if the auxiliary input is being used for essential services like annunciators or traffic alerts.

6.2.5 Sidetone Volume

The audio sidetone is the transmitted audio signal; this setting controls the level of the sidetone in the headphones.

6.2.6 Receiver Squelch Offset

The receiver has a factory set nominal squelch point of approximately -95 dBm which should be appropriate for most installations. In some aircraft with noisy electrical environments, such as vintage or experimental aircraft, the factory setting may lead to nuisance squelch changes triggered by noise.

The receiver squelch offset allows the installer to moderately increase the squelch set point.

6.2.7 Frequency Step Size

The TY91/TY92 is capable of operating in both an 8.33 kHz and 25 kHz environment. If 8.33 kHz operation is not required, the 8.33 kHz channels can be disabled to simplify the tuning operation.

Note: 8.33 kHz operation is required in some European airspace.

7. Post Installation Checks

Post installation checks should be carried out in accordance with your certification requirements. These checks should include:

- Receiver operation. Tune a local station and check that the reception is clear and understandable.
- Transmitter operation. Contact a local station and check that they are receiving you successfully.
- Interference check. Check the radio with other avionics and electrical equipment on the aircraft operating. Check at low, mid and high radio frequencies. There should be no significant interference on reception, and when the TY91/TY92 transmits there should be no adverse effect on any other equipment.
- Sidetone adjustment. During the transmit checks, verify the sidetone level is set appropriately.
- Intercom adjustment. If the intercom function is being used, set the listening level and squelch appropriately. Note that setting the squelch is only normally possible with the engine(s) running and developing power.

8. Normal Operation

8.1 Overview

On the front panel is a monochrome LCD display flanked by a rotary volume knob (OFF, and Squelch function) and a dual concentric tuning knob used for frequency entry.

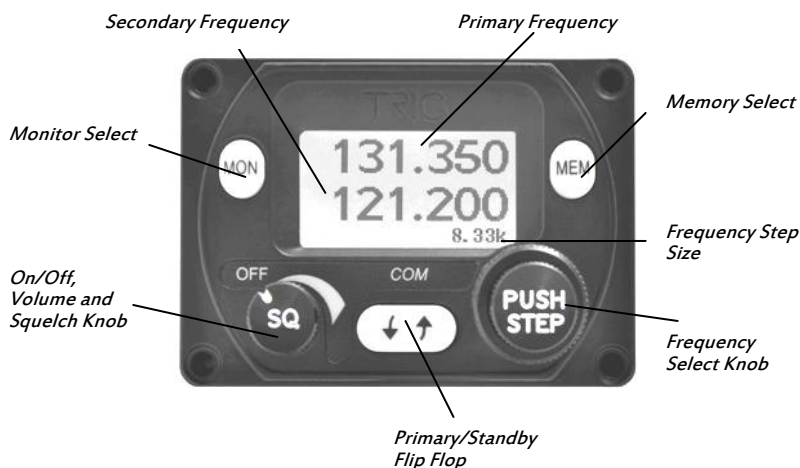

8.2 Display

The display shows the active and standby frequencies for the radio, and has annunciators for operating modes.

8.3 On/Off Volume Knob

The left hand knob controls the power to the VHF radio and the audio volume. Pressing the left hand knob toggles the radio squelch on and off, which can be used to listen for faint stations, and as a simple audio test.

8.4 Tuning Knobs

The right hand knobs are used to tune the radio. The large knob adjusts the MHz portion of the standby frequency, and the smaller knob adjusts the kHz portion of the standby frequency.

Pressing the end of the small knob changes the channel spacing that the small knob operates through. If the radio is configured for 8.33 kHz operation, the steps toggle between 8.33 kHz channels and 25 kHz channels. If the radio is configured only for 25 kHz operation, the steps toggle between 25 kHz and 50 kHz channels. Changing the step size does not change the behaviour of the radio, only the tuning knob step size – it helps to quickly tune a frequency.

8.5 Flip-flop Button

The Flip-flop button swaps the frequency in the standby display, at the bottom of the screen, into the active position, and moves the active frequency to the standby position.

8.6 MON Button

The TY91/TY92 includes a dual-frequency listen feature; pressing the MON button toggles this feature on and off.

When the feature is active, a +2 icon appears next to the standby frequency, and the radio will scan between the active and standby frequencies listening for transmissions.

This is useful in an aircraft with only a single radio, since it allows you, for example, to copy the ATIS whilst maintaining a listening watch on the ATC frequency.

8.7 MEM Button

Behaviour of the MEM button depends on whether you have a GPS connected that can load frequencies into the TC90. If you do, then pressing the MEM button allows access to those frequencies. Turning the LARGE knob steps through the airports for which frequencies have been loaded. Turning the

SMALL knob then steps through the individual frequencies for that airport.

After you have stepped through all the loaded airports, or if there is no GPS attached, the built-in memory of the TC90 is displayed.

The TC90 has nine frequency memories. Each frequency position can be selected by turning the SMALL tuning knob.

Whether from a GPS or from the onboard memory bank, the selected frequency is loaded into the standby window. Pressing MEM again leaves the stored frequency in the standby window. Pressing the Flip-flop button loads the stored frequency directly into the active channel.

To store a frequency in one of the memory locations it must first be tuned and active. Press MEM to enter the memory mode in the usual way. Select the channel you want to overwrite with the tuning knobs. Now press, AND HOLD, the MEM button for 2 seconds. The current active frequency will be moved to the selected memory location, overwriting the existing contents.

8.8 General Low Temperature Operation

The TY91/TY92 is certified to operate correctly down to -20°C , but at low temperatures the controller display may be impaired. On a cold day you may need to wait for the cockpit to warm up to ensure normal operation.

8.9 Warning Messages

If the VHF radio detects a problem, the screen will indicate WARNING and a brief statement of the problem. Depending on the nature of the problem, your VHF radio may not be working properly. Note the message on the screen and pass that information to your avionics maintenance organisation. Press ENT to clear the message; if the fault is still present the message will reappear.

8.10 Fault Annunciation

If the VHF radio detects a catastrophic internal failure, the screen will indicate FAULT and a brief statement of the problem. No replies will be made to interrogations when a fault has been detected.

Some FAULT indications can be recovered by switching the VHF radio off and back on again, although in all cases a FAULT code implies that there is a fault with the VHF radio or the installation. Note the FAULT message shown on the screen and pass that information to your avionics maintenance organisation.

9. Continued Airworthiness

Other than for periodic functional checks required by the regulations, the TY91/TY92 VHF radio has been designed and manufactured to allow “on condition maintenance”. This means that there are no periodic service requirements necessary to maintain continued airworthiness, and no maintenance is required until the equipment does not properly perform its intended function. When service is required, a complete performance test should be accomplished following any repair action. Repairs should only be carried out in accordance with Trig Avionics Limited service procedures.

10. Limited Warranty

Trig Avionics Limited warrants our products to be free from defects in materials and workmanship for a period of two (2) years from the date of installation by an authorised dealer.

This warranty covers repair and/or replacement at our option, of any parts found to be defective, provided such defects in our opinion are due to faulty material or workmanship and are not caused by tampering, abuse, or normal wear.

All warranties are F.O.B.

Trig Avionics Limited
Heriot Watt Research Park
Riccarton, Currie, EH14 4AP

Trig Avionics will not accept or pay for any charges for warranty work performed outside our factory without prior written consent.

This warranty applies only to products in normal use. It does not apply to units or circuit boards defective due to improper installation, physical damage, tampering, lightning or other electrical discharge, units with altered serial numbers, or units repaired by unauthorised persons or in violation of Trig Avionics Limited service procedures.

Trig Avionics Limited assumes no responsibility for any consequential losses of any nature with respect to any products or services sold, rendered, or delivered.

11. Environmental Qualification Forms

Nomenclature:	TY91 VHF radio	
Part No: 00882-00-01	ETSO: 2C169a	
Manufacturer:	Trig Avionics Limited	
Address:	Heriot Watt Research Park, Riccarton, Currie, Scotland, EH14 4AP	
Conditions	DO-160F Section	Description of Conducted Tests
Temperature and Altitude	4.0	Equipment tested to Categories A2, C1
Low temperature ground survival	4.5.1	-55°C
Low temperature short-time operating	4.5.1	-40°C
Low temperature operating	4.5.2	-20°C
High temperature operating	4.5.4	+70°C
High temperature short-time operating	4.5.3	+70°C
High temperature ground survival	4.5.3	+85°C
Loss of Cooling	4.5.5	Cooling air not required (+70°C operating without cooling air)
Altitude	4.6.1	55,000 feet
Decompression	4.6.2	8,000 to 35,000 feet in 15 seconds
Overpressure	4.6.3	-15,000 feet
Temperature Variation	5.0	Equipment tested to Category B
Humidity	6.0	Equipment tested to Category A
Operational Shocks	7.2	Equipment tested to Category B
Crash Safety	7.3	Equipment tested to Category B type 5

Vibration	8.0	Aircraft zone 2; type 3, 4, 5 to category S level M, type 1 (Helicopters) to category U level G
Explosion	9.0	Equipment identified as Category X – no test required
Waterproofness	10.0	Equipment identified as Category X – no test required
Fluids Susceptibility	11.0	Equipment identified as Category X – no test required
Sand and Dust	12.0	Equipment identified as Category X – no test required
Fungus	13.0	Equipment identified as Category X – no test required
Salt Spray	14.0	Equipment identified as Category X – no test required
Magnetic Effect	15.0	Equipment tested to Category Z, safe distance 1 metre
Power Input	16.0	Equipment tested to Category BX
Voltage Spike	17.0	Equipment tested to Category B
Audio frequency conducted susceptibility	18.0	Equipment tested to Category B
Induced signal susceptibility	19.0	Equipment tested to Category AC
Radio frequency susceptibility	20.0	Equipment tested to Category TT
Radio frequency emission	21.0	Equipment tested to Category B
Lightning induced transient susceptibility	22.0	Equipment tested to Category B2H22
Lightning direct effects	23.0	Equipment identified as Category X – no test required
Icing	24.0	Equipment identified as Category X – no test required
Electrostatic Discharge	25.0	Equipment identified as Category X – no test required
Fire, Flammability	26.0	Equipment identified as Category C

Nomenclature:	TY92 VHF radio	
Part No: 00879-00-01	ETSO: 2C169a	
Manufacturer:	Trig Avionics Limited	
Address:	Heriot Watt Research Park, Riccarton, Currie, Scotland, EH14 4AP	
Conditions	DO-160F Section	Description of Conducted Tests
Temperature and Altitude	4.0	Equipment tested to Categories A2, C1
Low temperature ground survival	4.5.1	-55°C
Low temperature short-time operating	4.5.1	-40°C
Low temperature operating	4.5.2	-20°C
High temperature operating	4.5.4	+55°C
High temperature short-time operating	4.5.3	+70°C
High temperature ground survival	4.5.3	+85°C
Loss of Cooling	4.5.5	Cooling air not required (+55°C operating without cooling air)
Altitude	4.6.1	55,000 feet
Decompression	4.6.2	8,000 to 35,000 feet in 15 seconds
Overpressure	4.6.3	-15,000 feet
Temperature Variation	5.0	Equipment tested to Category C
Humidity	6.0	Equipment tested to Category A
Operational Shocks	7.2	Equipment tested to Category B
Crash Safety	7.3	Equipment tested to Category B type 5
Vibration	8.0	Aircraft zone 2; type 3, 4, 5 to category S level M, type 1 (Helicopters) to category U level G

Explosion	9.0	Equipment identified as Category X – no test required
Waterproofness	10.0	Equipment identified as Category X – no test required
Fluids Susceptibility	11.0	Equipment identified as Category X – no test required
Sand and Dust	12.0	Equipment identified as Category X – no test required
Fungus	13.0	Equipment identified as Category X – no test required
Salt Spray	14.0	Equipment identified as Category X – no test required
Magnetic Effect	15.0	Equipment tested to Category Z
Power Input	16.0	Equipment tested to Category BX
Voltage Spike	17.0	Equipment tested to Category B
Audio frequency conducted susceptibility	18.0	Equipment tested to Category B
Induced signal susceptibility	19.0	Equipment tested to Category AC
Radio frequency susceptibility	20.0	Equipment tested to Category TT
Radio frequency emission	21.0	Equipment tested to Category B
Lightning induced transient susceptibility	22.0	Equipment tested to Category B2H22
Lightning direct effects	23.0	Equipment identified as Category X – no test required
Icing	24.0	Equipment identified as Category X – no test required
Electrostatic Discharge	25.0	Equipment identified as Category X – no test required
Fire, Flammability	26.0	Equipment identified as Category C

Nomenclature	TC90 Radio Controller	
Part No: 00857-00-01	ETSO: 2C169a	
Manufacturer	Trig Avionics Limited	
Address	Heriot Watt Research Park, Riccarton, Currie, Scotland, EH14 4AP	
Conditions	DO-160F Section	Description of Conducted Tests
Temperature and Altitude	4.0	Equipment tested to Categories A4, C4
Low temperature ground survival	4.5.1	-55°C
Low temperature short-time operating	4.5.1	-25°C
Low temperature operating	4.5.2	-20°C
High temperature operating	4.5.3	+55°C
High temperature short-time operating	4.5.3	+70°C
High temperature ground survival	4.5.3	+85°C
Loss of Cooling	4.5.5	Cooling air not required (+70°C operating without cooling air)
Altitude	4.6.1	35,000 feet
Decompression	4.6.2	8,000 to 35,000 feet in 15 seconds
Overpressure	4.6.3	-15,000 feet
Temperature Variation	5.0	Equipment tested to Category A
Humidity	6.0	Equipment tested to Category A
Operational Shocks	7.2	Equipment tested to Category B
Crash Safety	7.3	Equipment tested to Category B type 5
Vibration	8.0	Aircraft zone 2; type 3, 4, 5 to category S level M, type 1 (Helicopters) to category U level G

Explosion	9.0	Equipment identified as Category X – no test required
Waterproofness	10.0	Equipment tested to Category W (front face only)
Fluids Susceptibility	11.0	Equipment identified as Category X – no test required
Sand and Dust	12.0	Equipment identified as Category X – no test required
Fungus	13.0	Equipment identified as Category X – no test required
Salt Spray	14.0	Equipment identified as Category X – no test required
Magnetic Effect	15.0	Equipment tested to Category Z
Power Input	16.0	Equipment identified as Category X – no test required
Voltage Spike	17.0	Equipment identified as Category X – no test required
Audio frequency conducted susceptibility	18.0	Equipment identified as Category X – no test required
Induced signal susceptibility	19.0	Equipment tested to Category BC
Radio frequency susceptibility	20.0	Equipment tested to Category TT
Radio frequency emission	21.0	Equipment tested to Category M
Lightning induced transient susceptibility	22.0	Equipment tested to Category B2H22
Lightning direct effects	23.0	Equipment identified as Category X – no test required
Icing	24.0	Equipment identified as Category X – no test required
Electrostatic Discharge	25.0	Equipment tested to Category ?
Fire, Flammability	26.0	Equipment identified as Category C

12. Installation Drawings

12.1 Mounting tray fixing and overall dimensions

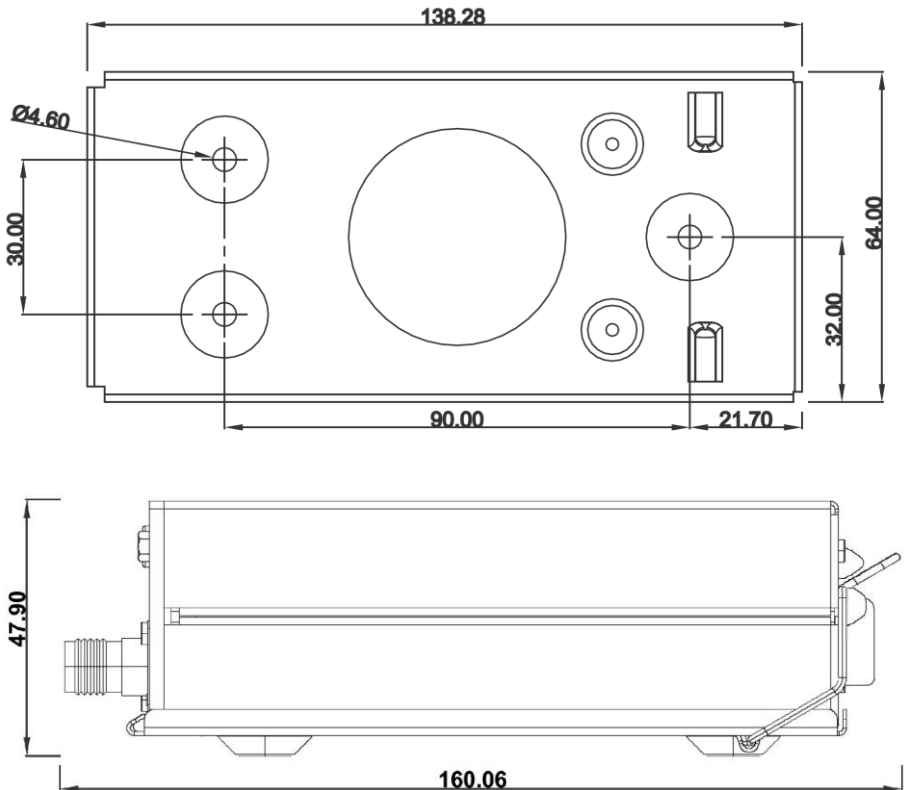

All dimensions in millimetres

12.2 Front Panel Controller Dimensions

Controller shown without the mounting adapters (00678-00) used for 57mm (2¼ inch) instrument mounting.

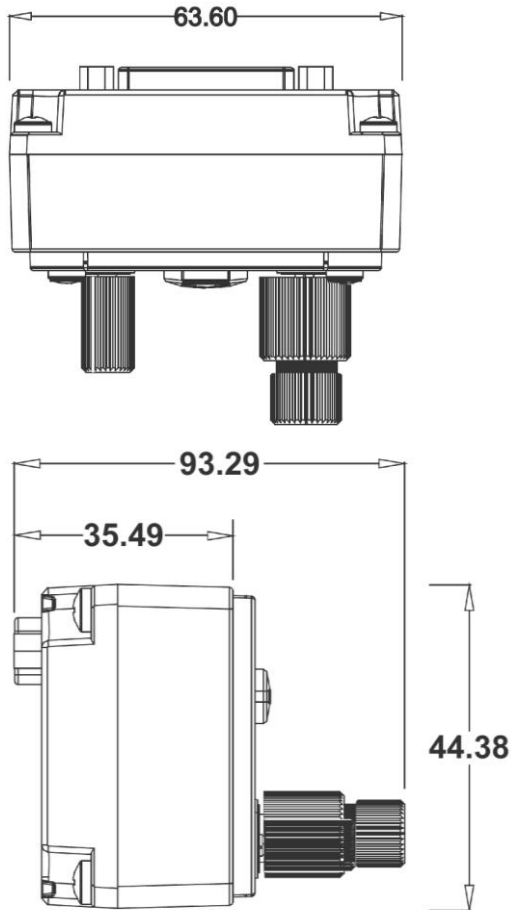

All dimensions in millimetres.

12.3 Front Panel Cut-out Options

The front panel controller can be fitted to either the compact mounting hole or a conventional 57mm (2¼ inch) instrument cut-out. The compact mounting is a truncated 58 mm opening; please note that the mounting screws are NOT in the same location for the two options.

Note: The following diagram is intended to be to scale, however variations in the printing process mean that you MUST check all dimensions before using it as a template.

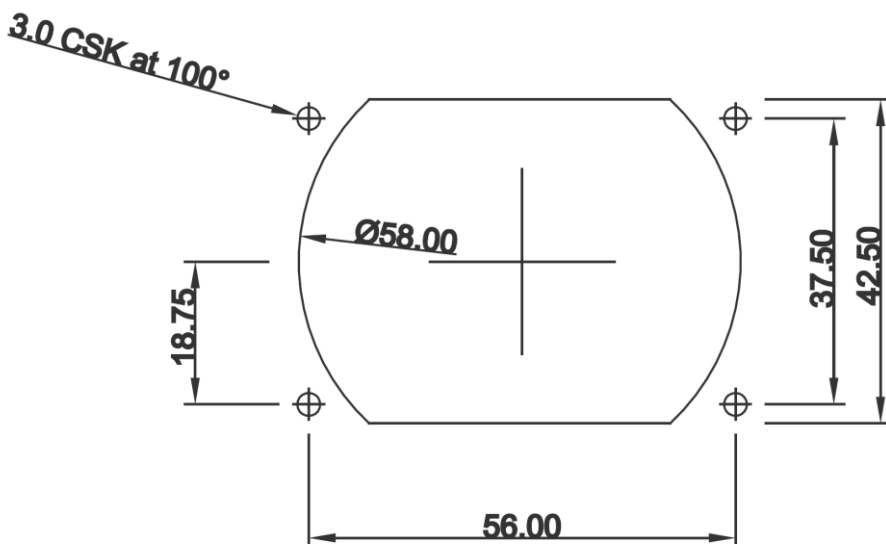

Note: The following diagram is intended to be to scale, however variations in the printing process mean that you MUST check all dimensions before using it as a template.

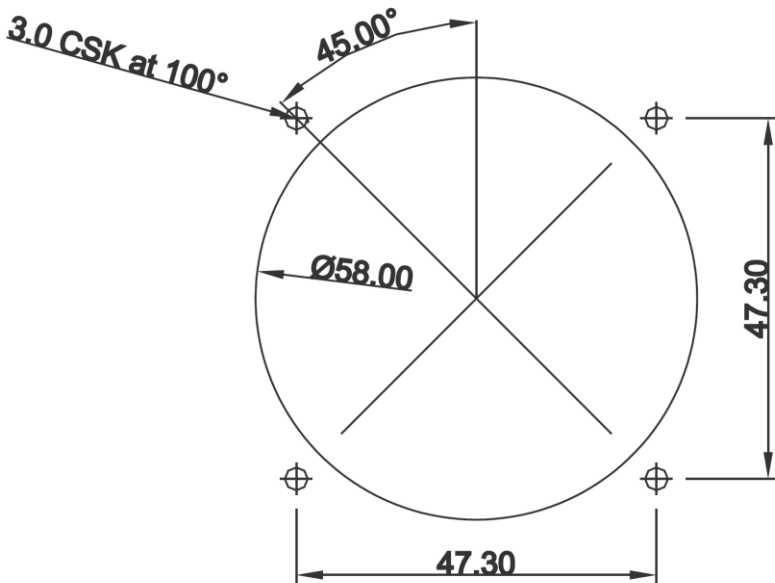

All dimensions in millimetres.

13. Wiring Diagrams

Diagram 1: TY91/TY92 Typical Interconnect	52
Diagram 2: Audio Panel Connections	52
Diagram 3: GPS Connection	52

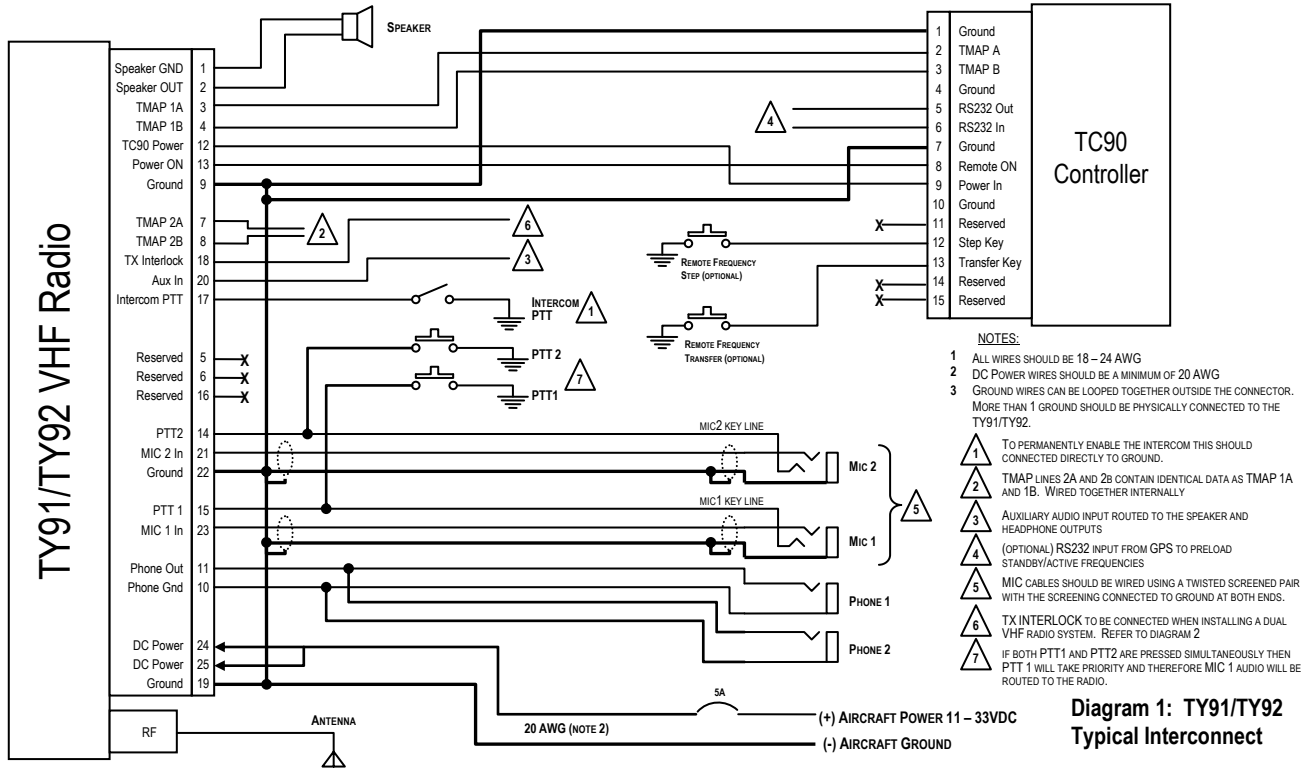

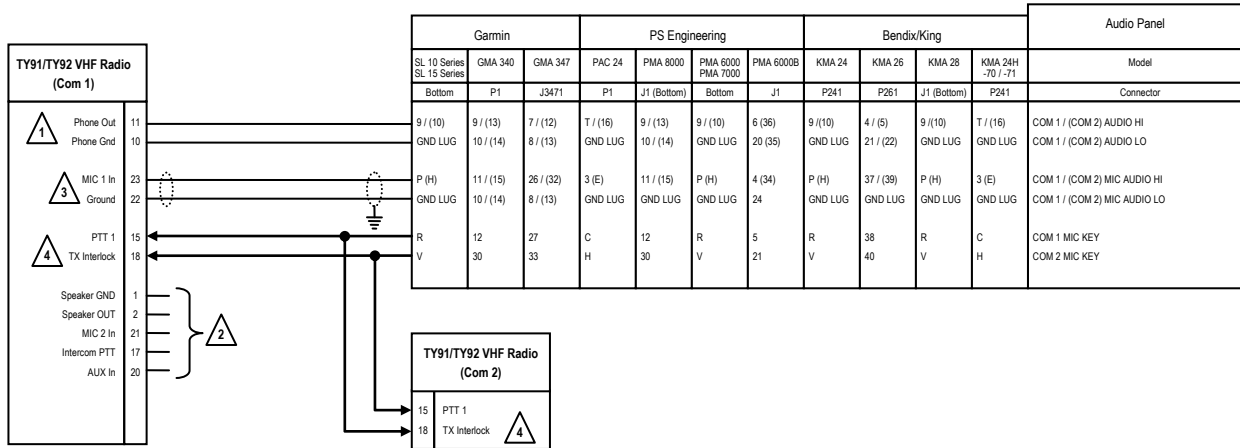

NOTES:

1 ALL WIRES SHOULD BE 18-24 AWG

1 THE 500 OHM AUDIO OUTPUTS ARE BALANCED AND THE PHONE GND MUST BE CONNECTED. IF THE AUDIO PANEL DOES NOT HAVE AN AUDIO LO IT SHOULD BE CONNECTED TO A GROUND LUG AT THE AUDIO PANEL.

2 THESE INPUTS/OUTPUTS ARE DESIGNED FOR A STANDALONE SYSTEM AND SHOULD NOT BE CONNECTED WHEN INTEGRATING THE RADIO WITH AN AUDIO PANEL. MOST AUDIO PANELS WILL HAVE DEDICATED CONNECTIONS FOR THESE FEATURES WHICH SHOULD BE USED INSTEAD.

3 SCREENED CABLE TO MIL 22750 OR 27500 AND THE SCREEN SHOULD ONLY BE EARTHED AT THE AUDIO PANEL END.

4 FOR A DUAL RADIO INSTALLATION CONNECT THE TRANSMIT INTERLOCK TO THE MIC KEY / PTT OF THE OTHER VHF TRANSCIVER TO MINIMIZE SQUELCH BREAKS ON THE COM.

Diagram 2: Audio Panel Connections

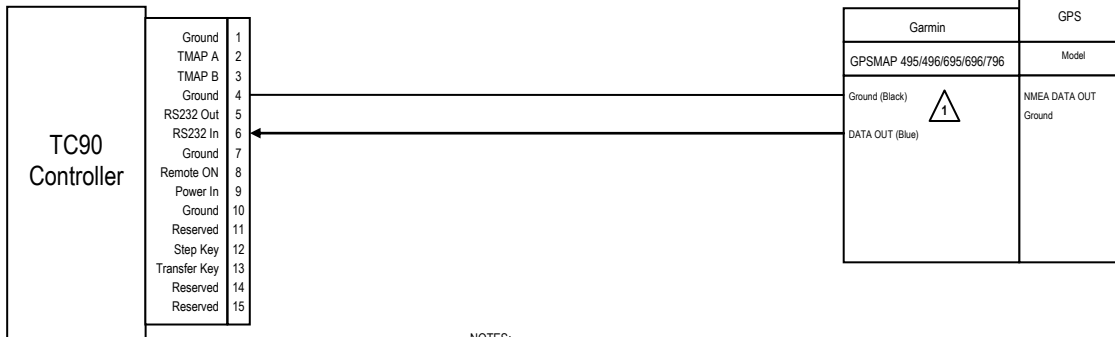

NOTES:

1 ALL WIRES SHOULD BE 18 – 24 AWG



OUTPUT FORMAT SHOULD BE SET TO "TIS IN / NMEA & VHF OUT" or "AVIATION IN / NMEA & VHF OUT".

**Diagram 3: GPS
Connection**

This page intentionally left blank