

# SecureMesh™ Gateway



## Contents

<b>INTRODUCTION .....</b>	<b>3</b>
SECUREMESH GATEWAY COMPONENTS .....	3
ACCESSORIES .....	5
<b>PREPARING FOR INSTALLATION .....</b>	<b>6</b>
REQUIRED EQUIPMENT .....	6
OPTIONAL EQUIPMENT .....	6
INSTALLATION LOCATION .....	7
PRE-PROVISIONING .....	8
<b>INSTALLING THE GATEWAY .....</b>	<b>8</b>
UTILITY POLE OR TOWER INSTALLATION .....	9
<i>Mounting the Device .....</i>	<i>9</i>
<i>Grounding and Protecting the Device .....</i>	<i>10</i>
<i>Connecting the Device to a Source of Power .....</i>	<i>11</i>
<i>Completing the installation .....</i>	<i>12</i>
STREETLIGHT POLE MOUNTING AND GROUNDING .....	13
<i>Mounting the Device .....</i>	<i>13</i>
<i>Connecting the Device to a Source of Power .....</i>	<i>15</i>
<i>Completing the Installation .....</i>	<i>16</i>
<b>COMMISSIONING THE GATEWAY .....</b>	<b>17</b>
CONFIGURING THE SECUREMESH GATEWAY .....	17
MONITORING THE POWER-ON SEQUENCE .....	17
<b>APPENDIX A .....</b>	<b>18</b>
GROUNDING GUIDELINES .....	18
<b>APPENDIX B .....</b>	<b>20</b>
REGULATORY INFORMATION .....	20

## SAFETY INFORMATION

**Hazard Warning!**

High Voltage. This situation or condition can cause injury due to electric shock.

**Warnung!**

Lesen und befolgen Sie die Warnhinweise und Anweisungen, die auf dem Produkt angebracht oder in der Dokumentation enthalten sind.

**Warning!**

Read and follow all warning notices and instructions marked on the product or included in the documentation.

**Warnung!**

Lesen und befolgen Sie die Warnhinweise und Anweisungen, die auf dem Produkt angebracht oder in der Dokumentation enthalten sind.

**Warning!**

Only use attachments and accessories specified and/or sold by the manufacturer.

**Warnung!**

Verwenden Sie nur Zusatzgeräte und Zubehör angegeben und / oder verkauft wurde durch den Hersteller.

**Warning!**

Refer all servicing to qualified service personnel. Servicing is required when the device has been damaged in any way, such as power-supply cord or plug is damaged, liquid has been spilled or objects have fallen into the device, the device has been exposed to rain or moisture, does not operate normally, or has been dropped.

**Warnung!**

Das Gerät sollte nur von qualifizierten Fachkräften gewartet werden. Eine Wartung ist fällig, wenn das Gerät in irgendeiner Weise beschädigt wurde, wie bei beschädigtem Netzkabel oder Netzstecker, falls Flüssigkeiten oder Objekte in das Gerät gelangen, das Gerät Regen oder Feuchtigkeit ausgesetzt wurde, nicht ordnungsgemäß funktioniert oder fallen gelassen wurde.

**Warning!**

Do not open the chassis. There are no user-serviceable parts inside. Opening the chassis will void the warranty unless performed by an Trilliant service center or licensed facility.

**Warnung!**

Öffnen Sie das Gehäuse nicht. Keine der Geräteteile können vom Benutzer gewartet werden. Durch das Öffnen des Gehäuses wird die Garantie hinfällig, es sei denn, solche Wartungsarbeiten werden in einem Trilliant-Service-Center oder einem lizenzierten Betrieb vorgenommen.

## INTRODUCTION

The **SecureMesh™ Gateway** performs the function of being the network takeout point and root node. As the root node of the SecureMesh Wide Area Network (WAN), it coordinates all of the nodes in its wireless mesh network, providing a low-latency, high-bandwidth, self-forming, self-balancing, and self-healing wireless network.

The Gateway's 5 GHz SecureMesh WAN radio uses its array of eight, beam-switched, directional antennas to provide extended range and full 360° coverage and acts as the interface of the SecureMesh WAN network to the wired or fiber-optic network.

The Gateway uses an Ethernet port to provide simultaneous power and connection to wired devices such as switches, routers, or VPN routers. If deployed using a SecureMesh Power Service Unit (PSU), the Ethernet port for network connection is made available through the PSU's port.

## SecureMesh Gateway Components

The following diagram shows the major components of the SecureMesh Gateway.

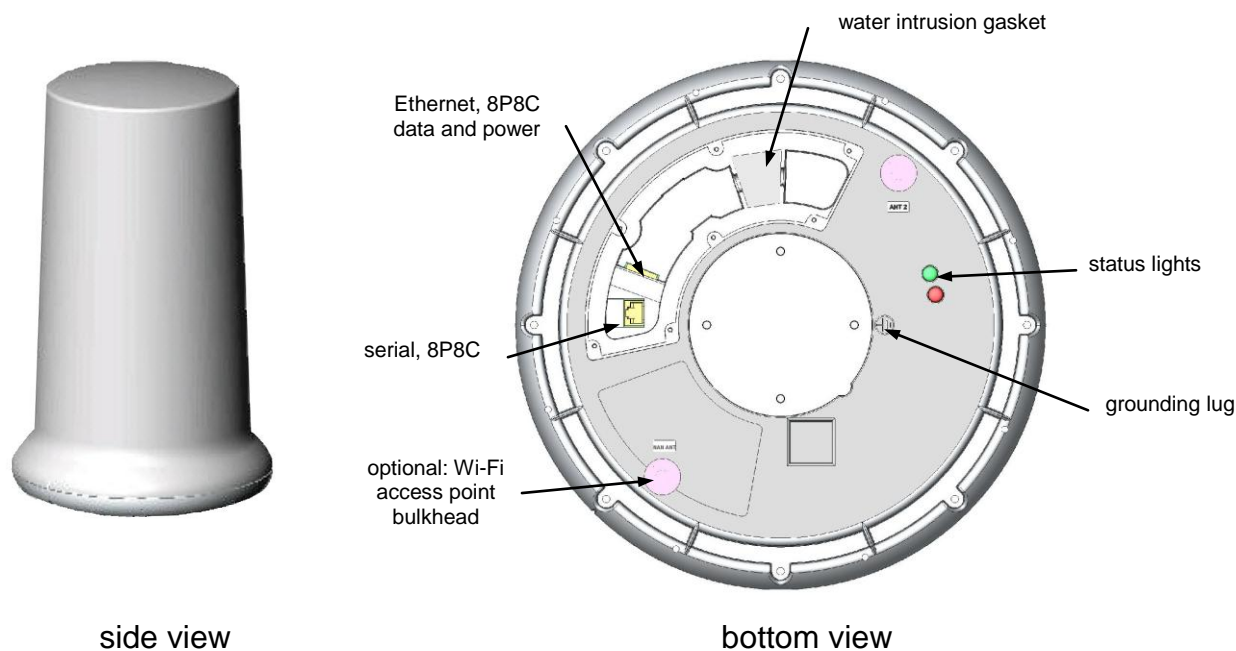

The following diagram shows the SecureMesh Gateway package contents.

SecureMesh Gateway



cover (Ethernet only)



cover (serial cable)



accessory kit



clamp & clamp mount



DB-9 adapter

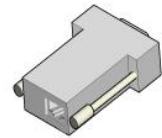

## Accessories

	product number	description
<b>Surge Suppressor</b>	620-00705-01	<b>required</b> unless provided by customer
<b>Horizontal Pole Mounting Bracket</b>	620-R0007-01	for horizontal pole mounting only (e.g., streetlight cantilevers)
<b>Vertical Pole Mounting Bracket</b>	DK-0029A	for vertical pole mounting only (e.g., utility poles)

One of the following power supplies is **required**:

<b>24V Power Service Unit</b>	PSU-1024-33	<ul style="list-style-type: none"> <li>recommended outdoor power supply and backup battery</li> <li>24V PoE connection to SecureMesh Gateway</li> <li>Standard 802.3at 48V PoE connection to client device (without battery backup)</li> <li>33 Amp-hour backup battery (&gt;8 hours backup at 68°F / 20°C)</li> <li>not needed if site location provides an Uninterruptible Power Supply</li> </ul>
<b>Indoor Power Supply w/ PoE Injector</b>	170-R0006-01	<ul style="list-style-type: none"> <li>optional indoor power supply</li> <li>100-240 VAC, 24 VDC, 1.3A</li> <li>power cord sold separately (<i>see below</i>)</li> </ul>
<b>Streetlight Power Supply</b>		<ul style="list-style-type: none"> <li>optional outdoor power supply</li> <li>no battery backup capability</li> </ul>
	620-R0005-01	20-foot / 6-meter cable to photoelectric tap
	620-R0005-02	3-foot / 1-meter cable to photoelectric tap
<b>Streetlight Installation Kit – including Power Supply</b>		<ul style="list-style-type: none"> <li>optional horizontal pole installation kit</li> <li>includes mounting bracket, streetlight power supply, and surge suppressor</li> </ul>
	620-00708-01	horizontal pole mount with 20-foot / 6-meter cable to photoelectric tap
	620-00708-02	horizontal pole mount with 3-foot / 1-meter cable to photoelectric tap
<b>Power Cord</b>		to be purchased for use with Indoor Power Supply w/ PoE Injector
	171-R0005-01	IEC320-C13 plug for Americas
	171-R0005-02	IEC320-C13 plug for UK
	171-R0005-03	IEC320-C13 plug for Europe
	171-R0005-05	IEC320-C13 plug for Australia
	171-R0005-06	IEC320-C13 plug for Latin America

## PREPARING FOR INSTALLATION

### Required Equipment

- A power supply, typically one of the power supplies listed as a Gateway accessory. For all outdoor installations, the PSU-1024-33A SecureMesh Power Service Unit is recommended unless an Uninterruptible Power Supply is available.
- A CAT5e, UV-protected, Shielded-Twisted Pair (STP) Ethernet cable with ground wire for connecting the Gateway's Surge Protector to the PoE power supply.
- One of the accessory mounting brackets listed above or provide a mounting bracket including a vertical pole with a 1.25" to 2" diameter that is a minimum of 18" from any structure to the side of the Gateway. The vertical pole must extend a minimum of 5" above a horizontal surface of the bracket.
- A 10 AWG (or larger) ground wire of sufficient length to connect the Gateway to the primary grounding point of the utility structure to which the Gateway will be mounted.
- A magnetic level to ensure the Gateway is plumb.
- Self-fusing rubber insulation and sealing tape such as Scotch® 130C or 2228 Rubber Mastic Tape

### Optional Equipment

The following equipment is required to support optional manual provisioning of the Gateway:

- A computer connected to the same Ethernet network as the SecureMesh Gateway. The Gateway's default IP address is 192.168.0.2.
- A CAT5e, Ethernet cable for connecting the Gateway's Surge Protector to the PoE power supply.

## Installation Location

In general, a SecureMesh Gateway should be installed in a location that will not obstruct the radio signals to and from the SecureMesh Gateway. The SecureMesh Gateway should be installed in a location that meets all of the following guidelines:

- Installation and wiring of the SecureMesh Gateway must conform to all local electrical codes and ordinances.
- The installation location must be either owned by the utility or the utility must have access rights to the location.
- The installation location must be able to provide adequate power. Note that the 24V Power Service Unit requires 90-265 VAC 50/60 Hz power.
- The Gateway enclosure must be mounted at least 18 feet (5.5 meters) above ground level, although radio performance and coverage will generally improve as the mounting height is increased.
- The installation location must not obstruct radio communications. For example:
  - The mounting structure should not block radio coverage or be adjacent to structures that block radio coverage).
  - The installation location must be clear of thick trees or brush growth upon installation and in the foreseeable future. Foliage in the line of sight with other communicating devices can detrimentally affect radio performance.
  - The Gateway should have an unobstructed view of the sky overhead. The Gateway relies upon GPS (Global Positioning System) signals to establish time synchronization, and the strongest GPS signals are available if the device has an unobstructed view of the sky. Upon startup, the Gateway searches for a GPS signal. If the device cannot detect a signal, it will be unable to complete startup and will not establish wireless connections with other SecureMesh WAN devices.
- As necessary, adequate space must be available to use a bucket truck.
- The installation location must not impede normal maintenance activities (for example, access to the Gateway's associated Power Service Unit to replace the battery).
- If choosing a streetlight pole installation, make sure the streetlight is providing constant power.

## Pre-provisioning

Certain information is necessary in a Gateway other than the factory defaults that must be entered locally using the command line interpreter (CLI). Please refer to the “Trilliant Network Element Management System (NEMS) Administration Guide” (Trilliant document number TLT-CS-ADM-94) for complete information.

The required information to be entered is:

- Netkey
- Management VLAN (if Management VLANs are used)
- VPN Shared secret (if using IPsec VPN. Please refer to Trilliant Technical Note “Use of Virtual Private Networking in the SecureMesh Communications Network”, number DP-0906)

## INSTALLING THE GATEWAY

Physically installing the SecureMesh Gateway involves:

- Mounting the device
- Grounding and protecting the device
- Connecting to a source of power
- Completing the installation

Installation of the Gateway either to a tower or utility-pole or to a streetlight is discussed in the following subsections.



## Utility Pole or Tower Installation

To install a Gateway on a utility pole or a tower, observe the following procedures:

### Mounting the Device

#### Mount the Bracket

- The DK-0029A vertical pole mounting bracket has an extension arm and a mounting pole as shown on the right. Mount the equipment extension arm to the utility pole or tower using bolts or bands.
- Attach a steel mounting pole through the end of the extension arm using the 5/8" attached bolt on the bottom of the pole mount. Firmly tighten.

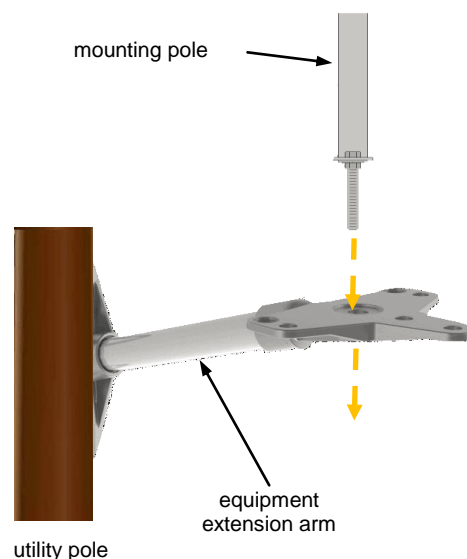

#### Attach The Gateway to the Bracket

Use the provided mounting bracket and appropriate length 1/4" diameter screws that are provided in the accessory kit to attach the SecureMesh Gateway to the mounting pole (see the figure on the right).

Note that screws 1" in length can accommodate a pole diameter up to 1 1/2" while screws 2" in length accommodate a pole diameter of 2 1/8".

The screws should be tightened to 20 foot-pounds (27 Newton-meters) of torque.

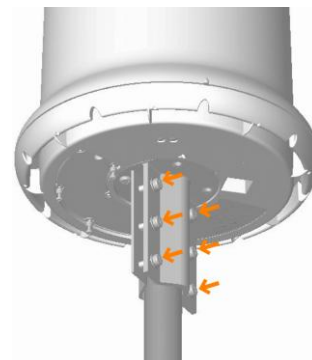

## Grounding and Protecting the Device

### Attach the Surge Protector

The surge protector box should be attached to the bottom of the Gateway. The surge protector will be attached using the ground screw as a pivot point then the box will be swung into place against a mounting bracket screw.

- Remove the ground screw from the base of the device, and then loosen (but do not remove) the screw on the same side of the bracket as the ground screw
- Run the ground screw through the lug of the green ground wire coming from the surge protector and the hole in the surge protector bracket.
- Before tightening the ground screw, remove a section of the insulation on the ground wire which will attach to the ground point on the mounting structure and wrap this section around the ground screw.
- Pivot the box into place such that the other end of the surge protector's mounting bracket touches the loosened screw. Tighten both screws.
- Be sure to connect the ground wire to the grounding point on the mounting structure.
- Run the CAT5e cable under the gasket and plug it into the Ethernet port in the cavity on the device base (see the diagram to the right)

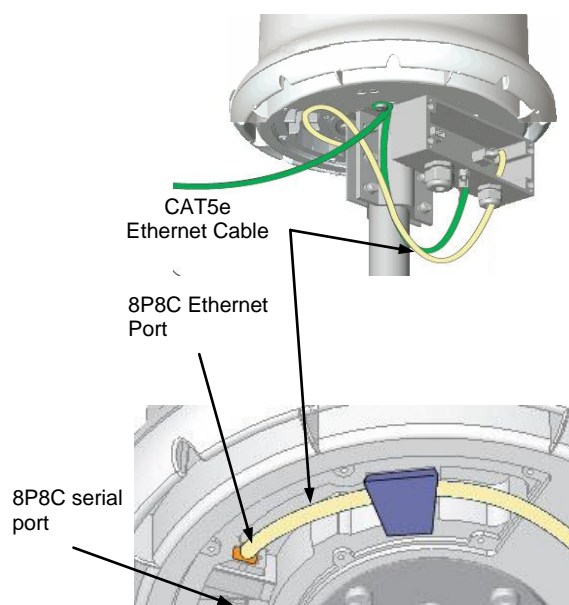
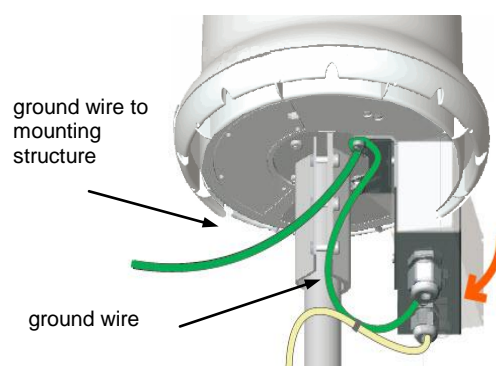
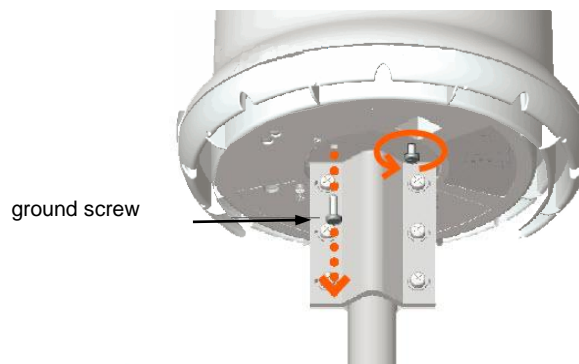

View of underside with cover plate removed

## Connecting the Device to a Source of Power

The Power Service Unit should be used to provide PoE power and battery backup for the Gateway. Please refer to the Power Service Unit Installation Guide for more information (Trilliant document PL-0042A, Installation Guide, SecureMesh 24V PSU).

### Connect the Power over Ethernet (PoE) injector to the Surge Protector.

Both power and data are provided over the Ethernet cable connection to the Gateway.

Always use CAT5e (outdoor CAT5) cable that is shielded (Shielded Twisted Pair – STP), UV protected, with a drain-wire. The Gateway does not have an auto-sensing Ethernet port and therefore, either a straight through cable to a switch or router may be used or a cross-connect cable directly to a computer may be used.

The cable seal gasket (glands) is water-tight and will not allow terminated cables to be passed through. The cable will have to be re-terminated. Therefore, it may be best to perform the termination on the ground before beginning the installation.

A sufficient portion of the cable shielding must be available to be connected to the ground bolt.

- Run an un-terminated CAT5e cable through the open glands on the surge protector.
- Strip the protective coating from the outside of the CAT5e cable to a sufficient length that the shield of the cable may be connected to the ground lug of the surge protector and the twisted pairs may be connected to the RJ45 or the connector block. Connect the cable shield (drain wire) to the internal ground lug.
- Either terminate the cable from the PoE using an RJ45 connector or terminate all eight cables to the terminator block. The screw down terminator block is removable from the base board of the surge protector to ease connections. Please note that the pin-outs of the RJ45 are standard TIA/EIA-568-B. The screw down terminal block wiring diagram is listed on the main board.

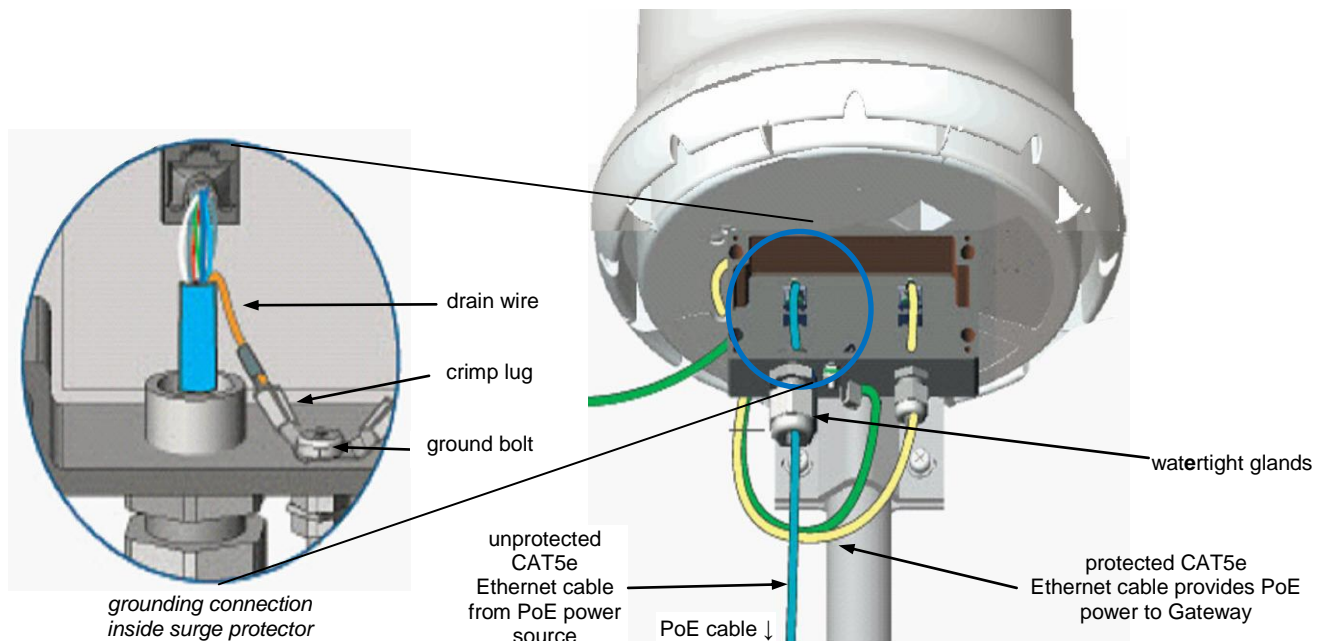

## Completing the installation

- **Check the connections and close the device**

Check to ensure all connections and grounding are proper, and replace the surge protector's cover and the Ethernet connection cover on the base of the Gateway. These screws should be tightened to 15 foot-pounds (20 Newton-meters) of torque.

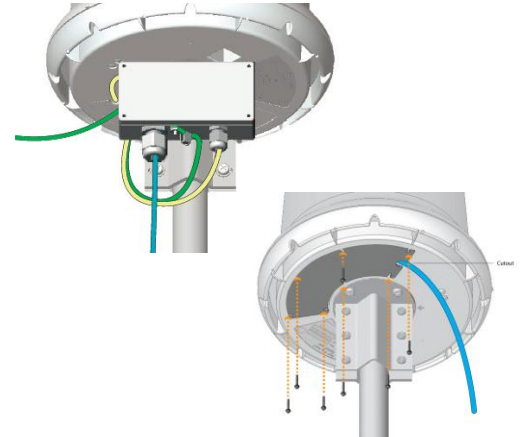

- **Secure the Cabling**

Use sturdy cable ties or Velcro wraps (not included) to secure all the cabling against strain, especially if the installation is subject to high winds.

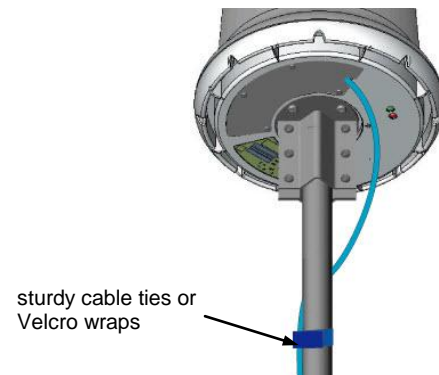

## Streetlight Pole Mounting and Grounding

To install a Gateway on a streetlight, observe the following procedures:

### Mounting the Device

#### Mount the Bracket

- Chose one of the two available Streetlight Installation Kits from the Gateway accessory list. The kits vary only in the length of the cable to attach to the streetlight photo cell.
- If the clamp is not already separate from the main bracket, remove the nuts from the bolts and separate the clamp from the main bracket.
- Place the main bracket over the light pole's horizontal extension arm. Place the clamp on the bolts and secure with the nuts provided as shown on the right. Hand tighten the nuts.
- Make the mounting pipe plumb (straight) by moving the main bracket from side to side and moving the plumb adjustment bracket forward and backward. The accuracy should be checked using a magnetic level. When the mounting pipe is plumb, tighten all nuts.

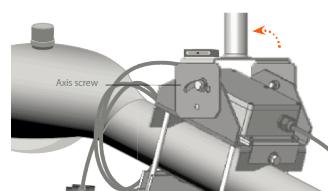
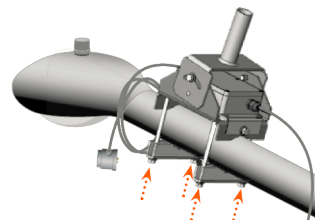
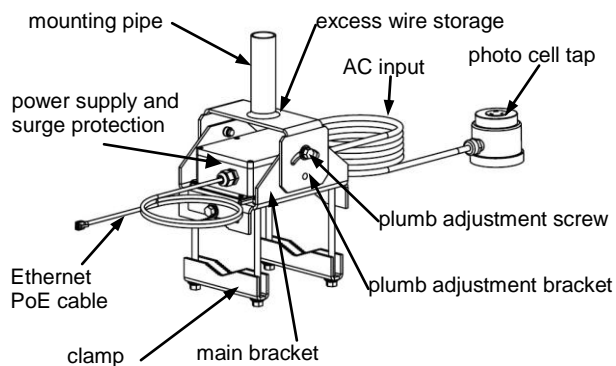

### Attach The Gateway to the Bracket

Use the provided mounting bracket and appropriate length ¼" diameter screws that are provided in the accessory kit to attach the SecureMesh Gateway to the mounting pole (see the figure on the right).

Before tightening, rotate the device to ensure there is ample room for the omnidirectional antennas to clear the mount stand and streetlight pole.

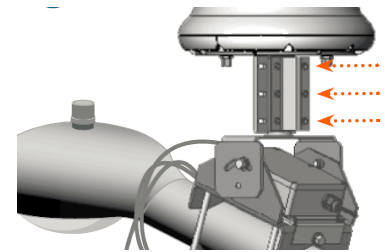

### Attach the Ground Wire

- Connect the Ethernet PoE cable to the Ethernet port at the base of the Gateway, pushing the 8P8C into the socket on the bottom of the Gateway until it locks into place (as shown on the right). The Ethernet PoE cable should be routed through the water protection gasket.
- Loosen the ground screw at the base of the Gateway. Remove a section of the insulation on the ground wire that will attach to the ground point on the streetlight, and wrap this section around the ground screw and tighten the screw.
- If the streetlight is completely metal, attach the other end of the ground wire to the mounting hardware. If the streetlight is a metal arm attached to a wooden pole the ground wire must extend to a proper ground location.

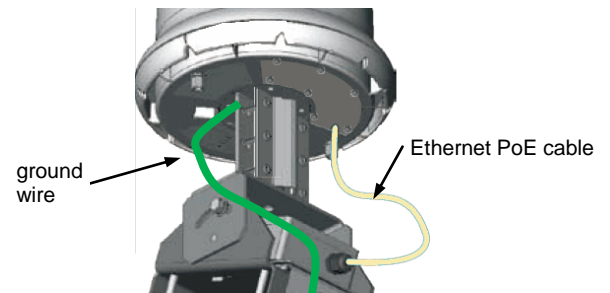
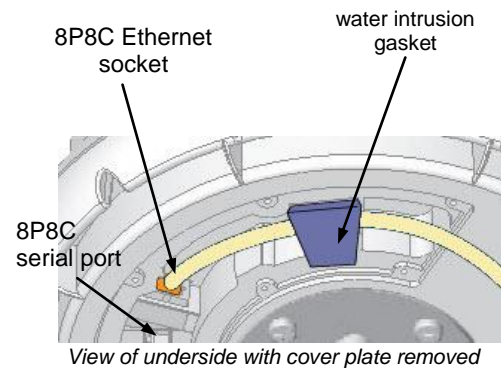

## Connecting the Device to a Source of Power

The Streetlight Installation Kit is to be used with constantly powered streetlights that use standard photocell adapters. The Streetlight Installation Kit is complete with an A/C to D/C power supply that also provides surge protection.

### Connect to Streetlight AC Power

- Locate the photocell on the light pole (usually located on top of the street lamp) and remove it; twisting it counter-clockwise and lifting it from the socket.
- Connect the photocell adapter (power tap) to the photocell socket; twisting clockwise until hand tight.
- Replace the photocell on top of the photocell adapter; twisting clockwise until hand tight.
- Coil any excess cable. Place it in the space provided under the mount stand and secure it.

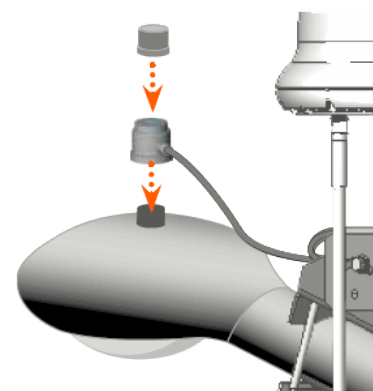
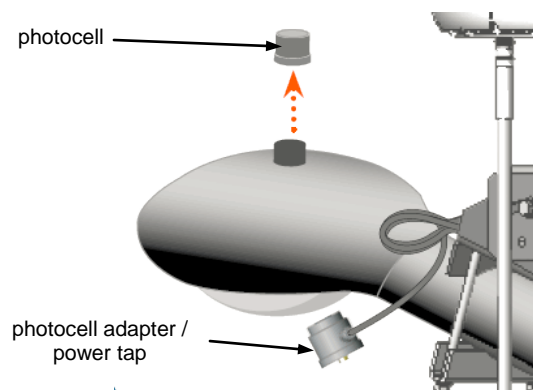

### Completing the Installation

- **Check the connections and close the device**

Check to ensure all connections and grounding are proper and replace the surge protection box cover and the Ethernet cover to the base of the Gateway. These screws should be tightened to 15 foot-pounds (20 Newton-meters) of torque.

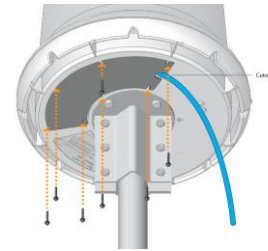

- **Secure the Cabling**

Use sturdy cable ties or Velcro wraps (not included) to secure all the cabling against strain, especially if the installation is subject to high winds.

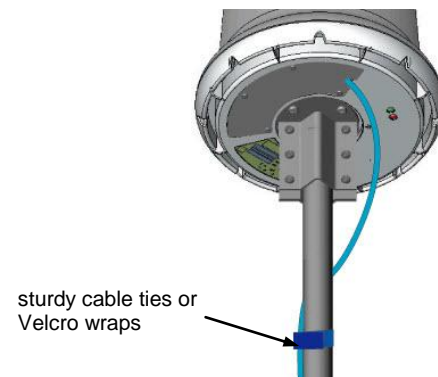



## COMMISSIONING THE GATEWAY

### Configuring the SecureMesh Gateway

Assuming the Gateway is properly pre-provisioned, use of automatic provisioning as described in the “Trilliant Network Element Management System (NEMS) Administration Guide” (Trilliant document number TLT-CS-ADM-94) recommended.

### Monitoring the Power-On Sequence

When power is supplied to the SecureMesh Gateway, it starts a power-on sequence that can be monitored by observing the pair of LED lights on the underside of the device.

The SecureMesh Gateway must have access to a GPS signal to complete its power-on sequence and start making wireless network connections. The power-on sequence takes up to 15 minutes, depending on how quickly the device can acquire a GPS signal.

The tables that follow provide detailed descriptions of device states indicated by the LED lights. When both LED lights are illuminated and steady, the Gateway has successfully connected to the wireless network.

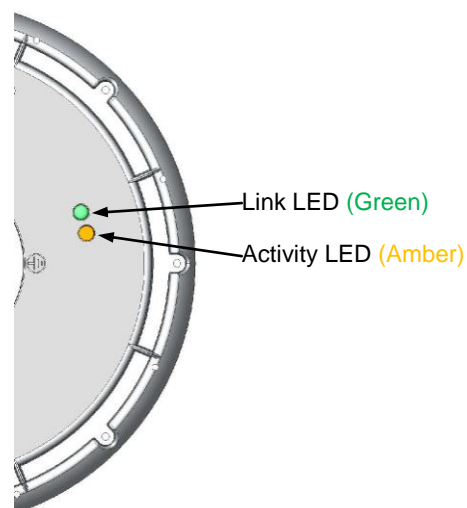

Device State	Link LED (Green)	Activity LED (Amber)
startup in progress	slow staggered blinking of both LEDs	
startup failure	off	on
initializing processor (and acquiring GPS signal)	blinks 4 times; repeats cycle	blinks 4 times; repeats cycle
initialization failure	fast, synchronized blinking of both LEDs	
successful initialization, but failure to locate hello	on	off
successful initialization; heard hello	off	blinking based upon RSSI signal level
successful initialization; link is not optimized, or is in pre-authorization	slow blink	blinking based upon RSSI signal level
successful initialization; link is in standby state on RSSI	fast blink	blinking based upon RSSI signal level
WAN connected and operational	on	on

## APPENDIX A

### Grounding Guidelines

Proper grounding protects both your SecureMesh device and any equipment connected to it. For the surge protection circuitry built into the SecureMesh equipment to be effective, proper grounding of the unit is necessary. Protection is essential if the unit is installed on tall structures or in areas subject to lightning.

Note that the techniques described in this appendix are intended as general guidelines and do not constitute a comprehensive guide covering all installation scenarios. For maximum protection, contact a qualified installation specialist who is familiar with your operating environments. If lightning is a threat in your area, consider a consultation with a lightning and transient protection specialist.

#### General Grounding Strategy

To ensure optimal reliability, properly ground the metal base of the SecureMesh device. The most efficient way to ground the device is to use a 10 AWG or larger wire to connect it to a ground point on the structure or tower.

The three most common grounding points are:

- The primary grounding point or the down lead provided by an existing grounding system at the installation site. For example, the grounding system may be provided by a building's AC electrical system, a streetlight's power system, or as part of a tower structure.
- A 10-foot or longer copper-clad ground rod driven into the earth. At a tower with multiple legs, there will typically be one ground rod per leg and a ground wire loop connecting each of the rods as shown in the accompanying picture.
- A cold-water pipe. Make sure it is well connected to earth.

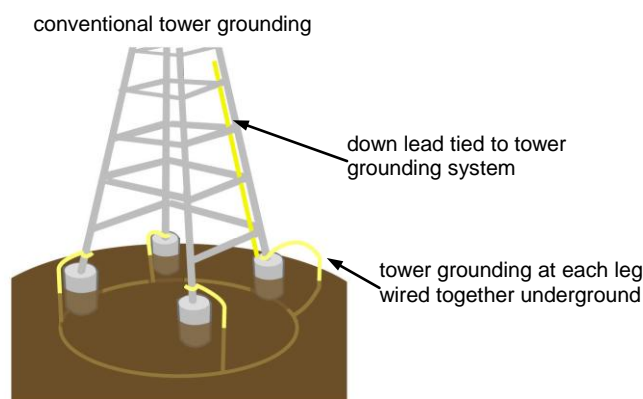

## Making Robust and Lasting Connections

Regardless of the grounding point you use, make sure the connections are capable of retaining low resistance and integrity over time and with exposure to the elements by use of an antioxidant compound. For protection against corrosion and rust, wrap all connections with a product such as Scotch® 130C or 2228 Rubber Mastic Tape.

## Grounding Checklist

When grounding a SecureMesh WAN device, use the following checklist to confirm that your installation is adequately protected from power surges and lightning.

- Install all lightning and surge protection devices in accordance with UL 96A installation requirements for lightning protection systems and the NFPA 780 standard for lightning protection.
- Connect a ground wire from the SecureMesh WAN device to a ground system on the utility pole, tower, or building.
- When using outdoor Ethernet cable, use UV protected, Shielded Twisted Pair (STP) CAT5e cabling that includes a drain wire. The drain wire and cable shield should be connected to the appropriate ground location on the SecureMesh WAN device; typically the ground lug inside the surge protector or the ground point on the outside of the device. Leave the other end of the drain wire at the power source unconnected.
- Use the proper size down lead to connect the SecureMesh WAN device on a roof or tower to the ground system.
- Whenever possible, verify that all points of the ground system are tied together with less than 5 ohms resistance between any two points.

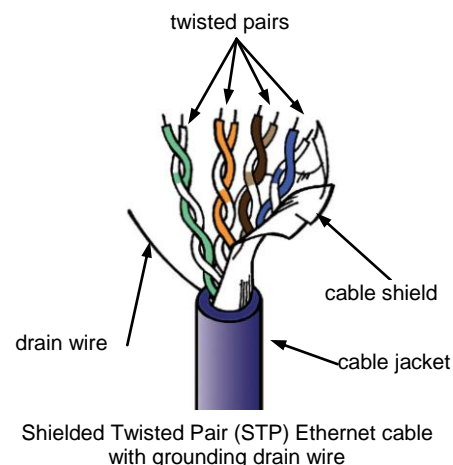

## For Towers and Rooftops

- Use the proper size down lead to connect the SecureMesh WAN device on a roof or tower to the ground system.
- Run the CAT5e cable inside the tower structure, tying the cable to the tower leg at every 4 feet of length. For increased protection, run the CAT5e cable through metallic conduit installed on the tower.

## APPENDIX B

### Regulatory Information

#### Federal Communications Commission (FCC) compliance notices

This section includes the following FCC statements for the GATE-1100-A, SP-6930-A and related SecureMesh™ and SkyPilot by Trilliant Gateways:

- FCC ID: RV7-5G1100 (Applies to GATE-1100-A and SP-6930-A)
- Class A Interference Statement
- RF Radiation Exposure and Hazard Warning
- Non-Modification Statement
- Deployment Statement

##### Class A Interference Statement

This equipment has been tested and found to comply with the limits for a Class A digital device, pursuant to Part 15 of the FCC Rules. These limits are designed to provide reasonable protection against harmful interference in a commercial installation. This equipment generates, uses, and can radiate radio frequency energy and, if not installed and used in accordance with the instructions, may cause harmful interference to radio communications. However, there is no guarantee that interference will not occur in a particular installation. If this equipment does cause harmful interference to radio or television reception, which can be determined by turning the equipment off and on, the user is encouraged to try to correct the interference by one or more of the following measures:

- Reorient or relocate the receiving antenna.
- Increase the separation between the equipment and receiver.
- Connect the equipment into an outlet on a circuit different from that to which the receiver is connected.
- Consult the dealer or an experienced radio/TV technician for help.

##### FCC Caution:

This device complies with Part 15 of the FCC Rules. Operation is subject to the following two conditions: (1) This device may not cause harmful interference, and (2) this device must accept any interference received, including interference that may cause undesired operation.

##### RF Radiation Exposure & Hazard Statement

To ensure compliance with FCC RF exposure requirements, this device must be installed in a location such that the antenna of the device will be greater than 20 cm (8 in.) away from all persons. Using higher gain antennas and types of antennas not covered under the FCC certification of this product is not allowed. Installers of the radio and end users of the product must adhere to the installation instructions provided in this manual. This transmitter must not be co-located or operated in conjunction with any other antenna or transmitter.

##### Non-Modification Statement

Use only the supplied internal antenna. Unauthorized antennas, modifications, or attachments could damage the GATE-1100-A and SP-6930-A and related SecureMesh™ and SkyPilot by Trilliant products and violate FCC regulations. Any changes or modifications not expressly approved by the party responsible for compliance could void the user's authority to operate this equipment.

##### Deployment Statement

This product is certified for indoor deployment only in the 5150 – 5250 MHz band. Do not install or use this product outdoors in that frequency band in the United States.

##### Dynamic Frequency Selection (DFS) in the 5.0 GHz UNII bands

The GATE-1100-A and SP-6930-A have been prohibited from operating in the 5600 to 5650 MHz frequency band for the US and Canada in order to comply with the DFS requirements as outlined in the FCC Part 15, Subpart E rules.

## Canadian IC Statements

IC: 6028A-5G1100 (Applies to GATE-1100-A and SP-6930-A).

This device complies with ICES-003 and RSS-210 of Industry Canada.

Operation is subject to the following two conditions:

1. This device may not cause interference, and
2. This device must accept any interference, including interference that may cause undesired operation of the device.

Ce dispositif est conforme aux normes NMB003 et CNR-210 d'Industrie Canada.

1. L'utilisation de ce dispositif est autorisée seulement aux conditions suivantes :
2. il ne doit pas produire de brouillage et l'utilisateur du dispositif doit être prêt à accepter tout brouillage radioélectrique reçu, même si ce brouillage est susceptible de compromettre le fonctionnement du dispositif.

### RF Radiation Exposure & Hazard Statement

To ensure compliance with RSS-102 RF exposure requirements, this device must be installed in a location such that the antenna of the device will be greater than 20 cm (8 in.) away from all persons. Using higher gain antennas and types of antennas not covered under the IC certification of this product is not allowed. Installers of the radio and end users of the product must adhere to the installation instructions provided in this manual. This transmitter must not be co-located or operated in conjunction with any other antenna or transmitter.

### Exposition aux radiations RF & Mention de danger

Pour assurer la conformité avec les exigences RSS-102 d'exposition aux RF (Radio Fréquences), cet appareil doit être installé dans un endroit où l'antenne de l'appareil sera située à une distance de plus de 20 cm (8 po) de toutes personnes. L'utilisation d'antennes à gain plus élevé et les types d'antennes qui ne sont pas couverts en vertu de la certification IC de ce produit n'est pas autorisée. Les installateurs de la radio et les utilisateurs du produit final doivent se conformer aux instructions d'installation fournies dans ce manuel. Cet émetteur ne doit pas être co-implanté ou exploité en conjonction avec toute autre antenne ou transmetteur.

### Deployment Statement

This product is certified for indoor deployment only in the 5150 – 5250 MHz band. Do not install or use this product outdoors in that frequency band in Canada.

### Déclaration de déploiement

Ce produit est certifié pour le déploiement à l'intérieur tout en rencontrant les limites de cette bande de fréquences: 5150 - 5250 MHz. Ne pas installer ou utiliser ce produit à l'extérieur au Canada, si cette bande de fréquences ne peut ne peut être rencontrée.



Trilliant Incorporated  
1100 Island Drive, Redwood City, CA 94065 USA  
+1.650.204.5050  
www.trilliantinc.com

Trilliant™, CellReader®, CellGateway™, SecureMesh™, SerViewCom®, UnitySuite™, SkyPilot®, SyncMesh™, the Trilliant logo, and the SkyPilot logo are trademarks of Trilliant Incorporated and/or its subsidiaries. All other trademarks are the property of their respective owners. This material is provided for informational purposes only; Trilliant assumes no liability related to its use and expressly disclaims any implied warranties of merchantability or fitness for any particular purpose.

All specifications, descriptions, and information contained herein are subject to change without prior notice.

Copyright © 2010 Trilliant Incorporated. ALL RIGHTS RESERVED.