

SkyPilot™ by Trilliant® Gateway Pro Installation and Setup

SP-5XXX

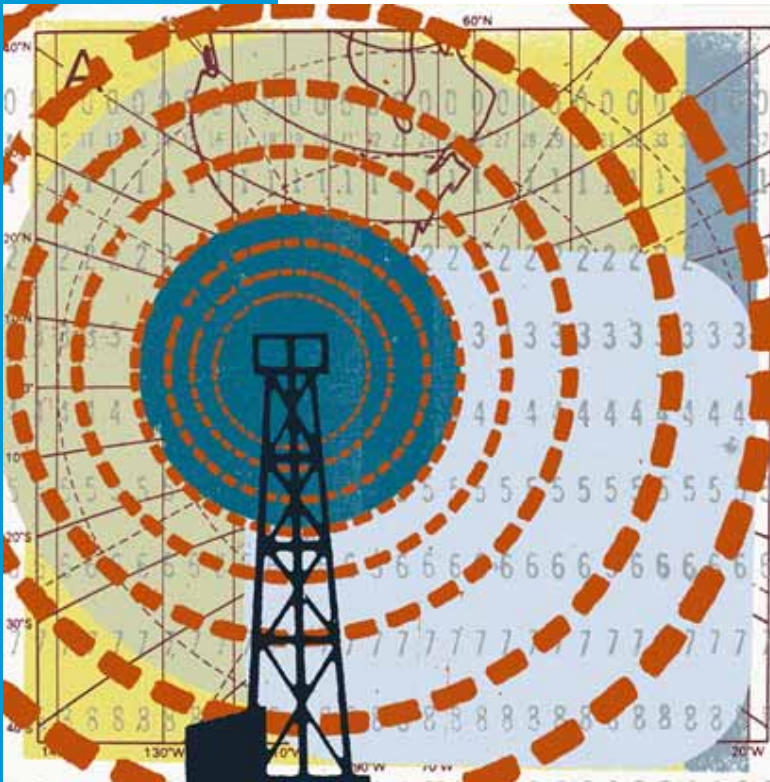

Preliminary

© 2012 Trilliant, Inc. All rights reserved

This publication, or parts thereof, may not be reproduced in any form, by any method, for any purpose.

Product specifications are subject to change without notice. This material is provided for informational purposes only; Trilliant assumes no liability related to its use and expressly disclaims any implied warranties of merchantability or fitness for any particular purpose.

Trilliant Trademarks

Trilliant™, CellReader®, CellGateway™, SecureMesh™, SerViewCom®, UnitySuite™, SkyPilot®, SyncMesh™, the Trilliant logo, and the SkyPilot logo are trademarks of Trilliant Incorporated and/or its subsidiaries.

All other trademarks are the property of their respective owners.

This material is provided for informational purposes only; Trilliant assumes no liability related to its use and expressly disclaims any implied warranties of merchantability or fitness for any particular purpose.

All specifications, descriptions, and information contained herein are subject to change without prior notice.

Third-Party Trademarks

Java and all Java-based trademarks and logos are trademarks or registered trademarks of Sun Microsystems, Inc. in the United States and other countries.

MySQL is a registered trademark of MySQL AB in the United States, the European Union, and other countries.

All other designated trademarks, trade names, logos, and brands are the property of their respective owners.

Third-Party Software Program Credits

This product includes software developed by the Apache Software Foundation (<http://www.apache.org/>), licensed under the Apache License.

This product includes the DHCP Server software from Internet Systems Consortium, licensed under the DHCP License. The DHCP Server software is copyright © 2004 Internet Systems Consortium, Inc. ("ISC"). Copyright © 1995–2003 Internet Software Consortium. All rights reserved. Redistribution and use in source and binary forms, with or without modification, are permitted provided that the following conditions are met: 1. Redistributions of source code must retain the above copyright notice, this list of conditions and the following disclaimer. 2. Redistributions in binary form must reproduce the above copyright notice, this list of conditions and the following disclaimer in the documentation and/or other materials provided with the distribution. 3. Neither the name of ISC, ISC DHCP, nor the names of its contributors may be used to endorse or promote products derived from this software without specific prior written permission. THIS SOFTWARE IS PROVIDED BY INTERNET SYSTEMS CONSORTIUM AND CONTRIBUTORS "AS IS" AND ANY EXPRESS OR IMPLIED WARRANTIES, INCLUDING, BUT NOT LIMITED TO, THE IMPLIED WARRANTIES OF MERCHANTABILITY AND FITNESS FOR A PARTICULAR PURPOSE ARE DISCLAIMED. IN NO EVENT SHALL ISC OR CONTRIBUTORS BE LIABLE FOR ANY DIRECT, INDIRECT, INCIDENTAL, SPECIAL, EXEMPLARY, OR CONSEQUENTIAL DAMAGES (INCLUDING, BUT NOT LIMITED TO, PROCUREMENT OF SUBSTITUTE GOODS OR SERVICES; LOSS OF USE, DATA, OR PROFITS; OR BUSINESS INTERRUPTION) HOWEVER CAUSED AND ON ANY THEORY OF LIABILITY, WHETHER IN CONTRACT, STRICT LIABILITY, OR TORT (INCLUDING NEGLIGENCE OR OTHERWISE) ARISING IN ANY WAY OUT OF THE USE OF THIS SOFTWARE, EVEN IF ADVISED OF THE POSSIBILITY OF SUCH DAMAGE.

This product includes the FTP Server software from vsftpd (<http://vsftpd.beasts.org/>), licensed under the GNU General Public License.

This product includes Java software from Sun Microsystems, licensed under Sun Microsystems' Binary Code License Agreement. Copyright 2003, Sun Microsystems, Inc. All rights reserved. Use is subject to license terms. Sun, Sun Microsystems, the Sun logo, Solaris, Java, the Java Coffee Cup logo, J2SE, and all trademarks and logos based on Java are trademarks or registered trademarks of Sun Microsystems, Inc. in the U.S. and other countries.

This product includes JBOSS Version 3.2.3 software from JBoss, licensed under the GNU Lesser General Public License. Some bundled products in JBOSS are licensed under the Apache License.

This product contains Java Telnet Application (JTA 2.0).

This product contains the MibBrowser software from Mibble.

This product includes software the copyright of which is owned by and licensed from MySQLAB.

This product includes software developed by the OpenSSL Project for use in the OpenSSL Toolkit. (<http://www.openssl.org/>). Copyright (c) 1998–2005 The OpenSSL Project. All rights reserved. Redistribution and use in source and binary forms, with or without modification, are permitted provided that the following conditions are met: 1. Redistributions of source code must retain the above copyright notice, this list of conditions and the following disclaimer. 2. Redistributions in binary form must reproduce the above copyright notice, this list of conditions and the following disclaimer in the documentation and/or other materials provided with the distribution. 3. All advertising materials mentioning features or use of this software must display the following acknowledgment: "This product includes software developed by the OpenSSL Project for use in the OpenSSL Toolkit. (<http://www.openssl.org/>)" 4. The names "OpenSSL Toolkit" and "OpenSSL Project" must not be used to endorse or promote products derived from this software without prior written permission. For written permission, please contact openssl-core@openssl.org. 5. Products derived from this software may not be called "OpenSSL" nor may "OpenSSL" appear in their names without prior written permission of the OpenSSL Project. 6. Redistributions of any form whatsoever must retain the following acknowledgment: "This product includes software developed by the OpenSSL Project for use in the OpenSSL Toolkit (<http://www.openssl.org/>)". THIS SOFTWARE IS PROVIDED BY THE OPENSSL PROJECT "AS IS" AND ANY EXPRESSED OR IMPLIED WARRANTIES, INCLUDING, BUT NOT LIMITED TO, THE IMPLIED WARRANTIES OF MERCHANTABILITY AND FITNESS FOR A PARTICULAR PURPOSE ARE DISCLAIMED. IN NO EVENT SHALL THE OPENSSL PROJECT OR ITS CONTRIBUTORS BE LIABLE FOR ANY DIRECT, INDIRECT, INCIDENTAL, SPECIAL, EXEMPLARY, OR CONSEQUENTIAL DAMAGES (INCLUDING, BUT NOT LIMITED TO, PROCUREMENT OF SUBSTITUTE GOODS OR SERVICES; LOSS OF USE, DATA, OR PROFITS; OR BUSINESS INTERRUPTION) HOWEVER CAUSED AND ON ANY THEORY OF LIABILITY, WHETHER IN CONTRACT, STRICT LIABILITY, OR TORT (INCLUDING NEGLIGENCE OR OTHERWISE) ARISING IN ANY WAY OUT OF THE USE OF THIS SOFTWARE, EVEN IF ADVISED OF THE POSSIBILITY OF SUCH DAMAGE.

This product includes libraries developed by Eric Young and is licensed under the Original SSLeay License. This product includes cryptographic software written by Eric Young (eay@cryptsoft.com). This product includes software written by Tim Hudson (tjh@cryptsoft.com). Copyright (C) 1995–1998 Eric Young (eay@cryptsoft.com). All rights reserved. Redistribution and use in source and binary forms, with or without modification, are permitted provided that the following conditions are met: 1. Redistributions of source code must retain the copyright notice, this list of conditions and the following disclaimer. 2. Redistributions in binary form must reproduce the above copyright notice, this list of conditions and the following disclaimer in the documentation and/or other materials provided with the distribution. 3. All advertising materials mentioning features or use of this software must display the following acknowledgement: "This product includes cryptographic software written by Eric Young (eay@cryptsoft.com)" The word "cryptographic" can be left out if the routines from the library being used are not cryptographic related -. 4. If you include any Windows specific code (or a derivative thereof) from the apps directory (application code) you must include an acknowledgement: "This product includes software written by Tim Hudson (tjh@cryptsoft.com)". THIS SOFTWARE IS PROVIDED BY ERIC YOUNG "AS IS" AND ANY EXPRESS OR IMPLIED WARRANTIES, INCLUDING, BUT NOT LIMITED TO, THE IMPLIED WARRANTIES OF MERCHANTABILITY AND FITNESS FOR A PARTICULAR PURPOSE ARE DISCLAIMED. IN NO EVENT SHALL THE AUTHOR OR CONTRIBUTORS BE LIABLE FOR ANY DIRECT, INDIRECT, INCIDENTAL, SPECIAL, EXEMPLARY, OR CONSEQUENTIAL DAMAGES (INCLUDING, BUT NOT LIMITED TO, PROCUREMENT OF SUBSTITUTE GOODS OR SERVICES; LOSS OF USE, DATA, OR PROFITS; OR BUSINESS INTERRUPTION) HOWEVER CAUSED AND ON ANY THEORY OF LIABILITY, WHETHER IN CONTRACT, STRICT LIABILITY, OR TORT (INCLUDING NEGLIGENCE OR OTHERWISE) ARISING IN ANY WAY OUT OF THE USE OF THIS SOFTWARE, EVEN IF ADVISED OF THE POSSIBILITY OF SUCH DAMAGE.

This product includes SNMP software from WestHawk, licensed under the WestHawk License.

This product includes JFreeCharts from <http://www.jfree.org/>, licensed under GNU Lesser General Public License.

This product includes JasperReports from <http://jasperreports.sourceforge.net/index.html>, licensed under GNU Lesser Public License.

Contents

About This Guide	v
Audience and Purpose	vi
How This Guide Is Organized	vi
Conventions Used in This Guide	vii
Chapter 1 Introduction	1
Solution Overview	2
Mesh Network.	2
SkyPilot Gateway & SkyPilot Gateway Pro	4
SkyPilot Extender, Extender DualBand	4
SkyPilot Connector.	5
Chapter 2 Your SkyPilot Gateway Pro Kit	7
Kit Contents	8
Required Tools and Supplies.	9
Chapter 3 Planning Your SkyPilot Network	11
Deployment Process Overview	12
Network Planning	12
Co-Located SkyPilot Gateway Pro Devices	16
Chapter 4 Configuring the SkyPilot Gateway Pro.	17
Provisioning	17
Cabling	18
Powering Up.	21
Configuring the SkyPilot Gateway Pro.	22
Configuring Adjacent SkyPilot Gateway Pros	26
Chapter 5 Installing the SkyPilot Gateway Pro	27
Install Devices	27
Mounting.	28
Chapter 6 Verifying Connectivity	33
Confirming SkyPilot Gateway Pro Connectivity	33
Confirming SkyPilot Extender and SkyPilot Connector Connectivity	35
Confirming SkyPilot Extender DualBand Access Point Connectivity	37
Troubleshooting	39
Appendix A Grounding Guidelines	41
General Grounding Strategy.	41
Adding Surge Protection	43
Grounding Checklist.	43
Appendix B FCC Statements	45
FCC Class A Notice	45
FCC Class B Notice	45
Maximum Permissible Exposure	46
FCC 15.203 statement	46

Regulatory Statements for Canada	46
Appendix C Specifications	49
Appendix D Pinouts	53
RJ-45 Pins	53
DB-9 Adapter	54

About This Guide

This guide explains how to install and set up a SkyPilot™ Gateway™ Pro device. It assumes administrator-level knowledge of IP networks and a familiarity with configuring wireless devices.

Chapter Highlights

- Audience and purpose
- How this guide is organized
- Conventions used in this guide

Audience and Purpose

This guide provides directions for installing and setting up a SkyPilot Gateway Pro.

This guide assumes administrator-level knowledge of IP networks and a familiarity with configuring wireless devices.

How This Guide Is Organized

This guide is organized as follows:

- Chapter 1, "Introduction," provides an overview of the SkyPilot solution, describes the SkyPilot devices, and then illustrates how they combine to form a mesh network.
- Chapter 2, "Your SkyPilot Gateway Pro Kit," provides the information you need before you begin your installation.
- Chapter 3, "Planning Your SkyPilot Network," provides an overview of network planning guidelines and procedures
- Chapter 4, "Configuring the SkyPilot Gateway Pro," describes the process for bringing up a SkyPilot Gateway Pro unit for the first time.
- Chapter 5, "Installing the SkyPilot Gateway Pro," explains how to mount the unit in the field.
- Chapter 6, "Verifying Connectivity," describes the steps needed to verify proper operation of each device.
- Appendix A, "Grounding Guidelines," provides direction on protecting your SkyPilot device with proper grounding and surge protection.
- Appendix B, "FCC Statements," provides the FCC radio frequency interference statements for the SkyPilot Gateway Pro devices.
- Appendix C, "Specifications," give the mechanical and electrical specifications of the SkyPilot Gateway Pro.
- Appendix D, "Pinouts," provides pinouts for connectors and adapters to connect to the Ethernet interface port labeled "CPE" on the SkyPilot Gateway Pro power supply and the device's serial interface.

Conventions Used in This Guide

This section describes the text and syntax conventions used throughout this guide.

Text Conventions

This guide uses the following text conventions:

- *Italic* is used to introduce new terms.
- **Bold** is used to indicate what you click or type in a graphical user interface (for example, commands names or text being entered). In examples showing user interaction with the command-line interface, bold is used to indicate user input as opposed to command output.
- A **monospace** font is used for code elements (variable names, data values, function names, and so forth), command lines, scripts, and source code listings.
- **Italic-monospace** is used for replaceable elements and placeholders within code listings.

Syntax Conventions

This guide uses the following conventions when showing syntax:

- Angle brackets, “<” and “>”, enclose mandatory elements. You must enter these elements. For example:
`ping <IP-address>`
- Square brackets, “[” and “]”, enclose optional elements. You can omit these elements. For example:
`show filter [filter-table-number]`
Square brackets are also used to show the current value of parameters in the output of some commands.
- A vertical bar, “|”, separates choices. For example:
`show bridge [cache | port]`

Introduction

This chapter provides an overview of the SkyPilot Networks solution, describes the SkyPilot devices, and then illustrates how they combine to form a mesh network.

Chapter Highlights

- Solution Overview
- Mesh Network
- SkyPilot Gateway and SkyPilot Gateway Pro

Solution Overview

A SkyPilot Network delivers a wireless, end-to-end broadband solution that seamlessly supports high-capacity, high-coverage mesh networks. Designed for managed-access networks and service providers, the SkyPilot network takes broadband wireless the “last mile” with a cost-effective, robust infrastructure solution.

Based on a high-performance architecture that includes intelligent antenna arrays, the SkyPilot network delivers a dynamic broadband solution.

SkyPilot wireless devices are simple to install and easily fit into any type of wireless environment—metropolitan, business, or home.

The auto-discovery and rapid provisioning features of a SkyPilot wireless mesh network can greatly reduce deployment and maintenance costs. Multiple topology options and network scalability create intriguing options for rapidly expanding a metro Wi-Fi customer base.

Mesh Network

The typical configuration for a SkyPilot network is a mesh topology, which uses SkyPilot Extenders to extend range and add network flexibility. In a mesh configuration, subscribers can either connect directly to the SkyPilot Gateway Pro or connect indirectly via SkyPilot Extenders (see Figure 1-1). In addition to adding range, a mesh network allows connections from locations where obstructions prevent line-of-sight access to a SkyPilot Gateway Pro.

Mesh networks are ideal for dense subscriber environments, for filling in coverage “holes,” and for reaching subscribers in areas where RF communication is obstructed by hills, trees, buildings, or other obstacles.

Figure 1-1. SkyPilot wireless mesh network

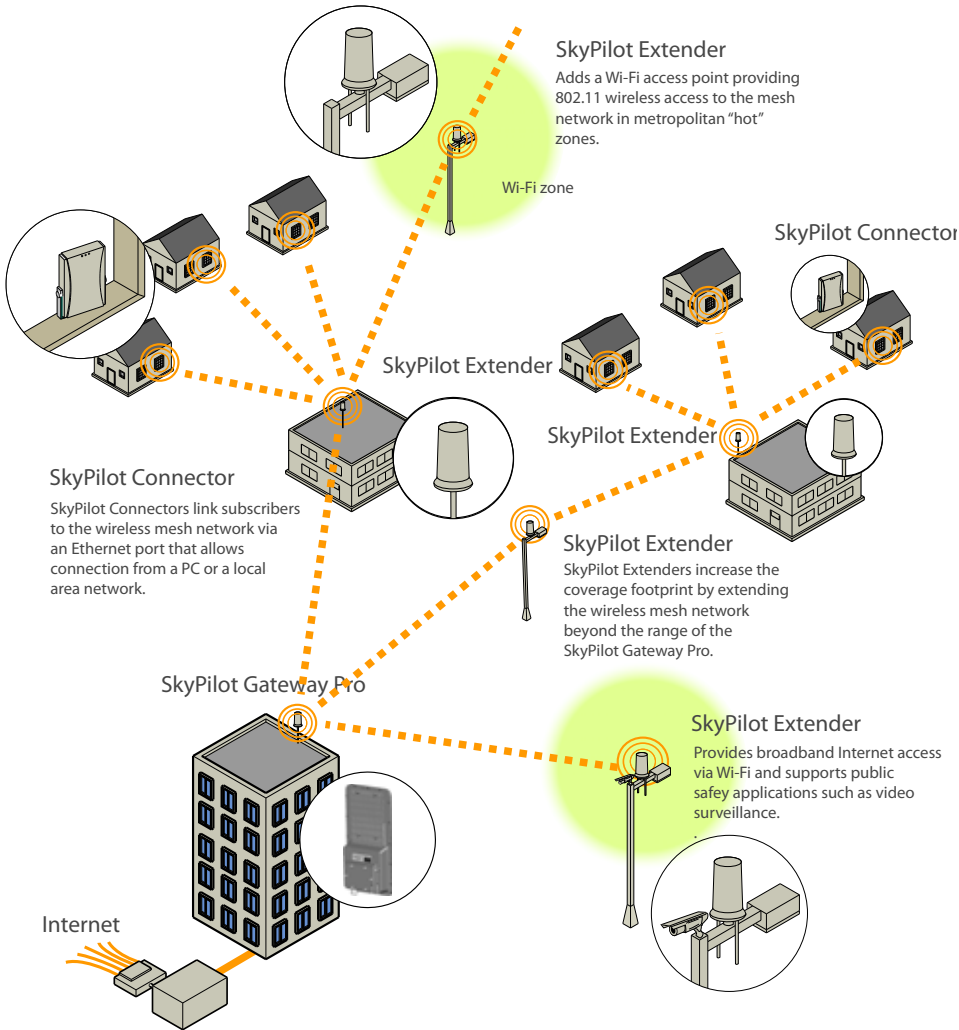

SkyPilot Gateway & SkyPilot Gateway Pro

The SkyPilot Gateway and Gateway Pro operate as a base stations for a wireless mesh network. They provide an interface between the wired infrastructure and a wireless network of subscribers who enjoy secure, high-speed access to the Internet.

A SkyPilot wireless network requires at least one SkyPilot Gateway or SkyPilot GatewayPro, for operation. If necessary, you can add additional SkyPilot Gateway Pros to increase network capacity or provide redundancy.

A SkyPilot Gateway or Gateway Pro resides at a location with easy access to wired infrastructure—usually a POP (point of presence) or data center.

The SkyPilot Gateway Pro uses an advanced, second-generation electronically steerable antenna to deliver higher overall throughput. In addition, it XXX...

SkyPilot Extender, Extender DualBand

SkyPilot Extenders and SkyPilot Extender DualBands provide a cost-effective way to extend range and balance network loads by operating as repeaters to extend the wireless range of a SkyPilot Gateway Pro (see Figure 1-1). You can add a SkyPilot Extender device to your network to expand your coverage footprint and provide redundancy through SkyPilot’s mesh networking features. SkyPilot Extender devices, including DualBands, can provide subscribers with a direct connection to the wireless network via the device’s Ethernet port.

SkyPilot Extender DualBand is a dual-radio solution that combines SkyPilot’s long-range, high-capacity 5 GHz mesh backhaul with a high-powered 2.4 GHz 802.11b/g access point that allows service providers and municipalities to offer standard Wi-Fi services, for targeted hot zones or ubiquitous coverage patterns.

For optimum performance, install the SkyPilot Extender in an elevated location such as a roof, tower, or utility pole.

SkyPilot Connector

SkyPilot Connectors link your subscribers to the SkyPilot wireless network. An Ethernet port on the device allows a connection to a subscriber's computer, or to a local area network (LAN) via a data switch or router. Designed for installation by the service provider, the SkyPilot Connector attaches to an external structure such as an eave, roof, or pole.

The SkyPilot Connector DualBand offers the same features as a SkyPilot Connector, plus a Wi-Fi access point that enables service providers and municipalities to provide standard 802.11 wireless access, for targeted hot zones, or for dense coverage patterns.

Your SkyPilot Gateway Pro Kit

Your SkyPilot Gateway Pro kit provides the basic equipment you need to install the device and configure it for operation on a SkyPilot wireless mesh network. This chapter describes that equipment and lists additional items you should have on hand before starting installation.

Chapter Highlights

- Kit Contents
- Required Tools and Supplies

Kit Contents

The contents of the SkyPilot Gateway Pro kit are listed below:

- SkyPilot Gateway Pro unit
- Power supply. This unit is both a power supply and a power injector. Your SkyPilot Gateway Pro is powered over Ethernet, and you may use either the included power supply or your own PoE PSE equipment. Note that the power supply is not outdoor-rated; it should be mounted indoors or in a suitable enclosure.
- DB-9 to RJ-45 adapter. This can be used to adapt the cat-5 serial port cable to a DB-9 serial port.
- GPS antenna
- GPS antenna mounting bracket
- Weatherproof cable connector housing
- Mounting hardware, consisting of:
 - two sets of two-piece pole clamps
 - double-hinged mounting bracket
 - single-hinged mounting bracket
 - Nuts, bolts, and washers

Figure 2-1. SkyPilot Gateway Pro (rear view)



Required Tools and Supplies

Before starting installation, you also need the following:

- For basic mounting:
 - 7/16" wrench
 - 9/16" wrench
 - Phillips screwdriver
 - Loc-tite or other thread-locking compound
- For pole mounting:
 - Magnetic level
 - Steel pole between 1 1/4" and 2 1/8" in diameter
- For network cabling:
 - Spool of CAT-5 shielded network cable, outdoor-rated.
 - RJ-45 straight through cable for a serial connection to a console (standard CAT-5 patch cable will work)

NOTE In theory, you should never need to service a unit once it is deployed. However, should you need to do so, access to the serial port may be required. Many installers find it prudent to run a serial cable from the SkyPilot to a location that gives easier access.

- Crossover cable (for connecting to a an access point, switch, or router)
- RJ-45 unshielded connectors (connectors without a protective plastic boot are preferred; they fit through the cable clamp more easily.)
- RJ-45 crimping tool
- Open-end wrench, adjustable or 1-3/6" (30 mm)
- Surge protection device (strongly recommended)
- For configuration:
 - Computer with a serial port, a terminal emulation program, a network interface card, and a Web browser. A laptop recommended for convenience.

Planning Your SkyPilot Network

This chapter provides instructions for configuring the SkyPilot Gateway Pro and then performing the physical installation.

Chapter Highlights

- Planning your installation
- GPS and the SkyPilot Gateway Pro

Deployment Process Overview

Table 3-1 summarizes the stages of SkyPilot network planning and deployment.

Table 3-1. Stages of deployment

Stage	Description
Identify equipment locations	Identify and prepare locations for installation.
Choose an operating frequency	Choose a “clean” center frequency that permits interference-free operation of devices.
Provision SkyPilot devices	Choose a provisioning mode for the devices: manual or automatic. Provision the devices. (For automatic provisioning, install operating system and SkyPilot EMS software.)
Install SkyPilot devices	Install the devices, beginning with SkyPilot Gateway Pro devices and building out.
Verify connectivity	Confirm that the SkyPilot Gateway Pro is online. Confirm that installed SkyPilot Connectors and SkyPilot Extenders have established a link with the SkyPilot Gateway Pro. Review link characteristics and network performance.

Network Planning

Identify Equipment Locations

Deployment of a SkyPilot network starts with a site survey to help you identify the devices you need and choose optimum locations for installation.

Identifying locations for the SkyPilot Gateway Pro and SkyPilot Connectors is straightforward. For the SkyPilot Gateway Pro, location depends on proximity to existing network infrastructure and site elevation. SkyPilot Connectors are placed at subscriber sites—homes or offices.

When choosing a site for the SkyPilot Gateway Pro, consider the radio frequency (RF) environment and the physical layout of the area. Trees, buildings, and hills can attenuate or block a wireless signal. When assessing a site, examine the overall topology of the wireless path for obstructions—both existing and planned—as well as seasonal changes of foliage and tree growth. The RF environment is dynamic, and can deteriorate over time as structures appear or are relocated.

Plan to use test signals to determine the suitability of the link topology for target applications. Interference on your desired frequency results in overlapping signals, causing outages or intermittent drops in throughput.

Once you've identified a potential site, use a topographic map or path profile software to ensure that terrain or obstacles will not interfere with the links. Numerous online tools for RF path analysis are available. These can also help identify possible Fresnel zone issues.

Your site survey should include an RF scan to identify available frequencies. You should also check your preferred frequency at all locations. A frequency that's clear at one location may be crowded at another. Frequency planning is a critical factor in planning and implementing a wireless network. (For device operating frequencies, see Appendix C, "Specifications.")

The site survey process should be ongoing. To verify that a site is relatively free of interference, make site audits every six to twelve months, scheduling regular maintenance visits to coincide with the site audits.

In a typical wide area wireless mesh network, you'll install a SkyPilot Gateway Pro on the side of a building. The direct coverage area of the SkyPilot Gateway Pro is usually proportional to the height of the installation.

You can also set up a SkyPilot Gateway Pro for use in smaller-scale networks—for example, a high-capacity business, an academic campus interconnection, or a local access network.

SkyPilot Extenders are far more flexible in terms of location. If you determine that you need SkyPilot Extenders in order to reach all your customers or add redundancy, you must also identify optimum locations for their installation.

GPS and the SkyPilot Gateway Pro

The SkyPilot Gateway Pro uses a GPS (Global Positioning System) signal for synchronization with other SkyPilot devices on the network. The strongest GPS signal is available outdoors, where the device has an unobstructed view of the sky. (For indoor installations, such as for configuration and testing, the optimum location is on a windowsill or other opening with access to the sky.) A separate GPS antenna is included with your SkyPilot Gateway Pro. It should be mounted above the SkyPilot Gateway Pro, where it has a clear view of the sky.

Upon startup, a SkyPilot Gateway Pro searches for a GPS signal, and if the device can't detect a signal, it will be unable to complete startup and won't establish wireless connections with other devices. You can configure a SkyPilot Gateway Pro even if the device can't detect a GPS signal. While the device is searching for the GPS signal, press the TILDE key (~) to bypass the search; the device will then proceed through the startup sequence.

NOTE The GPS search should be bypassed only for device configuration, not for standard operation. Without a GPS signal, data will not be reliably transmitted between devices.

The LEDs on the base of the device will confirm availability of a GPS signal.

Guidelines for Adding SkyPilot Extenders

Multiple factors can affect wireless network performance—and dictate the need for SkyPilot Extenders.

- **Physical distance**—Are all your subscriber sites close enough to the SkyPilot Gateway Pro for radio communications? If a SkyPilot Gateway Pro is installed in a high location with a clear sight line to subscriber sites, it can maintain radio communications with SkyPilot Connectors or SkyPilot Extenders at greater distances.
- **Elevation**—There is a correlation between range and device elevation. By installing SkyPilot devices on raised locations, such as towers or tops of buildings, you can avoid RF obstructions that can occur at ground level, thereby extending the range at which the devices can operate normally.

You should install SkyPilot devices at similar elevation because large elevation differences may have an adverse impact on signal strength.

- **Obstructions**—An optimum link between a SkyPilot Gateway Pro and a SkyPilot Connector requires a clear line of sight. Obstructions, both artificial and natural, can reduce effective network range or block radio communications entirely.
- **Type of SkyPilot Connector**—Because it's typically placed outside and at higher elevation than the indoor connector, the outdoor version of the SkyPilot Connector provides greater wireless range than the indoor version.

If there are obstructions blocking subscriber access (as in Figure 3-1) or if there are subscriber sites beyond the distance that a wireless link can maintain, you need to add one or more SkyPilot Extenders to the network.

Figure 3-1. Using a SkyPilot Extender for network extension behind an obstruction

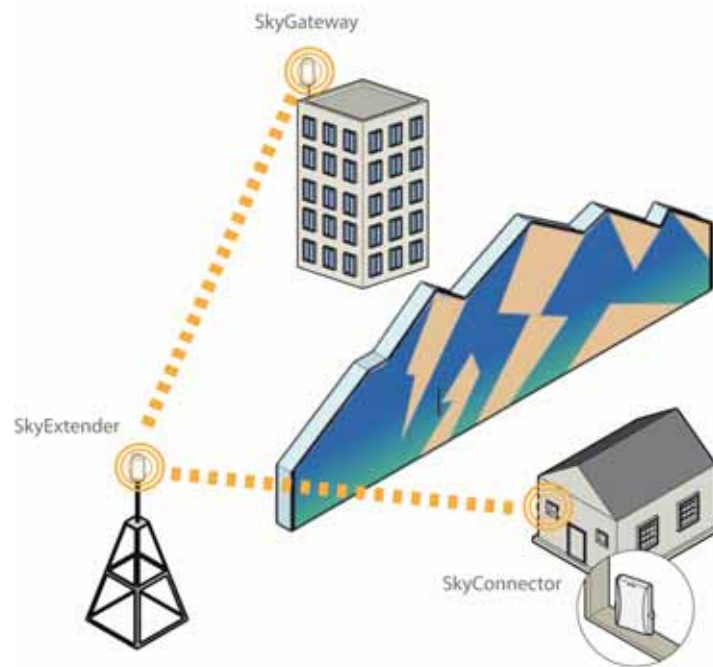

Preparing SkyPilot Extender Sites

If SkyPilot Extenders are required, perform a survey of possible sites before beginning installation. For a detailed discussion of site requirements, refer to *SkyGateway/SkyExtender Installation and Setup*.

For optimum service, attach SkyPilot Extenders to elevated, fixed locations with easy and continuous access to power.

Choose an Operating Frequency

All the devices on a SkyPilot network operate on a single frequency. Before beginning the installation, visit the deployment area and identify an optimum operating frequency. Use a spectrum analyzer or other frequency-planning tool to identify the best available frequency for the SkyPilot wireless network—a “clean” center frequency that permits interference-free operation of devices.

Co-Located SkyPilot Gateway Pro Devices

If you put two of ‘em together, you.....

Configuring the SkyPilot Gateway Pro

This chapter provides instructions for configuring the SkyPilot Gateway Pro and then performing the physical installation.

You should test and configure your SkyPilot Gateway Pro on the bench before deploying it to the field. To do so, you will need to connect cables and the GPS antenna.

Chapter Highlights

- Cabling
- Powering up
- Configuring the SkyPilot Gateway Pro
- Accessing the command-line interface

Provisioning

To provision your SkyPilot Gateway Pro, you must:

- Choose a provisioning mode: automatic or manual.
- Prepare the network infrastructure. For automatic provisioning, you must install SkyPilot software on a supported operating system to create your Network Management System (NMS)

Cabling

Ethernet cabling provides power and data connectivity for the SkyPilot Gateway Pro. Serial cabling provides connectivity for troubleshooting and local configuration.

Figure 4-1. Cable Connections and Mounting Holes

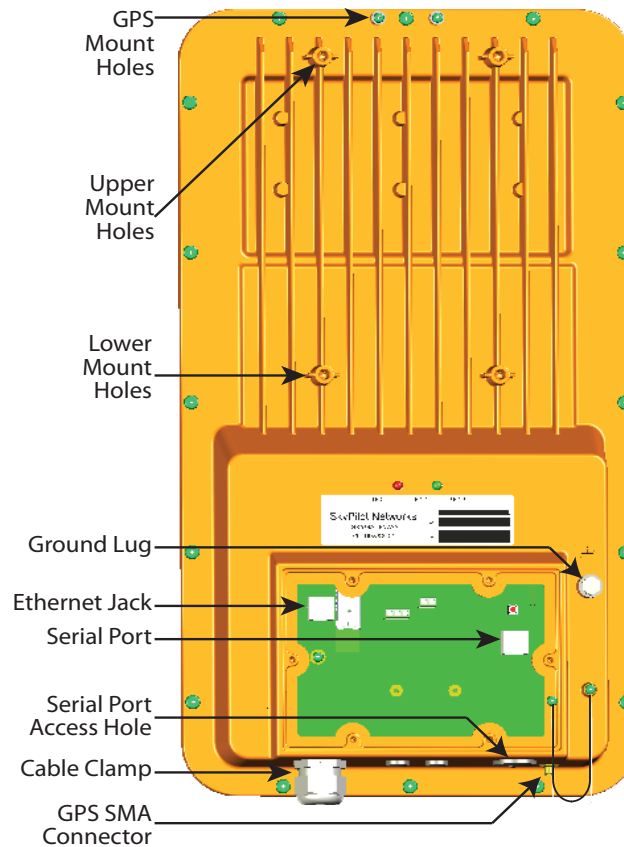

To install cabling for Ethernet, and optionally serial connections:

- 1 Remove the access plate from the back of the unit.
- 2 Connect the Ethernet cable.
 - a Unscrew the black cable clamp and remove the grey rubber gasket.
 - b Thread your Ethernet cable through the black plastic cap and then the grey gasket. In most cases, you can fit the RJ-45 plug through the gasket, or you can thread the cable through first and then crimp on a connector.

- c** Thread the Ethernet cable through the connector body and plug it into the RJ-45 receptacle on the circuit board.
 - d** Makes sure there is a little slack in the cable inside the unit, to act as a strain relief.
 - e** Insert the grey gasket back into the connector, and then tighten the cap until the cable is securely held.
- 3** Connect the serial cable. This is done in the same manner as the Ethernet cable. You must first remove the plug and installed the supplied cable clamp. The plug unthreads; use a large flat-blade screwdriver or a coin.
- 4** Re-attach the cover.
- 5** Use cable ties or Velcro wraps to secure all the cabling against strain.

Figure 4-2. Exploded View of Cable Clamp Assembly

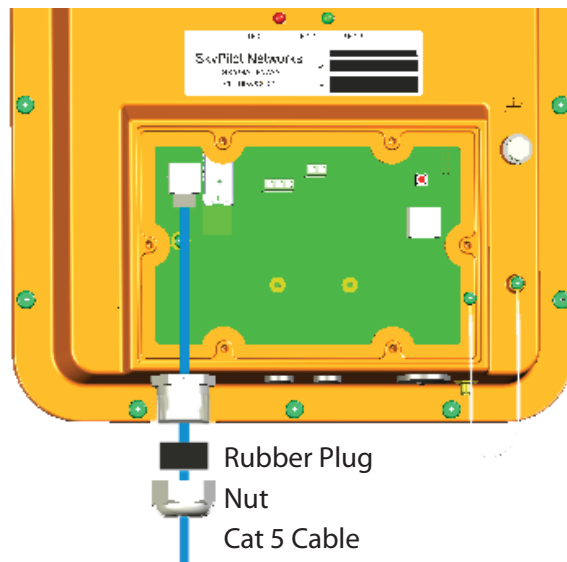

GPS Antenna

- 1 Attach the GPS antenna bracket to the top of the unit, on the back, using two small Phillips screws. This is shown in Figure 4-3.
- 2 Connect the GPS antenna cable to the SMA connector on the unit bottom.
- 3 The GPS antenna is magnetic, and will stick to the mounting bracket.
- 4 Temporarily place the GPS antenna where it can pick up a GPS signal. You can use a hand-held GPS device, such as an iPhone, to determine if there is adequate signal strength in your location.

Figure 4-3. GPS bracket

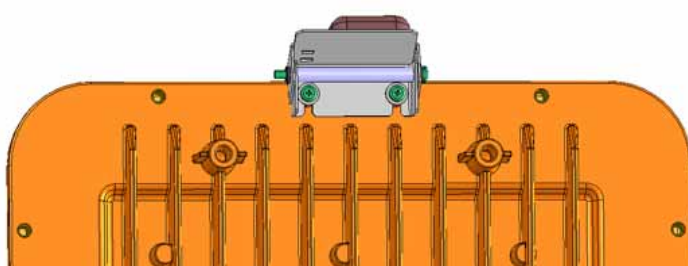

Powering Up

- 1 Connect a power cord to the power supply, and plug it in.
- 2 Connect the Ethernet cable from the SkyPilot Gateway Pro to the port labeled "Output" on the power supply.
- 3 Connect an Ethernet cable from the port labeled "Input" to your network.

Monitoring the Power-On Sequence

When the SkyPilot Gateway Pro is powered up, it starts a power-on sequence. You can monitor it by observing the pair of LED lights on the back of the device. The power-on sequence may take up to 15 minutes, depending on how quickly the device can acquire a GPS signal.

NOTE The SkyPilot Gateway Pro must have access to a GPS signal to complete its power-on sequence and start making wireless network connections. Depending on your SkyPilot network configuration, the device may be unable to connect to the network until the device has been configured.

Table 4-1 provides detailed descriptions of device states indicated by the LEDs.

Table 4-1. SkyPilot Gateway Pro LED Status Lights

Device state	LED 1 (left)	LED 2 (right)
Startup in progress	Slow staggered blinking of both LEDs	
Startup failure	Off	On
Initializing image, acquiring GPS signal	Blinks 4 times; repeats	Blinks 4 times; repeats
Initialization failure	Fast, synchronized blinking of both LEDs	
Successful initialization, but authorization failure	Green	Off
Successful initialization, but no links found	Green	???
Connected	Green	Blue

Configuring the SkyPilot Gateway Pro

To operate on the wireless mesh network, the SkyPilot Gateway Pro requires a network configuration. A SkyPilot Gateway Pro will not transmit a wireless signal until it is configured, and it will not be able to connect to other network devices without a configuration.

SkyPilot offers two modes for provisioning devices with a configuration:

- **Automatic**—Requires the use of SkyPilot EMS software to create configurations that an unattended central server can distribute to devices on the wireless mesh network. Although automatic provisioning requires more initial setup time than manual provisioning, it greatly simplifies the administration of a growing network.

Detailed procedures for using EMS software are provided in *SkyPilot Network Administration*, available from the SkyPilot website at www.skypilot.com/support/.

- **Manual**—Manual provisioning permits the configuration of only a single device at a time, creating the minimum settings required for a wireless link and storing them in the device's flash (nonvolatile) memory. Manual provisioning is a logical choice if you're installing a test network or rolling out a small-scale installation that isn't expected to expand.

For more information about provisioning modes, refer to *Getting Started with the SkyPilot Network*, available from the SkyPilot website at www.skypilot.com/support/.

Accessing the Command-Line Interface

SkyPilot devices include a command-line interface which you can use for manual provisioning and troubleshooting.

You can connect to a device and access its command-line interface through Telnet over an Ethernet connection or via a terminal session from a console connected to the device's RJ-45 serial port. The default IP address is 192.168.0.2

After logging in (user: admin; password: public), you can enter commands at the command prompt.

For detailed access instructions for the command-line interface, refer to the *SkyPilot Command-Line Interface Reference*.

Manually Provisioning Devices

Manual provisioning stores settings in the device's flash memory, where they remain available for recall when the device starts up.

NOTE If you're installing a device in a location that poses difficulties, consider delaying the final mounting until you can confirm that provisioning was successful.

Table 4-2 summarizes the steps required to manually provision a device.

Table 4-2. Manually Provisioning a Device (Page 1 of 2)

Step		Refer to
1	Decide whether to provision the device using the command-line interface or the Web interface. (For DualBand/ access points, you must use the Web interface.)	"Choosing a Manual Provisioning Method" in <i>SkyPilot Network Administration</i>
2	Prepare the device for installation by installing the necessary cabling, attaching antennas (for DualBands), and readying the device for service. Do <i>not</i> install the device yet.	The appropriate installation manual: <ul style="list-style-type: none">• <i>SkyGateway/SkyExtender Installation and Setup</i>• <i>SkyConnector Indoor Installation</i>• <i>SkyConnector Outdoor Installation</i>
3	Power on the device.	

Table 4-2. Manually Provisioning a Device (Page 2 of 2)

Step	Refer to
<p>4 Connect a computer to the device and access the command-line interface or the Web interface.</p> <p>(For DualBands, this step refers to the SkyPilot Extender portion of the device.)</p>	<p>The appropriate interface reference manual:</p> <ul style="list-style-type: none"> ● <i>SkyPilot Command-Line Interface Reference</i> ● <i>SkyPilot Web Interface Reference</i>
<p>5 Provision the device.</p> <p>(For DualBands, this step refers to the SkyPilot Extender portion of the device.)</p>	<p>Either of the following provisioning tool references, making sure to set at least the minimum provisioning parameters (refer to “Required Provisioning Parameters” and in <i>SkyPilot Network Administration</i>):</p> <ul style="list-style-type: none"> ● <i>SkyPilot Command-Line Interface Reference</i> ● <i>SkyPilot Web Interface Reference</i>
<p>6 For DualBands, reboot the device, connect a computer to the device’s 2.4 GHz access point, and provision the access point.</p>	<p><i>SkyPilot Web Interface Reference</i></p>
<p>7 Power off the device.</p>	
<p>8 Complete the installation.</p>	<p>The appropriate installation manual:</p> <ul style="list-style-type: none"> ● <i>SkyGateway/SkyExtender Installation and Setup</i> ● <i>SkyConnector Indoor Installation</i> ● <i>SkyConnector Outdoor Installation</i>
<p>9 Power on the device.</p>	

Automatically Provisioning All Network Devices

Table 4-3 summarizes the steps required to automatically provision all devices on a network. Although it's possible to provision SkyPilot devices in any order, by following this sequence you can ensure that devices are able to form links as soon as they come online.

Table 4-3. Automatically Provisioning All Network Devices (Page 1 of 2)

Step		Refer to
1	For new SkyPilot network deployments, custom-install the operating system software on the SkyPilot EMS server.	The appropriate installation manual: <ul style="list-style-type: none">• <i>SkyPilot OS Installation: Red Hat Linux 9.0</i>• <i>SkyPilot OS Installation: Fedora Core 2 and 4</i>• <i>SkyPilot OS Installation: Red Hat Enterprise Linux ES 3 and 4</i>
2	For new SkyPilot network deployments, install the server component of SkyPilot EMS, and then install the client component of SkyPilot EMS on any appropriate computer.	<i>SkyPilot EMS Installation</i>
3	For new SkyPilot Gateway Pros, set up the DHCP server and, if the provisioning server is behind a firewall, specify ports for data traffic between the server and SkyPilot devices.	"Adding Devices to the DHCP Configuration File" in <i>SkyPilot Network Administration</i>
4	Provision the SkyPilot Gateway Pro(s).	The following automatic provisioning topics in <i>SkyPilot Network Administration</i> : <ul style="list-style-type: none">• "Provisioning a Device"• "Starting SkyProvision"• "SkyProvision Display Pane"• "Searching for Configured Devices"

Table 4-3. Automatically Provisioning All Network Devices (Page 2 of 2)

Step	Refer to
5 For new SkyPilot Gateway Pros, complete the installation and power it on.	<i>SkyGateway/SkyExtender Installation and Setup</i>
6 (Optional) Log in to the SkyPilot Gateway Pro and configure the management VLAN.	<i>"The SkyPilot EMS Interface" in SkyPilot Network Administration</i>
7 Provision the SkyPilot Extender(s).	The following automatic provisioning topics in <i>SkyPilot Network Administration</i> : <ul style="list-style-type: none"> • "Provisioning a Device" • "Starting SkyProvision" • "SkyProvision Display Pane" • "Searching for Configured Devices"
8 For DualBands, provision the access point(s).	For information about access point settings, refer to <i>SkyPilot Network Administration</i> . For configuration procedures, refer to the <i>SkyPilot Web Interface Reference</i>
9 For new SkyPilot Extenders, install the device and power it on.	<i>SkyGateway/SkyExtender Installation and Setup</i>
10 Provision the SkyPilot Connector(s).	<ul style="list-style-type: none"> • Same as for step 7.
11 For new SkyPilot Connectors, install the device and power it on.	The appropriate installation manual: <ul style="list-style-type: none"> • <i>SkyConnector Indoor Installation</i> • <i>SkyConnector Outdoor Installation</i>

Configuring Adjacent SkyPilot Gateway Pros

is quite tricky...

Installing the SkyPilot Gateway Pro

This chapter provides instructions for configuring the SkyPilot Gateway Pro and then performing the physical installation.

Install Devices

You can ensure optimum operation—and reduce administrative overhead—by installing your network devices in this order:

- SkyPilot Network Management System
- SkyPilot Gateway Pro
- SkyPilot Extenders (optional)
- SkyPilot Connectors.

You install the SkyPilot Gateway Pro first because, as the base station of the SkyPilot wireless network, it must be present in order for other devices to establish network links. When provisioned and powered on, the SkyPilot Gateway Pro immediately starts transmitting hello beacons that SkyPilot Extenders and Sky Connectors use to form links.

After installing the SkyPilot Gateway Pro, you add SkyPilot Extenders (if required) and then SkyPilot Connectors. Upon powering on, each device responds to the base station's hello beacon and starts forming links with the SkyPilot Gateway Pro. Each device attempts to establish as many links as possible before choosing an optimum path.

After establishing network links, SkyPilot Extenders on your network also begin transmitting hello beacons, extending the range of beacons available to other devices. (SkyPilot Connectors do not transmit hello beacons.)

Mounting

The SkyPilot Gateway Pro uses two hinged mounting brackets to allow it to be tilted up or down slightly, as needed.

Figure 5-1. Mounted SkyPilot Gateway Pro



To mount the SkyPilot Gateway Pro:

IMPORTANT It is the installer's responsibility to verify that the support pole and its installation method are of sufficient strength to withstand onsite weather conditions. (The supplied mounting bracket and screws are certified to withstand a 150 mph wind force.)

- 1 Attach one of the pole-clamp assemblies to the pole at the height you want for the top of the unit. Make sure the threaded holes are facing up. Use the long bolts in the kit.

Figure 5-2. Pole Clamps: Top View at Left; Bottom View at Right

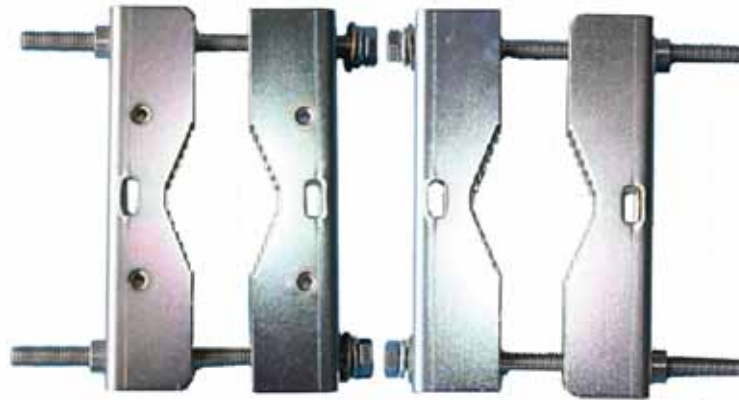

- 2 Attach the second pole-clamp assembly to the pole, about nine inches lower than the first. Again, make sure the threaded holes are facing up.

Figure 5-3. Pole Clamps Attached to Pole



- 3 Attach the hinged brackets to the SkyPilot Gateway Pro using the supplied 1/4-28 UNC bolts. These have hex heads. Do not use the Phillips-head screws. Use thread-locking compound.

The brackets should be attached so that the body of the bracket is below the mounting holes. This, in turn, will orient the hook-tab, which is at the other end of the bracket, down.

IMPORTANT The double-hinged mounting bracket and the single-hinged bracket, together, allow you to tilt the unit. If you need to tilt it down, use the double-hinged bracket on top. If you need to tilt it up, use the double-hinged bracket on the bottom.

IMPORTANT The holes in the unit are fine-thread. DO NOT use 1/4-20 UNC (coarse thread) hardware in these holes.

IMPORTANT The SkyPilot Gateway Pro case is aluminum. Do not over-torque the mounting bolts.

NOTE Your SkyPilot Gateway Pro can be wall-mounted. You will need lag bolts or other fasteners suitable for attaching to the wall. Use them to attach one-half of the pole clamp to the wall, then hang the SkyPilot Gateway Pro as described below.

Figure 5-4. SkyPilot Gateway Pro with Mounting Brackets Attached

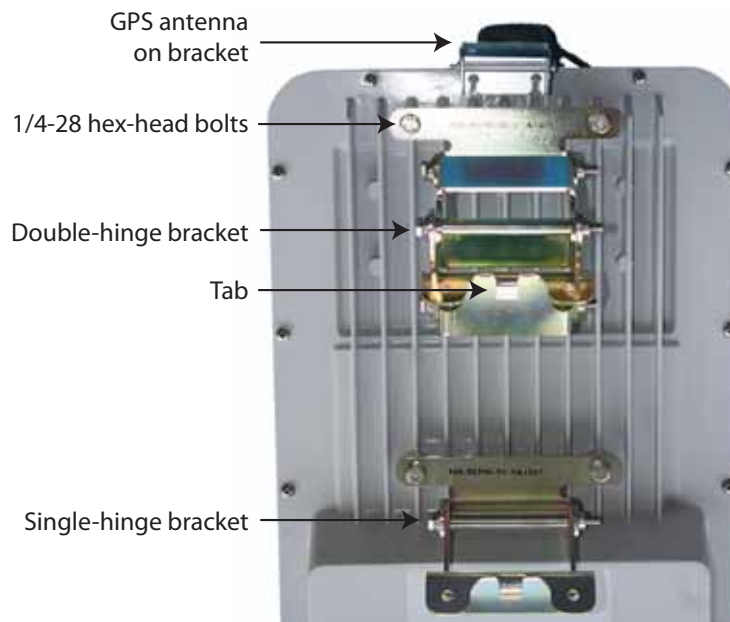

- 4 The SkyPilot Gateway Pro can now be hung from the pole clamps. The tabs fit into recesses in the pole clamps. Use the 1/4-20 Phillips screws to secure the brackets to the clamps.

Figure 5-5. SkyPilot Pro-Top View - Showing Tabs & Screws

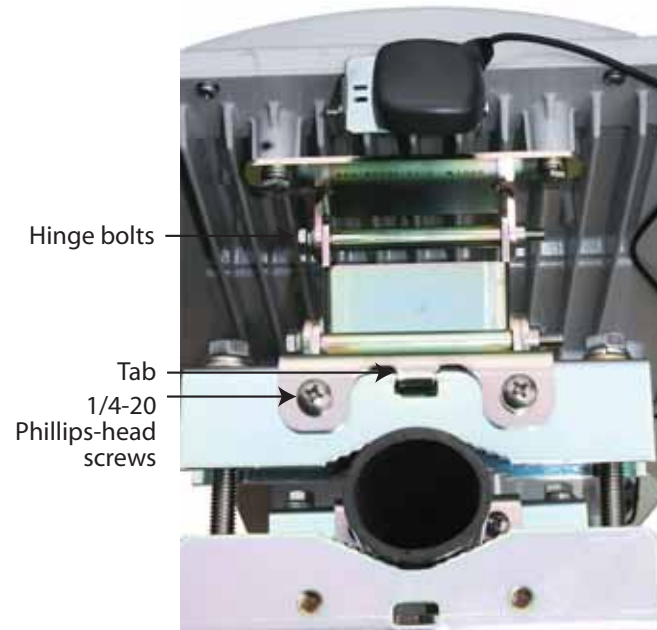

- 5 Adjust the angle of the unit, and then tighten the hinge bolts.

Verifying Connectivity

After provisioning and installing your SkyPilot devices, you should perform the procedures in the following sections to confirm that the devices are properly connected to the network.

Confirming SkyPilot Gateway Pro Connectivity

There are two ways to confirm SkyPilot Gateway Pro connectivity:

- Check the LED status lights on the SkyPilot Gateway Pro to verify that the device is fully online.

See Table 6-1 for a summary of what the LED status lights mean. For a detailed description of the status lights, refer to *SkyGateway/SkyExtender Installation and Setup*.

Table 6-1. SkyPilot Gateway Pro LED status lights

Device state	Link LED	Activity LED
Startup in progress	Slow staggered blinking of both LEDs	
Startup failure	Off	On
Initializing image (and acquiring GPS signal)	Blinks 4 times; repeats cycle	Blinks 4 times; repeats cycle
Initialization failure	Fast, synchronized blinking of both LEDs	
Successful initialization, but authorization failure	On	Off
Connected	On	On

- From the command line, use the **ping** command to verify that you can reach the device's default gateway

For example:

```
> ping 192.168.5.1
```

```
PING 192.168.5.1: 56 data bytes  
64 bytes from 192.168.5.1: icmp_seq=0. time=11. ms  
64 bytes from 192.168.5.1: icmp_seq=1. time=12. ms  
64 bytes from 192.168.5.1: icmp_seq=2. time=12. ms  
----192.168.5.1 PING Statistics----  
3 packets transmitted, 3 packets received, 0% packet loss  
round-trip (ms) min/avg/max = 0/16/32
```

Confirming SkyPilot Extender and SkyPilot Connector Connectivity

There are four ways to confirm SkyPilot Extender and SkyPilot Connector connectivity. You can use any method at any time.

- Check the LED status lights on the device to verify that the device is fully online.

For a summary of what the LED status lights mean, see Table 6-2 (for SkyPilot Extenders) or Table 6-3 (for SkyPilot Connectors). For a detailed description of the status lights, refer to the installation guide for the device.

Table 6-2. SkyPilot Extender/DualBand LED status lights

Device state	Link LED	Activity LED
Startup in progress	Slow staggered blinking of both LEDs	
Startup failure	Off	On
Initializing image (and acquiring GPS signal)	Blinks 4 times; repeats cycle	Blinks 4 times; repeats cycle
Initialization failure	Fast, synchronized blinking of both LEDs	
Successful initialization, but can't locate hello	On	Off
Successful initialization; heard hello on antennas with power levels in the proper RSSI range	Off	Blink (modulation rate-based)
Successful initialization; link is not optimized, or is in pre-authorization	Slow blink	Blink (modulation rate-based)
Successful initialization; link is in standby state on antenna and modulation rate	Fast blink	Blink (modulation rate-based)
Connected	On	On

Table 6-3. SkyPilot Connector LED status lights

LED	LED state	Device state
Lan Link	Steady illumination	SkyPilot Connector is connected to another device via its Ethernet port
LAN Act	Blinking	Device is transmitting or receiving data via its Ethernet port
WAN Link	Blinking (fast blink when device is in standby mode)	Device is attempting to establish an authorized connection on the wireless network
	Steady illumination	Device is connected to the wireless network
WAN Act	None	Device cannot detect a wireless network
	Blinking	Device is within the coverage area of a wireless network. Blink indicates signal strength: <ul style="list-style-type: none"> ● Fast (8x per second): excellent ● Medium (4x per second): good ● Slow (<1x per second): poor

- From the command line, use the **show link** command to confirm that an active link exists.

The device is online if the output displays an **act path** (active path) link state.

For example:

```
Node Id      LType NType State  RSSI LTxMod RTxMod LAnt RAnt
-----
00:0a:db:00:00:43 data  ext  act path 39 48 36 2 4
```

- Use the **traceroute** command to confirm that you can send and receive data across the wireless network.

The **traceroute** command performs a SkyPilot protocol trace that shows the path to the SkyPilot Gateway Pro. Entering the **traceroute** command

without arguments returns a path that the device identifies as its exit from the network.

For example:

```
> traceroute

traceroute to 00:0a:db:00:00:a6
>>  1 (48) --> 00:00:43 --> (36)
2 (36) --> 00:00:a6 --> (36)
```

- Use the **ping** command to verify that you can reach the device's default gateway.

For example:

```
> ping 192.168.5.1

PING 192.168.5.1: 56 data bytes
64 bytes from 192.168.5.1: icmp_seq=0. time=11. ms
64 bytes from 192.168.5.1: icmp_seq=1. time=12. ms
64 bytes from 192.168.5.1: icmp_seq=2. time=12. ms ----
192.168.5.1 PING
Statistics---- 3 packets transmitted, 3 packets received, 0%
packet loss round-trip (ms) min/avg/max = 0/16/32
```

Confirming SkyPilot Extender DualBand Access Point Connectivity

There are four ways to confirm SkyPilot Extender DualBand access point connectivity:

- Use the **ping** command to verify that the access point is up and running—for example, **ping 192.168.0.3**.
- For SkyPilot firmware versions 1.2p3 and later, use the **show version ap** command to verify the firmware version and, indirectly, that proper heartbeats are being sent from the PePLink Linux access point.
- From the command line, enable debugging (using the **debug on** command) and use the **set log apwatchdog 3** command to display successful or failed heartbeat updates, reboot notices, factory resets, and so on.
- Using an 802.11b/g wireless card, connect to the default SSID, a string representation of the SkyPilot Extender's MAC address with the WPA passphrase **publicpublic**.

Once connected, use the **ping** command to verify that you can reach both the SkyPilot Extender and the access point. For example:

```
> ping 192.168.0.3
```

```
PING 192.168.5.1: 56 data bytes
64 bytes from 192.168.0.3: icmp_seq=0. time=11. ms
64 bytes from 192.168.0.3: icmp_seq=1. time=12. ms
64 bytes from 192.168.0.3: icmp_seq=2. time=12. ms ----
192.168.5.1 PING
Statistics---- 3 packets transmitted, 3 packets received, 0%
packet loss round-trip (ms) min/avg/max = 0/16/32
```

```
> ping 192.168.0.2
```

```
PING 192.168.5.1: 56 data bytes
64 bytes from 192.168.0.2: icmp_seq=0. time=11. ms
64 bytes from 192.168.0.2: icmp_seq=1. time=12. ms
64 bytes from 192.168.0.2: icmp_seq=2. time=12. ms ----
192.168.5.1 PING
Statistics---- 3 packets transmitted, 3 packets received, 0%
packet loss round-trip (ms) min/avg/max = 0/16/32
```

Troubleshooting

After making an Ethernet or serial connection to the SkyPilot Gateway Pro, you can manage and troubleshoot the device using a wide range of commands available through the command-line interface.

For detailed troubleshooting procedures, refer to the “Troubleshooting” section in *SkyPilot Network Administration*. There you’ll find troubleshooting procedures for:

- Power-on problems
- Ethernet connectivity problems
- IP connectivity problems
- SkyPilot Gateway Pro Transmission problems
- Link failure problems

Grounding Guidelines

This appendix provides some guidelines for properly grounding the SkyPilot Gateway Pro.

Proper grounding protects both your SkyPilot device and equipment connected to it. For the surge protection circuitry built into the SkyPilot equipment to be effective, proper grounding of the unit is necessary. This is especially true if you're installing devices on tall structures, or in areas subject to lightning.

NOTE The techniques described in this appendix are intended as general guidelines only and do not constitute a comprehensive guide covering all installation scenarios. For maximum protection, contact a qualified installation specialist who is familiar with your operating environments. If lightning is a threat in your area, consider a consultation with a lightning and transient protection specialist.

General Grounding Strategy

To ensure optimum reliability, properly ground the metal base of the SkyPilot device. The most efficient way to ground the device is to use an 8 GA or larger wire to connect it to a ground point on the mounting structure or tower.

The three most common ground points are:

- A cold-water pipe. Make sure it is well-connected to earth.
- The primary grounding point of the AC electrical system of the building.
- A 10-foot or longer copper-clad ground rod driven into the earth. For a tower with multiple legs, you need one ground rod per leg and a ground wire loop connecting each of the rods; see Figure 12.

Figure 12. Ground wire loop

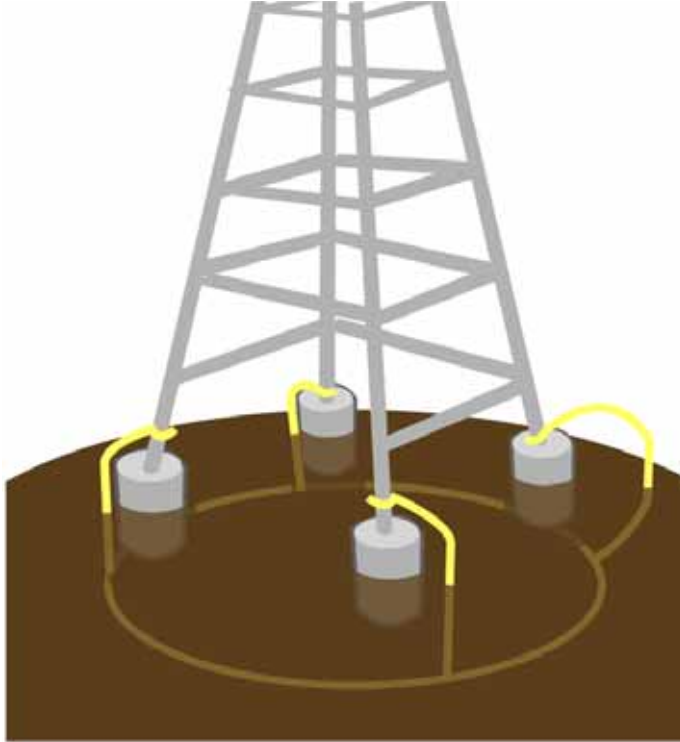

Making Connections “Gas-Tight”

Regardless of the grounding point you use, make sure the connections are “gas-tight”—capable of retaining low resistance and integrity over time and with exposure to the elements.

Use of an antioxidant compound and proper sealing is essential. For protection against corrosion, wrap all connections with Scotch® 130C tape.

Checking Cold-Water Pipe Integrity

If you’re using a cold-water pipe for grounding, verify the integrity of the ground. In some cases, sections of metal cold-water pipes may have been repaired or extended with PVC material. PVC material or a dielectric union will render a cold-water pipe ground unacceptable for grounding.

Measuring Resistance

Verify that there is no more than 5 ohms of resistance between any two ground points in the entire system. Also make sure that all ground points on a structure are tied together. For example, if you use a ground rod and a cold-water pipe as grounding points at different locations on the same structure, you must tie them together.

Adding Surge Protection

If you're installing a SkyPilot device in an area that's subject to lightning storms, SkyPilot recommends installing a surge protection device (SPD) at both ends of the Ethernet cable—one at the SkyPilot device and one at the point of entry to a building or enclosure.

SkyPilot offers SPDs with bracket and cabling designed for use with SkyPilot equipment. For more information, visit SkyPilot customer support at www.skypilot.com/support/ to view accessory guides for SkyPilot-branded surge protection solution. (You may also purchase SPDs from third-party vendors.)

Grounding Checklist

When grounding a SkyPilot device, use the following checklist to confirm that your installation is adequately protected from power surges and lightning.

- Connect a ground wire from the SkyPilot device to a ground system on the building or tower.
- Use shielded CAT5 cabling and connect the drain wire of the shield to ground at the SkyPilot device. (Leave the other end of the drain wire unconnected.)
- Use the proper size down lead to connect a SkyPilot device on a roof or tower to the ground system of indoor equipment.
- Verify that all points of the ground system are tied together with less than 5 ohms resistance between any two points.

- Run the CAT5 cable inside the tower structure, tying the cable to the tower leg at every 4 feet of length. For increased protection, run the CAT5 cable through metallic conduit installed on the tower.
- Bleed off any static charge by installing a streamer-delaying, static-dissipation array above the SkyPilot device.
- Install all lightning and surge protection devices in accordance with UL 96A installation requirements for lightning protection systems and the NFPA 780 standard for lightning protection.

Specifications

This appendix provides technical specifications for the SkyPilot Gateway Pro (Table C-1),

Table C-1. SkyPilot Gateway Pro Specifications (Page 1 of 3)

Wireless Specifications

Frequency bands	5.150–5.450 GHz 5.450–5.725 GHz 5.725–5.850 GHz
EIRP	44.5 dBm/28.2W peak, 36 dBm/4W average, 33 dBm/2W average, 30 dBm/1W average, or 36 dBm/4W peak (EIRP selected for country-specific regulations)
Media access	Time Division Duplex (TDD)
Modulation technique	OFDM with adaptive modulation
Modulation rates	6–54 Mbps
Throughput	UDP: Up to 20 Mbps TCP: Up to 10.5 Mbps
Latency	10–12 ms round trip per hop
Antennas	Electronically-steered antenna, 180-degree coverage
Channel width	20 MHz
Channel resolution	5 MHz frequency control
Receive sensitivity	-90 dBm at 6 Mbps modulation
Connectivity	SkyPilot Gateway Pro connects with: SkyPilot Extenders, SkyPilot Extender DualBands SkyPilot Connectors.
Authentication	MD5-based certificates
Encryption	128-bit AES on all wireless links

Table C-1. SkyPilot Gateway Pro Specifications (Page 2 of 3)

Product Specifications

Connectors	RJ-45: Ethernet connection (10/100Base-T) and power (Power over Ethernet) RJ-45: RS-232 serial for local management
Mounting	Tower, utility pole, building, or other infrastructure, outside pole diameter up to 2.5". Wall mount possible.
Range	Up to 10 miles (16 km)
LEDs	Wireless activity, wireless link
Dimensions	17" (43 cm) H x 11.6" (29.5 cm) wide x 5.5" (14 cm) thick
Weight	11 pounds (5 kg), basic unit 17 pounds (7.7 kg) with standard mounting hardware
Operating temperature	-40° to 131° F (-40° to 55° C)
Wind loading	Up to 150 mph (240 km/h)
Enclosure/humidity	NEMA-4X
External PoE PSE Power	110–230 VAC, 50–60 Hz input, 16 watts maximum
Certifications	FCC Part 15, FCC 47 CFR Part 15, Class B USA; compliance with UL safety standards, CE, C-Tick, IC RSS210 Issue 5
EMI and susceptibility	FCC Part 15.107 and 15.109
Warranty	One-year limited warranty on hardware and software

Security

Authentication	MD5-based certificates
Encryption	AES
Filtering	Based on protocol type, IP port ID, and configurable IP address list

Network management

Command-line interface	Console via RS-232 serial port or SSH
NMS Integration	SNMP v2c

Table C-1. SkyPilot Gateway Pro Specifications (Page 3 of 3)

GUI configuration	SkyProvision™ software and Web interface
GUI EMS	SkyPilot EMS™ software
IP address	DHCP or static. 192.168.02. default
Firmware	Multiple versions of firmware stored in nonvolatile memory; updated via FTP
Configuration file	XML over HTTP

QoS (Quality of Service)

Prioritization	802.1p-based; based on protocol type, IP address, port ID, and configurable IP address list
Traffic shaping	Per-device rate limits upstream and downstream

Monitoring and MIB support

Supported MIBs	MIB-II (RFC 1213); EtherLike (RFC 2665); Bridge (RFC 1493); SkyPilot private MIB
Local management	RS-232 Serial Console Port
Remote management	Command-line interface via Telnet, SNMP 2c, Web interface

Topology

Configurations	Mesh, point-to-multipoint, point-to-point
----------------	---

Pinouts

This appendix provides pinouts for connectors and adapters to connect to the Ethernet interface port labeled “CPE” on the SkyPilot Gateway Pro power supply and the device’s serial interface.

RJ-45 Pins

Table D-1 lists the RJ-45 pin assignments.

Table D-1. RJ-45 Pin Assignments

Pin	Assignment
1	Ethernet
2	Ethernet
3	Ethernet
4	Power
5	Power
6	Ethernet
7	Power
8	Power

DB-9 Adapter

Table D-2 lists connecting pins between the SkyPilot Gateway Pro “CPE” port (RJ-45 connector) and a standard computer DB-9 serial port.

Table D-2. RJ-45 Pin Assignments

SkyPilot Gateway/Extender “CPE” port		Computer serial port	
Signal	Pin	Pin	Signal
TxD	3	2	RxD
GND	4	5	GND
RxD	6	3	TxD

The following figures show the connection between the SkyPilot Gateway Pro “CPE” port and a standard computer DB-9 serial port, the DB-9 pinouts, and the cable-pin correspondence.

Figure D-1. RJ-45 to DB-9 physical connectors

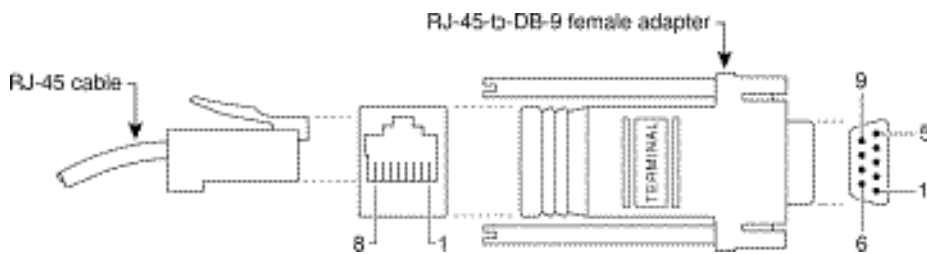
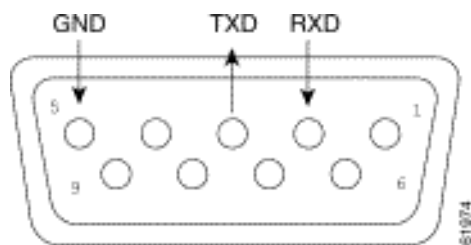
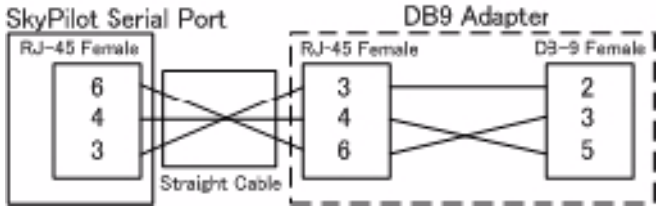

Figure D-2. DB-9 pins



If you're using a straight through cable, the connection can be visualized as shown in Figure D-3.

Figure D-3. Straight through cabling



Although there is no official standard, the connector wire colors typically are as described in Table D-3.

Table D-3. Typical RJ-45 DB-9 Wire Colors

Color	RJ-45 pin	DB-9 pin
Black	3	2
Yellow	6	3
Red	4	5

Regulatory information

Federal Communications Commission (FCC) compliance notices

This section includes the following FCC statements for the SP-5200-A and related SkyPilot by Trilliant products:

- FCC ID: RV7-GWPRO
- Class A Interference Statement
- RF Radiation Exposure and Hazard Warning
- Non-Modification Statement
- Deployment Statement

Class A Interference Statement

This equipment has been tested and found to comply with the limits for a Class A digital device, pursuant to Part 15 of the FCC Rules. These limits are designed to provide reasonable protection against harmful interference in a commercial installation. This equipment generates, uses, and can radiate radio frequency energy and, if not installed and used in accordance with the instructions, may cause harmful interference to radio communications. However, there is no guarantee that interference will not occur in a particular installation. If this equipment does cause harmful interference to radio or television reception, which can be determined by turning the equipment off and on, the user is encouraged to try to correct the interference by one or more of the following measures:

- Reorient or relocate the receiving antenna.
- Increase the separation between the equipment and receiver.
- Connect the equipment into an outlet on a circuit different from that to which the receiver is connected.
- Consult the dealer or an experienced radio/TV technician for help.

FCC Caution:

This device complies with Part 15 of the FCC Rules. Operation is subject to the following two conditions: (1) This device may not cause harmful interference, and (2) this device must accept any interference received, including interference that may cause undesired operation.

RF Radiation Exposure & Hazard Statement

To ensure compliance with FCC RF exposure requirements, this device must be installed in a location such that the antenna of the device will be greater than 20 cm (8 in.) away from all persons. Using higher gain antennas and types of antennas not covered under the FCC certification of this product is not allowed. Installers of the radio and end users of the product must adhere to the installation instructions provided in this manual. This transmitter must not be co-located or operated in conjunction with any other antenna or transmitter.

Non-Modification Statement

Use only the supplied internal antenna. Unauthorized antennas, modifications, or attachments could damage the SP-5200-A and related SkyPilot by Trilliant products and violate FCC regulations. Any changes or modifications not expressly approved by the party responsible for compliance could void the user's authority to operate this equipment.

Deployment Statement

This product is certified for indoor deployment only in the 5150 – 5250 MHz band. Do not install or use this product outdoors in that frequency band in the United States.

Dynamic Frequency Selection (DFS) in the 5.0 GHz UNII bands

The SP-5200-A has been prohibited from operating in the 5600 to 5650 MHz frequency band for the US and Canada in order to comply with the DFS requirements as outlined in the FCC Part 15, Subpart E rules.

Canadian IC Statements

IC: 6028A-GWPRO

This device complies with ICES-003 and RSS-210 of Industry Canada.

Operation is subject to the following two conditions:

1. This device may not cause interference, and
2. This device must accept any interference, including interference that may cause undesired operation of the device.

Ce dispositif est conforme aux normes NMB003 et CNR-210 d'Industrie Canada.

1. L'utilisation de ce dispositif est autorisée seulement aux conditions suivantes :
2. il ne doit pas produire de brouillage et l'utilisateur du dispositif doit être prêt à accepter tout brouillage radioélectrique reçu, même si ce brouillage est susceptible de compromettre le fonctionnement du dispositif.

RF Radiation Exposure & Hazard Statement

To ensure compliance with RSS-102 RF exposure requirements, this device must be installed in a location such that the antenna of the device will be greater than 20 cm (8 in.) away from all persons. Using higher gain antennas and types of antennas not covered under the IC certification of this product is not allowed. Installers of the radio and end users of the product must adhere to the installation instructions provided in this manual. This transmitter must not be co-located or operated in conjunction with any other antenna or transmitter.

Exposition aux radiations RF & Mention de danger

Pour assurer la conformité avec les exigences RSS-102 d'exposition aux RF (Radio Fréquences), cet appareil doit être installé dans un endroit où l'antenne de l'appareil sera située à une distance de plus de 20 cm (8 po) de toutes personnes. L'utilisation d'antennes à gain plus élevé et les types d'antennes qui ne sont pas couverts en vertu de la certification IC de ce produit n'est pas autorisée. Les installateurs de la radio et les utilisateurs du produit final doivent se conformer aux instructions d'installation fournies dans ce manuel. Cet émetteur ne doit pas être co-implanté ou exploité en conjonction avec toute autre antenne ou transmetteur.

Deployment Statement

This product is certified for indoor deployment only in the 5150 – 5250 MHz band. Do not install or use this product outdoors in that frequency band in Canada.

Déclaration de déploiement

Ce produit est certifié pour le déploiement à l'intérieur tout en rencontrant les limites de cette bande de fréquences: 5150 - 5250 MHz. Ne pas installer ou utiliser ce produit à l'extérieur au Canada, si cette bande de fréquences ne peut être rencontrée.

SAFETY INFORMATION

**Hazard Warning!**

High Voltage. This situation or condition can cause injury due to electric shock.

Warnung!

Lesen und befolgen Sie die Warnhinweise und Anweisungen, die auf dem Produkt angebracht oder in der Dokumentation enthalten sind.

**Warning!**

Read and follow all warning notices and instructions marked on the product or included in the documentation.

Warnung!

Lesen und befolgen Sie die Warnhinweise und Anweisungen, die auf dem Produkt angebracht oder in der Dokumentation enthalten sind.

**Warning!**

Only use attachments and accessories specified and/or sold by the manufacturer.

Warnung!

Verwenden Sie nur Zusatzgeräte und Zubehör angegeben und / oder verkauft wurde durch den Hersteller.

**Warning!**

Refer all servicing to qualified service personnel. Servicing is required when the device has been damaged in any way, such as power-supply cord or plug is damaged, liquid has been spilled or objects have fallen into the device, the device has been exposed to rain or moisture, does not operate normally, or has been dropped.

Warnung!

Das Gerät sollte nur von qualifizierten Fachkräften gewartet werden. Eine Wartung ist fällig, wenn das Gerät in irgendeiner Weise beschädigt wurde, wie bei beschädigtem Netzkabel oder Netzstecker, falls Flüssigkeiten oder Objekte in das Gerät gelangen, das Gerät Regen oder Feuchtigkeit ausgesetzt wurde, nicht ordnungsgemäß funktioniert oder fallen gelassen wurde.

**Warning!**

Do not open the chassis. There are no user-serviceable parts inside. Opening the chassis will void the warranty unless performed by an Trilliant service center or licensed facility.

Warnung!

Öffnen Sie das Gehäuse nicht. Keine der Geräteteile können vom Benutzer gewartet werden. Durch das Öffnen des Gehäuses wird die Garantie hinfällig, es sei denn, solche Wartungsarbeiten werden in einem Trilliant-Service-Center oder einem lizenzierten Betrieb vorgenommen.