

Hardware User Guide Overview for *Open Smart Device Interface (OSDI) SecureMesh™* Module

Models:

- OSDI-4000-1D
- OSDI-4000-1A

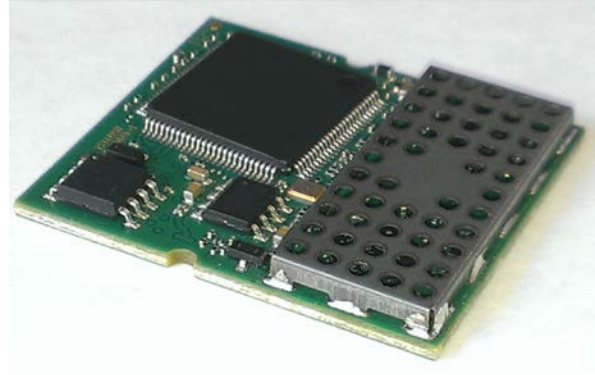

PRINTED VERSIONS OF THIS DOCUMENT ARE UNCONTROLLED

Distributed under legal commercial agreement

DOCUMENT RELEASE/APPROVALS

document #	DT-0237A		
current revision	1.0		
approvals	name	title	date

LEGAL NOTICES

THIS DOCUMENT CONTAINS SENSITIVE PROPRIETARY AND CONFIDENTIAL INFORMATION OWNED BY TRILLIANT NETWORKS. THIS DOCUMENT HAS BEEN PROVIDED TO YOUR COMPANY THROUGH A PREVIOUSLY EXECUTED OSDI MODULE DESIGN LICENSE AGREEMENT AND MAY NOT BE DISTRIBUTED TO ANY OTHER 3RD PARTY, IN ANY FORM OR PORTION, WITHOUT TRILLIANT'S EXPRESSED WRITTEN PERMISSION.

LICENSEE ACKNOWLEDGES THAT THE OSDI MODULE DOCUMENTATION PACKAGE AND TOOLS ARE LICENSED TO IT ON AN "AS IS" BASIS. TRILLIANT MAKES NO OTHER REPRESENTATIONS AND EXTENDS NO OTHER WARRANTIES OR CONDITIONS OF ANY KIND, EXPRESS, IMPLIED OR STATUTORY INCLUDING WARRANTIES OF NONINFRINGEMENT, MERCHANTABILITY AND FITNESS FOR A PARTICULAR USE. EXCEPT AS OTHERWISE EXPRESSLY SET FORTH IN THIS LICENSE, TRILLIANT ASSUMES NO RESPONSIBILITIES OR LIABILITIES WHATSOEVER WITH RESPECT TO USE OR SALE BY EITHER LICENSEE OR ITS VENDEES OR TRANSFEREES OF COMBINED PRODUCTS.

THE INFORMATION CONTAINED IN THIS DOCUMENT IS SUBJECT TO CHANGE WITHOUT NOTICE. TRILLIANT RESERVES THE RIGHT TO CHANGE THE PRODUCT SPECIFICATIONS WITHOUT CONSEQUENCE OF LIABILITY.



Trilliant Incorporated
1100 Island Drive, Redwood
City, CA 94065 USA
+1.650.204.5050
www.trilliantinc.com

Trilliant™, CellReader®, CellGateway™, SecureMesh™, SerViewCom®, UnitySuite™, SkyPilot®, SyncMesh™, the Trilliant logo, and the SkyPilot logo are trademarks of Trilliant Incorporated and/or its subsidiaries. All other trademarks are the property of their respective owners.

Copyright © 2015 Trilliant Incorporated. ALL RIGHTS RESERVED.

Table of Contents

1	Overview	5
2	Features and Specifications	5
2.1	<i>SecureMesh NAN Radio Performance</i>	5
2.2	<i>Electrical specifications</i>	5
2.3	<i>Physical, & Environmental</i>	6
2.4	<i>Compliance</i>	6
3	Functional Description	7
3.1	<i>OSDI Module</i>	7
3.2	<i>Host Interface & Optional IOs</i>	7
3.3	<i>Interface and Control Signals</i>	7
4	Antennas	9
4.1	<i>Antenna Placement</i>	9
4.2	<i>On board antennas</i>	10
4.3	<i>External antennas</i>	12
5	Host PCB Requirements	17
5.1	<i>Recommended Footprint</i>	17
5.2	<i>PasteMask</i>	17
5.3	<i>Layout requirements</i>	17
5.4	<i>Reference trace designs</i>	18
5.5	<i>Modifying the RF Signal Routing</i>	22
5.6	<i>Pin Numbering</i>	24
5.7	<i>Pin Description</i>	24
5.8	<i>Suggested Reflow profile, for reference only</i>	30
6	SecureMesh Configuration	30
6.1	<i>Mesh Programming tool</i>	30
6.2	<i>Data Link Library</i>	30
7	Regulatory Agency Approvals	31
7.1	<i>United States</i>	31
7.2	<i>Canada</i>	32

Figures

Figure 1: Typical application with OSDI Module	7
Figure 2: M Antenna orientation inside scanned product.....	10
Figure 3 M Antenna Azimuth (left) and Elevation (right) Patterns.....	10
Figure 4: uSplat Planar Antenna Picture.....	11
Figure 5: uSplat Antenna Radiation Patterns.....	11
Figure 6: Larsen RO2406NM Drawing.....	12
Figure 7: Larsen RO2406NM Radiation Patterns.....	12
Figure 8: MobileMark IMAG5-2400-3K-BLK-120.....	13
Figure 9: L-Com HG2403RD-RTF.....	14
Figure 10: L-Com HG2403RD-RTF Radiation Patterns.....	14
Figure 11: Mobile Mark CVS-2400.....	15
Figure 12: Mobile Mark CVS-2400 Radiation Patterns.....	15
Figure 13: Molex 1461530100.....	16
Figure 14 Molex 1461530100 Radiation Patterns.....	16
Figure 15 Footprint OSDI-4000-1X	17
Figure 16 FCC and IC approved trace design layout and picture for the M antenna of section 4.2.1	18
Figure 17 FCC and IC approved trace design layout and picture for the uSplash antenna of section 4.2.2	19
Figure 18 FCC and IC approved trace design layout and picture for external antennas of section 4.3	20
Figure 19 FCC and IC approved trace design layout and picture for external antennas of section 4.3	20
Figure 20 FCC and IC approved trace design layout and picture for external antennas	21
Figure 21 FCC and IC approved trace design layout and picture for external antennas	21
Figure 22 Coupon requirements to validate trace impedance.....	22
Figure 23: Micro-strip trace parameters	23
Figure 24: Example stack-up	23
Figure 25: 50 ohms calculation (mm) Trace width: 0.7mm Copper clearance: 0.1445mm	23
Figure 26: Pin Numbering Diagram Bottom view	24
Figure 27: Preliminary OSDI Module Reflow Profile and Set Points.....	30

Tables

Table 1: OSDI module control signals description and usage.....	7
Table 2 Antenna micro-strip trace parts for M antenna.....	19
Table 3 Antenna micro-strip trace parts for M antenna.....	19
Table 4 Antenna micro-strip trace parts for external antennas.....	20
Table 5 Antenna micro-strip trace parts for external antennas.....	21
Table 6 Antenna micro-strip trace parts for external antennas.....	21
Table 7 Antenna micro-strip trace parts for external antennas.....	22
Table 8: Pin numbering details.....	29

1 Overview

The SecureMesh Ready, Open Smart Device Interface Modules (OSDI) are Trilliant 2.4GHz RF modules which can be integrated into a variety of third party OEM products. These small and versatile modules include a microcontroller, memory, transceiver, power management all on an LGA circuit board.

Based on IEEE 802.15.4 wireless communication standard and utilizing Trilliant’s robust SecureMesh networking protocol, the OSDI modules deliver industry leading 2.4GHz networking solution. The modules are easy to integrate, provide low power consumption, long range and many more features and functionalities.

The OSDI family of products are currently available in 2 base hardware models:

Hardware Model	Description
OSDI-4000-1A	4 th generation OSDI module with maximum transmit power of 1 watt; ANSI protocol
OSDI-4000-1D	4 th generation OSDI module with maximum transmit power of 1 watt; DLMS/COSEM Protocol

Throughout the remainder of this document, the OSDI module platforms will be referred to by the base hardware model.

2 Features and Specifications

The OSDI modules are designed for a broad range of applications and products, and provide a compliant ready RF mesh solution for both domestic and international markets. The modules have a unique set of features, including:

- Reporting Retries and Acknowledgements.
- Remote Firmware upgrades.
- Programmable Network Parameters.
- AES, DES Encryption crypto module.
- Frequency hopping for a reliable communication link against interference (future enhancement)

2.1 SecureMesh NAN Radio Performance

Protocols	<ul style="list-style-type: none"> • SecureMesh NAN Transport layer • SecureMesh NAN Network layer • IEEE 802.15.4 MAC layer • IEEE 802.15.4 PHY layer (2.4 GHz)
Modulations	DSSS – OQPSK Direct Sequence Spread Spectrum Offset Quadrature Phase-Shift Keying Data rate: 250 kbps (transmit/receive)
Frequency band	2.400 - 2.4835 GHz (unlicensed operation)
Frequency channels	15
Channel spacing	5 MHz
Maximum transmit power	+30dBm
Receive sensitivity	-103dBm

2.2 Electrical specifications

	Min.	Typ.	Max.
Voltage	4.0	4.5	5.0
Current		1.2A	

2.3 Physical, & Environmental

Mounting method	LGA (Land Grid Array)
Dimensions (L x W x H)	29.8 x 35.3 x 4.4 mm
Operating temperature	-40 °C to +85 °C
Humidity	5 to 95% non-condensing

2.4 Compliance

Radio emissions	<ul style="list-style-type: none">• FCC Part 15 Class B• Industry Canada ICES-003 Class B• MID• others pending
Unlicensed radio operation	<ul style="list-style-type: none">• FCC Part 15.212, 15.247• Industry Canada RSS-Gen, RSS-247• MID• others pending
Human Exposure	<ul style="list-style-type: none">• FCC Part 2.1091, 2.1093• RSS-102

3 Functional Description

3.1 OSDI Module

The OSDI modules are low power 2.4GHz ISM band transceivers. Figure 1 below shows a block diagram of the OSDI-4000 modules and the surrounding optional functionalities that are intended as a reference implementation example.

The configuration of the transceiver, reading and writing of Frame Buffer is controlled by a SPI interface and additional control lines. The control of the RF front-end is done via the transceiver digital control pins.

The OSDI modules are equipped with a Low Drop Out voltage (LDO) regulator that enables them to work in standalone mode with a voltage supply between 4 and 5 volts.

The VCPU power supply line of the microcontroller is available on the external connection for optional backup supply when Real Time Power Outage Reporting (RTPOR) is required.

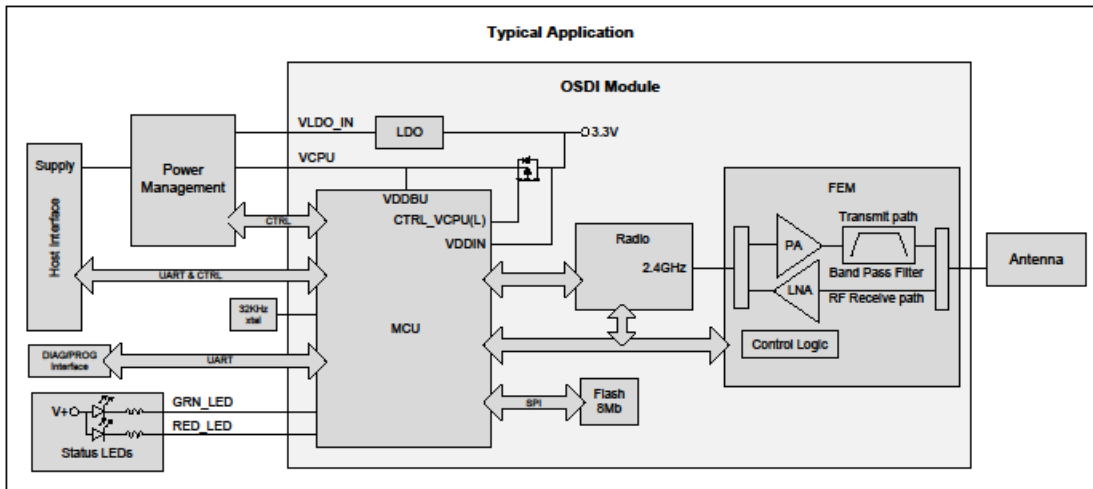

Figure 1: Typical application with OSDI Module

3.2 Host Interface & Optional IOs

Communication with the host is achieved using a serial communication port and control signals that are bundled with the power lines inside the host connector. Diagnostic and programming signals are available to the host. See Table 1 below for the description of the various signals found in the diagnostic and programming interface. The RF input/output signal must be routed through the host device as described in section 5.4. Antennas of section 4 can be used in relation with regulation. The OSDI module is designed with outputs to drive a multicolor LED indicator that allows visual diagnostic and status monitoring of the device. See Table 1 below for an interpretation of the existing LED patterns.

3.3 Interface and Control Signals

Table 1: OSDI module control signals description and usage.

Signal	Description	Usage
TX_EXT-RX_LGA	Transmit from the meter / Receive to the module. Signal Type: UART.	<ul style="list-style-type: none"> • Meter Connector serial port. • Meter USB Port. • Default baud rate is set to 9.6 kbps.
RX_EXT-TX_LGA	Receive to the meter / Transmit from the module. Signal Type: UART.	

Signal	Description	Usage
DIAG-RX_LGA	Module receive diagnostic port. Signal Type: UART.	<ul style="list-style-type: none"> Diagnostic serial port Diagnostic USB Port. Default baud rate is set to 9.6 kbps in diagnostic mode and 19.2 kbps in trace mode. Should be accessible via test points in normal design.
DIAG-TX_LGA	Module transmit diagnostic port. Signal Type: UART.	
RED_LED and GRN_LED	Control Red and Green LEDs. Signal Type: Active low output. 0=LED on, 1= LED off. Note: Red and green led are in one physical unit. Yellow is produced when both LEDs are on.	<ul style="list-style-type: none"> Diagnostic LEDs. Needs to be visible from the outside of the meter for installation purposes in normal design. <p>LEDs off: Power save mode/POR mode or no power. Flashing green: Initialization (5 sec). Steady Red: Working but not associated to a network. Steady Yellow: Working and trying to associate to a network. Steady Green: Working and associated to a network. Flashing Yellow: Working and exchanging info.</p>
P-FAIL_EXT	External signal from the meter indicating that an interruption of power has been detected. Signal Type: Active low input from the meter. 0 = Power fail, 1 = Normal condition.	<ul style="list-style-type: none"> Meter Connector. PFAIL Circuit. <p>Provides an early detection of power outage events.</p>
P-FAIL	Signal indicating that an interruption of power has been detected. Signal Type: Interrupt input. 0 = Power fail, 1 = Normal condition.	<ul style="list-style-type: none"> PFAIL Circuit. CPU Reset Control Circuit. <p>Provides early detection of power outage events.</p>
RESET	Signal Type: Hardware reset. 0 = Reset, 1 = Normal operation.	<ul style="list-style-type: none"> CPU Reset Control Circuit. For use during development only. Do not connect to the meter.
TEST	Select test / diagnostic mode. Signal Type: Active high input. 1 = Diagnostic mode, 0 = Normal mode.	<ul style="list-style-type: none"> Reserved Diagnostic/Programming Connector. Should be accessible via test points in normal design.
SC_HI	Signal Type: Input. 1 = Supercap voltage > 3.6V	<ul style="list-style-type: none"> On/off signal from the fail safe circuit to detect if the super cap is higher than 3.6V.
PWR_MON	Power supply monitoring signal. Signal Type: Analog.	<ul style="list-style-type: none"> Meter Connector. <p>Provision for self-detection of power outages by the OSDI modules, if P-FAIL is not available.</p>
RESET-PDI_CLK, TDI-PDI_DATA, TDO, TMS, TCK	Program and Debug Interface.	<ul style="list-style-type: none"> Diagnostic/Programming Connector. Used only during development. See schematic for proper use. Should be accessible via test points in normal design.
SLEEP	Sleep mode power activation. Signal Type: low open-drain output. 0 = SLEEP Enabled, 1 = SLEEP Disabled.	<ul style="list-style-type: none"> RTPOR Supply Management circuit. <p>Used to send the command to the power management circuit to connect the 1.5 Farad capacitor (+V1.5F) directly to the input supply (+VCPU) of OSDI module's CPU in order to feed it with minimum power waste, in sleep mode.</p>
MESURE_VCAP	1.5 Farad capacitor voltage monitoring. Signal Type: Analog, feeds ADC input.	Provision for monitoring of voltage level of the 1.5F capacitor.
+3.3V	LDO voltage regulator's output.	Regulated 3.3V voltage supply from the OSDI module.
+VMAIN	Main power supply input.	Used by the power management circuit as input to the LDO regulator and to charge the 1.5 Farad super capacitor.
+VCPU2	3.3 Volts supply for OSDI module's CPU.	Used to feed power to the CPU during debug and programming.
+VCPU	3.3 Volts supply for OSDI module's CPU.	Input supply (+VCPU) of OSDI module's CPU.
+VLDO_IN	LDO regulator's input.	Input of the LDO regulator (+VLDO) of the OSDI module.
+V1.5F_SW	1.5 Farad capacitor switched voltage.	Power path for the sleep mode power supply.

4 Antennas

The maximum output power authorized by the FCC and Industry Canada in the 2.4GHz band is 36 dBm EIRP. For the OSDI-4000-1x, the maximum output power of the radio is 30 dBm which can be combined to an antenna with a maximum gain of 6 dBi.

The OSDI module has been certified with many different types of integrated antennas as described in the following sections. The information shown was taken from datasheets or measured when mounted on specific products. Actual patterns will be influenced by the PCB layout and by surrounding material.

NOTE: Certification regulations differ from one country to the other. It remains the responsibility of the meter manufacturer to choose an antenna that will meet the requirements of the country where the meters will be deployed as well as any local certifications that may be required to comply with specific market regulations. See section 7 for more details.

4.1 Antenna Placement

Antenna performance is significantly impacted by the type and physical placement of the antenna. The antenna should be oriented in the device to properly radiate the RF emissions from the face of the device forward and in an upward direction for optimal connectivity to the Trilliant SecureMesh network infrastructure. In addition, there should be as few obstacles as possible between the antenna and the outside of the device.

Through the following examples, Trilliant is attempting to provide antenna options for the most commonly used antenna design scenarios but keep in mind that this is greatly dependent on the host device design. If you are unsure about which antenna to select, or how it should be implemented into the overall design, please contact Trilliant for guidance.

The RF connection from the OSDI module to the antenna is made using a 50 ohms micro-strip trace on the host's PCB. See section 5.4 for routing instructions.

4.2 On board antennas

4.2.1 'M' Antenna

Trilliant p/n: CP-0299A

		Chan. 18, P=28.7 dBm		
Plane	Polarization	Min (dBi)	Max (dBi)	Avg (dBi)
Azimuthal	Vertical	-23.1	3.6	-5.6
	Horizontal	-25.1	-8.5	-15.7
Elevation	Vertical	-30.7	-12.3	-19.0
	Horizontal	-21.5	4.8	-7.7

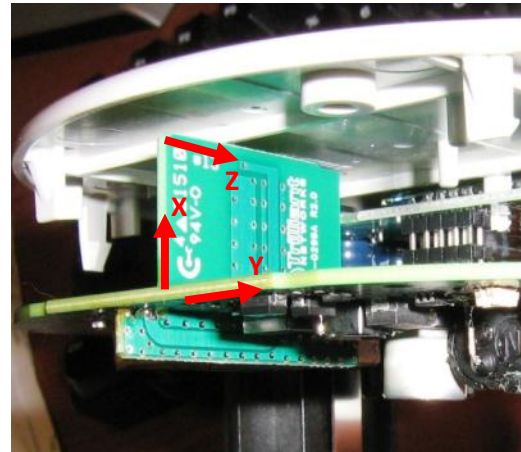

Figure 2: M Antenna orientation inside scanned product.

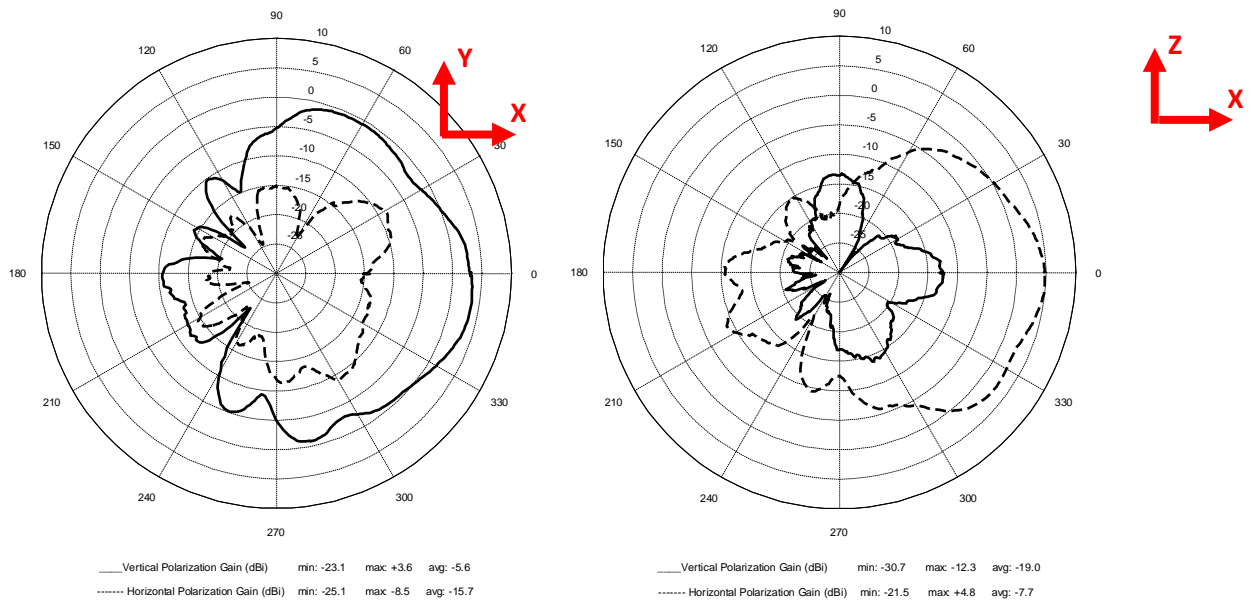

Figure 3 M Antenna Azimuth (left) and Elevation (right) Patterns.

4.2.2 uSplatch planarAntenna

Linx #: ANT-2.4-uSP
 Center frequency: 2.4 GHz
 Bandwidth: 150 MHz
 Wavelength: ¼-wave
 VSWR: ≤ 2.0 typical at center
 Peak gain: 3.8 dBi
 Impedance: 50 ohms



Figure 4: uSplatch Planar Antenna Picture.

Gain Plots

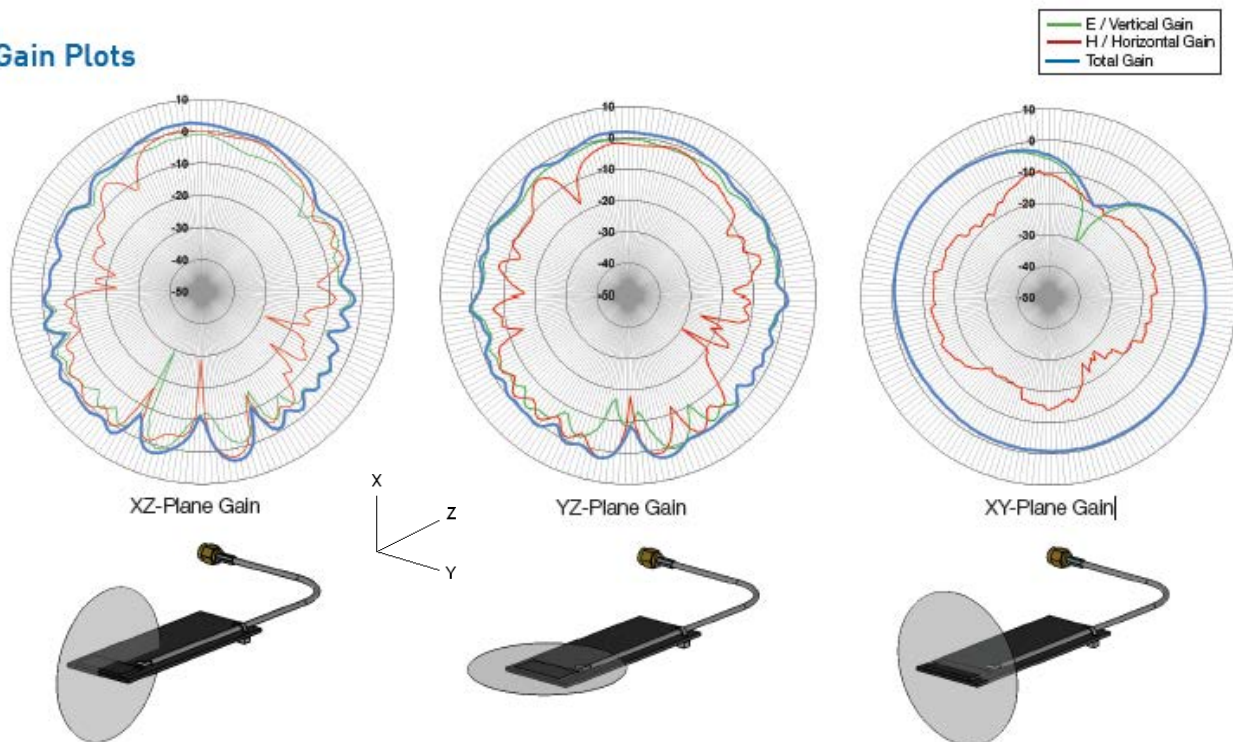

Figure 5: uSplatch Antenna Radiation Patterns.

4.3 External antennas

The following section describes types of external antennas that have been certified with the OSDI-4000 module. Note that a Reverse Polarity connector must be used for external antennas.

4.3.1 Larsen RO2406NM

Vendor: Larsen

Vendor #: RO2406NM

Frequency: 2400-2500 MHz

Nominal Impedance: 50 Ohms

VSWR: 2:1 Max

Gain: 6 dBi

Polarization: Vertical

Power withstanding: 20 W

Connector: N-Type Male (To use this antenna with the OSDI module, a RP connector that is actually in discussion, must be used; the part number will change accordingly)

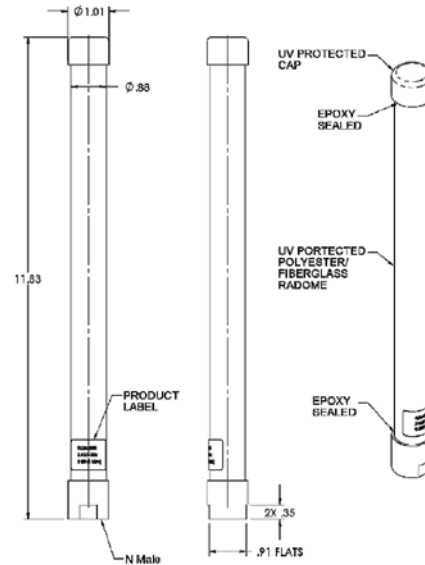

Figure 6: Larsen RO2406NM Drawing.

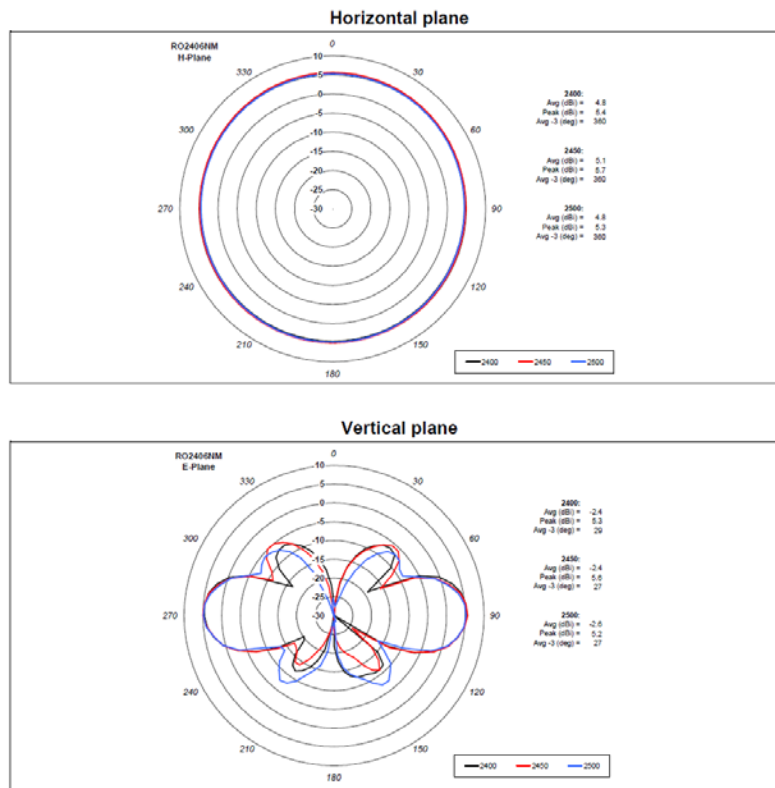

Figure 7: Larsen RO2406NM Radiation Patterns.

4.3.2 MobileMark IMAG5-2400

Vendor: MobileMark

Vendor #: IMAG5-2400-3K-BLK-120

Frequency: 2400-2485 MHz

Nominal Impedance: 50 Ohms

VSWR: 2:1 over band

Gain: 5 dBi

Maximum Power: 10 Watts

Connector: TNC Plug-RP (female center pin)

Temperature: -40°C to +85°C



IMAG5 Series

Figure 8: MobileMark IMAG5-2400-3K-BLK-120.

4.3.3 L-Com HG2403RD-RTF

Vendor = L-Com Global Connectivity

Vendor #: HG2403RD-RTF

Frequency: 2400 – 2 500 MHz

Gain: 3 dBi max

VSWR:<2.0

Impedance: 50 ohm

Polarization: Vertical

Connector: TNC Plug-RP (female center pin)

Temperature Range: -40° to +85°C



Figure 9: L-Com HG2403RD-RTF.

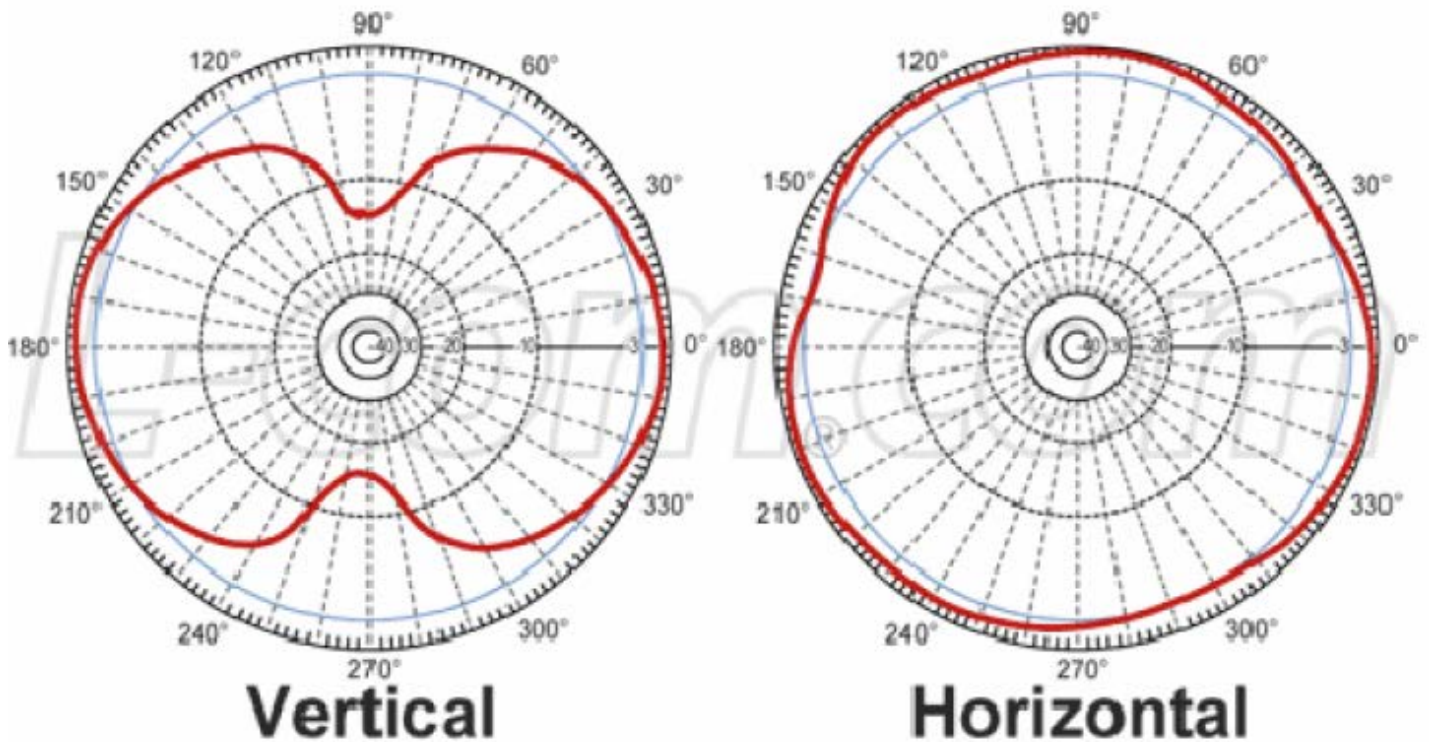

Figure 10: L-Com HG2403RD-RTF Radiation Patterns.

4.3.4 Mobile Mark CVS-2400

Vendor = Mobile Mark
Vendor #: CVS-2400-2SA-BLK-13
Frequency: 2.4 – 2.5 GHz
Gain: 2.0 dBi max
VSWR: 2:1 over band
Impedance: 50 ohm nominal
Maximum Power: 10 Watts
Connector: SMA Plug-RP
Temperature Range: -40° to +85°C

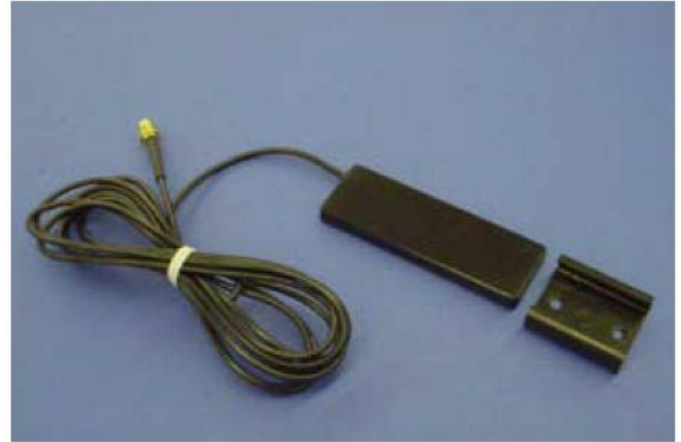

Figure 11: Mobile Mark CVS-2400.

Antenna Dimensions:

3 3/4" Length x 1 1/4" Width x 3/8" Deep
(95 mm x 32 mm x 9 mm)

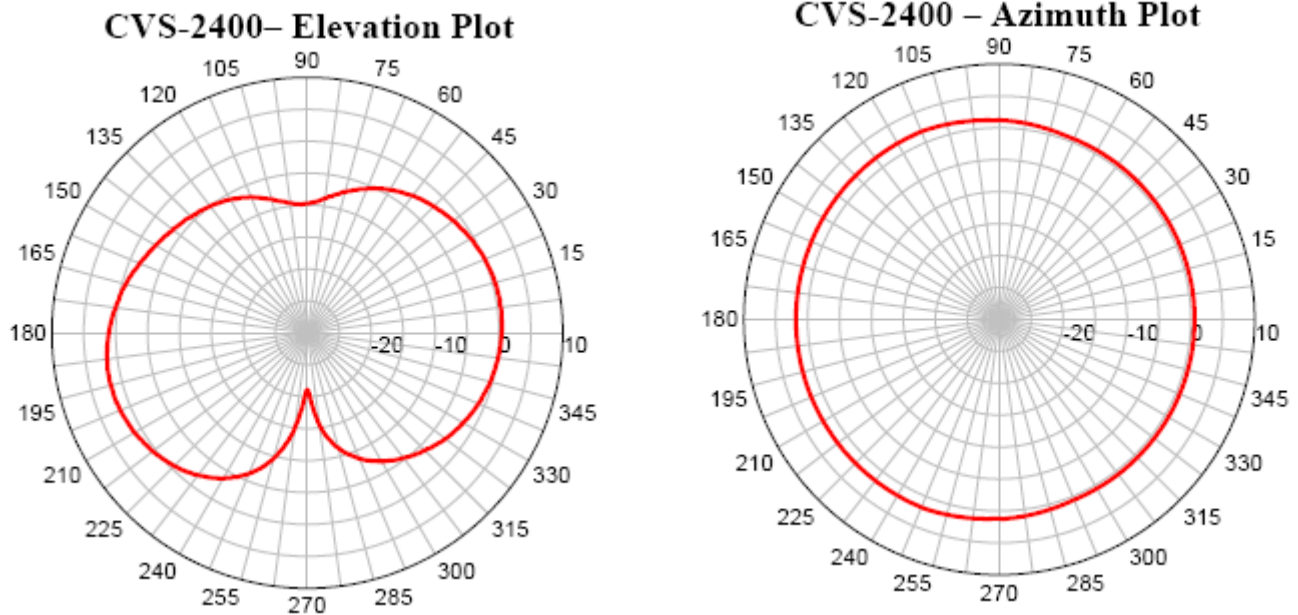

Figure 12: Mobile Mark CVS-2400 Radiation Patterns.

4.3.5 Molex 1461530100

Vendor = Molex
 Vendor #: 1461530100
 Frequency: 2.4 / 5 GHz
 Peak Gain: 3.0 dBi at 2.4 GHz
 4.5 dBi at 5 GHz
 Impedance: 50 ohm nominal
 Maximum Power: 2 Watts
 Connector: U.FL
 Temperature Range: -30° to +85°C



Figure 13: Molex 1461530100.

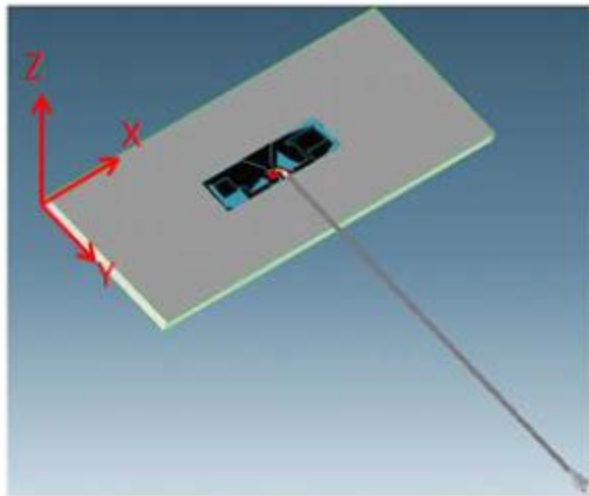

XY-2450MHz

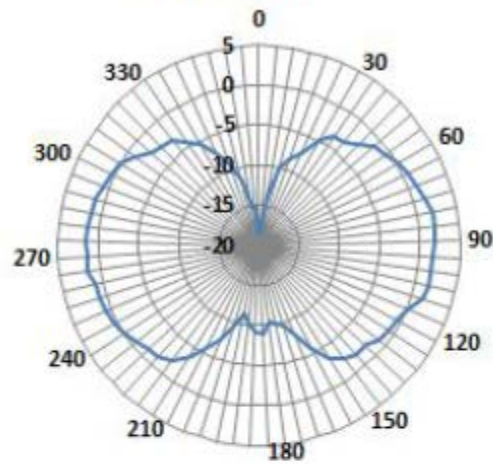

YZ-2450MHz

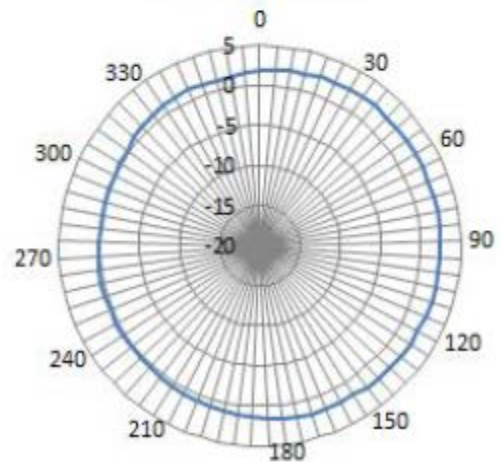

XZ-2450MHz

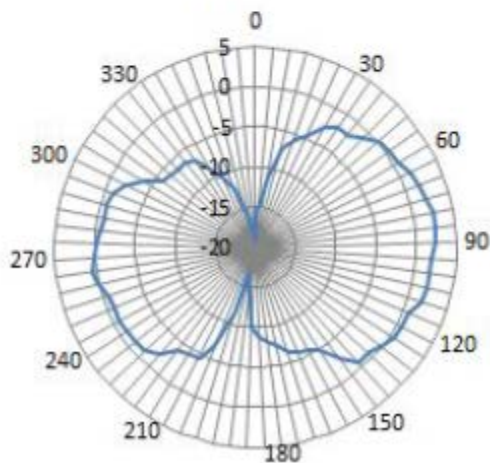

Figure 14 Molex 1461530100 Radiation Patterns.

5 Host PCB Requirements

5.1 Recommended Footprint

The footprints shown below are available upon request as a PAD Layout source file.

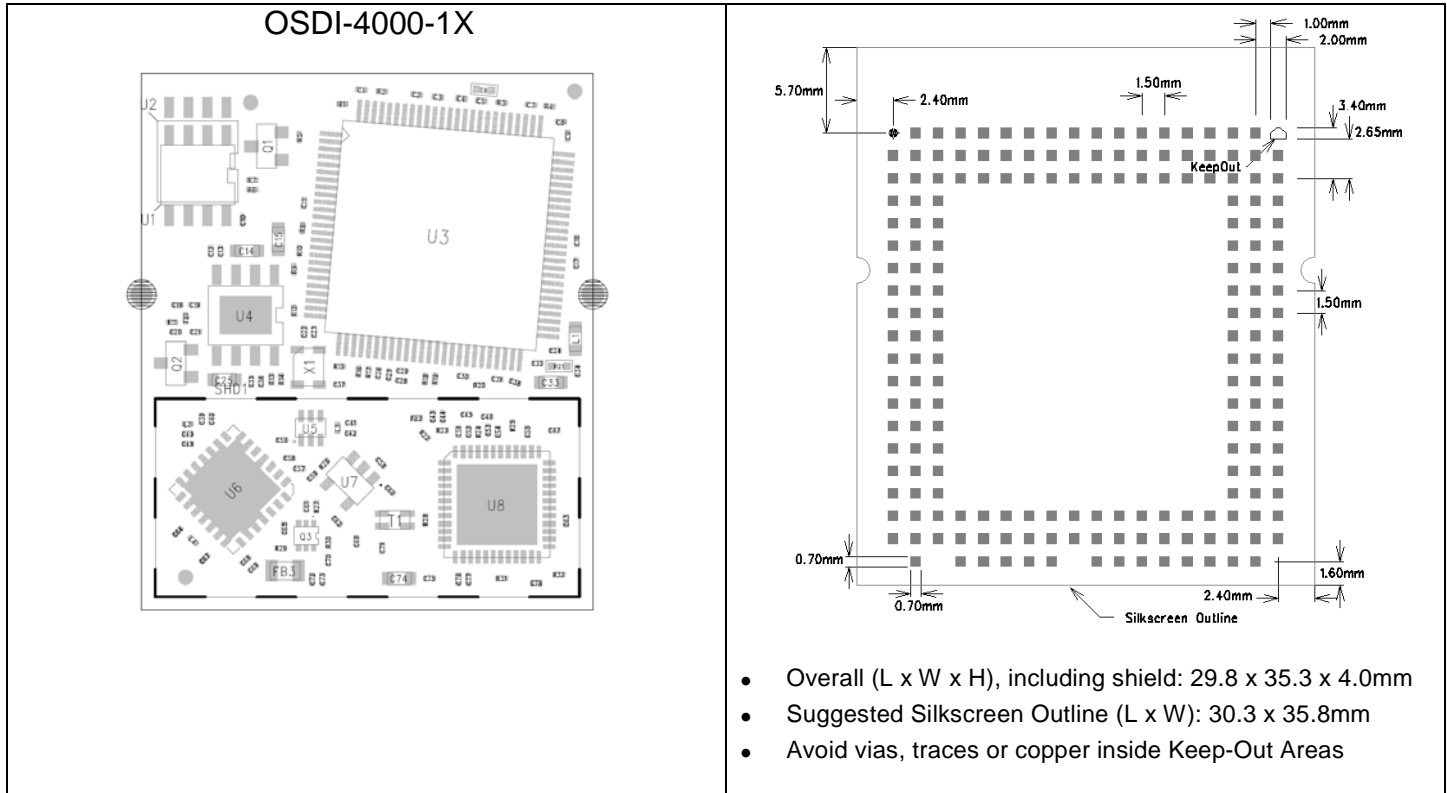

Figure 15 Footprint OSDI-4000-1X

5.2 PasteMask

Paste Mask Stencil openings can be of the same size as the recommended footprint (1:1); suggested thickness of stencil foil $\geq 120\mu\text{m}$.

5.3 Layout requirements

- Traces routed to RF_EXT pad must be 50 ohm.
- Traces current rating:

+VCPU	$\geq 90 \text{ mA}$
+3.3V	$\geq 90 \text{ mA}$
+VLDO_IN	$\geq 1.4 \text{ Amp}$
+V1.5F_SW	$\geq 90\text{mA}$

- Thermal reliefs are strongly recommended for all pads connected to Ground net.
- Finish recommendation for PCB pad surfaces: ROHS Compliant (EU Directive 2002/95/EC) 2-10 μIN Immersion Gold Over 50-200 μIN Electro less Nickel (ENIG)
- Non Solder Mask Defined (NSMD) type is recommended for the solder pads on the PCB.

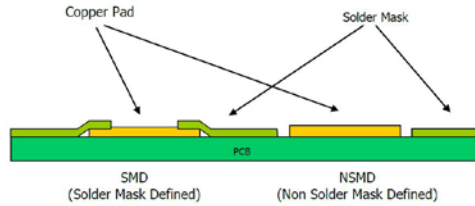

- Pads Solder Mask Opening of 0.1mm is recommended.

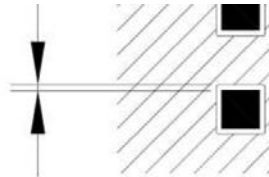

5.4 Reference trace designs

RF traces from OSDI module pads W10 and W16 to the antenna must be made using micro-strip traces. This micro-strip trace must respect the design of the Gerber files associated with the following designs in order to obtain a uniform transmission line with a characteristic impedance of 50 ohms. The reference trace designs are shown in the following sections.

5.4.1 Layout and parts for M antenna

The reference trace for this antenna is the green traces along with the side copper filled with vias on the left side of Figure 16 where components G8, G9, G11 and G12 are not installed. As preliminary information the traces width of all sections are 0.27mm and the length of each section, starting from the LGA pad to the M antenna are: LGA pad to G7: 15.38mm; G7 to G10: 12.37mm; G10 to R50: 2.3mm; R50 to M antenna: 4.85mm. However, refer to associated Gerber files for more accurate details on dimensions and refer to Trilliant Networks Inc for more details on the Gerber files. Table 2 shows the parts used in this reference trace design.

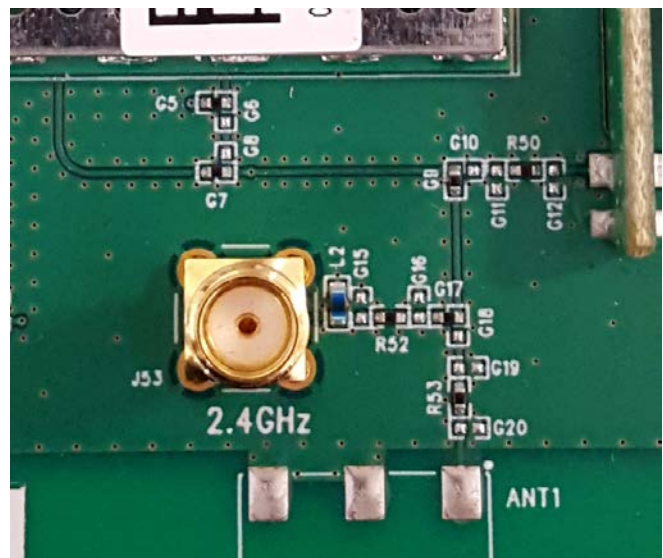
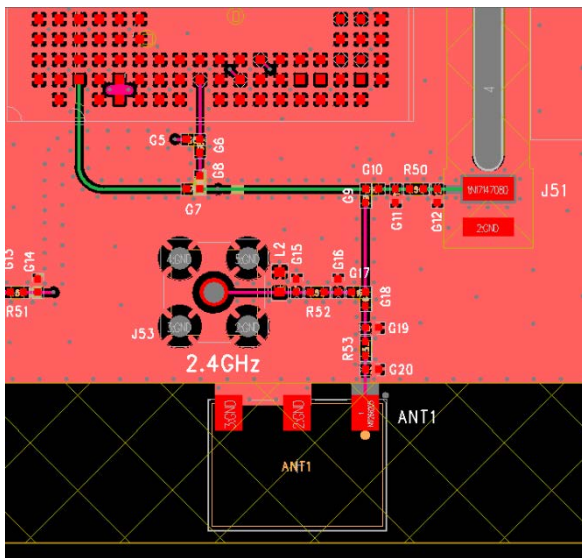

Figure 16 FCC and IC approved trace design layout and picture for the M antenna of section 4.2.1

Table 2 Antenna micro-strip trace parts for M antenna

Part Number	Designator	Description	Manufacturer
N/A	G8, G9, G11, G12	Not installed	N/A
RK73Z1ETTP	G7, G10, R50	RESISTOR 0.0 OHMS 1/16W 5% 0402 SMT	KOA Speer Electronics
CP-0299A	J51	Trilliant M antenna	Trilliant

5.4.2 Layout and parts for uSplash antenna

The reference trace for this antenna is the green traces along with the side copper filled with vias on the left side of Figure 17 where components G8, G10, G17, G19 and G20 are not installed. As preliminary information the traces width of all sections are 0.27mm and the length of each section, starting from the LGA pad to the uSplash are: LGA pad to G7: 15.38mm; G7 to G9: 12.37mm; G9 to G17: 6.7mm; G17 to R53: 2.1mm and R53 to uSplash antenna: 7.2mm. However, refer to associated Gerber files for more accurate details on dimensions and refer to Trilliant Networks Inc for more details on the Gerber files. Table 3 shows the parts used in this reference trace design.

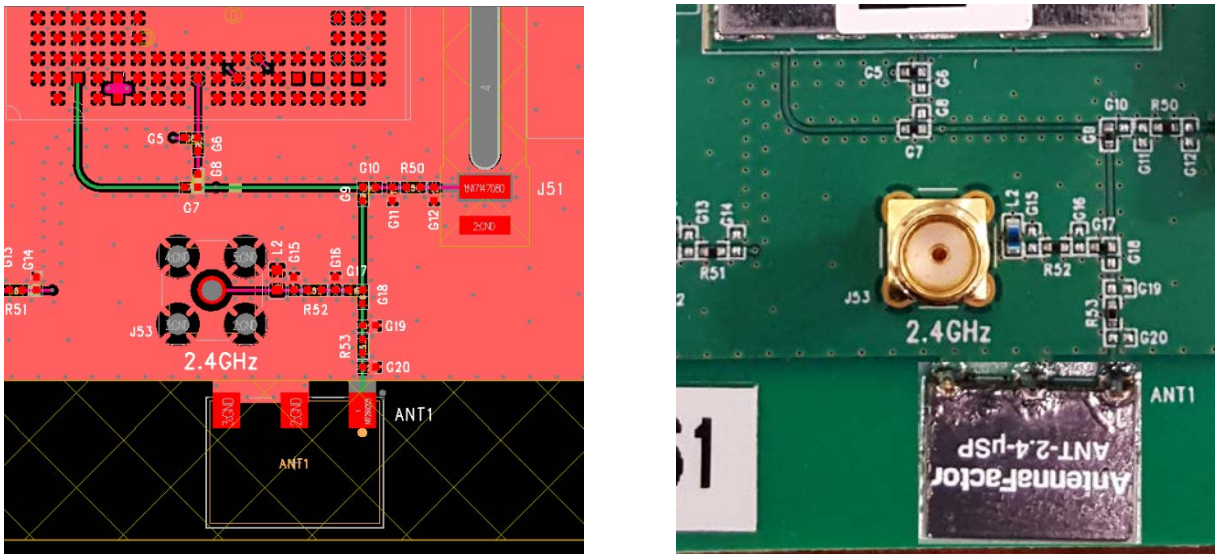

Figure 17 FCC and IC approved trace design layout and picture for the uSplash antenna of section 4.2.2

Table 3 Antenna micro-strip trace parts for M antenna

Part Number	Designator	Description	Manufacturer
N/A	G8, G9, G11, G12	Not installed	N/A
RK73Z1ETTP	G7, G9, G18, R53	RESISTOR 0.0 OHMS 1/16W 5% 0402 SMT	KOA Speer Electronics
ANT-2.4-uSP	ANT1	PC mount quarter-wave antenna	Linx

5.4.3 Layout and parts for external antennas

The reference traces for these antennas are the green traces along with the side copper filled with vias on the left side of Figure 18 where components G8, G10, G15, G16 and G18 are not installed, the left side of Figure 19 where G4 is not install, the pink trace on the left side of Figure 20 where R13 and R15 are not installed and the left side of Figure 21 where G1 and G2 are not installed.

As preliminary information for Figure 18 the traces width of all sections are 0.27mm and the length of each section, starting from the LGA pad to J53 connector are: LGA pad to G7: 15.38mm; G7 to G9: 12.37mm; G9 to G17: 6.7mm; G17 to R52: 2.1mm; R52 to J53: 7.2mm.

However, refer to associated Gerber files for more accurate details on dimensions and refer to Trilliant Networks Inc for more details on the Gerber files. Table 4 shows the parts used in the reference trace design.

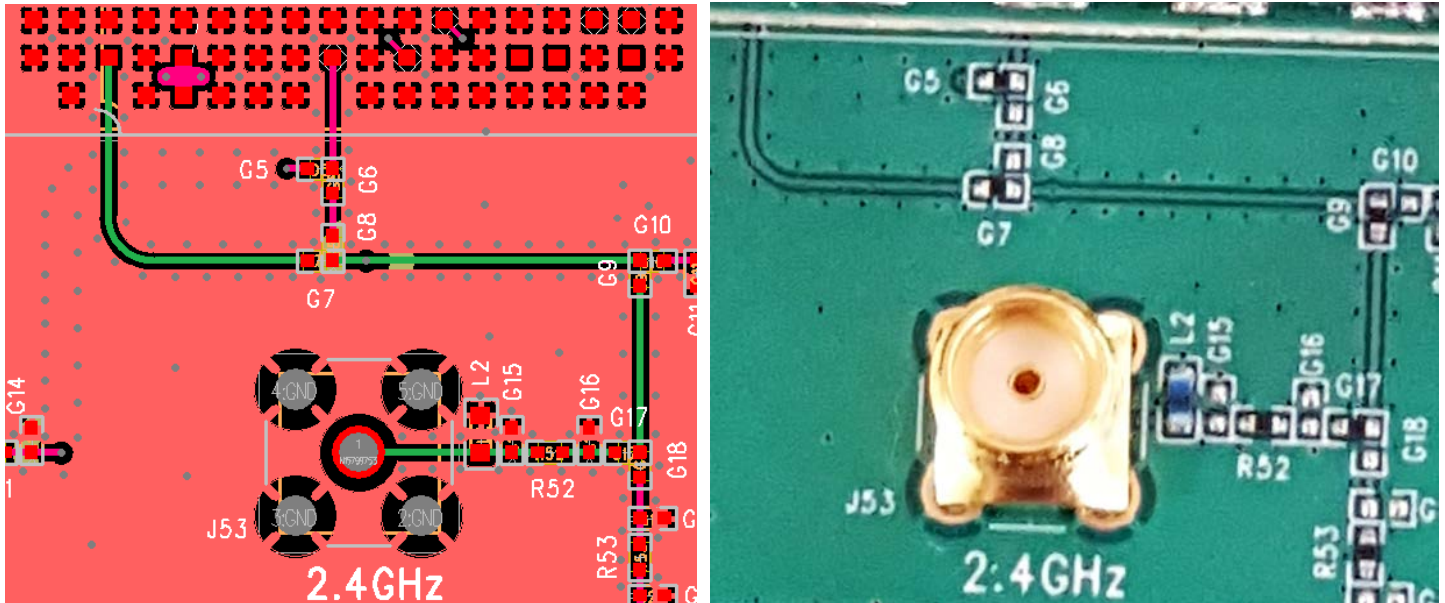

Figure 18 FCC and IC approved trace design layout and picture for external antennas of section 4.3

Table 4 Antenna micro-strip trace parts for external antennas

Part Number	Designator	Description	Manufacturer
N/A	G8, G10, G15, G16, G18	Not installed	N/A
RK73Z1ETTP	G7, G9, G17, R52	RESISTOR 0.0 OHMS 1/16W 5% 0402 SMT	KOA Speer Electronics
LQW18AN75NG00D	L2	INDUCTOR 75nH, 2%, 270mA 560mΩ, 0603 SMT	Murata Manufacturing
1-1478979-0	J53	SMA JACK CONNECTOR (FEMALE) PCB Mount 4 legs, SS/Gold pl.	TE Connectivity

As preliminary information for Figure 19, the traces width of all sections are 1mm and the length of each section, starting from the LGA pad to J5 connector are: LGA pad to G3: 14.18mm; G3 to J5: 5.05mm. However, refer to associated Gerber files for more accurate details on dimensions and refer to Trilliant Networks Inc for more details on the Gerber files. Table 5 shows the parts used in the reference trace design.

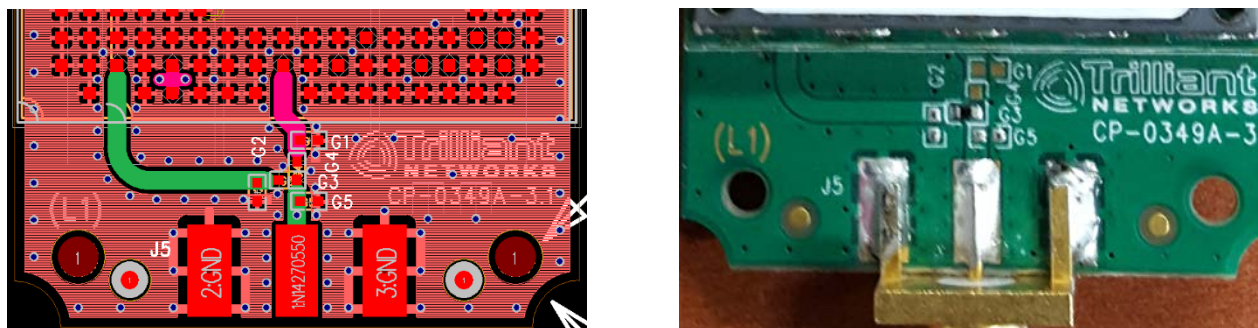

Figure 19 FCC and IC approved trace design layout and picture for external antennas of section 4.3

Table 5 Antenna micro-strip trace parts for external antennas

Part Number	Designator	Description	Manufacturer
N/A	G4	Not installed	N/A
RK73Z1ETTP	G3	RESISTOR 0.0 OHMS 1/16W 5% 0402 SMT	KOA Speer Electronics
142-0701-801	J5	SMA End Launch Jack receptacle (FEMALE) Round Contact, Gold pl.	Johnson Components

As preliminary information for Figure 20, the traces width of all sections is 0.6mm and the length of each section, starting from the LGA pad to J4 connector are: LGA pad to R14: 14.7mm; R14 to J4: 2.1mm. However, refer to associated Gerber files for more accurate details on dimensions and refer to Trilliant Networks Inc for more details on the Gerber files. Table 6 shows the parts used in the reference trace design.

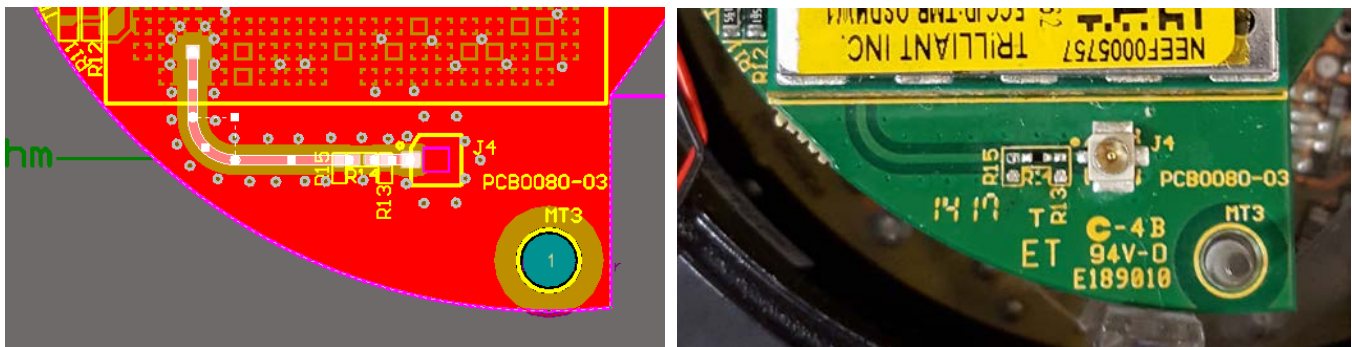

Figure 20 FCC and IC approved trace design layout and picture for external antennas

Table 6 Antenna micro-strip trace parts for external antennas

Part Number	Designator	Description	Manufacturer
ESR01MZPJ391	R13, R15	RES SMD 390 OHM 5% 1/5W 0402	Rohm Semiconductor
CRCW040210R7FKEDHP	R14	RES SMD 10.7 OHM 1% 1/5W 0402	Vishay
73412-0110	J4	JACK, U.FL, Straight, PCB, SMT	Molex

As preliminary information for Figure 21, the traces width of all sections is 0.2mm and the length of each section, starting from the LGA pad to J7 connector are: LGA pad to R18: 11.82mm; R18 to J7: 5.2mm. However, refer to associated Gerber files for more accurate details on dimensions and refer to Trilliant Networks Inc for more details on the Gerber files. Table 7 shows the parts used in the reference trace design.

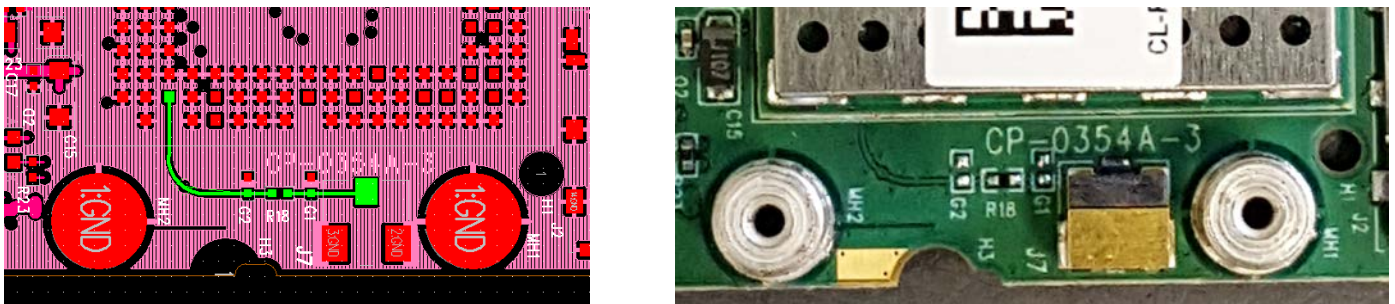

Figure 21 FCC and IC approved trace design layout and picture for external antennas

Table 7 Antenna micro-strip trace parts for external antennas

Part Number	Designator	Description	Manufacturer
N/A	G1, G2	Not installed	N/A
RK73Z1ETTP	R18	RESISTOR 0.0 OHMS 1/16W 5% 1005/0402 SMT	KOA Speer Electronics
6-1460820-2	J7	MMCX CONNECTOR RIGHT ANGLE JACK (female), Tin pl. SMT	TE Connectivity

5.4.4 Design validation & production procedures

To verify compliance of the reference trace, a coupon must be requested with every manufacturing panel form and for which the characteristics are described in the Gerber files. Part of these characteristic are shown in Figure 22. Then a network analyzer is used to measure the impedance of this coupon in order to validate the antenna trace.

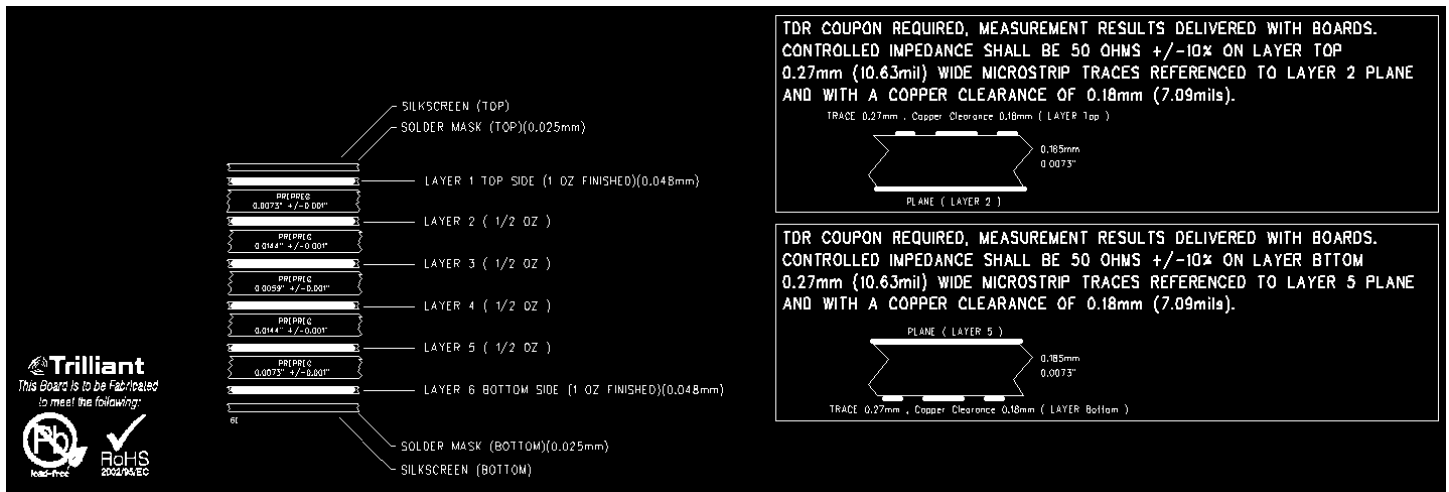

Figure 22 Coupon requirements to validate trace impedance

5.4.5 Other considerations

The only antennas, also describe in section 4.3, that can be used with the module using the reference trace design are the:

- Trilliant, CP-0299A, 4.8 dBi
- Linx, ANT-2.4-uSP, 3.8 dBi
- Larsen Antenna, RO2406NM, 6 dBi
- Mobile Mark, IMAG5-2400-3K-BLK-120, 5 dBi
- L-Com, HG2403RD-RTF, 3 dBi
- Mobile Mark, CVS-2400, 2.5 dBi
- Molex 1461530100, 3 dBi

The use of any other antenna or any changes to the reference trace design are subject to additional testing and authorization through a Class II permissive change.

5.5 Modifying the RF Signal Routing

As previously mentioned, any changes to the RF traces is subject to approbation, additional testing and authorization through a Class II permissive change on the FCC and IC grants.

The objective is to use the W10 and W16 pads from OSDI module to route a micro-strip traces in order to obtain a uniform transmission line with a characteristic impedance of 50 ohms. The characteristic impedance depends on the geometry of the trace and on the relative

dielectric constant of the PCB as shown in Figure 23. However, the characteristic impedance does not depend on the length of the trace. Many tools are available on the web to help calculate the optimum dimensions.

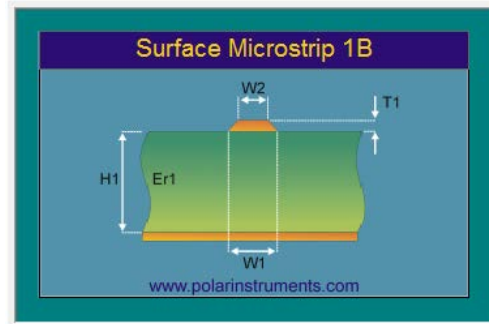

Figure 23: Micro-strip trace parameters

H1 and T1 are taken from the stack-up parameter of the host's PCB as shown in Figure 24, the relative dielectric constant depend on the material used.

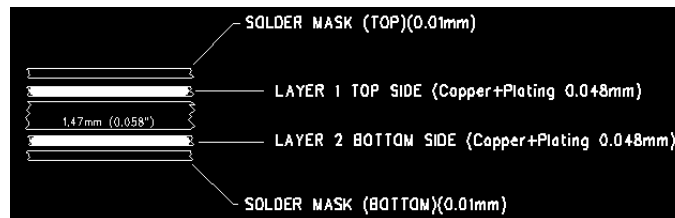
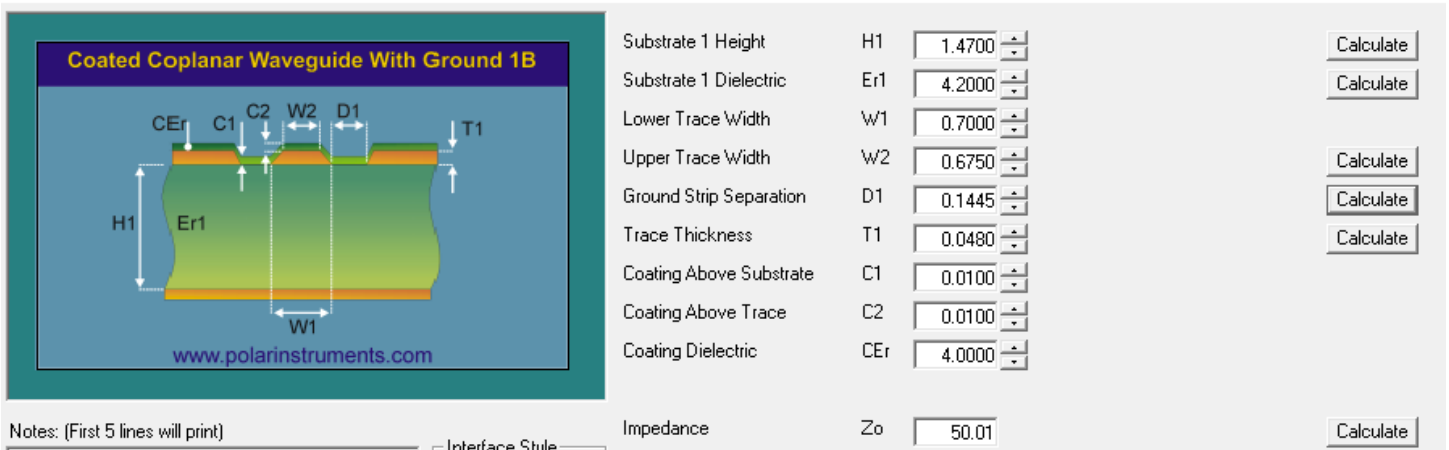

Figure 24: Example stack-up

An example stack-up, copper thickness, RF traces width and traces to copper clearance in order to get 50 ohms is presented below. The calculation tool is then used to find the remaining parameters of the micro-strip traces as shown in Figure 25.



Substrate 1 Height	H1	1.4700	Calculate		
Substrate 1 Dielectric	Er1	4.2000	Calculate		
Lower Trace Width	W1	0.7000			
Upper Trace Width	W2	0.6750	Calculate		
Ground Strip Separation	D1	0.1445	Calculate		
Trace Thickness	T1	0.0480	Calculate		
Coating Above Substrate	C1	0.0100			
Coating Above Trace	C2	0.0100			
Coating Dielectric	CEr	4.0000			
Notes: (First 5 lines will print)	Interface Style	Impedance	Zo	50.01	Calculate

Figure 25: 50 ohms calculation (mm) Trace width: 0.7mm Copper clearance: 0.1445mm

The resulting parameters can then be used to define the trace width and copper clearance on RF traces of the host's PCB. The RF traces must be surrounded by copper all along the path of undefined length; the path should be as short as possible to reduce losses. Vias must be added all along the RF traces. See reference trace design in Figure 18 for an example.

Note: a new trace design is subject to validation, additional testing and authorization through a Class II Permissive change on the FCC and IC grants.

5.6 Pin Numbering

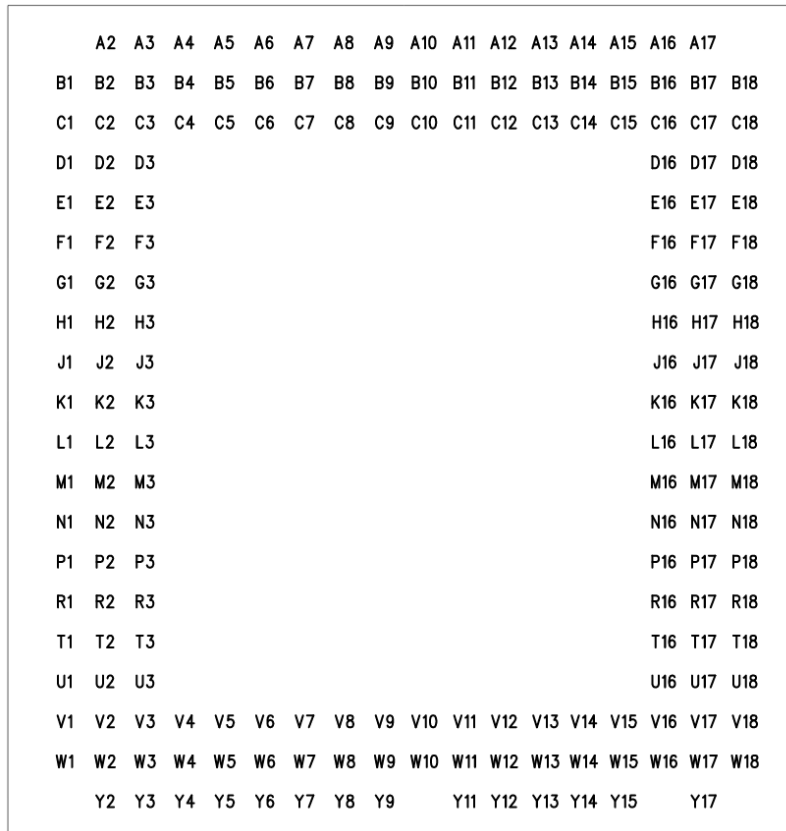

Figure 26: Pin Numbering Diagram
Bottom view

5.7 Pin Description

Pad	Name	Description
A2	*8_NRST	Test point only
A3	PB31	Do not connect
A4	PB23/AD4	Spare I/O
A5	PA12/AD0	Spare I/O
A6	RESERVED	Do not connect
A7	+VCPU	+VCPU
A8	*12_PA16	Spare I/O
A9	PB28	Spare I/O
A10	PB4/RX0	Test point only
A11	PB5/TX0	Test point only
A12	PB7	Status LED
A13	RESERVED	Do not connect

Pad	Name	Description
A14	+VCPU	+VCPU
A15	RESERVED	Do not connect
A16	PA0_*1	Spare I/O
A17	*1_PB26	Spare I/O
B1	PA13/SCK_EXT1	Provision for external SPI
B2	PA14/CS_EXT1	Provision for external SPI
B3	PA15	Spare I/O
B4	PB27	Power management signal
B5	RESERVED	Do not connect
B6	RESERVED	Do not connect
B7	RESERVED	Do not connect
B8	RESERVED	Do not connect
B9	PA2_*5	Spare I/O
B10	RESERVED	Do not connect
B11	SHDN	Power management signal
B12	PB8	Status LED
B13	PB25	Spare I/O
B14	PB10_*4	Spare I/O
B15	PB14_*5	Spare I/O
B16	PB11_*6	Spare I/O
B17	PB12_*1	Spare I/O
B18	PB16/MISO_EXT2_*2	Spare I/O
C1	PA10/MOSI_EXT1	Provision for external SPI
C2	PB1/TDO_*11	Spare I/O
C3	RESERVED	Do not connect
C4	PA17/PFAIL	Power management signal
C5	RESERVED	Do not connect
C6	RESERVED	Do not connect
C7	RESERVED	Do not connect
C8	RESERVED	Do not connect
C9	RESERVED	Do not connect
C10	RESERVED	Do not connect
C11	+VCPU	+VCPU
C12	GND_NC	Do not connect
C13	PB29	Spare I/O
C14	RESERVED	Do not connect
C15	PC0/TX1	Meter interface

Pad	Name	Description
C16	RESERVED	Do not connect
C17	RESERVED	Do not connect
C18	RESERVED	Do not connect
D1	PA9/MISO_EXT1	Provision for external SPI
D2	PB3/TCK_*11	Spare I/O
D3	PB2/TMS_*11	Spare I/O
D16	GND_NC	Do not connect
D17	RESERVED	Do not connect
D18	PC1/RX1	Meter interface
E1	*9_NRST	Test point only
E2	RESERVED	Do not connect
E3	PB13/AD3	Power management signal
E16	PA19/CS_EXT2_*2	Spare I/O
E17	PB18/SCK_EXT2_*2	Spare I/O
E18	PB17/MOSI_EXT2_*2	Spare I/O
F1	PB0/TDI	Spare I/O
F2	PA4/AD1	Power management signal
F3	RESERVED	Do not connect
F16	RESERVED	Do not connect
F17	RESERVED	Do not connect
F18	+VLDO_IN	Input of LGA LDO
G1	RESERVED	Do not connect
G2	*3_PC5	Spare I/O
G3	+VCPU	+VCPU
G16	GND_NC	Do not connect
G17	GND_NC	Do not connect
G18	+VLDO_IN	Input of LGA LDO
H1	RESERVED	Do not connect
H2	GND_NC	Do not connect
H3	RESERVED	Connected to Gnd via 0 ohms resistor.
H16	GND_NC	Do not connect
H17	GND_NC	Do not connect
H18	GND_NC	Do not connect
J1	GND_NC	Do not connect
J2	GND_NC	Do not connect
J3	RESERVED	Connected to Gnd via 0 ohms resistor.
J16	GND_NC	Do not connect

Pad	Name	Description
J17	GND_NC	Do not connect
J18	GND_NC	Do not connect
K1	GND_NC	Do not connect
K2	GND_NC	Do not connect
K3	RESERVED	Do not connect
K16	RESERVED	Do not connect
K17	RESERVED	Do not connect
K18	XIN32	32KHz xtal
L1	GND_NC	Do not connect
L2	GND_NC	Do not connect
L3	GND_NC	Do not connect
L16	PB15_*13	Spare I/O
L17	+3.3V	Output from LGA LDO
L18	XOUT32	32KHz xtal
M1	GND	GND
M2	RESERVED	Do not connect
M3	GND_NC	Do not connect
M16	GND	GND
M17	GND	GND
M18	+V1.5F_SW	LGA backup power
N1	GND	GND
N2	GND_NC	Do not connect
N3	GND	GND
N16	GND	GND
N17	GND	GND
N18	+3.3V	Output from LGA LDO
P1	GND	GND
P2	GND_NC	Do not connect
P3	GND_NC	Do not connect
P16	GND	GND
P17	GND	GND
P18	+3.3V	Output from LGA LDO
R1	GND	GND
R2	GND_NC	Do not connect
R3	GND	GND
R16	GND	GND
R17	GND	GND

Pad	Name	Description
R18	GND	GND
T1	GND	GND
T2	GND_NC	Do not connect
T3	GND_NC	Do not connect
T16	GND	GND
T17	GND	GND
T18	GND	GND
U1	GND	GND
U2	GND	GND
U3	GND	GND
U16	GND	GND
U17	GND	GND
U18	GND	GND
V1	GND	GND
V2	GND_NC	Do not connect
V3	RESERVED	Do not connect
V4	GND	GND
V5	GND	GND
V6	GND	GND
V7	RESERVED	Do not connect
V8	GND	GND
V9	GND	GND
V10	GND	GND
V11	GND	GND
V12	GND	GND
V13	GND	GND
V14	GND	GND
V15	GND	GND
V16	GND	GND
V17	GND	GND
V18	GND	GND
W1	GND	GND
W2	GND_NCRESERVED	Do not connect
W3	GND	GND
W4	RESERVED	Do not connect
W5	RESERVED	Do not connect
W6	GND	GND

Pad	Name	Description
W7	RESERVED	Do not connect
W8	RESERVED	Do not connect
W9	GND	GND
W10	RESERVED	Do not connect
W11	GND	GND
W12	GND	GND
W13	GND	GND
W14	RESERVED	Do not connect
W15	GND	GND
W16	RF_EXT1	RF to/from antenna
W17	GND	GND
W18	GND	GND
Y2	GND	GND
Y3	GND	GND
Y4	GND	GND
Y5	GND	GND
Y6	GND	GND
Y7	GND	GND
Y8	GND	GND
Y9	GND	GND
Y11	GND	GND
Y12	GND	GND
Y13	GND	GND
Y14	RESERVED	Do not connect
Y15	GND	GND
Y17	GND	GND

Table 8: Pin numbering details.

5.8 Suggested Reflow profile, for reference only

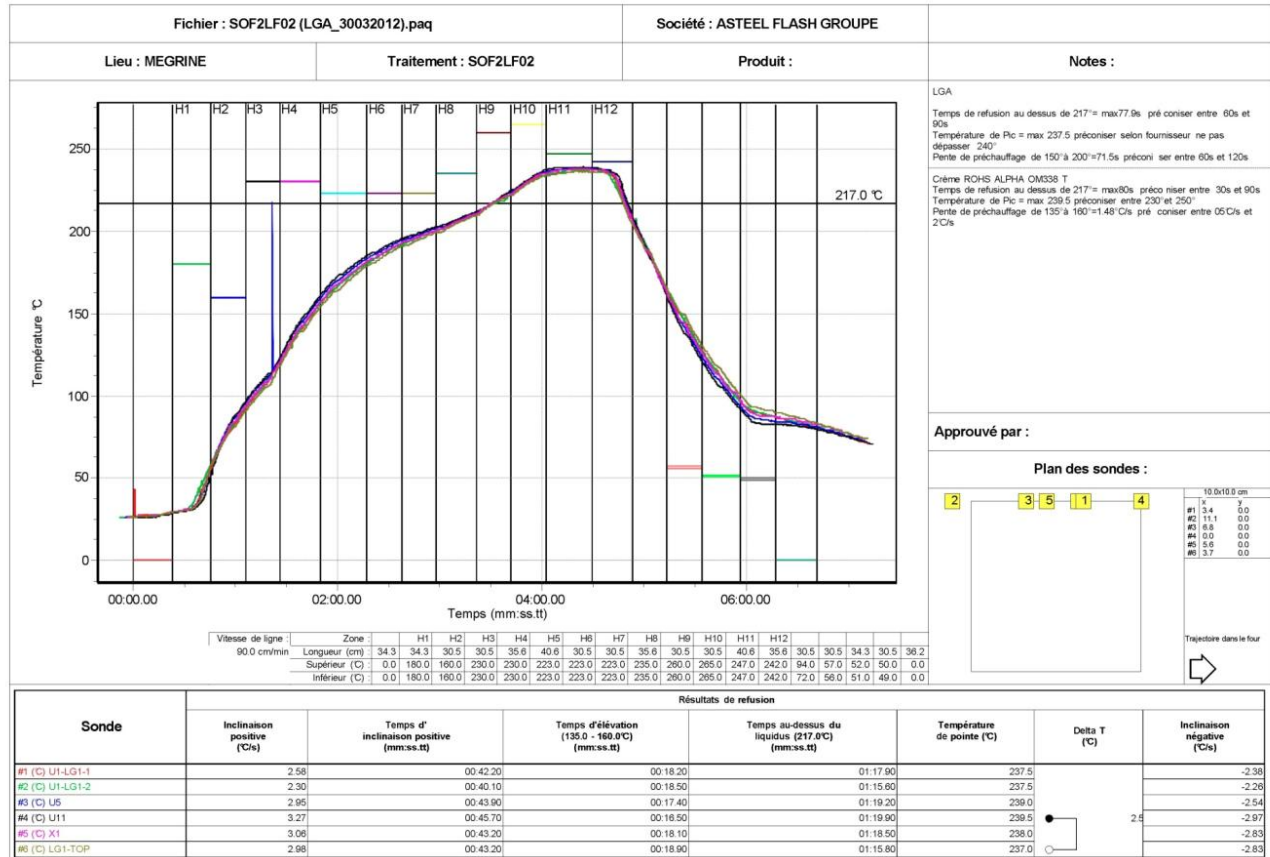

Figure 27: Preliminary OSDI Module Reflow Profile and Set Points.

6 SecureMesh Configuration

The configuration of the OSDI module is the last step in the manufacturing process, just before shipping to the customer. This process consists of configuring of programming the customer related parameters as applicable, via the SecureMesh network, using the Mesh Programming tool.

6.1 Mesh Programming tool

Trilliant's Mesh Programming tool is an MS Windows application that communicates with the OSDI modules using a SecureMesh USB radio dongle.

The configuration file is generated by Trilliant for each deployment project to define the configuration parameters for each OSDI module in a given SecureMesh network.

Refer to document DP-1145 for more details.

6.2 Data Link Library

A DLL can also be used for volume production. It contains the necessary functions to allow the automatic test equipment to configure the OSDI modules according to the configuration file generated by Trilliant.

7 Regulatory Agency Approvals

Modular approval allows end users to place the OSDI module inside a finished product without the need for regulatory testing, provided no changes or modifications are made to the module circuitry. Changes or modifications could void the user's authority to operate the equipment. The end user must comply with all of the instructions provided by the grantee, which indicate installation and/or operating conditions necessary for compliance.

The OSDI Module has been tested and conforms to FCC and IC regulation for unlicensed transmitter module. The module tests can be applied toward final product certification. Additional testing may be required depending on the targeted application.

The integrator may still be responsible for testing the end product for any additional compliance requirements that become necessary.

For more information on regulatory compliance, refer to the specific country radio regulations in the following sections.

7.1 United States

With the approval of Federal Communications Commission (FCC) CFR47 Telecommunications, Part 15 Subpart C-Intentional Radiators 15.212 Modular Transmitter approval, the OSDI module is authorized to be integrated into a finished product without obtaining subsequent and separate FCC approvals for intentional radiation.

The OSDI module is labeled with its own FCC ID number. If the FCC ID is not visible when the module is installed inside another device, then the outside of the finished product into which the module is installed shall display a label referring to the enclosed module. This exterior label shall bear the following statement:

Contains Transmitter Module FCC ID: **TMB-OSDI4W1**
Or
Contains FCC ID: **TMB- OSDI4W1**

This device complies with Part 15 of the FCC Rules. Operation is subject to the following two conditions:

(1) this device may not cause harmful interference, and (2) this device must accept any interference received, including interference that may cause undesired operation.

A user manual for the finish product shall include the following statement:

This equipment has been tested and found to comply with the limits for a Class B digital device, pursuant to part 15 of the FCC Rules. These limits are designed to provide reasonable protection against harmful interference in a residential installation. This equipment generates, uses and can radiate radio frequency energy, and if not installed and used in accordance with the instructions, may cause harmful interference to radio communications. However, there is no guarantee that interference will not occur in a particular installation. If this equipment does cause harmful interference to radio or television reception, which can be determined by turning the equipment off and on, the user is encouraged to try to correct the interference by one or more of the following measures:

- Reorient or relocate the receiving antenna.
- Increase the separation between the equipment and receiver.
- Connect the equipment into an outlet on a circuit different from that to which the receiver is connected.
- Consult the dealer or an experienced radio/TV technician for help.

7.1.1 RF Human Exposure

All transmitters regulated by FCC must comply with RF exposure requirements. Part 1.1310, **Evaluating Compliance with FCC Guidelines for Human Exposure to Radio Frequency Electromagnetic Fields**, provides assistance in determining whether proposed or existing transmitting facilities, operations or devices comply with limits for human exposure to Radio Frequency (RF) fields adopted by the Federal Communications Commission (FCC). The bulletin offers guidelines and suggestions for evaluating compliance.

If appropriate, compliance with exposure guidelines for mobile and unlicensed devices can be accomplished by the use of warning labels and by providing users with information concerning minimum separation distances from transmitting structures and proper installation of antennas.

The following statement must be included as a CAUTION statement in manuals and OEM products to alert users of FCC RF exposure compliance:

To satisfy FCC RF Exposure requirements for mobile and base station transmission devices, a separation distance of 20 cm or more should be maintained between the antenna of this device and persons during operation. To ensure compliance, operation at closer than this distance is not recommended.

If the OSDI modules are used in a portable application (i.e., the antenna is less than 20 cm from persons during operation), the integrator is responsible for performing Specific Absorption Rate (SAR) testing in accordance with FCC rules 2.1091.

7.1.2 Approved External Antenna Types

To maintain modular approval in the United States, only the antenna types that have been tested shall be used. It is permissible to use different antenna manufacturer provided the same antenna type and antenna gain (equal to or less than) is used. Also, the antenna(s) used for this transmitter must not be co-located or operating in conjunction with any other antenna or transmitter.

Testing of the OSDI module has been performed with the antenna types listed in Section 4.3 above.

7.1.3 Helpful Web Sites

Federal Communications Commission (FCC):

<http://www.fcc.gov>.

7.2 Canada

The OSDI module targets certification for use in Canada under Industry Canada (IC) Radio Standards Specification (RSS) RSS-247 and RSS-Gen. Modular approval permits the installation of a module in a host device without the need to recertify the device.

Labeling Requirements for the Host Device (from Section 7.2, RSP-100, Issue 10, November 2014):

The host device shall be properly labeled to identify the module within the host device.

The Industry Canada certification label of a module shall be clearly visible at all times when installed in the host device, otherwise the host device must be labeled to display the Industry Canada certification number of the module, preceded by the words "Contains transmitter module", or the word "Contains", or similar wording expressing the same meaning, as follows:

Contains transmitter module IC: **6028A-OSDI4W1**
Or
Contains IC: **6028A-OSDI4W1**

User Manual Notice for License-Exempt Radio Apparatus (from Section 8.4 RSS-Gen, Issue 4, November 2014):

User manuals for license-exempt radio apparatus shall contain the following or equivalent notice in a conspicuous location in the user manual or alternatively on the device or both:

This device complies with Industry Canada license-exempt RSS standard(s). Operation is subject to the following two conditions: (1) this device may not cause interference, and (2) this device must accept any interference, including interference that may cause undesired operation of the device.

Le présent appareil est conforme aux CNR d'Industrie Canada applicables aux appareils radio exempts de licence. L'exploitation est autorisée aux deux conditions suivantes: (1) l'appareil ne doit pas produire de brouillage, et (2) l'utilisateur de l'appareil doit accepter tout brouillage radioélectrique subi, même si le brouillage est susceptible d'en compromettre le fonctionnement.

7.2.1 RF Human Exposure

All transmitters regulated by Industry Canada must comply with RF exposure requirements. RSS-102, **Radio Frequency (RF) Exposure Compliance of Radiocommunication Apparatus (All Frequency Bands)**, sets out the requirements and measurement techniques used to evaluate radio frequency (RF) exposure compliance of radiocommunication apparatus designed to be used within the vicinity of the human body.

If appropriate, compliance with exposure requirements for mobile and unlicensed devices can be accomplished by the use of warning labels and by providing users with information concerning minimum separation distances from transmitting structures and proper installation of antennas.

The following statement must be included as a CAUTION statement in manuals of OEM products to alert users of Industry Canada RF exposure compliance:

To satisfy Industry Canada RF Exposure requirements for mobile and base station transmission devices, a separation distance of 20 cm or more should be maintained between the antenna of this device and persons during operation. To ensure compliance, operation at closer than this distance is not recommended.

Pour satisfaire les requis d'industrie Canada sur les expositions aux radiofréquences pour les appareils mobiles et les stations de transmission, une distance de 20 cm ou plus doit être maintenue entre l'antenne de cet appareil et les personnes durant l'opération. Pour assurer la conformité, les opérations à des distances inférieures ne sont pas recommandées.

If the OSDI modules are used in a portable application (i.e., the antenna is less than 20 cm from persons during operation), the integrator is responsible for performing Specific Absorption Rate (SAR) testing in accordance with Industry Canada RSS-102.

7.2.2 Approved External Antenna Types

The OSDI modules may operate with different types of antennas. However, it is not permissible to exceed the maximum equivalent isotropically radiated power (e.i.r.p.) limits specified in the applicable standard (RSS) for the licence-exempt apparatus.

Testing shall be performed using the highest gain antenna of each combination of transmitter and antenna type, with the transmitter output power set at the maximum level. When a measurement at the antenna connector is used to determine RF output power, the effective gain of the device's antenna shall be stated, based on measurement or on data from the antenna manufacturer. User manuals for transmitters equipped with detachable antennas shall also contain the following notice in a conspicuous location:

This radio transmitter TMB-OSDI4W1 has been approved by Industry Canada to operate with the antenna types listed below with the maximum permissible gain indicated. Antenna types not included in this list, having a gain greater than the maximum gain indicated for that type, are strictly prohibited for use with this device.

Le présent émetteur radio TMB-OSDI4W1 a été approuvé par Industrie Canada pour fonctionner avec les types d'antenne énumérés ci-dessous et ayant un gain admissible maximal. Les types d'antenne non inclus dans cette liste, et dont le gain est supérieur au gain maximal indiqué, sont strictement interdits pour l'exploitation de l'émetteur.

Immediately following the above notice, the manufacturer shall provide a list of all antenna types approved for use with the transmitter, indicating the maximum permissible antenna gain (in dBi).

The antenna(s) used for this transmitter must not be co-located or operating in conjunction with any other antenna or transmitter.

Projected approved external antenna types for the OSDI modules are listed in Section 4.3 above.

7.2.3 Helpful Web Sites

Industry Canada: <http://www.ic.gc.ca/>