

JINOOU Bluetooth Serial Adapter (Class 2) Manual

1. BRIEF INTRODUCTION:.....	1
2. FEATURES.....	2
3. PROTOCOL REALIZED	2
4. INDICATOR LIGHT AND PRESS BUTTON	3
5. HOW TO SET UP INITIAL PARAMETER	3
6. LEG DEMONSTRATION.....	4
7. USAGE.....	5

1. Brief introduction

Bluetooth RS232 adapter can be applied to all kinds of home appliances, equipment (such as medical treatment equipment) and other electronic information products. As a cable replacement program, it can connect the single-chip processor or processor directly via using PnP mode to achieve the wireless data transmission among equipments transparently. Bluetooth RS232 adapter has the discrimination of principal and subordinate, which can be matched as one set. The principal and subordinate equipment can establish connection, identify and memorize the opposite equipments automatically when hardware circuit of Bluetooth RS232 adapter connects correctly with electricity supply. The equipments of user can use RS232 Bluetooth adapter as the same as serial wires.

Bluetooth RS232 adapter can be used independently as well, excluding using by match. When user's equipment equipped with a RS232 Bluetooth adapter of one subordinate equipment, other Bluetooth devices, such as Bluetooth PDA can search out adapter of this RS232, and find out the services provided, then establish links and communication with this adapter through these services as well. This module can still be used as the same as the serial wires for the communications of users' equipments.

RS232 Bluetooth adapter provides a safety identification function. When users use safety identification, the equipments' connects must be authenticated, and only the authenticated equipment can realize communication. However this process could be automatically finished among a matched Bluetooth adapter (acquiescence code: 1234).

In figure 1, users' equipments between A and B connect by a serial wire; as shown in Figure 2, users' equipments between A and B connect by Bluetooth RS232 adapters. For equipments of users, these two types could be considered to be connected with a serial wire. Figure 3 shows the connecting situation between Bluetooth RS232 adapter and other Bluetooth equipment (shown here is the Bluetooth PDA). Under such circumstances, for the user's equipment, it is still the same as indicated in Figure 1 and Figure 2_just like to be connected with a serial line..

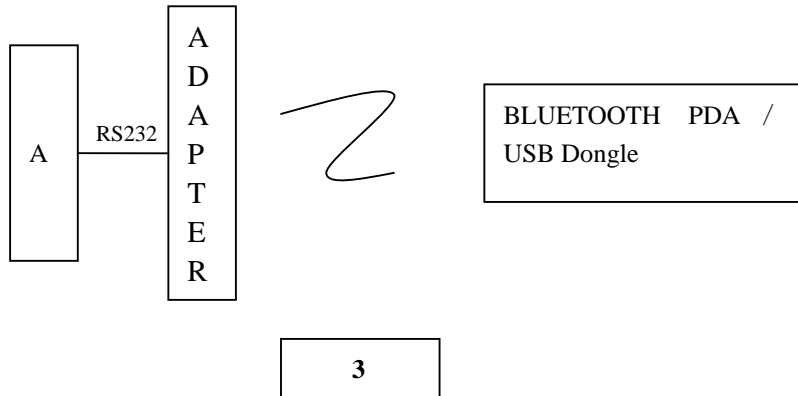
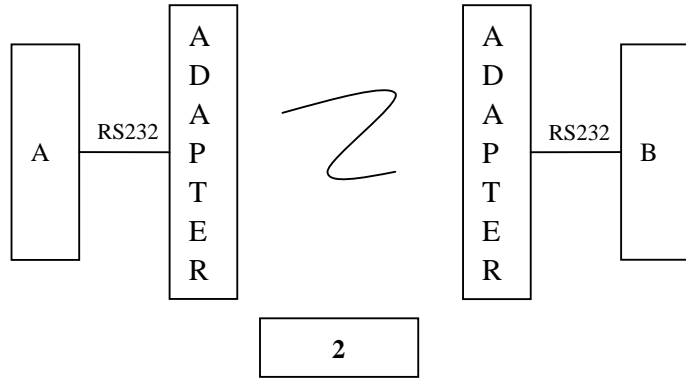
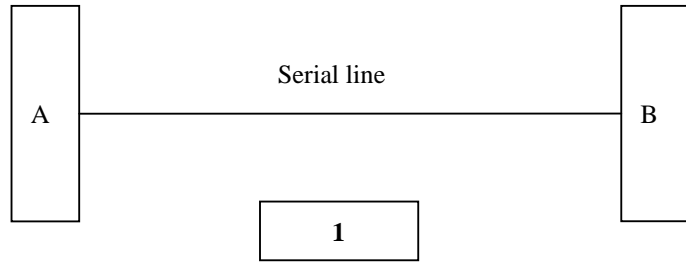

2. Features

- Compatible Bluetooth 1.1 Specification
- Class 1 Standard
- Effective distance 100M
- Standard RS232 (DTE) Interface
- Multiple Baud Rates are supported (9.6k and 19.2k, 38.4k and 57.6k, 115.2k)
- Automatic energy-saving mode
- Low -power -wasted mode support & high-speed working mode support

3. Protocols Realized

- LM、LC、L2cap、SDP、RFCOMM

Realize Bluetooth Serial Protocol (Bluetooth Serial Port Profile)

4. Indicator light and press button

Link light is applied in RS232 Adapter to indicate the working state and the cmd data switch is used to change the working mode (data mode or command mode).

LINK lights: If LINK light twinkles one time every five seconds, links with other Bluetooth equipment should be finished; if it twinkles one time or even faster every two seconds, it renders no links have been established. When there is no established link, through LINK lights flashing speed, we can determine whether the equipment has memorized address or not, that is to say, we can determine weather it is adaptable for other Bluetooth equipment or not, if it twinkles fast (2 twinkles per second), it has memorized address; if it twinkle slowly (1 twinkle per second), it means no memory about addresses exists. For the principal equipment, it is normal that 2 twinkles per seconds while consulting, 4 fast twinkles per second while matching, single twinkle per second while linking, one twinkle per 5 seconds after connecting.

The LINK light extinguish while the RS232 is in the state of parameter setting.

Cmd Data Switch: while moving Cmd Data Switch to the Cmd side, RS232 adapter indicator light is extinguished, the RS232 adapter is working in the state of parameters setting. RS232 adapter stops working in the parameters' setting state, you can install only RS232 adapter parameters at this time. While moving Cmd Data to the Data side, RS232 adapter quits the state of parameters setting, and begins to work (search, match, link, transfer data, etc.) this time, but you can not install parameters of the RS232 adapter. If users need to install parameters, please move Cmd Data Switch to the Cmd side, if not, please keep the Cmd Data Data Switch on the Data side.

Hereunder attached the chart about indicator lights and button:

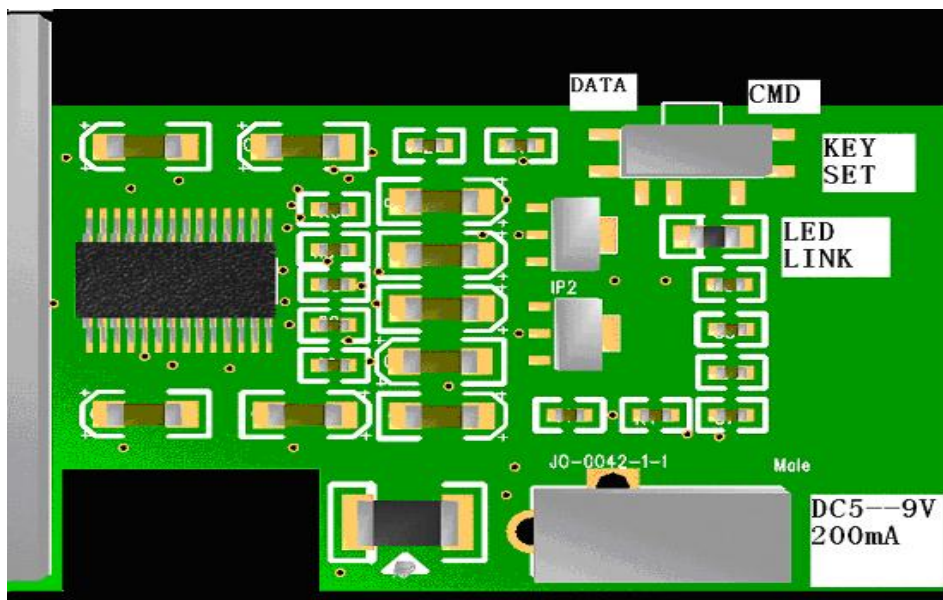

5. How to Set up Initial Parameter

RS232 adapter's parameters are initially installed as subordinate equipment with 115,200 baud rate, and matching passwords 1234 (which should be searched and

matched by other Bluetooth equipment). It can be revised to suitable value according to different situations.

6. LEG DEMONSTRATION

1) LEG Demonstration

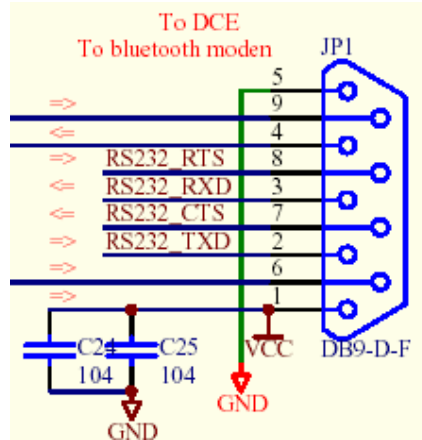

As you can see from this picture, it is RS232 serial adapter, leg 1 is the power, leg five is the stuff connecting earth. Usual voltage keeps 4.9V, and TTL signal keeps 5V.

When the module keeps the condition of being not connecting, leg 9 outputs lower electricity. And it can reach to above 5V when it connects. Please let the leg 6 which is a leg of cancel address connects low voltage usually. If you want to cancel address and fit again, you should give it a high voltage.

2) Specification for Dongle

The module process edition number is 2.7. if you want to set the parameter, please use the edition of 2.x set tool. And the specific using way you can find it in 2.x edition using demonstration of set tool. You also should make the module connecting to computer, and connect plug.

Module acquiescence parameter:

Usual voltage: 5v to 14v
input or output signal voltage: +/-5v
bond rate : 38,400
Machine name RxBt01
Relationship: be subordinate to machine
Identity right: no
Corded or not: no

leg definition followed:

Pin1
Pin2 TxD
Pin3 RxD
Pin4 NC
Pin5 GND

Pin6
Pin7 CTS
Pin8 RTS
Pin9 VCC

Notes: Pin9 is plug (power)
Pin5 connects earth

When the module keeps the condition of being not connecting, pin1 outputs lower electricity. Outputs high voltage after connects successfully.

Pin 6 is canceling address function.

7. Usage

If amendment of the parameters are needed, please move Cmd Data Switch to Cmd side until the completion of parameter setting, and install related parameters via the "AT command" or "parameter setting tool", such as parameters for principle/subordinate equipment, baud rate, authentication and address binding. If the communication is between two RS232 adapters, you should make an equipment the principle one, and another one subordinate. Please move the Cmd Data to the Date side after finished.

After starting the equipment up, if no memorized addresses are saved, search nearby Bluetooth equipment first. If searching out, the principle equipment would enter into matching state. If authenticating right, the principle equipment would memorize (save) the address, and establish links with the equipment. If linking success, LINK light twinkles one time every five seconds; if having memorized addresses yet, the principle equipment connects directly with the memorized equipment without inquiries and matching. The memorized address could be deleted by using the AT command and parameters setting tool.

As for subordinate equipment, which wait for being connected and searched by other equipment, its LINK light twinkles every five seconds, if connecting successfully.

FCC Statement:

This device complies with Part 15 of the FCC Rules. Operation is subject to the following two conditions:

- (1) This device may not cause harmful interference, and
- (2) This device must accept any interference received, including interference that may cause undesired operation.

This equipment has been tested and found to comply with the limits for a Class B digital device, pursuant to part 15 of the FCC Rules. These limits are designed to provide reasonable protection against harmful interference in a residential installation. This equipment generates, uses, and can radiate radio frequency energy and, if not installed and used in accordance with the instructions, may cause harmful interference to radio communication. However, there is no guarantee that interference will not

occur in a particular installation. If this equipment does cause harmful interference to radio or television reception, which can be determined by turning the equipment off and on, the user is encouraged to try to correct the interference by one or more of the following measures:

- Reorient or relocate the receiving antenna.
- Increase the separation between the equipment and receiver.
- Connect the equipment into an outlet on a circuit different from that to which the receiver is connected.
- Consult the dealer or an experienced radio/TV technician for help.

Modifications not authorized by the manufacturer may void user's authority to operate this device.