

# Trimble TVG-850 68008-XX-IM Installation Instructions

Revision: 02

Jun 16, 2010



© Copyright 2009, Trimble Navigation Limited. All rights reserved.

The Sextant Logo with Trimble, the Globe & Triangle logo with Trimble, Telvisant, IQEvent Engine, CrossCheck, TVG-850 and iDT are trademarks of Trimble Navigation Limited registered in the United States Patent and Trademark Office.

TrimFleet, TrimWeb, TrimView, and TrimTrac are trademarks of Trimble Navigation Limited.

All other trademarks are the property of their respective owners.

Trimble Navigation Limited  
935 Stewart Drive  
Sunnyvale, California 94085  
Phone: (408) 481-8000

[www.trimble.com](http://www.trimble.com)

### **Software License, Limited Warranty**

This Trimble software product, whether provided as a stand-alone computer software product, built into hardware circuitry as firmware, embedded in flash memory, or stored on magnetic or other media, (the "Software") is licensed and not sold, and its use is governed by the terms of the relevant End User License Agreement ("EULA") included with the Software. In the absence of a separate EULA included with the Software providing different limited warranty terms, exclusions and limitations, the following terms and conditions shall apply. Trimble warrants that this Trimble Software product will substantially conform to Trimble's applicable published specifications for the Software for a period of ninety (90) days, starting from the date of delivery.

### **Warranty Remedies**

Trimble's sole liability and your exclusive remedy under the warranties set forth above shall be, at Trimble's option, to repair or replace any Product or Software that fails to conform to such warranty ("Nonconforming Product") or refund the purchase price paid by you for any such Nonconforming Product, upon your return of any Nonconforming Product to Trimble in accordance with Trimble's standard return material authorization procedures.

### **Warranty Exclusions and Disclaimer**

These warranties shall be applied only in the event and to the extent that the Products and Software are (i) properly and correctly installed, configured, interfaced, maintained, stored, and operated in accordance with Trimble's relevant operator's manual and specifications, and; (ii) the Products and Software are not modified or misused. The preceding warranties shall not apply to, and Trimble shall not be responsible for defects or performance problems resulting from (i) the combination or utilization of the Product or Software with hardware or software products, information, data, systems, interfacing or devices not made, supplied or specified by Trimble; (ii) the operation of the Product or Software under any specification other than, or in addition to, Trimble's standard specifications for its products; (iii) the unauthorized modification or use of the Product or Software; (iv) damage caused by accident, lightning or other electrical discharge, fresh or salt water immersion or spray; or (v) normal wear and tear on consumable parts (e.g., batteries). Trimble does not warrant or guarantee the results obtained through the use of the Product.

THE WARRANTIES ABOVE STATE TRIMBLE'S ENTIRE LIABILITY, AND YOUR EXCLUSIVE REMEDIES, RELATING TO PERFORMANCE OF THE PRODUCTS AND SOFTWARE. EXCEPT AS OTHERWISE EXPRESSLY PROVIDED HEREIN, THE PRODUCTS, SOFTWARE, AND ACCOMPANYING DOCUMENTATION AND MATERIALS ARE PROVIDED "AS-IS" AND WITHOUT EXPRESS OR IMPLIED WARRANTY OF ANY KIND BY EITHER TRIMBLE NAVIGATION LIMITED OR ANYONE WHO HAS BEEN INVOLVED IN ITS CREATION, PRODUCTION, INSTALLATION, OR DISTRIBUTION INCLUDING, BUT NOT LIMITED TO, THE IMPLIED WARRANTIES OF MERCHANTABILITY AND FITNESS FOR A PARTICULAR PURPOSE, TITLE, AND NONINFRINGEMENT. THE STATED EXPRESS WARRANTIES ARE IN LIEU OF ALL OBLIGATIONS OR LIABILITIES ON THE PART OF TRIMBLE ARISING OUT OF, OR IN CONNECTION WITH, ANY PRODUCTS OR SOFTWARE. SOME STATES AND JURISDICTIONS DO NOT ALLOW LIMITATIONS ON DURATION OR THE EXCLUSION OF AN IMPLIED WARRANTY, SO THE ABOVE LIMITATION MAY NOT APPLY TO YOU.

TRIMBLE NAVIGATION LIMITED IS NOT RESPONSIBLE FOR THE OPERATION OR FAILURE OF OPERATION OF GPS SATELLITES OR THE AVAILABILITY OF GPS SATELLITE SIGNALS.

### **Limitation of Liability**

TRIMBLE'S ENTIRE LIABILITY UNDER ANY PROVISION HEREIN SHALL BE LIMITED TO THE AMOUNT PAID BY YOU FOR THE PRODUCT OR SOFTWARE LICENSE. TO THE MAXIMUM EXTENT PERMITTED BY APPLICABLE LAW, IN NO EVENT SHALL TRIMBLE OR ITS SUPPLIERS BE LIABLE FOR ANY INDIRECT, SPECIAL, INCIDENTAL OR CONSEQUENTIAL DAMAGES WHATSOEVER UNDER ANY CIRCUMSTANCE OR LEGAL THEORY RELATING IN ANY WAY TO THE PRODUCTS, SOFTWARE AND ACCOMPANYING DOCUMENTATION AND MATERIALS, (INCLUDING, WITHOUT LIMITATION, DAMAGES FOR LOSS OF BUSINESS PROFITS, BUSINESS INTERRUPTION, LOSS OF BUSINESS INFORMATION, OR ANY OTHER PECUNIARY LOSS), REGARDLESS WHETHER TRIMBLE HAS BEEN ADVISED OF THE POSSIBILITY OF ANY SUCH LOSS AND REGARDLESS OF THE COURSE OF DEALING WHICH DEVELOPS OR HAS DEVELOPED BETWEEN YOU AND TRIMBLE. BECAUSE SOME STATES AND JURISDICTIONS DO NOT ALLOW THE EXCLUSION OR LIMITATION OF LIABILITY FOR CONSEQUENTIAL OR INCIDENTAL DAMAGES, THE ABOVE LIMITATION MAY NOT APPLY TO YOU.

NOT WITHSTANDING THE ABOVE, IF YOU PURCHASED THIS PRODUCT OR SOFTWARE IN THE EUROPEAN UNION, THE ABOVE WARRANTY PROVISIONS MAY NOT APPLY. PLEASE CONTACT YOUR DEALER FOR APPLICABLE WARRANTY INFORMATION.

## **FCC Compliance Statement:**

This device complies with Part 15 of the FCC Rules. Operation is subjected to the following two conditions:

- (1) this device may not cause harmful interference, and
- (2) this device must accept any interference received, including interference that may cause undesired operation.

## **FCC WARNING**

Note: This equipment has been tested and found to comply with the limits for a Class B digital device, pursuant to part 15 of the FCC Rules. These limits are designed to provide reasonable protection against harmful interference in a residential installation. This equipment generates, uses, and can radiate radio frequency energy and, if not installed and used in accordance with the instructions, may cause harmful interference to radio communications. However, there is no guarantee that interference will not occur in a particular installation. If this equipment does cause harmful interference to radio or television reception, which can be determined by turning the equipment off and on, the user is encouraged to try to correct the interference by one or more of the following measures:

- Reorient or relocate the receiving antenna.
- Increase the separation between the equipment and receiver.
- Connect the equipment into an outlet on a circuit different from that to which the receiver is connected.
- Consult the dealer or an experienced radio/TV technician for help.

Modifications not expressly approved by the manufacturer could void the user's authority to operate the equipment under FCC rules.

## Table of Contents

1. DESCRIPTION .....	1
2. PRODUCT OVERVIEW .....	1
3. EXTERNAL DOCUMENTATION .....	1
4. MECHANICAL SPECIFICATION .....	2
5. PARTS LIST.....	3
6. TOOLS AND ITEMS REQUIRED FOR INSTALLATION .....	4
7. MOUNTING THE TVG-850 .....	5
8. WIRING THE TVG-850 .....	6
9. ANTENNA INSTALLATION .....	9
10. FUNCTIONAL CHECKOUT .....	11
LOCATING THE R-TERMINAL.....	13

## **1. DESCRIPTION**

This document contains hardware installation instructions for the Trimble 68008-XX. For information on product configuration, refer to document 68008-XX-UM Users Manual.

## **2. PRODUCT OVERVIEW**

The TVG-850 is a telematics device with a incorporating a heavy-duty power supply designed to operate on both 12V and 24V systems, a 12-channel GPS receiver, long-range wireless communication modems, an optional 802.11b/g modem, an optional Bluetooth modem, two RS-232 serial ports operating up to 115kbaud with 12V power on pin 9, five digital inputs, two digital outputs, ignition and R-terminal sense and a vehicle information bus interface that supports OBD-II, J1939, and J1708.

ILM6000 performs data collection from the vehicle and other sensors, processes the data and then sends the data wirelessly to a central data server using various wireless technologies.

## **3. EXTERNAL DOCUMENTATION**

68008-XX-UM – Users Manual

68008-XX-IM – Installation Manual

## 4. MECHANICAL SPECIFICATION

### 4.1. Mechanical Drawing

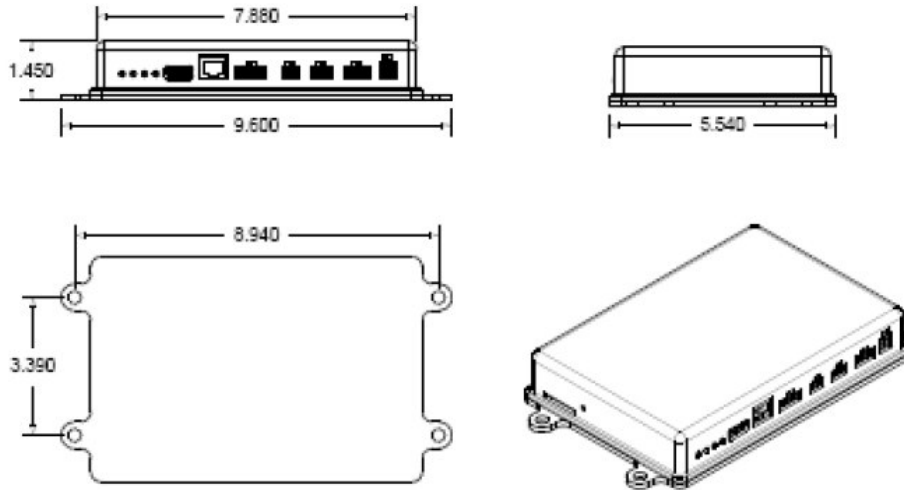

### 4.2. Mechanical Description

The enclosure is made of a rugged cast aluminum enclosure with a powder coat finish. It provides four mounting holes that accept 1/4-20 screws for secure mounting.

### 4.3. Dimensions

Item	Typical	Unit
External dimensions without mounting tabs (W x L x H)	8.91X0.94X4.33	in.
Weight	TBD	lbs.
Mounting Bolt Pattern	2.5X8.56	in.

## 5. PARTS LIST

Description	Trimble Part Number	Quantity
Mobile Data Unit – TVG-850 EVDO	68008-10	1
Mobile Data Unit – TVG-850 HSPA	68008-20/30/40	
Combination Antenna Option 1: WAN and GPS	901-1005-000	*
Combination Antenna Option 2: WAN, GPS and WLAN	TBD	*
Power Harness Cable Kit	68207-00	*
Power Harness	68207	1
Inline ATO Fuse Holder 16 AWG	59859	2
1 Amp Fast-Acting Automotive ATO Fuse	59860	1
7.5 Amp Fast-Acting Automotive ATO Fuse	68038	1
Serial 1	907-1028-000	*
Serial 2	80083	*
Digital I/O Harness (Optional)	950-0015-010	*
Light Vehicle, Veh-Bus Harness (Optional)	79817	*
OBD-II Y Cable (Optional)	TBD	*
Heavy Vehicle, Vehicle Bus Harness (Optional)	TBD	*

*\*Antennas, power harnesses and I/O harnesses are not included with standard kit, but are available as separate accessories from Trimble.*

## 6. TOOLS AND ITEMS REQUIRED FOR INSTALLATION

The following tools and hardware are not supplied but may be required for installation of the TVG-850:

- Wire cutters and strippers
- Digital multi-meter
- P2 Phillips screwdriver
- Crimp tool for insulated barrel type connectors
- Solderless 18-22 AWG barrel type butt connectors
- Solderless 14-16 AWG barrel type butt connectors
- Solderless #10-5/16" 18-22 AWG ring terminals
- ¼-20X1" nuts and bolts with suitable washers (Stainless steel is preferred)
- #8X1/2" Self drilling screw
- Tie Wraps
- Dielectric Grease
- 6" Diameter ground plane. Trimble Part Number 55399



## 7. MOUNTING THE TVG-850

**CAUTION:** Before drilling or cutting through any part of the vehicle, it is the installer's responsibility to make certain that there is adequate clearance behind the surface to be drilled and confirm that no wiring, fuel, brake lines, hydraulic lines, interior parts, or other objects could potentially be damaged during installation. You must also consider the possibility of water ingress into sensitive areas of vehicle such as into the cab enclosure, or near vehicle's sensitive electrical equipment.

**CAUTION:** Never drill or cut through structural elements of equipment such as frame, roll cages etc.

Mount the unit to the vehicle using four 1/4-20 X 1" mounting bolts and nuts with nylon locking inserts. The following important guidelines *must* be followed when mounting the unit in the vehicle.

1. The TVG-850 must be mounted inside the passenger compartment of the vehicle. Any areas subject to extreme heat or vibration should be avoided as should mounting areas that may expose the unit to contact with petroleum products, corrosive materials or other chemicals and solvents.
2. Be sure to select a mounting location that permits convenient routing of antenna, serial, display, power and vehicle bus cables. When available, under-seat, rear wall of cab, or in-dash mounting may often be the best option. It is the installer's responsibility to carefully evaluate each installation to determine the best mounting option.
3. The unit must be mounted as securely as possible to avoid vibration or position shift.

## 8. WIRING THE TVG-850

### 8.1. Power Connector Pin Descriptions

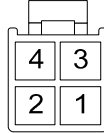

CONNECTOR  
REAR VIEW

Description	Wire Color	Pin No.	Abbr.
Battery Positive	Red	1	V <sub>BATT+</sub>
Ground	Black	2	V <sub>BATT-</sub>
Ignition	White	3	IGN
Digital Input 5* (SINE input)	Pink	4	DIG5_IN

Table 1

### 8.2. Ignition Input

The TVG-850 has an ignition sense input which senses an active high signal. This input can be used to monitor the vehicle's ignition circuit. If the customer wishes to collect runtime hours based on actual engine run time rather than ignition on time, this input should be left unconnected and Pin 4 DIG5\_IN may be used to sense voltage on the R-Terminal of the vehicle's alternator (For additional information; see Section 11 "LOCATING THE R-TERMINAL")

### 8.3. Digital I/O Pin Description

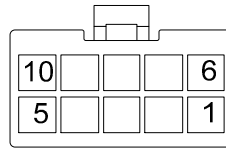

CONNECTOR REAR VIEW

Description	Harness Wire Colors	Connector Pin No.
DIGITAL INPUT 1	TAN	1
DIGITAL INPUT 2	TAN/WHITE	2
DIGITAL INPUT 3	PINK	3
DIGITAL INPUT 4	PINK/WHITE	4
RELAY 1 CONTROL	GREEN/WHITE	5
RELAY 2 CONTROL	GREEN/YELLOW	6
12V RELAY	RED/WHITE	7
12V RELAY	RED/YELLOW	8
12V SENSOR POWER	RED/BLACK	9
12V SENSOR GROUND	BLACK/WHITE	10

Table 2

### 8.4. Digital Inputs

The TVG-850 has 5 general purpose digital inputs. The purpose of these inputs is to provide interfaces to switches and sensors mounted on the vehicle. When the unit is in hibernation mode the state of the inputs sampled at a regular interval. Digital Input 5 has a zero crossing detector for analog (sine wave) input signals. Digital inputs 1 to 4 may be configured to sense active high or active low inputs. For electrical and timing specifications see Recommended DC Electrical Specifications and Recommended AC Electrical Specifications. For connector pin description see Digital I/O Pin Description.

### 8.5. Digital Outputs

The TVG-850 has two general purpose outputs which can sink up to TBDmA of current. For connector pin description see Digital I/O Pin Description.

## 8.6. Power Connections

- 1) Connect Pin 2 of the power harness (Black) to vehicle's chassis using a self-drilling screw and a crimp-on # 10 ring terminal. Make sure that a good electrical connection is made to the chassis. It may be necessary to remove the finish to expose the bare metal of the vehicle's chassis.

**NOTE:** For proper function, the TVG-850 requires connection of **EITHER** Ignition or R-Terminal. **Under no circumstances should BOTH Ignition and R-Terminal be connected.**

- 2) If monitoring Ignition; connect Pin 1 (White) of the power harness to the vehicle's ignition circuit. The ignition circuit must change electrical state from Low (less than 1 Volt) to High (more than 3 Volts) when ignition key is moved to the ON position.
- 3) If monitoring engine run-time hours; connect Pin 4 (Pink) of the power harness to the R-Terminal of the vehicle's alternator. See Section 11 for details.+
- 4) Using the supplied inline fuse holder and 7.5A fuse, connect power harness Pin 1 (Red) to a point in the vehicle that provides continuous (not switched) battery power. The provided fuse holder and 7.5 amp blade fuse should be installed in-line as close to the power source as practical.

## 8.7. Vehicle Information Bus Interface

The iLM vehicle bus interface may be connected to heavy-duty or light duty vehicles via the optional HDV or LDV vehicle bus cables. The specific interfaces are OBD-II, J1708 and J1939. This allows the unit to listen and poll for vehicle bus messages. Full functionality of this interface is described in the TBD-XX-UM document. For connector pin description see Digital I/O Pin Description.

## 9. ANTENNA INSTALLATION

### 9.1. INSTALLATION GUIDELINES

The standard Multi-band surface mount antenna is supplied with two cables, one for GPS and the other for the wireless modem. There is a Wi-Fi option available which uses a third cable for the 2.4GHz range. Each cable is 15" (4.5m) long and equipped with separate, unique connectors to assure that each antenna cables is properly connected to the TVG-850. The Cable connector scheme follows:

- The wireless modem antenna cable (RF-195) has a FAKRA D (Violet) connector.
- The Wi-Fi modem antenna cable uses a FAKRA A (Black) connector.
- The GPS antenna cable (RG-174) has a FAKRA C (Blue) connector.
- The optional Bluetooth antenna if equipped uses RG-174 cable with a FAKRA A (Black) connector.

**NOTE:** *The Quad-band surface mount antenna is **ground plane dependent** and therefore should be mounted on a metal surface. If a metal surface is not available, the antenna may be mounted on a fiberglass surface provided an appropriate ground plane is used. Trimble has a 6" diameter ground plane disc (p/n 55399) for fiberglass surfaces. This item must be ordered separately.*

### 9.2. CHOOSING A LOCATION FOR THE ANTENNA

When choosing a location for the Quad-band antenna, make sure that:

- the antenna will be mounted on a flat surface metal surface (i.e. roof)
- The surface is clean enough to ensure proper sealing. All dust that settles on it must be removed
- Antenna must have an unobstructed view of the sky and as much of the horizon as possible
- If the antenna must be located in the vicinity of other antennas (radio, etc), locate the Tri-band antenna at least 46cm (approximately 18 in.) away from the other antennas.

**Note:** *The antenna cannot be located directly above or beside any device (i.e. 2-Way Radio, CB Radio mounted in headliner console) that might cause frequency interference.*

- Avoid areas of high vibration such as engine hoods.
- The chosen location provides access both above and below the antenna-mounting surface. This access is required to secure the antenna mounting and for routing the antenna cable.
- Before drilling, make sure the combined length of the antenna cable and extension cable will reach the GPS receiver from the intended antenna mounting location.
- Drill a 3/4" hole at the mounting location.

**CAUTION:** Before drilling the mounting hole, check the metal thickness at the mounting location. The bulkhead mount on the antenna can be attached to metal surfaces with a thickness of ¼” or less.

- Remove the large nut from the bottom of the antenna
- Feed the coaxial cables through the hole and ground plane disc if present.
- Seat the antenna on the surface and secure it using the large nut.

**Note:** The attached gasket on the base of the antenna provides a seal to prevent moisture from entering the vehicle.

- The nut must be tight in order to properly seal the gasket. Tighten the nut from the bottom with a wrench. **Do not rotate the antenna body from the top** as this will damage the gasket.

**Note:** Manufacturer specifies **3-5 ft-lbs** on nut. Insufficient torque will fail to seal the base while excessive torque will distort base causing eventual antenna failure.

- Route the cables to the TVG-850 securing as necessary with tie wraps. Safely bundle and store any excess cable out of the way being careful not to kink them. You must ensure that the cable will not be damaged by heat, cuts, abrasion, or crush and pinch hazards.
- Connect the cable to the appropriate antenna connectors on the TVG-850.

Drawing to be placed here

**Figure 2 – Typical Antenna Installation**

## 10. FUNCTIONAL CHECKOUT

**NOTE:** The vehicle's ignition must be ON for full operation of the device.

### 10.1. GPS Functional Check

- Start the vehicle and check the LED indicators for status.
- Check the amber LED for the GPS status as indicated in the table below.

<b>LED 1 (bi-color) State</b>	<b>Function</b>
Green blinking	
Green steady on	
Red Blinking	
Red steady on	

<b>LED 2 State</b>	<b>Function</b>
Off	
Slow blink	
Fast Blink	
Steady on	

<b>LED 3 State</b>	<b>Function</b>
Off	
Slow blink	
Fast Blink	
Steady on	

<b>LED 4 State</b>	<b>Function</b>
Off	
Slow blink	
Fast Blink	
Steady on	

### Checking Network Connectivity

- Check the green LED for the network status as indicated by the table below.

## **10.2. Checking For Proper Functionality Of Ignition Circuit**

## **10.3. Checking Digital Inputs And Outputs**



## LOCATING THE R-TERMINAL

Please note that the location of the R-Terminal differs depending on the alternator used in the vehicle. If you cannot locate the alternator's R-Terminal, please contact [trimble\\_support@trimble.com](mailto:trimble_support@trimble.com)

Below are some examples of different alternators used in heavy vehicles, and the location of the R-Terminal.

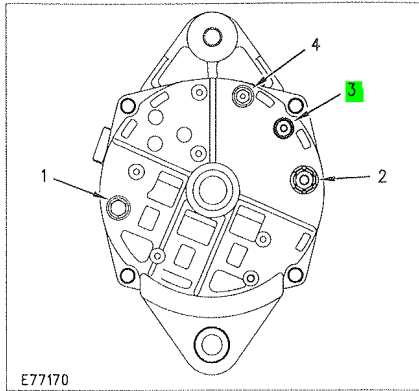

Illustration 3. Delco-Remy 155-7434 Alternator.  
(1) B- terminal. (2) B+ terminal. (3) R terminal.  
(4) Indicator light terminal.

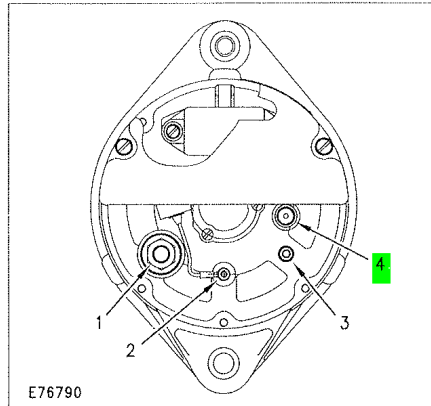

Illustration 1. Bosch 7N-9720, 9G-9538 and 100-5046 Alternators.  
(1) B+ terminal. (2) D+ terminal. (3) B- terminal. (4) R terminal.

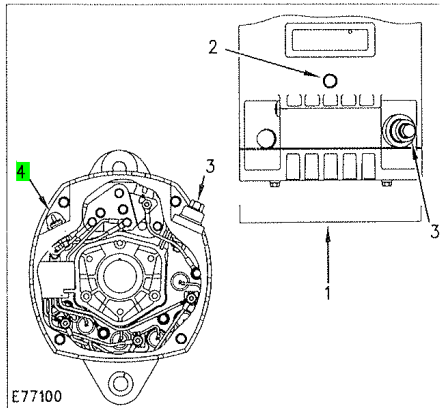

Illustration 4. Delco-Remy 3E-7892, 3E-7578, 3E-7577 and 112-5041 Alternators.  
(1) Top view. (2) B- terminal. (3) B+ terminal. (4) R terminal.

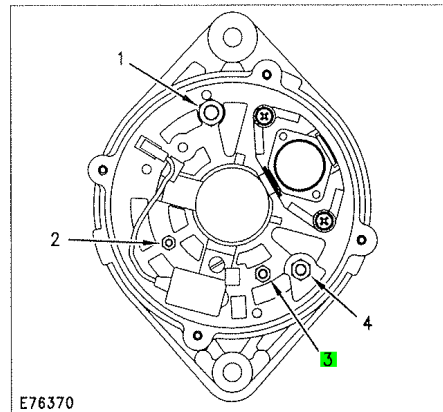

Illustration 2. Bosch 9W-3043 Alternator.  
(1) B+ terminal. (2) D+ terminal. (3) R terminal. (4) B- terminal.

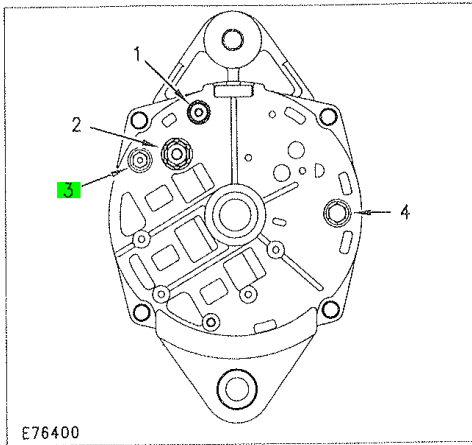

Illustration 7. Delco-Remy 9X-6796, 107-7977, 117-1379, 121-4134, 121-4135, 125-9597 and 132-2156 Alternators.  
 (1) Optional warning light terminal. (2) B+ terminal.  
 (3) R terminal. (4) B- terminal.

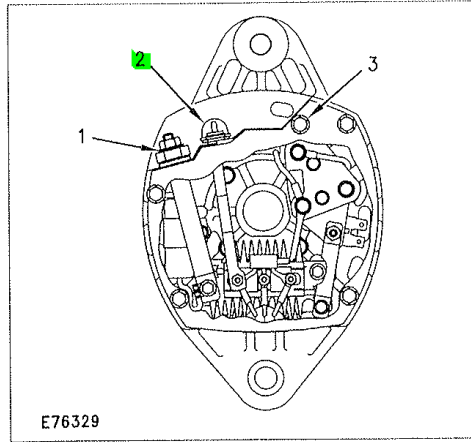

Illustration 6. Delco-Remy 3T-6352, 5N-5692 and 7G-7889 Alternators.  
 (1) B+ terminal. (2) R terminal. (3) B- terminal.

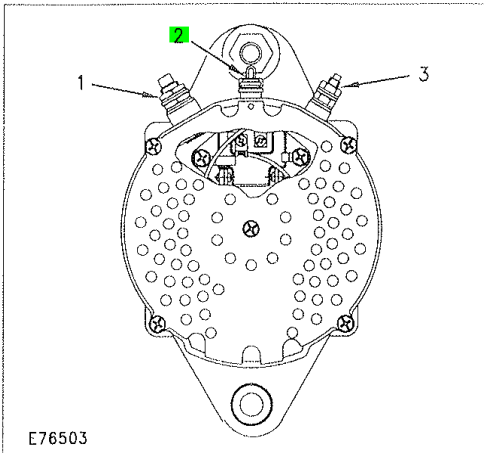

Illustration 9. Denso 9G-4574, 6T-7223 and 100-5045 Alternators.  
 (1) B+ terminal. (2) R terminal. (3) B- terminal.

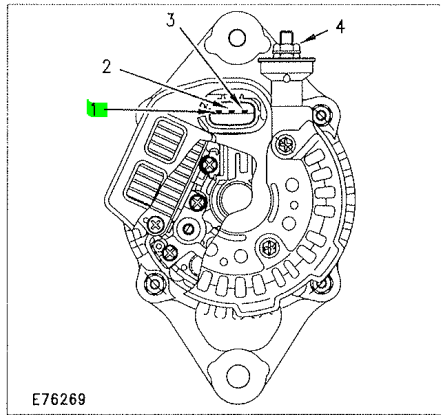

Illustration 10. Denso 3E-7772, 105-2811, 105-2812, 105-2813, 105-2814 and 105-3132 Alternators.  
 (1) R terminal. (2) Ignition. (3) Indicator lamp.  
 (4) B+ terminal.

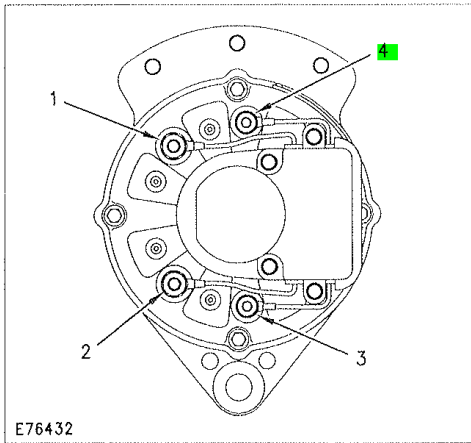

Illustration 12. Motorola/Prestolite 107-2519 and 112-8032 Alternators.  
 (1) B+ terminal. (2) B- terminal. (3, 4) R terminal is an AC tap from the Stator.

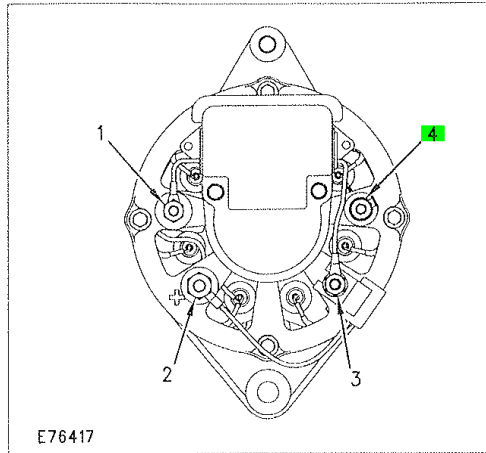

Illustration 13. Motorola/Prestolite 149-2064 Alternator.  
 (1) D+ terminal. (2) B+ terminal. (3) B- terminal. (4) R terminal.

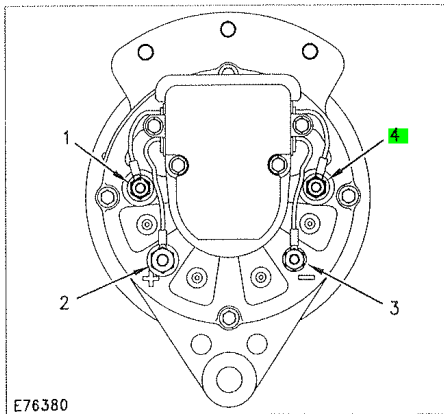

Illustration 14. Motorola/Prestolite 6T-1395, 6T-1396, 7T-2095 and 7T-2096 Alternators.  
 (1, 4) R terminal is an AC tap from the Stator. (2) B+ terminal. (3) B- terminal.