

User Manual E Series Data Radio

ER450 Remote Data Radio
EB450 Base Station
EH450 Hot Stand-by Base Station

wireless communications
wireless



TRIO

DATA COM

ISSUE	CHANGE DETAILS	ECO No	DRAWN	DATE	ISSUE	CHANGE DETAILS	ECO No
-------	----------------	--------	-------	------	-------	----------------	--------

www.trio.com.au

Issue 4: May 2003

Part A – Preface

Warranty

All equipment supplied by Trio DataCom Pty. Ltd. is warranted against faulty workmanship and parts for a period of twelve (12) months from the date of delivery to the customer. During the warranty period Trio DataCom Pty. Ltd. shall, at its option, repair or replace faulty parts or equipment provided the fault has not been caused by misuse, accident, deliberate damage, abnormal atmosphere, liquid immersion or lightning discharge; or where attempts have been made by unauthorised persons to repair or modify the equipment.

The warranty does not cover modifications to software. All equipment for repair under warranty must be returned freight paid to Trio DataCom Pty. Ltd. or to such other place as Trio DataCom Pty. Ltd. shall nominate. Following repair or replacement the equipment shall be returned to the customer freight forward. If it is not possible due to the nature of the equipment for it to be returned to Trio DataCom Pty. Ltd., then such expenses as may be incurred by Trio DataCom Pty. Ltd. in servicing the equipment in situ shall be chargeable to the customer.

When equipment for repair does not qualify for repair or replacement under warranty, repairs shall be performed at the prevailing costs for parts and labour. Under no circumstances shall Trio DataCom Pty. Ltd.'s liability extend beyond the above nor shall Trio DataCom Pty. Ltd., its principals, servants or agents be liable for the consequential damages caused by the failure or malfunction of any equipment.

Important Notice

© Copyright 2002 Trio DataCom Pty. Ltd. All Rights Reserved

This manual covers the operation of the E Series of Digital Data Radios. Specifications described are typical only and are subject to normal manufacturing and service tolerances.

Trio DataCom Pty Ltd reserves the right to modify the equipment, its specification or this manual without prior notice, in the interest of improving performance, reliability or servicing. At the time of publication all data is correct for the operation of the equipment at the voltage and/or temperature referred to. Performance data indicates typical values related to the particular product.

This manual is copyright by Trio DataCom Pty Ltd. All rights reserved. No part of the documentation or the information supplied may be divulged to any third party without the express written permission of Trio DataCom Pty Ltd.

Some are proprietary to Trio DataCom Pty Ltd and are supplied for the purposes referred to in the accompanying documentation and must not be used for any other purpose. All such information remains the property of Trio DataCom Pty Ltd and may not be reproduced, copied, stored on or transferred to any other media or used or distributed in any way save for the express purposes for which it is supplied.

Products offered may contain software which is proprietary to Trio DataCom Pty Ltd. However, the offer of supply of these products and services does not include or infer any transfer of ownership of such proprietary information and as such reproduction or reuse without the express permission in writing from Trio DataCom Pty Ltd is forbidden. Permission may be applied for by contacting Trio DataCom Pty Ltd in writing.



Warning :- RF Exposure

The radio equipment described in this user manual emits low level radio frequency energy. The concentrated energy may pose a health hazard depending on the type of antenna used. In the case of a non-directional antenna do not allow people to come within 0.5 metres of the antenna when the transmitter is operating. In the case of a directional antenna do not allow people to come within 6 metres of the antenna when the transmitter is operating.

Related Products

ER450 Remote Data Radio
EB450 Base/Repeater Station
EH450 Hot Stand-by Base Station

Other Related Documentation and Products

Quick Start Guide
TVIEW+ Management Suite
Digital Orderwire Voice Module (EDOVM)
Stream Router/Multiplexer (95MSR)

Revision History

Issue 1	July 2002	Initial Release
Issue 2	August 2002	Added EH450 Quick Start Section and Specifications Section
Issue 3	November 2002	Major Edits to TVIEW and minor edits to quick start sections.



Contents

SECTION 1

Part A – Preface	2
Warranty	2
Important Notice	2
Related Products	2
Other Related Documentation and Products	2
Revision History	2
Part B – E Series Overview	4
Definition of E Series Data Radio	4
E Series Product Range	4
E Series – Features and Benefits	4
Model Number Codes	6
Standard Accessories	7
Part C – Applications	8
Generic Connectivity	8
Application Detail	8
Systems Architecture	9
Part D – System Planning and Design	11
Understanding RF Path Requirements	11
Examples of Predictive Path Modelling	12
Selecting Antennas	14
Data Connectivity	15
Power Supply and Environmental Considerations	18
Physical Dimensions of the Remote Data Radio	19
Physical Dimensions of the Base Station	20
Physical Dimensions of the Hot Standby Base Station	21
Part E – Getting Started	22
ER450 Quick Start Guide	22
EB450 Quick Start Guide	28
EH450 Quick Start Guide	31
Part F - Operational Features	36
Multistream functionality (SID codes)	36
Collision Avoidance (digital and RFCF based)	36
Digipeater Operation	36
TVIEW+ Diagnostics	36
Part G – Commissioning	37
Power-up	37
LED Indicators	37
Data Transfer Indications	37
Antenna Alignment and RSSI Testing	37
Link Establishment and BER Testing	37
VSWR Testing	37
Part H – Maintenance	38
Routine Maintenance Considerations	38

SECTION 2

Part I – TVIEW+ Management Suite - Programmer	40
Introduction	40
Installation	40
TVIEW+ Front Panel Programmer	41
Part J – TVIEW+ Management Suite - Remote Diagnostics & Network Controller	53
Introduction	53
System Description	53
Operating Instructions	55
Interpreting Poll Results	66
Part K – Appendices	67
Appendix A - Application and Technical Notes	67
Appendix B - Slip Protocol	67
Appendix C - Firmware Updates	68
Part L – Specifications	69
Part M – Support Options	70
Website Information	70
E-mail Technical Support	70
Telephone Technical Support	70
Contacting the Service Department	70

Part B – E Series Overview

Definition of E Series Data Radio

The E Series is a range of wireless modems designed for the transmission of data communications for SCADA, telemetry, and any other information and control applications that utilise ASCII messaging techniques. The E Series uses advanced “digital” modulation and signal processing techniques to achieve exceptionally high data throughput efficiency using traditional licensed narrow band radio channels.

The products are available in many frequency band and regulatory formats to suit spectrum bandplans in various continental regions. The range is designed for both fixed point to point (PTP), and multiple address (MAS) or point to multipoint (PMP) systems.

E Series Product Range

The E Series range consists of the basic *half duplex* “Remote” radio modem, an extended feature *full duplex* Remote radio modem, and ruggedised *Base Station* variants, including an optional *Hot Standby controller* to control two base station units in a redundant configuration.

Frequency band variants are indicated by the band prefix and model numbering. (See Model Number Codes)



ER450 Remote Radio



EB450 Base / Repeater Station



EH450 Hot Standby Base Station

E Series – Features and Benefits

Common Features and Benefits of the E Series Data Radio

- Up to 19200bps over-air data rates using programmable DSP based advanced modulation schemes
- Designed to various International regulatory requirements including FCC, ETSI and ACA
- Superior receiver sensitivity
- Fast data turnaround time <10ms
- Flash upgrade-able firmware – insurance against obsolescence
- Multi-function bi-colour Tx/Rx data LEDS showing Port activity (breakout box style), as well as LEDs indicating Tx, Rx, RF Signal, Data Synchronisation and DC Power status of the radio
- Rugged N type antenna connectors on all equipment
- High temperature transmitter foldback protection
- Two independent configurable data ports and separate system port
- Higher port speeds to support increased air-rate (up to 76800bps on Port A and 38400bps on Port B)
- Independent system port for interruption free programming and diagnostics (in addition to two (2) user ports)
- 9600bps in 12.5 kHz radio channels with ETSI specifications
- Remote over-the-air configuration of any radio from any location
- Multistream™ simultaneous data streams allows for multiple vendor devices / protocols to be transported on the one radio network
- Flexible data stream routing and steering providing optimum radio channel efficiency – complex data radio systems can be implemented with fewer radio channels
- The ability to duplicate data streams – that is, decode the same off-air data to two separate ports.
- Multi-function radio capable of dropping off one stream to a port and forward on or repeat (store and forward) the same or other data.
- Stand-alone internal store and forward operation – buffered store and forward operation even in the ER remote units
- Unique integrated C/DSMA collision avoidance technology permits simultaneous polling and spontaneous reporting operation in the same system
- Digital receiver frequency tracking for long term data reliability
- Network wide non intrusive diagnostics which runs simultaneously with the application

- Network wide diagnostics interrogation which can be performed from anywhere in the system including any remote site
- Diagnostics will route its way to any remote or base / repeater site regardless of how many base / repeater stations are interconnected
- Full range of advanced features available within Network Management and Remote Diagnostics package – BER testing, trending, channel occupancy, client / server operation, etc.
- On board memory for improving user data latency – increased user interface speeds
- Full CRC error checked data – no erroneous data due to squelch tails or headers
- Radio utilises world standard HDLC as its transportation protocol
- Various flow control and PTT control mechanisms
- Configurable backward compatibility with existing D Series modulation scheme for use within existing networks
- Digital plug in order wire option for commissioning and occasional voice communications without the need to inhibit users application data

Features and Benefits of ER450 Remote Data Radio

- Optional full duplex capable remote – separate Tx and Rx ports for connection to an external duplexer
- New compact and rugged die cast case with inbuilt heatsink
- Low power consumption with various sleep modes
- Rugged N type antenna connectors
- In-line power supply fuses
- Data Port “breakout box” style flow LEDs for easier troubleshooting

Features and Benefits of EB450 Standard Base / Repeater Station

- Competitively priced high performance base
- Incorporates a rugged 5W power amplifier module
- External input for higher stability 10MHz reference – GPS derived

Features and Benefits of EH450 Hot Standby Base / Repeater Station

- Individual and identical base stations with separate control logic changeover panel
- ALL modules are hot swappable without any user downtime
- Flexible antenna options – single, separate Tx & Rx, two Tx and two Rx
- Increased sensitivity with receiver pre-amplifier
- Both on-line and off-line units monitored regardless of active status
- External input for higher stability 10MHz reference – GPS derived

Model Number Codes

D, E & S Series Data Radios - Part Number Matrix = Tyxxx-aabb-bbb-cd

T **y** **x x x** - **a a** **b b b** - **c** **d**

Options - Base Stations*

- 0 = No Options
- 1 = 450MHz Band Reject (DUPLX450BR)
- 2 = 450MHz Band Reject (<9MHz split)(DUPLX450BR/5)
- 3 = 450MHz Band Pass (DUPLX450BP)
- 4 = 900MHz Band Reject (DUPLX900BR)
- 5 = 900MHz Band Pass (DUPLX900BP)
- 6 = 900MHz Band Pass (76MHz split)(DUPLX852/930)

Note: Specify Internally or Externally fitted. Externally filtered duplexes require feeder tails.

Options*

- 0 = No Options
- D = Diagnostics - [DIAGS/D, DIAGS/DH, DIAGS/E or DIAGS/EH] (D & E Series Only)
- H = Extended Temp Option [HITEMP]
- N = Remote Fitted into NEMA Enclosure [NEMA 4/R]
- F = Full Duplex Operation [ERFD450] (ER450 only)
- X = Full Duplex Operation [ERFD450 & DIAGS/E] (ER450 only)

Options - Remote Antenna Connector*

- 0 = No Options (Standard)
- N = N Connector (D Series only)
- S = SMA Connector (SR450 only)

RF Channel Data Rate & Bandwidth (Internal Modem)

D Series	E Series	S Series
A01 = ACA 4800bps in 12.5kHz	A01 = ACA 4800* / 9600bps in 12.5kHz	001 = 12.5kHz (No Modem Fitted)
A02 = ACA 9600bps in 25kHz	A02 = ACA 9600* / 19k2bps in 25kHz	002 = 25kHz (No Modem Fitted)
F01 = FCC 9600bps in 12.5kHz	F01 = FCC 9600* / 9600bps in 12.5kHz	241 = 2400bps in 12.5kHz [24SR]*
	F02 = FCC 19k2bps in 25kHz	242 = 2400bps in 25kHz [24SR]*
	E01 = ETSI 9600bps in 12.5kHz	482 = 4800bps in 25kHz [48SR]*
	E02 = ETSI 19k2bps in 25kHz	

Frequency (200 & 400 MHz range)

- 39 = 208 to 240MHz (Tx & Rx)
- 50 = 403 to 417MHz (Tx & Rx)
- 58 = (Tx) 406 to 421MHz (Rx) 415 to 430MHz
- 59 = (Tx) 415 to 430MHz (Rx) 406 to 421MHz
- 56 = 418 to 435MHz (Tx & Rx)
- 57 = 428 to 443MHz (Tx & Rx)
- 55 = 436 to 450MHz (Tx & Rx)
- 51 = 450 to 465MHz (Tx & Rx)
- 52 = 465 to 480MHz (Tx & Rx)
- 53 = 480 to 494MHz (Tx & Rx)
- 54 = 505 to 518MHz (Tx & Rx)
- 27 = (Tx) 511 to 515MHz (Rx) 501 to 505MHz
- 48 = 395 to 406MHz (Tx & Rx)

Frequency (900 MHz range) (D & S Series Only)

- 07 = (Tx) 847 to 857MHz (Rx) 923 to 933MHz (D Series only, 1W Full Duplex)
- 10 = (Tx) 848 to 858MHz (Rx) 920 to 934MHz
- 06 = (Tx) 923 to 933MHz (Rx) 847 to 857MHz (D Series only, 1W Full Duplex)
- 11 = (Tx) 920 to 934MHz (Rx) 848 to 858MHz
- 12 = 855 to 860MHz (Tx & Rx)
- 14 = (Tx) 925 to 943MHz (Rx) 906 to 924MHz
- 15 = (Tx) 904 to 922MHz (Rx) 925 to 943MHz
- 16 = 924 to 944MHz (Tx & Rx)

Note: Other frequency bands available upon request.

Generic Frequency Band

- 200 = 208 to 245MHz (D & S Series only)
- 450 = 400 to 518MHz (E & S Series only)
- 900 = 800 to 960MHz (D & S Series only)

Unit Type

- R = Remote Station
- B = Base / Repeater Station
- S = Standard Base / Repeater Station (D Series Only)
- H = Hot Standby Base / Repeater (D & E Series Only)

Model Type

- D = D Series Family
- E = E Series Family
- S = S Series Family

NOTES:

- * Additional charges apply. Must be ordered separately. Please refer to price list.
- # Provides compatibility with D Series radio
- Items in [] parenthesis refer to actual Trio part numbers

Standards: ACA - Australian Communications Authority
 FCC - Federal Communications Commission
 ETSI - European Telecommunication Standards Institute

Example:

E R 4 5 0 - 5 1 A 0 2 - D 0

The above example specifies: E Series, Remote Radio, generic 450MHz band, with a specific frequency of 450MHz to 465MHz, a 96/19.2kbps modem, with a bandwidth of 25kHz, diagnostics and standard N type connector.

Version: 11/02

Standard Accessories

Part Number	Description
Duplexers	
DUPLX450BR	Duplexer BAND REJECT 400-520 MHz for use with Base / Repeater / Links. For Tx / Rx frequency splits >9MHz. (Fitted Externally for a Link, Internally or Externally for Base / Repeater)
DUPLX450BR/5	Duplexer BAND REJECT 400-520 MHz for use with Base / Repeater / Links. For Tx / Rx frequency splits <9MHz. (Fitted Externally for a Link, Internally or Externally for Base / Repeater)
DUPLX450BP	Duplexer PSEUDO BAND PASS Cavity 400-520 MHz for External use with Base / Repeater / Links.

Notes:

1. Frequencies must be specified at time of order.
2. Interconnecting (Feeder Tail) cables must be ordered separately for Externally fitted Duplexers.

Antennas

ANT450/9A	Antenna Yagi 6 Element 9dBd Aluminium 400-520 MHz c/w mtg clamps
ANT450/9S	Antenna Yagi 6 Element 9dBd S/Steel 400-520 MHz c/w mtg clamps
ANT450/13A	Antenna Yagi 15 Element 13dBd Aluminium 400-520 MHz c/w mtg clamps.
ANT450/13S	Antenna Yagi 15 Element 13dBd S/Steel 400-520 MHz c/w mtg clamps.
ANTOMNI/4	Antenna Omni-directional Unity Gain Side Mount Dipole 400-520 MHz c/w galv. clamp
ANT450/D	Antenna Omni-directional Unity Gain Ground Independant Dipole 400-520 MHz c/w 3m cable, mounting bracket & BNC connector
ANT450/6OM	Antenna Omni-directional 6dBd 400-520 MHz c/w mtg clamps
ANT450/9OM	Antenna Omni-directional 9dBd 400-520 MHz c/w mtg clamps

Note:

1. Frequencies must be specified at time of order.

Power Supplies

PS13V82A	Power Supply 13.8V 2A 240VAC
PS13V810A	Power Supply Switch Mode 240VAC 13.8V 10A for Base Stations – Battery Charge Capability

Part Number	Description
RF Cables and Accessories	
NM/NM/TL	Feeder Tail - N Male to N Type Male 50cm fully sweep tested
NM/NM/TLL	Feeder Tail - N Male to N Type Male 1 metre fully sweep tested
RFCAB5M	5.0m RG-58 type Antenna Feeder Cable terminated with N type Male Connectors
RFCAB5M2	5.0m RG-213 type Antenna Feeder Cable terminated with N type Male Connectors
RFCAB10M	10.0m RG-213 type Antenna Feeder Cable terminated with N type Male Connectors
RFCAB20M	20.0m RG-213 type Antenna Feeder Cable terminated with N type Male Connectors
RFCAB20M4	20.0m LDF4-50 type (1/2" foam dielectric) Antenna Feeder Cable terminated with N type Male Connectors
LGHTARRST	Lightning Surge Arrestor In-line N Female to N Female

Multiplexers

95MSR/6	Multiplexer/Stream Router – 6 Port with RS-232 I/faces and Manual
95MSR/9	Multiplexer/Stream Router – 9 Port with RS-232 I/faces and Manual

Network Management Diagnostics

DIAGS/E	Network Management and Remote Diagnostics Facilities per Radio – E Series
DIAGS/EH	Network Management and Remote Diagnostics Facilities – E Series for EH450

Software

TVIEW+	Configuration, Network Management and Remote Diagnostics Software
--------	---

Other

NEMA 4 /R	Stainless Steel Enclosure for Remote Site Equipment. Size 600mm (h) x 600mm (d) x 580mm (w) – Room for Third Party RTU / PLC equip. (Approx. 400(h) x 600(d) x 580mm(w))
HITEMP	Extended Temperature Option for S, D and E Series Radios -30 to +70C
EDOVM	Digital Order Wire Voice Module
ERFD450	ER450.... Conversion to Full Duplex Operation (N Type – Tx Port, SMA - Type Rx Port) <i>Note: Requires external duplexer</i>
ERFDTRAY	19" Rack Tray for Mounting of ER450 Full Duplex Radio and External Band Reject Duplexer

Part C – Applications

Generic Connectivity

The E Series has been designed for SCADA and telemetry applications, and any other applications that use an ASCII communications protocol, and which connect physically using the RS232 interface standard (although converters can be used to adapt other interfaces such as RS422/485, RS530/V35, G703 etc).

Any protocol that can be displayed using a PC based terminal program operating via a serial comm port is suitable for transmission by the E Series radio modems.

An ASCII protocol is any that consists of message strings formed from ASCII characters, that being defined as a 10 or 11 bit block including start and stop bits, 7 or 8 data bits and optional parity bit(s). Port set-up dialog that includes the expressions "N,8,1", or E,7,2" or similar indicate an ASCII protocol.

Most of the dominant telemetry industry suppliers utilise proprietary ASCII protocols, and also common "open standard" industry protocols such as DNP3, MODBUS, TCP/IP, and PPP. These are all ASCII. based protocols.

Industries and Applications

The E Series products are widely used in point-to-point and point-to-multipoint (multiple access) applications for remote interconnection of PLC's, RTU's, dataloggers, and other data monitoring and control devices including specialist utility devices (such as powerline ACR's). In addition, other applications such as area wide security and alarm systems, public information systems (traffic flow and public signage systems) and environmental monitoring systems.

Application Detail

SCADA Systems

This is where one or more centralised control sites are used to monitor and control remote field devices over wide areas. Examples include regional utilities monitoring and controlling networks over entire shires or a greater city metropolis'. Industry sectors include energy utilities (gas and electricity distribution), water and sewerage utilities, and catchment and environment groups (rivers, dams, and catchment management authorities).

Telemetry Systems

Dedicated telemetry control systems interconnecting sequential devices where cabling is not practical or distances are considerable.

Examples include ore conveyor or slurry pipeline systems, simple water systems (pump and reservoir interlinking), broadcast industry (linking studio to transmitter) etc.

Information Systems

Public Information systems such as freeway vehicle flow and travel time monitoring, and feedback signage, parking signage systems, meteorological stations etc.

Systems Architecture

Point-to-Point

This simple system architecture provides a virtual connection between the two points, similar to a cable. Dependant of the hardware chosen, it is possible to provide a full duplex connection (i.e. data transfer in both directions simultaneously) if required.

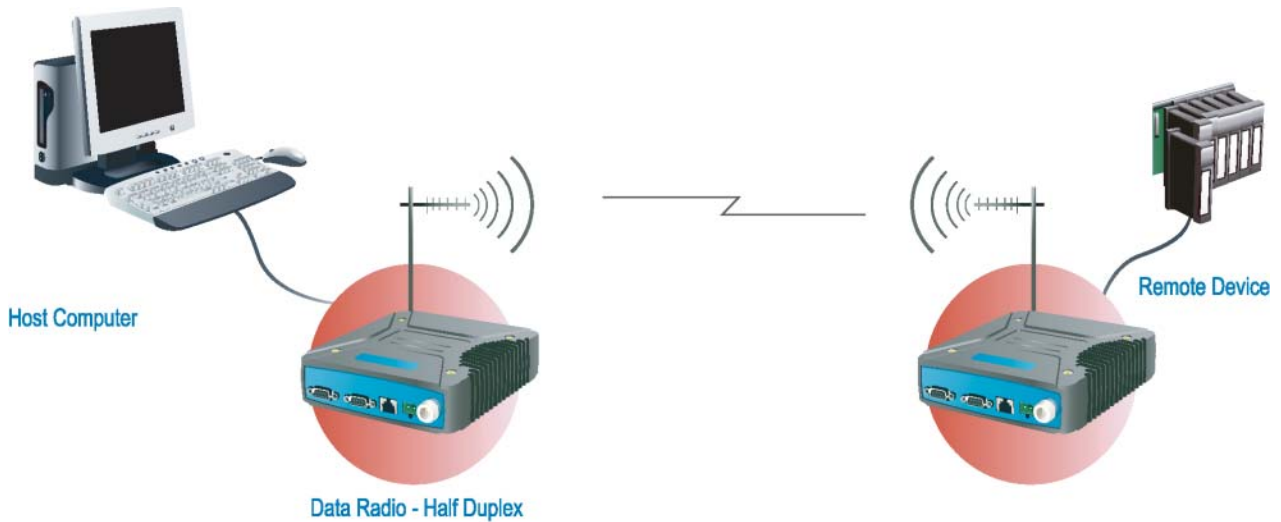

Point-to-Multipoint Systems

In a multiple access radio system, messages can be broadcast from one (master) site to all others, using a half duplex radio system, or from any site to all others, using a simplex radio channel.

Half duplex systems often utilise a full duplex master, to make the system simpler, and to operate faster.

In either case, it will be necessary for the application to support an addressing system, since the master needs to be able to select which remote device it wishes to communicate to. Normally, the radio system is allowed to operate “transparently”, allowing the application’s protocol to provide the addressing, and thus control the traffic. Where the application layer does not provide the addressing, the E Series can provide it using SID codes™. (See Part F - Operational Features)

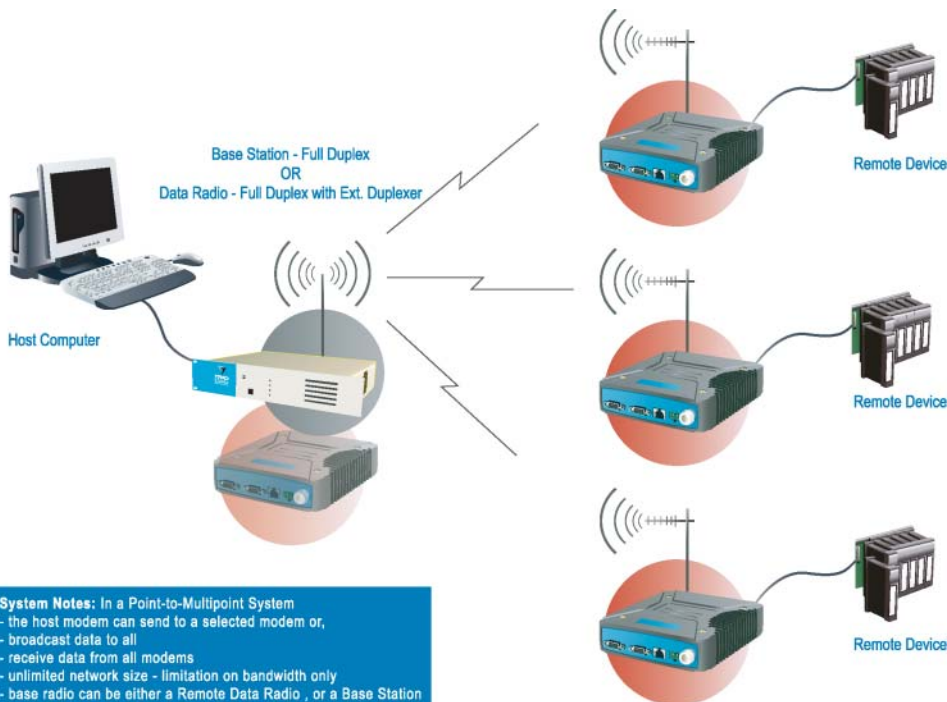

System Notes: In a Point-to-Multipoint System

- the host modem can send to a selected modem or, broadcast data to all
- receive data from all modems
- unlimited network size - limitation on bandwidth only
- base can be either a Remote Data Radio , or a Base Station

Digipeater Systems

This configuration is used where all sites are required to communicate via a repeater site. A repeater site is used because it has a position and/or height advantage and thus provides superior or extended RF coverage. The radio modem at the repeater does not have to be physically connected to the application's master

site. Information from the application's master is transmitted to the repeater via radio, and the repeater then relays this information to the other field sites. In this scenario, the repeater is the master from an RF point of view, and the application master is effectively a "remote" from an RF point of view, even though it is controlling the data transfer on the system.

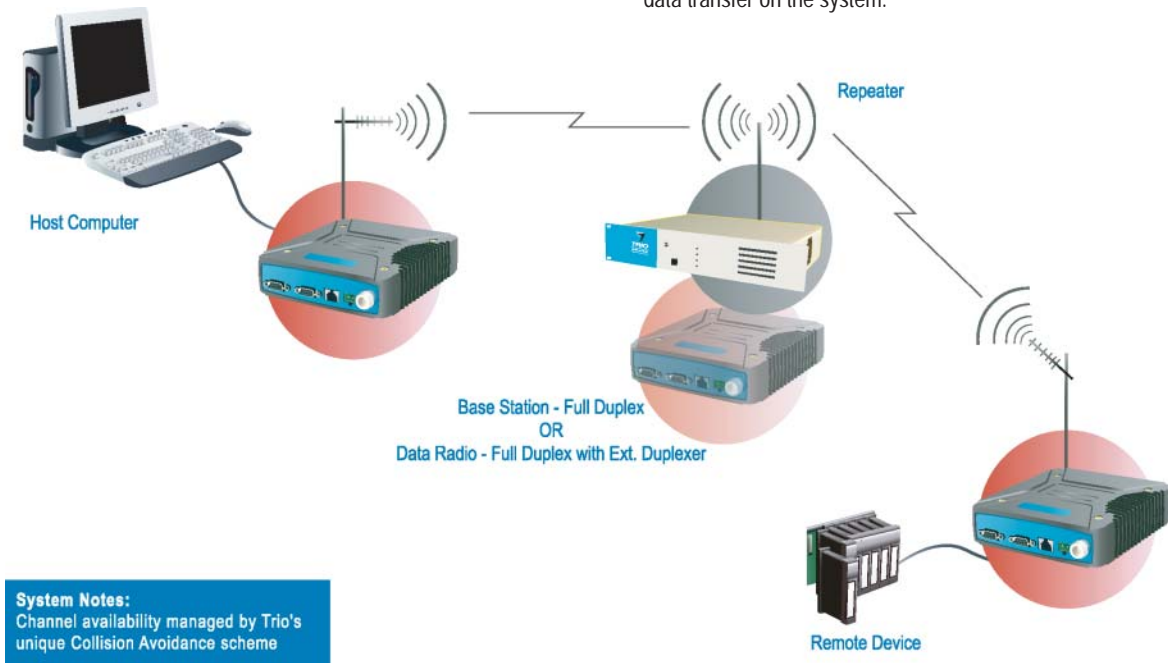

System Notes:
Channel availability managed by Trio's unique Collision Avoidance scheme

Store and Forward Systems

Store and forward is used as a way of extending RF coverage by repeating data messages from one site to another.

In this case it is necessary for all units on the system to operate in half duplex mode (only key-up when transmitting data), so that each site is free to hear received signals from more than one source.

This can be done globally using the inbuilt data repeating functions, or selectively using intelligent address based routing features available in some PLC/RTU protocols.

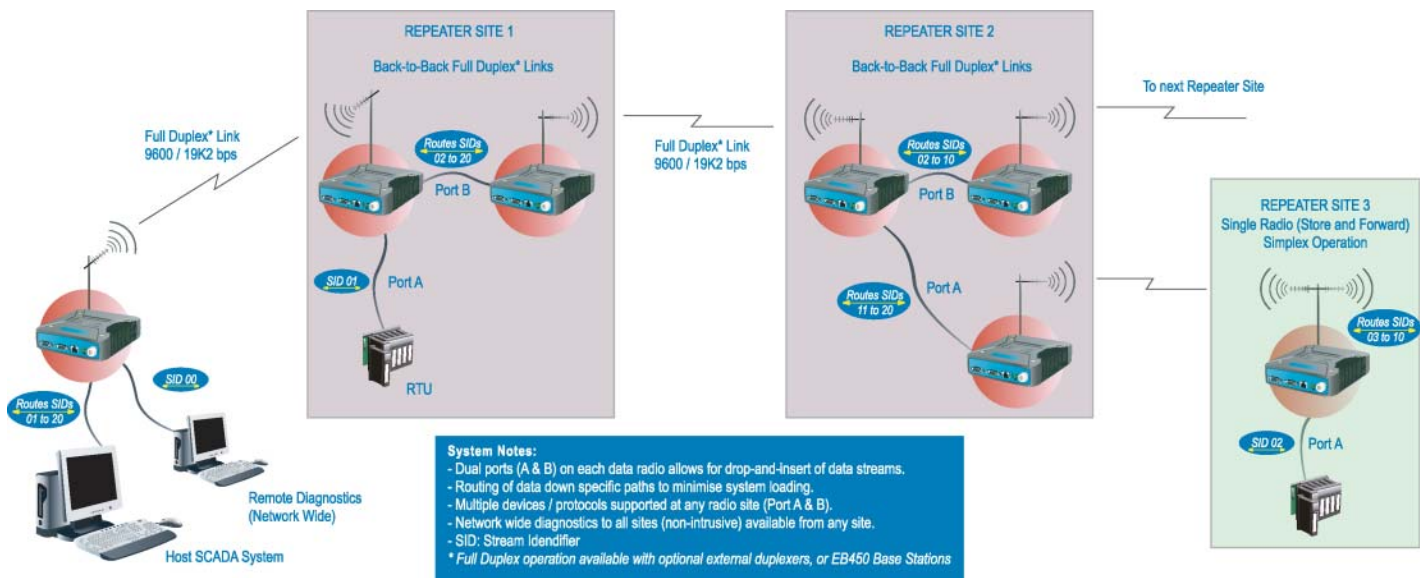

Part D – System Planning and Design

Understanding RF Path Requirements

A radio modem needs a minimum amount of received RF signal to operate reliably and provide adequate data throughput.

In most cases, spectrum regulatory authorities will also define or limit the amount of signal that can be transmitted, and the transmitted power will decay with distance and other factors, as it moves away from the transmitting antenna.

It follows, therefore, that for a given transmission level, there will be a finite distance at which a receiver can operate reliably with respect to the transmitter.

Apart from signal loss due to distance, other factors that will decay a signal include obstructions (hills, buildings, foliage), horizon (effectively the bulge between two points on the earth), and (to a minimal extent at UHF frequencies) factors such as fog, heavy rain-bursts, dust storms, etc.

In order to ascertain the available RF coverage from a transmitting station, it will be necessary to consider these factors. This can be done in a number of ways, including

- (a) using basic formulas to calculate the theoretically available signal - allowing only for free space loss due to distance,
- (b) using sophisticated software to build earth terrain models and apply other correction factors such as earth curvature and the effects of obstructions, and
- (c) by actual field strength testing.

It is good design practice to consider the results of at least two of these models to design a radio path.

Examples of Predictive Path Modelling

Clear line of site

Radio path with good signal levels, attenuated only by free space loss.

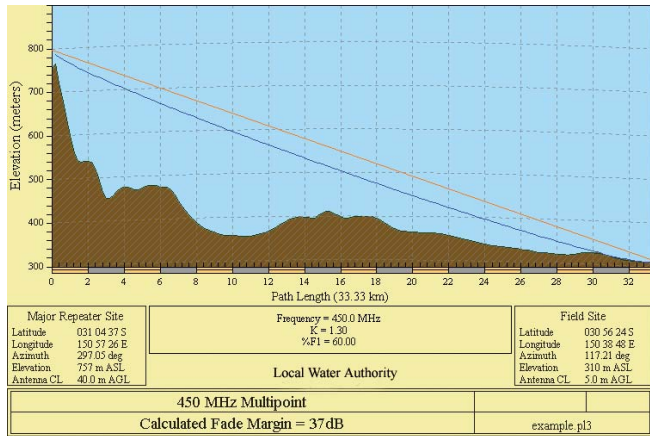

goodpath.pl3	Major Repeater Site	Field Site
Elevation (m)	756.69	309.67
Latitude	031 04 37.49 S	030 56 24.00 S
Longitude	150 57 26.34 E	150 38 48.00 E
Azimuth	297.05	117.21
Antenna Type	ANT450/6OM	ANT450/9AL
Antenna Height (m)	40.00	5.00
Antenna Gain (dBi)	8.15	11.15
Antenna Gain (dBd)	6.00	9.00
TX Line Type	LDF4-50	LDF4-50
TX Line Length (m)	40.00	5.00
TX Line Unit Loss (dB/100 m)	6.79	6.79
TX Line Loss (dB)	2.72	0.34
Connector Loss (dB)	2.00	2.00
Frequency (MHz)	450.00	
Path Length (km)	33.33	
Free Space Loss (dB)	115.99	
Diffraction Loss (dB)	0.00	
Net Path Loss (dB)	103.75	103.75
Radio Type Model	EB450	ER450
TX Power (watts)	5.00	1.00
TX Power (dBW)	6.99	0.00
Effective Radiated Power (watts)	6.71	4.63
Effective Radiated Power (dBW)	8.27	6.66
RX Sensitivity Level (uv)	0.71	1.26
RX Sensitivity Level (dBW)	-140.00	-135.00
RX Signal (uv)	45.93	102.70
RX Signal (dBW)	-103.75	-96.76
RX Field Strength (uv/m)	453.14	545.42
Fade Margin (dB)	36.25	38.24
Raleigh Service Probability (%)	99.976	99.985

Obstructed Radio Path

This path has an obstruction that will seriously degrade the signal arriving at the field site.

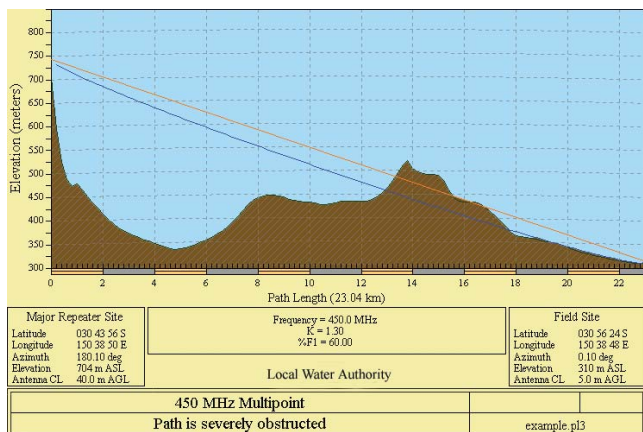

obspath.pl3	Major Repeater Site	Field Site
Elevation (m)	703.83	309.67
Latitude	030 43 55.92 S	030 56 24.00 S
Longitude	150 38 49.51 E	150 38 48.00 E
Azimuth	180.10	0.10
Antenna Type	ANT450/6OM	ANT450/9AL
Antenna Height (m)	40.00	5.00
Antenna Gain (dBi)	8.15	11.15
Antenna Gain (dBd)	6.00	9.00
TX Line Type	LDF4-50	LDF4-50
TX Line Length (m)	40.00	5.00
TX Line Unit Loss (dB/100 m)	6.79	6.79
TX Line Loss (dB)	2.72	0.34
Connector Loss (dB)	2.00	2.00
Frequency (MHz)	450.00	
Path Length (km)	23.04	
Free Space Loss (dB)	112.78	
Diffraction Loss (dB)	16.71	
Net Path Loss (dB)	117.25	117.25
Radio Type Model	EB450	ER450
TX Power (watts)	5.00	1.00
TX Power (dBW)	6.99	0.00
Effective Radiated Power (watts)	6.71	4.63
Effective Radiated Power (dBW)	8.27	6.66
RX Sensitivity Level (uv)	0.71	1.26
RX Sensitivity Level (dBW)	-140.00	-135.00
RX Signal (uv)	9.70	21.70
RX Signal (dBW)	-117.25	-110.26
RX Field Strength (uv/m)	95.74	115.23
Fade Margin (dB)	22.75	24.74
Raleigh Service Probability (%)	99.470	99.665

Effect of Earth Curvature on Long Paths

This path requires greater mast height to offset the earth curvature experienced at such a distance (73km).

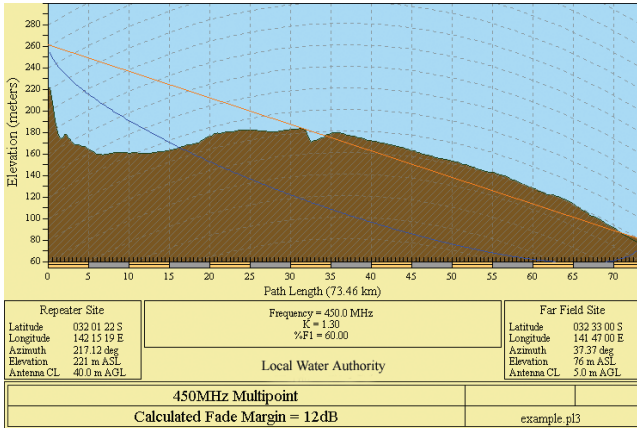

longpath.pl3	Repeater Site	Far Field Site
Elevation (m)	221.26	75.58
Latitude	032 01 21.63 S	032 33 00.00 S
Longitude	142 15 19.26 E	141 47 00.00 E
Azimuth	217.12	37.37
Antenna Type	ANT450/6OM	ANT450/9AL
Antenna Height (m)	40.00	5.00
Antenna Gain (dBi)	8.15	11.15
Antenna Gain (dBd)	6.00	9.00
TX Line Type	LDF4-50	LDF4-50
TX Line Length (m)	40.00	5.00
TX Line Loss (dB)	6.79	6.79
Connector Loss (dB)	2.00	0.34
Frequency (MHz)	450.00	
Path Length (km)	73.46	
Free Space Loss (dB)	122.85	
Diffraction Loss (dB)	22.94	
Net Path Loss (dB)	133.55	133.55
Radio Type Model	EB450	ER450
TX Power (watts)	5.00	1.00
TX Power (dBW)	6.99	0.00
Effective Radiated Power (watts)	6.72	4.64
Effective Radiated Power (dBW)	8.27	6.66
RX Sensitivity Level (uv)	0.71	1.26
RX Sensitivity Level (dBW)	-140.00	-135.00
RX Signal (uv)	1.49	3.32
RX Signal (dBW)	-133.55	-126.56
RX Field Strength (uv/m)	14.65	17.64
Fade Margin (dB)	6.45	8.44
Raleigh Service Probability (%)	79.735	86.656

Selecting Antennas

There are basically two types of antennas – omni directional, and directional.

Omnidirectional antennas are designed to radiate signal in a 360 degree segment around the antenna. Basic short range antennas such as folded dipoles and ground independent whips are used to radiate the signal in a “ball” shaped pattern. High gain omni antennas such as the “co-linear” compress the sphere of energy into the horizontal plane, providing a relatively flat “disc” shaped pattern which goes further because all of the energy is radiated in the horizontal plane.

Directional antennas are designed to concentrate the signal into “beam” of energy for transmission in a single direction (ie for point-to-point or remote to base applications).

Beamwidths vary according to the antenna type, and so can be selected to suit design requirements. The most common UHF directional antenna is the yagi, which offers useable beam widths of 30-50 degrees. Even higher “gain” is available using parabolic “dish” type antennas such as gridpacks.

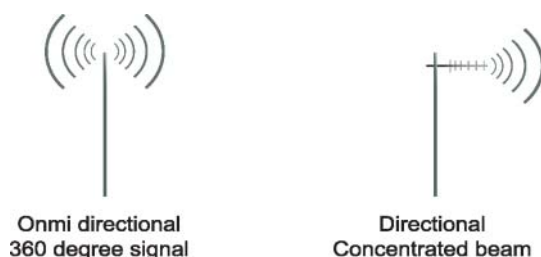

Antenna Gain

By compressing the transmission energy into a disc or beam, the antenna provides more energy (a stronger signal) in that direction, and thus is said to have a performance “gain” over a basic omni antenna. Gain is usually expressed in dBd, which is referenced to a standard folded dipole. Gain can also be expressed in dBi, which is referenced to a theoretical “isotropic” radiator. Either way, if you intend to send and receive signals from a single direction, there is advantage in using a directional antenna - both due to the increased signal in the wanted direction, and the relatively decreased signal in the unwanted direction (i.e. “interference rejection” properties).

Tuning the Antenna

Many antennas are manufactured for use over a wide frequency range. Typical fixed use antennas such as folded dipoles and yagis are generally supplied with the quoted gain available over the entire specified band range, and do not require tuning. Co-linear antennas are normally built to a specific frequency specified when ordering.

With mobile “whip” type antennas, it is sometimes necessary to “tune” the antenna for the best performance on the required frequency. This is usually done by trimming an antenna element whilst measuring VSWR, or simply trimming to a manufacturer supplied chart showing length vs frequency. These antennas would normally be supplied with the tuning information provided.

Antenna Placement

When mounting the antenna, it is necessary to consider the following criteria:

The mounting structure will need to be solid enough to withstand additional loading on the antenna mount due to extreme wind, ice or snow (and in some cases large birds).

For omni directional antennas, it is necessary to consider the effect of the mounting structure (tower mast or building) on the radiation pattern. Close in structures, particularly steel structures, can alter the radiation pattern of the antenna. Where possible, omni antennas should always be mounted on the top of the mast or pole to minimise this effect. If this is not possible, mount the antenna on a horizontal outrigger to get it at least 1-2m away from the structure. When mounting on buildings, a small mast or pole (2-4m) can significantly improve the radiation pattern by providing clearance from the building structure.

For directional antennas, it is generally only necessary to consider the structure in relation to the forward radiation pattern of the antenna, unless the structure is metallic, and of a solid nature. In this case it is also prudent to position the antenna as far away from the structure as is practical. With directional antennas, it is also necessary to ensure that the antenna cannot move in such a way that the directional beamwidth will be affected. For long yagi antennas, it is often necessary to install a fibreglass strut to stabilise the antenna under windy conditions.

Alignment of Directional Antennas

This is generally performed by altering the alignment of the antenna whilst measuring the received signal strength. If the signal is weak, it may be necessary to pre-align the antenna using a compass, GPS, or visual or map guidance in order to “find” the wanted signal. Yagi antennas have a number of lower gain “lobes” centred around the primary lobe. When aligning for best signal strength, it is important to scan the antenna through at least 90 degrees, to ensure that the centre (strongest) lobe is identified.

When aligning a directional antenna, avoid placing your hands or body in the vicinity of the radiating element or the forward beam pattern, as this will affect the performance of the antenna.

RF Feeders and Protection

The antenna is connected to the radio modem by way of an RF feeder. In choosing the feeder type, one must compromise between the loss caused by the feeder, and the cost, flexibility, and bulk of lower loss feeders. To do this, it is often prudent to perform path analysis first, in order to determine how much “spare” signal can be allowed to be lost in the feeder. The feeder is also a critical part of the lightning protection system.

All elevated antennas may be exposed to induced or direct lightning strikes, and correct grounding of the feeder and mast are an essential part of this process. Gas discharge lightning arresters should also be fitted to any site that stands elevated or alone, particularly in rural areas.

Common Cable Types	Loss per meter @ 450MHz	Loss per 10m @ 450MHz
RG58C/U	0.4426dB	4.4dB
RG213/U	0.1639dB	1.6dB
FSJ1-50 (¼" superflex)	0.1475dB	1.5dB
LDF4-50 (1/2" heliax)	0.0525dB	0.52dB
LDF5-50 (7/8" heliax)	0.0262dB	0.3dB



Data Connectivity

The V24 Standard

The E Series radio modems provide two asynchronous V24 compliant RS232 ports for connection to serial data devices.

There are two types of RS232 interfaces – DTE and DCE.

DTE stands for *data terminal equipment* and is generally applied to any intelligent device that has a need to communicate to another device via RS232. For example: P.C. Comm ports are always DTE, as are most PLC and RTU serial ports.

DCE stands for *data communication equipment* and is generally applied to a device used for sending data over some medium (wires, radio, fibre etc), i.e. any MODEM.

The standard interface between a DTE and DCE device (using the same connector type) is a straight through cable (ie each pin connects to the same numbered corresponding pin at the other end of the cable).

The “V24” definition originally specified the DB25 connector standard, but this has been complicated by the emergence of the DB9 (pseudo) standard for asynch devices, and this connector standard has different pin assignments.

The wiring standard is “unbalanced”, and provides for three basic data transfer wires (TXD, RXD, and SG – signal ground).

Hardware Handshaking

Hardware handshake lines are also employed to provide flow control, however (in the telemetry industry) many devices do not always support all (or any) flow control lines.

For this reason, the E Series modems can be configured for full hardware flow control, or no flow control at all (simple 3 wire interface).

Note: that when connecting devices together with differing handshake implementations, it is sometimes necessary to “loop” handshake pins in order to fool the devices handshaking requirements.

In telemetry applications (particularly where port speeds can be set to the same rate as the radio systems over-air rate) then flow control, and therefore handshaking, is usually NOT required. It follows that any devices that CAN be configured for “no flow control” should be used in this mode to simplify cabling requirements.

Handshaking lines can generally be looped as follows:

DTE (terminal) – loop RTS to CTS, and DTR to DSR and DCE.

DCE (modem) - loop DSR to DTR and RTS (note-not required for E Series modem when set for **no handshaking**).

Cable Wiring Diagrams

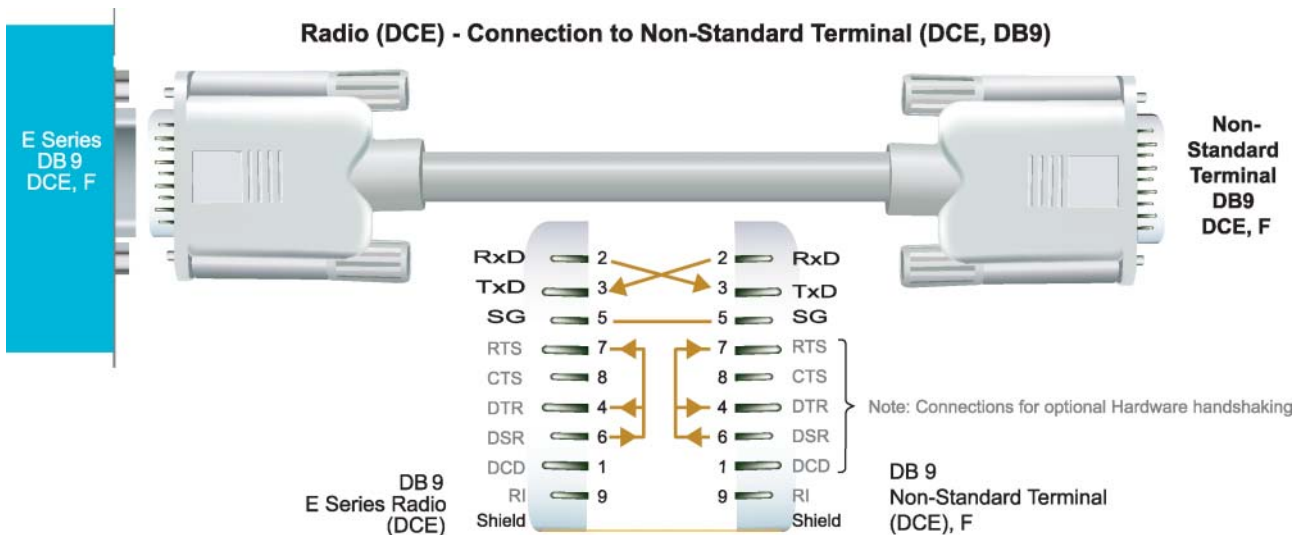
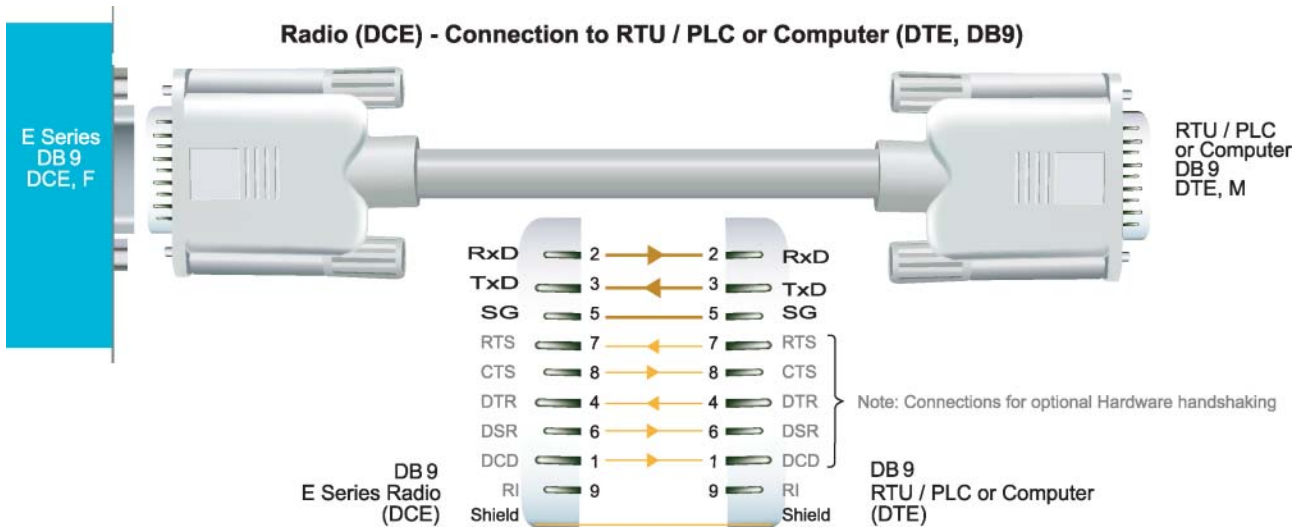

Cable Wiring Diagrams

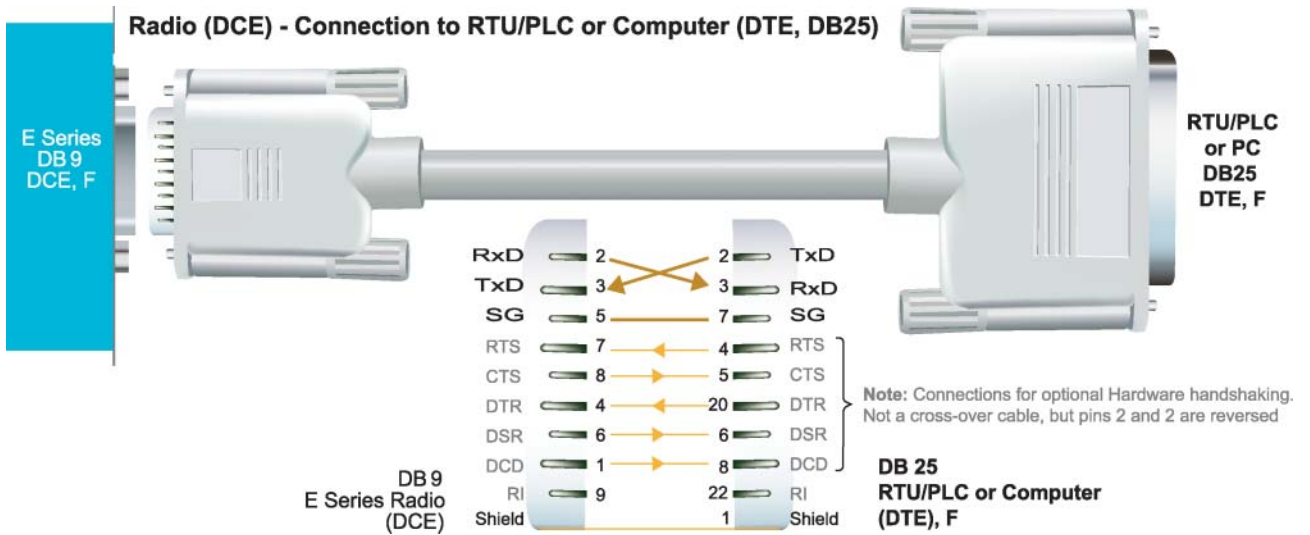

RS232 Connector Pin outs (DCE)
Port A and B, Female DB9

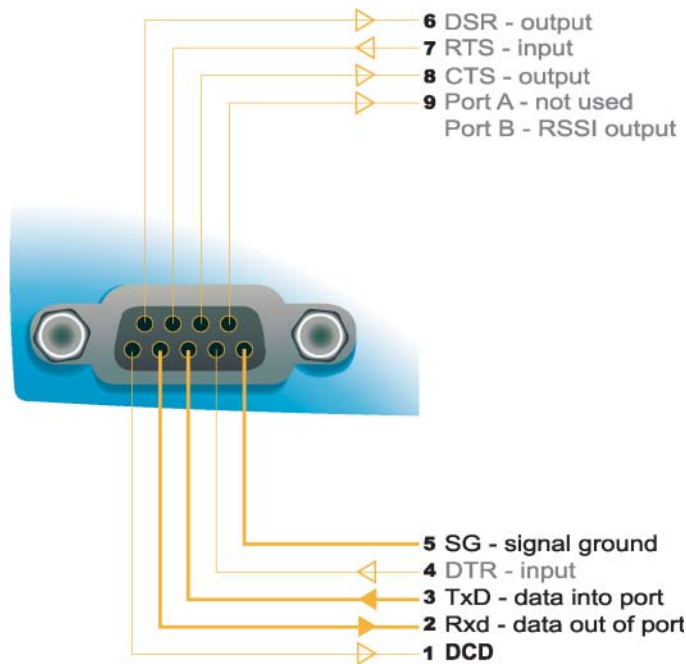

Power Supply and Environmental Considerations

General

When mounting the equipment, consideration should be given to the environmental aspects of the site. The cabinet should be positioned so that it is shaded from hot afternoon sun, or icy cold wind. Whilst the radios are designed for harsh temperature extremes, they will give a longer service life if operated in a more stable temperature environment. In an industrial environment, the radio modems should be isolated from excessive vibration, which can destroy electronic components, joints, and crystals.

The cabinet should provide full protection from moisture, dust, corrosive atmospheres, and other aspects such as ants and small vermin (who's residues can be corrosive or conductive). The radio modem will radiate heat from the in-built heatsink, and the higher the transmitter duty cycle, the more heat will be radiated from the heatsink. Ensure there is sufficient ventilation in the form of passive or forced air circulation to ensure that the radio is able to maintain quoted temperature limits.

Power Supply

The power supply should provide a clean, filtered DC source. The radio modem is designed and calibrated to operate from a 13.8VDC regulated supply, but will operate from 10-15 volts (filtered) DC.

The power supply must be able to supply sufficient current to provide clean filtered DC under the full current conditions of the radio modem (ie when transmitting full RF power). The current requirement is typically 120mA (230mA for EB450) in receive mode, and will vary in transmit mode according to RF output power level (typically 0.5-1.5 amps, 1.3-2.5 amps for EB450).

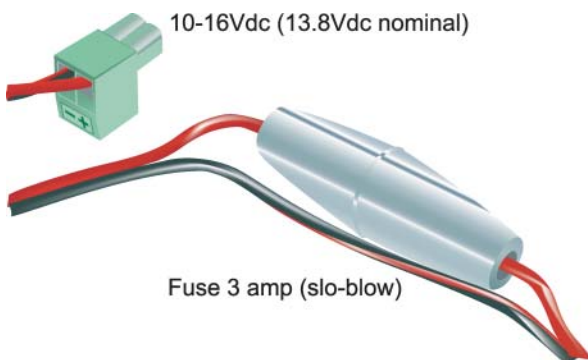

Caution: There is **NO** internal replaceable fuse, and therefore the radio modem **MUST** be externally fused with the fuse holder provided (ER450: 3 amp slo-blow fuse, EB450: 5 amp fast-blow fuse).

Solar Applications

In solar or battery-backed installations, a battery management unit should be fitted to cut off power to the radio when battery levels fall below the minimum voltage specification of the radio. In solar applications, a solar regulation unit **MUST ALSO** be fitted to ensure that the radio (and battery) is protected from excessive voltage under full sun conditions.

When calculating solar and battery capacity requirements, the constant current consumption will be approximately equal to the transmit current multiplied by the duty cycle of the transmitter, plus the receive current multiplied by the (remaining) duty cycle of the receiver.

The Tx/Rx duty cycle will be entirely dependent on the amount of data being transmitted by the radio modem, unless the device has been configured for continuous transmit, in which case the constant current consumption will be equal to the transmit current only (at 100% duty cycle).

Site Earthing

The radio must not be allowed to provide a ground path from chassis to (DB9) signal ground or (-) battery ground. Ensure that the chassis mounting plate, power supply (-) earth, RTU terminal device, and lightning arrester (if fitted), are all securely earthed to a common ground point to which an earth stake is attached. Please pay particular attention to 24VDC PLC systems using DC-DC converters to supply 13.8Vdc.

Physical Dimensions of the Remote Data Radio - ER450



Physical Dimensions of the Base Station - EB450



Physical Dimensions of the Hot Standby Base Station - EH450



Part E – Getting Started

ER450 Quick Start Guide

Introduction

Welcome to the *ER450 Quick Start Guide*. This guide provides step-by-step instructions, with simple explanations to get you up-and-running.



Mounting and Environmental Considerations

The ER450 radio comes complete with a mounting cradle and is attached to a panel or tray by means of screws or bolts, using the hole slots provided.

Note: In high power or high temperature applications, it is desirable to mount the radio with the heatsink uppermost to allow ventilation for the heatsink.

The radio should be mounted in a clean and dry location, protected from water, excessive dust, corrosive fumes, extremes of temperature and direct sunlight. Please allow sufficient passive or active ventilation to allow the radio modem's heatsink to operate efficiently.

Typical Radio Setup

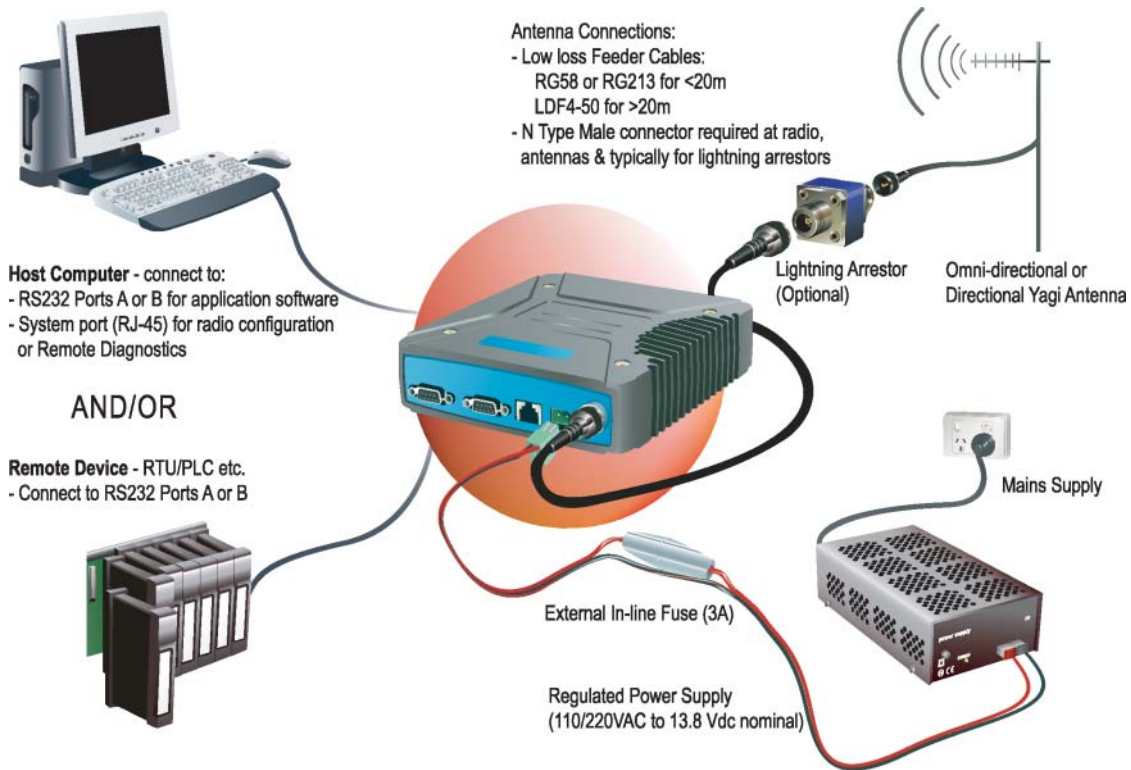

ER450 Connections Layout

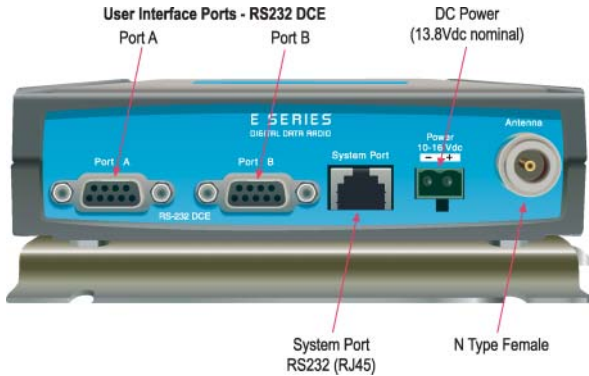

Connecting Antennas and RF Feeders

The RF antenna system should be installed in accordance with the manufacturers notes.

The RF connector used on the E Series radios are N Type female connectors. Always use good quality low loss feeder cable, selected according to the length of the cable run. Ensure all external connections are waterproofed using amalgamating tape.

Preset directional antennas in the required direction using a compass, GPS, or visual alignment and ensure correct polarisation (vertical or horizontal).



Communications Ports

System Port – RJ45

The System Port (available front and rear on EB/EH450) is a multi-function interface used for:

- Programming / Configuration of the radio
- Remote Diagnostics connections

To access these functions use the standard E Series System Cable assembly (RJ45 Cable and RJ45 to DB9 Adaptor).

System Port pinout assignments:

- Pin 1 System port data out (RS232)
- Pin 2 System port data in (RS232)
- Pin 3 Not used
- Pin 4 Shutdown
- Pin 5 Not used
- Pin 6 Not used
- Pin 7 Ground
- Pin 8 External PTT

Special user pinouts:

- Shutdown (Pin 4) - Active low for power save function
- External PTT (Pin 8) - Provides a manual PTT override facility for enabling the transmitter. For testing this can be activated by connecting PTT (Pin 8) to Gnd (Pin 7).

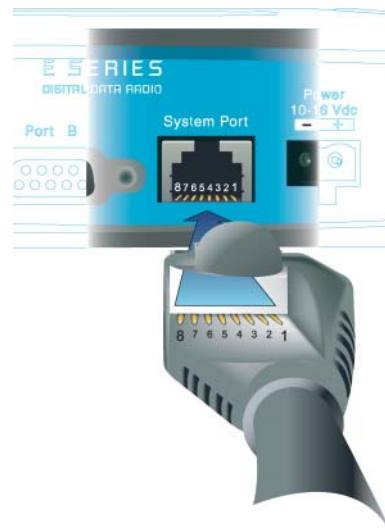

User Interfaces – Ports A & B

Each user port (A & B) is wired as a RS232 DCE, configurable for no handshaking (3-wire) interface, or for hardware or software (X-on/X-off) flow control. In most systems flow control is not required, in which case only 3 wires need to be connected between the radio and the application device.

Typical pins used:

- Pin 2 (RxD) - data output from the radio modem,
- Pin 3 (TxD) - data input to the radio modem,
- Pin 5 (SG) - signal ground.

See Part D – System Planning and Design - Data Connectivity, for further details of other cable configurations.

**RS232 Connector Pin outs (DCE)
Port A and B, Female DB9**

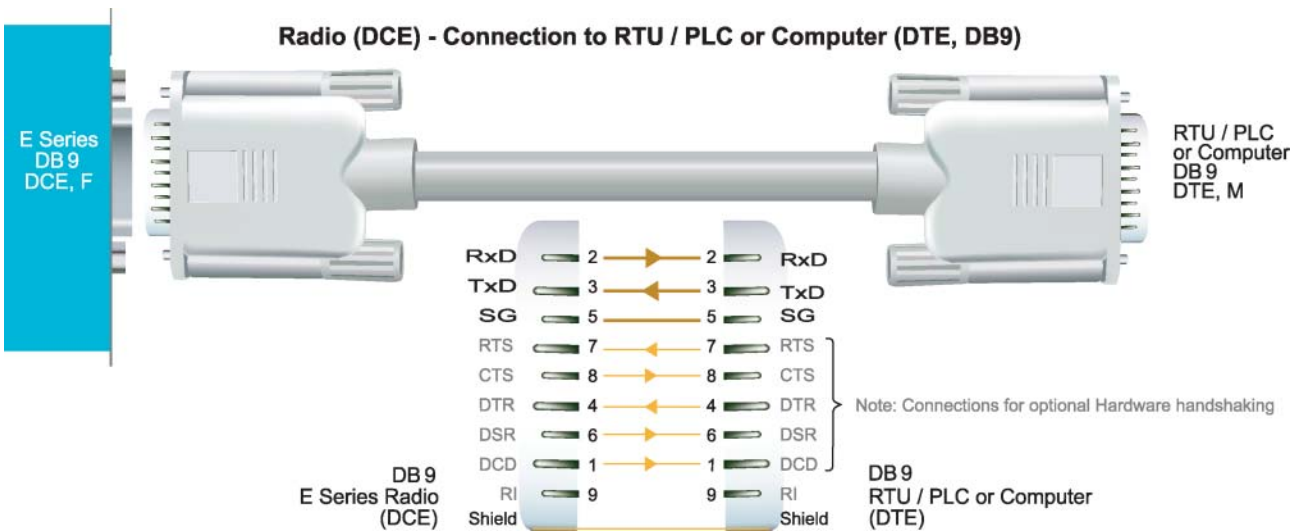
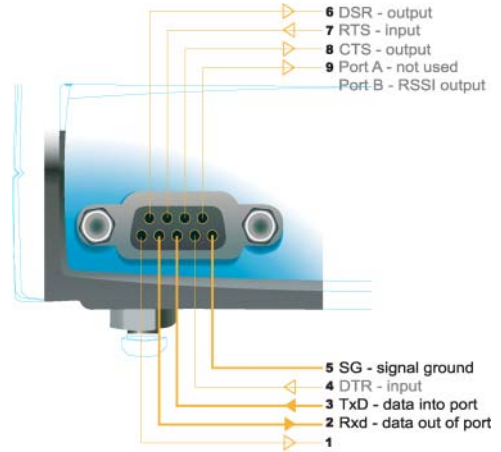

Activating the Transmitter

In most systems, the transmitter by default is controlled automatically by the radio when it has data to transmit.

In some systems, such as full duplex point-to-point links or full duplex point-to-multipoint base stations, it is desirable to run the transmitter all the time (hot keyed).

Two mechanisms are provided to do this:

- the radio modem can be configured to transmit continuously whenever powered, or

- the radio modem can be configured to transmit whenever an external RTS signal (Pin 7) is applied to one (or either) user ports. (To simulate an external RTS input, loop pins 6 to 7).

To operate in these modes, the radio must be configured via the programming software.



Caution: When the radio is configured to transmit continuously, ensure an RF load is present BEFORE applying power to the unit.

Power Supply Requirements

The E Series radio modem is designed and calibrated to operate from a filtered 13.8Vdc regulated supply, but will operate from a 10-16Vdc (11-16Vdc for EB450 & EH450) range.

The current requirement is typically 120mA (230mA for EB450) in receive mode, and will vary in transmit mode according to RF output power level (typically: ER450 0.5-1.5 amps, EB450 1.3-2.5 amps, EH450 2-3.2 amps).

Caution: There is **NO** internal replaceable fuse, and therefore the radio modem **MUST** be externally fused with the fuse holder provided (ER450: 3 amp slo-blow fuse, EB450: 5 amp fast-blow fuse).

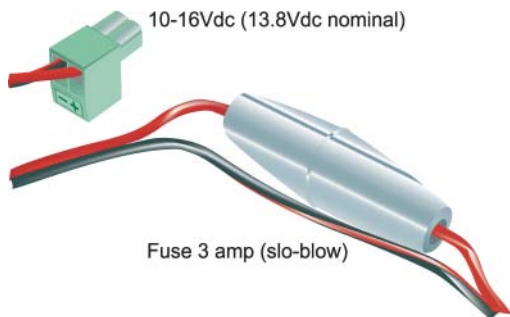

The radio is designed to self protect, and will blow the external fuse if the voltage exceeds 16Vdc, or if reverse polarity is applied.

The radio modem can also be damaged if there is any potential difference between the chassis-ground, RS232 signal ground, power (-) input, or antenna coaxial shield. Before connecting any wiring, ensure all components are earthed to a common ground point (please pay particular attention to 24V PLC power systems where converters are used).

Connect the antenna and RS 232 plugs BEFORE applying power to the unit.

Lastly, before inserting the power plug, please **re-check** that the polarity and voltage on the power plug is correct using a multimeter.

TVIEW+ Management Suite

Radio Configuration

This TVIEW+ Management Suite allows a number of features including: Configuration (Local - serial, or Remote - over-the-air), Remote Diagnostics Facilities and Firmware Upgrades.

The configuration wizard can be used to provide Quick Start generic templates for the types of systems architecture you wish to employ.

Example: Local configuration session –

- 1 Attach the programming cable from the PC to the System Port of the radio
- 2 Launch TVIEW+ & Select "Programmer"
- 3 Select "Read" the radio
- 4 Change the configuration as required
- 5 Select "Write" the parameters back to the radio

Refer to Parts I & J – TVIEW+ Management Suite for detailed operation of advanced features.

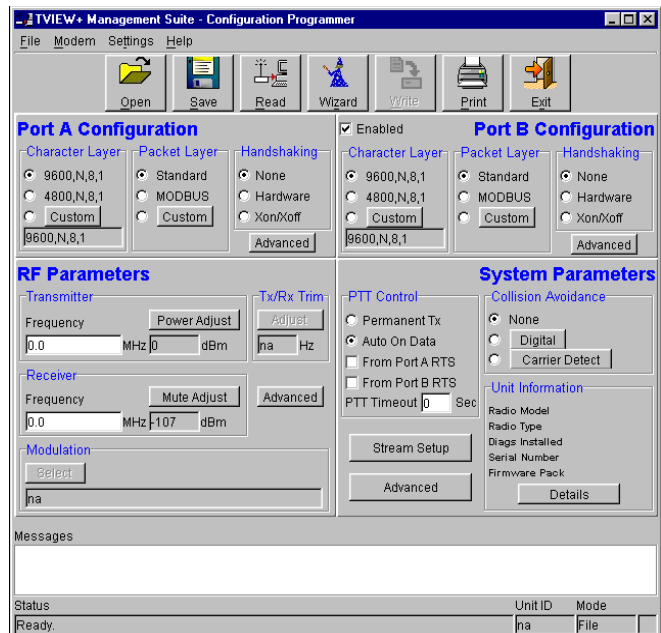
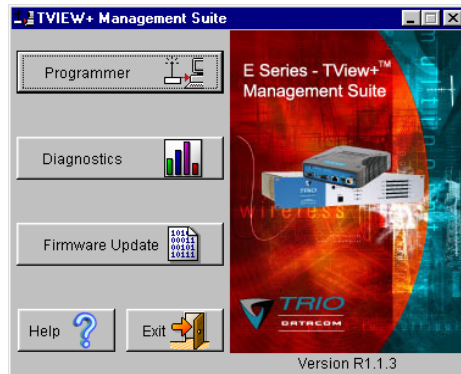

Optimising the Antenna for VSWR and best RX signal

Once the unit is operational, it is important to optimise the antenna tuning.

In the case of a directional antenna, it will be necessary to align the antenna for the best received signal.

This can be done by using the (0-5Vdc) output on Pin 9 of Port B to indicate signal strength (RSSI). This voltage can be converted to dBm using the chart below.

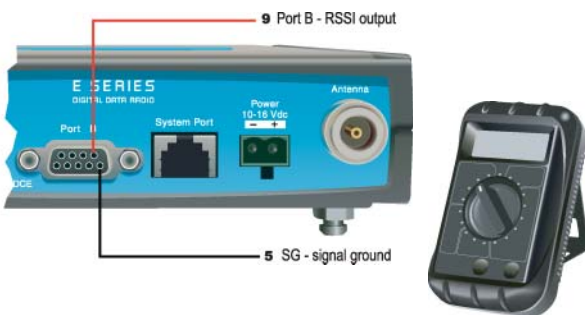

VSWR testing is achieved by activating the radio's transmitter using:

- a) An RTS loop
- b) A system port PTT plug

See Part G - Commissioning for further details.

LED Indicators & Test Outputs

Radio is Powered

If all the LEDs are off, no power is reaching the radio modem.

Successful power-up is indicated by the "PWR" LED indicating a continuous (healthy) GREEN state. Note that this LED is turned RED when the transmitter is active.



Voltage Error

If the voltage is too high (>16Vdc) or too low (<10Vdc), an error message will be displayed on the status LED's by illuminating all four LED's RED.

Hardware Error

A hardware error is indicated on any one of the status LED's by illuminating solid RED. In the case of a hardware error, the unit must be returned to the service point for repair. Record the result with the service return information.

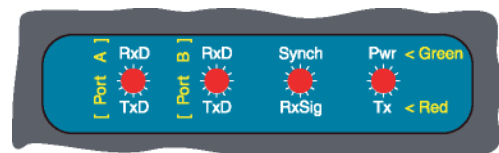

LED Legend



Received Signal Indicator

The “RX/SYNC” LED is used to indicate the state of the receiver.

If the LED is off, no signal is being received.

A RED indication shows that an RF carrier is being received, but no data stream can be decoded. This will briefly happen at the very start of every valid received transmission or may indicate the presence of interference, or another user on the channel.

A continuous GREEN indication shows that the modem is locked and synchronised to the incoming signal, and has excellent Bit Error Rate (BER). Any losses of synchronisation (BER errors) are shown as a visible RED flicker of the LED.

Note: This might only be apparent on a PTMP slave when only receiving.

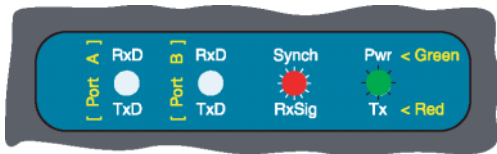
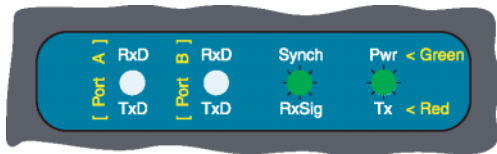

Data Flow “breakout” LEDs

There are also two LEDs to indicate data flow into and out of the two user ports.

Input data to be transmitted is shown as a RED flash, and received data to be output to the port is shown as a GREEN flash.

If data is alternately flowing in and out quickly, then the indicator appears orange.

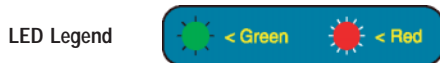

Verifying Operational Health

It is possible to verify the operation of the radio modem using the indicators provided by the unit. The state of the transmitter and receiver, and data flow can be interpreted by the indicator LEDs (see below).

Note: Port A and Port B's RxD and TxD will be Active on Data Flow

Full Duplex – PTP Master or Slave

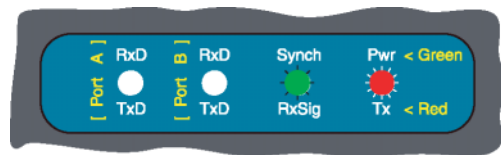

Full Duplex – PTMP Master Tx

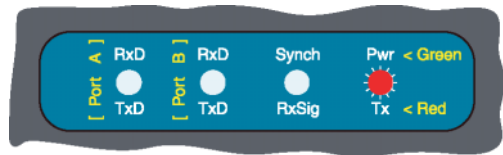

Half Duplex – PTMP Slave Rx

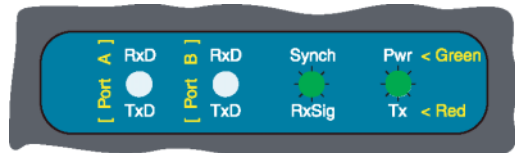

Half Duplex – Master or Slave (Tx)

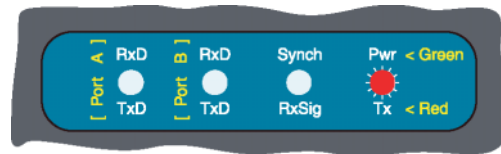

Half Duplex – Master or Slave (Rx)



EB450 Quick Start Guide

Introduction

Welcome to the *Quick Start Guide for the EB450 Base / Repeater Data Radio*. This guide provides step-by-step instructions, with simple explanations to get you up-and-running.



Mounting and Environmental Considerations

The EB450 Base Station is housed in a 2RU 19" rack enclosure. The 4 mounting holes on the front panel should be used to secure the unit to the rack.

The radio should be mounted in a clean and dry location, protected from water, excessive dust, corrosive fumes, extremes of temperature and direct sunlight. Please allow sufficient passive or active ventilation to allow the radio modem's heatsink to operate efficiently.

All permanent connections are made at the rear of the unit. This includes: Power, Antenna, Communications Ports, Digital I/O and System Port. The front panel has an additional System Port connection point for easy access.

Full Duplex Considerations

The EB450 is designed for continuous full duplex transmission. An automatic thermostatically controlled fan will operate whenever the internal temperature exceeds 50 degrees Celsius.

External Duplexer Considerations

The EB450 is normally supplied with separate Tx and Rx ports for connection to an external duplexing system.

Depending on the frequency band of operation and the Tx/Rx frequency split, internal band reject duplexers are available.

Typical Radio Setup

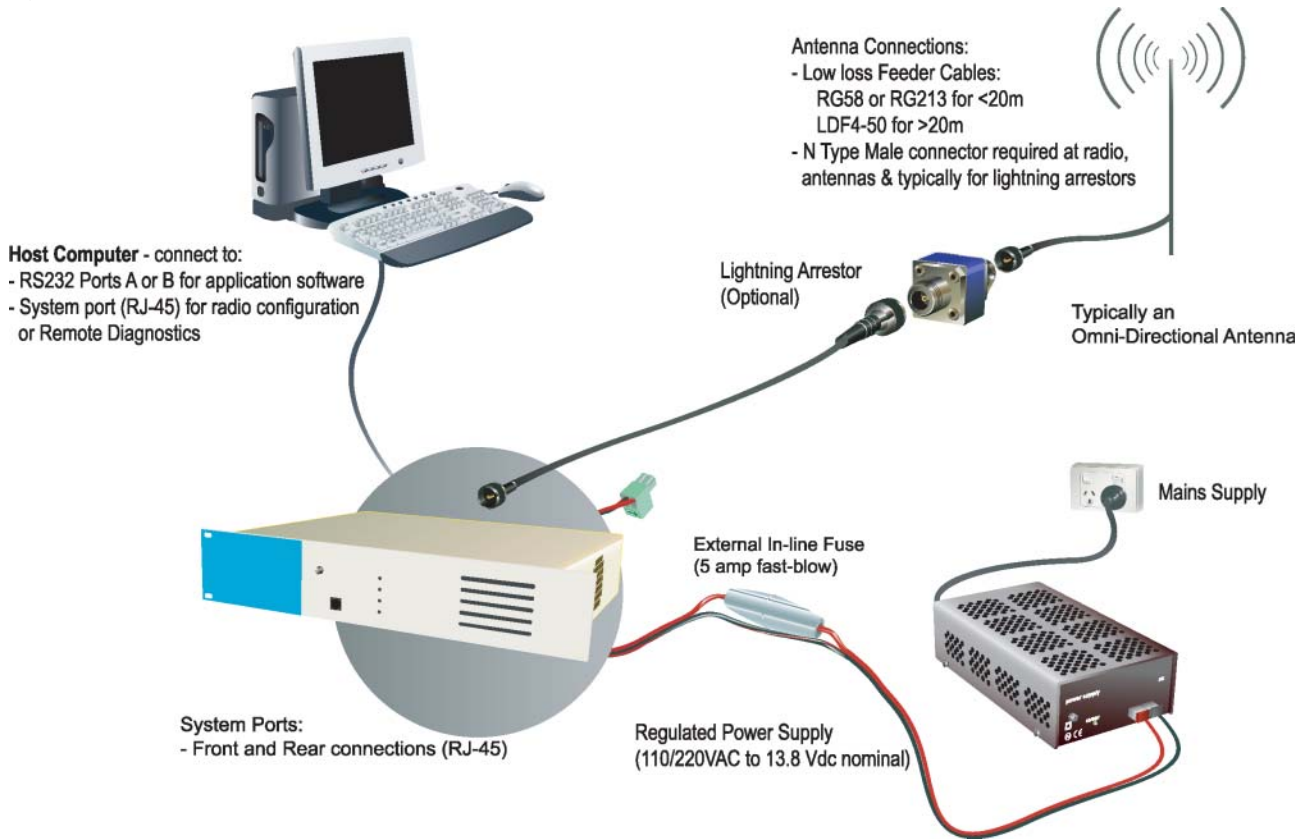

Connecting Antennas and RF Feeders

See ER450 Quick Start Guide

Communications Ports

See ER450 Quick Start Guide Section

Power Supply and Protection

See ER450 Quick Start Guide Section

TVIEW+ Management Suite - Radio Configuration

See ER450 Quick Start Guide Section

Optimising the Antenna for VSWR and best RX signal

See ER450 Quick Start Guide Section

LED Indicators & Test outputs

Radio is Powered

If all the LEDs are off, no power is reaching the radio modem.

Successful power-up is indicated by the “PWR” LED indicating a continuous (healthy) GREEN state. Note that this LED is turned RED when the transmitter is active.

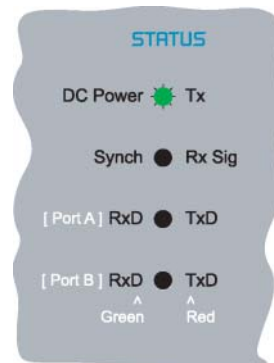

LED Legend



Voltage Error

If the voltage is too high(>16Vdc) or too low(<10Vdc), an error message will be displayed on the status LED's by illuminating all four (4) LED's RED.

Hardware Error

A hardware error is indicated on any one of the status LED's by illuminating solid RED. In the case of a hardware error, the unit must be returned to the service point for repair. Record the result with the service return information.

Received Signal Indicator

The "RX/SYNC" LED indicates the state of the receiver.

If the LED is off, no signal is being received.

A RED indication shows that an RF carrier is being received, but no data stream can be decoded. This will briefly happen at the very start of every valid received transmission or may indicate the presence of interference, or another user on the channel.

A continuous GREEN indication shows that the modem is locked and synchronised to the incoming signal, and has excellent Bit Error Rate (BER). Any losses of synchronisation (BER errors) are shown as a visible RED flicker of the LED.

Note: This might only be apparent on a PTMP slave when only receiving.

Data Flow "breakout" LEDs

There are also two LEDs to indicate data flow into and out of the two user ports.

Input data to be transmitted is shown as a RED flash, and received data to be output to the port is shown as a GREEN flash.

If data is alternately flowing in and out quickly, then the indicator appears orange.

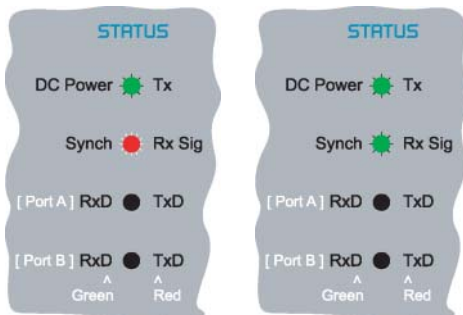

Bar Graph Indicators

The bar graph indicators on the front panel provide variable information regarding the performance of the Base Station. To enable / disable the bar graph display depress the Display ON / OFF button. The display will turn off automatically after 5 minutes.

DC Supply:

Indicates the supply input voltage at the exciter module. Typically 13.8Vdc.

Indication: <10Vdc no LED's on, 10-10.9Vdc LED's RED, 11-15.6Vdc All LED's GREEN, >=15.7Vdc last LED RED.

Tx Power:

Indicates forward RF power output as measured at the TX antenna port. Typically +37dBm.

Indication: <20dBm no LED's on, 20-40.6dBm (11.5W) LED's GREEN, >=40.7dBm last LED RED.

Tx Drive:

Indicates exciter drive level. Typically +20dBm.

Indication: <10dBm no LED's on, 10.0-25.9dBm LED's GREEN, >=26.0dBm last LED RED.

Rx Sig:

Indicates receive signal strength. Typically -85 to -65dBm.

Indication: <-120dBm no LED's on, -120 to -110.1dBm LED's RED, >=-110dBm LED's GREEN.

RxFreq. Offset:

Indicates offset of receiver AFC - useful in determining frequency drift. Typically 0kHz.

Indication: Single GREEN LED to indicate current value, <-3.6kHz or >+3.6kHz LED is RED. No signal, all LED's OFF. Note: 5 second peak hold circuitry.



Test Mode

The Bar Graph indicators have a Test Mode, which cycles all LED's for correct operation (before returning to their normal operation). To activate this mode, simply depress the ON / OFF button while applying power to the unit.

EH450 Quick Start Guide

Introduction

Welcome to the *Quick Start Guide for the EH450 Hot Standby Base / Repeater Station*. This section provides additional step-by-step instructions to install, commission and operate the EH450 Hot Standby Base Station. This document should be read in conjunction with the EB450 Base Station Quick Start Guide.

The EH450 is a fully redundant, hot standby digital data radio base / repeater station providing automatic changeover facilities.

The EH450 is designed as a modular solution, comprising 2 identical EB450 base station units (standard) linked to a central, fail-safe monitoring and change-over controller (Hot Standby Controller). Either base station may be taken out for maintenance without the need for any system down time. The automatic change-over is triggered by out of tolerance (alarm) conditions based on either RF and/or user data throughput parameters.

Features and Benefits

- Individual and identical base stations with separate control logic changeover panel
- Modules are hot swappable without user downtime
- Flexible antenna options – single, separate Tx & Rx, two Tx and two Rx
- Increased sensitivity with receiver pre-amplifier
- Both on-line and off-line units monitored regardless of active status
- External input for higher stability 10MHz reference – GPS derived
- Also refer to the common Features and Benefits list of the E Series Data Radio



Base / Repeater Unit



Hot Standby Controller Unit



Base / Repeater Unit

NOTE: RF connectors not used or ETSI version

Rear View



Operational Description

The Hot Standby Controller (HSC) unit is a 1RU rack mounted module that interfaces to two physically separate base stations (each 2RU rack mounted modules) via a number of RF and data cables.

Both base stations are operating simultaneously and both units are constantly receiving signals, however only data from one base station, the “online” base station is directed to the user equipment. The online base station is the only base station transmitting at any time.

The Hot Standby Controller has the following functions:

- Diplex the transmit and receive paths (Assuming internal duplexer fitted), TX Only.
- Amplify and split the incoming signal two ways so both base stations receive at once.
- Monitor status reports from both base stations to identify faults and swap over the online base station if required.
- Switch the antenna via internal coaxial relay duplexer to the online base station transmitter and inhibit the offline base station from transmitting.
- Switch the User A and B data ports through to the online base station.

An optocoupler based switch in the base station controller directs data to and from ports A and B on the rear panel directly to ports A and B on the on-line base station without any involvement from the Hot Standby controller microcontrollers (apart from selecting the on-line base). This provides protection of the system from failure of the microcontroller.

As well as ports A and B, each base has a system port. The system port of each base station is interfaced to the microcontroller on the Hot Standby controller. This allows the microcontroller in charge of selecting the base station to receive diagnostic messages from each base station to decide their health.

The base station has it's own system port on the rear panel and this is interfaced to the Hot Standby Contruller Module. The HSC will route diagnostics at the rear panel system port to and from the system ports of the base stations.

Mounting and Environmental Considerations

The EH450 Hot Standby Base Station is housed as a 5RU 19" rack mounted set, encompassing 2 x 2RU Base Station units and 1 x 1RU Hot Standby Controller unit. The mounting holes on the front panels should be used to secure the units to the rack.

The unit should be mounted in a clean and dry location, protected from water, excessive dust, corrosive fumes, extremes of temperature and direct sunlight. Please allow sufficient passive or active ventilation to allow the radio modem's heatsink to operate efficiently.

All permanent connections are made at the rear of the unit. This includes: Power, Antenna, Communications Ports, Digital I/O and System Port. The front panel has an additional System Port connection point for easy access.

The Base Station front panel system ports must not be used while in this config.

Communications Ports

The A & B Data Ports and System Ports of each Base Station connect directly to the Hot Standby Controller units corresponding ports with the cables provided. Ensure all clamping screws on the Data Port cables are firmly secured and the System Port cables are clipped in correctly. See figure below for further details.

Note: Only the front or rear User System Port can be used at any one time on the HSC.

Note: RF Connectors not used for ETSI version

The Hot Standby Controller units A & B Data Ports connect directly to you application device and the System Port connects directly to your local PC. See ER450 Quick Start Guide Section for further details.

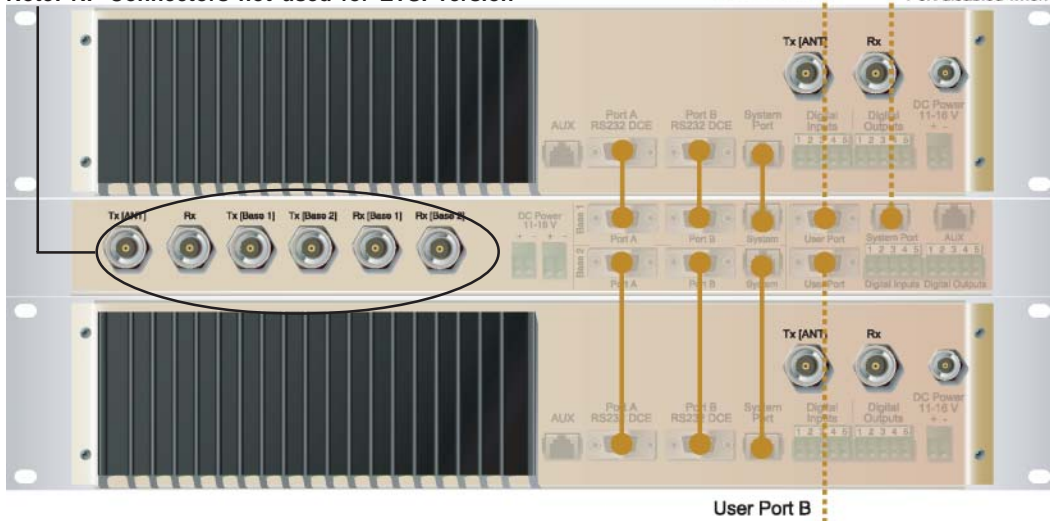

Power Supply and Protection

The EH450 has facilities for dual power supplies to provide for a redundant system. A separate power supply should be used for each of the Base Station units. The Hot Standby Controller unit has connections for dual power supplies and it is recommended that the power supplies from each of the Base Stations also be used to power the Hot Standby Controller unit. See Figure below for further details.

See ER450 Quick Start Guide Section for detailed wiring information.

Note: RF Connectors not used for ETSI version

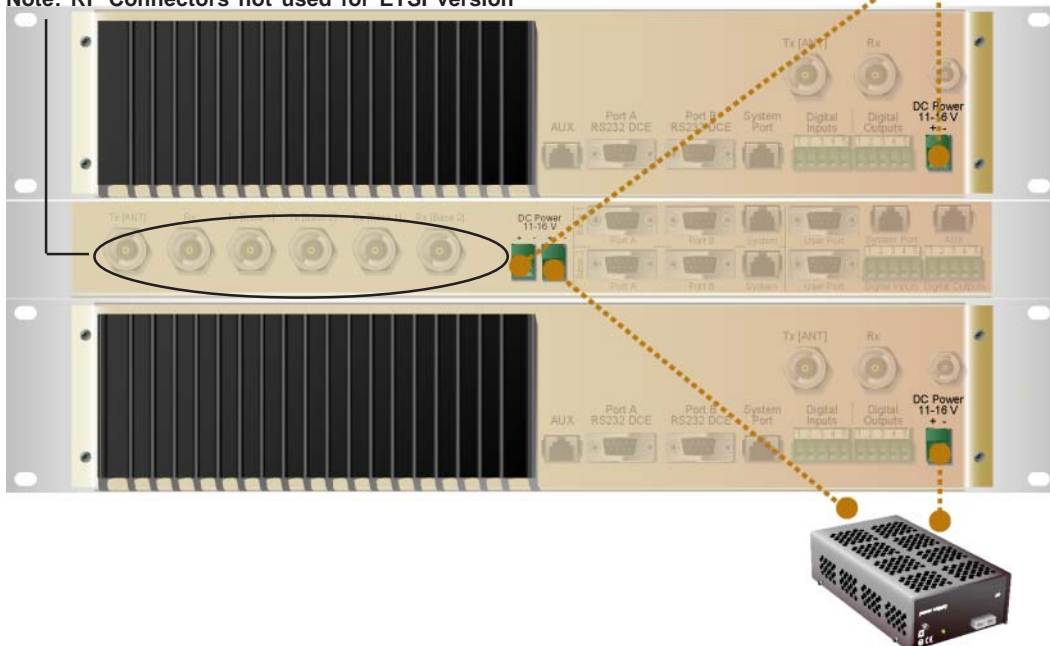

Connecting Antennas and RF Feeders

There are 3 primary antenna connection options. All connectors used are standard N Type sockets. See figures below for further details.

See ER450 Quick Start Guide for detailed wiring information.

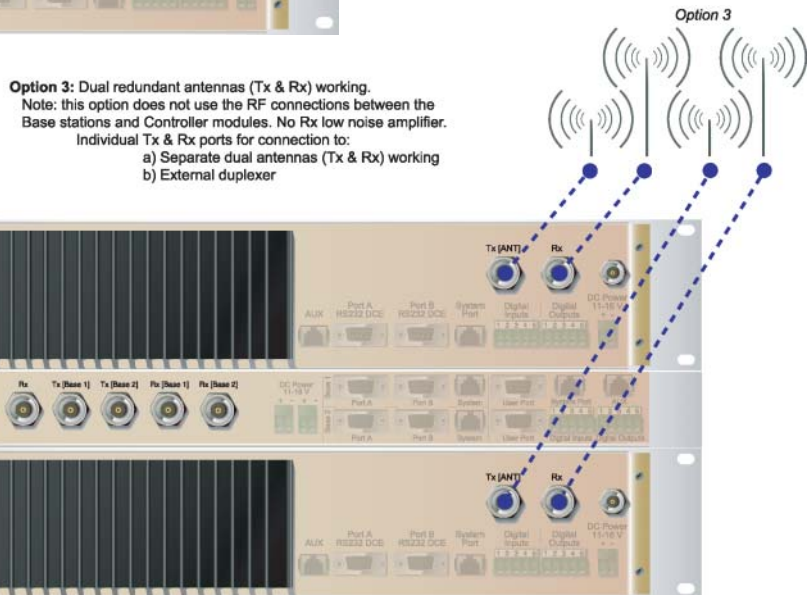
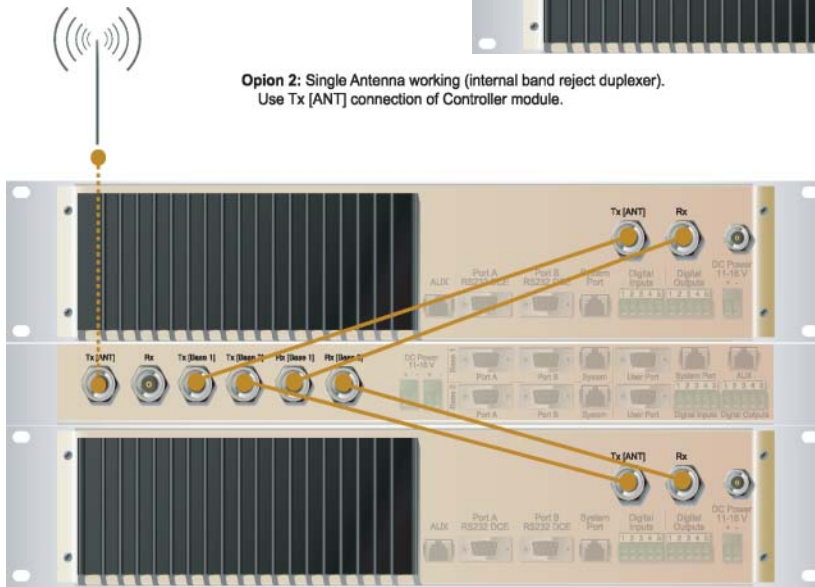
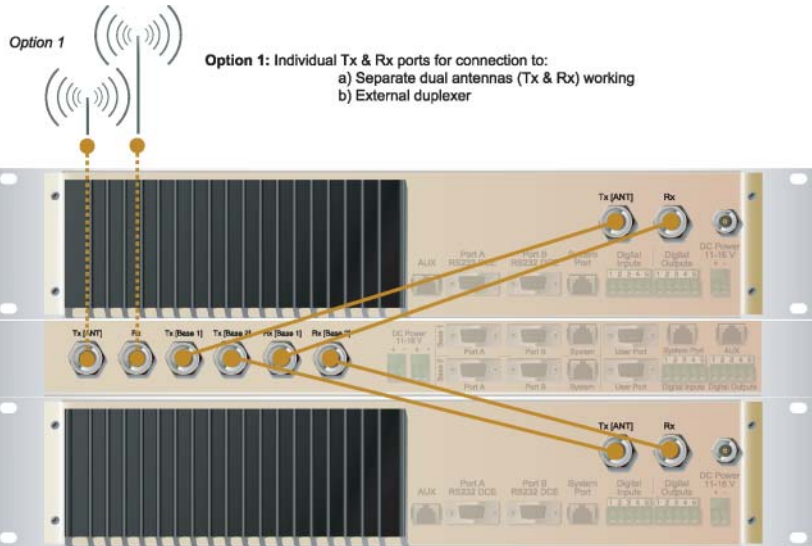

Front Panel Operation



Switches

Select Switch

The 3 position switch (1 / Auto / 2) on the front panel provides the following functionality:

- Position 1: base station 1 is forced into operation
- Position Auto: changeover hardware will select the online base station
- Position 2: base station 2 is forced into operation

The select switch is also used to identify the target base station for configuration programming.

Adjacent to the select switch are two LEDs: These LEDs indicate the current active base station.

Select LED's

- Green - Auto Mode
- Red - Remote Force
- Amber - Local Force

2 Green Firmware Download

2 Amber Test Mode

2 Red Fatal Error - refer user manual

Reset Switch

This is a momentary close switch which when depressed will reset all LED alarm indications.

System Port

There are two system port connection points, one on the rear panel and one on the front panel. Both have the same functionality and can be used for local diagnostics, firmware front panel downloads and hot standby controller testing. To access the system port use the diagnostic/programming cable supplied.

Note: When connection is made to front panel system rear system port is disabled.

Alarm Status LEDs

There are 10 alarm LEDs on the front panel, five for base 1 and five for base 2. These LEDs provide a general indication of base station status. More detailed base station status information is available by using the diagnostic utility software.

The indicated alarms for each base station are:

Freq.	=>	Frequency Error
RxSig	=>	Receive Signal (RF) Error
Data	=>	Receive Data Error
TxPower	=>	Transmit Power (RF) Error
Supply	=>	DC Voltage Error

The status of each alarm is represented as follows:

Green	=>	No Error
Red	=>	Current (active) Error condition
Amber	=>	Recovered Error condition

Any active or recovered error LEDs will turn to green after the reset alarms switch has been pushed or remotely reset.