



**TRITON™**  
NETWORK SYSTEMS, INC.

# **Invisible Fiber™ Unit Installation Guide**

for 28 GHz SONET OC-3 Applications

© 1999 Triton Network Systems, Inc. All Rights Reserved.

This document and the information contained therein is the proprietary and confidential information of Triton Network Systems, Inc. that is provided by Triton Network Systems exclusively for evaluating the purchase of Triton Network Systems, Inc. technology and is protected by copyright and trade secret laws.

No part of this document may be disclosed, reproduced, or transmitted in any form or by any means, electronic or mechanical, for any purpose without express written permission of Triton Network Systems, Inc., 8529 SouthPark Circle, Orlando, FL 32819.

For permissions, contact marketing at +1-407-903-0975 or +1-407-903-0997 (FAX).

## **Notice of Disclaimer**

The information and specifications provided in this document are subject to change without notice.

The Warranty(s) that accompany Triton Network Systems, Inc., products are set forth in the sales agreement/contract between Triton Network Systems, Inc., and its customer. Please consult the sales agreement for the terms and conditions of the Warranty(s) provided by Triton Network Systems, Inc. To obtain a copy of the Warranty(s), contact Triton Network Systems, Inc., the Marketing Group at +1-407-903-0975 or +1-407-903-0997 (FAX).

The information provided in this Triton Network Systems, Inc., document is provided “as is” without warranty of any kind, either expressed or implied, including, but not limited to, the implied warranties of merchantability, fitness for a particular purpose, or non-infringement. Some jurisdictions do not allow the exclusion of implied warranties, so the above exclusion may not apply to you.

In no event shall any Triton Network Systems, Inc., company be liable for any damages whatsoever—including special, indirect, consequential or incidental damages or damages for loss of profits, revenue, use, or data whether brought in contract or tort, arising out of or connected with any Triton Network Systems, Inc., Document or the use, reliance upon or performance of any material contained in or accessed from this Triton Network Systems, Inc. document. Triton Network Systems’ license agreement may be provided upon request. Additional Terms and Conditions will be finalized upon negotiation of a purchase.

## **Trademark Information**

Invisible Fiber™ is a trademark of Triton Network Systems, Inc.

All other brand or product names are trademarks or registered trademarks of their respective companies or organizations.

Part Number: 5036001-0002



# Contents

<b>List of Figures .....</b>	<b>vii</b>
<b>List of Tables .....</b>	<b>ix</b>
<b>About This Book .....</b>	<b>xi</b>
Purpose of This Book .....	xi
Intended Audience .....	xi
Format of This Book .....	xii
Conventions Used in This Book .....	xii
Contacting Triton Network Systems, Inc. ....	xiii
<b>Warnings and Safety Guidelines .....</b>	<b>xv</b>
Conventions .....	xv
Risk of Personal Injury from Electrical Shock .....	xvi
Risk of Personal Injury from Fiber Optics .....	xvi
Risk of Personal Injury from Radio Frequency Energy Exposure .....	xvi
Other Risks of Personal Injury .....	xvii
Risk of Service Interruption .....	xviii
Other Precautions .....	xix
<b>Avertissements et consignes de sécurité .....</b>	<b>xxi</b>
Conventions .....	xxi
Risque de lésions corporelles provoquées par la décharge électrique .....	xxii
Risque de lésions corporelles provoquées par les câbles à fibres optiques .....	xxii

---

Risque de lésions corporelles provoquées par l'exposition de l'énergie radiofréquences .....	xxiii
Autres risques des lésions corporelles .....	xxiii
Risque d'interruption de service .....	xxiv
Autres mises en garde .....	xxv
<b>Chapter 1 — Installation Overview .....</b>	<b>1-1</b>
Installation Overview .....	1-1
Site Engineering Folder .....	1-1
IFU Link Manager .....	1-2
Power Source .....	1-2
Cabling .....	1-2
Power Cable .....	1-2
Fiber Optic Cable .....	1-2
System Grounding and Surge Protection .....	1-3
Earth Ground .....	1-3
Surge Protection .....	1-3
<b>Chapter 2 — Staging Procedure .....</b>	<b>2-1</b>
Configuring IFUs .....	2-1
<b>Chapter 3 — Installation Procedures .....</b>	<b>3-1</b>
Setup .....	3-2
Before Starting .....	3-2
Preparing for Installation .....	3-2
Installing IFU Components .....	3-3
Mounting the IFU Bracket .....	3-3
Installing Power Cables .....	3-5
IFU Power Cable Test .....	3-7
Installing the Fiber Optic Cable .....	3-9
Fiber Optic Continuity Test .....	3-14
Installing an IFU .....	3-18
Mounting the IFU .....	3-18
Attaching IFU Cables .....	3-21

---

<b>Chapter 4 — Commissioning Procedures .....</b>	<b>4-1</b>
Setup .....	4-2
Before Starting .....	4-2
Preparing for Installation .....	4-2
Aligning the IFU .....	4-3
Commissioning the IFU .....	4-6
SONET OC-3 Link Performance Test .....	4-8
<b>Chapter 5 — Removing an IFU .....</b>	<b>5-1</b>
Servicing an IFU .....	5-2
Removing an IFU .....	5-2
Removing Cables .....	5-2
Removing an IFU from a Mounting Bracket .....	5-4
Packing the IFU for Shipment .....	5-5
<b>Appendix A — IFU Test Results .....</b>	<b>A-1</b>
Power Source Tests .....	A-1
SONET OC-3 Fiber Optic Test .....	A-2
Far-End Test .....	A-2
Near-End Test .....	A-2
SONET OC-3 Link Performance Test .....	A-3
<b>Invisible Fiber™ Product Glossary .....</b>	<b>glossary-1</b>
<b>Index .....</b>	<b>index-1</b>

---



# List of Figures

<b>Figure 1-1.</b>	SONET OC-3 Fiber Optic Cable Configuration .....	1-4
<b>Figure 2-1.</b>	IFU Lifting Guideline .....	2-3
<b>Figure 2-2.</b>	IFU Power Cable Hookup .....	2-4
<b>Figure 2-3.</b>	Power Test Setup .....	2-4
<b>Figure 2-4.</b>	IFU Configuration Setup .....	2-6
<b>Figure 3-1.</b>	Example of IFU Bracket Attached to Wall .....	3-3
<b>Figure 3-2.</b>	Example of IFU Bracket Attached to Pole .....	3-4
<b>Figure 3-3.</b>	Typical Power Cable Wiring .....	3-6
<b>Figure 3-4.</b>	Typical IFU Power Termination Wiring Schematic .....	3-7
<b>Figure 3-5.</b>	Power Test Setup .....	3-8
<b>Figure 3-6.</b>	Demarcation Patch Panel .....	3-11
<b>Figure 3-7.</b>	Typical SONET OC-3 Site Schematic .....	3-13
<b>Figure 3-8.</b>	Typical SONET OC-3 Demarcation Jumper Locations ....	3-14
<b>Figure 3-9.</b>	SONET OC-3 Fiber Optic Continuity Test Setup .....	3-17
<b>Figure 3-10.</b>	Mounting the IFU .....	3-19
<b>Figure 3-11.</b>	IFU Cable Connections .....	3-21
<b>Figure 4-1.</b>	Coarse Alignment .....	4-3
<b>Figure 4-2.</b>	Alignment Test Setup .....	4-4
<b>Figure 4-3.</b>	SONET Link Test Setup .....	4-9
<b>Figure 5-1.</b>	IFU Cable Connections .....	5-3
<b>Figure 5-2.</b>	IFU Removal .....	5-5

---





# List of Tables

<b>Table 2-1.</b>	Typical IFU Configuration Parts List .....	2-1
<b>Table 3-1.</b>	Site Installation Tools .....	3-2
<b>Table 3-2.</b>	Site Installation Parts (for two IFUs) .....	3-2
<b>Table 3-3.</b>	Typical Power Cable Wiring .....	3-6
<b>Table 3-4.</b>	Typical SONET OC-3 Demarcation Panel Input Connections 3-12	
<b>Table 3-5.</b>	Typical SONET OC-3 Demarcation Panel Jumper Connections 3-14	
<b>Table 3-6.</b>	SONET OC-3 Fiber Test Connections .....	3-18
<b>Table 4-1.</b>	Site Commissioning Tools .....	4-2
<b>Table A-1.</b>	Power Supply Test Results .....	A-1
<b>Table A-2.</b>	SONET OC-3 Fiber Optic Test Results .....	A-2
<b>Table A-3.</b>	Far-End Test Results #1 .....	A-2
<b>Table A-4.</b>	Far-End Test Results #2 .....	A-2
<b>Table A-5.</b>	Near-End Test Results #1 .....	A-2
<b>Table A-6.</b>	Near-End Test Results #2 .....	A-3
<b>Table A-7.</b>	SONET OC-3 Link Performance Test .....	A-3





# *About This Book*

The Triton Network Systems, Inc., 28 GHz Invisible Fiber™ unit (IFU) delivers high bandwidth, high-speed traffic through a wireless transport. IFUs are configured at the factory to work with Fast Ethernet or SONET applications. This book describes the SONET OC-3 application for the IFU.

## **Purpose of This Book**

This book describes how to:

### **Configure IFUs**

Perform preparatory (prior to installation) operations on an IFU, such as downloading attributes.

### **Install IFUs**

Install the brackets, mount the IFU, and run and connect cables.

### **Commission IFUs**

Align IFUs and perform a series of tests to ensure proper operation.

### **Remove IFUs**

Servicing and removing and IFU.

The procedures include required verification tests and appropriate warning messages.

## **Intended Audience**

This book is written specifically for installation and commissioning technicians and network engineers. The book assumes that the reader has a basic understanding of installing hardware.

---

## Format of This Book

This book contains:

Book Unit	Description
<i>Warnings and Safety Guidelines</i> on page xv	Provides a list of all warning, danger, and caution messages related to working with IFUs.
Chapter 1, <i>Installation Overview</i>	Describes a typical IFU installation, the types of cables used, and power requirements.
Chapter 2, <i>Staging Procedure</i>	Provides the procedures to perform before installing the IFU.
Chapter 3, <i>Installation Procedures</i>	Provides the component installation procedures.
Chapter 4, <i>Commissioning Procedures</i>	Provides alignment and test procedures to ensure proper operation.
Chapter 5, <i>Removing an IFU</i>	Provides the procedure to remove and replace an IFU.
Appendix A, <i>IFU Test Results</i>	Provides test forms.
<i>Invisible Fiber™ Product Glossary</i>	Provides descriptions of product terminology.
<i>Index</i>	Provides an alphabetical list with the page location of information included in this book.

## Conventions Used in This Book

This book uses the following conventions:

- *Italic* - to indicate:
  - A book title
  - A heading or chapter title reference (for example, See *Conventions Used in This Book*)
  - Word emphasis (for example, *Do not* turn on the power ....)
- A *Note*: label to identify an informational note. For example:

**NOTE:** Refer to the previous chapter for more information.

For warning and safety precaution conventions, see *Conventions* on page xv (English version) or *Conventions* on page xxi (French version).

---

## Contacting Triton Network Systems, Inc.

Direct any questions to your project liaison or:

Triton Network Systems, Inc.  
Technical Assistance Center (TAC)  
8529 SouthPark Circle  
Orlando, FL 32819  
Telephone - Domestic, Toll-free: 1-877-6TRITON (1-877-687-4866)  
Telephone - International: +1-407-903-2070  
E-Mail: [support@triton-network.com](mailto:support@triton-network.com)  
FAX: +1-407-903-0995

---



# Warnings and Safety Guidelines

## Conventions

The following list identifies the warning and caution graphic symbols used in this guide:



### **Risk of Personal Injury from Electrical Shock**

This symbol indicates a risk of personal injury due to an electrical shock.



### **Risk of Personal Injury from Fiber Optics**

This symbol indicates a risk of personal injury from fiber optic cable laser radiation.



### **Risk of Personal Injury from Radio Frequency Energy Exposure**

This symbol indicates a risk of personal injury due to radio frequency energy exposure.



### **Other Risks of Personal Injury**

This symbol indicates a risk of personal injury from a source other than electrical shock, laser radiation, or radio frequency energy exposure.



### **Risk of Service Interruption**

This symbol indicates a risk of service interruption or equipment damage.

---

## Risk of Personal Injury from Electrical Shock



**DANGER – HIGH CURRENT HAZARD:** Do not turn on power before reading the Triton Network Systems' product documentation. This device has a – 48 Vdc (4 amps operating peak per feed) direct current input.

**DANGER – HIGH CURRENT HAZARD:** Ensure that the – 48 Vdc power source is set to the OFF position before beginning the installation procedures for the Invisible Fiber™ unit.

**DANGER – HIGH VOLTAGE HAZARD:** Do not work on the system or connect or disconnect cables during periods of lightning activity, rainy weather, or both.

**WARNING:** Instructions for installing cables are intended for licensed contractors or building maintenance personnel.

## Risk of Personal Injury from Fiber Optics



**DANGER:** Invisible laser radiation. Avoid direct eye exposure to the end of a fiber, fiber cord, or fiber pigtail. The infrared light used in fiber optics systems is invisible, but can cause serious injury to the eye.

**WARNING:** Never touch exposed fiber with any part of your body. Fiber fragments can enter the skin and are difficult to detect and remove.

## Risk of Personal Injury from Radio Frequency Energy Exposure



**WARNING:** Beware! Radio transmitter is ON when the red light indicator on back side of Invisible Fiber™ unit is illuminated. Observe all radio frequency energy exposure and service interruption cautions.

**WARNING – RF EXPOSURE HAZARD:** Ensure the safety of all personnel. Do not stand in front of the Invisible Fiber™ unit (antenna) in order to avoid possible harmful radio frequency energy exposure.



## Other Risks of Personal Injury

**NOTE:** The following warning and cautions are for risk of injury from sources other than electrical shock, fiber optics, or radio frequency energy exposure.



**WARNING:** This Invisible Fiber™ unit is designed to permit the connection of the earthed conductor from the DC source circuit to the earthing conductor at the Invisible Fiber™ unit. Do not switch or disconnect devices in the earthed circuit conductor between the DC source and point of connection of the earthing electrode conductor.

**WARNING:** Failure to follow operating instructions could result in death or serious injury.

**CAUTION:** Instructions for installing cables are intended for licensed contractors or building maintenance personnel.

**CAUTION:** Lifting hazard: Two people are required to lift the Invisible Fiber™ unit. Grasp the Invisible Fiber™ unit underneath the lower edge and lift with both hands. To prevent injury, keep your back straight and lift with your legs, not your back. To prevent damage to the Invisible Fiber™ unit and components, never attempt to lift the radio by the attached cables.

**CAUTION:** Keep tools and parts away from walkways. When carrying large, heavy equipment (such as the Invisible Fiber™ unit), obstacles (such as hand tools, cables or components) may not be easily visible and can cause accidents.

---

## Risk of Service Interruption



**CAUTION:** Handle the Invisible Fiber™ unit with care to avoid equipment damage.

**CAUTION:** Ensure the outside optical fiber connectors are environmentally protected. Failure to do so may cause contamination of the fiber surfaces.

**CAUTION:** The Invisible Fiber™ unit contains no owner or user serviceable parts. Opening the radio unit or tampering with any of its seals voids all warranties.

**CAUTION:** Prior to installing an Invisible Fiber™ unit, the installation site must be surveyed to assess its appropriateness or adequacy, system requirements, path analysis, signal path, and power requirements.

**CAUTION:** Instructions for installing cables are intended for licensed contractors or building maintenance personnel.

**CAUTION:** *DO NOT* lift the Invisible Fiber™ unit by the Radome (front) Cover to avoid damaging the antenna.

**CAUTION:** Ensure the mounting bracket and Invisible Fiber™ unit are installed properly according to the instructions in the Triton Network Systems' product documentation.

**CAUTION:** Ensure that the – 48 Vdc power source is set to the OFF position before attaching power cables to the Invisible Fiber™ unit.

**CAUTION:** Do not block the front of the Invisible Fiber™ unit to avoid possible radio service interruption.

**CAUTION:** To reduce the risk of fiber optic cable damage, use the following bend radius guidelines for indoor/outdoor fiber optic cable:

- Long-term (installed): bend radius is equal to 10 times the diameter of the cable.
- Short-term (during installation): bend radius is equal to 20 times the diameter of the cable.

## Other Precautions

Failure to follow the installation procedure described in the Triton Network Systems' product documentation may result in damage to the Invisible Fiber™ unit and render the unit unusable. If you have any questions, contact your Triton Network Systems' project liaison or the Technical Assistance Center at:

Triton Network Systems, Inc.  
8529 SouthPark Circle  
Orlando, FL 32819

Telephone - Domestic, Toll-free: 1-877-6TRITON (1-877-687-4866)  
Telephone - International: +1-407-903-2070  
E-Mail: support@triton-network.com  
FAX: +1-407-903-0995

The Invisible Fiber™ unit must be installed in accordance with wall-mount or pole-mount specifications described in the Triton Network Systems' product documentation.

Observe all federal and local laws, regulations, electrical codes, building codes, fire codes, and licensing agreements.

Ensure the safety of all personnel and bystanders from potential radio frequency energy exposure hazards. Observe FCC 47 CFR 1.1307 for environmental assessments, FCC 47 CFR 1.1310 for radio frequency exposure limits, Health Canada Safety Code 6 for limits to exposure to RF fields, and other relevant regulatory and safety compliance rules for proper safety procedures, training, and assessment.

Ensure that appropriate warning signs are properly placed and posted at the equipment site or access entry.

Changes or modifications to this unit not expressly approved by the party responsible for compliance could void the user's authority to operate the equipment.

The equipment has been tested and found to comply with the limits for a Class B digital device, pursuant to part 15 of the FCC rules. These limits are designed to provide reasonable protection against harmful interference in residential installations. This equipment generates, uses, and can radiate radio frequency energy, and if not installed and used in accordance with the instructions, may cause harmful interference to radio communications. However, there is no guarantee that interference will not occur in a particular installation. If this equipment does cause harmful interference to radio or television reception, which can be determined by turning the equipment off and on, the user is encouraged to try to correct the interference by performing

---

one or more of the following measures on the radio or television antenna that is affected by interference:

- Reorient or relocate the receiving antenna.
- Increase the separation between the equipment and the receiver.
- Connect the equipment to an outlet on a different circuit than the circuit the receiver is connected to.
- Consult the dealer or an experienced radio or TV technician for help.

This device complies with RSS-191 of Industry Canada. Operation is subject to the following two conditions:

- This device may not cause interference
- This device must accept any interference, including interference that may cause undesired operation of the device.

This Class B digital apparatus complies with Canadian ICES-003.



# Avertissements et consignes de sécurité

## Conventions

La liste suivante explique les symboles d'avertissement et de mise en garde utilisés dans ce guide:



### Risque de lésions corporelles provoquées par la décharge électrique

Ce symbole indique un risque de lésions corporelles provoquées par la décharge électrique.



### Risque de lésions corporelles provoquées par les câbles à fibres optiques

Ce symbole indique un risque de lésions corporelles provoquées par les câbles à fibres optiques.



### Risque de lésions corporelles provoquées par l'exposition de l'énergie radiofréquences

Ce symbole indique un risque de lésions corporelles provoquées par l'exposition de l'énergie radiofréquences.



### Autres risques de lésions corporelles

Ce symbole indique d'un risque de lésions corporelles (à part celles provoquées par la décharge électrique, par la radiation du laser, ou par l'exposition de l'énergie radiofréquences).



### Risque d'interruption de service

Ce symbole indique un risque d'interruption de service ou de dommage aux équipements.

---

## Risque de lésions corporelles provoquées par la décharge électrique



**DANGER – L'HASARD DU COURANT ÉLEVÉ :** Ne pas mettre la tension avant de lire la documentation du produit fournie par la société Triton Network Systems. Cet appareil a une alimentation directe de – 48 V CC (courant de pointe de 4 ampères par ligne d'alimentation).

**DANGER – L'HASARD DU COURANT ÉLEVÉ :** S'assurer que le bloc d'alimentation – 48 V CC est en position HORS TENSION avant d'aborder les procédures pour l'installation de l'unité Invisible Fiber<sup>MD</sup>.

**DANGER – L'HASARD DU TENSION ÉLEVÉ :** Ne pas travailler sur le système ni brancher ni débrancher les câbles durant l'activité de la foudre, par de temps pluvieux, ou tous le deux.

**AVERTISSEMENT :** Les instructions pour l'installation des câbles sont destinées exclusivement aux entrepreneurs agréés et aux préposés à l'entretien de l'immeuble.

## Risque de lésions corporelles provoquées par les câbles à fibres optiques



**DANGER :** Rayonnement laser invisible. Éviter l'exposition directe des yeux à l'extrémité d'une fibre, d'un cordon à fibres ou d'une fibre amorce. La lumière infrarouge utilisée dans les systèmes à fibres optiques est invisible, mais peut provoquer des lésions graves aux yeux.

**AVERTISSEMENT :** Ne jamais laisser une fibre nue entrer en contact avec une partie quelconque du corps. Des fragments de fibre peuvent entrer dans la peau, et sont difficiles à déceler et à enlever.

## Risque de lésions corporelles provoquées par l'exposition de l'énergie radiofréquences



**MISE EN GARDE :** Attention ! Le poste émetteur est EN MARCHE lorsque le témoin rouge sur le dos de l'unité Invisible Fiber<sup>MD</sup> est allumé. Respecter toutes les mises en garde concernant l'exposition aux radiofréquences et l'interruption de service.

**MISE EN GARDE – RF EXPOSURE HAZARD :** Assurer la sécurité de tout le personnel. Ne pas rester debout devant l'unité Invisible Fiber<sup>MD</sup> (l'antenne) afin d'éviter toute exposition dangereuse aux radiofréquences. Les lésions corporelles sérieux s'ensuivent.

## Autres risques des lésions corporelles

Les mises en garde suivantes concernent les risques de lésions corporelles attribuables à des causes autres que la décharge électrique, la radiation du laser, ou l'exposition de l'énergie radiofréquences).



**AVERTISSEMENT :** Cette unité Invisible Fiber<sup>MD</sup> permet la connexion entre le conducteur de mise à la terre du circuit d'alimentation CC et le conducteur de mise à la terre de l'unité Invisible Fiber<sup>MD</sup>. Ne pas changer ni débrancher les dispositifs qui se trouvent dans le conducteur du circuit mis à la terre entre la source de l'énergie CC et le point de connexion au conducteur de l'électrode de prise de terre.

**AVERTISSEMENT :** Ne pas suivre les instructions d'utilisation peut causer de sérieuses blessures et même la mort.

**MISE EN GARDE :** Les instructions pour l'installation des câbles sont destinées exclusivement aux entrepreneurs agréés et aux préposés à l'entretien de l'immeuble.

**MISE EN GARDE :** Danger de levage. Il faut deux personnes pour soulever l'unité Invisible Fiber<sup>MD</sup>. Saisir l'unité Invisible Fiber<sup>MD</sup> au-dessous du rebord inférieur, puis soulever l'unité avec les deux mains. Pour éviter les lésions corporelles, garder le dos en position verticale et soulever l'unité en utilisant les jambes et non pas les reins. Pour éviter l'endommagement de l'unité Invisible Fiber<sup>MD</sup> et de ses composants, ne jamais essayer de soulever la radio en tirant sur les câbles qui y sont attachés.



**MISE EN GARDE :** Garder les outils et les pièces loin des allées. Lorsqu'on transporte des équipements lourds et à grandes dimensions (tels que l'unité Invisible Fiber<sup>MD</sup>), les obstacles (tels que les outils à main, les câbles ou les composants) sont parfois difficiles à voir et peuvent causer des accidents.

## Risque d'interruption de service



**MISE EN GARDE :** Manipuler l'unité Invisible Fiber<sup>MD</sup> avec soin pour éviter des dommages aux équipements.

**MISE EN GARDE :** S'assurer que les raccords extérieurs fibre optique sont protégés contre l'environnement. L'absence d'une telle protection peut entraîner la contamination des surfaces des fibres.

**MISE EN GARDE :** L'unité Invisible Fiber<sup>MD</sup> contient pas de parts utilisés par le propriétaire ou l'utilisateur. Ouverture de l'unité de la radio ou toucher aux scelles rend toute garantie nulle et non avenue.

**MISE EN GARDE :** Avant d'installer une unité Invisible Fiber<sup>MD</sup>, il faut vérifier que les lieux de l'installation sont convenables et adéquats, déterminer les besoins du système, analyser les trajets, préciser le parcours du signal et déterminer les exigences en matière d'énergie.

**MISE EN GARDE :** Les instructions pour l'installation des câbles sont destinées exclusivement aux entrepreneurs agréés et aux préposés à l'entretien de l'immeuble.

**MISE EN GARDE :** *NE PAS* soulever l'unité Invisible Fiber<sup>MD</sup> par le couvercle du radôme (couvercle avant), afin d'éviter l'endommagement de l'antenne.

**MISE EN GARDE :** S'assurer que le support de montage et l'unité Invisible Fiber<sup>MD</sup> sont installés convenablement, selon les instructions figurant dans la documentation du produit fournie par la société Triton Network Systems.

**MISE EN GARDE :** S'assurer que le bloc d'alimentation – 48 V CC est en position HORS TENSION avant d'attacher les câbles d'alimentation à l'unité Invisible Fiber<sup>MD</sup>.

**MISE EN GARDE :** Ne pas bloquer le devant de l'unité Invisible Fiber<sup>MD</sup>, pour éviter toute interruption éventuelle du service de transmission radio.





**MISE EN GARDE :** Pour réduire le risque de dommage aux câbles à fibres optiques, suivre les consignes suivantes en matière de rayon de courbure des câbles à fibres optiques extérieurs ou intérieurs :

- Courbure à long terme (installée). Le rayon de courbure ne doit pas dépasser 10 fois le diamètre du câble.
- Courbure à court terme (pendant l'installation). Le rayon de courbure ne doit pas dépasser 20 fois le diamètre du câble.

## Autres mises en garde

L'observation de la procédure d'installation décrite dans la documentation du produit fournie par la société Triton Network Systems peut endommager l'unité Invisible Fiber<sup>MD</sup> et la rendre inutilisable. Si vous avez des questions à poser, veuillez communiquer avec votre agent de liaison des projets chez Triton Network Systems, ou bien joindre notre Centre d'assistance technique à l'adresse suivante :

Triton Network Systems, Inc.  
8529 SouthPark Circle  
Orlando, FL 32819  
Téléphone - Aux États-Unis, sans frais : 1-877-6TRITON (1-877-687-4866)  
Téléphone - Dans d'autres pays : +1-407-903-2070  
Internet : support@triton-network.com  
Télécopieur : +1-407-903-0995

Il faut installer l'unité Invisible Fiber<sup>MD</sup> selon la spécification pour le montage mural ou sur poteau, telle que précisée dans la documentation du produit fournie par la société Triton Network Systems.

Il faut respecter l'ensemble des lois, règlements, codes d'électricité, codes du bâtiment et codes des incendies du gouvernement fédéral et des municipalités ainsi que tous les contrats de licence.

Assurez la sécurité de toute les personnels et les autres autour, contre l'hasard d'exposition de l'énergie des radiofréquences. Observez FCC 47 CFR 1.1307 pour l'appréciation de l'environnement, FCC 47 CFR 1.1310 pour les limitations d'exposition des radiofréquences, Code 6 de Sécurité de Santé Canada pour la limite d'exposition aux champs RF, et les autre règlements alliés et de complaisance de la sécurité pour les procédures appropriées de la sécurité, de l'apprentissage, et de l'appréciation.

Assurez que le signals d'avertissement appropriés soivant placés appropriatement et affichés dans la location d'équipement ou l'accès d'y entrer.

---

Cet appareil est conforme au RSS-191 de Industrie Canada. L'utilisation dépend des deux conditions suivantes:

- Cet appareil ne devrait pas causer d'interférence.
- Cet appareil doit accepter toute interférence, y compris une interférence pouvant causer une opération indésirable de l'appareil.

Cet appareil numérique de la classe B est conforme avec la norme NMB-003 du Canada.

DRAFT  
DO NOT COPY



# Installation Overview

This chapter provides an overview of the installation procedure for the Invisible Fiber™ unit (IFU). In addition, this chapter describes:

- IFU Link Manager
- Power source
- Cables
- System grounding and surge suppression

## Installation Overview

IFUs are loaded with default system attributes at the factory. At the customer's designated staging area, the customer-specific attributes, identified in the site database, are downloaded to the IFU, which is then ready for installation. At the installation site, the IFU is installed on a mounting bracket, aligned, and commissioned. When all installation tests are complete and expected results are achieved on all IFU sites, the network is ready for customer acceptance.

## Site Engineering Folder

Before installing the IFU, the site must be prepared with the appropriate cables, demarcation box, and any equipment as detailed in the site engineering folder. (Refer to the *Invisible Fiber™ SONET OC-3 Site Evaluation Guide* for details about the contents of the site engineering folder).

The site engineering folder is referenced throughout this document. Photos and diagrams of the site are included in the folder.

## IFU Link Manager

The IFU Link Manager is a local element management software application that helps you configure and commission the IFU. You use this application to complete the following procedures:

- IFU configuration
- Antenna alignment
- Link commissioning tests

## Power Source

The IFUs require a – 48 Vdc power source. The specifications of the power source are defined in the site engineering folder.

## Cabling

IFU installations require two types of cables:

### **Power**

Connects the IFU to the – 48 Vdc power source.

### **Fiber Optic**

Connects the IFU to the site equipment cabinet.

## Power Cable

The power cable is outdoor/indoor rated. The power cable contains four 12 AWG conductors.

## Fiber Optic Cable

For SONET networks, the IFU requires a multimode/single-mode, fiber optic cable (see Figure 1-1).

## System Grounding and Surge Protection

The IFU grounding system has two conceptually distinct, but electrically interconnected functional subsystems, for connection to “earth ground.” The two functional subsystems are:

- Earth ground (complies with the National Electrical Code (NEC) for equipment grounding systems).
- Surge protection.

### Earth Ground

The IFU has an external electrical interconnection point for connecting the IFU ground subsystems to earth ground.

### Surge Protection

The sole purpose of surge protection is to transport lightning-related currents to the earth ground. During site installation, surge suppression devices are installed inline with the power and alarm conductors to assist in protecting equipment.

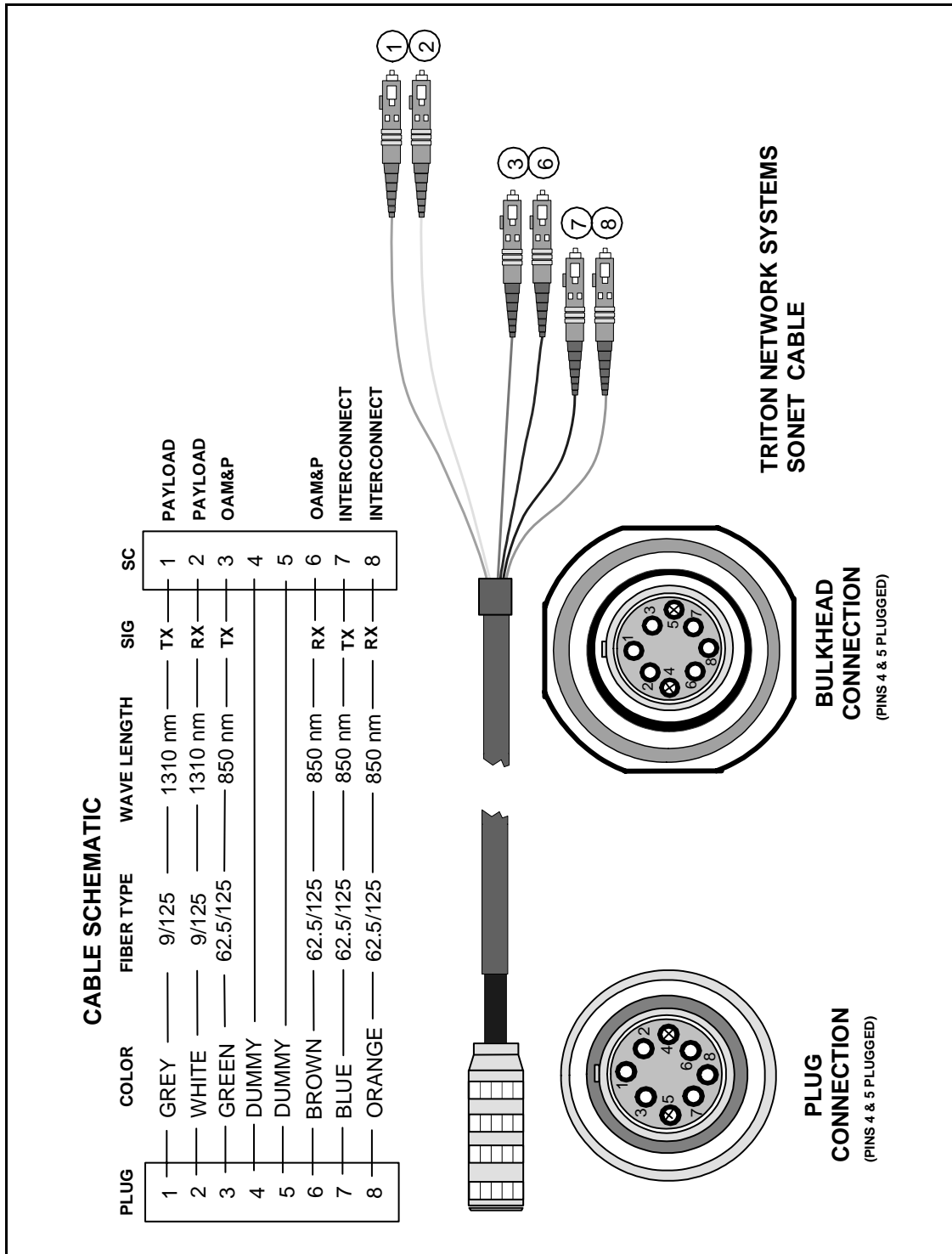

Figure 1-1. SONET OC-3 Fiber Optic Cable Configuration



# Staging Procedure

This chapter describes the IFU configuration procedure to be performed at the designated staging area.

## Configuring IFUs

IFUs are configured by using the IFU Link Manager to load the site-specific attributes from the attributes table in the site engineering folder. Table 2-1 identifies the parts needed for configuring a typical IFU site.

**Table 2-1.** Typical IFU Configuration Parts List

Item No.	Description	Qty.
1	IFU	1
2	BNC to banana plug adapter	1
3	IFU Link Manager test cable	1
4	Laptop computer with IFU Link Manager installed	1
5	Power source (– 48 Vdc)	1
6	IFU power cable	1
7	Site engineering folder	1
8	Digital multimeter	1

► To configure each IFU, complete the following steps:

- 1 Remove the IFU from the shipping carton and place it upright on a table with the antenna radome cover facing away from you and the connectors facing you. Verify that the part number on the IFU label matches the attributes table in the site engineering folder.

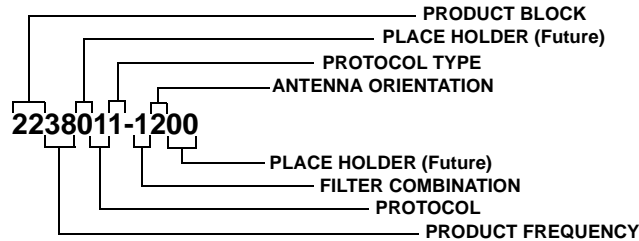

22380PT-FA00 is a sample part number, where the letters are variables defined as follows:

P = Protocol (1=SONET, 2=Ethernet)

T = Protocol type (1=OC-3, 2=OC-12, 1=Fast, 2=Gigabit)

F = Filter combination for transmit/receive (1/3=1, 2/4=2, 3/1=3, 4/2=4)

A = Antenna orientation (Vertical=1, Horizontal=2)

---

**CAUTION:** Lifting hazard: Two people are required to lift the Invisible Fiber™ unit. Grasp the Invisible Fiber™ unit underneath the lower edge and lift with both hands. To prevent injury, keep your back straight and lift with your legs, not your back. To prevent damage to the Invisible Fiber™ unit and components, never attempt to lift the radio by the attached cables.



**MISE EN GARDE :** Danger de levage. Il faut deux personnes pour soulever l'unité Invisible Fiber<sup>MD</sup>. Saisir l'unité Invisible Fiber<sup>MD</sup> au-dessous du rebord inférieur, puis soulever l'unité avec les deux mains. Pour éviter les lésions corporelles, garder le dos en position verticale et soulever l'unité en utilisant les jambes et non pas les reins. Pour éviter l'endommagement de l'unité Invisible Fiber<sup>MD</sup> et de ses composants, ne jamais essayer de soulever la radio en tirant sur les câbles qui y sont attachés.

---





**CAUTION:** *DO NOT* lift the Invisible Fiber™ unit by the Radome (front) Cover to avoid damaging the antenna.

**MISE EN GARDE :** *NE PAS* soulever l'unité Invisible Fiber<sup>MD</sup> par le couvercle du radôme (couvercle avant), afin d'éviter l'endommagement de l'antenne.

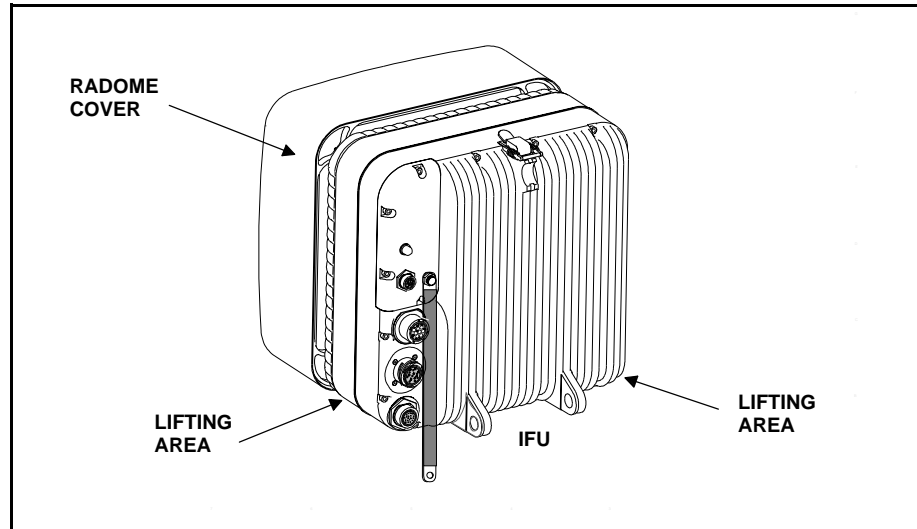

Figure 2-1. IFU Lifting Guideline

**DANGER – HIGH VOLTAGE HAZARD:** Do not work on the system or connect or disconnect cables during periods of lightning activity, rainy weather, or both.



**DANGER – L'HASARD DU TENSION ÉLEVÉ :** Ne pas travailler sur le système ni brancher ni débrancher les câbles durant l'activité de la foudre, par de temps pluvieux, ou tous le deux.

**DANGER – HIGH CURRENT HAZARD:** Ensure that the – 48 Vdc power source is set to the OFF position before beginning the installation procedures for the Invisible Fiber™ unit.



**DANGER – L'HASARD DU COURANT ÉLEVÉ :** S'assurer que le bloc d'alimentation – 48 V CC est en position HORS TENSION avant d'aborder les procédures pour l'installation de l'unité Invisible Fiber<sup>MD</sup>.

- 2 Connect the IFU power cable to the – 48 Vdc power source as shown in Figure 2-2.

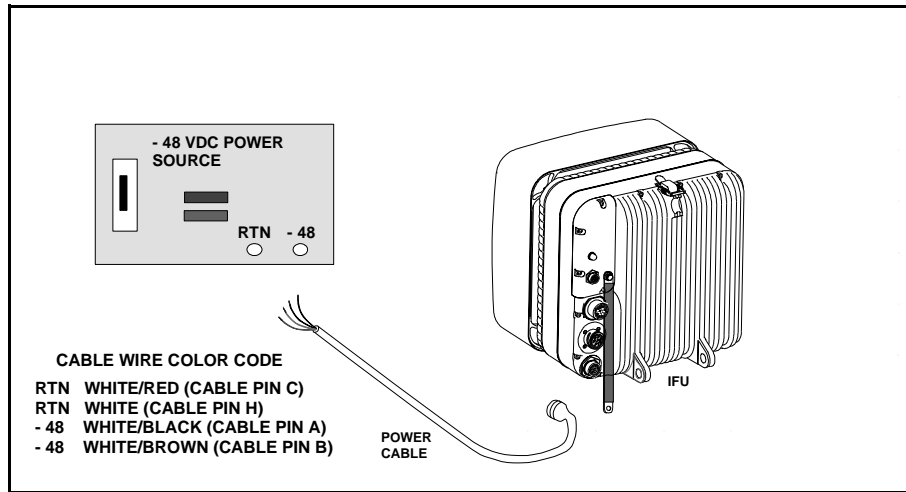

Figure 2-2. IFU Power Cable Hookup

- 3 Set the – 48 Vdc power source to ON.
- 4 Set multimeter to DC voltage.
- 5 Connect a black test lead from the **negative** input of the multimeter to pin C on the IFU power cable (see Figure 2-3).

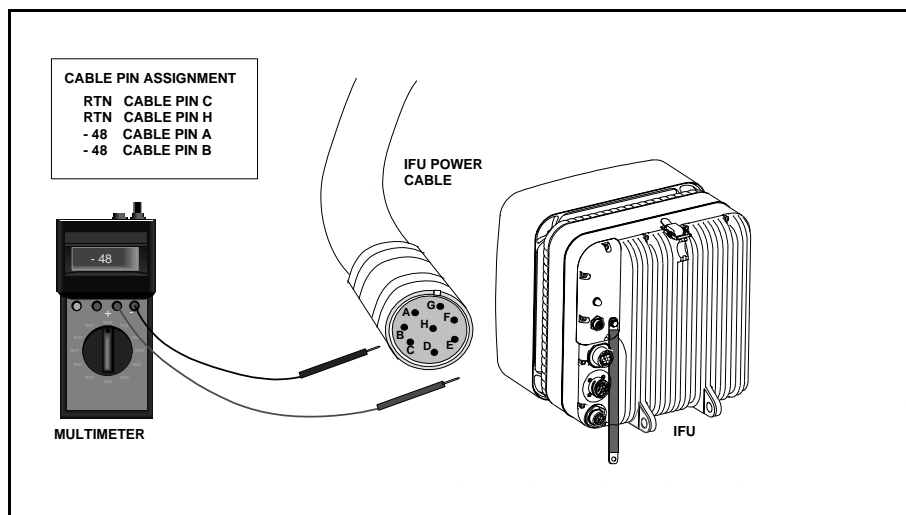

Figure 2-3. Power Test Setup

- 6 Connect a red test lead from the **positive** input of the multimeter to pin **A** on the IFU power cable.
- 7 Read the measurement on the multimeter. Passing criteria is – 46 Vdc to – 56 Vdc.
- 8 Connect a black test lead from the **negative** input of the multimeter to pin **H** on the IFU power cable.
- 9 Connect a red test lead from the **positive** input of the multimeter to pin **B** on the IFU power cable.
- 10 Read the measurement on the multimeter. Passing criteria is – 46 Vdc to – 56 Vdc.
- 11 Set the – 48 Vdc power source to OFF.



**DANGER – HIGH CURRENT HAZARD:** Do not turn on power before reading the Triton Network Systems' product documentation. This device has a – 48 Vdc (4 amps operating peak per feed) direct current input.

**DANGER – L'HASARD DU COURANT ÉLEVÉ :** Ne pas mettre la tension avant de lire la documentation du produit fournie par la société Triton Network Systems. Cet appareil a une alimentation directe de – 48 V CC (courant de pointe de 4 ampères par ligne d'alimentation).

---



**DANGER – HIGH CURRENT HAZARD:** Ensure that the – 48 Vdc power source is set to the OFF position before beginning the installation procedures for the Invisible Fiber™ Unit.

**DANGER – L'HASARD DU COURANT ÉLEVÉ :** S'assurer que le bloc d'alimentation – 48 V CC est en position HORS TENSION avant d'aborder les procédures pour l'installation de l'unité Invisible Fiber<sup>MD</sup>.

---

- 12 Connect – 48 Vdc power cable to the power connector on the IFU as illustrated in Figure 2-4.

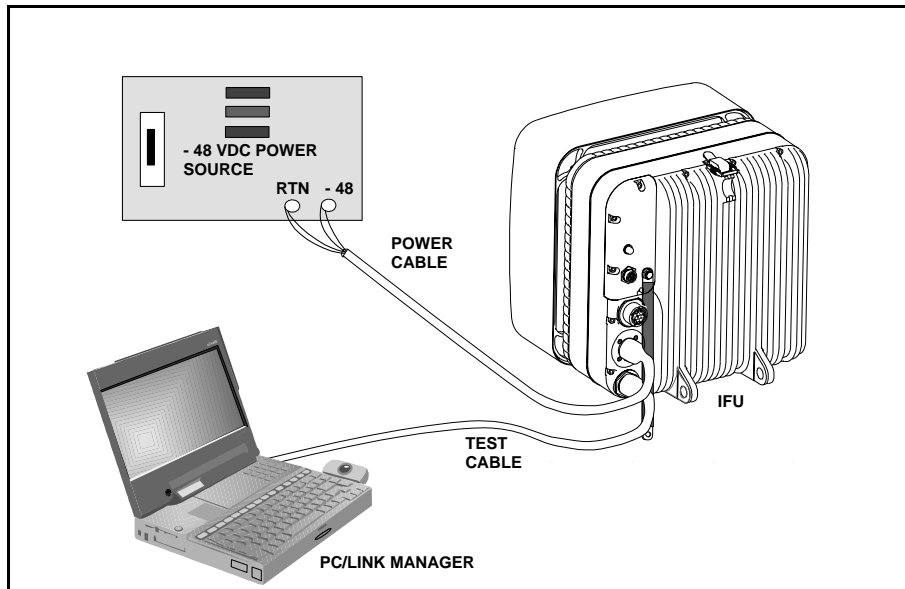

Figure 2-4. IFU Configuration Setup

13 Set the - 48 Vdc power source to ON.

**WARNING:** Beware! Radio transmitter is ON when the red light indicator on back side of Invisible Fiber™ unit is illuminated. Observe all radio frequency energy exposure and service interruption cautions.



**MISE EN GARDE :** Attention ! Le poste émetteur est EN MARCHE lorsque le témoin rouge sur le dos de l'unité Invisible Fiber<sup>MD</sup> est allumé. Respecter toutes les mises en garde concernant l'exposition aux radiofréquences et l'interruption de service.

**WARNING – RF EXPOSURE HAZARD:** Ensure the safety of all personnel. Do not stand in front of the Invisible Fiber™ unit (antenna) in order to avoid possible harmful radio frequency energy exposure. Serious bodily injury may result.



**MISE EN GARDE – RF EXPOSURE HAZARD :** Assurer la sécurité de tout le personnel. Ne pas rester debout devant l'unité Invisible Fiber<sup>MD</sup> (l'antenne) afin d'éviter toute exposition dangereuse aux radiofréquences. Les lésions corporelles sérieux s'ensuivre.

- 14 Connect a laptop computer to the IFU as shown in Figure 2-4.
- 15 Enter the site attributes from the site database into the IFU Link Manager program.

**NOTE:** Refer to IFU Link Manager help screens to enter the required site database attributes.

- 16 Power down the IFU and remove the cables.

**NOTE:** If the staging site and the installation site are the same place, continue with Chapter 3, *Installation Procedures*.

- 17 Confirm that the correct installation address is on the packing box and the packing box label matches the IFU data plate, located on the back of the IFU.
- 18 Use the original packing material to ship the IFU to the installation site. Should the packing material not be available, contact Triton Network Systems (see *Contacting Triton Network Systems, Inc.* on page xiii) for packing instructions.





# *Installation Procedures*

This chapter provides the procedures for installing IFU components and IFUs.

---

**NOTE:** Observe all federal and local laws, regulations, electrical codes, building codes, fire codes, and licensing agreements.

Il faut respecter l'ensemble des lois, règlements, codes du bâtiment et codes des incendies du gouvernement fédéral et des municipalités ainsi que tous les contrats de licence.

---

---

**NOTE:** Failure to follow the installation procedure described in the Triton Network Systems' product documentation may result in damage to the Invisible Fiber™ unit and render the unit unusable. Read through the entire installation procedure before beginning installation.

L'inobservation de la procédure d'installation décrite dans la documentation du produit fournie par la société Triton Network Systems peut endommager l'unité Invisible Fiber<sup>MD</sup> et la rendre inutilisable.

---

This chapter includes the following topics:

- Setup
- Installing IFU components
- Installing an IFU

The instructions in this chapter describes the procedure for installing two IFUs. Use the same process to install one IFU or many IFUs; the wiring conventions are the same.

## Setup

### Before Starting

Before starting the procedures in this chapter, verify that all parts have been received by checking the received items against the equipment and parts lists in the site engineering folder.

### Preparing for Installation

Table 3-1 identifies the special tools required for installation and Table 3-2 identifies the parts required.

**Table 3-1.** Site Installation Tools

Item No.	Description	Qty.
1	Digital multimeter	1
2	Fiber cleaning kit (solution & air)	1
3	Fiber scope	1
4	Fiber tester transmitter	1
5	Fiber tester receiver	1
6	Fiber test adapter	2
7	Site engineering folder	1
8	Right-angled snap ring pliers (for external snap ring)	1

**Table 3-2.** Site Installation Parts (for two IFUs)

Item No.	Description	Qty.
1	IFU	2
2	IFU mounting bracket with snap ring kit	2
3	IFU power cable	2
4	Fiber optic cable	2
5	Tie-wraps, UV-rated	A/R



# Installing IFU Components

This section describes how to:

- Mount the IFU bracket
- Install the power cables
- Install fiber optic cables

## Mounting the IFU Bracket

Using approved engineering methods, mount the IFU bracket in the location specified in the site engineering folder (see Figure 3-1 for typical wall mounting and Figure 3-2 for a typical pole mounting).

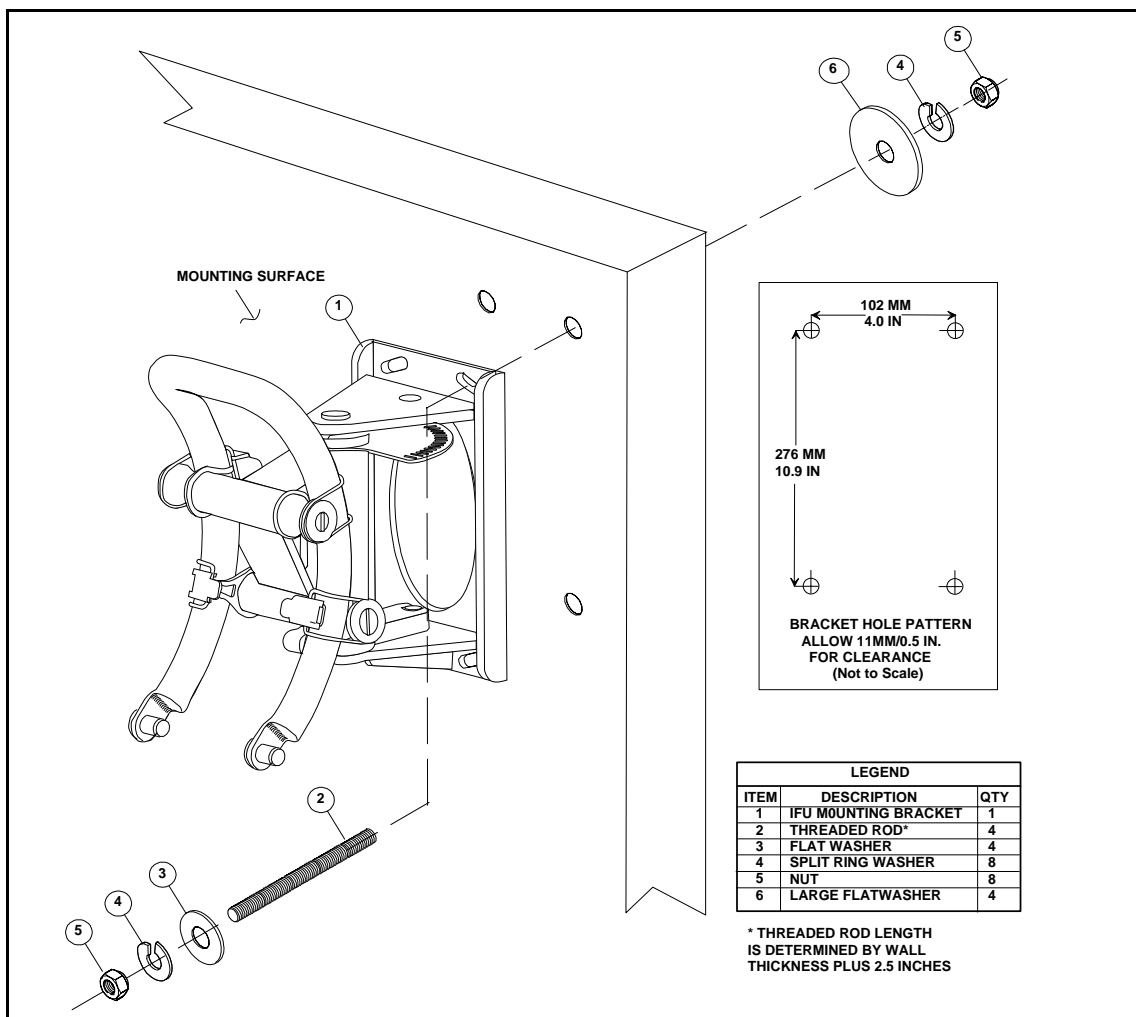

**Figure 3-1.** Example of IFU Bracket Attached to Wall

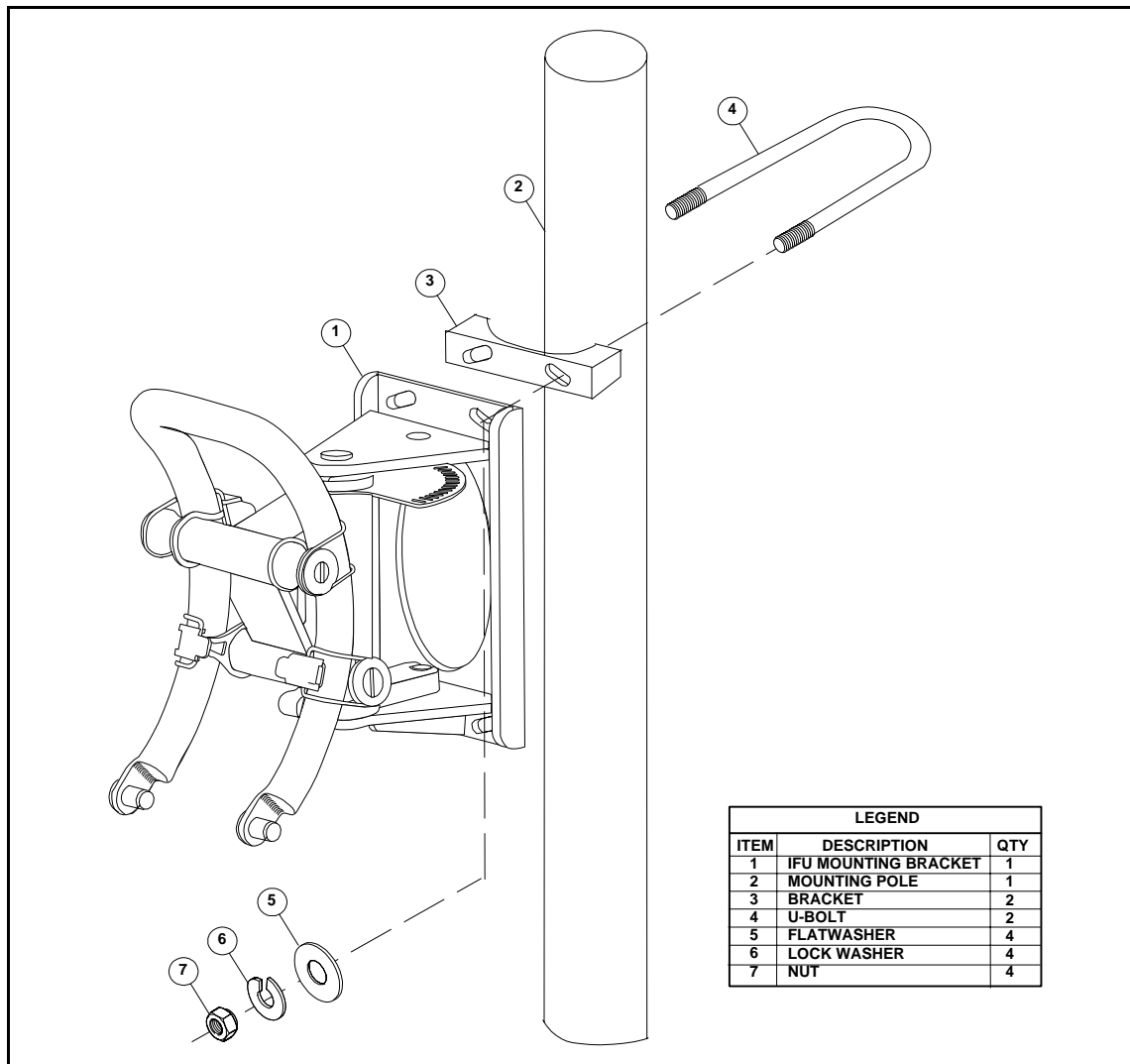

**Figure 3-2.** Example of IFU Bracket Attached to Pole

**NOTE:** Refer to the site engineering folder for location and mount the bracket to the building or pole, using bolts as indicated.

**NOTE:** Ensure the mounting bracket is mechanically stable, plumb, and level.

## Installing Power Cables

There are two cable routes as follows:

- The IFU Alpha power cable runs from the IFU mounting location to the surge suppression assembly.
- The IFU Beta power cable runs from the IFU mounting location to the surge suppression assembly.

► **To install the IFU power cables:**



---

**DANGER – HIGH VOLTAGE HAZARD:** Do not work on the system or connect or disconnect cables during periods of lightning activity, rainy weather, or both.

**DANGER – L'HASARD DU TENSION ÉLEVÉ :** Ne pas travailler sur le système ni brancher ni débrancher les câbles durant l'activité de la foudre, par de temps pluvieux, ou tous le deux.

---



---

**CAUTION:** Instructions for installing cables are intended for licensed contractors or building maintenance personnel.

**MISE EN GARDE :** Les instructions pour l'installation des câbles sont destinées exclusivement aux entrepreneurs agréés et aux préposés à l'entretien de l'immeuble.

---

- 1 Route the IFU power cables to a surge suppression assembly according to the site drawing.

**NOTE:** Allow an extra three-foot service loop at the IFU and twelve inches at each surge suppressor. Use large radius bends to avoid kinking the cables during the cable routing.

**NOTE:** Connect the cable shields to the suppressor mounting panel. Trim the shield back to the cable breakout and keep the shield as short as possible.

- 2 Trim each cable to the appropriate length.
- 3 Strip each cable wire to 3/8 inch and tin.
- 4 Attach the IFU power cables to the surge suppressors as shown on Figure 3-3, Figure 3-4, and Table 3-3.

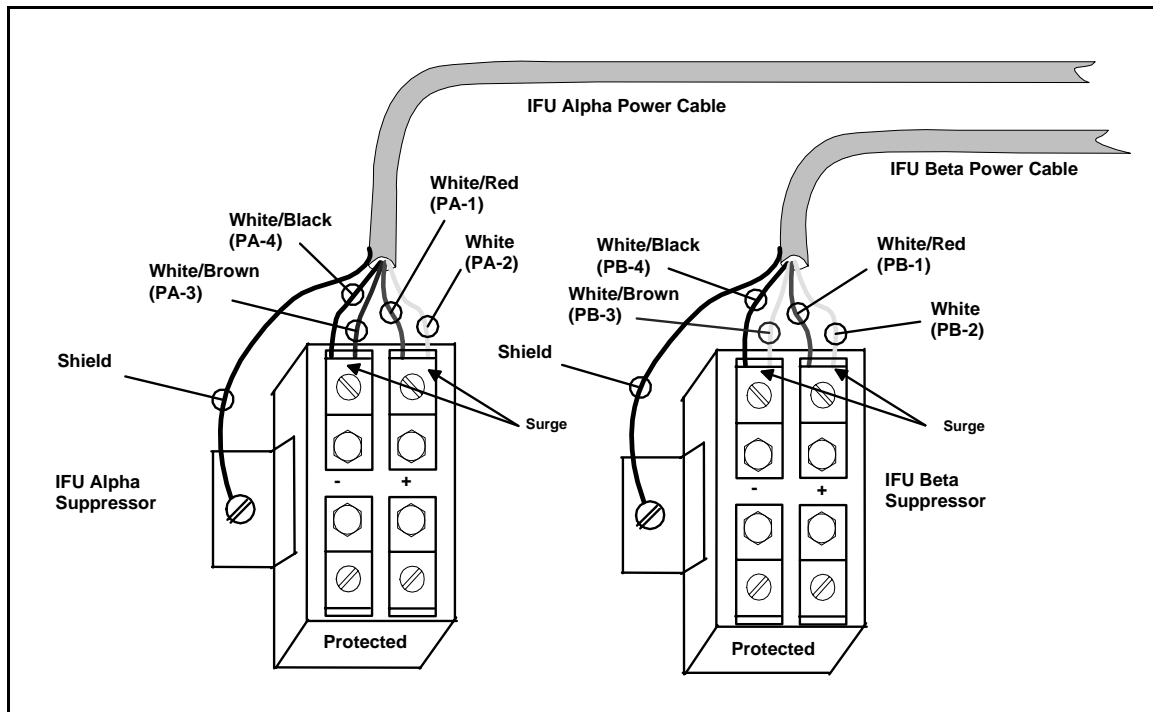

**Figure 3-3.** Typical Power Cable Wiring

**Table 3-3.** Typical Power Cable Wiring

IFU Alpha Surge Input	Wire Color/ Number	IFU Beta Surge Input	Wire Color/ Number
RTN (+)	White (PA-2), White/Red (PA-1)	RTN (+)	White (PB-2), White/Red (PB-1)
- 48 (-)	White/Black (PA-4), White/Brown (PA-3)	- 48 (-)	White/Black (PB-4), White/Brown (PB-3)

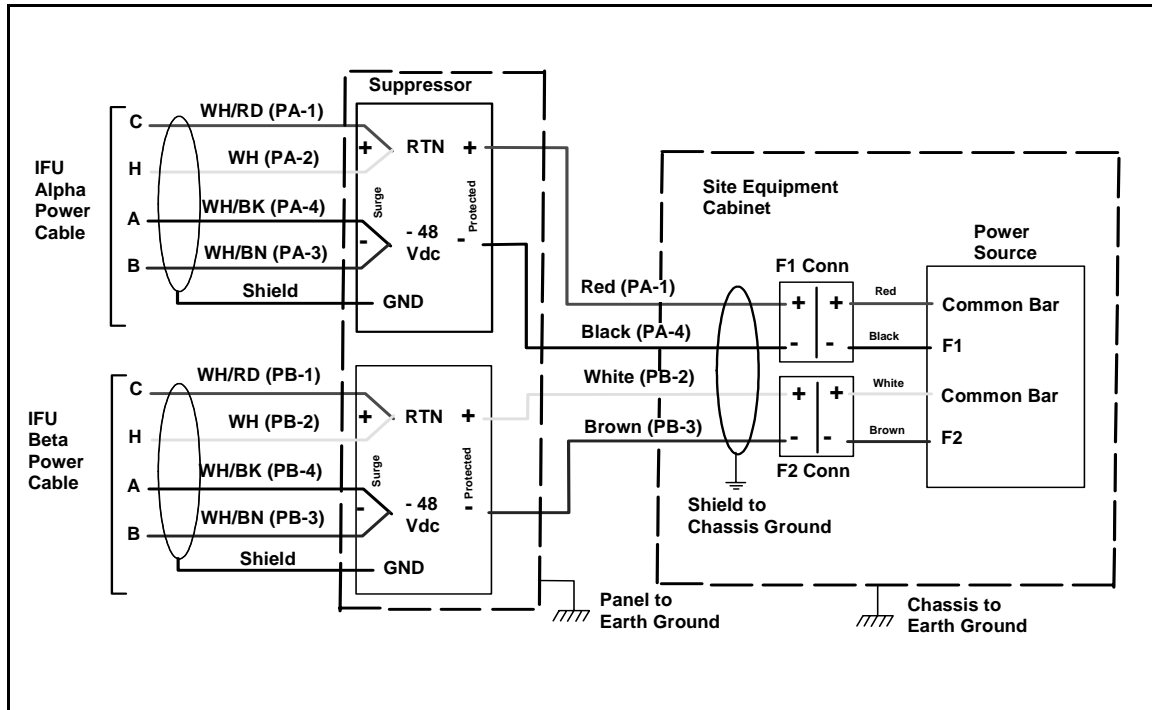

Figure 3-4. Typical IFU Power Termination Wiring Schematic

## IFU Power Cable Test

To ensure proper wiring, perform the input power test on both IFU power cables prior to connecting to the IFU. This test ensures that the input power to the IFU is between  $-46$  Vdc and  $-56$  Vdc.

### ► To test the power cable:

**DANGER – HIGH VOLTAGE HAZARD:** Do not work on the system or connect or disconnect cables during periods of lightning activity, rainy weather, or both.



**DANGER – L'HASARD DU TENSION ÉLEVÉ :** Ne pas travailler sur le système ni brancher ni débrancher les câbles durant l'activité de la foudre, par de temps pluvieux, ou tous le deux.

- 1 Set the – 48 Vdc power source to ON.
- 2 Set multimeter to DC voltage.
- 3 At the mounting location, connect a black test lead from the **negative** input of the multimeter to pin **C** on the power cable (see Figure 3-5).

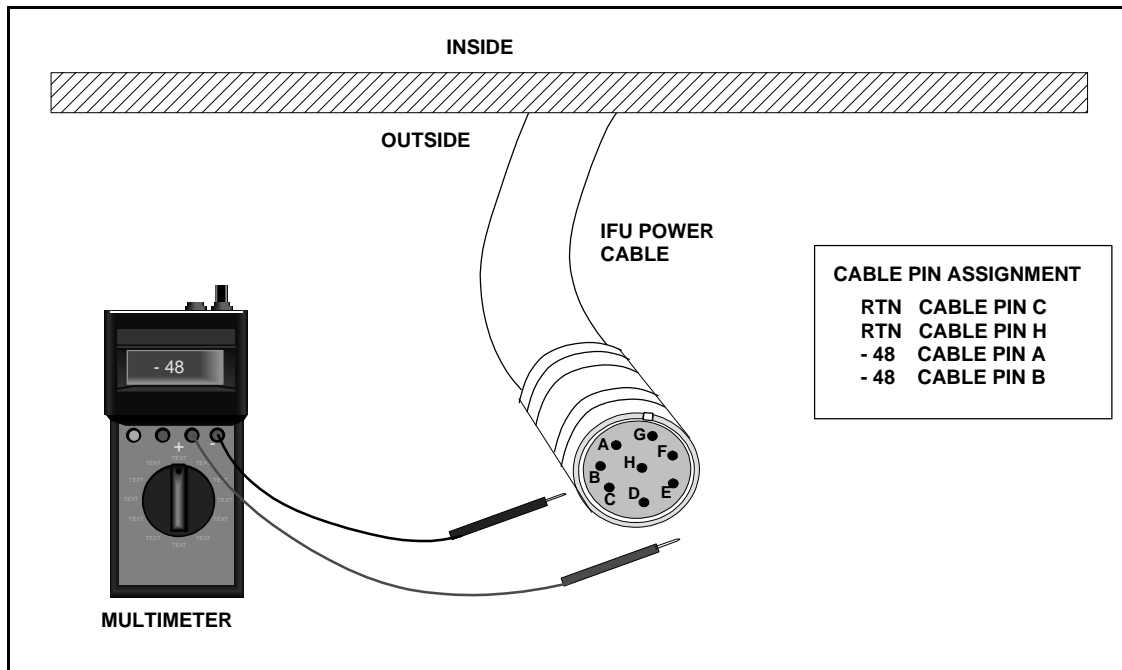

Figure 3-5. Power Test Setup

- 4 Connect a red test lead from the **positive** input of the multimeter to pin **A** on the power cable. Record the results in *Table A-1 on page A-1*.
- 5 Read the measurement on the multimeter. Passing criteria is – 46 Vdc to – 56 Vdc. Record the results in *Table A-1 on page A-1*.
- 6 Connect a black test lead from the **negative** input of the multimeter to pin **H** on the power cable.
- 7 Connect a red test lead from the **positive** input of the multimeter to pin **B** on the power cable.
- 8 Read the measurement on the multimeter. Passing criteria is – 46 Vdc to – 56 Vdc. Record the results in *Table A-1 on page A-1*.

Repeat the above test for each IFU power cable.

## Installing the Fiber Optic Cable

There are two fiber optic cable routes as follows:

- The IFU Alpha fiber optic cable runs from the IFU mounting location to the site equipment cabinet.
- The IFU Beta fiber optic cable runs from the IFU mounting location to the site equipment cabinet.

### ► To install the fiber optic cable:



**WARNING:** Never touch exposed fiber with any part of your body. Fiber fragments can enter the skin and are difficult to detect and remove.

**AVERTISSEMENT :** Ne jamais laisser une fibre nue entrer en contact avec une partie quelconque du corps. Des fragments de fibre peuvent entrer dans la peau, et sont difficiles à déceler et à enlever.

---



**DANGER:** Invisible laser radiation. Avoid direct eye exposure to the end of a fiber, fiber cord, or fiber pigtail. The infrared light used in fiber optics systems is invisible, but can cause serious injury to the eye.

**AVERTISSEMENT :** Rayonnement laser invisible. Éviter l'exposition directe des yeux à l'extrémité d'une fibre, d'un cordon à fibres ou d'une fibre amorce. La lumière infrarouge utilisée dans les systèmes à fibres optiques est invisible, mais peut provoquer des lésions graves aux yeux.

---



**CAUTION:** Ensure the outside optical fiber connectors are environmentally protected. Failure to do so may cause contamination of the fiber surfaces.

**MISE EN GARDE :** S'assurer que les raccords extérieurs fibre optique sont protégés contre l'environnement. L'absence d'une telle protection peut entraîner la contamination des surfaces des fibres.

---

---

**CAUTION:** To reduce the risk of fiber optic cable damage, use the following bend radius guidelines for indoor/outdoor fiber optic cable:

- Long-term (installed): bend radius is equal to 10 times the diameter of the cable.
- Short-term (during installation): bend radius is equal to 20 times the diameter of the cable.



**MISE EN GARDE :** Pour réduire le risque de dommage aux câbles à fibres optiques, suivre les consignes suivantes en matière de rayon de courbure des câbles à fibres optiques extérieurs ou intérieurs :

- Courbure à long terme (installée). Le rayon de courbure ne doit pas dépasser 10 fois le diamètre du câble.
- Courbure à court terme (pendant l'installation). Le rayon de courbure ne doit pas dépasser 20 fois le diamètre du câble.

- 
- 1 Route the IFU fiber optic cables from each of the IFU mounting locations to the site equipment cabinet. Refer to the site drawing in the site engineering folder for the specific route.

**NOTE:** Allow an extra three-foot service loop at both ends. Use large radius bends to avoid crimping and kinking the cables during the cable routing.

- 2 Connect the IFU fiber optic cables to the rear side of the patch panel as shown in Figure 3-6 and Table 3-4.



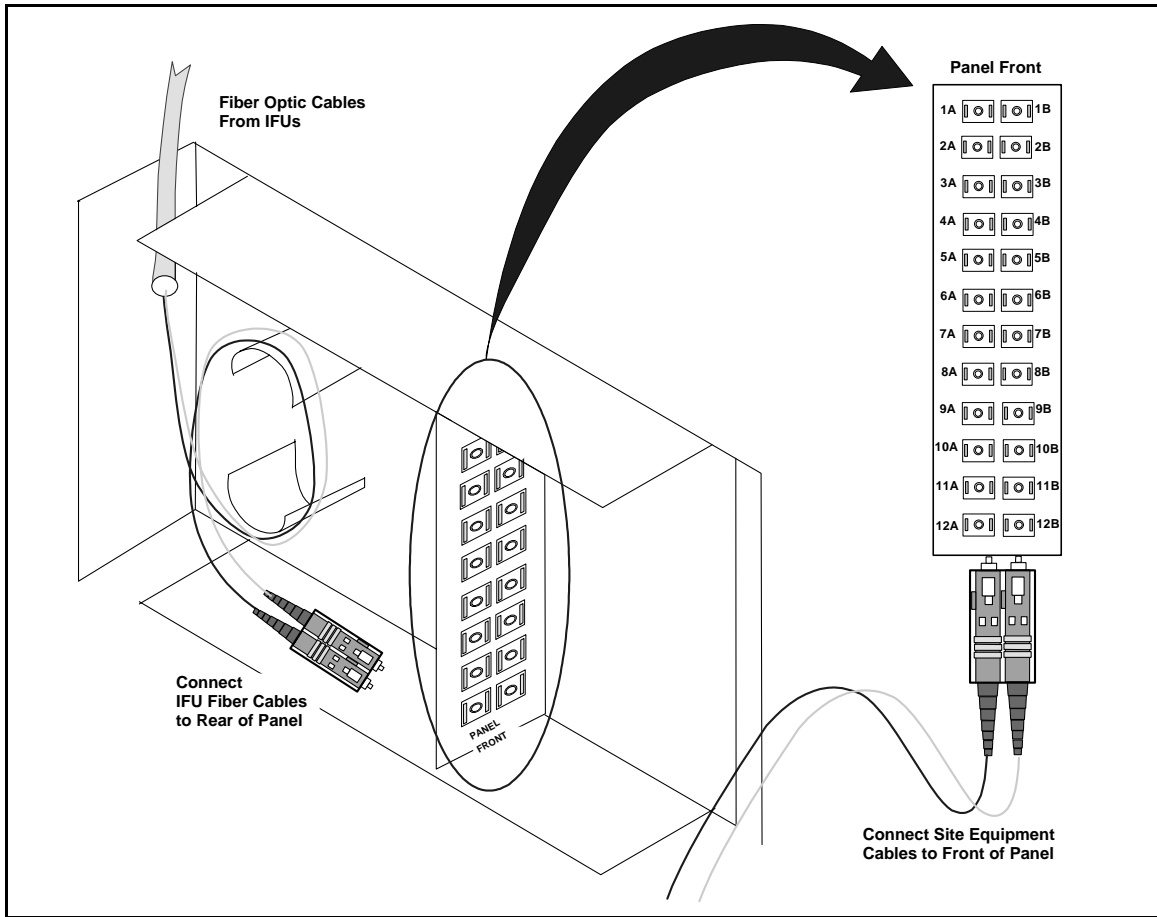

Figure 3-6. Demarcation Patch Panel

**Table 3-4.** Typical SONET OC-3 Demarcation Panel Input Connections

Fiber Function	Fiber Color/Number	Rear of Demarcation Panel	Fiber Type
IFU Alpha Payload TX	Gray (FA-1)	1A	Single-Mode
IFU Alpha Payload RX	White (FA-2)	1B	Single-Mode
IFU Alpha OAM&P TX	Green (FA-3)	2A	Multimode
IFU Alpha OAM&P RX	Brown (FA-6)	2B	Multimode
IFU Alpha Interconnect TX	Blue (FA-7)	3A	Multimode
IFU Alpha Interconnect RX	Orange (FA-8)	3B	Multimode
IFU Beta Payload TX	Gray (FB-1)	4A	Single-Mode
IFU Beta Payload RX	White (FB-2)	4B	Single-Mode
IFU Beta OAM&P TX	Green (FB-3)	5A	Multimode
IFU Beta OAM&P RX	Brown (FB-6)	5B	Multimode
IFU Beta Interconnect TX	Blue (FB-7)	6A	Multimode
IFU Beta Interconnect RX	Orange (FB-8)	6B	Multimode

- 3 Connect the jumpers to the front of the demarcation patch panel as shown in Figure 3-6, Figure 3-7, Figure 3-8 and Table 3-5.

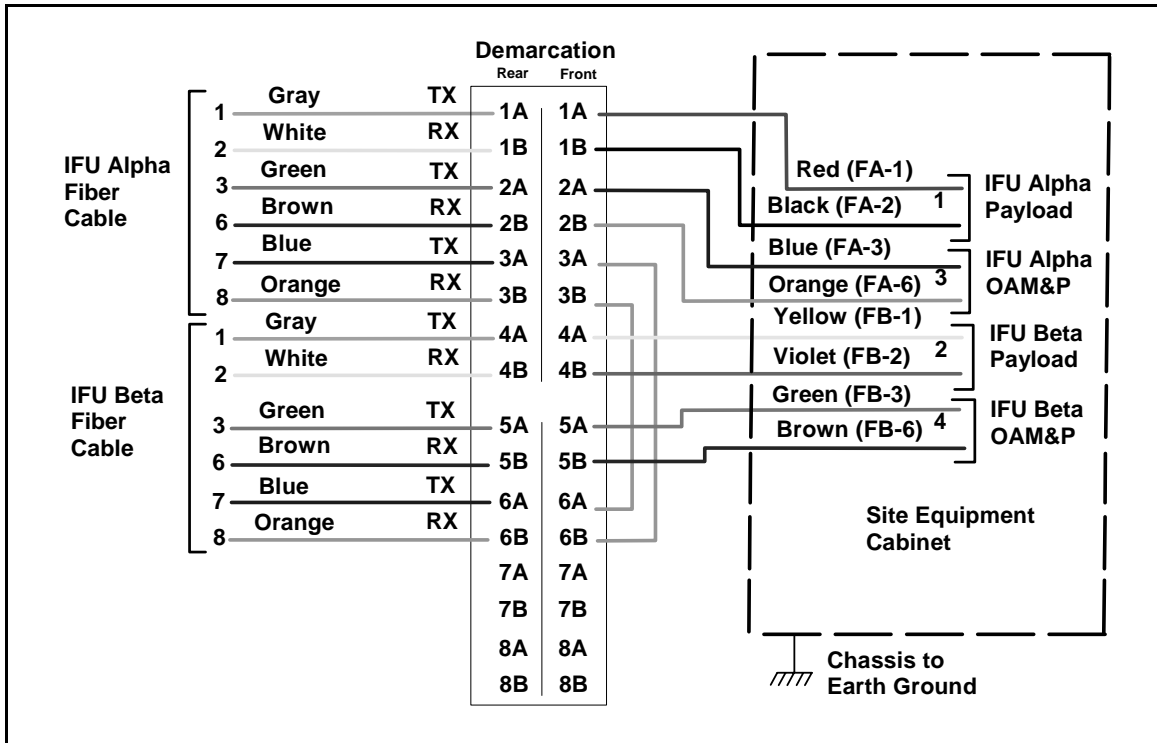
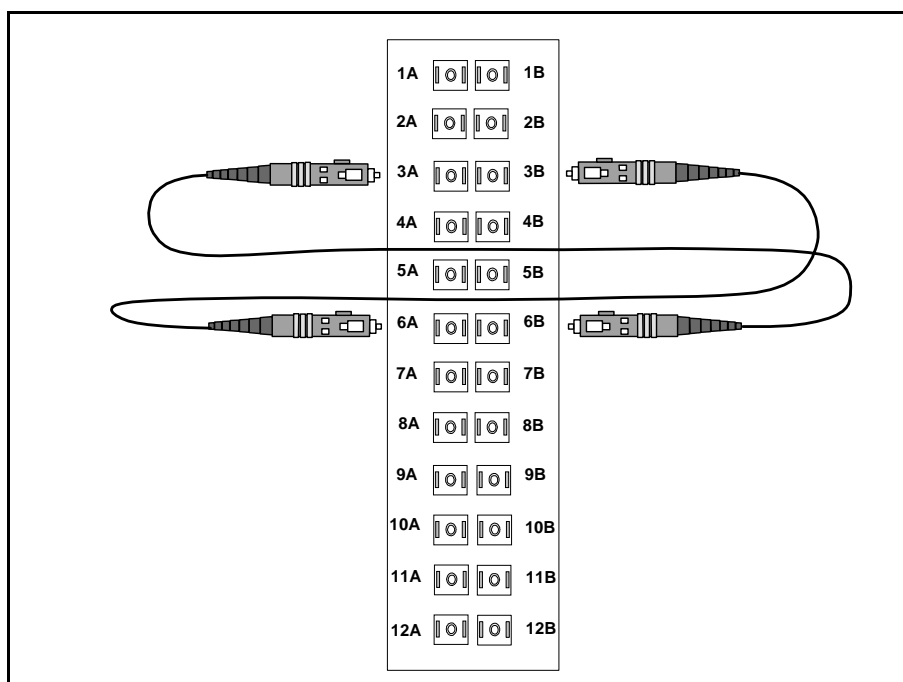

Figure 3-7. Typical SONET OC-3 Site Schematic



**Figure 3-8.** Typical SONET OC-3 Demarcation Jumper Locations

**Table 3-5.** Typical SONET OC-3 Demarcation Panel Jumper Connections

Fiber Function	From	To	Fiber Function
IFU Alpha Interconnect TX	3A	6B	IFU Beta Interconnect RX
IFU Alpha Interconnect RX	3B	6A	IFU Beta Interconnect TX

## Fiber Optic Continuity Test

This test is to ensure that the signal loss in the fiber optic assemblies meet the specifications and that cables have not been damaged during installation. The fiber optic continuity test consists of:

- Cleaning the fiber optic cable
- Testing the fiber optic cable

---

► **To clean the fiber optic cable:**



**WARNING:** Never touch exposed fiber with any part of your body. Fiber fragments can enter the skin and are difficult to detect and remove.

**AVERTISSEMENT :** Ne jamais laisser une fibre nue entrer en contact avec une partie quelconque du corps. Des fragments de fibre peuvent entrer dans la peau, et sont difficiles à déceler et à enlever.

---



**DANGER:** Invisible laser radiation. Avoid direct eye exposure to the end of a fiber, fiber cord, or fiber pigtail. The infrared light used in fiber optics systems is invisible, but can cause serious injury to the eye.

**AVERTISSEMENT :** Rayonnement laser invisible. Éviter l'exposition directe des yeux à l'extrémité d'une fibre, d'un cordon à fibres ou d'une fibre amorce. La lumière infrarouge utilisée dans les systèmes à fibres optiques est invisible, mais peut provoquer des lésions graves aux yeux.

---



**CAUTION:** Ensure the outside optical fiber connectors are environmentally protected. Failure to do so may cause contamination of the fiber surfaces.

**MISE EN GARDE :** S'assurer que les raccords extérieurs fibre optique sont protégés contre l'environnement. L'absence d'une telle protection peut entraîner la contamination des surfaces des fibres.

---

---

**CAUTION:** To reduce the risk of fiber optic cable damage, use the following bend radius guidelines for indoor/outdoor fiber optic cable:

- Long-term (installed): bend radius is equal to 10 times the diameter of the cable.
- Short-term (during installation): bend radius is equal to 20 times the diameter of the cable.



**MISE EN GARDE :** Pour réduire le risque de dommage aux câbles à fibres optiques, suivre les consignes suivantes en matière de rayon de courbure des câbles à fibres optiques extérieurs ou intérieurs :

- Courbure à long terme (installée). Le rayon de courbure ne doit pas dépasser 10 fois le diamètre du câble.
- Courbure à court terme (pendant l'installation). Le rayon de courbure ne doit pas dépasser 20 fois le diamètre du câble.

- 
- 1 Remove the dust cap on the connector. Using the automatic cleaner, wipe the connector once in each direction across cleaning pad.
  - 2 With canned air, blow a slow 3 to 4 second burst of air across fiber/ferrule end face to dry connector then replace the dust cap.
  - 3 Repeat Step 1 and Step 2 on the other end of fiber optic cable.

**NOTE:** Never leave connectors unprotected after cleaning.

- 4 Attach the fiber optic cable to the scope and inspect for dirt, grease, defects, dust, oil, etc.
- 5 Repeat Step 1 and Step 2, if necessary.

► **To test the fiber optic cable:**

- 1 Connect fiber optic test adapters to the IFU Alpha and IFU Beta fiber cables.
- 2 Carefully place the laser receiver IFU Beta test adapter (see Figure 3-9 and Table 3-6).

**NOTE:** Never connect the transmitter first.

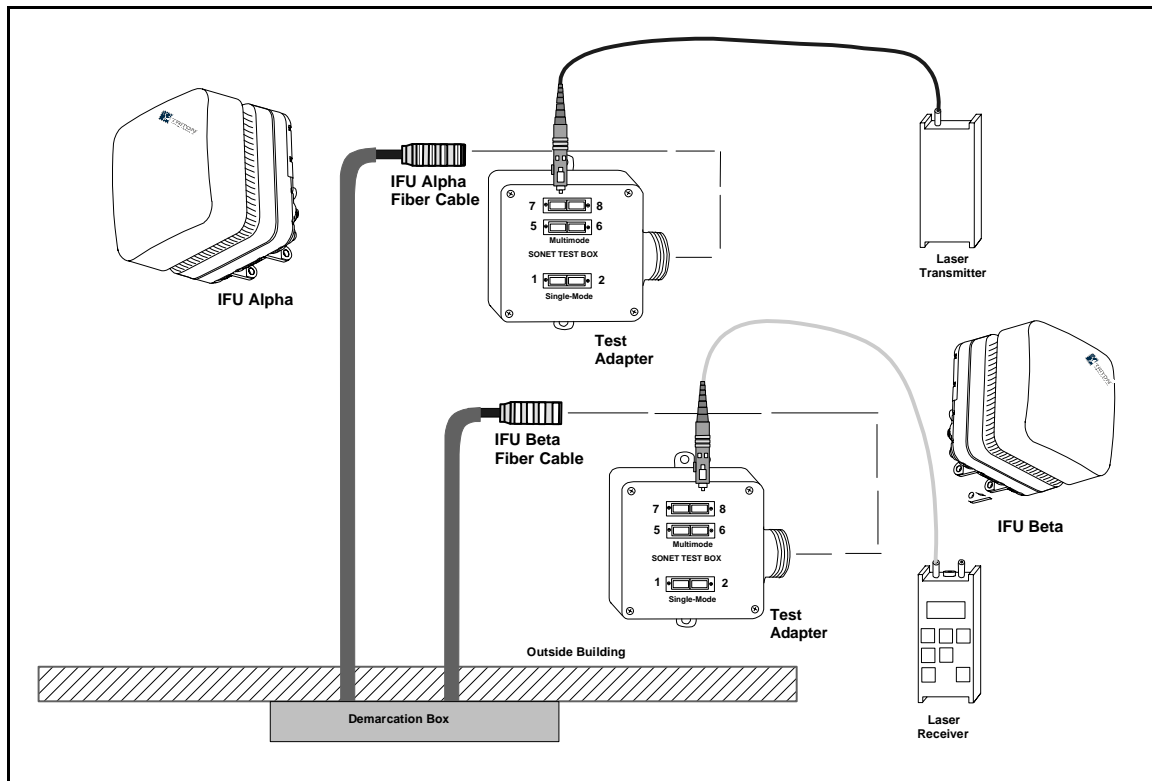

**Figure 3-9.** SONET OC-3 Fiber Optic Continuity Test Setup

- 3 Connect the transmitter to the IFU Alpha test adapter as called out in Table 3-6.
- 4 Set the transmitter to 0 dBm continuous wave and 1310 nm.
- 5 Turn on both units and take readings at the receiver. Record the results in Table A-2 on page A-2.

**NOTE:** The received signal should be stronger than  $-7.4$  dBm (less than  $7.4$  dB).

Repeat steps 1 through 5 on each fiber optic cable.

**Table 3-6.** SONET OC-3 Fiber Test Connections

IFU Alpha Fiber Name	IFU Alpha Test Adapter Connector	IFU Beta Test Adapter Connector	IFU Beta Fiber Name
IFU Alpha Interconnect TX	7	8	IFU Beta Interconnect RX
IFU Alpha Interconnect RX	8	7	IFU Beta Interconnect TX

## Installing an IFU

IFUs are installed in the locations as specified by each site drawing. A near-end IFU is the first installed IFU in a pair, and the far-end IFU is the second in the pair. Figure 3-10 provides a close-up view of an installed IFU. Installing an IFU is a two-part process:

- 1 Mounting the IFU to the mounting bracket.
- 2 Attaching cables to the IFU.

## Mounting the IFU

Verify the correct IFU for location by checking the product number on the IFU against the site drawing in the site engineering folder.

---

**CAUTION:** Lifting hazard: Two people are required to lift the Invisible Fiber™ unit. Grasp the Invisible Fiber™ unit underneath the lower edge and lift with both hands. To prevent injury, keep your back straight and lift with your legs, not your back. To prevent damage to the Invisible Fiber™ unit and components, never attempt to lift the radio by the attached cables.



**MISE EN GARDE :** Danger de levage. Il faut deux personnes pour soulever l'unité Invisible Fiber<sup>MD</sup>. Saisir l'unité Invisible Fiber<sup>MD</sup> au-dessous du rebord inférieur, puis soulever l'unité avec les deux mains. Pour éviter les lésions corporelles, garder le dos en position verticale et soulever l'unité en utilisant les jambes et non pas les reins. Pour éviter l'endommagement de l'unité Invisible Fiber<sup>MD</sup> et de ses composants, ne jamais essayer de soulever la radio en tirant sur les câbles qui y sont attachés.

---



**CAUTION:** Keep tools and parts away from walkways. When carrying large, heavy equipment (such as the Invisible Fiber™ unit), obstacles (such as hand tools, cables or components) may not be easily visible and can cause accidents.



**MISE EN GARDE :** Garder les outils et les pièces loin des allées. Lorsqu'on transporte des équipements lourds et à grandes dimensions (tels que l'unité Invisible Fiber<sup>MD</sup>), les obstacles (tels que les outils à main, les câbles ou les composants) sont parfois difficiles à voir et peuvent causer des accidents.

- 3 Refer to Figure 3-10 and position the IFU (2) on the mounting studs (7) and engage the top clamp.
- 4 Install a snap ring (3) on each mounting stud (7).

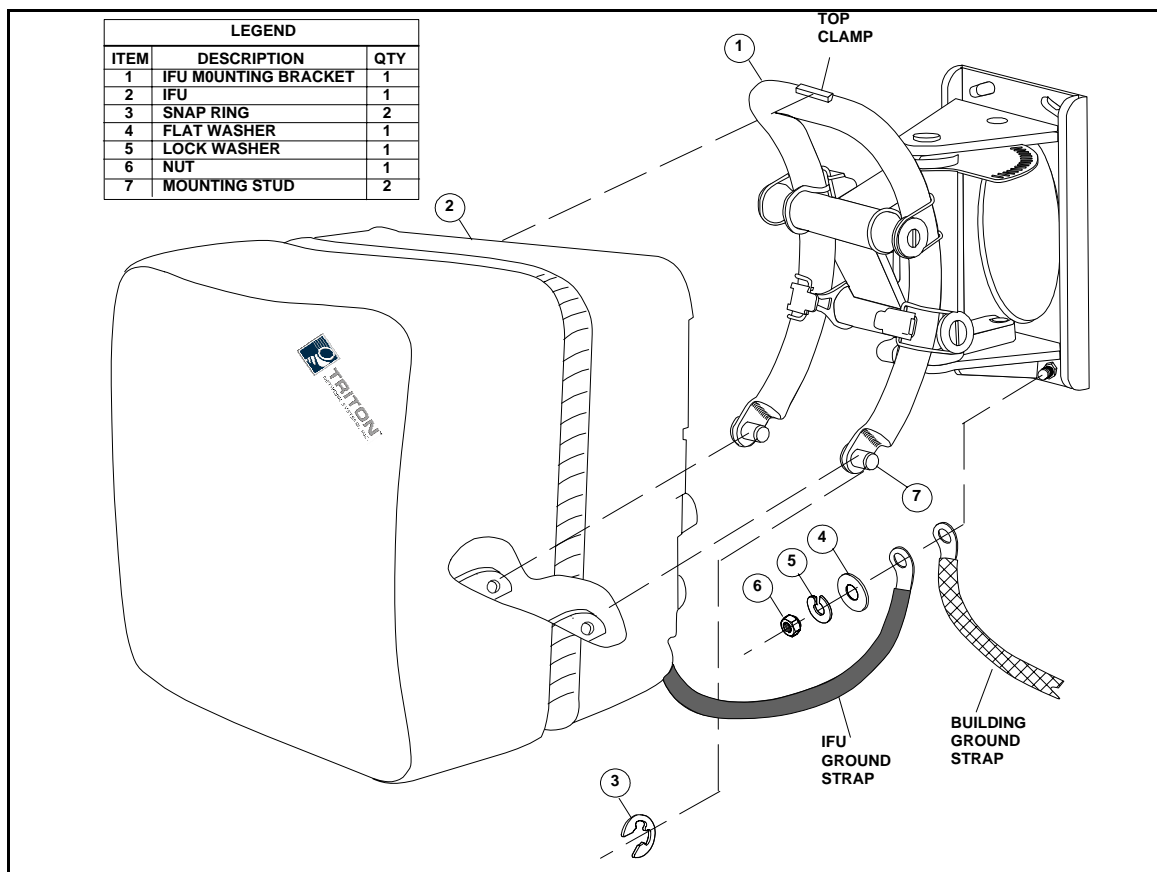

**Figure 3-10.** Mounting the IFU

- 5** Position the building ground strap, IFU ground strap, flat washer (4), and lock washer (5) on the bottom bolt of the mounting bracket (1) and install nut (6).

## Attaching IFU Cables

- To test the fiber optic cable:



---

**DANGER – HIGH CURRENT HAZARD:** Ensure that the – 48 Vdc power source is set to the OFF position before beginning the installation procedures for the Invisible Fiber™ unit.

**DANGER – L'HASARD DU COURANT ÉLEVÉ :**  
S'assurer que le bloc d'alimentation – 48 V CC est en position HORS TENSION avant d'aborder les procédures pour l'installation de l'unité Invisible Fiber<sup>MD</sup>.

---

- 1 Connect the power and fiber optic cable to the IFU locations as shown in Figure 3-11.

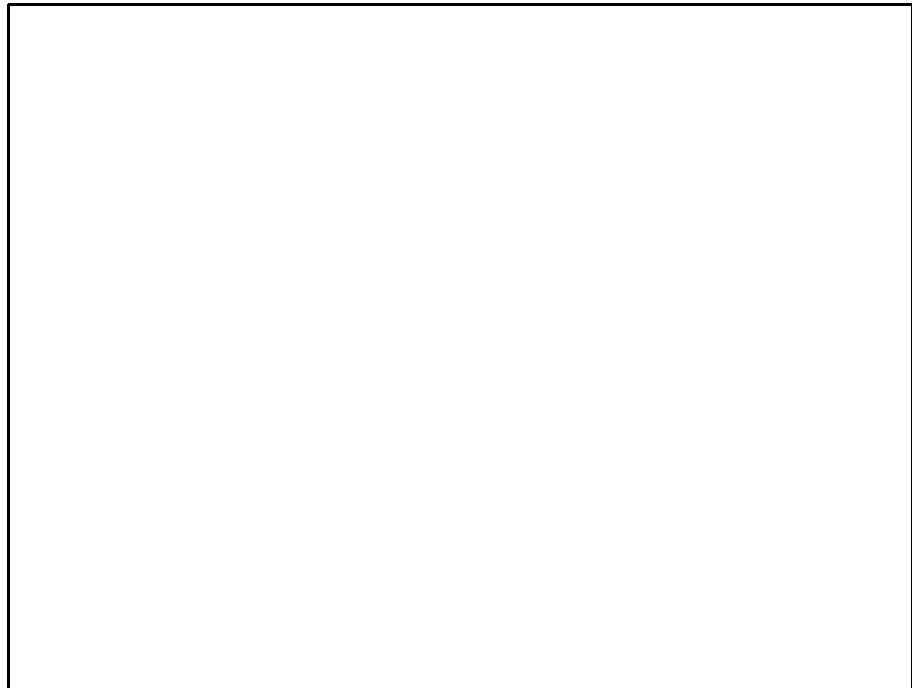

**Figure 3-11.** IFU Cable Connections

- 2 Secure the power and fiber optic cables to the building with tie-wraps as needed.





# Commissioning Procedures

This chapter provides the procedures for commissioning IFUs

---

**NOTE:** Observe all federal and local laws, regulations, electrical codes, building codes, fire codes, and licensing agreements.

Il faut respecter l'ensemble des lois, règlements, codes d'électrique, codes du bâtiment et codes des incendies du gouvernement fédéral et des municipalités ainsi que tous les contrats de licence.

---

**NOTE:** Failure to follow the installation procedure described in the Triton Network Systems' product documentation may result in damage to the Invisible Fiber™ unit and render the unit unusable.

L'inobservation de la procédure d'installation décrite dans la documentation du produit fournie par la société Triton Network Systems peut endommager l'unité Invisible Fiber<sup>MD</sup> et la rendre inutilisable.

---

The following topics are included in this chapter:

- Aligning the Near-End IFU
- Commissioning the Far-End IFU
- Commissioning the Near-End IFU
- Testing the Link

## Setup

### Before Starting

Before starting the procedures in this chapter, ensure that the IFUs have been mounted at the near-end site and far-end site, and that the cables have been tested.

### Preparing for Installation

Table 4-1 identifies the basic commissioning tools required for commissioning the near-end and far-end sites.

**Table 4-1.** Site Commissioning Tools

Item No.	Description	Qty.
1	IFU Link Manager test cable	2
2	IFU Link Manager software	2
3	Personnel computer with IFU Link Manager installed	2
4	SONET test set	2
5	Digital multimeter (measures DC Voltage up to 100V, accuracy 0.3% or better)	2
6	BNC/banana interface cable	1
7	Site engineering folder	1

## Aligning the IFU

► To align the IFU:



**DANGER – HIGH VOLTAGE HAZARD:** Do not work on the system or connect or disconnect cables during periods of lightning activity, rainy weather, or both.

**DANGER – L'HASARD DU TENSION ÉLEVÉ :** Ne pas travailler sur le système ni brancher ni débrancher les câbles durant l'activité de la foudre, par de temps pluvieux, ou tous le deux.

- 1 Loosen the four vertical alignment screws on the IFU mounting bracket.
- 2 Coarse align the near-end IFU to the far-end IFU pair and the far-end IFU to the near-end IFU using an optical alignment tool (see Figure 4-1).

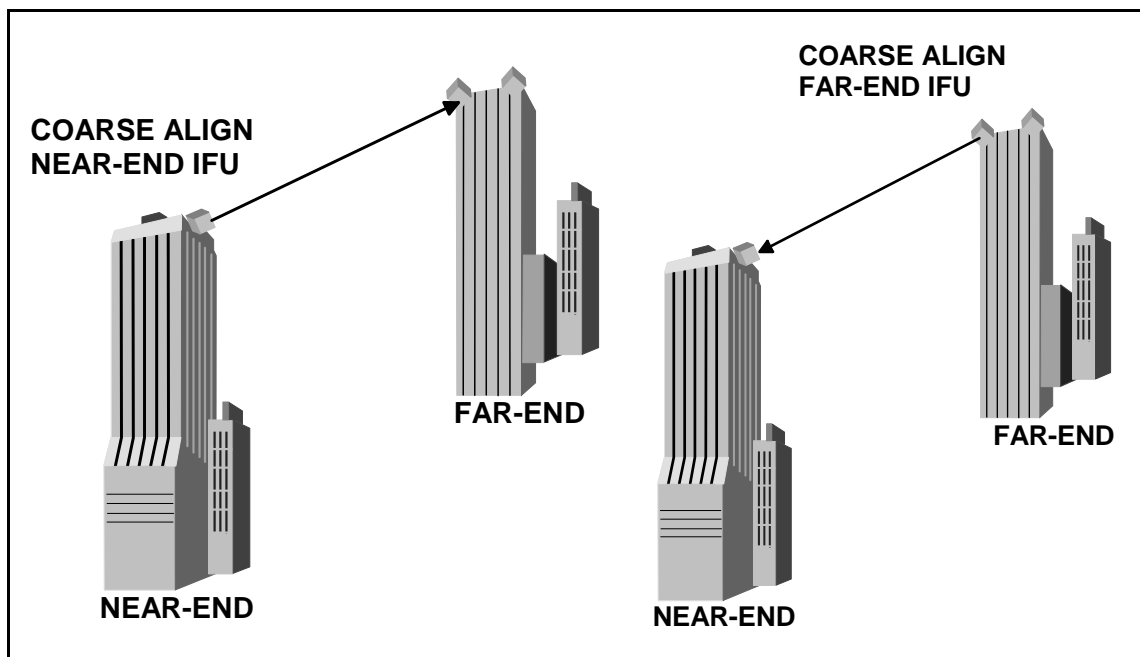

Figure 4-1. Coarse Alignment

- 3 Loosen the horizontal alignment nut on the holding bracket. Coarse align the near-end IFU to the designated far-end IFU using an optical alignment tool.
- 4 Tighten the four vertical screws and single horizontal nut on the IFU mounting bracket.

- 5 Set the – 48 Vdc power source to ON.
- 6 Remove the protective cap from the IFU test connector.



**DANGER – HIGH CURRENT HAZARD:** Do not turn on power before reading the Triton Network Systems' product documentation. This device has a – 48 Vdc (4 amps operating peak per feed) direct current input.

**DANGER – L'HASARD DU COURANT ÉLEVÉ :** Ne pas mettre la tension avant de lire la documentation du produit fournie par la société Triton Network Systems. Cet appareil a une alimentation directe de – 48 V CC (courant de pointe de 4 ampères par ligne d'alimentation).

- 7 Connect the IFU test cable to the test port of the near-end IFU.

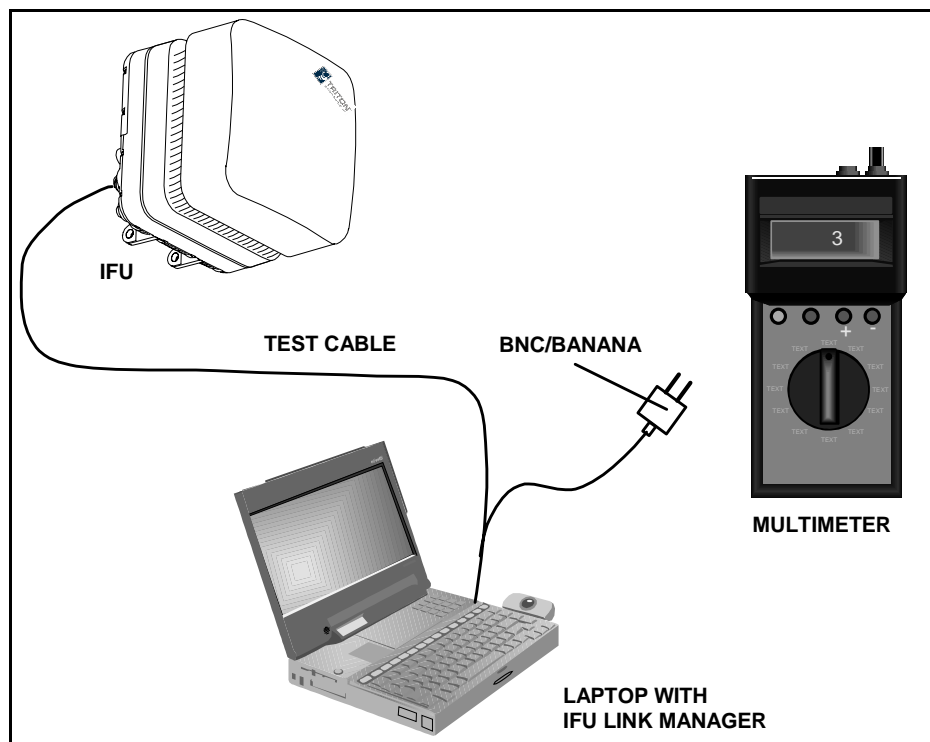

**Figure 4-2.** Alignment Test Setup

- 8 Connect the BNC plug of the test cable to the BNC/banana interface cable.
- 9 Connect the banana plug of the BNC/banana interface cable to the multimeter (red plug to the volt terminal, black plug to the Common terminal).



- 10 Turn on the multimeter and set it up to measure DC voltage.
- 11 Connect the RJ-45 plug of the test cable to the laptop.
- 12 Power up the laptop and access the IFU Link Manager application. Initialize the IFU if it has not been initialized (refer to IFU Link Manager online help).
- 13 Log on to the near-end IFU.
- 14 Use the IFU Link Manager application to set the near-end IFU radio transmitter to ON (refer to IFU Link Manager online help).
- 15 Ensure that the power control is OFF.

Repeat this procedure for the far-end IFU.

---

**WARNING:** Beware! Radio transmitter is ON when the red light indicator on back side of Invisible Fiber™ unit is illuminated. Observe all radio frequency energy exposure and service interruption cautions.



**MISE EN GARDE :** Attention ! Le poste émetteur est EN MARCHE lorsque le témoin rouge sur le dos de l'unité Invisible Fiber<sup>MD</sup> est allumé. Respecter toutes les mises en garde concernant l'exposition aux radiofréquences et l'interruption de service.

---

**WARNING – RF EXPOSURE HAZARD:** Ensure the safety of all personnel. Do not stand in front of the Invisible Fiber™ unit (antenna) in order to avoid possible harmful radio frequency energy exposure. Serious bodily injury may result.



**MISE EN GARDE – RF EXPOSURE HAZARD :** Assurer la sécurité de tout le personnel. Ne pas rester debout devant l'unité Invisible Fiber<sup>MD</sup> (l'antenne) afin d'éviter toute exposition dangereuse aux radiofréquences. Les lésions corporelles sérieux s'ensuivent.

---

## Commissioning the IFU

► **To commission the far-end IFU:**

- 1 Ensure the near-end IFU transmitter is set to ON.



**WARNING:** Beware! Radio transmitter is ON when the red light indicator on back side of Invisible Fiber™ unit is illuminated. Observe all radio frequency energy exposure and service interruption cautions.

**MISE EN GARDE :** Attention ! Le poste émetteur est EN MARCHÉ lorsque le témoin rouge sur le dos de l'unité Invisible Fiber<sup>MD</sup> est allumé. Respecter toutes les mises en garde concernant l'exposition aux radiofréquences et l'interruption de service.

---



**WARNING – RF EXPOSURE HAZARD:** Ensure the safety of all personnel. Do not stand in front of the Invisible Fiber™ unit (antenna) in order to avoid possible harmful radio frequency energy exposure. Serious bodily injury may result.

**MISE EN GARDE – RF EXPOSURE HAZARD :** Assurer la sécurité de tout le personnel. Ne pas rester debout devant l'unité Invisible Fiber<sup>MD</sup> (l'antenne) afin d'éviter toute exposition dangereuse aux radiofréquences. Les lésions corporelles sérieux s'ensuivre.

---

- 2 Loosen the four vertical screws on the holding bracket.
- 3 While viewing the multimeter, sweep the IFU vertically by pointing the IFU all the way up and then down. The measured voltage of the multimeter displays a succession of peak signals as the IFU moves. Specifically, the signal displays a “small” peak, a relatively higher peak, and then redisplay the “small” peak. Note the approximate position of the IFU when the higher peak occurs and the corresponding voltage value. The peak voltage should be approximately 3 Vdc.
- 4 Move the IFU to the higher peak position as indicated by the multimeter display.
- 5 Tighten the four vertical screws on the IFU mounting bracket.
- 6 Loosen the horizontal alignment nut on the IFU mounting bracket.

- 7 Sweep the IFU from the far left to the far right. The measured voltage of the multimeter displays a succession of peak signals as the IFU moves. Note the approximate position of the IFU when the higher peak occurs and the corresponding voltage value.
- 8 Move the IFU to the higher peak position as indicated by the multimeter display.
- 9 Tighten the horizontal alignment nut on the IFU mounting bracket.

► **To commission the far-end IFU:**

- 1 Ensure the far-end IFU transmitter is set to ON.



---

**WARNING:** Beware! Radio transmitter is ON when the red light indicator on back side of Invisible Fiber™ unit is illuminated. Observe all radio frequency energy exposure and service interruption cautions.

**MISE EN GARDE :** Attention ! Le poste émetteur est EN MARCHE lorsque le témoin rouge sur le dos de l'unité Invisible Fiber<sup>MD</sup> est allumé. Respecter toutes les mises en garde concernant l'exposition aux radiofréquences et l'interruption de service.

---



---

**WARNING – RF EXPOSURE HAZARD:** Ensure the safety of all personnel. Do not stand in front of the Invisible Fiber™ unit (antenna) in order to avoid possible harmful radio frequency energy exposure. Serious bodily injury may result.

**MISE EN GARDE – RF EXPOSURE HAZARD :** Assurer la sécurité de tout le personnel. Ne pas rester debout devant l'unité Invisible Fiber<sup>MD</sup> (l'antenne) afin d'éviter toute exposition dangereuse aux radiofréquences. Les lésions corporelles sérieux s'ensuivre.

---

- 2 Loosen the four vertical screws on the IFU mounting bracket.
- 3 While viewing the multimeter, sweep the IFU vertically by pointing the IFU all the way up and then down. The measured voltage of the multimeter displays a succession of peak signals as the IFU moves. Specifically, the signal displays a “small” peak, a relatively higher peak, and then redisplay the “small” peak. Note the approximate position of the IFU when the higher peak occurs and the corresponding voltage value. The peak voltage should be approximately 3 Vdc.

- 4 Move the IFU to the higher peak position as indicated by the multimeter display.
- 5 Tighten the four vertical screws on the IFU mounting bracket.
- 6 Loosen the horizontal alignment nut on the IFU mounting bracket.
- 7 Sweep the IFU from the far left to the far right. The measured voltage of the multimeter displays a succession of peak signals as the IFU moves. Note the approximate position of the IFU when the higher peak occurs and the corresponding voltage value.
- 8 Move the IFU to the higher peak position as indicated by the multimeter display.
- 9 Tighten the horizontal alignment nut on the IFU mounting bracket.
- 10 Access the IFU Link Manager application and enable **Power Control** for both the near-end and the far-end IFUs (see IFU Link Manager online help).
- 11 Record the minimum, maximum, and actual RSSI levels set for the IFU in Table A-3 and Table A-5.
- 12 Turn off the laptops, disconnect the test cables, and replace the protective caps on the IFU test connectors.
- 13 Secure all IFU cabling with UV-rated tie-wraps. Continue to tie wrap the cables every 18 inches until they enter the building.

## SONET OC-3 Link Performance Test

This test verifies the continuity of the optical fiber signal path end to end.

► **To perform the Link Performance Test:**

- 1 Configure both SONET test sets for OC-3 testing and connect fiber patch cables as shown in Figure 4-3.
- 2 Test sets will sync up with each other and run head to head. Record the results in Table A-5.
- 3 Configure both SONET test sets for DS-3 testing and connect fiber patch cables as shown in Figure 4-3.
- 4 Test sets will sync up with each other and run head to head. Record the results in Table A-5.

- 5 Set up both SONET test sets for DS-1 testing.
- 6 Test sets will sync up with each other and run head to head. Record the results in Table A-5.
- 7 A frame/bit error can be injected and received to further demonstrate a good path during all tests.
- 8 If all tests run error free and the cabling and termination are correct, all tests pass.

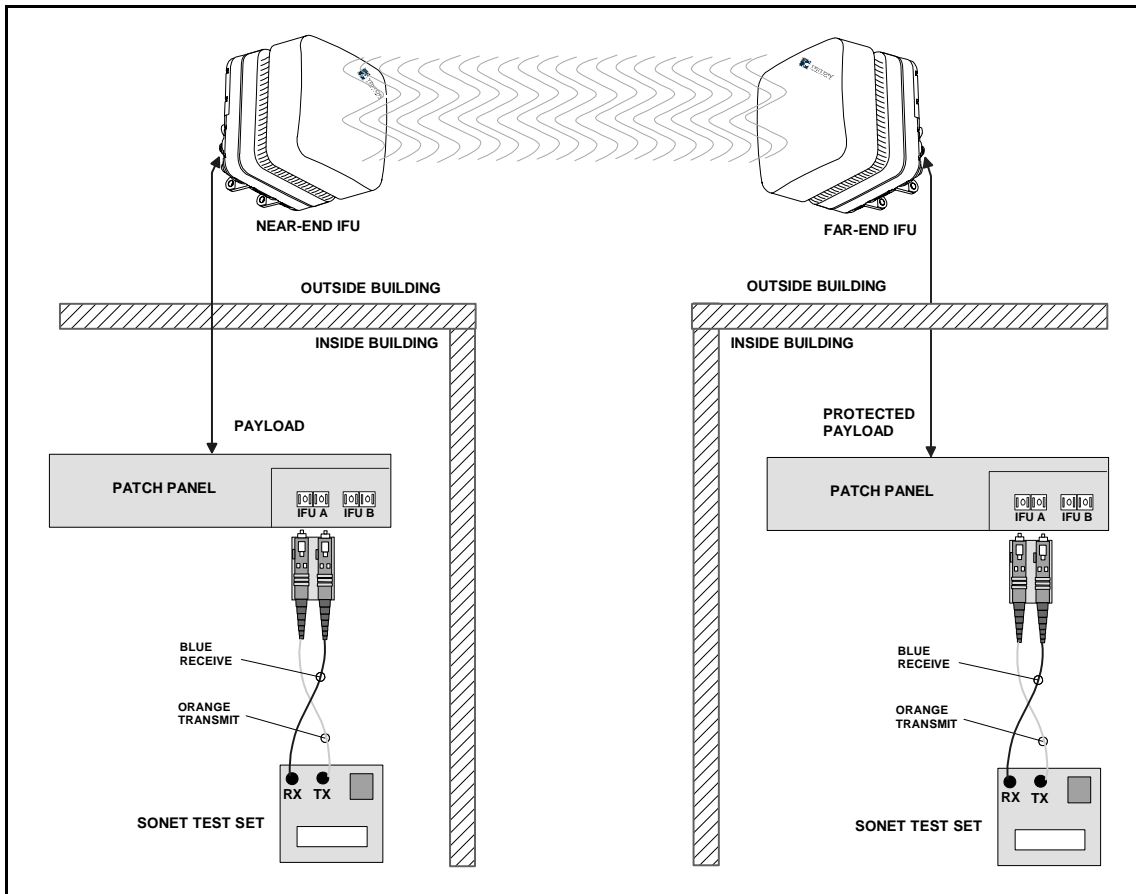

Figure 4-3. SONET Link Test Setup





# Removing an IFU

This chapter provides the procedures for removing an IFU.

---

**NOTE:** Observe all federal and local laws, regulations, electrical codes, building codes, fire codes, and licensing agreements.

Il faut respecter l'ensemble des lois, règlements, codes d'électricité, codes du bâtiment et codes des incendies du gouvernement fédéral et des municipalités ainsi que tous les contrats de licence.

---

**NOTE:** Failure to follow the installation procedure described in the Triton Network Systems' product documentation may result in damage to the Invisible Fiber™ unit and render the unit unusable. Read through the entire installation procedure before beginning installation.

L'inobservation de la procédure d'installation décrite dans la documentation du produit fournie par la société Triton Network Systems peut endommager l'unité Invisible Fiber<sup>MD</sup> et la rendre inutilisable.

---

**CAUTION:** The Invisible Fiber™ unit contains no owner or user serviceable parts. Opening the radio unit or tampering with any of its seals voids all warranties.



**MISE EN GARDE :** L'unité Invisible Fiber<sup>MD</sup> contient pas de parts utilisés par le propriétaire ou l'utilisateur. Ouverture de l'unité de la radio ou toucher aux scelles rend toute garantie nulle et non avenue.

---

The following topics are included in this chapter:

- Servicing an IFU
- Removing an IFU

## Servicing an IFU

Servicing an IFU is done at the factory. To service the IFU, remove it and replace it with a new IFU. Send the IFU needing service to the factory.

## Removing an IFU

Removing an IFU is a two-part process:

- 1 Removing the power and cables from the IFU.
- 2 Removing the IFU from the mounting bracket.

## Removing Cables

- To remove power and cables from the IFU:



**CAUTION:** Ensure that the – 48 Vdc power source is set to the OFF position before attaching power cables to the Invisible Fiber™ Unit.

**MISE EN GARDE :** S'assurer que le bloc d'alimentation – 48 V CC est en position HORS TENSION avant d'attacher les câbles d'alimentation à l'unité Invisible Fibermd.

---



**WARNING:** Never touch exposed fiber with any part of your body. Fiber fragments can enter the skin and are difficult to detect and remove.

**AVERTISSEMENT :** Ne jamais laisser une fibre nue entrer en contact avec une partie quelconque du corps. Des fragments de fibre peuvent entrer dans la peau, et sont difficiles à déceler et à enlever.

---



---

**CAUTION:** Ensure the outside optical fiber connectors are environmentally protected. Failure to do so may cause contamination of the fiber surfaces.



**MISE EN GARDE :** S'assurer que les raccords extérieurs fibre optique sont protégés contre l'environnement. L'absence d'une telle protection peut entraîner la contamination des surfaces des fibres.

---

- 1 Set the – 48 Vdc power source to the OFF position.
- 2 Remove the power and fiber optic cables from the IFU locations as shown in Figure 5-1.

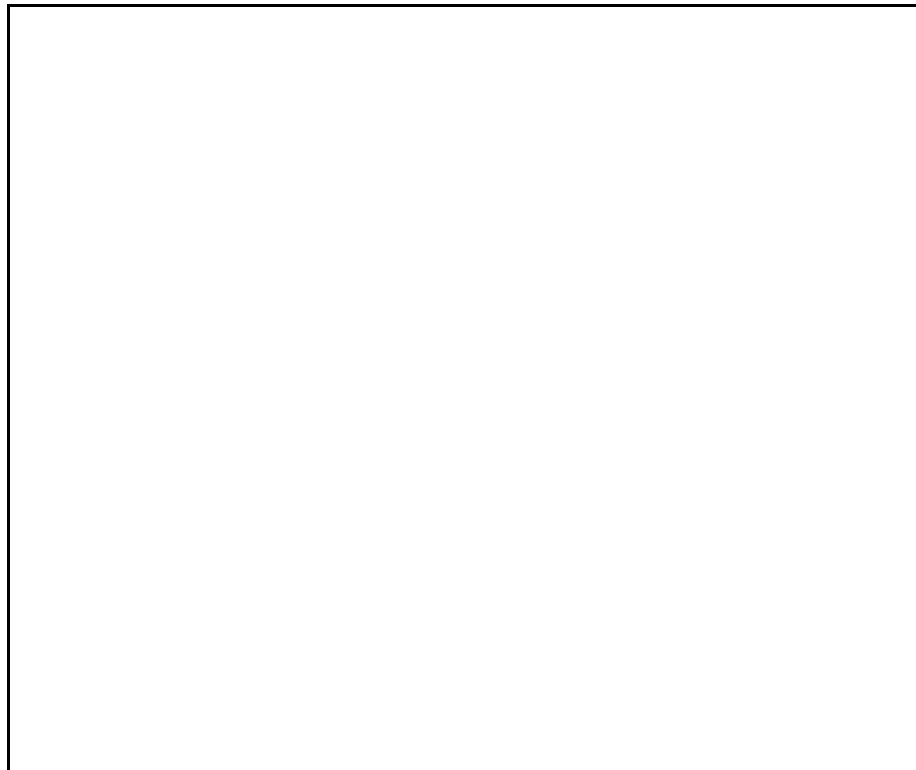

**Figure 5-1.** IFU Cable Connections

## Removing an IFU from a Mounting Bracket

► **To remove an IFU from its mounting bracket:**

- 1 Remove the nut (6), lock washer (5), flat washer (4), and earth ground strap from the bottom bolt of the mounting bracket (1) (see Figure 5-2).



---

**CAUTION:** Lifting hazard: Two people are required to lift the Invisible Fiber™ unit. Grasp the Invisible Fiber™ unit underneath the lower edge and lift with both hands. To prevent injury, keep your back straight and lift with your legs, not your back. To prevent damage to the Invisible Fiber™ unit and components, never attempt to lift the radio by the attached cables.

**MISE EN GARDE :** Danger de levage. Il faut deux personnes pour soulever l'unité Invisible Fiber<sup>MD</sup>. Saisir l'unité Invisible Fiber<sup>MD</sup> au-dessous du rebord inférieur, puis soulever l'unité avec les deux mains. Pour éviter les lésions corporelles, garder le dos en position verticale et soulever l'unité en utilisant les jambes et non pas les reins. Pour éviter l'endommagement de l'unité Invisible Fiber<sup>MD</sup> et de ses composants, ne jamais essayer de soulever la radio en tirant sur les câbles qui y sont attachés.

---



---

**CAUTION:** Keep tools and parts away from walkways. When carrying large, heavy equipment (such as the Invisible Fiber™ Unit), obstacles (such as hand tools, cables or components) may not be easily visible and can cause accidents.

**MISE EN GARDE :** Garder les outils et les pièces loin des allées. Lorsqu'on transporte des équipements lourds et à grandes dimensions (tels que l'unité Invisible Fiber<sup>MD</sup>), les obstacles (tels que les outils à main, les câbles ou les composants) sont parfois difficiles à voir et peuvent causer des accidents.

---

- 2 Remove two snap rings (3) from mounting studs (7) as shown in Figure 5-2.
- 3 Disengage the top IFU clamp and remove the IFU (2) from the mounting bracket (1) as shown in Figure 5-2.
- 4 Replace dust caps on exposed IFU and cable connectors.

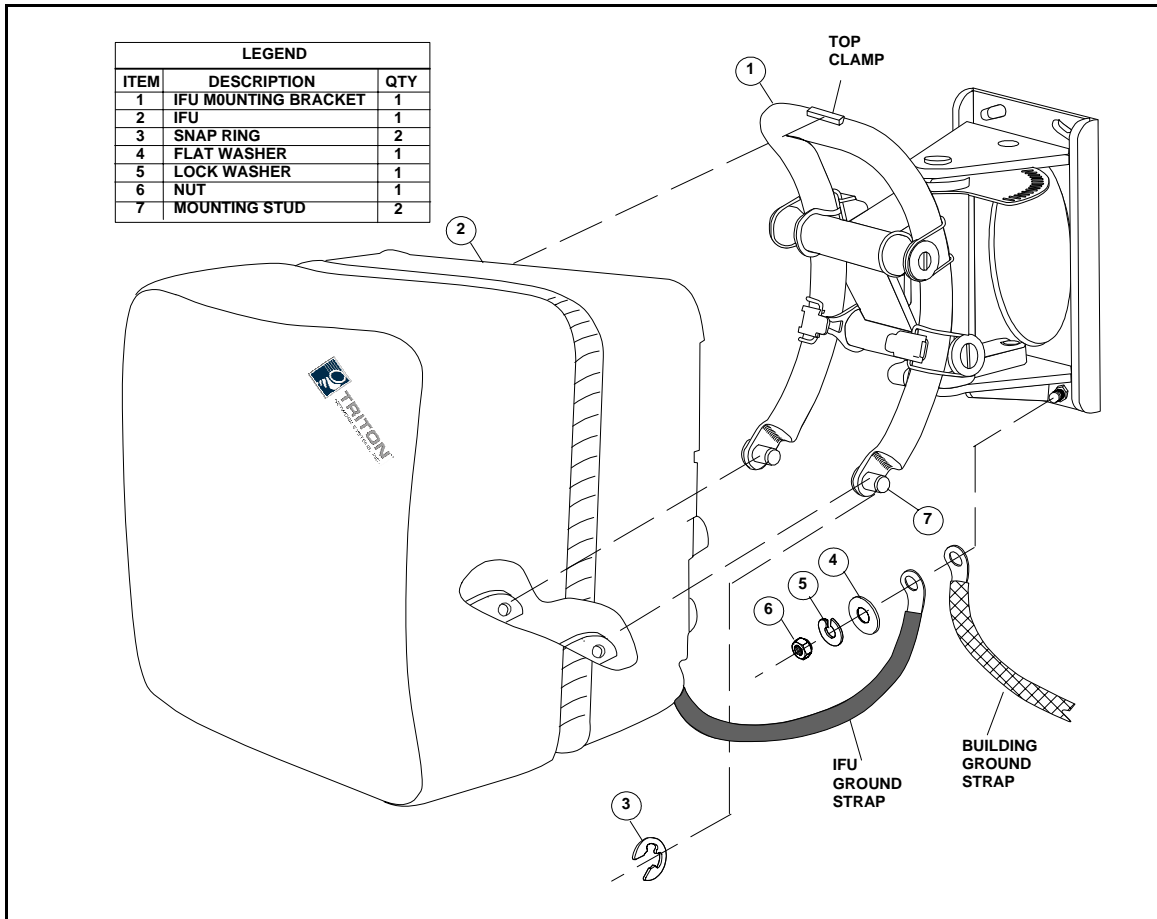

Figure 5-2. IFU Removal

- 5 To install a new IFU see *Mounting the IFU* on page 3-18 and *Attaching IFU Cables* on page 3-21.

## Packing the IFU for Shipment

Use the original packing material to ship the IFU to the factory. Should the packing material not be available, contact Triton Network Systems (see *Contacting Triton Network Systems, Inc.* on page xiii) for packing instructions.





# IFU Test Results

This appendix contains tables for recording the power, fiber optic, and commissioning test data.

## Power Source Tests

**Table A-1.** Power Supply Test Results

Pins	Results	Pass Criteria	Pass/Fail
IFU Alpha - A & C		- 46 Vdc to - 56 Vdc	
IFU Alpha - B & H		- 46 Vdc to - 56 Vdc	
IFU Beta - A & C		- 46 Vdc to - 56 Vdc	
IFU Beta - B & H		- 46 Vdc to - 56 Vdc	
IFU Gamma - A & C		- 46 Vdc to - 56 Vdc	
IFU Gamma - B & H		- 46 Vdc to - 56 Vdc	

## SONET OC-3 Fiber Optic Test

**Table A-2.** SONET OC-3 Fiber Optic Test Results

IFU Alpha Test Adapter End	Fiber Signal Strength >-7.4 dBm @ 1310 nm	IFU Beta Test Adapter End
IFU Alpha Interconnect TX		IFU Beta Interconnect RX
IFU Alpha Interconnect RX		IFU Beta Interconnect TX

## Far-End Test

**Table A-3.** Far-End Test Results #1

IFU Number	Min/Max Signal Strength	IFU Signal Strength Set	Pass/Fail

**Table A-4.** Far-End Test Results #2

IFU Number	Min/Max Signal Strength	IFU Signal Strength Set	Pass/Fail

## Near-End Test

**Table A-5.** Near-End Test Results #1

IFU Number	Min/Max Signal Strength	IFU Signal Strength Set	Pass/Fail

**Table A-6.** Near-End Test Results #2

IFU Number	Min/Max Signal Strength		IFU Signal Strength Set	Pass/Fail

## SONET OC-3 Link Performance Test

**Table A-7.** SONET OC-3 Link Performance Test

Test	Errors Received (Expect 0 Errors)	Errors Sent (Expect 0 Errors)
OC-3		
DS-1		
DS-3		







# Invisible Fiber™ Product Glossary

## 10BaseFL

Part of the IEEE 802.1j standard for 10 Mbps Ethernet fiber.

## 10BaseT

IEEE 802.3 standard specifying Ethernet over unshielded twisted pair cables.

## 99.999% availability

(Also known as five 9s availability.) Amount of time the system is expected to be available. If the system is available 99.999% of the time, expected down time is approximately six minutes per year, derived as follows:

$$\begin{aligned} \text{Days per year} \times \text{hours per day} \times (100 - 99.999) \div 100 \times 60 &= \\ 365.25 \times 24 \times (100 - 99.999) \div 100 \times 60 &= 5.2 \text{ minutes} \end{aligned}$$

## 100BaseFX

Part of the IEEE 802.3u standard for 100 Mbps Ethernet over fiber.

A

## Add/Drop Multiplexer (ADM)

A device that provides an interface between the different signals in a digital T-carrier or SONET network. When an ADM is inserted in a transmission line, it enables lower rate signals to be extracted (dropped) and transported differently (electrical or optical). Similarly, a lower rate signal can be inserted (added) into a higher rate signal.

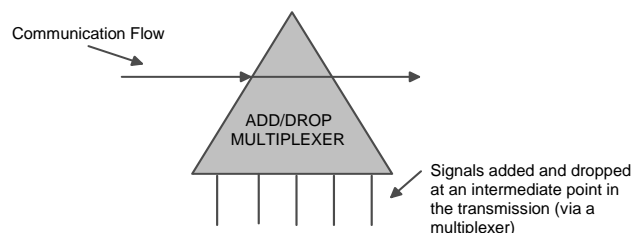

---

**ADM**

See *Add/Drop Multiplexer (ADM)*.

**AIS**

See *Alarm Indication Signal (AIS)*.

**Alarm Indication Signal (AIS)**

A special signal that is transmitted to downstream equipment for specific equipment fault conditions.

**antenna**

A mechanical device that can convert electrical signals to and from electromagnetic waves. An IFU contains an antenna.

**Asynchronous Transfer Mode (ATM)**

A cell-based protocol, developed by the ITU-T, for transmitting and switching voice, video, and data traffic. ATM technology does not use a fixed timing reference, hence the name asynchronous.

**ATM**

See *Asynchronous Transfer Mode (ATM)*.

**atmospheric absorption**

Amount of energy lost when radio waves are transmitted due to the presence of atmospheric gases.

**attenuation**

The reduction in the strength of a signal measured in dB. See also *propagation loss*.

**azimuth**

The horizontal angle the radiating lobe of an antenna makes. When you adjust an IFU by its azimuth, you move it on its horizontal plane (left to right or right to left).

**B****backbone**

A backbone is the transport path that provides connectivity to other paths. On the Internet or a WAN, the backbone is a series of paths to which local, regional, or global networks connect.

---

**backhaul**

A transmission path used to move traffic to/from a remote location from/to a central location. The message can be routed “out of its way” so that it arrives at its destination more quickly. A network can perform a back haul transmission if a direct communication link is busy and an indirect link would be faster. (The verb form is *back haul*.)

**bandwidth**

The range of frequencies over which a signal is transmitted.

**BER**

See *Bit Error Rate (BER)*.

**Bit Error Rate (BER)**

The number of bit errors detected – displayed as the ratio of the average number of errored bits in a given number of bits sent. The BER is used to measure transmission quality. For example, a BER of  $10^{-12}$  is equivalent to one error in a trillion bits, which means that for:

- SONET OC-3, one error bit is detected approximately every 1.8 hours
- Fast Ethernet, one error bit is detected approximately every 2.8 hours.

**BNC connector**

Bayonet Neil-Concelman connector. A bayonet type of connector for coaxial cables in an Ethernet network.

**C****Central Office (CO)**

Location at which one or more switches reside for aggregating voice or data traffic.

**Central Processing Unit (CPU)**

Central controller that coordinates functions in the IFU.

**channel**

Physical medium through which signals are transmitted. In optical fiber transmissions, a channel is a separate wavelength of light within a combined multiplexed light stream.

**channelization**

Logically subdividing a frequency (normally assigned by a regulatory agency for the delivery of broadband wireless services).

---

**CLEC**

Independent company that competes with the already established local telephone company by providing its own network and switching. CLEC distinguishes a new or potential competitor from an established local exchange carrier (LEC). The term originated from the Telecommunications Act of 1996, which was intended to promote competition among long-distance and local phone service providers.

**CO**

See *Central Office (CO)*.

**cochannel interference**

Interference between signals transmitted within one radio frequency channel.

**colocation**

Space set aside for a customer's telecommunications equipment on the service provider's premises. For example, a web site owner could place its computer server on the premises of an ISP, or an ISP could locate its network router at a company that supplies switching services to other ISPs.

**Competitive Local Exchange Carrier**

See *CLEC*.

**commissioning**

Tasks required to enable equipment to be placed in a live network. IFU commissioning tasks include configuration and antenna alignment.

**configuration management**

The process of setting equipment attributes that enables equipment to function as intended.

**consecutive point**

Network architecture implemented via a point-to-point-to-point design.

**CPE**

See *Customer Premise Equipment (CPE)*.

**CPU**

See *Central Processing Unit (CPU)*.

**Customer Premise Equipment (CPE)**

Equipment (such as telephones and computers) installed at a customer's office.

**customer site**

Network equipment configuration for a location at which network access is provided in a carrier's consecutive point network.

---

**Crane rain model**

System of formulas, charts, and maps developed by Robert K. Crane to depict a global prediction of attenuation caused by rain. See also *rain attenuation*.

**D****dB**

Decibel. The unit of measurement for signal strength, usually the ratio between a transmitted signal and a standard signal source.

**decibel (dB)**

See *dB*.

**demarcation point**

Logical dividing point between equipment and a network.

**E****Element Management System (EMS)**

Software application used to manage network equipment.

**EMS**

See *Element Management System (EMS)*.

**Ethernet**

Generic term for the IEEE 802.3 standard network transmission protocol.

**exciter**

An oscillator that enables a tuner to change its frequency.

**F****fade margin**

Amount of signal reduction a receiver can tolerate and continue to maintain satisfactory performance.

**far-end IFU**

- a) IFU at the other end of the link in the network (during site evaluation).
  - b) Second IFU installed in a linked pair of IFUs.
- See also *near-end IFU*.

**Fast Ethernet**

Generic term for a IEEE standard network 100 Mbps transmission protocol.

**fault management**

Software that reports and identifies the source of network faults.

---

**fiber optics**

Technology in which information is transmitted as light impulses from one point to another through extremely thin glass or plastic wire or fiber.

**fixed wireless system**

Communication system that uses radio spectrum to provide services to locations that are not mobile.

**forward error correction**

A system in which redundant information is generated at the transmitted end so that the receiving unit can detect, locate, and correct any errors before delivering the transmission.

**free space propagation loss**

Normal signal attenuation of radio waves transmitted through free space. Free space loss increases logarithmically with increased hop distance.

**Fresnel zone**

A defraction zone around the line-of-sight path between two points as shown in the following illustration.

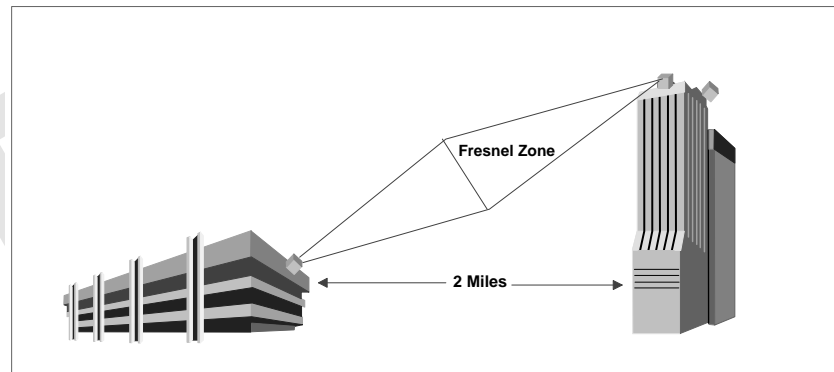

The line-of-sight, including the Fresnel zone, must be clear of obstructions to ensure communication between the IFUs.

**G****gateway**

A network point that aggregates traffic and acts as an entrance to another network.

**gateway site**

Network equipment configuration for a location that aggregates customer traffic in a consecutive point network for access to and from the Internet.

**general purpose input/output**

See *GPIO*.

---

## **GPIO**

General Purpose Input/Output. Input/output ports on the IFU that provide external control of equipment or detection and generation of external alarms. Each IFU contains four GPIO ports (two input-only and two output-only).

## **H**

### **histogram**

A graphical representation of the distribution of a performance parameter. For example, a histogram can show the value and proportion of time a particular transmit power is used on a link.

### **hop distance**

The distance between two communicating IFUs. One objective in network design is to design link hop distances so that the RF path loss does not exceed the path loss allowance for the required availability or grade of service.

### **HP OpenView™**

Hewlett Packard's network management product consisting of a suite of software tools that enable network operations staff to manage the elements in a network. HP OpenView Network Node Manager™ and the IFU Link Manager software provide complete element management functions for an IFU network.

### **hub**

A location in a network where data is aggregated and forwarded to its destination. A hub contains a switch and a router.

## **I**

### **IFU**

Invisible Fiber™ unit. Outdoor fixed-wireless device, designed to fiber-optic specifications, that combines antenna, transceiver, modem, and controller modules to transport high-bandwidth network-grade broadband telephony and data services.

### **IFU Link Manager**

Triton Network Systems' software application that provides fault, performance, configuration, and security management functions, enabling onsite technicians and network management staff to configure and monitor IFUs.

### **ILEC**

Incumbent Local Exchange Carrier. Generic term for the carrier that telephone company in the U.S. that was providing local service when the Telecommunications Act of 1996 was enacted.

---

**In Service (IS)**

System status indicating that an IFU is working with no known problems.

**Incumbent Local Exchange Carrier**

See *ILEC*.

**indoor repeater site**

Location used to extend a consecutive point network to enable future customer access.

**Internet Protocol**

See *IP*.

**Internet Service Provider (ISP)**

An operator that provides its customers access to the Internet.

**Invisible Fiber™ unit**

See *IFU*.

**IP**

Internet Protocol. A connectionless network layer protocol used for forwarding individual packets from one intermediate destination (typically a router) to another on the way to their final destination.

**IS**

See *In Service (IS)*.

**ISP**

See *Internet Service Provider (ISP)*.

**ITU rain model**

System of formulas, charts, and maps developed the International Telecommunication Union (ITU) to characterize rain attenuation.

**J****Java™**

A C++-like, object-oriented programming language, created by Sun Microsystems and used to build client and server applications that run on any hardware platform where a Java virtual machine resides.

**Java™ Runtime Environment**

See *JRE*.

**JRE**

Java™ Runtime Environment. Software platform that enables Java applications to execute. The IFU Link Manager software requires JRE.



---

## **Java™ virtual machine**

Software, created for specific hardware platforms (microprocessors), that interprets compiled Java code (bytecode) using the microprocessor's set of instructions. Java virtual machines enable any Java application (bytecode) to run on any platform without requiring the programmer to rewrite or recompile the application for each platform.

## **L**

### **LAN**

Local Area Network. Integrated data communication network (linking computers and peripheral devices) designed to provide services to a closed user community. See also *MAN* and *WAN*.

### **line-of-sight**

Straight line of space between a transmitter and receiver. The space between a transmitter and receiver must be clear of obstructions because the transmission media (such as microwave, infrared, and laser) travel in a perfectly straight line.

### **link angles**

GPS coordinates of the angle for an IFU linked pair.

### **link budget**

The sum of transmission losses between transmitter and receiver. The total should be equal to or less than the system gain. The link budget is configured using the transmitted signal power and signal-to-noise ratio (SNR), the antenna gains, implementation degradation, and the noise figure of the receiver.

### **link manager**

See *IFU Link Manager*.

### **LMDS**

See *Local Multipoint Distribution System (LMDS)*.

### **Local Area Network (LAN)**

See *LAN*.

### **Local Multipoint Distribution System (LMDS)**

Broadband wireless spectrum over which telephony and data services are delivered.

### **loop back**

Directing signals back toward the transmitting device at some point along the communications path. Used as a method for troubleshooting.

---

## M

### **MAN**

Metropolitan Area Network. Integrated data communication network within a city. See also *LAN* and *MAN*.

### **Management Information Base**

See *MIB*.

### **MIB**

Management Information Base. A collection of statistics and variables residing on an SNMP-managed device. The statistics allow collection of performance data and the variables allow configuration of the device.

### **microwave radio**

Device that uses microwave frequencies (3–300 GHz) for consecutive point communication.

### **Millimeter Wave**

See *MMW*.

### **MMIC**

See *Monolithic Microwave Integrated Circuit*.

### **MMW**

Millimeter Wave. The frequency range between 30 and 300 GHz.

### **modem**

MOdulator, DEModulator. A device that converts between analog and digital signaling.

### **modulation**

Act of encoding information onto a carrier signal.

### **Monolithic Microwave Integrated Circuit**

Integrated circuit technology that provides two-watt linear power at the Tx port of the RF power amplifier.

### **multiplexer**

Device that aggregates traffic into a single medium.

## N

### **NE**

Network Element. Single piece of equipment in the network.

---

**near-end IFU**

- a) IFU at the location being evaluated.
  - b) First IFU installed in a linked pair of IFUs.
- See also *far-end IFU*.

**Network Element**

See *NE*.

**Network Interface Card**

See *NIC*.

**network management**

The policies, procedures, and tools that enable an operator to monitor and manage network elements.

**Network Management System (NMS)**

Integrated, comprehensive system of equipment used for monitoring and managing network elements.

**Network Operations Center (NOC)**

Location at which monitoring and management of a network might take place.

**network provisioning**

Act of configuring IFU network hardware and software to make the network operational.

**NIC**

Network Interface Card. Interface between physical transmitter layer and modem.

**NMS**

See *Network Management System (NMS)*.

**NOC**

See *Network Operations Center (NOC)*.

**NREP**

Not REPorting. System status indicating the IFU is not reporting alarms because an operator has suspended alarm reporting.

**NRES**

Not RESponding. System status indicating the IFU is not responding to poll messages from HAMLET.

---

## O

### **OAM&P**

Operations, Administration, Maintenance, and Provisioning. Describes a piece of equipment or personnel required to manage a network.

### **OC-3**

Optical Carrier level 3. Optical signal designed to receive and transmit SONET. A pure OC-3 SONET channel carries 155.52 Mbps.

### **OC-12**

Optical Carrier 12. Optical signal designed to receive and transmit SONET. A pure OC-12 SONET channel carries 622.08 Mbps.

### **OC-48**

Optical Carrier level 48. Optical signal designed to receive and transmit SONET. A pure OC-48 SONET channel carries 2.4 Gbps.

### **OOS**

Out Of Service. System status indicating that the IFU is currently not in service and is not expected to recover on its own. Service is required.

### **operating system**

See *OS*.

### **OS**

Operating System. Program that loads when a computer is booted and manages all the other applications in the computer.

### **outdoor repeater site**

Location used to extend a consecutive point network.

## P

### **password**

A string of characters entered by a user, typically in a Login screen, to gain access to a computer system.

### **path loss allowance**

The net amount of amplification given to the signal in an IFU link, including margins for adequate received SNR and channel fading. In other words, path loss allowance is equal to the system gain plus the antenna gains.

### **payload**

User traffic transported over a network

---

**Point Of Presence (POP)**

Umbrella name referring to the location of the physical access point where user traffic is aggregated.

**polarization**

Directional orientation of a radio wave electric field. Some radio communication systems can exploit polarization differences to reduce interference from nearby links.

**POOS**

Potentially Out Of Service. System status indicating that the IFU is in service, but may be out of service in the future. Service may be required.

**POP**

See *Point Of Presence (POP)*.

**power source**

A separate unit or part of a circuit that supplies power to the rest of the circuit or to a system.

**propagation loss**

Signal attenuation that occurs during transmission.

**provisioning**

Act of configuring the gateway routers and the site equipment to enable a customer to receive service.

**Q****QAM**

Quadrature Amplitude Modulation. Transmitted signal defined by amplitude and phase.

**R****Radio Frequency (RF)**

An electromagnetic wave frequency from approximately 3 KHz to approximately 300 GHz. Includes the frequencies used for radio and television transmission.

**radio overhead**

IFU communication channel in addition to the payload.

**rain attenuation**

Transmit signal loss due to rain.

---

**Received Signal Strength Indicator**

See *RSSI*.

**receiver**

Telecommunication equipment device that captures and converts a transmitted signal to the required format.

**reference oscillator**

A device that generates a precise radio frequency signal to be used as a reference.

**RF**

See *Radio Frequency (RF)*.

**RF spectrum**

Range of available radio frequencies.

**router**

A layer-3 physical device that aggregates and directs network traffic based on TCP/IP.

**RS-232**

Recommended standard physical interface (connector) for electrical, functional, and mechanical communication interfaces between computers, terminals, and modems.

**RSL**

See *RSSI*.

**RSSI**

Received Signal Strength Indicator (also known as RSL, Received Signal Level). A measured value from a receiver describing the received signal level or strength.

**S****security management**

System to protect a network from invalid access.

**Signal Quality Metric (SQM)**

Ratio of bit energy to noise power spectral density. The SQM value relates to transmission and receiver signal quality.

**Simple Network Management Protocol**

See *SNMP*.

---

**site drawing**

Graphic depiction, which shows the location of all IFU-related components drawn by a contractor and designee. A site drawing is a component of a site engineering folder.

**site engineering folder**

Documentation generated by Triton Network Systems based on the information gathered during the site survey and product requirement specifications.

**SNMP**

Simple Network Management Protocol. An industry standard protocol used to communicate between elements and management systems in a network.

**SONET**

Synchronous Optical NETWORK. Standard protocol that defines a group of fiber-optic transmission rates that can transmit various bit-rate signals inside a broadband synchronous signal. SONET was designed to allow for a multi-vendor environment.

**SNR**

Signal-to-Noise Ratio. The SNR measures the quality of the intended signal versus any background noise. Usually expressed in decibels (dB).

**SQM**

See *Signal Quality Metric (SQM)*.

**staging**

Installation phase during which equipment might be integrated and made ready for deployment.

**switch**

A network device that selects the path for sending traffic to its next destination.

**Synchronous Optical NETWORK**

See *SONET*.

**system gain**

The ratio of transmit power to receiver sensitivity, usually expressed in dB. This ratio usually does not include antenna gain.

---

## T

### **TCM**

Trellis Coded Modulation. The goal of TCM is the same as other error correction schemes – to increase data rate by adding redundancy to reduce error. TCM uses redundancy to enhance the signal detection process.

### **TCP/IP**

Transmission Control Protocol/Internet Protocol. Family of data communication protocols universally implemented on the Internet. TCP is a transport layer protocol used for reliable, connection-oriented communication between two applications. SNMP is a commonly used protocol in the TCP/IP family.

### **TOOS**

Temporarily Out Of Service. System status indicating the IFU is out of service, but is expected to recover without human intervention.

### **transceiver**

Abbreviation for a transmitter and receiver.

### **transmitter**

Device that converts signals for transmission.

### **Trellis encoding rate**

Rate of TCM. (See *TCM*.)

### **Tx**

Transmitted signal or transmitter.

## V

### **Virtual Private Network**

See *VPN*.

### **VPN**

Virtual Private Network. Private network that is built on top of a public network.

## W

### **WAN**

Wide Area Network. High-speed network that connects networks over a large geographical area. (See also *LAN* and *MAN*.)

### **Wide Area Network**

See *WAN*.



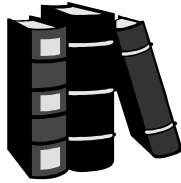

# Index

## A

aligning  
near-end IFU 4-3

## B

bracket  
attached to wall 3-3  
mounting 3-3  
pole mount 3-4  
removing IFU from 5-4

## C

cable 1-2  
connections 3-21  
fiber optic 1-2  
continuity test 3-14–3-18  
continuity test results form A-2  
power 1-2  
input test 3-7–3-8  
input test results form A-1  
verify connection 2-4–2-5  
removing 5-2  
verify connection  
setup 2-4  
cautions  
personal injury xvii  
convention xv  
service interruption xviii  
convention xv  
cleaning  
fiber optic cable  
procedure 3-15  
commissioning  
setup 4-2

commissioning tools 4-2  
components  
fiber optic cable, installing 3-9  
IFU bracket, mounting 3-3  
power cables, installing 3-5  
configuration 2-1  
defined 2-1  
parts list 2-1  
procedure 2-2  
setup 2-6  
staging area  
contacting Triton Network Systems, Inc. xiii  
conventions  
warnings and safety  
English xv  
fiber optic warning xv  
French xxi  
risk of electrical shock xv  
risk of personal injury xv  
risk of radio frequency energy exposure  
xv  
risk of service interruption xv

## D

danger  
fiber optics xvi  
high current hazard xvi  
high voltage hazard xvi  
demarcation jumper cables 3-14  
demarcation panel  
connections 3-11

## E

earth ground 1-3

---

electrical shock warnings xvi  
convention xv  
engineering folder 1-1

## F

far-end IFU  
defined 3-18  
test 4-8  
results form A-2  
fiber optic cable 1-2  
cleaning procedure 3-15  
configuration 1-4  
continuity test 3-14–3-18  
results form A-2  
installing 3-9  
testing procedure 3-16, 3-21  
fiber optic warnings xvi  
convention xv

## G

grounding system  
earth ground 1-3

## I

IFU  
aligning near-end 4-3  
bracket  
*See* bracket  
commissioning  
far-end 4-6  
far-end test 4-8  
far-end test results form A-2  
near-end test results form A-2  
installing 3-18  
mounting 3-18  
part number 2-2  
pole setup 3-4  
power termination  
wiring diagram 3-7  
removing from bracket 5-4  
servicing 5-2  
wall mount setup 3-3  
IFU Link Manager  
defined 1-2  
for commissioning 4-2  
installation

attaching cables to IFU 3-21  
cable requirements 1-2  
fiber optic cable 3-9  
IFU 3-18  
IFU components 3-3  
fiber optic cable 3-9  
power cable 3-5  
mounting IFU on bracket 3-18  
overview 1-1  
power cables 3-5  
power source requirements 1-2  
setup 3-2

## J

jumper  
demarcation box connections 3-14  
jumper cables  
demarcation 3-14

## L

lifting guideline 2-3  
lightning suppression 1-3  
link performance test 4-8  
results forms A-3  
setup 4-9

## M

maintenance 5-2  
mises en garde xxv  
mounting  
IFU 3-18  
IFU bracket 3-3

## N

National Electrical Code (NEC) 1-3  
near-end IFU  
aligning 4-3  
defined 3-18  
test  
results form A-2

## O

optical fiber  
*See* fiber optic

---

## P

- part number 2-2
- parts list
  - configuration 2-1
  - site installation 3-2
- performance test, link 4-8
  - results forms A-3
- performance test, link setup 4-9
- personal injury
  - cautions xvii
  - electrical shock warnings xvi
  - fiber optics warnings xvi
- pole mount 3-4
- power cable 1-2
  - hookup 2-4
  - IFU power termination
    - wiring diagram 3-7
  - input test
    - setup 3-8
  - installing 3-5
  - test
    - results form A-1
  - verify connection 2-4–2-5
  - wiring diagram 3-6
- power source 1-2
- precautions xix
- procedure
  - aligning near-end IFU 4-3
  - configuration 2-2
  - fiber optic cable
    - cleaning 3-15
    - testing 3-16, 3-21
  - installing fiber optic cable 3-9
    - cleaning 3-15
    - testing 3-16, 3-21
  - installing power cables 3-5
  - link performance test 4-8
  - mounting IFU bracket 3-3
  - removing cables 5-2
  - removing IFU from bracket 5-4

## R

- radio frequency
  - energy exposure
    - convention xv
    - warnings xvi
- removing
  - IFU cables 5-2

- IFU from bracket 5-4

## risk

- electrical shock
  - convention xv
  - warnings xvi
- fiber optics
  - convention xv
  - warnings xvi
- other precautions xix
- personal injury
  - cautions xvii
  - convention xv
- radio frequency energy exposure
  - convention xv
  - warnings xvi
- service interruption
  - cautions xviii
  - convention xv

## risque

- câbles à fibres optiques xxii
  - convention xxi
- d'interruption de service xxiv
  - convention xxi
- de lésions corporelles xxiii
  - convention xxi
- décharge électrique xxii
  - convention xxi
- l'exposition de l'énergie radiofréquences xxiii
  - convention xxi

## S

- service 5-2
- setup
  - commissioning IFUs 4-2
  - configuration 2-6
  - installing IFUs 3-2
  - pole mounted bracket 3-4
  - verify connection 2-4
  - wall mounted bracket 3-3
- site engineering folder 1-1
- site equipment cabinet
  - inputs 3-13
- site installation
  - parts list 3-2
  - tools 3-2
- SONET 1-2
- staging
  - See* configuration

---

surge suppression 1-3  
    defined 1-3  
system grounding  
    *See* grounding system

## T

test  
    far-end IFU 4-8  
        results form A-2  
    fiber optic continuity 3-14–3-18  
        results form A-2  
    link performance 4-8  
        results forms A-3  
        setup 4-9  
    near-end IFU  
        results form A-2  
    power cable 3-7–3-8  
        results form A-1  
        setup 3-8  
    power cable connection 2-4–2-5  
testing  
    fiber optic cable  
        procedure 3-16, 3-21  
tools  
    commissioning 4-2  
    site installation 3-2

## W

wall mount 3-3  
warnings  
    risk from fiber optics xvi  
        convention xv  
    risk of electrical shock xvi  
        convention xv  
    risk of radio frequency energy exposure xvi  
        convention xv