



**TRITON™**  
NETWORK SYSTEMS, INC.

# **Invisible Fiber™ Unit Installation Guide**

for 28 GHz SONET OC-3 Applications

This is a released version of this book. This PDF is for Internal Use Only and is not to be printed and distributed - OR - distributed electronically to anyone outside Triton Network Systems. Only the official hardcopy and electronic (PDFs on CD-ROMs) book products are to be distributed outside Triton Network Systems. Book products can be ordered externally through the Triton Network Systems Sales Order Entry System. Book products can be ordered internally by submitting a Non-Production Material Request form to Manufacturing.

## **Notice of Disclaimer**

The information and specifications provided in this document are subject to change without notice.

The Warranty(s) that accompany Triton Network Systems, Inc., products are set forth in the sales agreement/contract between Triton Network Systems, Inc., and its customer. Please consult the sales agreement for the terms and conditions of the Warranty(s) provided by Triton Network Systems, Inc. To obtain a copy of the Warranty(s), contact Triton Network Systems, Inc., the Marketing Group at +1-407-903-0975 or +1-407-903-0997 (FAX).

The information provided in this Triton Network Systems, Inc., document is provided “as is” without warranty of any kind, either expressed or implied, including, but not limited to, the implied warranties of merchantability, fitness for a particular purpose, or non-infringement. Some jurisdictions do not allow the exclusion of implied warranties, so the above exclusion may not apply to you.

In no event shall any Triton Network Systems, Inc., company be liable for any damages whatsoever—including special, indirect, consequential or incidental damages or damages for loss of profits, revenue, use, or data whether brought in contract or tort, arising out of or connected with any Triton Network Systems, Inc., Document or the use, reliance upon or performance of any material contained in or accessed from this Triton Network Systems, Inc. document. Triton Network Systems’ license agreement may be provided upon request. Additional Terms and Conditions will be finalized upon negotiation of a purchase.

## **Trademark Information**

Invisible Fiber™ is a trademark of Triton Network Systems, Inc.

All other brand or product names are trademarks or registered trademarks of their respective companies or organizations.

Part Number: 5228002-0001



# Contents

<b>List of Figures .....</b>	<b>vii</b>
<b>List of Tables .....</b>	<b>ix</b>
<b>About This Book .....</b>	<b>xi</b>
Purpose of This Book .....	xi
Intended Audience .....	xi
Format of This Book .....	xii
Conventions Used in This Book .....	xii
Contacting Triton Network Systems, Inc. ....	xiii
<b>Warnings and Safety Guidelines .....</b>	<b>xv</b>
Conventions .....	xv
Risk of Personal Injury from Electrical Shock .....	xvi
Risk of Personal Injury from Fiber Optics .....	xvi
Risk of Personal Injury from Radio Frequency Energy Exposure .....	xvi
Other Risks of Personal Injury .....	xvii
Risk of Service Interruption .....	xviii
Other Precautions .....	xix
<b>Avertissements et consignes de sécurité .....</b>	<b>xxi</b>
Conventions .....	xxi
Risque de lésions corporelles provoquées par la décharge électrique .....	xxii
Risque de lésions corporelles provoquées par les câbles à fibres optiques.....	xxii

---

Risque de lésions corporelles provoquées par l'exposition de l'énergie radiofréquences .....	xxiii
Autres risques des lésions corporelles .....	xxiii
Risque d'interruption de service .....	xxiv
Autres mises en garde .....	xxv
<b>Chapter 1 — Installation Overview .....</b>	<b>1-1</b>
Installation Overview .....	1-1
Site Engineering Folder .....	1-1
IFU Link Manager .....	1-2
Power Source .....	1-2
Cabling .....	1-2
Power Cable .....	1-2
Fiber Optic Cable .....	1-2
System Grounding and Surge Protection .....	1-3
Earth Ground .....	1-3
Surge Protection .....	1-3
<b>Chapter 2 — Staging Procedure .....</b>	<b>2-1</b>
Configuring IFUs .....	2-1
<b>Chapter 3 — Installation Procedures .....</b>	<b>3-1</b>
Setup .....	3-2
Before Starting .....	3-2
Preparing for Installation .....	3-2
Installing IFU Components .....	3-3
Determining IFU Mounting Requirements .....	3-4
Wall-Mount Criteria .....	3-5
Pole-Mount Criteria .....	3-5
RF Energy Exposure Safety Limits and Applicable Rules .....	3-6
Mounting the IFU Bracket .....	3-7
Installing Power Cables .....	3-9
IFU Power Cable Test .....	3-11
Installing the Fiber Optic Cable .....	3-13

---

Fiber Optic Continuity Test .....	3-18
Installing an IFU .....	3-22
Attaching IFU Cables .....	3-25
<b>Chapter 4 — Alignment Procedures .....</b>	<b>4-1</b>
Setup .....	4-2
Before Starting .....	4-2
Preparing for Installation .....	4-2
Coarse Aligning the IFU .....	4-3
Fine Aligning the IFU .....	4-7
<b>Chapter 5 — Removing an IFU .....</b>	<b>5-1</b>
Servicing an IFU .....	5-2
Removing an IFU .....	5-2
Removing Cables .....	5-2
Removing an IFU from a Mounting Bracket .....	5-4
Packing an IFU for Shipment .....	5-5
<b>Appendix A — IFU Test Results .....</b>	<b>A-1</b>
Power Source Test .....	A-2
SONET OC-3 Fiber Optic Test .....	A-2
Far-End Test .....	A-2
Near-End Test .....	A-3
<b>Invisible Fiber™ Product Glossary .....</b>	<b>glossary-1</b>
<b>Index .....</b>	<b>index-1</b>

---



# List of Figures

<b>Figure 1-1.</b>	SONET OC-3 Fiber Optic Cable Configuration .....	1-4
<b>Figure 2-1.</b>	IFU Lifting Guideline .....	2-3
<b>Figure 2-2.</b>	IFU Power Cable Hookup .....	2-4
<b>Figure 2-3.</b>	Power Test Setup .....	2-4
<b>Figure 2-4.</b>	IFU Configuration Setup .....	2-6
<b>Figure 3-1.</b>	Example of IFU Bracket Attached to Wall .....	3-7
<b>Figure 3-2.</b>	Example of IFU Bracket Attached to Pole .....	3-8
<b>Figure 3-3.</b>	Typical Power Cable Wiring .....	3-10
<b>Figure 3-4.</b>	Typical IFU Power Termination Wiring Schematic .....	3-11
<b>Figure 3-5.</b>	Power Test Setup .....	3-12
<b>Figure 3-6.</b>	Demarcation Patch Panel .....	3-15
<b>Figure 3-7.</b>	Typical SONET OC-3 Demarcation Jumper Locations .....	3-17
<b>Figure 3-8.</b>	Typical SONET OC-3 Site Schematic .....	3-18
<b>Figure 3-9.</b>	SONET OC-3 Fiber Optic Continuity Test Setup .....	3-21
<b>Figure 3-10.</b>	Mounting the IFU .....	3-24
<b>Figure 3-11.</b>	IFU Cable Connections .....	3-25
<b>Figure 4-1.</b>	Coarse Alignment .....	4-3
<b>Figure 4-2.</b>	Alignment Test Setup .....	4-4
<b>Figure 5-1.</b>	IFU Cable Connections .....	5-3
<b>Figure 5-2.</b>	IFU Removal .....	5-5
<b>Figure 5-3.</b>	IFU Packaging Materials .....	5-6
<b>Figure 5-4.</b>	IFU Preparation .....	5-6

---

<b>Figure 5-5.</b>	Positioning the IFU .....	5-7
<b>Figure 5-6.</b>	Inserting the Radome Protector Sleeve .....	5-7
<b>Figure 5-7.</b>	Placing the Protective Cover .....	5-8
<b>Figure 5-8.</b>	Securing the Delivery Box .....	5-8





# List of Tables

<b>Table 2-1.</b>	Typical IFU Configuration Parts List .....	2-1
<b>Table 3-1.</b>	Site Installation Tools .....	3-2
<b>Table 3-2.</b>	Site Installation Parts (for two IFUs) .....	3-2
<b>Table 3-3.</b>	Typical Power Cable Wiring .....	3-10
<b>Table 3-4.</b>	Typical SONET OC-3 Demarcation Panel Input Connections .....	3-16
<b>Table 3-5.</b>	Typical SONET OC-3 Demarcation Panel Jumper Connections .....	3-17
<b>Table 3-6.</b>	SONET OC-3 Fiber Test Connections .....	3-21
<b>Table 4-1.</b>	Site Aligning Tools .....	4-2
<b>Table A-1.</b>	Power Supply Test Results .....	A-2
<b>Table A-2.</b>	SONET OC-3 Fiber Optic Test Results .....	A-2
<b>Table A-3.</b>	Far-End Test Results #1 .....	A-2
<b>Table A-4.</b>	Far-End Test Results #2 .....	A-3
<b>Table A-5.</b>	Near-End Test Results #1 .....	A-3
<b>Table A-6.</b>	Near-End Test Results #2 .....	A-3

---



# About This Book

The Triton Network Systems, Inc., 28 GHz Invisible Fiber™ unit (IFU) delivers high bandwidth, high-speed traffic through a wireless transport. IFUs are configured at the factory to work with Fast Ethernet or SONET applications. This book describes the SONET OC-3 application for the IFU.

## Purpose of This Book

This book describes how to:

### **Configure IFUs**

Perform preparatory (prior to installation) operations on an IFU, such as downloading attributes.

### **Install IFUs**

Install the brackets, mount the IFU, and run and connect cables.

### **Align IFUs**

Perform course and fine alignment on the IFUs.

### **Remove IFUs**

Servicing and removing an IFU.

The procedures include required verification tests and appropriate warning messages.

## Intended Audience

This book is written specifically for installation and aligning technicians and network engineers. The book assumes that the reader has a basic understanding of installing hardware.

---

## Format of This Book

This book contains:

Book Unit	Description
<i>Warnings and Safety Guidelines</i> on page xv	Provides a list of all warning, danger, and caution messages related to working with IFUs.
Chapter 1, <i>Installation Overview</i>	Describes a typical IFU installation, the types of cables used, and power requirements.
Chapter 2, <i>Staging Procedure</i>	Provides the procedures to perform before installing the IFU.
Chapter 3, <i>Installation Procedures</i>	Provides the component installation procedures.
Chapter 4, <i>Alignment Procedures</i>	Provides alignment and test procedures to ensure proper operation.
Chapter 5, <i>Removing an IFU</i>	Provides the procedure to remove and replace an IFU.
Appendix A, <i>IFU Test Results</i>	Provides test forms.
<i>Invisible Fiber™ Product Glossary</i>	Provides descriptions of product terminology.
<i>Index</i>	Provides an alphabetical list with the page location of information included in this book.

## Conventions Used in This Book

This book uses the following conventions:

- *Italic* - to indicate:
  - A book title
  - A heading or chapter title reference (for example, See *Conventions Used in This Book*)
  - Word emphasis (for example, *Do not* turn on the power....)
- A *Note*: label to identify an informational note. For example:

**NOTE:** Refer to the previous chapter for more information.

For warning and safety precaution conventions, see *Conventions* on page xv (English version) or *Conventions* on page xxi (French version).

---

## Contacting Triton Network Systems, Inc.

Direct any questions to your project liaison or:

Triton Network Systems, Inc.  
Technical Assistance Center (TAC)  
8529 SouthPark Circle  
Orlando, FL 32819  
Telephone - Domestic, Toll-free: 1-877-6TRITON (1-877-687-4866)  
Telephone - International: +1-407-903-2070  
E-Mail: [support@triton-network.com](mailto:support@triton-network.com)  
FAX: +1-407-903-0995

---



# Warnings and Safety Guidelines

## Conventions

The following list identifies the warning and caution graphic symbols used in this guide:



### **Risk of Personal Injury from Electrical Shock**

This symbol indicates a risk of personal injury due to an electrical shock.



### **Risk of Personal Injury from Fiber Optics**

This symbol indicates a risk of personal injury from fiber optic cable laser radiation.



### **Risk of Personal Injury from Radio Frequency Energy Exposure**

This symbol indicates a risk of personal injury due to radio frequency energy exposure.



### **Other Risks of Personal Injury**

This symbol indicates a risk of personal injury from a source other than electrical shock, laser radiation, or radio frequency energy exposure.



### **Risk of Service Interruption**

This symbol indicates a risk of service interruption or equipment damage.

---

## Risk of Personal Injury from Electrical Shock



**DANGER – HIGH CURRENT HAZARD:** Do not turn on power before reading the Triton Network Systems' product documentation. This device has a – 48 Vdc (5.0 amps operating peak per feed) direct current input.

**DANGER – HIGH CURRENT HAZARD:** Ensure that the – 48 Vdc power source is set to the OFF position before beginning the installation procedures for the Invisible Fiber™ unit.

**DANGER – HIGH VOLTAGE HAZARD:** Do not work on the system or connect or disconnect cables during periods of lightning activity, rainy weather, or both.

**WARNING:** Instructions for installing cables are intended for licensed contractors or building maintenance personnel.

## Risk of Personal Injury from Fiber Optics



**DANGER:** Invisible laser radiation. Avoid direct eye exposure to the end of a fiber, fiber cord, or fiber pigtail. The infrared light used in fiber optics systems is invisible, but can cause serious injury to the eye.

**WARNING:** Never touch exposed fiber with any part of your body. Fiber fragments can enter the skin and are difficult to detect and remove.

## Risk of Personal Injury from Radio Frequency Energy Exposure



**WARNING:** Beware! Radio transmitter is ON when the red light indicator on the back side of the Invisible Fiber™ unit is illuminated. Observe all radio frequency energy exposure and service interruption cautions.





**WARNING – RADIO FREQUENCY ENERGY:** To comply with FCC and Health Canada RF exposure requirements, a minimum separation distance of 40 feet in front of the Invisible Fiber™ unit is required between this antenna and all persons while the transmitter is ON. The radio transmitter is ON when the red light indicator on the back side of the radio enclosure is illuminated. Observe RF energy exposure safety limits, applicable rules, and service interruption cautions in the product manuals. Serious bodily injury may result.

## Other Risks of Personal Injury

**NOTE:** The following warnings and cautions are for risk of injury from sources other than electrical shock, fiber optics, or radio frequency energy exposure.



**WARNING:** This Invisible Fiber™ unit is designed to permit the connection of the earthed conductor from the DC source circuit to the earthing conductor at the Invisible Fiber™ unit. Do not switch or disconnect devices in the earthed circuit conductor between the DC source and point of connection of the earthing electrode conductor.

**WARNING:** Failure to follow operating instructions could result in death or serious injury.

**CAUTION:** Instructions for installing cables are intended for licensed contractors or building maintenance personnel.

**CAUTION – LIFTING HAZARD:** Two people are required to lift the Invisible Fiber™ unit. Grasp the Invisible Fiber™ unit underneath the lower edge and lift with both hands. To prevent injury, keep your back straight and lift with your legs, not your back. To prevent damage to the Invisible Fiber™ unit and components, never attempt to lift the radio by the attached cables.

**CAUTION:** Keep tools and parts away from walkways. When carrying large, heavy equipment (such as the Invisible Fiber™ unit), obstacles (such as hand tools, cables or components) may not be easily visible and can cause accidents.

---

## Risk of Service Interruption



**CAUTION:** Handle the Invisible Fiber™ unit with care to avoid equipment damage.

**CAUTION:** Ensure the outside optical fiber connectors are environmentally protected. Failure to do so may cause contamination of the fiber surfaces.

**CAUTION:** The Invisible Fiber™ unit contains no owner or user serviceable parts. Opening the radio unit or tampering with any of its seals voids all warranties.

**CAUTION:** Prior to installing an Invisible Fiber™ unit, the installation site must be surveyed to assess its appropriateness or adequacy, system requirements, path analysis, signal path, and power requirements.

**CAUTION:** Instructions for installing cables are intended for licensed contractors or building maintenance personnel.

**CAUTION:** *DO NOT* lift the Invisible Fiber™ unit by the radome (front) cover to avoid damaging the antenna.

**CAUTION:** Ensure the mounting bracket and Invisible Fiber™ unit are installed properly according to the instructions in the Triton Network Systems' product documentation.

**CAUTION:** Ensure that the – 48 Vdc power source is set to the OFF position before attaching power cables to the Invisible Fiber™ unit.

**CAUTION:** Do not block the front of the Invisible Fiber™ unit to avoid possible radio service interruption.

**CAUTION:** To reduce the risk of fiber optic cable damage, use the following bend radius guidelines for indoor/outdoor fiber optic cable:

- Long-term (installed): bend radius is equal to 10 times the diameter of the cable.
- Short-term (during installation): bend radius is equal to 20 times the diameter of the cable.

---

## Other Precautions

Failure to follow the installation procedure described in the Triton Network Systems' product documentation may result in damage to the Invisible Fiber™ unit and render the unit unusable. If you have any questions, contact your Triton Network Systems' project liaison or the Technical Assistance Center at:

Triton Network Systems, Inc.  
8529 SouthPark Circle  
Orlando, FL 32819

Telephone - Domestic, Toll-free: 1-877-6TRITON (1-877-687-4866)  
Telephone - International: +1-407-903-2070  
E-Mail: support@triton-network.com  
FAX: +1-407-903-0995

The Invisible Fiber™ unit must be installed in accordance with wall-mount or pole-mount specifications described in the Triton Network Systems' product documentation.

Observe all federal and local laws, regulations, electrical codes, building codes, fire codes, and licensing agreements.

### **RF Energy Exposure Safety Limits and Applicable Rules**

The radio is tested for RF radiation level exposures (per FCC OET-65 and FCC 47 CFR 1.1310 requirements) to transmit at below the FCC 47 CFR 1.1310 and Health Canada Safety Code radio frequency maximum permissible exposure limits (MPE) for controlled/occupational environment and below the FCC 47 CFR 1.1307 environmental radiation limit, when installed, operated, and maintained in strict accordance with the product operating and installation manuals and other materials accompanying the devices, at any time and under all operating conditions.

Ensure that appropriate warning signs are properly placed and posted at the equipment site or access entry.

**WARNING:** Changes or modifications to this unit not expressly approved by the party responsible for compliance could void the user's authority to operate the equipment.

---

The equipment has been tested and found to comply with the limits for a Class B digital device, pursuant to part 15 of the FCC rules. These limits are designed to provide reasonable protection against harmful interference in residential installations. This equipment generates, uses, and can radiate radio frequency energy, and if not installed and used in accordance with the instructions, may cause harmful interference to radio communications. However, there is no guarantee that interference will not occur in a particular installation. If this equipment does cause harmful interference to radio or television reception, which can be determined by turning the equipment off and on, the user is encouraged to try to correct the interference by performing

one or more of the following measures on the radio or television antenna that is affected by interference:

- Reorient or relocate the receiving antenna.
- Increase the separation between the equipment and the receiver.
- Connect the equipment to an outlet on a different circuit than the circuit the receiver is connected to.
- Consult the dealer or an experienced radio or TV technician for help.

This device complies with RSS-191 of Industry Canada. Operation is subject to the following two conditions:

- This device may not cause interference.
- This device must accept any interference, including interference that may cause undesired operation of the device.

This Class B digital apparatus complies with Canadian ICES-003.



# Avertissements et consignes de sécurité

## Conventions

La liste suivante explique les symboles d'avertissement et de mise en garde utilisés dans ce guide :



### Risque de lésions corporelles provoquées par la décharge électrique

Ce symbole indique un risque de lésions corporelles provoquées par la décharge électrique.



### Risque de lésions corporelles provoquées par les câbles à fibres optiques

Ce symbole indique un risque de lésions corporelles provoquées par les câbles à fibres optiques.



### Risque de lésions corporelles provoquées par l'exposition de l'énergie radiofréquences

Ce symbole indique un risque de lésions corporelles provoquées par l'exposition de l'énergie radiofréquences.



### Autres risques de lésions corporelles

Ce symbole indique d'un risque de lésions corporelles (à part celles provoquées par la décharge électrique, par la radiation du laser, ou par l'exposition de l'énergie radiofréquences).



### Risque d'interruption de service

Ce symbole indique un risque d'interruption de service ou de dommage aux équipements.

---

## Risque de lésions corporelles provoquées par la décharge électrique



**DANGER – L’HASARD DU COURANT ÉLEVÉ :** Ne pas mettre la tension avant de lire la documentation du produit fournie par la société Triton Network Systems. Cet appareil a une alimentation directe de – 48 V CC (courant de pointe de 5.0 ampères par ligne d’alimentation).

**DANGER – L’HASARD DU COURANT ÉLEVÉ :** S’assurer que le bloc d’alimentation – 48 V CC est en position HORS TENSION avant d’aborder les procédures pour l’installation de l’unité Invisible Fiber<sup>MD</sup>.

**DANGER – L’HASARD DU TENSION ÉLEVÉ :** Ne pas travailler sur le système ni brancher ni débrancher les câbles durant l’activité de la foudre, par de temps pluvieux, ou tous le deux.

**AVERTISSEMENT :** Les instructions pour l’installation des câbles sont destinées exclusivement aux entrepreneurs agréés et aux préposés à l’entretien de l’immeuble.

## Risque de lésions corporelles provoquées par les câbles à fibres optiques



**DANGER :** Rayonnement laser invisible. Éviter l’exposition directe des yeux à l’extrémité d’une fibre, d’un cordon à fibres ou d’une fibre amorce. La lumière infrarouge utilisée dans les systèmes à fibres optiques est invisible, mais peut provoquer des lésions graves aux yeux.

**AVERTISSEMENT :** Ne jamais laisser une fibre nue entrer en contact avec une partie quelconque du corps. Des fragments de fibre peuvent entrer dans la peau, et sont difficiles à déceler et à enlever.

---

## Risque de lésions corporelles provoquées par l'exposition de l'énergie radiofréquences



**MISE EN GARDE :** Attention ! Le poste émetteur est EN MARCHÉ lorsque le témoin rouge sur le dos de l'unité Invisible Fiber<sup>MD</sup> est allumé. Respecter toutes les mises en garde concernant l'exposition aux radiofréquences et l'interruption de service.

**AVERTISSEMENT : ENERGIE AUX FRÉQUENCES RADIOÉLECTRIQUES :** afin d'être conforme aux exigences concernant l'exposition RF du FCC et du Ministère de la Santé Canadien, une distance de séparation minimale de 40 pieds devant l'appareil Invisible Fiber<sup>TM</sup> est nécessaire entre cette antenne et toute personne présente lorsque l'émetteur est allumé (ON). L'émetteur radio est allumé (ON) lorsque le voyant lumineux rouge situé au dos du boîtier radioélectrique est illuminé. Veuillez observer les limites de sécurité concernant l'exposition RF, les règles applicables et les avertissements d'interruption de service indiqués dans les manuels d'utilisation fournis avec le produit. Le non respect de ces mesures de sécurité risquerait d'entraîner des blessures corporelles grave.

## Autres risques des lésions corporelles

Les mises en garde suivantes concernent les risques de lésions corporelles attribuables à des causes autres que la décharge électrique, la radiation du laser, ou l'exposition de l'énergie radiofréquences.



**AVERTISSEMENT :** Cette unité Invisible Fiber<sup>MD</sup> permet la connexion entre le conducteur de mise à la terre du circuit d'alimentation CC et le conducteur de mise à la terre de l'unité Invisible Fiber<sup>MD</sup>. Ne pas changer ni débrancher les dispositifs qui se trouvent dans le conducteur du circuit mis à la terre entre la source de l'énergie CC et le point de connexion au conducteur de l'électrode de prise de terre.

**AVERTISSEMENT :** Ne pas suivre les instructions d'utilisation peut causer de sérieuses blessures et même la mort.

**MISE EN GARDE :** Les instructions pour l'installation des câbles sont destinées exclusivement aux entrepreneurs agréés et aux préposés à l'entretien de l'immeuble.



**MISE EN GARDE – DANGER DE LEVAGE :** Il faut deux personnes pour soulever l'unité Invisible Fiber<sup>MD</sup>. Saisir l'unité Invisible Fiber<sup>MD</sup> au-dessous du rebord inférieur, puis soulever l'unité avec les deux mains. Pour éviter les lésions corporelles, garder le dos en position verticale et soulever l'unité en utilisant les jambes et non pas les reins. Pour éviter l'endommagement de l'unité Invisible Fiber<sup>MD</sup> et de ses composants, ne jamais essayer de soulever la radio en tirant sur les câbles qui y sont attachés.

**MISE EN GARDE :** Garder les outils et les pièces loin des allées. Lorsqu'on transporte des équipements lourds et à grandes dimensions (tels que l'unité Invisible Fiber<sup>MD</sup>), les obstacles (tels que les outils à main, les câbles ou les composants) sont parfois difficiles à voir et peuvent causer des accidents.

## Risque d'interruption de service



**MISE EN GARDE :** Manipuler l'unité Invisible Fiber<sup>MD</sup> avec soin pour éviter des dommages aux équipements.

**MISE EN GARDE :** S'assurer que les raccords extérieurs fibre optique sont protégés contre l'environnement. L'absence d'une telle protection peut entraîner la contamination des surfaces des fibres.

**MISE EN GARDE :** L'unité Invisible Fiber<sup>MD</sup> contient pas de parts utilisés par le propriétaire ou l'utilisateur. Ouverture de l'unité de la radio ou toucher aux scelles rend toute garantie nulle et non avenue.

**MISE EN GARDE :** Avant d'installer une unité Invisible Fiber<sup>MD</sup>, il faut vérifier que les lieux de l'installation sont convenables et adéquats, déterminer les besoins du système, analyser les trajets, préciser le parcours du signal et déterminer les exigences en matière d'énergie.

**MISE EN GARDE :** Les instructions pour l'installation des câbles sont destinées exclusivement aux entrepreneurs agréés et aux préposés à l'entretien de l'immeuble.

**MISE EN GARDE :** *NE PAS* soulever l'unité Invisible Fiber<sup>MD</sup> par le couvercle du radôme (couvercle avant), afin d'éviter l'endommagement de l'antenne.

**MISE EN GARDE :** S'assurer que le support de montage et l'unité Invisible Fiber<sup>MD</sup> sont installés convenablement, selon les instructions figurant dans la documentation du produit fournie par la société Triton Network Systems.





**MISE EN GARDE :** S'assurer que le bloc d'alimentation – 48 V CC est en position HORS TENSION avant d'attacher les câbles d'alimentation à l'unité Invisible Fiber<sup>MD</sup>.

**MISE EN GARDE :** Ne pas bloquer le devant de l'unité Invisible Fiber<sup>MD</sup>, pour éviter toute interruption éventuelle du service de transmission radio.

**MISE EN GARDE :** Pour réduire le risque de dommage aux câbles à fibres optiques, suivre les consignes suivantes en matière de rayon de courbure des câbles à fibres optiques extérieurs ou intérieurs :

- Courbure à long terme (installée). Le rayon de courbure ne doit pas dépasser 10 fois le diamètre du câble.
- Courbure à court terme (pendant l'installation). Le rayon de courbure ne doit pas dépasser 20 fois le diamètre du câble.

## Autres mises en garde

L'inobservation de la procédure d'installation décrite dans la documentation du produit fournie par la société Triton Network Systems peut endommager l'unité Invisible Fiber<sup>MD</sup> et la rendre inutilisable. Si vous avez des questions à poser, veuillez communiquer avec votre agent de liaison des projets chez Triton Network Systems, ou bien joindre notre Centre d'assistance technique à l'adresse suivante :

Triton Network Systems, Inc.  
8529 SouthPark Circle  
Orlando, FL 32819  
Téléphone - Aux États-Unis, sans frais : 1-877-6TRITON (1-877-687-4866)  
Téléphone - Dans d'autres pays : +1-407-903-2070  
Internet : support@triton-network.com  
Télécopieur : +1-407-903-0995

Il faut installer l'unité Invisible Fiber<sup>MD</sup> selon la spécification pour le montage mural ou sur poteau, telle que précisée dans la documentation du produit fournie par la société Triton Network Systems.

Il faut respecter l'ensemble des lois, règlements, codes d'électricité, codes du bâtiment et codes des incendies du gouvernement fédéral et des municipalités ainsi que tous les contrats de licence.

---

### **Limites de sécurité à propos de l'énergie RF et règles applicables**

La radio est testée pour un niveau d'exposition de radiation RF (selon les exigences FCC OET-65 et FCC 47 CFR 1.1310) afin d'émettre en dessous des limites des doses maximales admissibles en matière de fréquence radioélectrique du FCC 47 CFR 1.1310 et du Ministère de la Santé Canadien (MPE) en milieu contrôlé et professionnel et en dessous des limites de radiation pour la protection de l'environnement FCC 47 CFR 1.1307 lorsque l'appareil est installé, utilisé et entretenu en accord strict avec les manuels d'entretien et de fonctionnement ainsi que tout autre manuel livré avec les appareils, à tout moment et dans toutes les conditions de fonctionnement.

Assurez que le signals d'avertissement appropriés soivant placés appropriatement et affichés dans la location d'équipement ou l'accès d'y entrer.

Cet appareil est conforme au RSS-191 de Industrie Canada. L'utilisation dépend des deux conditions suivantes:

- Cet appareil ne devrait pas causer d'interférence.
- Cet appareil doit accepter toute interférence, y compris une interférence pouvant causer une opération indésirable de l'appareil.

Cet appareil numerique de la classe B est conforme avec la norme NMB-003 du Canada.



# Installation Overview

This chapter provides an overview of the installation procedure for the Invisible Fiber™ unit (IFU). In addition, this chapter describes the following:

- IFU Link Manager
- Power source
- Cables
- System grounding and surge suppression

## Installation Overview

IFUs are loaded with default system attributes at the factory. At the customer's designated staging area, the customer-specific attributes identified in the site database are downloaded to the IFU, which is then ready for installation. At the installation site, the IFU is installed on a mounting bracket, aligned, and commissioned. When all installation tests are complete and expected results are achieved on all IFU sites, the network is ready for customer acceptance.

## Site Engineering Folder

Before installing the IFU, the site must be prepared with the appropriate cables, demarcation box, and any equipment as detailed in the site engineering folder. (Refer to the *Invisible Fiber™ SONET OC-3 Site Evaluation Guide for 28 GHz Applications* for details about the contents of the site engineering folder.)

The site engineering folder is referenced throughout this document. Photos and diagrams of the site are included in the folder.

## IFU Link Manager

The IFU Link Manager is a local element management software application that helps you configure and commission the IFU. You use this application to complete the following procedures:

- IFU configuration
- Antenna alignment

## Power Source

The IFUs require a – 48 Vdc power source. The specifications of the power source are defined in the site engineering folder.

## Cabling

IFU installations require the following two types of cables:

### **Power**

The power cable connects the IFU to the – 48 Vdc power source.

### **Fiber Optic**

The fiber optic cable connects the IFU to the site equipment cabinet.

## Power Cable

The power cable is outdoor/indoor rated. The power cable contains four 12-AWG conductors.

## Fiber Optic Cable

For SONET networks, the IFU requires a multi-mode and single-mode fiber optic cables (see Figure 1-1).

## System Grounding and Surge Protection

The IFU grounding system has two conceptually distinct, but electrically interconnected functional subsystems, for connection to “earth ground.” The two functional subsystems are:

- Earth ground (complies with the National Electrical Code (NEC) for equipment grounding systems).
- Surge protection.

### Earth Ground

The IFU has an external electrical interconnection point for connecting the IFU ground subsystems to earth ground.

### Surge Protection

The sole purpose of surge protection is to transport lightning-related currents to the earth ground. During site installation, surge suppression devices are installed in line with the power and alarm conductors to assist in protecting equipment.

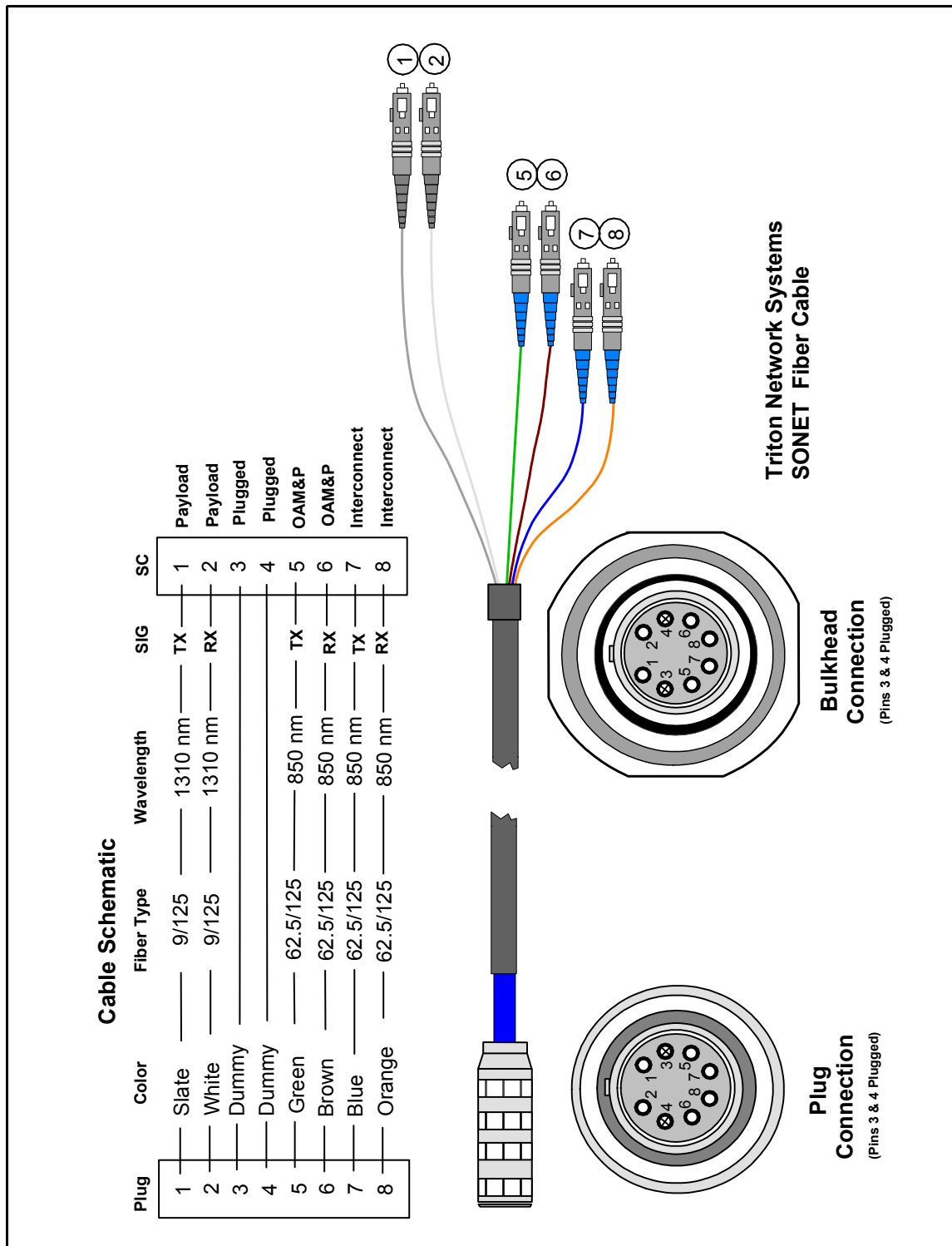

Figure 1-1. SONET OC-3 Fiber Optic Cable Configuration



# Staging Procedure

This chapter describes the IFU configuration procedure to be performed at the designated staging area.

## Configuring IFUs

IFUs are configured by using the IFU Link Manager application to load the site-specific attributes from the attributes table in the site engineering folder.

Table 2-1 identifies the parts needed for configuring a typical IFU site. Figure 2-1 refers to the IFU and the IFU lifting guidelines.

**Table 2-1.** Typical IFU Configuration Parts List

Item No.	Description	Qty.
1	IFU	1
2	BNC-banana plug adapter	1
3	IFU Link Manager test cable	1
4	Laptop computer with IFU Link Manager installed	1
5	Power source (– 48 Vdc)	1
6	IFU power cable	1
7	Site engineering folder	1
8	Digital multimeter	1

► **To configure each IFU, complete the following steps:**

- 1 Remove the IFU from the shipping carton and place it upright on a table with the antenna radome cover facing away from you and the connectors facing you. Verify that the part number on the IFU label matches the attributes table in the site engineering folder.

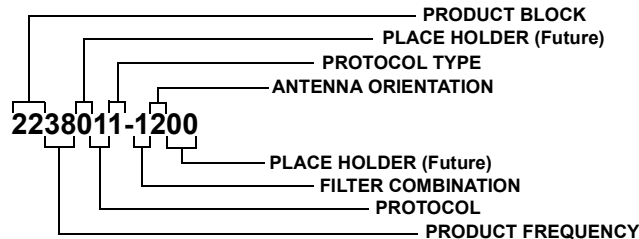

22380PT-FA00 is a sample part number, where the letters are variables defined as follows:

P = Protocol (1=SONET, 2=Ethernet)

T = Protocol type (1=OC-3, 2=OC-12, 1=Fast, 2=Gigabit)

F = Filter combination for transmit/receive (1=1/3, 2=2/4  
3=3/1, 4=4/2)

A = Antenna orientation (1=Vertical, 2=Horizontal)

---

**CAUTION – LIFTING HAZARD:** Two people are required to lift the Invisible Fiber™ unit. Grasp the Invisible Fiber™ unit underneath the lower edge and lift with both hands. To prevent injury, keep your back straight and lift with your legs, not your back. To prevent damage to the Invisible Fiber™ unit and components, never attempt to lift the radio by the attached cables.



**MISE EN GARDE – DANGER DE LEVAGE :** Il faut deux personnes pour soulever l'unité Invisible Fiber<sup>MD</sup>. Saisir l'unité Invisible Fiber<sup>MD</sup> au-dessous du rebord inférieur, puis soulever l'unité avec les deux mains. Pour éviter les lésions corporelles, garder le dos en position verticale et soulever l'unité en utilisant les jambes et non pas les reins. Pour éviter l'endommagement de l'unité Invisible Fiber<sup>MD</sup> et de ses composants, ne jamais essayer de soulever la radio en tirant sur les câbles qui y sont attachés.

---





**CAUTION:** *DO NOT* lift the Invisible Fiber™ unit by the radome (front) cover to avoid damaging the antenna.

**MISE EN GARDE :** *NE PAS* soulever l'unité Invisible Fiber<sup>MD</sup> par le couvercle du radôme (couvercle avant), afin d'éviter l'endommagement de l'antenne.

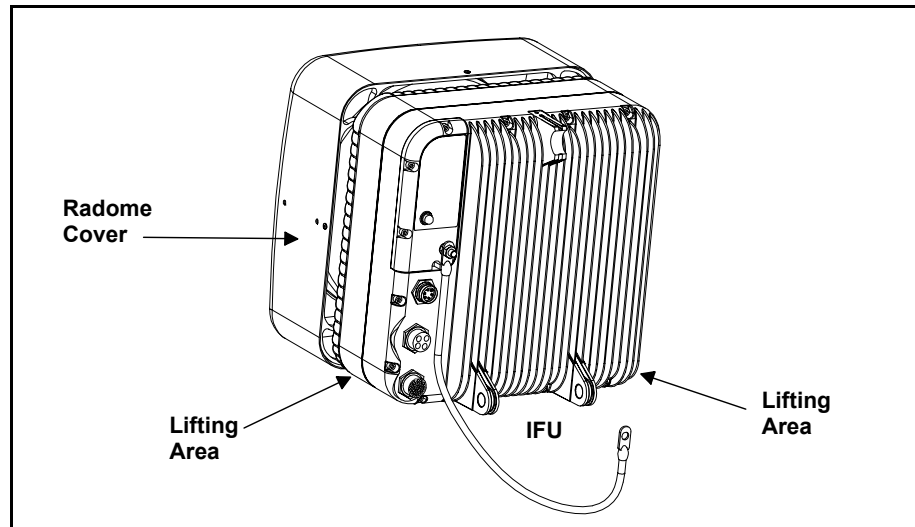

Figure 2-1. IFU Lifting Guideline

**DANGER – HIGH VOLTAGE HAZARD:** Do not work on the system or connect or disconnect cables during periods of lightning activity, rainy weather, or both.



**DANGER – L'HASARD DU TENSION ÉLEVÉ :** Ne pas travailler sur le système ni brancher ni débrancher les câbles durant l'activité de la foudre, par de temps pluvieux, ou tous le deux.

**DANGER – HIGH CURRENT HAZARD:** Ensure that the – 48 Vdc power source is set to the OFF position before beginning the installation procedures for the Invisible Fiber™ unit.



**DANGER – L'HASARD DU COURANT ÉLEVÉ :** S'assurer que le bloc d'alimentation – 48 V CC est en position HORS TENSION avant d'aborder les procédures pour l'installation de l'unité Invisible Fiber<sup>MD</sup>.

- 2 Connect the IFU power cable to the – 48 Vdc power source as shown in Figure 2-2.

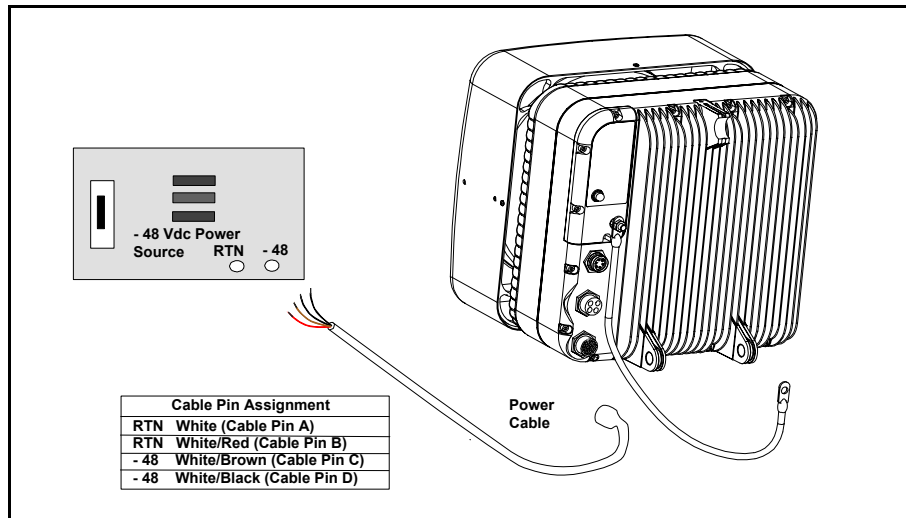

Figure 2-2. IFU Power Cable Hookup

- 3 Set the – 48 Vdc power source to ON.
- 4 Set the multimeter to DC voltage.
- 5 Connect a black test lead from the **negative** input of the multimeter to pin **B** on the IFU power cable (see Figure 2-3).

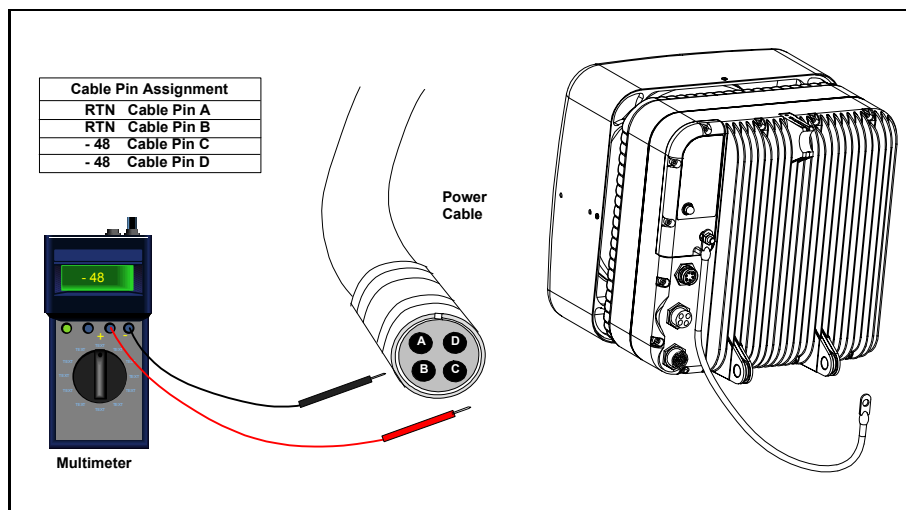

Figure 2-3. Power Test Setup

- 6 Connect a red test lead from the **positive** input of the multimeter to pin **D** on the IFU power cable.
- 7 Read the measurement on the multimeter. Passing criteria is – 46 Vdc to – 56 Vdc.
- 8 Connect a black test lead from the **negative** input of the multimeter to pin **A** on the IFU power cable.
- 9 Connect a red test lead from the **positive** input of the multimeter to pin **C** on the IFU power cable.
- 10 Read the measurement on the multimeter. Passing criteria is – 46 Vdc to – 56 Vdc.
- 11 Set the – 48 Vdc power source to OFF.



---

**DANGER – HIGH CURRENT HAZARD:** Do not turn on power before reading the Triton Network Systems' product documentation. This device has a – 48 Vdc (5 amps operating peak per feed) direct current input.

**DANGER – L'HASARD DU COURANT ÉLEVÉ :** Ne pas mettre la tension avant de lire la documentation du produit fournie par la société Triton Network Systems. Cet appareil a une alimentation directe de – 48 V CC (courant de pointe de 5 ampères par ligne d'alimentation).

---



---

**DANGER – HIGH CURRENT HAZARD:** Ensure that the – 48 Vdc power source is set to the OFF position before beginning the installation procedures for the Invisible Fiber™ Unit.

**DANGER – L'HASARD DU COURANT ÉLEVÉ :** S'assurer que le bloc d'alimentation – 48 V CC est en position HORS TENSION avant d'aborder les procédures pour l'installation de l'unité Invisible Fiber<sup>MD</sup>.

---

- 12 Connect the – 48 Vdc power cable to the power connector on the IFU as illustrated in Figure 2-4.

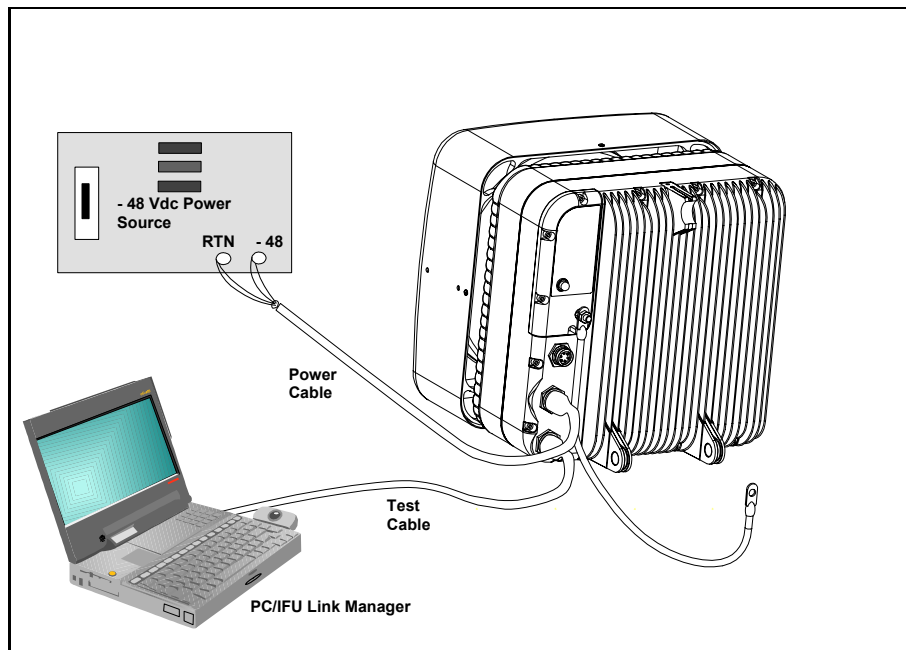

**Figure 2-4.** IFU Configuration Setup

**13** Set the – 48 Vdc power source to ON.

---

**WARNING:** Beware! Radio transmitter is ON when the red light indicator on the back side of the Invisible Fiber™ unit is illuminated. Observe all radio frequency energy exposure and service interruption cautions.



**MISE EN GARDE :** Attention ! Le poste émetteur est EN MARCHE lorsque le témoin rouge sur le dos de l'unité Invisible Fiber<sup>MD</sup> est allumé. Respecter toutes les mises en garde concernant l'exposition aux radiofréquences et l'interruption de service.

---



**WARNING – Radio Frequency energy:** To comply with FCC and Health Canada RF exposure requirements, a minimum separation distance of 40 feet in front of the Invisible Fiber™ unit is required between this antenna and all persons while the transmitter is ON. The radio transmitter is ON when the red light indicator on the back side of the radio enclosure is illuminated. Observe RF energy exposure safety limits, applicable rules, and service interruption cautions in the product manuals. Serious bodily injury may result.

**AVERTISSEMENT : ENERGIE AUX FRÉQUENCES RADIOÉLECTRIQUES :** afin d'être conforme aux exigences concernant l'exposition RF du FCC et du Ministère de la Santé Canadien, une distance de séparation minimale de 40 pieds devant l'appareil Invisible Fiber™ est nécessaire entre cette antenne et toute personne présente lorsque l'émetteur est allumé (ON). L'émetteur radio est allumé (ON) lorsque le voyant lumineux rouge situé au dos du boîtier radioélectrique est illuminé. Veuillez observer les limites de sécurité concernant l'exposition RF, les règles applicables et les avertissements d'interruption de service indiqués dans les manuels d'utilisation fournis avec le produit. Le non respect de ces mesures de sécurité risquerait d'entraîner des blessures corporelles grave.

**14** Connect a laptop computer to the IFU as shown in Figure 2-4.



**WARNING:** Failure to follow operating instructions could result in death or serious injury.

**AVERTISSEMENT :** Ne pas suivre les instructions d'utilisation peut causer de sérieuses blessures et même la mort.

**15** Enter the site attributes from the site database into the IFU Link Manager program.

**NOTE:** Refer to IFU Link Manager help screens to enter the required site database attributes.

**16** Power down the IFU and remove the cables.

**NOTE:** If the staging site and the installation site are the same place, continue with Chapter 3, *Installation Procedures*.

- 17** Confirm that the correct installation address is on the packing box and the packing box label matches the IFU data plate, which is located on the back of the IFU.
- 18** Use the original packing material to ship the IFU to the installation site. Should the packing material not be available, contact Triton Network Systems (see *Contacting Triton Network Systems, Inc.* on page xiii).
- 19** Use the repacking information located in *Packing an IFU for Shipment* on page 5-5 for instructions on how to repackage the IFU for shipment.



# Installation Procedures

This chapter provides the procedures for installing IFU components and IFUs.

---

**NOTE:** Observe all federal and local laws, regulations, electrical codes, building codes, fire codes, and licensing agreements.

Il faut respecter l'ensemble des lois, règlements, codes du bâtiment et codes des incendies du gouvernement fédéral et des municipalités ainsi que tous les contrats de licence.

---

---

**NOTE:** Failure to follow the installation procedure described in the Triton Network Systems' product documentation may result in damage to the Invisible Fiber™ unit and render the unit unusable. Read through the entire installation procedure before beginning installation.

L'inobservation de la procédure d'installation décrite dans la documentation du produit fournie par la société Triton Network Systems peut endommager l'unité Invisible Fiber<sup>MD</sup> et la rendre inutilisable.

---

This chapter includes the following topics:

- Setup
- Installing IFU components
- Determining IFU mounting requirements
- Installing an IFU

The instructions in this chapter describe the procedure for installing two IFUs. Use the same process to install one IFU or many IFUs; the wiring conventions are the same.

# Setup

## Before Starting

Before starting the procedures in this chapter, verify that all parts have been received by checking the received items against the equipment and parts lists in the site engineering folder.

## Preparing for Installation

Table 3-1 identifies the special tools required for installation and Table 3-2 identifies the parts required.

**Table 3-1.** Site Installation Tools

Item No.	Description	Qty.
1	Digital multimeter	1
2	Fiber cleaning kit (solution & air)	1
3	Fiber scope	1
4	Optical light source	1
5	Optical power meter	1
6	FSI test cable	1
7	Site engineering folder	1
8	Right-angled snap ring pliers (for external snap ring)	1

**Table 3-2.** Site Installation Parts (for two IFUs)

Item No.	Description	Qty.
1	IFU	2
2	IFU mounting bracket with snap ring kit	2
3	IFU power cable	2
4	Fiber optic cable	2
5	Tie-wraps, UV-rated	A/R



## Installing IFU Components

This section describes how to perform the following:

- Determine IFU mounting requirements
- Mount the IFU bracket
- Install the power cables
- Install the alarm cables
- Install the fiber optic cables

## Determining IFU Mounting Requirements



---

**WARNING:** Beware! Radio transmitter is ON when the red light indicator on the back side of the Invisible Fiber™ unit is illuminated. Observe all radio frequency energy exposure and service interruption cautions.

**MISE EN GARDE :** Attention ! Le poste émetteur est EN MARCHE lorsque le témoin rouge sur le dos de l'unité Invisible Fiber<sup>MD</sup> est allumé. Respecter toutes les mises en garde concernant l'exposition aux radiofréquences et l'interruption de service.

---



---

**WARNING – Radio Frequency energy:** To comply with FCC and Health Canada RF exposure requirements, a minimum separation distance of 40 feet in front of the Invisible Fiber™ unit is required between this antenna and all persons while the transmitter is ON. The radio transmitter is ON when the red light indicator on the back side of the radio enclosure is illuminated. Observe RF energy exposure safety limits, applicable rules, and service interruption cautions in the product manuals. Serious bodily injury may result.

**AVERTISSEMENT : ENERGIE AUX FRÉQUENCES RADIOÉLECTRIQUES :** afin d'être conforme aux exigences concernant l'exposition RF du FCC et du Ministère de la Santé Canadien, une distance de séparation minimale de 40 pieds devant l'appareil Invisible Fiber™ est nécessaire entre cette antenne et toute personne présente lorsque l'émetteur est allumé (ON). L'émetteur radio est allumé (ON) lorsque le voyant lumineux rouge situé au dos du boîtier radioélectrique est illuminé. Veuillez observer les limites de sécurité concernant l'exposition RF, les règles applicables et les avertissements d'interruption de service indiqués dans les manuels d'utilisation fournis avec le produit. Le non respect de ces mesures de sécurité risquerait d'entraîner des blessures corporelles grave.

---

The mounting locations must allow the IFU to obtain clear line of sight to the far-end IFU.

► **To determine the mounting location and method:**

- 1 With the building manager, define the mounting location and method (wall mount or pole mount).

**NOTE:** The preferred mounting location is on a wall because it is generally structurally sound. The IFU's streamlined exterior is designed to complement building aesthetics.

- 2 After defining the mounting location for the IFU, re-verify the line of sight.
- 3 For wall- and pole-mount criterians, the bottom of the IFU should be at least eight feet above the roof.

### **Wall-Mount Criteria**

Wall mounting can be on a parapet wall, screen wall, or penthouse wall that meets the following criteria:

- The wall must be structurally capable of supporting at least 80 pounds, plus the wind loading as required by the local building codes.
- The wall must allow through-hole bolt mounting.
- The space for the IFU, its mounting bracket, and the alignment area must be at least 65 inches by 65 inches by 30 inches (W x H x D).

### **Pole-Mount Criteria**

The pole can be attached to the wall or free-standing.

If the pole is attached to a wall, the pole must be structurally capable of supporting at least 80 pounds, plus the wind loading as required by the local building codes.

For free-standing poles, calculate the amount of ballast based on the building's wind loading requirements. Consult the pole manufacturer for the required ballast weight to secure the free-standing pole.

**NOTE:** The total weight of the pole with the IFU can be upwards of 550 pounds. Consult the pole manufacturer for the required weight for the ballasts to secure the free-standing pole roof space required.

## **RF Energy Exposure Safety Limits and Applicable Rules**

The radio is tested for RF radiation level exposures (per FCC OET-65 and FCC 47 CFR 1.1310 requirements) to transmit at below the FCC 47 CFR 1.1310 and Health Canada Safety Code radio frequency maximum permissible exposure limits (MPE) for controlled/occupational environment and below the FCC 47 CFR 1.1307 environmental radiation limit, when installed, operated, and maintained in strict accordance with the product operating and installation manuals and other materials accompanying the devices, at any time and under all operating conditions.

Ensure that appropriate warning signs are properly placed and posted at the equipment site or access entry.

For a complete list of warnings and safety guidelines, refer to *Warnings and Safety Guidelines* on page xv.

# Mounting the IFU Bracket

Using approved engineering methods, mount the IFU bracket in the location specified in the site engineering folder (see Figure 3-1 for typical wall mounting and Figure 3-2 for typical pole mounting).

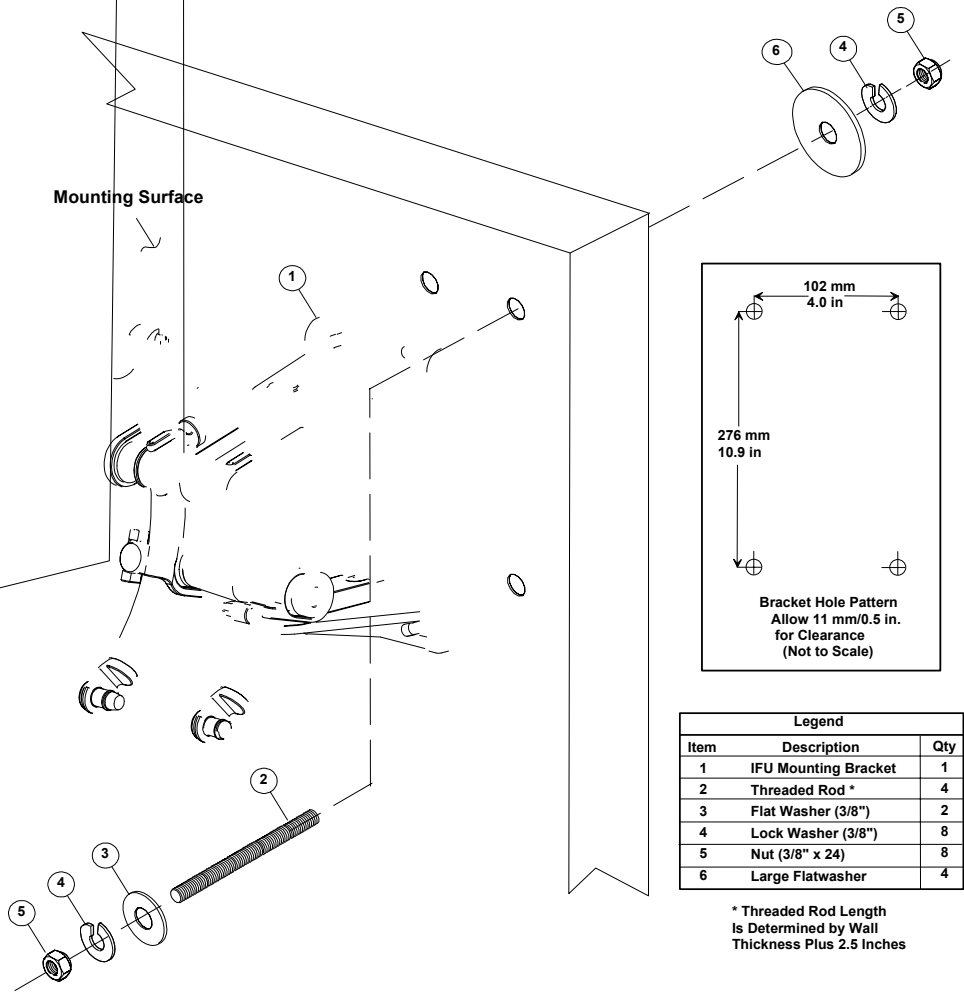

**Figure 3-1.** Example of IFU Bracket Attached to Wall

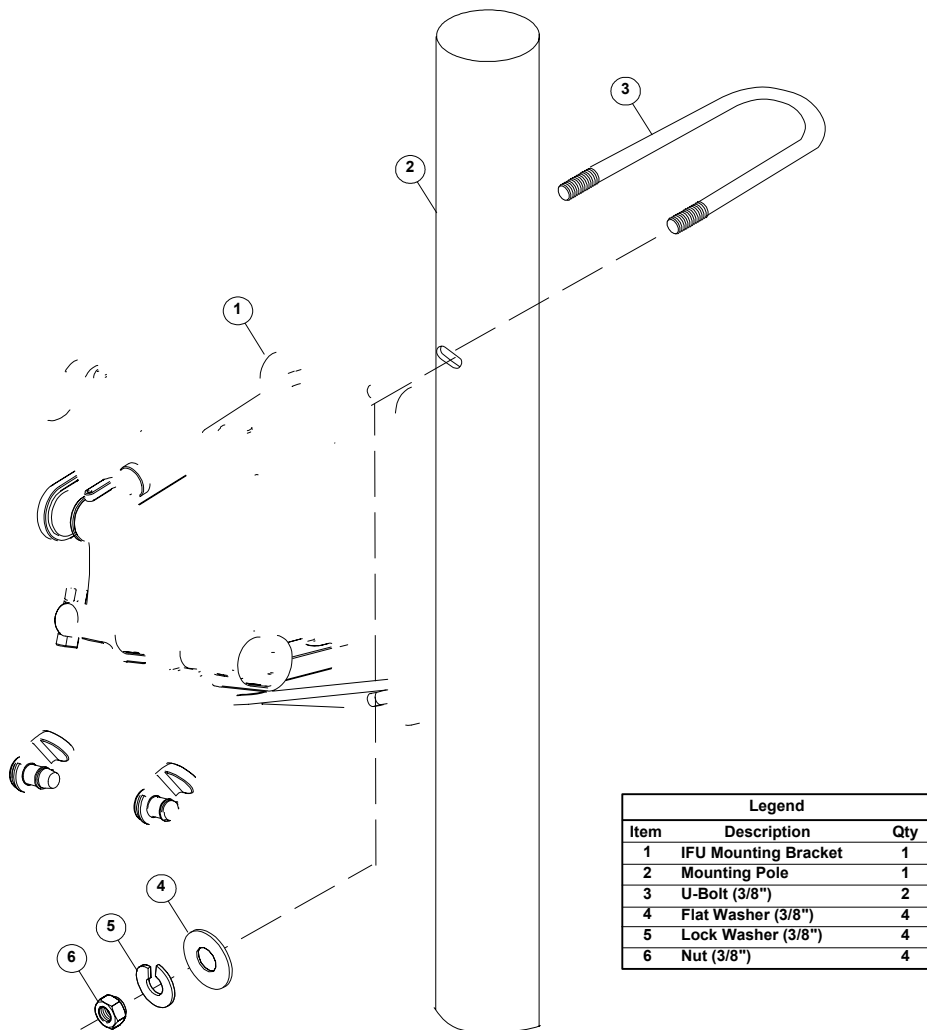

**Figure 3-2.** Example of IFU Bracket Attached to Pole

**NOTE:** Refer to the site engineering folder for the correct location and then mount the bracket to the building or pole, using bolts as indicated.

**NOTE:** Ensure the mounting bracket is mechanically stable, plumb, and level.

## Installing Power Cables

There are two cable routes as follows:

- The IFU Alpha power cable runs from the IFU mounting location to the surge suppression assembly.
- The IFU Beta power cable runs from the IFU mounting location to the surge suppression assembly.

### ► To install the IFU power cables:



**DANGER – HIGH VOLTAGE HAZARD:** Do not work on the system or connect or disconnect cables during periods of lightning activity, rainy weather, or both.

**DANGER – L'HASARD DU TENSION ÉLEVÉ :** Ne pas travailler sur le système ni brancher ni débrancher les câbles durant l'activité de la foudre, par de temps pluvieux, ou tous le deux.



**CAUTION:** Instructions for installing cables are intended for licensed contractors or building maintenance personnel.

**MISE EN GARDE :** Les instructions pour l'installation des câbles sont destinées exclusivement aux entrepreneurs agréés et aux préposés à l'entretien de l'immeuble.

- 1 Route the IFU power cables to a surge suppression assembly according to the site drawing.

**NOTE:** Allow an extra three-foot service loop at the IFU and twelve inches at each surge suppressor. Use large radius bends to avoid kinking the cables during the cable routing.

**NOTE:** Connect the cable shields to the suppressor mounting panel. Trim the shield back to the cable breakout and keep the shield as short as possible.

- 2 Trim each cable to the appropriate length.
- 3 Strip each cable wire to 3/8 inch and tin.
- 4 Attach the IFU power cables to the surge suppressors as shown on Figure 3-3, Table 3-3, and Figure 3-4.

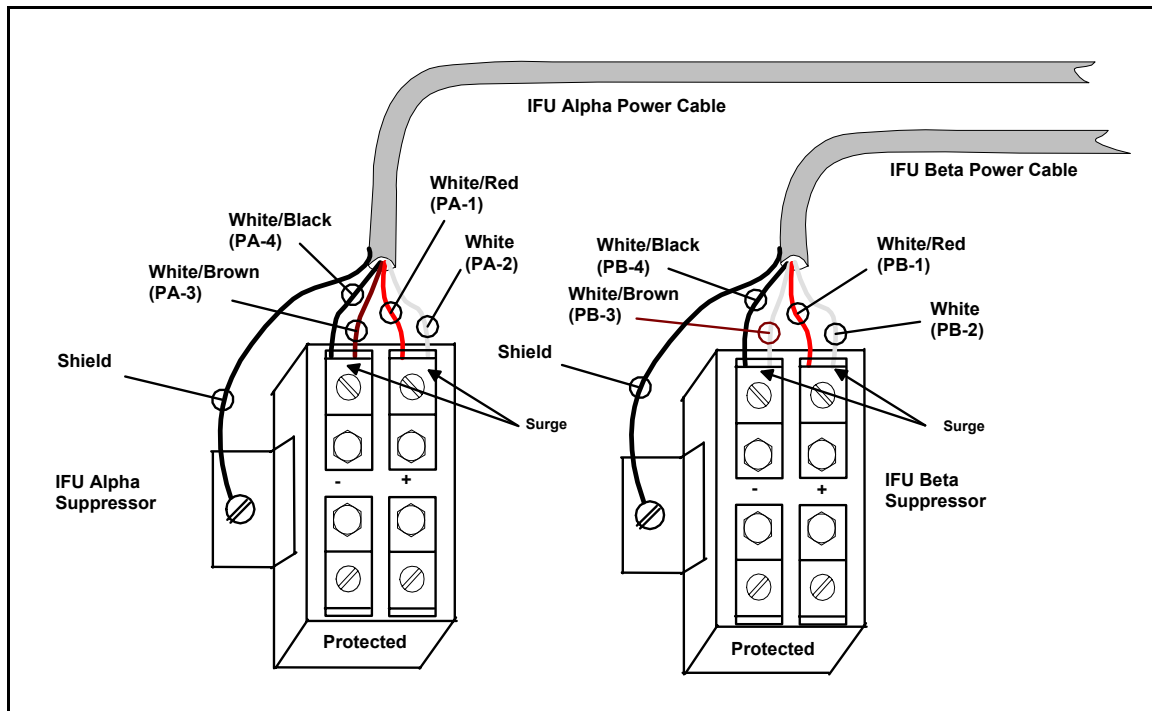

Figure 3-3. Typical Power Cable Wiring

Table 3-3. Typical Power Cable Wiring

IFU Alpha Surge Input	Wire Color/ Number	IFU Beta Surge Input	Wire Color/ Number
RTN (+)	White (PA-2), White/Red (PA-1)	RTN (+)	White (PB-2), White/Red (PB-1)
- 48 (-)	White/Black (PA-4), White/Brown (PA-3)	- 48 (-)	White/Black (PB-4), White/Brown (PB-3)



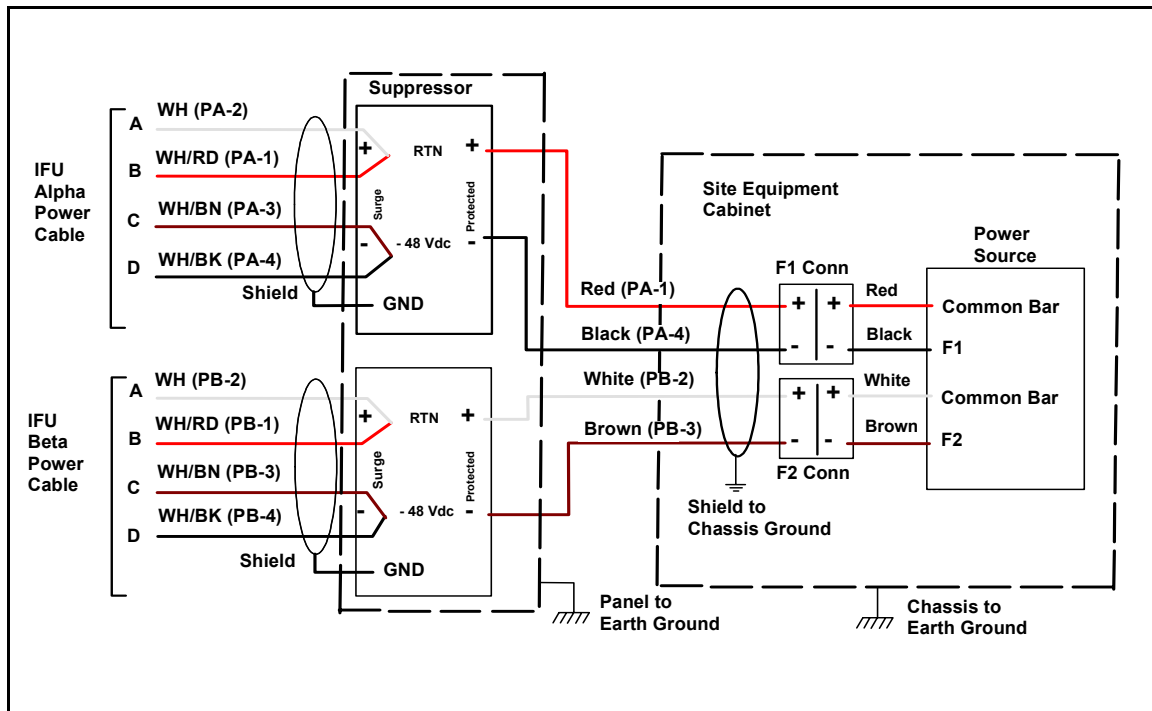

Figure 3-4. Typical IFU Power Termination Wiring Schematic

## IFU Power Cable Test

To ensure proper wiring, perform the input power test on both IFU power cables prior to connecting to the IFU. This test ensures that the input power to the IFU is between  $-46\text{ Vdc}$  and  $-56\text{ Vdc}$ .

### ► To test the power cable:

**DANGER – HIGH VOLTAGE HAZARD:** Do not work on the system or connect or disconnect cables during periods of lightning activity, rainy weather, or both.



**DANGER – L'HASARD DU TENSION ÉLEVÉ :** Ne pas travailler sur le système ni brancher ni débrancher les câbles durant l'activité de la foudre, par de temps pluvieux, ou tous le deux.

- 1 Set the – 48 Vdc power source to ON.
- 2 Set the multimeter to DC voltage.
- 3 At the mounting location, connect a black test lead from the **negative** input of the multimeter to pin **B** on the power cable (see Figure 3-5).

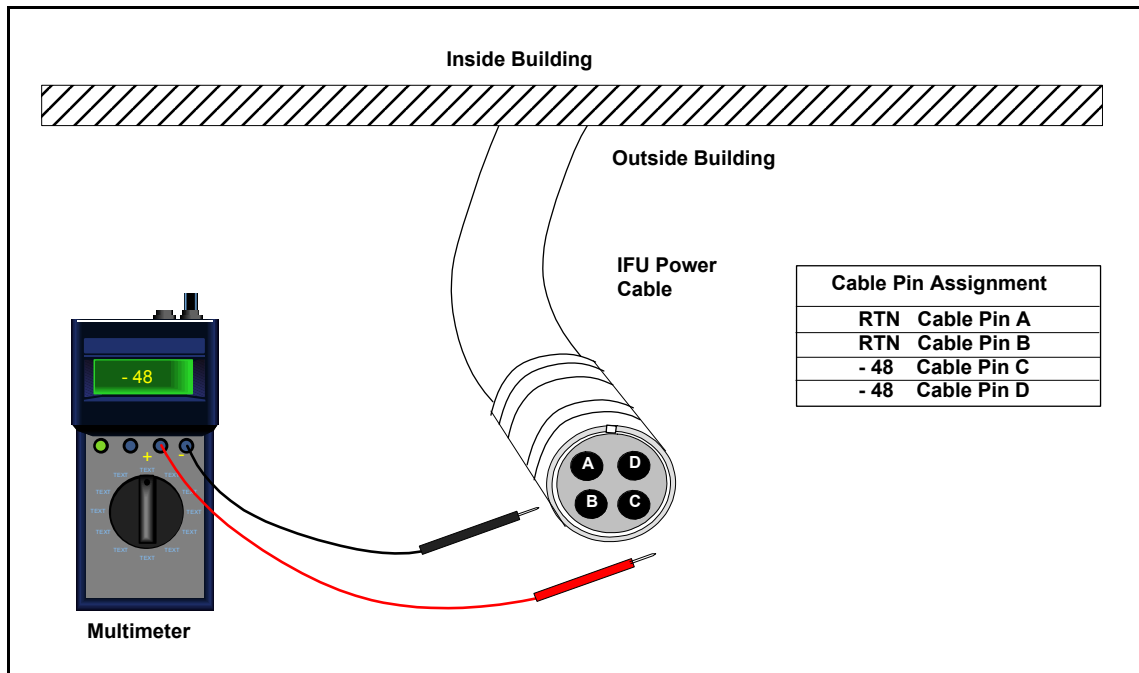

Figure 3-5. Power Test Setup

- 4 Connect a red test lead from the **positive** input of the multimeter to pin **D** on the power cable. Record the results in Table A-1 on page A-2.
- 5 Read the measurement on the multimeter. Passing criteria is – 46 Vdc to – 56 Vdc. Record the results in Table A-1 on page A-2.
- 6 Connect a black test lead from the **negative** input of the multimeter to pin **A** on the power cable.
- 7 Connect a red test lead from the **positive** input of the multimeter to pin **C** on the power cable.
- 8 Read the measurement on the multimeter. Passing criteria is – 46 Vdc to – 56 Vdc. Record the results in Table A-1 on page A-2.

Repeat the above test for each IFU power cable.

---

## Installing the Fiber Optic Cable

There are two fiber optic cable routes as follows:

- The IFU Alpha fiber optic cable runs from the IFU mounting location to the demarcation box.
- The IFU Beta fiber optic cable runs from the IFU mounting location to the demarcation box.

► **To install the fiber optic cable:**



**WARNING:** Never touch exposed fiber with any part of your body. Fiber fragments can enter the skin and are difficult to detect and remove.

**AVERTISSEMENT :** Ne jamais laisser une fibre nue entrer en contact avec une partie quelconque du corps. Des fragments de fibre peuvent entrer dans la peau, et sont difficiles à déceler et à enlever.

---



**DANGER:** Invisible laser radiation. Avoid direct eye exposure to the end of a fiber, fiber cord, or fiber pigtail. The infrared light used in fiber optics systems is invisible, but can cause serious injury to the eye.

**AVERTISSEMENT :** Rayonnement laser invisible. Éviter l'exposition directe des yeux à l'extrémité d'une fibre, d'un cordon à fibres ou d'une fibre amorce. La lumière infrarouge utilisée dans les systèmes à fibres optiques est invisible, mais peut provoquer des lésions graves aux yeux.

---



**CAUTION:** Ensure the outside optical fiber connectors are environmentally protected. Failure to do so may cause contamination of the fiber surfaces.

**MISE EN GARDE :** S'assurer que les raccords extérieurs fibre optique sont protégés contre l'environnement. L'absence d'une telle protection peut entraîner la contamination des surfaces des fibres.

---

---

**CAUTION:** To reduce the risk of fiber optic cable damage, use the following bend radius guidelines for indoor/outdoor fiber optic cable:

- Long-term (installed): bend radius is equal to 10 times the diameter of the cable.
- Short-term (during installation): bend radius is equal to 20 times the diameter of the cable.



**MISE EN GARDE :** Pour réduire le risque de dommage aux câbles à fibres optiques, suivre les consignes suivantes en matière de rayon de courbure des câbles à fibres optiques extérieurs ou intérieurs :

- Courbure à long terme (installée). Le rayon de courbure ne doit pas dépasser 10 fois le diamètre du câble.
- Courbure à court terme (pendant l'installation). Le rayon de courbure ne doit pas dépasser 20 fois le diamètre du câble.

- 
- 1 Route the IFU fiber optic cables from each of the IFU mounting locations to the demarcation box. Refer to the site drawing in the site engineering folder for the specific route.

**NOTE:** Allow an extra three-foot service loop at both ends. Use large radius bends to avoid crimping and kinking the cables during the cable routing.

- 2 Connect the IFU fiber optic cables to the rear side of the demarcation patch panel as shown in Figure 3-6 and Table 3-4.

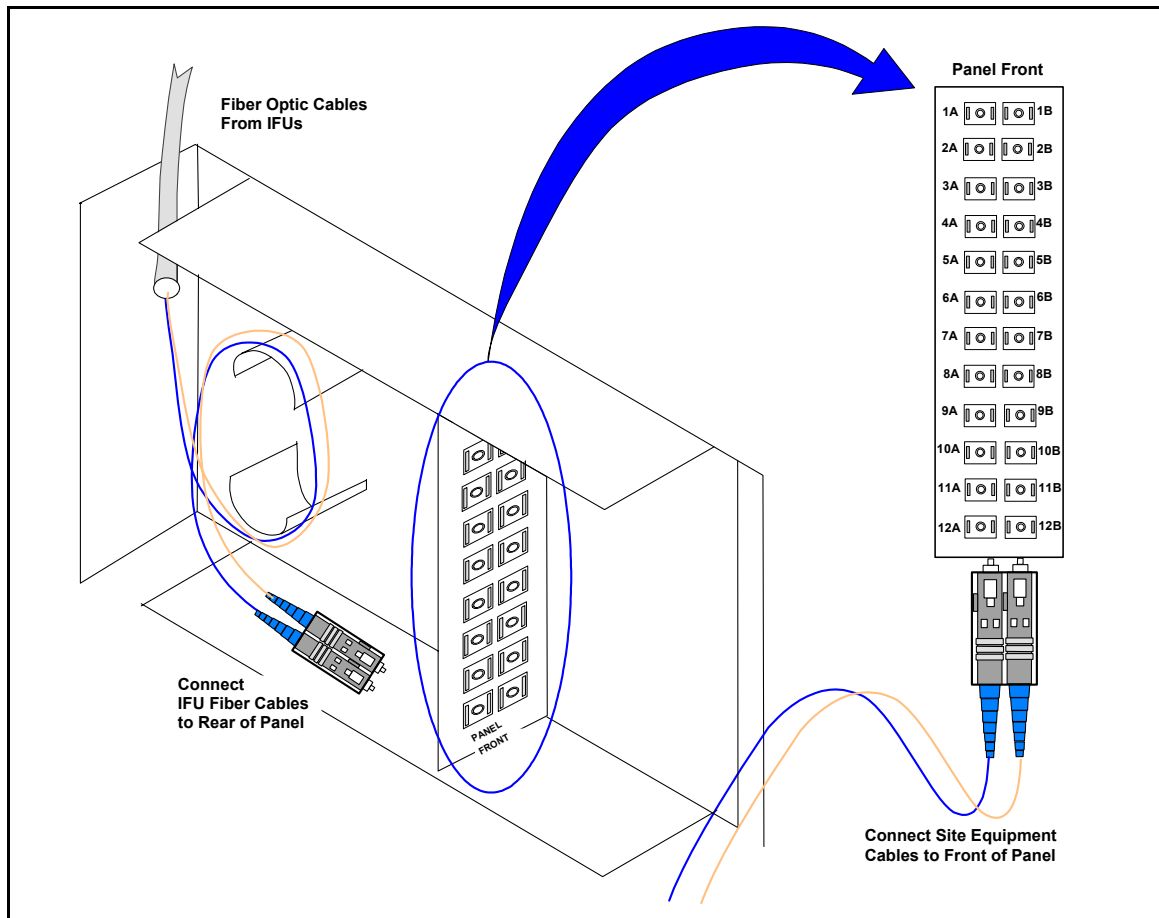
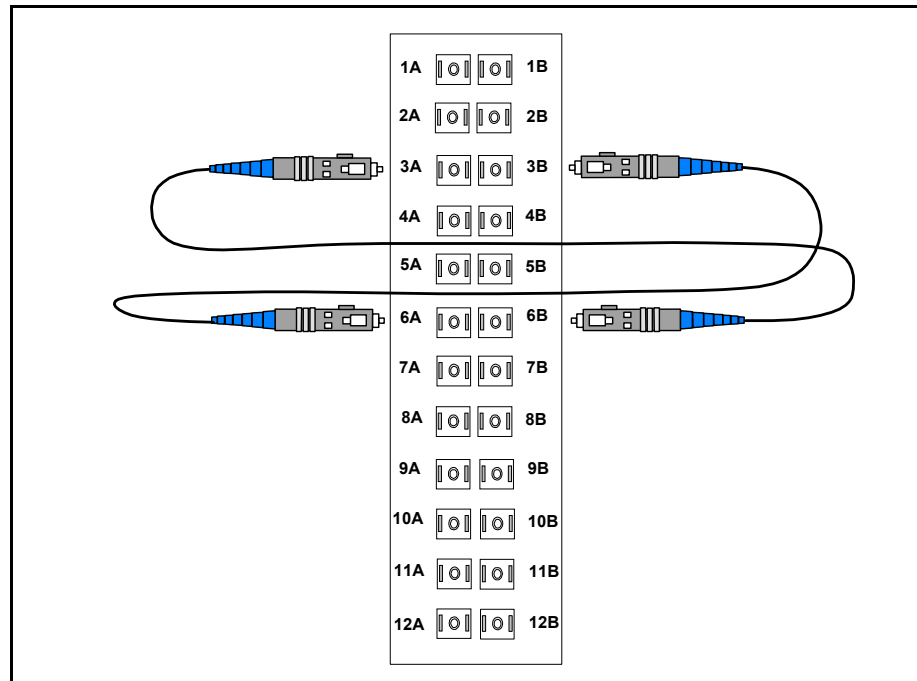

Figure 3-6. Demarcation Patch Panel

**Table 3-4.** Typical SONET OC-3 Demarcation Panel Input Connections

Fiber Function	Fiber Color (Number)	Rear of Demarcation Panel	Fiber Type
<b>IFU Alpha</b>			
Payload TX	Slate (FA-1)	1A	Single-mode
Payload RX	White (FA-2)	1B	Single-mode
OAM&P TX	Green (FA-5)	2A	Multi-mode
OAM&P RX	Brown (FA-6)	2B	Multi-mode
Interconnect TX	Blue (FA-7)	3A	Multi-mode
Interconnect RX	Orange (FA-8)	3B	Multi-mode
<b>IFU Beta</b>			
Payload TX	Slate (FB-1)	4A	Single-mode
Payload RX	White (FB-2)	4B	Single-mode
OAM&P TX	Green (FB-5)	5A	Multi-mode
OAM&P RX	Brown (FB-6)	5B	Multi-mode
Interconnect TX	Blue (FB-7)	6A	Multi-mode
Interconnect RX	Orange (FB-8)	6B	Multi-mode

- 3** Connect the jumpers to the front of the demarcation patch panel as shown in Figure 3-7 ,Table 3-5, and Figure 3-8.



**Figure 3-7.** Typical SONET OC-3 Demarcation Jumper Locations

**Table 3-5.** Typical SONET OC-3 Demarcation Panel Jumper Connections

Fiber Function	From	To	Fiber Function
IFU Alpha Interconnect TX	3A	6B	IFU Beta Interconnect RX
IFU Alpha Interconnect RX	3B	6A	IFU Beta Interconnect TX

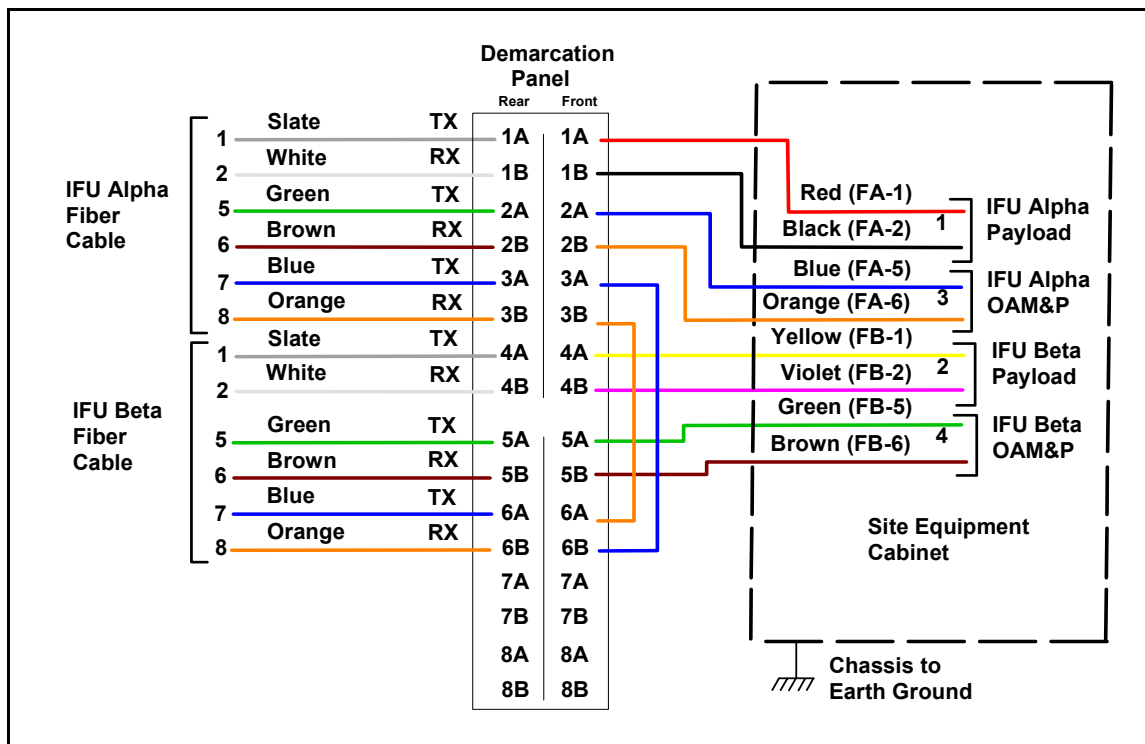

Figure 3-8. Typical SONET OC-3 Site Schematic

## Fiber Optic Continuity Test

This test is to ensure that the signal loss in the fiber optic assemblies meets the required specifications and that cables have not been damaged during installation. The fiber optic continuity test consists of the following:

- 1 Cleaning the fiber optic cable
- 2 Testing the fiber optic cable



---

► **To clean the fiber optic cable:**



**WARNING:** Never touch exposed fiber with any part of your body. Fiber fragments can enter the skin and are difficult to detect and remove.

**AVERTISSEMENT :** Ne jamais laisser une fibre nue entrer en contact avec une partie quelconque du corps. Des fragments de fibre peuvent entrer dans la peau, et sont difficiles à déceler et à enlever.

---



**DANGER:** Invisible laser radiation. Avoid direct eye exposure to the end of a fiber, fiber cord, or fiber pigtail. The infrared light used in fiber optics systems is invisible, but can cause serious injury to the eye.

**AVERTISSEMENT :** Rayonnement laser invisible. Éviter l'exposition directe des yeux à l'extrémité d'une fibre, d'un cordon à fibres ou d'une fibre amorce. La lumière infrarouge utilisée dans les systèmes à fibres optiques est invisible, mais peut provoquer des lésions graves aux yeux.

---



**CAUTION:** Ensure the outside optical fiber connectors are environmentally protected. Failure to do so may cause contamination of the fiber surfaces.

**MISE EN GARDE :** S'assurer que les raccords extérieurs fibre optique sont protégés contre l'environnement. L'absence d'une telle protection peut entraîner la contamination des surfaces des fibres.

---

---

**CAUTION:** To reduce the risk of fiber optic cable damage, use the following bend radius guidelines for indoor/outdoor fiber optic cable:

- Long-term (installed): bend radius is equal to 10 times the diameter of the cable.
- Short-term (during installation): bend radius is equal to 20 times the diameter of the cable.



**MISE EN GARDE :** Pour réduire le risque de dommage aux câbles à fibres optiques, suivre les consignes suivantes en matière de rayon de courbure des câbles à fibres optiques extérieurs ou intérieurs :

- Courbure à long terme (installée). Le rayon de courbure ne doit pas dépasser 10 fois le diamètre du câble.
- Courbure à court terme (pendant l'installation). Le rayon de courbure ne doit pas dépasser 20 fois le diamètre du câble.

- 
- 1 Remove the dust cap on the connector. Using the automatic cleaner, wipe the connector once in each direction across the cleaning pad.
  - 2 With canned air, blow a slow three- to four-second burst of air across the fiber/ferrule end face to dry the connector.
  - 3 Replace the dust cap.
  - 4 Repeat Step 1 through Step 3 on the other end of the fiber optic cable.

**NOTE:** Never leave connectors unprotected after cleaning.

- 5 Attach the fiber optic cable to the scope and inspect for dirt, grease, defects, dust, oil, etc.
- 6 Repeat Step 1 and Step 2 if necessary.

► **To test the fiber optic cable:**

- 1 Connect the SONET OC-3 FSI test cable to the IFU Alpha and IFU Beta fiber cables.

**NOTE:** Never connect the transmitter first.

- 2 Connect the optical power meter to the IFU Beta test adapter (see Figure 3-9 and Table 3-6).

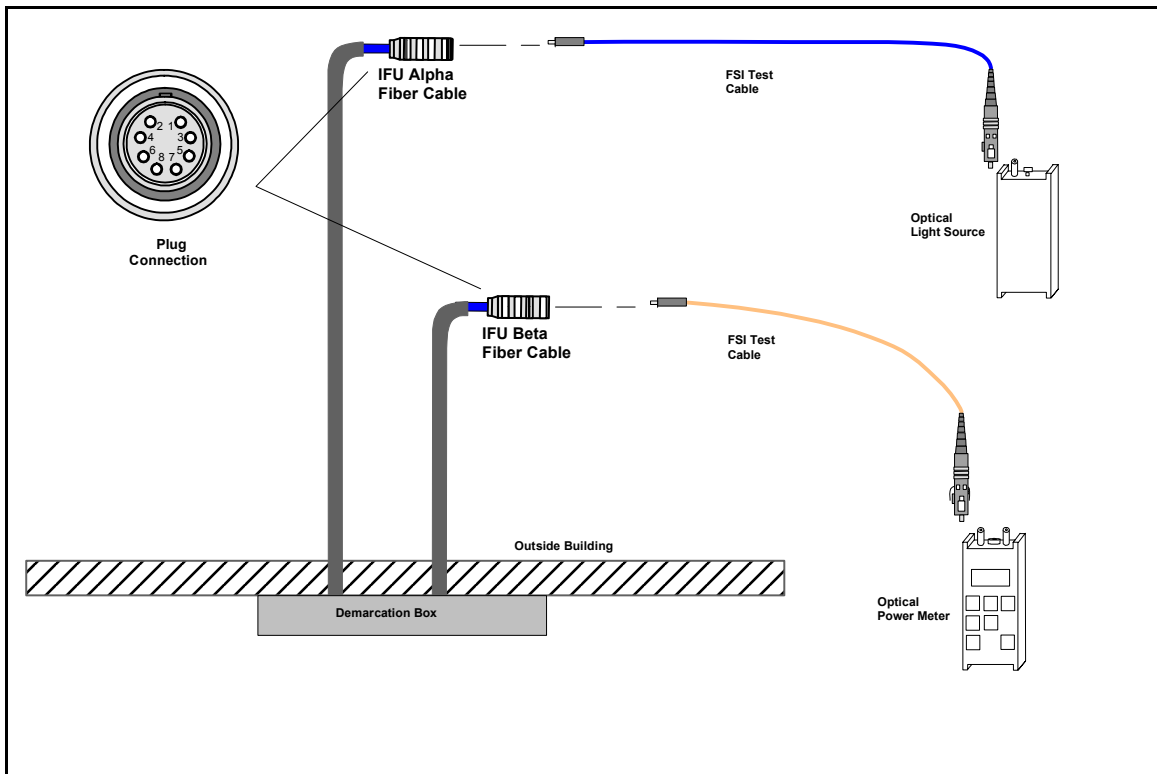

**Figure 3-9.** SONET OC-3 Fiber Optic Continuity Test Setup

**Table 3-6.** SONET OC-3 Fiber Test Connections

IFU Alpha Fiber Name	IFU Alpha Test Adapter Connector	IFU Beta Test Adapter Connector	IFU Beta Fiber Name
IFU Alpha Interconnect TX	7	8	IFU Beta Interconnect RX
IFU Alpha Interconnect RX	8	7	IFU Beta Interconnect TX

- 3 Connect the optical light source to the IFU Alpha test adapter as called out in Table 3-6.
- 4 Set the optical light source to 0 dBm continuous wave and 1310 nm.
- 5 Turn on the optical power meter and optical light source and take readings at the power meter. Record the results in Table A-2 on page A-2.

**NOTE:** The received signal should be stronger than  $-5.0$  dBm (less than  $5.0$  dBm).

Repeat Steps 1 through 5 on each fiber optic cable.

## Installing an IFU

IFUs are installed in the locations specified by each site drawing. A near-end IFU is the first installed IFU in a pair, and the far-end IFU is the second in the pair. Figure 3-10 provides a close-up view of an installed IFU. Installing an IFU is a two-part process that consists of the following:

- 1 Mounting the IFU to the mounting bracket
- 2 Attaching cables to the IFU

---

**CAUTION – LIFTING HAZARD:** Two people are required to lift the Invisible Fiber™ unit. Grasp the Invisible Fiber™ unit underneath the lower edge and lift with both hands. To prevent injury, keep your back straight and lift with your legs, not your back. To prevent damage to the Invisible Fiber™ unit and components, never attempt to lift the radio by the attached cables.



**MISE EN GARDE – DANGER DE LEVAGE :** Il faut deux personnes pour soulever l'unité Invisible Fiber<sup>MD</sup>. Saisir l'unité Invisible Fiber<sup>MD</sup> au-dessous du rebord inférieur, puis soulever l'unité avec les deux mains. Pour éviter les lésions corporelles, garder le dos en position verticale et soulever l'unité en utilisant les jambes et non pas les reins. Pour éviter l'endommagement de l'unité Invisible Fiber<sup>MD</sup> et de ses composants, ne jamais essayer de soulever la radio en tirant sur les câbles qui y sont attachés.

---

**CAUTION:** Keep tools and parts away from walkways. When carrying large, heavy equipment (such as the Invisible Fiber™ unit), obstacles (such as hand tools, cables, or components) may not be easily visible and can cause accidents.



**MISE EN GARDE :** Garder les outils et les pièces loin des allées. Lorsqu'on transporte des équipements lourds et à grandes dimensions (tels que l'unité Invisible Fiber<sup>MD</sup>), les obstacles (tels que les outils à main, les câbles ou les composants) sont parfois difficiles à voir et peuvent causer des accidents.

---

► **To mount the IFU:**

- 1 Verify the correct IFU for a location by checking the product number on the IFU against the site drawing in the site engineering folder.
- 2 Refer to Figure 3-10 and position the IFU (2) on the mounting studs (7) and engage the top clamp.
- 3 Install a snap ring (3) on each mounting stud (7).

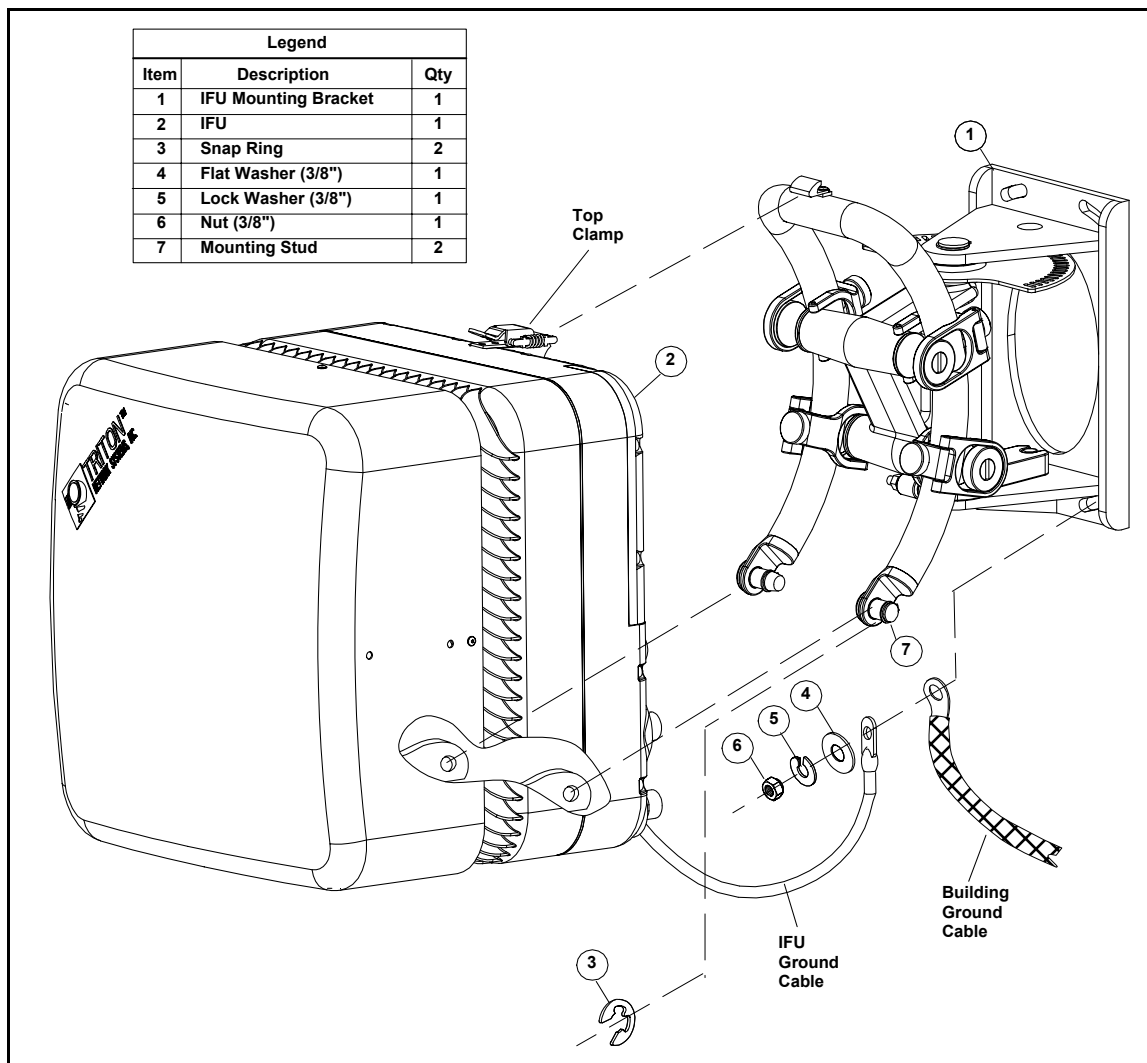

**Figure 3-10.** Mounting the IFU

- 4 Position the building ground cable, IFU ground cable, flat washer (4), and lock washer (5) on the bottom bolt of the mounting bracket (1) and install the nut (6).

## Attaching IFU Cables

- To attach the IFU cables:



**DANGER – HIGH CURRENT HAZARD:** Ensure that the – 48 Vdc power source is set to the OFF position before beginning the installation procedures for the Invisible Fiber™ unit.

**DANGER – L'HASARD DU COURANT ÉLEVÉ :** S'assurer que le bloc d'alimentation – 48 V CC est en position HORS TENSION avant d'aborder les procédures pour l'installation de l'unité Invisible Fiber<sup>MD</sup>.

- 1 Connect the power and fiber optic cable to the IFU locations as shown in Figure 3-11.

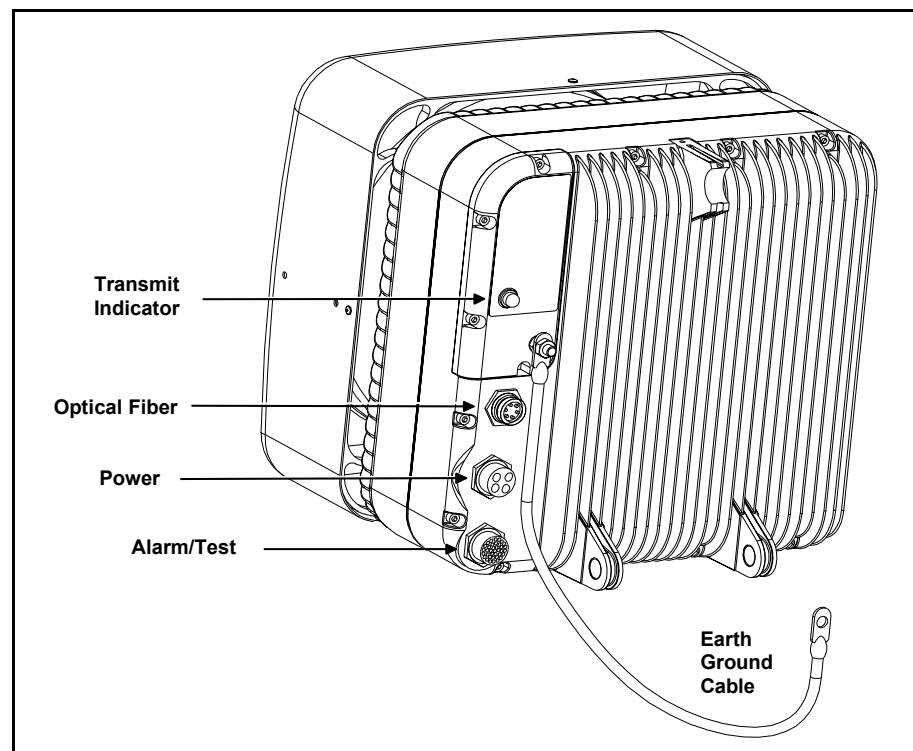

**Figure 3-11.** IFU Cable Connections

- 2 Secure the power and fiber optic cables to the building with tie-wraps as needed.







# Alignment Procedures

This chapter provides the procedures for aligning IFUs.

---

**NOTE:** Observe all federal and local laws, regulations, electrical codes, building codes, fire codes, and licensing agreements.

Il faut respecter l'ensemble des lois, règlements, codes d'électricité, codes du bâtiment et codes des incendies du gouvernement fédéral et des municipalités ainsi que tous les contrats de licence.

---

**NOTE:** Failure to follow the installation procedure described in the Triton Network Systems' product documentation may result in damage to the Invisible Fiber™ unit and render the unit unusable.

L'inobservation de la procédure d'installation décrite dans la documentation du produit fournie par la société Triton Network Systems peut endommager l'unité Invisible Fiber<sup>MD</sup> et la rendre inutilisable.

---

The following topics are included in this chapter:

- Course aligning the IFU
- Fine aligning the IFU

## Setup

### Before Starting

Before starting the procedures in this chapter, ensure that the IFUs have been mounted at the near-end site and far-end site, and that the cables have been tested.

### Preparing for Installation

Table 4-1 identifies the basic aligning tools required for aligning the near-end and far-end sites.

**Table 4-1.** Site Aligning Tools

Item No.	Description	Qty.
1	IFU Link Manager test cable	2
2	IFU Link Manager software	2
3	Laptop with IFU Link Manager installed	2
4	SONET test set	2
5	Digital multimeter (measures DC voltage up to 100V, accuracy 0.3% or better)	2
6	BNC-banana interface cable	1
7	Site engineering folder	1
8	9/16 in. wrenches or sockets	2
9	Optical alignment tool	1

## Coarse Aligning the IFU

► To align the IFU:



**DANGER – HIGH VOLTAGE HAZARD:** Do not work on the system or connect or disconnect cables during periods of lightning activity, rainy weather, or both.

**DANGER – L'HASARD DU TENSION ÉLEVÉ :** Ne pas travailler sur le système ni brancher ni débrancher les câbles durant l'activité de la foudre, par de temps pluvieux, ou tous le deux.



**WARNING:** Failure to follow operating instructions could result in death or serious injury.

**AVERTISSEMENT :** Ne pas suivre les instructions d'utilisation peut causer de sérieuses blessures et même la mort.

- 1 Loosen the four vertical alignment screws on the IFU mounting bracket.
- 2 Coarse align the near-end IFU to the far-end IFU pair and the far-end IFU to the near-end IFU using an optical alignment tool (see Figure 4-1).

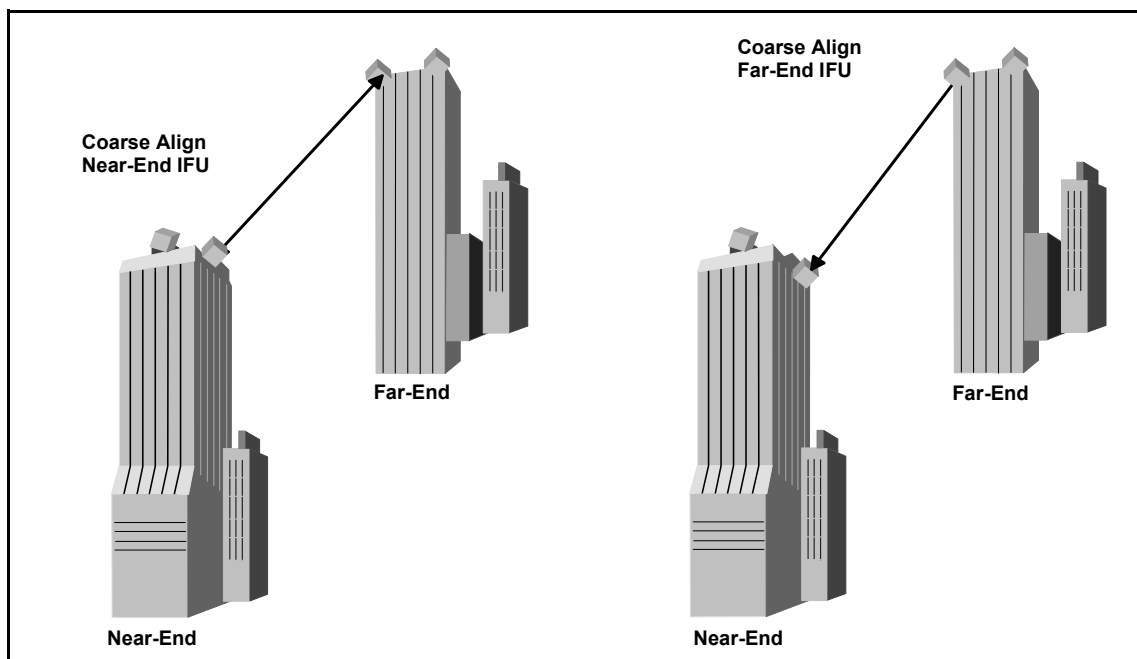

Figure 4-1. Coarse Alignment

- 3 Loosen the horizontal alignment nut on the holding bracket. Coarse align the near-end IFU to the designated far-end IFU using an optical alignment tool.
- 4 Tighten the four vertical screws and single horizontal nut on the IFU mounting bracket.
- 5 Set the – 48 Vdc power source to ON.
- 6 Remove the protective cap from the IFU test connector.



---

**DANGER – HIGH CURRENT HAZARD:** Do not turn on power before reading the Triton Network Systems' product documentation. This device has a – 48 Vdc (5 amps operating peak per feed) direct current input.

**DANGER – L'HASARD DU COURANT ÉLEVÉ :** Ne pas mettre la tension avant de lire la documentation du produit fournie par la société Triton Network Systems. Cet appareil a une alimentation directe de – 48 V CC (courant de pointe de 5 ampères par ligne d'alimentation).

---

- 7 Connect the IFU test cable to the test port of the near-end IFU (see Figure 4-2).

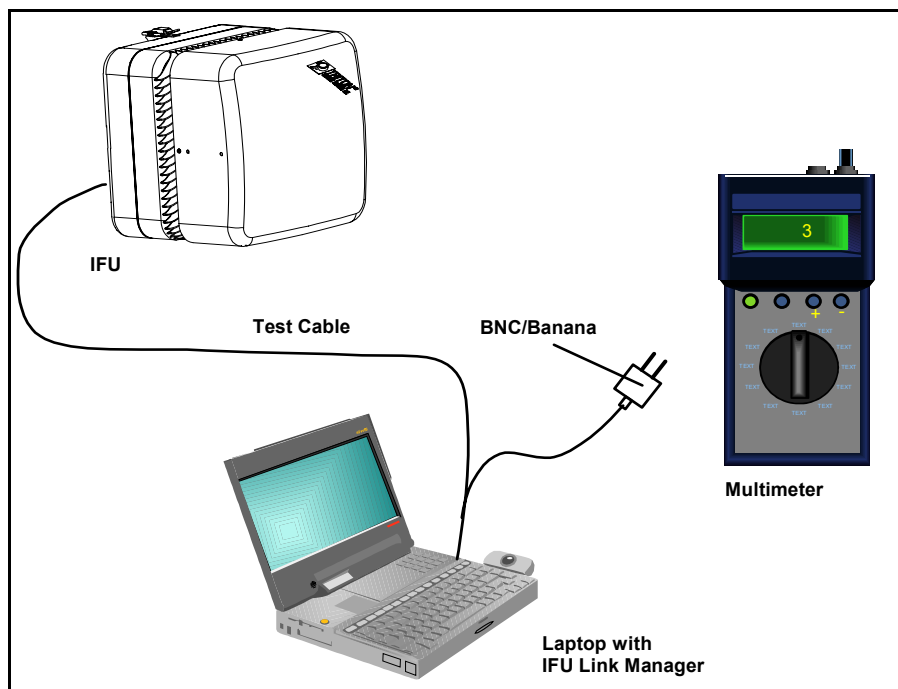

Figure 4-2. Alignment Test Setup

- 8 Connect the BNC plug of the test cable to the BNC-banana interface cable.
- 9 Connect the banana plug of the BNC-banana interface cable to the multimeter (red plug to the volt terminal, black plug to the common terminal).
- 10 Turn on the multimeter and set it up to measure DC voltage.
- 11 Connect the RJ-45 plug of the test cable to the laptop computer.
- 12 Power up the laptop computer and access the IFU Link Manager application. Initialize the IFU if it has not been initialized (refer to IFU Link Manager online help.)
- 13 Log on to the near-end IFU.
- 14 Use the IFU Link Manager application to set the near-end IFU radio transmitter to ON (refer to IFU Link Manager online help).
- 15 Ensure that the Adaptive Transmit Power Control is OFF.

Repeat this procedure for the far-end IFU.



**WARNING:** Beware! Radio transmitter is ON when the red light indicator on the back side of the Invisible Fiber™ unit is illuminated. Observe all radio frequency energy exposure and service interruption cautions.

**MISE EN GARDE :** Attention ! Le poste émetteur est EN MARCHE lorsque le témoin rouge sur le dos de l'unité Invisible Fiber<sup>MD</sup> est allumé. Respecter toutes les mises en garde concernant l'exposition aux radiofréquences et l'interruption de service.

---



**WARNING – Radio Frequency energy:** To comply with FCC and Health Canada RF exposure requirements, a minimum separation distance of 40 feet in front of the Invisible Fiber™ unit is required between this antenna and all persons while the transmitter is ON. The radio transmitter is ON when the red light indicator on the back side of the radio enclosure is illuminated. Observe RF energy exposure safety limits, applicable rules, and service interruption cautions in the product manuals. Serious bodily injury may result.

**AVERTISSEMENT : ENERGIE AUX FRÉQUENCES RADIOÉLECTRIQUES :** afin d'être conforme aux exigences concernant l'exposition RF du FCC et du Ministère de la Santé Canadien, une distance de séparation minimale de 40 pieds devant l'appareil Invisible Fiber™ est nécessaire entre cette antenne et toute personne présente lorsque l'émetteur est allumé (ON). L'émetteur radio est allumé (ON) lorsque le voyant lumineux rouge situé au dos du boîtier radioélectrique est illuminé. Veuillez observer les limites de sécurité concernant l'exposition RF, les règles applicables et les avertissements d'interruption de service indiqués dans les manuels d'utilisation fournis avec le produit. Le non respect de ces mesures de sécurité risquerait d'entraîner des blessures corporelles grave.

## Fine Aligning the IFU

### ► To align the far-end IFU:

- 1 Ensure the near-end IFU transmitter is set to ON.



**WARNING:** Beware! Radio transmitter is ON when the red light indicator on the back side of the Invisible Fiber™ unit is illuminated. Observe all radio frequency energy exposure and service interruption cautions.

**MISE EN GARDE :** Attention ! Le poste émetteur est EN MARCHÉ lorsque le témoin rouge sur le dos de l'unité Invisible Fiber™ est allumé. Respecter toutes les mises en garde concernant l'exposition aux radiofréquences et l'interruption de service.



**WARNING – Radio Frequency energy:** To comply with FCC and Health Canada RF exposure requirements, a minimum separation distance of 40 feet in front of the Invisible Fiber™ unit is required between this antenna and all persons while the transmitter is ON. The radio transmitter is ON when the red light indicator on the back side of the radio enclosure is illuminated. Observe RF energy exposure safety limits, applicable rules, and service interruption cautions in the product manuals. Serious bodily injury may result.

**AVERTISSEMENT : ENERGIE AUX FRÉQUENCES RADIOÉLECTRIQUES :** afin d'être conforme aux exigences concernant l'exposition RF du FCC et du Ministère de la Santé Canadien, une distance de séparation minimale de 40 pieds devant l'appareil Invisible Fiber™ est nécessaire entre cette antenne et toute personne présente lorsque l'émetteur est allumé (ON). L'émetteur radio est allumé (ON) lorsque le voyant lumineux rouge situé au dos du boîtier radioélectrique est illuminé. Veuillez observer les limites de sécurité concernant l'exposition RF, les règles applicables et les avertissements d'interruption de service indiqués dans les manuels d'utilisation fournis avec le produit. Le non respect de ces mesures de sécurité risquerait d'entraîner des blessures corporelles grave.

- 2 Loosen the four vertical screws on the holding bracket.

- 3** While viewing the multimeter, sweep the IFU vertically by pointing the IFU all the way up and then down. The measured voltage of the multimeter displays a succession of peak signals as the IFU moves. Specifically, the signal displays a “small” peak, a relatively higher peak, and then redisplay the “small” peak. When the higher peak occurs, note the approximate position of the IFU and the corresponding voltage value. The peak voltage should be approximately 3 Vdc.
- 4** Move the IFU to the higher peak position as indicated by the multimeter display.
- 5** Tighten the four vertical screws on the IFU mounting bracket.
- 6** Loosen the horizontal alignment nut on the IFU mounting bracket.
- 7** Sweep the IFU from the far left to the far right. The measured voltage of the multimeter displays a succession of peak signals as the IFU moves. When the higher peak occurs, note the approximate position of the IFU and the corresponding voltage value.
- 8** Move the IFU to the higher peak position as indicated by the multimeter display.
- 9** Tighten the horizontal alignment nut on the IFU mounting bracket.



► **To align the near-end IFU:**

- 1 Ensure the far-end IFU transmitter is set to ON.



**WARNING:** Beware! Radio transmitter is ON when the red light indicator on the back side of the Invisible Fiber™ unit is illuminated. Observe all radio frequency energy exposure and service interruption cautions.

**MISE EN GARDE :** Attention ! Le poste émetteur est EN MARCHÉ lorsque le témoin rouge sur le dos de l'unité Invisible Fiber<sup>MD</sup> est allumé. Respecter toutes les mises en garde concernant l'exposition aux radiofréquences et l'interruption de service.



**WARNING – Radio Frequency energy:** To comply with FCC and Health Canada RF exposure requirements, a minimum separation distance of 40 feet in front of the Invisible Fiber™ unit is required between this antenna and all persons while the transmitter is ON. The radio transmitter is ON when the red light indicator on the back side of the radio enclosure is illuminated. Observe RF energy exposure safety limits, applicable rules, and service interruption cautions in the product manuals. Serious bodily injury may result.

**AVERTISSEMENT : ENERGIE AUX FRÉQUENCES RADIOÉLECTRIQUES :** afin d'être conforme aux exigences concernant l'exposition RF du FCC et du Ministère de la Santé Canadien, une distance de séparation minimale de 40 pieds devant l'appareil Invisible Fiber™ est nécessaire entre cette antenne et toute personne présente lorsque l'émetteur est allumé (ON). L'émetteur radio est allumé (ON) lorsque le voyant lumineux rouge situé au dos du boîtier radioélectrique est illuminé. Veuillez observer les limites de sécurité concernant l'exposition RF, les règles applicables et les avertissements d'interruption de service indiqués dans les manuels d'utilisation fournis avec le produit. Le non respect de ces mesures de sécurité risquerait d'entraîner des blessures corporelles grave.

- 2 Loosen the four vertical screws on the IFU mounting bracket.

- 3 While viewing the multimeter, sweep the IFU vertically by pointing the IFU all the way up and then down. The measured voltage of the multimeter displays a succession of peak signals as the IFU moves. Specifically, the signal displays a “small” peak, a relatively higher peak, and then redisplay the “small” peak. When the higher peak occurs, note the approximate position of the IFU and the corresponding voltage value. The peak voltage should be approximately 3 Vdc.
- 4 Move the IFU to the higher peak position as indicated by the multimeter display.
- 5 Tighten the four vertical screws on the IFU mounting bracket.
- 6 Loosen the horizontal alignment nut on the IFU mounting bracket.
- 7 Sweep the IFU from the far left to the far right. The measured voltage of the multimeter displays a succession of peak signals as the IFU moves. When the higher peak occurs, note the approximate position of the IFU and the corresponding voltage value.
- 8 Move the IFU to the higher peak position as indicated by the multimeter display.
- 9 Tighten the horizontal alignment nut on the IFU mounting bracket.
- 10 Access the IFU Link Manager application and enable Adaptive Transmit Power Control for both the near-end and the far-end IFUs (refer to IFU Link Manager online help).
- 11 Record the minimum, maximum, and actual RSSI levels set for the IFU in Table A-3 on page A-2 and Table A-5 on page A-3.
- 12 Turn off the laptop computers, disconnect the test cables, and replace the protective caps on the IFU test connectors.
- 13 Secure all IFU cabling with UV-rated tie-wraps. Continue to tie wrap the cables every 18 inches until they enter the building.

**NOTE:** Refer to your project manager or liaison for commissioning procedures applicable to your network.



## Removing an IFU

This chapter provides the procedures for removing an IFU.

---

**NOTE:** Observe all federal and local laws, regulations, electrical codes, building codes, fire codes, and licensing agreements.

Il faut respecter l'ensemble des lois, règlements, codes d'électricité, codes du bâtiment et codes des incendies du gouvernement fédéral et des municipalités ainsi que tous les contrats de licence.

---

**NOTE:** Failure to follow the installation procedure described in the Triton Network Systems' product documentation may result in damage to the Invisible Fiber™ unit and render the unit unusable. Read through the entire installation procedure before beginning installation.

L'inobservation de la procédure d'installation décrite dans la documentation du produit fournie par la société Triton Network Systems peut endommager l'unité Invisible Fiber<sup>MD</sup> et la rendre inutilisable.

---

**CAUTION:** The Invisible Fiber™ unit contains no owner or user serviceable parts. Opening the radio unit or tampering with any of its seals voids all warranties.



**MISE EN GARDE :** L'unité Invisible Fiber<sup>MD</sup> contient pas de parts utilisés par le propriétaire ou l'utilisateur. Ouverture de l'unité de la radio ou toucher aux scelles rend toute garantie nulle et non avenue.

---

The following topics are included in this chapter:

- Servicing an IFU
- Removing an IFU

## Servicing an IFU

Servicing an IFU is done at the factory. To service the IFU, remove it and replace it with a new IFU. Send the IFU requiring service to the factory (See *Contacting Triton Network Systems, Inc.* on page xiii).

## Removing an IFU

Removing an IFU is a two-part process:

- 1 Removing the power and fiber optic cables from the IFU.
- 2 Removing the IFU from the mounting bracket.

## Removing Cables

- To remove power and fiber optic cables from the IFU:



**CAUTION:** Ensure that the – 48 Vdc power source is set to the OFF position before attaching power cables to the Invisible Fiber™ unit.

**MISE EN GARDE :** S'assurer que le bloc d'alimentation – 48 V CC est en position HORS TENSION avant d'attacher les câbles d'alimentation à l'unité Invisible Fiber<sup>MD</sup>.

---



**WARNING:** Never touch exposed fiber with any part of your body. Fiber fragments can enter the skin and are difficult to detect and remove.

**AVERTISSEMENT :** Ne jamais laisser une fibre nue entrer en contact avec une partie quelconque du corps. Des fragments de fibre peuvent entrer dans la peau, et sont difficiles à déceler et à enlever.

---



**CAUTION:** Ensure the outside optical fiber connectors are environmentally protected. Failure to do so may cause contamination of the fiber surfaces.

**MISE EN GARDE :** S'assurer que les raccords extérieurs fibre optique sont protégés contre l'environnement. L'absence d'une telle protection peut entraîner la contamination des surfaces des fibres.

- 1 Set the – 48 Vdc power source or contact breaker to the OFF position for the IFU to be removed.
- 2 Remove the power and fiber optic cables from the IFU locations as shown in Figure 5-1.
- 3 Replace dust caps on the exposed IFU and cable connectors.

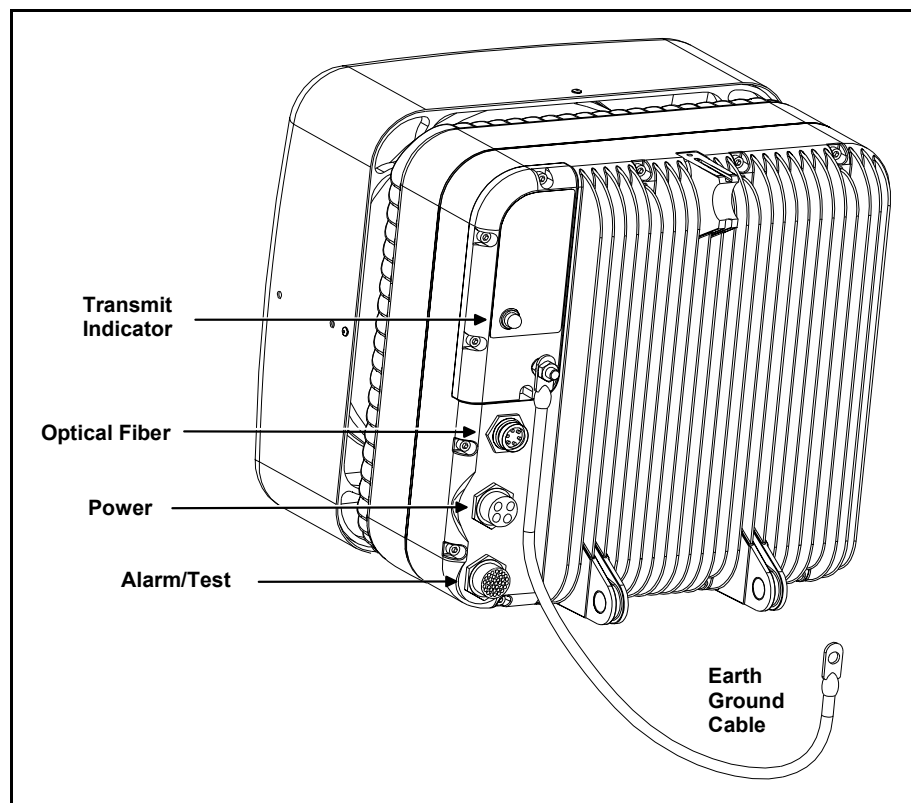

**Figure 5-1.** IFU Cable Connections

## Removing an IFU from a Mounting Bracket

► **To remove an IFU from its mounting bracket:**

- 1 Remove the nut (6), lock washer (5), flat washer (4), and earth ground strap from the bottom bolt of the mounting bracket (1) (see Figure 5-2).



---

**CAUTION:** Lifting hazard: Two people are required to lift the Invisible Fiber™ unit. Grasp the Invisible Fiber™ unit underneath the lower edge and lift with both hands. To prevent injury, keep your back straight and lift with your legs, not your back. To prevent damage to the Invisible Fiber™ unit and components, never attempt to lift the radio by the attached cables.

**MISE EN GARDE :** Danger de levage. Il faut deux personnes pour soulever l'unité Invisible Fiber<sup>MD</sup>. Saisir l'unité Invisible Fiber<sup>MD</sup> au-dessous du rebord inférieur, puis soulever l'unité avec les deux mains. Pour éviter les lésions corporelles, garder le dos en position verticale et soulever l'unité en utilisant les jambes et non pas les reins. Pour éviter l'endommagement de l'unité Invisible Fiber<sup>MD</sup> et de ses composants, ne jamais essayer de soulever la radio en tirant sur les câbles qui y sont attachés.

---



---

**CAUTION:** Keep tools and parts away from walkways. When carrying large, heavy equipment (such as the Invisible Fiber™ unit), obstacles (such as hand tools, cables, or components) may not be easily visible and can cause accidents.

**MISE EN GARDE :** Garder les outils et les pièces loin des allées. Lorsqu'on transporte des équipements lourds et à grandes dimensions (tels que l'unité Invisible Fiber<sup>MD</sup>), les obstacles (tels que les outils à main, les câbles ou les composants) sont parfois difficiles à voir et peuvent causer des accidents.

---

- 2 Remove the two snap rings (3) from the mounting studs (7) as shown in Figure 5-2.
- 3 Disengage the top IFU clamp and remove the IFU (2) from the mounting bracket (1) as shown in Figure 5-2.

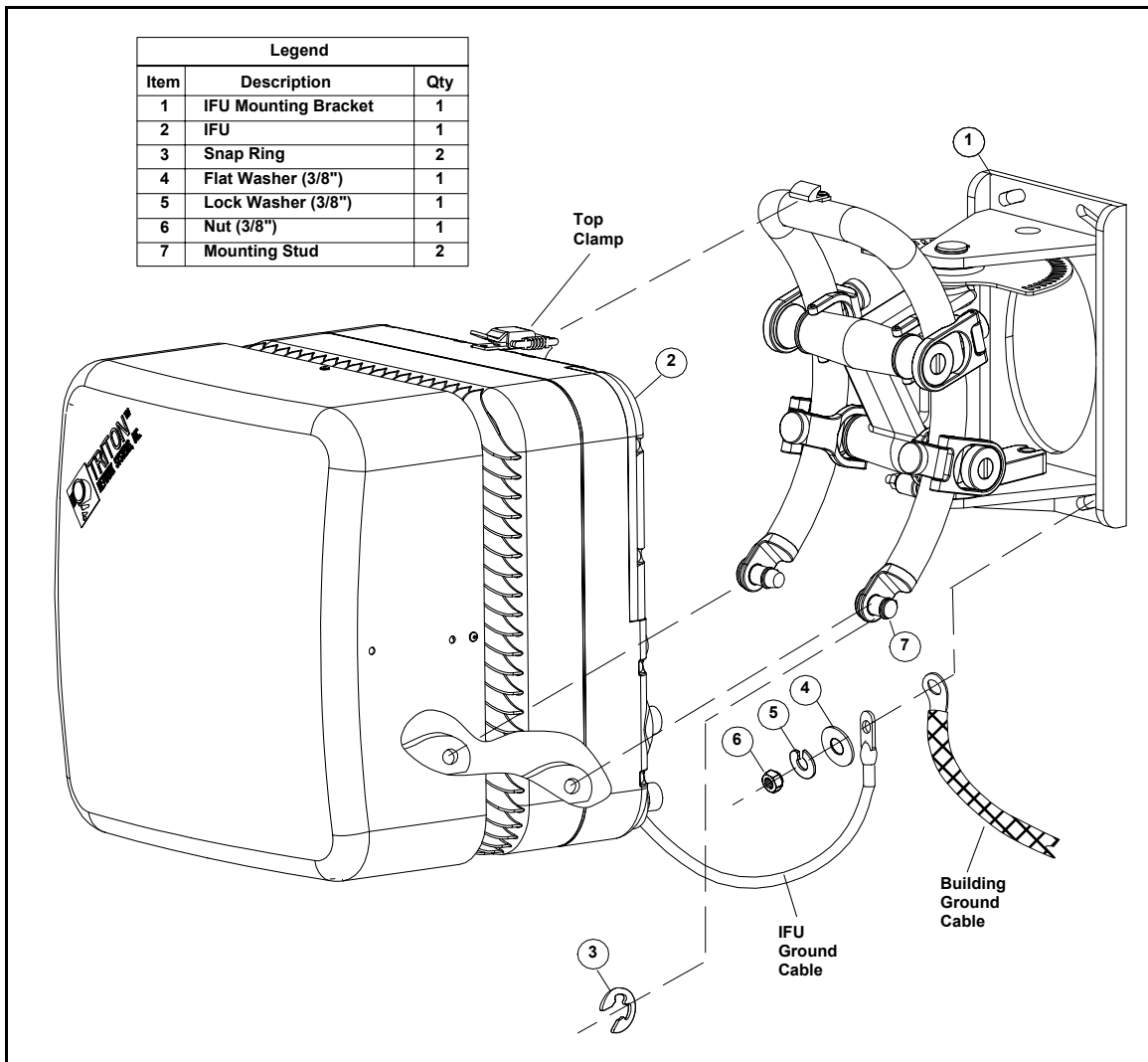

**Figure 5-2.** IFU Removal

- 4 To install a new IFU, see *Installing an IFU* on page 3-22 and *Attaching IFU Cables* on page 3-25.

## Packing an IFU for Shipment

Use the original packing material to ship the IFU to the factory. If packing material is not available, contact Triton Network Systems (see *Contacting Triton Network Systems, Inc.* on page xiii).

► **To package an IFU for shipment:**

- 1 Make sure the following packaging materials are present:
  - Delivery box
  - Protective base
  - Radome protector sleeve
  - Protective covers

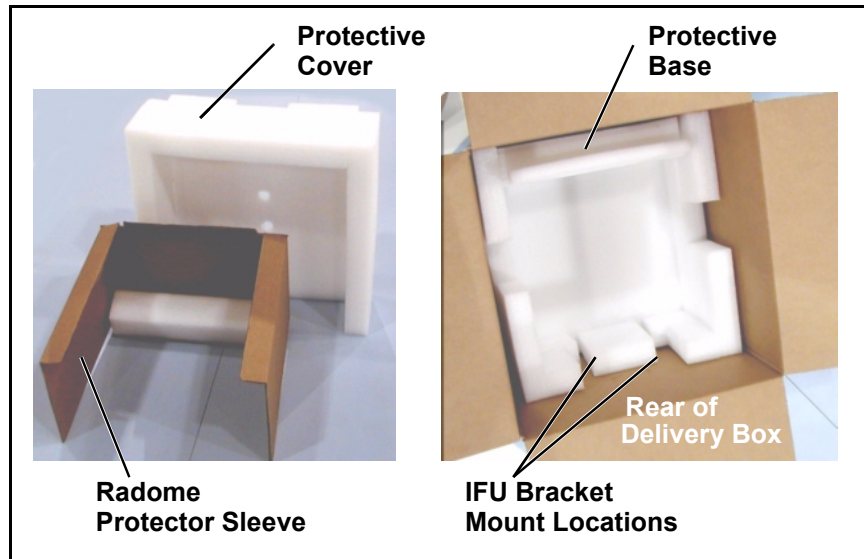

**Figure 5-3.** IFU Packaging Materials

- 2 Place protective covers over the optical fiber and power connectors and position the alarm cable as shown in Figure 5-4.

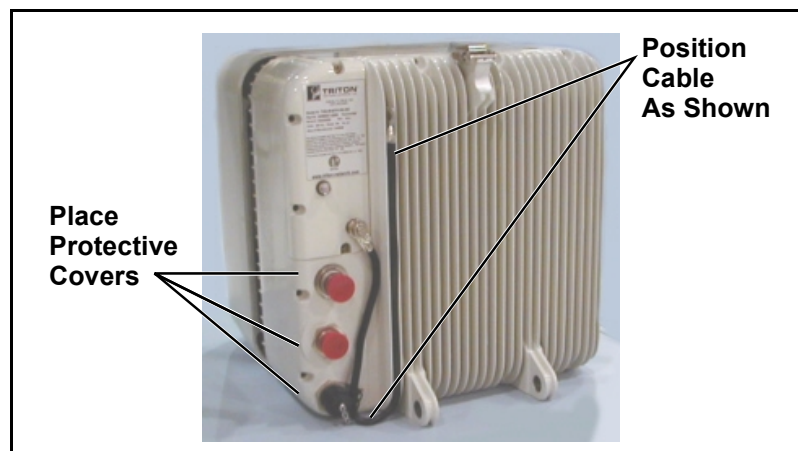
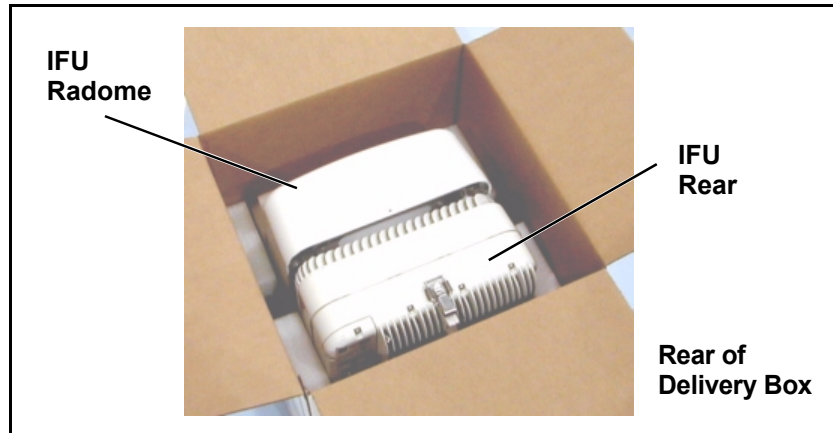

**Figure 5-4.** IFU Preparation



- 3 Lower the IFU into the box in which the IFU was delivered. Make sure the protective base is placed at the bottom of the box and the IFU bracket mount locations are aligned securely within the spaces provided.

**NOTE:** Do not pick up the IFU by grasping the top of the radome cover. Using both hands, grasp the IFU on either side of the IFU rear and gently lower the IFU into the delivery box.



**Figure 5-5.** Positioning the IFU

- 4 Insert the radome protector sleeve in the spaces provided on both sides of the radome. The protective cardboard flap fits between the radome and the rear of the IFU. The protective styrofoam flap fits between the radome and the front of the box.

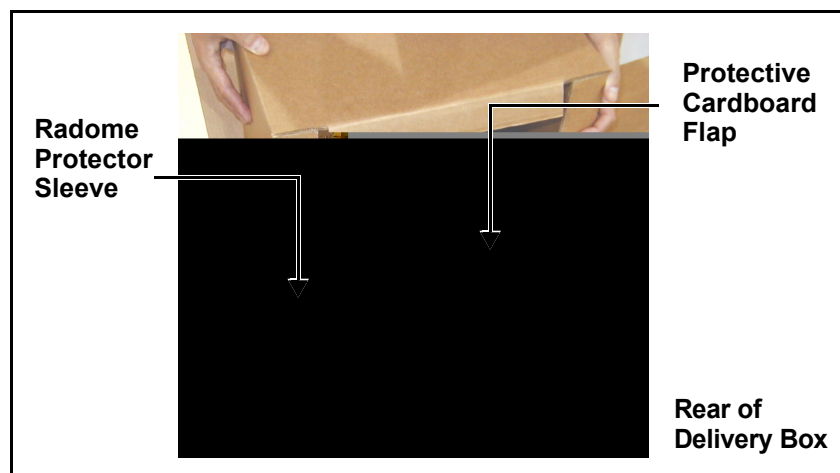

**Figure 5-6.** Inserting the Radome Protector Sleeve

- 5 Position the protective cover by inserting the styrofoam edges around the back and sides of the IFU as shown below.

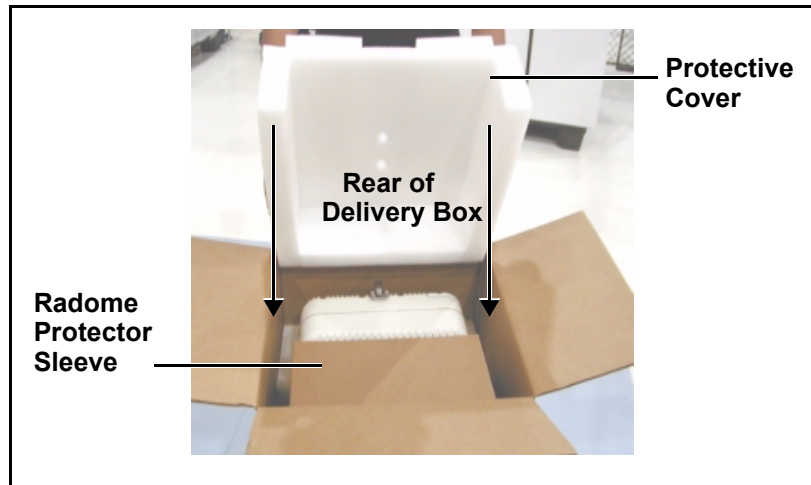

**Figure 5-7.** Placing the Protective Cover

- 6 Complete packing the IFU by securing the delivery box. Secure the box by folding in the box flaps and taping the flaps together.

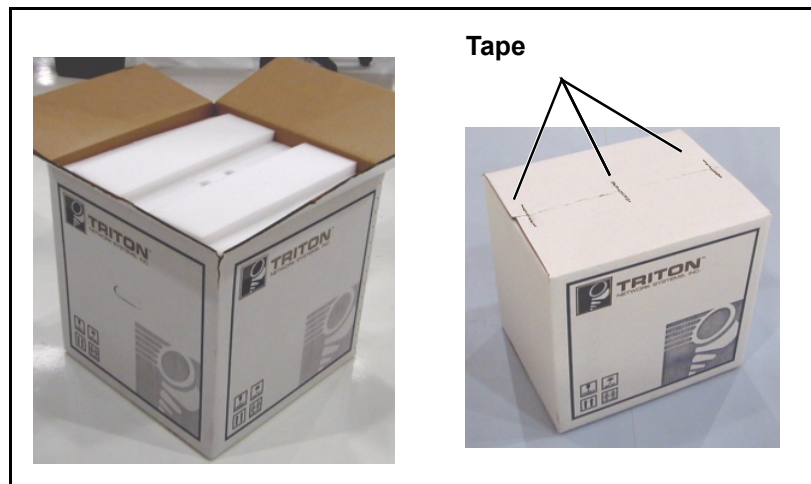

**Figure 5-8.** Securing the Delivery Box



# *IFU Test Results*

This appendix contains tables for recording the power, fiber optic, and alignment test data. This appendix includes the following tables:

- Table A-1 shows the results of the Power Source Test.
- Table A-2 shows the results of the Alarm Cable Verification Test.
- Table A-3 shows the results of the Fiber Optic Test.
- Table A-4 shows the results of Alignment Test.

## Power Source Test

**Table A-1.** Power Supply Test Results

Pins	Results	Pass Criteria	Pass/Fail
IFU Alpha - A & C		- 46 Vdc to - 56 Vdc	
IFU Alpha - B & H		- 46 Vdc to - 56 Vdc	
IFU Beta - A & C		- 46 Vdc to - 56 Vdc	
IFU Beta - B & H		- 46 Vdc to - 56 Vdc	
IFU Gamma - A & C		- 46 Vdc to - 56 Vdc	
IFU Gamma - B & H		- 46 Vdc to - 56 Vdc	

## SONET OC-3 Fiber Optic Test

**Table A-2.** SONET OC-3 Fiber Optic Test Results

IFU Alpha Test Adapter End	Fiber Signal Strength >- 5.0 dBm @ 1310 nm	IFU Beta Test Adapter End
IFU Alpha Interconnect TX		IFU Beta Interconnect RX
IFU Alpha Interconnect RX		IFU Beta Interconnect TX

## Far-End Test

**Table A-3.** Far-End Test Results #1

IFU Number	Min/Max Signal Strength	IFU Signal Strength Set	Pass/Fail

**Table A-4.** Far-End Test Results #2

IFU Number	Min/Max Signal Strength		IFU Signal Strength Set	Pass/Fail

## Near-End Test

**Table A-5.** Near-End Test Results #1

IFU Number	Min/Max Signal Strength		IFU Signal Strength Set	Pass/Fail

**Table A-6.** Near-End Test Results #2

IFU Number	Min/Max Signal Strength		IFU Signal Strength Set	Pass/Fail





# *Invisible Fiber™ Product Glossary*

## **10BaseFL**

Part of the IEEE 802.1j standard for 10 Mbps Ethernet fiber.

## **10BaseT**

IEEE 802.3 standard specifying Ethernet over unshielded twisted pair cables.

## **99.999% availability**

(Also known as five 9s availability.) Amount of time the system is expected to be available. If the system is available 99.999% of the time, expected down time is approximately six minutes per year, derived as follows:

$$\begin{aligned} \text{Days per year} \times \text{hours per day} \times (100 - 99.999) \div 100 \times 60 = \\ 365.25 \times 24 \times (100 - 99.999) \div 100 \times 60 = 5.2 \text{ minutes} \end{aligned}$$

## **100BaseFX**

Part of the IEEE 802.3u standard for 100 Mbps Ethernet over fiber.

## **A**

### **ABAM**

A designation of Lucent Technologies for 22 gauge, 110 ohm, insulated, twisted-pair cable used to connect an ADM switch to a T1 distribution panel.

---

## Add/Drop Multiplexer (ADM)

A device that provides an interface between the different signals in a digital T-carrier or SONET network. When an ADM is inserted in a transmission line, it enables lower rate signals to be extracted (dropped) and transported differently (electrical or optical). Similarly, a lower rate signal can be inserted (added) into a higher rate signal.

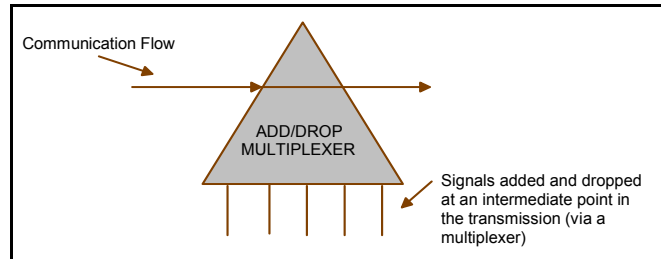

## ADM

See *Add/Drop Multiplexer (ADM)*.

## AIS

See *Alarm Indication Signal (AIS)*.

## Alarm Indication Signal (AIS)

A special signal that is transmitted to downstream equipment for specific equipment fault conditions.

## antenna

A mechanical device that can convert electrical signals to and from electromagnetic waves. An IFU contains an antenna.

## Asynchronous Transfer Mode (ATM)

A cell-based protocol, developed by the ITU-T, for transmitting and switching voice, video, and data traffic. ATM technology does not use a fixed timing reference, hence the name asynchronous.

## ATM

See *Asynchronous Transfer Mode (ATM)*.

## atmospheric absorption

Amount of energy lost when radio waves are transmitted due to the presence of atmospheric gases.

## attenuation

The reduction in the strength of a signal measured in dB. See also *propagation loss*.



---

**azimuth**

The horizontal angle the radiating lobe of an antenna makes. When you adjust an IFU by its azimuth, you move it on its horizontal plane (left to right or right to left).

**B****backbone**

A backbone is the transport path that provides connectivity to other paths. On the Internet or a WAN, the backbone is a series of paths to which local, regional, or global networks connect.

**backhaul**

A transmission path used to move traffic to/from a remote location from/to a central location. (The verb form is *back haul*.)

**bandwidth**

The range of frequencies over which a signal is transmitted.

**BER**

See *Bit Error Rate (BER)*.

**Bit Error Rate (BER)**

The number of bit errors detected – displayed as the ratio of the average number of errored bits in a given number of bits sent. The BER is used to measure transmission quality. For example, a BER of  $10^{-12}$  is equivalent to one error in a trillion bits, which means that for:

- SONET OC-3, one error bit is detected approximately every 1.8 hours.
- Fast Ethernet, one error bit is detected approximately every 2.8 hours.

**BNC connector**

Bayonet Neil-Concelman connector. A bayonet type of connector for coaxial cables in an Ethernet network.

**C****Central Office (CO)**

Location at which one or more switches reside for aggregating voice or data traffic.

**Central Processing Unit (CPU)**

Central controller that coordinates functions in the IFU.

---

**channel**

Physical medium through which signals are transmitted. In optical fiber transmissions, a channel is a separate wavelength of light within a combined multiplexed light stream.

**channelization**

Logically subdividing a frequency (normally assigned by a regulatory agency for the delivery of broadband wireless services).

**CLEC**

See *Competitive Local Exchange Carrier (CLEC)*.

**CO**

See *Central Office (CO)*.

**co-channel interference**

Interference between signals transmitted within one radio frequency channel.

**colocation**

Space set aside for a customer's telecommunications equipment on the service provider's premises. For example, a web site owner could place its computer server on the premises of an ISP, or an ISP could locate its network router at a company that supplies switching services to other ISPs.

**Competitive Local Exchange Carrier (CLEC)**

Independent company that competes with the already established local telephone company by providing its own network and switching. CLEC distinguishes a new or potential competitor from an established local exchange carrier (LEC). The term originated from the Telecommunications Act of 1996, which was intended to promote competition among long-distance and local phone service providers.

**commissioning**

Tasks required to enable equipment to be placed in a live network. IFU commissioning tasks include configuration and antenna alignment.

**configuration management**

The process of setting equipment attributes that enables equipment to function as intended.

**consecutive point**

Network architecture implemented via a point-to-point-to-point design.

**CPE**

See *Customer Premise Equipment (CPE)*.

---

**CPU**

See *Central Processing Unit (CPU)*.

**Crane rain model**

System of formulas, charts, and maps developed by Robert K. Crane to depict a global prediction of attenuation caused by rain. See also *rain attenuation*.

**Customer Premise Equipment (CPE)**

Equipment (such as telephones and computers) installed at a customer's office.

**customer site**

Network equipment configuration for a location at which network access is provided in a carrier's consecutive point network.

**D****dB**

See *decibel (dB)*.

**decibel (dB)**

The unit of measurement for signal strength, usually the ratio between a transmitted signal and a standard signal source.

**demarcation point**

Logical dividing point between equipment and a network.

**DNS**

See *Domain Name System (DNS)*.

**domain name**

Name that identifies one or more IP addresses. For example, *triton-network.com* is a domain name.

**Domain Name System (DNS)**

A utility that translates an IP address into a domain name and vice versa. For example: *triton-network.com* translates to *208.206.40.131*.

**E****Element Management System (EMS)**

Software application used to manage network equipment.

**EMS**

See *Element Management System (EMS)*.

---

**Ethernet**

Generic term for the IEEE 802.3 standard network transmission protocol.

**exciter**

An oscillator that enables a tuner to change its frequency.

**F****fade margin**

Amount of signal reduction a receiver can tolerate and continue to maintain satisfactory performance.

**far-end IFU**

- a) IFU at the other end of the link in the network (during site evaluation).
  - b) Second IFU installed in a linked pair of IFUs.
- See also *near-end IFU*.

**Fast Ethernet**

Generic term for a IEEE standard network 100 Mbps transmission protocol.

**fault management**

Software that reports and identifies the source of network faults.

**fiber optics**

Technology in which information is transmitted as light impulses from one point to another through extremely thin glass or plastic wire or fiber.

**fixed wireless system**

Communication system that uses radio spectrum to provide services to locations that are not mobile.

**forward error correction**

A system in which redundant information is generated at the transmitted end so that the receiving unit can detect, locate, and correct any errors before delivering the transmission.

**free space propagation loss**

Normal signal attenuation of radio waves transmitted through free space. Free space loss increases logarithmically with increased hop distance.

---

### **Fresnel zone**

A diffraction zone around the line-of-sight path between two points as shown in the following illustration.

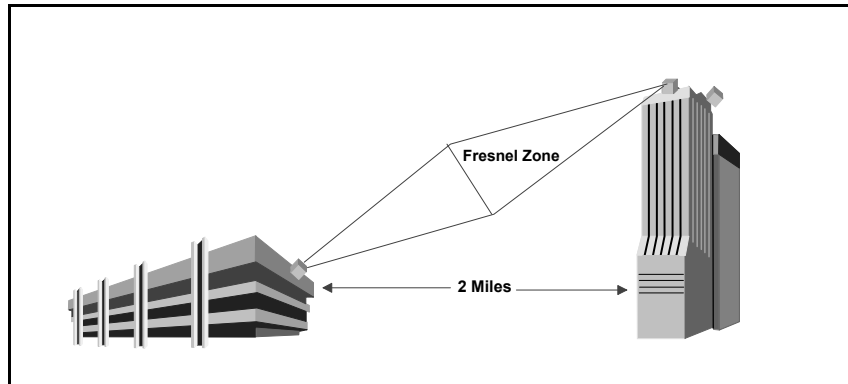

The line of sight, including the Fresnel zone, must be clear of obstructions to ensure communication between the IFUs.

## **G**

### **gateway**

A network point that aggregates traffic and acts as an entrance to another network.

### **gateway site**

Network equipment configuration for a location that aggregates customer traffic in a consecutive point network for access to and from the Internet.

### **general purpose input (GPI)**

The input ports on the IFU provide external control of equipment or detection of external alarms. Each IFU contains two GPI ports.

### **GPI**

See *general purpose input (GPI)*.

## **H**

### **histogram**

A graphical representation of the distribution of a performance parameter.

### **hop distance**

The distance between two communicating IFUs. One objective in network design is to design link hop distances so that the RF path loss does not exceed the path loss allowance for the required availability or grade of service.

---

## **HP OpenView™**

Hewlett Packard's network management product consisting of a suite of software tools that enable network operations staff to manage the elements in a network. HP OpenView Network Node Manager™ and the IFU Link Manager software provide complete element management functions for an IFU network.

## **hub**

A location in a network where data is aggregated and forwarded to its destination. A hub contains a switch and a router.

# I

## **IFU**

Invisible Fiber™ unit. Outdoor fixed-wireless device, designed to fiber-optic specifications, that combines antenna, transceiver, modem, and controller modules to transport high-bandwidth network-grade broadband telephony and data services.

## **IFU Link Manager**

Triton Network Systems' software application that provides fault, performance, configuration, and security management functions, enabling onsite technicians and network management staff to configure and monitor IFUs.

## **ILEC**

See *Incumbent Local Exchange Carrier (ILEC)*.

## **Incumbent Local Exchange Carrier (ILEC)**

A generic term for the Regional Bell Operating Company (RBOC) or local carrier that was providing local telephone service when the Telecommunications Act of 1996 was enacted.

## **indoor repeater site**

Location used to extend a consecutive point network to enable future customer access.

## **interconnect**

A circuit administration point that provides capability for routing and re-routing circuits.

## **Internet Protocol (IP)**

A connectionless network layer protocol used for forwarding individual packets from one intermediate destination (typically a router) to another on the way to their final destination.

---

**Internet Service Provider (ISP)**

An operator that provides its customers access to the Internet.

**Invisible Fiber™ unit**

See *IFU*.

**IP**

See *Internet Protocol (IP)*.

**ISP**

See *Internet Service Provider (ISP)*.

**ITU rain model**

System of formulas, charts, and maps developed by the International Telecommunication Union (ITU) to characterize rain attenuation.

**J****Java™**

A C++-like, object-oriented programming language, created by Sun Microsystems and used to build client and server applications that run on any hardware platform where a Java virtual machine resides.

**Java™ Runtime Environment (JRE)**

Software platform that enables Java applications to execute. The IFU Link Manager software requires JRE.

**JRE**

See *Java™ Runtime Environment (JRE)*.

**Java™ virtual machine**

Software, created for specific hardware platforms (microprocessors), that interprets compiled Java code (bytecode) using the microprocessor's set of instructions. Java virtual machines enable any Java application (bytecode) to run on any platform without requiring the programmer to rewrite or recompile the application for each platform.

**L****LAN**

See *Local Area Network (LAN)*.

**line of sight**

Straight line of space between a transmitter and receiver. The space between a transmitter and receiver must be clear of obstructions because the transmission media (such as microwave, infrared, and laser) travel in a perfectly straight line.

---

**link angles**

GPS (Global Positioning System) coordinates of the angle for an IFU linked pair.

**link budget**

The sum of transmission gains and losses between transmitter and receiver. The total should be equal to or less than the system gain. The link budget is configured using the transmitted signal power, receiver sensitivity, and antenna gains.

**link manager**

See *IFU Link Manager*.

**LMDS**

See *Local Multipoint Distribution Service (LMDS)*.

**Local Area Network (LAN)**

An integrated data communication network (linking computers and peripheral devices) designed to provide services to a closed user community. See also *MAN* and *WAN*.

**Local Multipoint Distribution Service (LMDS)**

Broadband wireless spectrum over which telephony and data services are delivered.

**loop back**

Directing signals back toward the transmitting device at some point along the communications path. Used as a method for troubleshooting.

**M****MAN**

Metropolitan Area Network. Integrated data communication network within a city. See also *LAN* and *MAN*.

**Management Information Base (MIB)**

A collection of statistics and variables residing on an SNMP-managed device. The statistics allow collection of performance data and the variables allow configuration of the device.

**MIB**

See *Management Information Base (MIB)*.

**microwave radio**

Device that uses microwave frequencies (3–300 GHz) for consecutive point communication.



---

**Millimeter Wave (MMW)**

The frequency range between 30 and 300 GHz.

**MMIC**

See *Monolithic Microwave Integrated Circuit (MMIC)*.

**MMW**

See *Millimeter Wave (MMW)*.

**modem**

MOdulator, DEModulator. A device that converts between analog and digital signaling.

**modulation**

Act of encoding information onto a carrier signal.

**Monolithic Microwave Integrated Circuit (MMIC)**

Integrated circuit technology that provides two-watt linear power at the Tx port of the RF power amplifier.

**multi-mode fiber**

Optical fiber designed to carry multiple carrier signals concurrently, each at a slightly different reflection angle within core of the optical fiber. See also *single-mode fiber*.

**multiplexer**

Device that aggregates traffic into a single medium.

**N****NE**

See *Network Element (NE)*.

**near-end IFU**

- a) IFU at the location being evaluated.
  - b) First IFU installed in a linked pair of IFUs.
- See also *far-end IFU*.

**net mask**

A filter used to determine the portion of a network an IP address belongs to. Using *208.206.40.131* as an example:

- *208.206* identifies the class B network
- *40.131* identifies a host on this network.

**Network Element (NE)**

Single piece of equipment in the network.

---

**Network Interface Card (NIC)**

Interface between physical transmitter layer and modem.

**network management**

The policies, procedures, and tools that enable an operator to monitor and manage network elements.

**Network Management System (NMS)**

Integrated, comprehensive system of equipment used for monitoring and managing network elements.

**Network Operations Center (NOC)**

Location at which monitoring and management of a network might take place.

**network provisioning**

Act of configuring IFU network hardware and software to make the network operational.

**NIC**

See *Network Interface Card (NIC)*.

**NMS**

See *Network Management System (NMS)*.

**NOC**

See *Network Operations Center (NOC)*.

**Not REPorting (NREP)**

Condition indicated from the Network Monitor which is triggered when more than 135 seconds elapse without status information being received by the Network Monitor from a particular IFU.

**NREP**

See *Not REPorting (NREP)*.

**O****OAM&P**

Operations, Administration, Maintenance, and Provisioning. Describes a piece of equipment or personnel required to manage a network.

**OC-3**

Optical Carrier level 3. Optical signal designed to receive and transmit SONET. A pure OC-3 SONET channel carries 155.52 Mbps.

---

**OC-12**

Optical Carrier level 12. Optical signal designed to receive and transmit SONET. A pure OC-12 SONET channel carries 622.08 Mbps.

**OC-48**

Optical Carrier level 48. Optical signal designed to receive and transmit SONET. A pure OC-48 SONET channel carries 2.4 Gbps.

**operating system (OS)**

Program that loads when a computer is booted and manages all the other applications in the computer.

**OS**

See *Operating System (OS)*.

**outdoor repeater site**

Location used to extend a consecutive point network.

**P****password**

A string of characters entered by a user, typically in a Login window, to gain access to a computer system.

**path loss allowance**

The net amount of amplification given to the signal in an IFU link, including margins for adequate received SNR and channel fading. In other words, path loss allowance is equal to the system gain plus the antenna gains.

**payload**

User traffic transported over a network

**Point Of Presence (POP)**

Umbrella name referring to the location of the physical access point where user traffic is aggregated.

**polarization**

Directional orientation of a radio wave electric field. Some radio communication systems can exploit polarization differences to reduce interference from nearby links.

**POP**

See *Point Of Presence (POP)*.

**power source**

A separate unit or part of a circuit that supplies power to the rest of the circuit or to a system.

---

**propagation loss**

Signal attenuation that occurs during transmission.

**provisioning**

Act of configuring the gateway routers and the site equipment to enable a customer to receive service.

**Q****QAM**

Quadrature Amplitude Modulation. Transmitted signal defined by amplitude and phase.

**R****Radio Frequency (RF)**

An electromagnetic wave frequency from approximately 3 KHz to approximately 300 GHz. Includes the frequencies used for radio and television transmission.

**radio overhead**

IFU communication channel in addition to the payload.

**rain attenuation**

Transmit signal loss due to rain.

**Received Signal Strength Indicator (RSSI)**

Received Signal Strength Indicator (also known as RSL, Received Signal Level). A measured value from a receiver describing the received signal level or strength.

**receiver**

Telecommunication equipment device that captures and converts a transmitted signal to the required format.

**reference oscillator**

A device that generates a precise radio frequency signal to be used as a reference.

**RF**

See *Radio Frequency (RF)*.

**RF spectrum**

Range of available radio frequencies.

---

**router**

A layer-3 physical device that aggregates and directs network traffic based on TCP/IP.

**RS-232**

Recommended standard physical interface (connector) for electrical, functional, and mechanical communication interfaces between computers, terminals, and modems.

**RSL**

See *Received Signal Strength Indicator (RSSI)*.

**RSSI**

See *Received Signal Strength Indicator (RSSI)*.

**S****security management**

System to protect a network from invalid access.

**Signal Quality Metric (SQM)**

Ratio of bit energy to noise power spectral density. The SQM value relates to transmission and receiver signal quality.

**Simple Network Management Protocol (SNMP)**

Industry standard protocol used to communicate between elements and management systems in a network.

**single-mode fiber**

Optical fiber that allows only a single ray of light to propagate as a carrier. See also *multi-mode fiber*.

**site drawing**

Graphic depiction, which shows the location of all IFU-related components drawn by a contractor and designee. A site drawing is a component of a site engineering folder.

**site engineering folder**

Documentation based on the information gathered during the site survey and product requirement specifications.

**SNMP**

See *Simple Network Management Protocol (SNMP)*.

**SONET**

See *Synchronous Optical NETWORK (SONET)*.

---

**SNR**

Signal-to-Noise Ratio. The SNR measures the quality of the intended signal versus any background noise. Usually expressed in decibels (dB).

**SQM**

See *Signal Quality Metric (SQM)*.

**staging**

Installation phase during which equipment might be integrated and made ready for deployment.

**subnet mask**

See *net mask*.

**switch**

A network device that selects the path for sending traffic to its next destination.

**Synchronous Optical Network (SONET)**

Standard protocol that defines a group of fiber-optic transmission rates that can transmit various bit-rate signals inside a broadband synchronous signal. SONET was designed to allow for a multi-vendor environment.

**system gain**

The ratio of transmit power to receiver sensitivity, usually expressed in dB. This ratio usually does not include antenna gain.

**T****TCM**

See *Trellis Coded Modulation (TCM)*.

**TCP/IP**

See *Transmission Control Protocol/Internet Protocol (TCP/IP)*.

**Transmission Control Protocol/Internet Protocol (TCP/IP)**

Family of data communication protocols universally implemented on the Internet. TCP is a transport layer protocol used for reliable, connection-oriented communication between two applications.

**transceiver**

Abbreviation for a transmitter and receiver.

**transmitter**

Device that converts signals for transmission.

---

**Trellis Coded Modulation (TCM)**

The goal of TCM is the same as other error correction schemes – to increase data rate by adding redundancy to reduce error. TCM uses redundancy to enhance the signal detection process.

**Trellis encoding rate**

Rate of TCM. (See *Trellis Coded Modulation (TCM)*.)

**Tx**

Transmitted signal or transmitter.

**V****Virtual Private Network (VPN)**

Private network that is built on top of a public network.

**VPN**

See *Virtual Private Network (VPN)*.

**W****WAN**

See *Wide Area Network (WAN)*.

**Wide Area Network (WAN)**

High-speed network that connects networks over a large geographical area. (See also *LAN* and *MAN*.)

---





# Index

## A

- aligning
  - near-end IFU 4-3

## B

- bracket
  - attached to wall 3-7
  - mounting 3-7
  - pole mount 3-8
  - removing IFU from 5-4

## C

- cable 1-2
  - connections 3-25
  - fiber optic 1-2
    - continuity test 3-18–3-21, 3-22
  - power 1-2
    - input test 3-11
    - input test results form A-2
    - verify connection 2-4–2-5
  - removing 5-2
  - verify connection
    - setup 2-4
- cautions
  - personal injury xvii
    - convention xv
  - service interruption xviii
    - convention xv
- cleaning
  - fiber optic cable
    - procedure 3-19
- commissioning
  - setup 4-2
- commissioning tools 4-2

## components

- fiber optic cable, installing 3-13
- IFU bracket, mounting 3-7
- power cables, installing 3-9

## configuration 2-1

- defined 2-1
- parts list 2-1
- procedure 2-2
- setup 2-6
- staging area 2-1

contacting Triton Network Systems, Inc. xiii

## conventions

### warnings and safety

- English xv
- fiber optic warning xv
- French xxi
- risk of electrical shock xv
- risk of personal injury xv
- risk of radio frequency energy exposure
  - xv
- risk of service interruption xv

## D

### danger

- fiber optics xvi
- high current hazard xvi
- high voltage hazard xvi
- demarcation jumper cables 3-17
- demarcation panel
  - connections 3-15

## E

- earth ground 1-3

---

electrical shock warnings xvi  
convention xv  
engineering folder 1-1

## **F**

far-end IFU  
defined 3-22  
test 4-10  
results form A-2  
FCC RF safety requirement 3-7  
fiber optic cable 1-2  
cleaning procedure 3-19  
continuity test 3-18–3-21, 3-22  
installing 3-13  
testing procedure 3-21  
fiber optic warnings xvi  
convention xv

## **G**

grounding system  
earth ground 1-3

## **I**

IFU  
aligning near-end 4-3  
bracket  
*See* bracket  
commissioning  
far-end 4-7  
far-end test 4-10  
far-end test results form A-2  
near-end test results form A-3  
determining mounting location 3-5  
FCC RF safety 3-7  
installing 3-22  
mounting 3-24  
part number 2-2  
pole setup 3-8  
power termination  
wiring diagram 3-11  
removing from bracket 5-4  
requirement for mounting on roof  
pole mount 3-5  
wall mount 3-5  
servicing 5-2  
wall mount setup 3-7

IFU Link Manager  
defined 1-2  
for commissioning 4-2  
installation  
attaching cables to IFU 3-25  
cable requirements 1-2  
fiber optic cable 3-13  
IFU 3-22  
IFU components 3-3  
fiber optic cable 3-13  
power cable 3-9  
overview 1-1  
power cables 3-9  
power source requirements 1-2  
setup 3-2

## **J**

jumper  
demarcation box connections 3-17  
jumper cables  
demarcation 3-17

## **L**

lifting guideline 2-3

## **M**

maintenance 5-2  
mises en garde xxv  
mounting  
IFU 3-24  
IFU bracket 3-7  
IFU requirements  
pole mount 3-5  
wall mount 3-5

## **N**

National Electrical Code (NEC) 1-3  
near-end IFU  
aligning 4-3  
defined 3-22  
test 4-10  
results form A-3

---

## O

optical fiber  
    *See* fiber optic

## P

part number 2-2  
parts list  
    configuration 2-1  
    site installation 3-2  
personal injury  
    cautions xvii  
    electrical shock warnings xvi  
    fiber optics warnings xvi  
pole mount 3-8  
pole mount IFU 3-5  
power cable 1-2  
    hookup 2-4  
    IFU power termination  
        wiring diagram 3-11  
    installing 3-9  
    test 3-11  
        results form A-2  
    verify connection 2-4–2-5  
    wiring diagram 3-10  
power source 1-2  
precautions xix  
procedure  
    aligning near-end IFU 4-3  
    configuration 2-2  
    determining IFU mounting location 3-5  
    fiber optic cable  
        cleaning 3-19  
        testing 3-21  
    installing fiber optic cable 3-13  
        cleaning 3-19  
        testing 3-21  
    installing power cables 3-9  
    mounting IFU bracket 3-7  
    removing cables 5-2  
    removing IFU from bracket 5-4

## R

radio frequency  
    energy exposure  
        convention xv  
        warnings xvi

removing  
    IFU cables 5-2  
    IFU from bracket 5-4  
risk  
    electrical shock  
        convention xv  
        warnings xvi  
    fiber optics  
        convention xv  
        warnings xvi  
    other precautions xix  
    personal injury  
        cautions xvii  
        convention xv  
    radio frequency energy exposure  
        convention xv  
        warnings xvi  
    service interruption  
        cautions xviii  
        convention xv  
risque  
    câbles à fibres optiques xxii  
        convention xxi  
    d'interruption de service xxiv  
        convention xxi  
    de lésions corporelles xxiii  
        convention xxi  
    décharge électrique xxii  
        convention xxi  
    l'exposition de l'énergie radiofréquences  
        xxiii  
        convention xxi  
roof requirements  
    FCC RF safety 3-7  
    IFU mounting requirements  
        pole mount 3-5  
        wall mount 3-5

## S

safety requirement, FCC RF 3-7  
service 5-2  
setup  
    commissioning IFUs 4-2  
    configuration 2-6  
    installing IFUs 3-2  
    pole mounted bracket 3-8  
    verify connection 2-4  
    wall mounted bracket 3-7  
site engineering folder 1-1

---

- site installation
  - parts list 3-2
  - tools 3-2
- staging
  - See* configuration
- surge suppression 1-3
  - defined 1-3

## T

- test
  - far-end IFU 4-10
    - results form A-2
  - fiber optic continuity 3-18–3-21, 3-22
  - near-end IFU 4-10
    - results form A-3
  - power cable 3-11
    - results form A-2
  - power cable connection 2-4–2-5
- testing
  - fiber optic cable
    - procedure 3-21
- tools
  - commissioning 4-2
  - site installation 3-2
- Typical SONET OC-3 3-17

## W

- wall mount 3-7
- wall mount, IFU 3-5
- warnings
  - risk from fiber optics xvi
    - convention xv
  - risk of electrical shock xvi
    - convention xv
  - risk of radio frequency energy exposure xvi
    - convention xv