



## Owner's Manual

---

# ECONO-HORSE™ 7HP Model Tiller

- Safety
- Assembly
- Controls
- Operation
- Maintenance

Model

---

12185

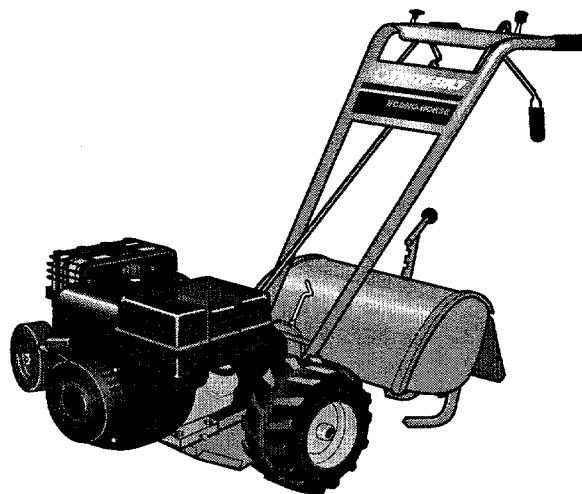

Dear Owner:

You now own one of the finest rear-tine rototillers available. Your new tiller allows you to till and cultivate your garden with ease, and accomplish dozens of other property management projects as well. Your tiller is famous for its ruggedness, performance and high-quality engineering. We know you'll enjoy using it.

Please carefully read this Manual. It tells you how to safely and easily assemble, operate and maintain your machine. *Be sure that you and any other operators carefully follow the recommended safety practices at all times. Failure to do so could result in personal injury or property damage.*

Of course, if you should ever have any problems or questions, please contact your local authorized service dealer or call the Factory (see back cover).

We want to be sure that you are completely satisfied at all times.

---

## See Back Cover for Customer Service information

---

### Safety Alert Symbol



This is a **safety alert symbol**. It is used in this manual and on the unit to alert you to potential hazards. When you see this symbol, read and **obey** the message that follows it. Failure to obey safety messages could result in personal injury or property damage.



This machine meets voluntary safety standard B71.8 – 1996, which is sponsored by the Outdoor Power Equipment Institute, Inc., and is published by the American National Standards Institute.

## **WARNING**

**The engine exhaust from this product contains chemicals known to the State of California to cause cancer, birth defects or other reproductive harm.**

## Table of Contents

|   |                   |
|---|-------------------|
| <b>SECTION 1: SAFETY</b> .....                              | <b>3</b>          |
| Safety Decals .....   | 5                 |
| <b>SECTION 2: ASSEMBLY</b> .....                            | <b>6</b>          |
| Attach Handlebars .....                                     | 7                 |
| Attach Maneuvering Clutch Lever .....                       | 7                 |
| Attach Forward Clutch Rod .....                             | 8                 |
| Check Transmission Gear Oil Level .....                     | 8                 |
| Add Motor Oil to Engine .....                               | 9                 |
| Attach Engine Throttle Lever .....                          | 9                 |
| Attach Wheel Gear Lever .....                               | 10                |
| Check Air Pressure in Tires .....                           | 10                |
| Check Hardware for Tightness .....                          | 10                |
| <b>SECTION 3: FEATURES &amp; CONTROLS</b> .....             | <b>11</b>         |
| Wheel Gear Lever .....                                      | 11                |
| Forward Clutch .....  | 11                |
| Maneuvering Clutch .....                                    | 12                |
| Depth Regulator .....                                       | 12                |
| Handlebar Height Adjustment .....                           | 12                |
| Engine Throttle Lever .....                                 | 13                |
| Recoil Starter .....  | 13                |
| <b>SECTION 4: OPERATION</b> .....                           | <b>14</b>         |
| Starting and Stopping the Engine .....                      | 14                |
| Operating the Tiller .....                                  | 15                |
| Tilling Tips & Techniques .....                             | 17                |
| Power Composting .....                                      | 19                |
| Loading and Unloading the Tiller .....                      | 19                |
| Changing Belt Range Speeds .....                            | 20                |
| <b>SECTION 5: MAINTENANCE</b> .....                         | <b>21</b>         |
| Required Maintenance Schedule .....                         | 21                |
| Tiller Lubrication .....                                    | 22                |
| Check for Oil Leaks .....                                   | 22                |
| Check Hardware .....  | 22                |
| Transmission Gear Oil Service .....                         | 23                |
| Engine Oil Service .....                                    | 23                |
| Air Cleaner Service .....                                   | 23                |
| Spark Plug Service .....                                    | 24                |
| Spark Arrester Screen Service .....                         | 24                |
| Engine Cleaning .....                                       | 24                |
| Carburetor/Governor Control Adjustments .....               | 24                |
| Throttle Control Adjustment .....                           | 24                |
| Wheel Gear Cable Adjustment .....                           | 24                |
| Off Season Storage .....                                    | 24                |
| Bolo Tines .....  | 25                |
| Checking and Adjusting the Tension on the Drive Belts ..... | 26                |
| Forward Drive Belt Removal and Installation .....           | 28                |
| Reverse Drive Belt Removal and Installation .....           | 29                |
| <b>Troubleshooting</b> .....                                | <b>30</b>         |
| <b>Tiller Specifications/Attachments</b> .....              | <b>31</b>         |
| <b>Customer Service Information</b> .....                   | <b>Back Cover</b> |

# Section 1 Safety

## SPARK ARRESTER WARNING TO RESIDENTS OF CALIFORNIA AND SEVERAL OTHER STATES

Under California law, and under the laws of several other states, you are not permitted to operate an internal combustion engine using hydrocarbon fuels on any forest, brush, hay, grain, or grass covered land; or land covered by any flammable agricultural crop without an engine spark arrester in continuous effective working order.

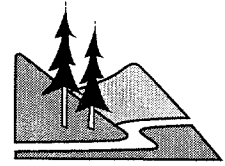

The engine on the unit is an internal combustion engine which burns gasoline, a hydrocarbon fuel, and must be equipped with a spark arrester muffler in continuous effective working order. The spark arrester must be attached to the engine exhaust system in such a manner that flames or heat from the system will not ignite flammable material. Failure of the owner/operator of the unit to comply with this regulation is a misdemeanor under California law (and other states) and may also be a violation of other state and/or federal regulations, laws, ordinances or codes. Contact your local fire marshal or forest service for specific information about which regulations apply in your area.

### Training

1. Carefully read this Owner's Manual, the separate Engine Owner's



Manual, and any other literature you may receive. Be thoroughly familiar with the controls and the proper use of the tiller and its engine. Know how to stop the unit and disengage the controls quickly.

2. Never allow children to operate the tiller. Never allow adults to operate the tiller without proper instruction.

3. Keep the area of operation clear of all persons, particularly children and pets.

4. Keep in mind that the operator or user is responsible for accidents or hazards occurring to other people, their property, and themselves.

### Preparation

1. Thoroughly inspect the area where the tiller is to be used and remove all foreign objects.

2. Be sure all control levers are released and the Wheel Gear Lever is in ENGAGE position before starting the engine.

3. Do not operate the tiller without wearing adequate outer garments. Avoid loose garments or jewelry that could get caught in moving parts.

4. Do not operate the tiller when barefoot or wearing sandals, sneakers, or light footwear. Wear protective footwear that will improve footing on slippery surfaces.

5. Do not till near underground electric cables, telephone lines, pipes or hoses. If in doubt, contact your telephone or utility company.

6. Warning: Handle fuel with care; it is highly flammable and its vapors are explosive. Take the following precautions:

- a. Store fuel in containers specifically designed for this purpose.
- b. The gas cap shall never be removed or fuel added while the engine is running. Allow the engine to cool for several minutes before adding fuel.
- c. Keep matches, cigarettes, cigars, pipes, open flames, and sparks away from the fuel tank and fuel container.
- d. Fill fuel tank outdoors with extreme care. Never fill fuel tank indoors. Use a funnel or spout to prevent spillage.
- e. Replace all fuel tank and container caps securely.
- f. If fuel is spilled, do not attempt to start the engine, but move the machine away from the area of spillage and avoid creating any source of ignition until fuel vapors have dissipated.

7. Never make adjustments when engine is running (unless recommended by manufacturer).

### Operation

1. Do not put hands or feet near or under rotating parts.

2. Exercise extreme caution when on or crossing gravel drives, walks, or roads. Stay alert for hidden hazards or traffic. Do not carry passengers.

3. After striking a foreign object, stop the engine, remove the wire from the spark plug and prevent it from touching the spark plug, thoroughly inspect the machine for any damage, and repair the damage before restarting and operating the machine.

4. Exercise caution to avoid slipping or falling.

5. If the unit should start to vibrate abnormally, stop the engine, disconnect the spark plug wire and prevent it from touching the spark plug, and check immediately for the cause. Vibration is generally a warning of trouble.

6. Stop the engine, disconnect the spark plug wire and prevent it from touching the spark plug whenever you leave the operating position, before unclogging the tines, or when making any repairs, adjustments or inspections.

## Section 1: Safety

7. Take all possible precautions when leaving the machine unattended. Stop the engine. Disconnect spark plug wire and move it away from the spark plug. Move Wheel Gear Lever to ENGAGE.

8. Before cleaning, repairing, or inspecting, stop the engine and make certain all moving parts have stopped. Disconnect the spark plug wire and prevent it from touching the spark plug to prevent accidental starting.

9. Always keep the tiller tine hood flap down, unless using the tiller/furrower attachment.

10. Never use the tiller unless proper guards, plates, or other safety protective devices are in place.

11. Do not run engine in an enclosed area. Engine exhaust contains carbon monoxide gas, a deadly poison that is odorless, colorless, and tasteless.

12. Keep children and pets away.

13. **Never operate the tiller under engine power if the Wheel Gear Lever is in DISENGAGE (FREEWHEEL). In this position, the wheels will not hold the tiller back and the revolving tines could propel the tiller rapidly, possibly causing loss of control.** Always move the Wheel Gear Lever to ENGAGE before starting the engine or engaging the tines/wheels with the Forward Clutch or the Maneuvering Clutch.

14. **Be aware that the tiller may unexpectedly bounce upward or jump forward if the tines should strike extremely hard packed soil, frozen ground, or buried obstacles like large stones, roots, or stumps. If in doubt about the tilling conditions, always use the following operating precautions to assist you in maintaining control of the tiller:**

- a. **Walk behind and to one side of the tiller, using one hand on the handlebars. Relax your arm, but use a secure hand grip.**
- b. **Use shallower depth regulator settings, working gradually deeper with each pass.**
- c. **Place the forward drive belt in its LOW Range position. Use slower**

**engine speeds.**

- d. **Clear the tilling area of all large stones, roots and other debris.**
- e. **Avoid using downward pressure on handlebars. If need be, use slight upward pressure to keep the tines from digging too deeply.**
- f. **Before contacting hard packed soil at the end of a row, reduce engine speed and lift handlebars to raise tines out of the soil.**
- g. **In an emergency, stop tines and wheels by releasing whichever Clutch Lever is engaged. Do not attempt to restrain the tiller.**

15. Do not overload the tiller's capacity by attempting to till too deeply at too fast a rate.

16. Never operate the tiller at high transport speeds on hard or slippery surfaces. Look behind and use care when backing up.

17. Do not operate the tiller on a slope that is too steep for safety. When on slopes, slow down and make sure you have good footing. Never permit the tiller to freewheel down slopes.

18. Never allow bystanders near the unit.

19. Only use attachments and accessories that are approved by Garden Way Inc.

20. Use tiller attachments and accessories when recommended.

21. Never operate the tiller without good visibility or light.

22. Never operate the tiller if you are tired, or under the influence of alcohol, drugs or medication.

23. Operators shall not tamper with the engine-governor settings on the machine; the governor controls the maximum safe operating speed to protect the engine and all moving parts from damage caused by overspeed. Authorized service shall be sought if a problem exists.

24. Do not touch engine parts which may be hot from operation. Let parts cool down sufficiently.

25. Please remember: You can always stop the tines and wheels by releasing the Forward Clutch Lever or the Maneuvering Clutch Lever (whichever lever you have engaged) or by moving the Throttle Control Lever to STOP.

26. To load or unload the tiller, see the instructions in Section 4 of this Manual.

27. Use extreme caution when reversing or pulling the machine towards you.

28. Start the engine carefully according to instructions and with feet well away from the tines.

29. Never pick up or carry a machine while the engine is running.

## Maintenance and Storage

1. Keep the tiller, attachments and accessories in safe working condition.

2. Check all nuts, bolts, and screws at frequent intervals for proper tightness to be sure the equipment is in safe working condition.

3. Never store the tiller with fuel in the fuel tank inside a building where ignition sources are present such as hot water and space heaters, furnaces, clothes dryers, stoves, electric motors, etc. Allow engine to cool before storing in any enclosure.

4. To reduce the chances of a fire hazard, keep the engine free of grass, leaves, or excessive grease.

5. Store gasoline in a cool, well-ventilated area, safely away from any spark- or flame-producing equipment. Store gasoline in an approved container, safely away from the reach of children.

6. Refer to the Maintenance sections of this Manual and the separate Engine Owner's Manual for instructions if the tiller is to be stored for an extended period.

7. Never perform maintenance while the engine is running or the spark plug wire is connected, except when specifically instructed to do so.

8. If the fuel tank has to be drained, do this outdoors.

## Decals

For your safety and the safety of others, various safety and operational decals are located on your unit (see Figure 1 below).

Keep the decals clean and legible at all times. Contact your local service dealer or the factory for replacements if any decals are damaged or missing.

Refer to the separate parts catalog for decal locations, part numbers and ordering instructions.

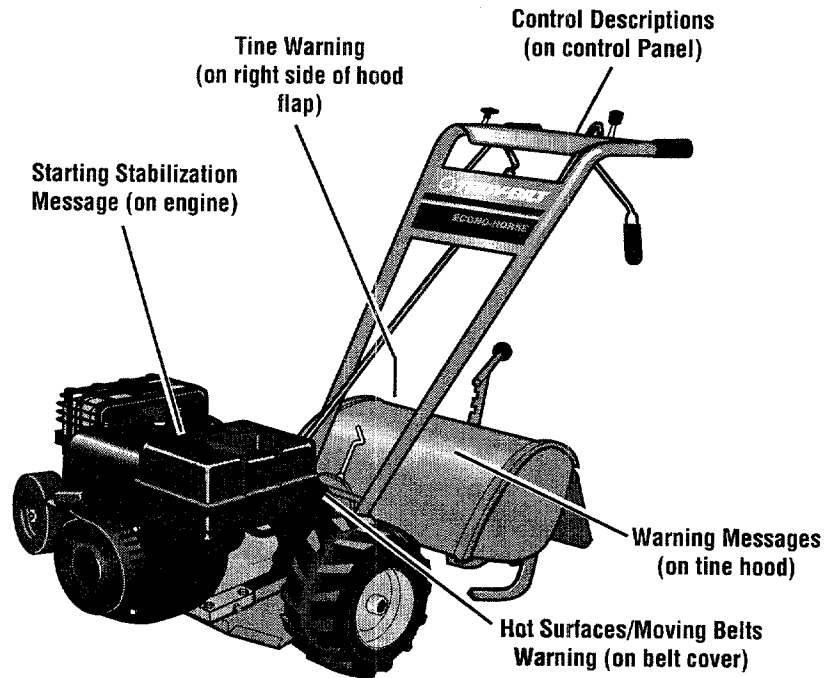

Figure 1: Location of Safety and Operating Decals

| Operating Symbols  |      |      |                  |                |
|--|------|------|------------------|----------------|
| Various symbols (shown here, with word descriptions) may be used on the tiller and engine. |      |      |                  |                |
|  |      |      |                  |                |
| FAST   | SLOW | STOP |                  |                |
|  |      |      | TILLER DIRECTION | REVERSE        |
|  |      |      |                  |                |
|  |      |      | LEVER DIRECTION  | ROTATING TINES |

**! WARNING**

**TO AVOID SERIOUS INJURY:**

- READ THE OWNER'S MANUAL.
- KNOW LOCATIONS AND FUNCTIONS OF ALL CONTROLS.
- KEEP ALL SAFETY DEVICES AND SHIELDS IN PLACE AND WORKING.
- NEVER ALLOW CHILDREN OR UNINSTRUCTED ADULTS TO OPERATE TILLER.
- SHUT OFF ENGINE AND DISCONNECT SPARK PLUG WIRE BEFORE MANUALLY UNCLOGGING TINES OR MAKING REPAIRS.
- KEEP BYSTANDERS AWAY FROM MACHINE.
- KEEP AWAY FROM ROTATING PARTS.
- USE EXTREME CAUTION WHEN REVERSING OR PULLING THE MACHINE TOWARDS YOU.

# Section 2 Assembly



## WARNING

To prevent personal injury or property damage, do not start the engine until all assembly steps are complete and you have read and understand the safety and operating instructions in this manual.

## Introduction

Carefully follow these assembly steps to correctly prepare your tiller for use. It is recommended that you read this Section in its entirety before beginning assembly.

## Inspect unit

Inspect the unit and carton for damage immediately after delivery. Contact the carrier (trucking company) if you find or suspect damage. Inform them of the damage and request instructions for filing a claim. To protect your rights, put your claim in writing and mail a copy to the carrier within 15 days after the unit has been delivered. Contact us at the factory if you need assistance in this matter.

## STEP 1: Unpacking Instructions

1. Remove any cardboard inserts and packaging material from the carton. Remove any staples from the bottom of the carton and then lift the carton up and off the unit.
2. The tiller is heavy and you should not attempt to remove it from the shipping platform until the handlebars are installed and the Wheel Gear Lever is placed in DISENGAGE. The procedure for removing the tiller is explained in Step 2 of these assembly steps.
3. Remove the handlebar assembly from the carton. Do not remove the two control levers from the handlebars.

4. Remove the separate hardware bag from the carton. Check that you have the items listed below and shown in Fig. 2-1. Contact your local dealer or the factory if any items are missing or damaged.

### Hardware Parts List

| Fig. Ref. | Qty. | Description                   |
|-----------|------|-------------------------------|
| 1         | 1    | Height Adjustment Handle      |
| 2         | 1    | Keyed Washer                  |
| 3         | 4    | Plastic Tie Strap             |
| 4         | 3    | Hairpin Cotter                |
| 5         | 2    | 3/8"-16 x 1" Hex Hd. Screw    |
| 6         | 2    | 3/8" Flat Washers             |
| 7         | 2    | 3/8"-16 Nylock Lock Nuts      |
| 8         | 1    | Throttle Lever Knob           |
| 9         | 4    | #10-32 x 1/2" Round Hd. Screw |
| 10        | 4    | #10 Lockwashers               |
| 11        | 4    | #10-32 Nuts                   |
| 12        | 1    | Wheel Gear Lever Knob         |

## Tools/Materials Needed for Assembly

- (1) 3/8" open-end wrench\*
  - (2) 9/16" open-end wrenches\*
  - (1) Scissors (to trim plastic ties)
  - (1) Ruler
  - (1) Small board (to tap plastic knobs on control levers)
  - (1) Automotive-type air pressure gauge
  - (1) Clean oil funnel
  - (1) Clean, high-quality engine oil. Refer to the Engine Owner Manual for engine oil specifications and quantity required. Do not overfill.
- \* Adjustable wrenches may be used.

**IMPORTANT:** Motor oil must be added to the engine crankcase before the engine is started. Follow the instructions in this "Assembly" section.

NOTE: LEFT and RIGHT sides of the tiller are as viewed from the operator's position behind the handlebars.

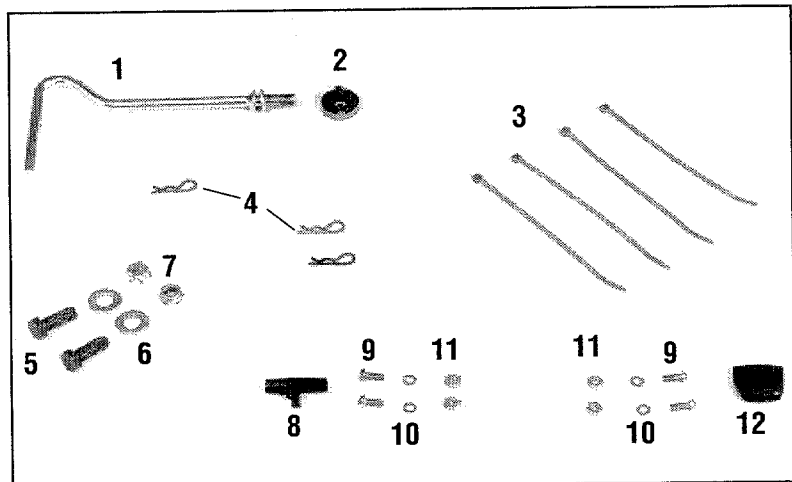

Figure 2-1: Loose hardware (see parts list).

## STEP 2: Attach Handlebars

1. Remove the Maneuvering Clutch Lever (B, Figure 2-2) from the handlebars (A). Remove any rubber bands from the handlebars.

2. Position the handlebar cross-brace (C, Figure 2-3) in front of the curved height adjustment bracket (D) and place the handlebar ends to the outside of the two mounting tabs on top of the transmission.

3. Attach the handlebars to the mounting tabs with two 3/8"-16 x 1" screws (heads of screws go to inside of tabs), 3/8" flat washers and 3/8"-16 Nylock locknuts (see Figure 2-3). Do not fully tighten the screws at this time.

4. Move the handlebar to align the hole in the cross-brace with one of the four slots in the curved height adjustment bracket. Place the keyed washer (E, Figure 2-4) on the height adjustment handle (F) with the raised keys (edges) on the washer facing down.

5. Thread the height adjustment handle (F) into the threaded hole in the handlebar cross-brace, making sure that the raised keys on the washer fit into the selected slot on the curved bracket. Tighten the handle securely. Next, securely tighten the two screws that attach the handlebars ends to the mounting tabs (Figure 2-3).

6. To remove the tiller from its shipping platform, first carefully unwrap the Wheel Gear Lever and cable assembly (G, Figure 2-5) from around the engine. Next, move the lever to the DISENGAGE position (this allows the wheels to rotate).

**IMPORTANT:** Use the DISENGAGE position only when the engine is not running. Before starting the engine, the Wheel Gear Lever must be placed in the ENGAGE position (see Section 3 for details).

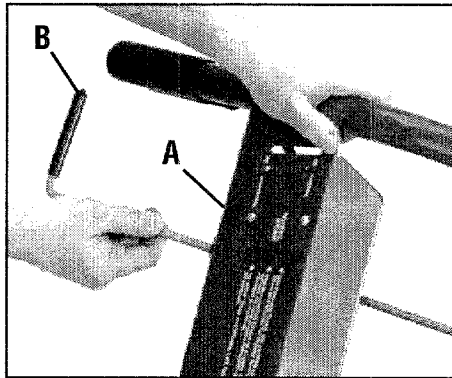

Figure 2-2: Remove Maneuvering Clutch Lever.

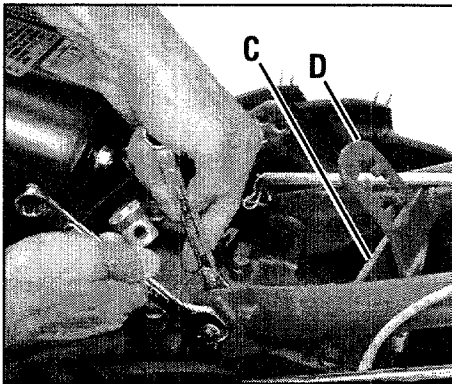

Figure 2-3: Attach handlebars.

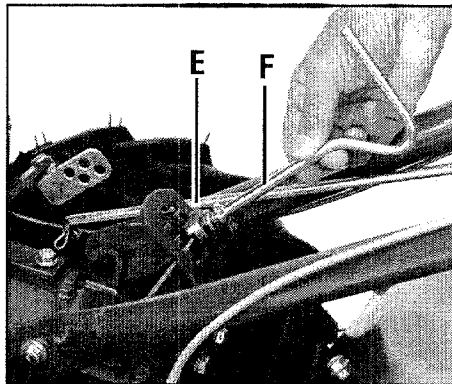

Figure 2-4: Install height adjustment handle.

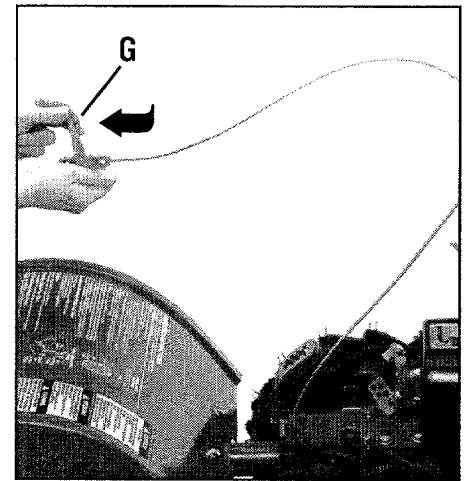

Figure 2-5: Put Wheel Gear Lever in DISENGAGE position.

## STEP 3: Attach Maneuvering Clutch Lever

1. Slide the Maneuvering Clutch Lever (removed in Step 2) down through the hole in the left side of the handlebar control panel and pass it above the cross-brace at the lower end of the handlebar.

2. Turn the lever (I, Figure 2-6) so that the small bend at its lower end points inward toward the pivot (J, Figure 2-6) on the left side of the unit.

3. Insert the tip of the lever into the hole in the pivot (J) and secure the lever with a hairpin cotter (K).

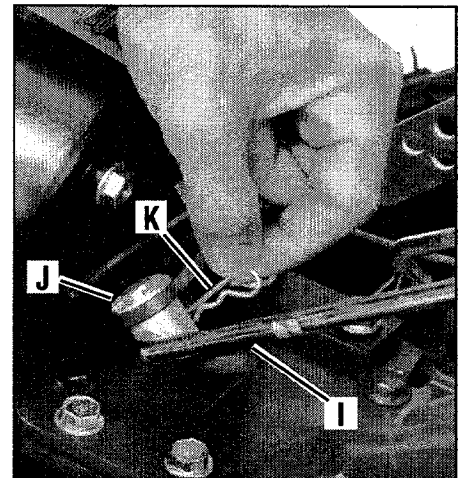

Figure 2-6: Install Maneuvering Clutch Lever.

## Section 2: Assembly

### STEP 4: Attach Forward Clutch Rod

1. The upper end of the Forward Clutch rod is attached to the bottom of the handlebar control panel. Turn the rod (L, Figure 2-7) so that the small bend at its lower end points inward toward the clutch swivel plate (H).

2. Insert a hairpin cotter down through the hole in the rod that is located closest to the bend (see Figure 2-7).

3. There are four numbered holes in the clutch swivel plate (see Figure 2-8) and four numbered slots in the curved height adjustment bracket. For correct operation of the Forward Clutch rod, the numbered hole used for the Forward Clutch rod must match with the numbered slot in the height adjustment bracket. For example, if the handlebar is set in slot #1, then the Forward Clutch rod must be installed in hole #1 of the clutch swivel plate.

**IMPORTANT:** Whenever the handlebar height is changed, the hole position of the Forward Clutch rod must be changed accordingly. Changing the handlebar height changes the tension on the Forward Clutch rod – this tension must be adjusted by relocating the rod in the appropriate hole in the clutch swivel plate.

4. Select the proper hole in the clutch swivel plate and insert the Forward Clutch rod so that the tip faces **inward** (see Figure 2-8). *Secure the rod by inserting a second hairpin cotter through the hole near the tip of the rod.* NOTE: If tip of rod is incorrectly installed so that it faces outward, it will interfere with the height adjustment handle.

5. Check for correct tension on the Forward Clutch rod as follows:

- There are two interconnected Forward Clutch paddles that hang beneath the control panel. Lift and hold the right-side paddle against the handlebar grip.
- While squeezing the paddle, measure the gap between the E-ring and the lower end of the clutch rod bracket (see Figure 2-9). The gap should be 3/16"-to-5/16". NOTE: A stack of five pennies is approximately 5/16" thick.

(c) If the gap is incorrect:

- First check that the Forward Clutch rod is in the correct hole in the clutch swivel plate. If not, reposition the rod and repeat Step 5b.
- If the Forward Clutch rod is in the correct hole and the gap is incorrect, you will need to adjust the length of the Forward Clutch rod. To do this, first release the Forward Clutch paddle and then disconnect the rod from the clutch swivel plate (remove hairpin cotter at end of rod and pull rod out of hole in clutch swivel plate).

*If the gap is more than 5/16", rotate the rod counterclockwise (as viewed from the front of tiller) to decrease the gap. Reinstall the rod in the correct clutch swivel plate hole, secure it with the hairpin cotter, and repeat Steps 5a and 5b.*

*If the gap is less than 3/16", rotate the rod clockwise (as viewed from the front of tiller) to increase the gap. Reinstall the rod in the correct clutch swivel plate hole, secure it with the hairpin cotter, and repeat Steps 5a and 5b.*

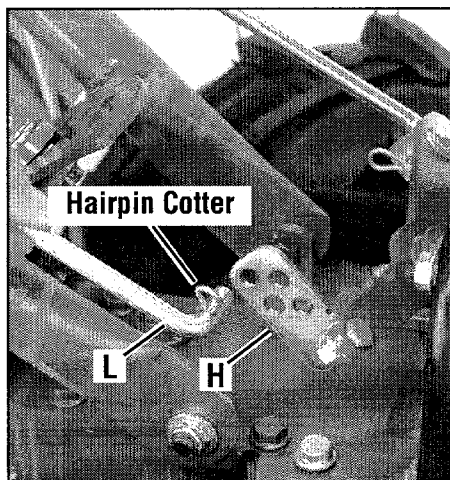

Figure 2-7: Install Forward Clutch rod.

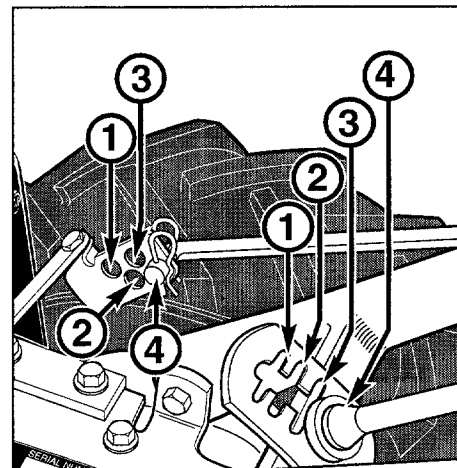

Figure 2-8: Numbered settings for handlebar height slots and clutch swivel plate holes.

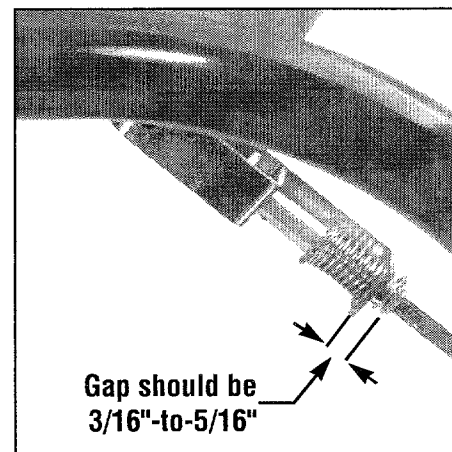

Figure 2-9: While squeezing Forward Clutch paddle, measure gap between end of bracket and E-ring.

### STEP 5: Check Gear Oil Level in Transmission

The transmission was filled with gear oil at the factory. However, you should check the gear oil level to make certain it is correct.

**IMPORTANT:** Do not operate the tiller if the gear oil level is low. Doing so will result in severe damage to the transmission components.

- Move the tiller to a level area.
- Pull the Depth Regulator Lever (M, Figure 2-10) straight back and then slide it to the second notch from the top. If the lever does not move freely, lift the tine hood flap and look for a plastic tie securing the lever in place. Cut and remove the tie.



3. Remove the oil level check plug (N, Figure 2-11) on the left-side of the transmission. (Due to dried paint on the plug threads, it may require some force to remove the plug the first time.) The gear oil level is correct if oil starts to flow out of the hole as the plug is removed. If so, securely reinstall the plug.

4. If oil does not flow from the check hole, add SAE 140, SAE 85W-140 or SAE 80W-90 weight gear oil (preferably use API rated GL-4 gear oil, however GL-5 can be used for small top-offs) as follows:

NOTE: Do not use automatic transmission fluid or motor oil in the transmission.

- Clean area around oil fill hole (O, Figure 2-12) and unscrew oil fill plug.
- Using a clean funnel, slowly add gear oil until it flows from the oil level check hole (N, Figure 2-11). Securely reinstall the oil level check plug (N).
- Reinstall and tighten the oil fill plug.

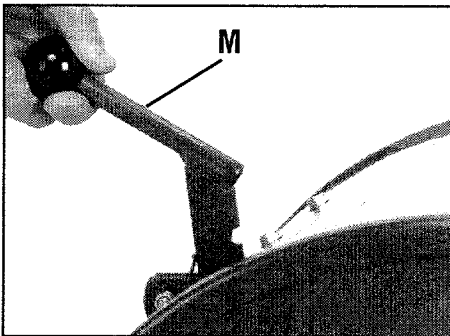

Figure 2-10: Put lever in second notch.

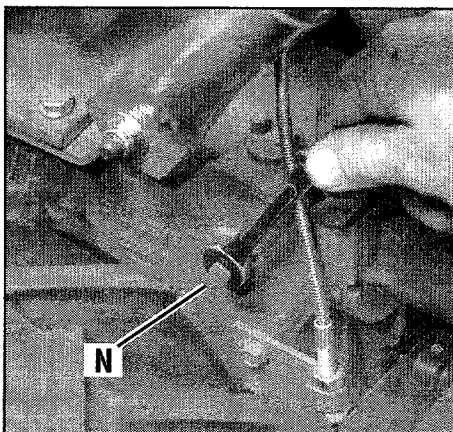

Figure 2-11: Gear oil level check plug.

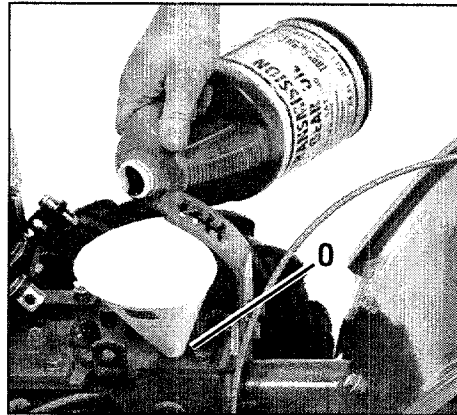

Figure 2-12: Adding gear oil.

### STEP 6: Add Motor Oil to Engine

The tiller is shipped without oil in the engine.

**IMPORTANT:** Do not start the engine without first adding motor oil. Severe engine damage will result if the engine is run without oil.

- With the unit on level ground, pull the Depth Regulator Lever (M, Figure 2-10) back and then move it up or down as needed until the engine is level.
- Add motor oil according to the instructions provided in the engine manufacturer's Engine Owner's Manual that was included in the unit's literature package.

### STEP 7: Attach Engine Throttle Lever

For shipping purposes, the engine throttle cable assembly is wrapped around the engine. Carefully unwrap the cable and attach it as follows:

- Route the throttle cable up the right-side handlebar and insert the lever (P, Figure 2-13) up through the slot in the control panel that is labeled "ENGINE THROTTLE."
- Insert two #10-32 x 1/2" round head screws down through the "+" marks on the control panel decal and through the holes in the base of the engine throttle lever.

3. Hold the engine throttle lever base against the bottom of the control panel and secure it with two #10 lockwashers and #10-32 nuts.

4. Place the "T" shaped engine throttle lever knob on the end of the lever and use a board to tap the knob down until it seats firmly on the lever (see Figure 2-13).

5. Move the lever forward and backward – it should move freely through the full range of travel. (Note that there is a detent at the SLOW setting which catches the lever. This detent prevents the lever from unintentionally moving to the STOP setting when you are just trying to slow the engine down.) If the lever is difficult to move away from the STOP setting, loosen both screws and move the lever assembly slightly to the left. Retighten both screws and recheck the movement. Adjust the lever as needed.

6. Secure the throttle cable to the right-side handlebar with two plastic ties (R, Figure 2-14) located about two feet apart. The serrated side of the tie should be on the inside of the loop. Snip off any excess tie length with scissors.

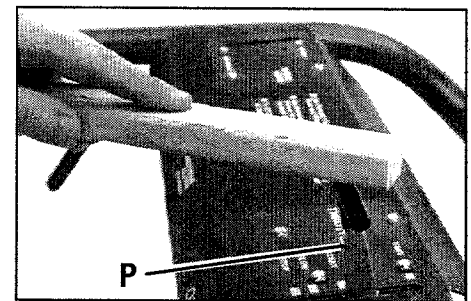

Figure 2-13: Attach engine throttle lever.

## Section 2: Assembly

### STEP 8: Attach Wheel Gear Lever

For shipping purposes, the wheel gear cable is wrapped around the transmission. Carefully unwrap the cable and attach it as follows:

1. Route the wheel gear cable up the left-side handlebar and insert the lever (S, Figure 2-15) up through the slot in the control panel that is labeled "WHEEL GEAR."
2. Insert two #10-32 x 1/2" round head screws down through the "+" marks on the control panel decal and through the holes in the base of the wheel gear lever.
3. Hold the wheel gear lever base against the bottom of the control panel and secure it with two #10 lockwashers and #10-32 nuts.
4. Place the wheel gear lever knob on the end of the lever and use a board to tap the knob down until it seats firmly on the lever (see Figure 2-15).
5. Secure the cable to the left-side handlebar with two plastic ties (T, Figure 2-14) located about two feet apart. Snip off any excess tie length with scissors.

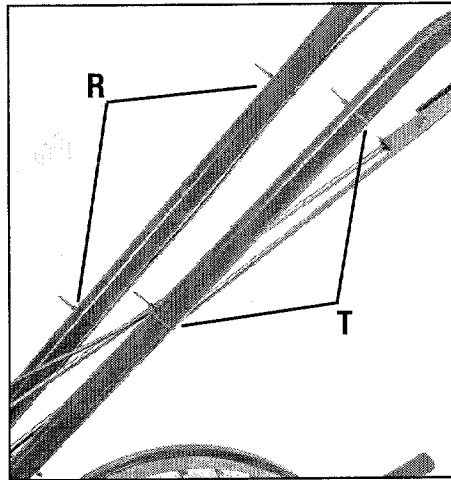

**Figure 2-14:** Attach throttle cable with plastic ties (R). Attach wheel gear cable with plastic ties (T).

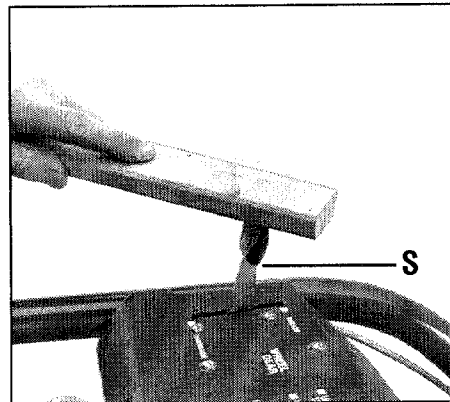

**Figure 2-15:** Attach wheel gear lever.

### STEP 9: Check Air Pressure in Tires

Use an automotive-type tire pressure gauge to check the air pressure in both tires. Deflate or inflate both tires evenly from 15-to-20 PSI (pounds per square inch). Be sure that both tires have the same air pressure or the unit will pull to one side.

### STEP 10: Check Hardware for Tightness

Inspect the hardware on the unit and tighten any loose screws, bolts and nuts.

**IMPORTANT:** This completes the assembly steps. Be sure to read the rest of this Manual before you attempt to operate your tiller.

# Section 3 Features and Controls



## WARNING

Before operating your machine, carefully read and understand all safety, controls and operating instructions in this Manual, the separate Engine Owner's Manual, and on the decals on the machine.

Failure to follow these instructions can result in serious personal injury.

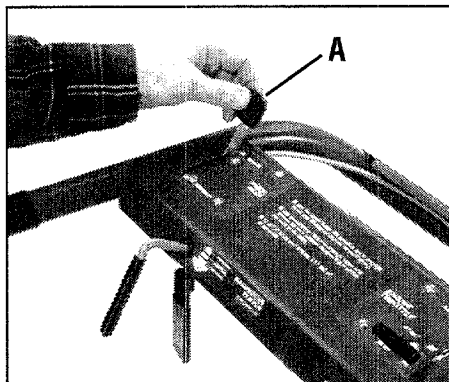

Figure 3-1: Wheel Gear Lever.

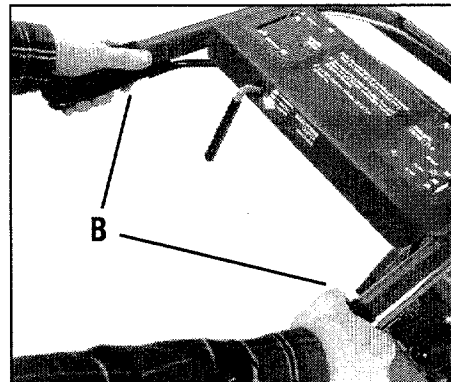

Figure 3-2: Forward Clutch levers.

## TILLER FEATURES AND CONTROLS

This section describes the location and function of the controls on your tiller. Refer to the following section "Operation" for detailed operating instructions.

Practice using these controls, with the engine shut off, until you understand the operation of the controls and feel confident with each of them.

**IMPORTANT:** Refer to the separate engine manufacturer's Engine Owner's Manual for information about the controls on the engine.

### Wheel Gear Lever

This lever (A, Figure 3-1) has two positions: ENGAGE and DISENGAGE.

In the ENGAGE position, the wheels will start turning when either the Forward Clutch or the Maneuvering Clutch is engaged (the tines will also start turning when either clutch is engaged).

The DISENGAGE position places the wheels in the freewheeling mode to allow the unit to be moved without the engine running. Use the DISENGAGE position only when the engine is not running. See "DANGER" statement that follows.

To shift to ENGAGE, gently (do not force) move the lever forward while also rolling

the tiller a few inches forward or backward. (Moving the tiller helps to align the shift mechanism with the transmission wheel drive gears.) The wheels will not freewheel when the lever is properly set in the ENGAGE position.

To shift to DISENGAGE (freewheel) simply move the lever rearward, without rolling the tiller. The wheels will roll freely when the lever is properly set in the DISENGAGE position.



## DANGER

Never place the Wheel Gear Lever in DISENGAGE (Freewheel) when the engine is running.

Having the Wheel Gear Lever in DISENGAGE and then engaging the tines/wheels with either the Forward Clutch or the Maneuvering Clutch could allow the tines to propel the tiller rapidly forward or backward.

Failure to follow this instruction could result in personal injury or property damage.

## Forward Clutch

The two interconnected levers (B, Figure 3-2) control the engagement of forward drive to the wheels and tines.

### To Operate the Forward Clutch:

1. Before engaging the Forward Clutch, put the Wheel Gear Lever in the ENGAGE position (see "WARNING" below).
2. Lift and hold one or both of the levers against the handlebar grips to engage the wheels and tines.
3. Release BOTH levers to disengage the wheels and tines. All forward motion will stop (the engine will continue to run).



## WARNING

Never engage the wheels and tines with the Forward Clutch or the Maneuvering Clutch unless the Wheel Gear Lever is in ENGAGE.

Engaging the Forward Clutch or the Maneuvering Clutch when the wheels are not engaged could allow the tines to rapidly propel the tiller forward or backward.

Failure to follow this warning could result in personal injury or property damage.

## Section 3: Features and Controls

### Maneuvering Clutch

This lever (C, Figure 3-3) controls the engagement of forward or reverse drive to the wheels and tines. It is used for short distance, precise maneuvering in a forward direction and is the only control that provides reverse direction of the wheels and tines.

#### To Operate the Maneuvering Clutch:

1. Before engaging the Maneuvering Clutch, put the Wheel Gear Lever in ENGAGE (see "WARNING" statement on previous page).
2. For precision tilling (such as near obstacles), release the Forward Clutch levers and push the Maneuvering Clutch lever in. To stop the wheels and tines, release the lever and it will return to NEUTRAL.
3. To move forward for a short distance without tilling the soil, release the Forward Clutch levers and lift the handlebars until the tines clear the ground. Then push the Maneuvering Clutch lever in. To stop the wheels and tines, release the lever and it will return to NEUTRAL.
4. To move the tiller in reverse, first stop all forward motion. Then lift up the handlebars until the tines clear the ground and pull the Maneuvering Clutch lever out. The tines and wheels will rotate in a reverse direction as long as the lever is held in REVERSE. To stop the wheels and tines, release the lever and it will return to NEUTRAL. **Never attempt to till while going in the reverse direction.**



#### WARNING

- Use extreme caution when reversing or pulling the machine towards you. Look behind to avoid obstacles.
  - Never attempt to till in reverse.
- Failure to follow this warning could result in personal injury or property damage.

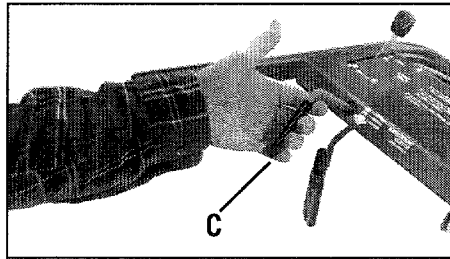

Figure 3-3: Maneuvering Clutch lever.

### Depth Regulator

This lever (D, Figure 3-4) controls the tilling depth of the tines. Pull the lever straight back and slide it up or down to engage the notched height settings.

The highest notch (lever all the way down) raises the tines approximately 1-1/2 inches off the ground. This "travel" position allows the tiller to be moved without the tines digging into the ground.

Moving the lever up increases the tilling depth. The lowest notch allows a tilling depth of approximately six to eight inches, depending on soil conditions.

**For best results, always begin tilling at a very shallow depth setting and gradually increase the tilling depth.** Complete details on using the Depth Regulator are found in the "Operation" Section of this manual.



#### WARNING

Always place the Depth Regulator Lever in the "travel" position before starting the engine. This position prevents the tines from touching the ground until you are ready to begin tilling.

Failure to follow this warning could result in personal injury or property damage.

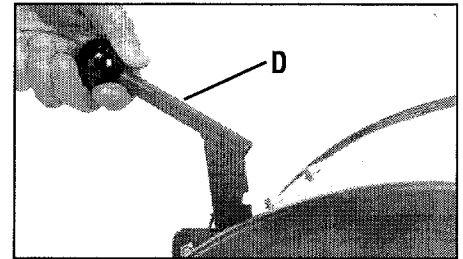

Figure 3-4: Depth Regulator Lever.

### Handlebar Height Adjustment

The handlebar height is adjustable to four different settings. Set the handlebar height to a comfortable setting, but keep in mind that the handlebars will be lower when the tines are engaged in the soil.



#### WARNING

Whenever the handlebar height is changed, the Forward Clutch shift mechanism must be readjusted.

When adjusting or checking the Forward Clutch mechanism, shut engine off, disconnect spark plug wire and prevent it from touching the spark plug.

Failure to follow this warning could allow the Forward Clutch mechanism to operate improperly which could result in personal injury or property damage.

#### To Adjust the Handlebar Height:

1. Stop the engine, wait for all parts to stop moving and then disconnect the spark plug wire.
2. Loosen the two screws at the lower ends of the handlebar.
3. Loosen the height adjustment handle (E, Figure 3-5) and pull the keyed washer (F) free of the slots in the curved height adjustment bracket.
4. Move the handlebars to the new slot setting and insert the raised keys on the keyed washer into the slot. Tighten the height adjustment handle securely.

5. Retighten the two screws at the ends of the handlebar.
6. Adjust the tension on the Forward Clutch rod shift mechanism, as follows:
  - (a) Remove the inner hair pin cotter from the end of the Forward Clutch rod.
  - (b) There are four numbered holes in the clutch swivel plate (see Figure 3-6) and four numbered slots in the curved height adjustment bracket. For correct operation of the Forward Clutch mechanism, the numbered hole used for the Forward Clutch rod must match the numbered slot in the height adjustment bracket. Example: If handlebar is in slot #4, put Forward Clutch rod in hole #4 of clutch swivel plate.
  - (c) Select the correct hole in the clutch swivel plate and insert the Forward Clutch rod (tip faces inward). Secure the rod with the hairpin cotter.
  - (d) Check for correct tension on the Forward Clutch rod as described in item 5 of "Step 4: Attach Forward Clutch Rod" on page 8.

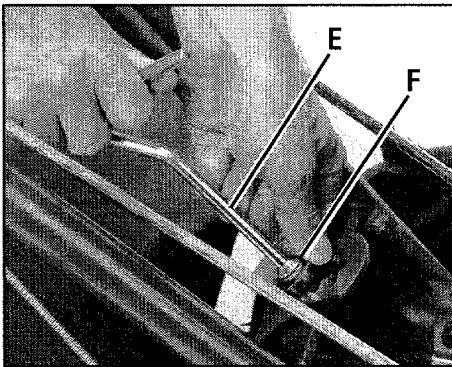

Figure 3-5: Height Adjusting handle (E).

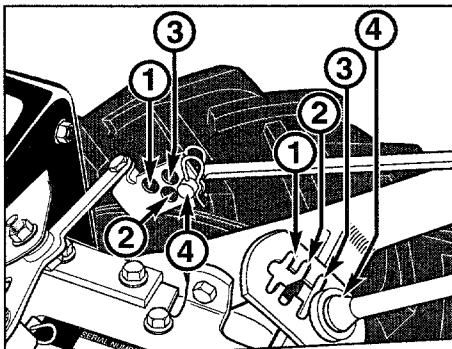

Figure 3-6: Handlebar height slots and clutch swivel plate holes.

### ENGINE CONTROLS

**IMPORTANT:** The engine is equipped with either a choke control or a primer bulb. Refer to the engine manufacturer's Engine Owner's Manual (included in the tiller literature package) to identify which device is on your engine.

#### Recoil Starter

The recoil starter (G, Figure 3-7) is used to "pull-start" the engine.

Before pulling the recoil starter handle, make sure there are no obstacles behind you. See "Engine Starting and Stopping" in the Operation Section for detailed engine starting instructions.

#### Engine Throttle Lever

The throttle lever (Figure 3-8) is used to adjust engine speed as well as stop the engine.

Use the START position when starting the engine. Use the SLOW position when idling the engine. Pull the lever all the way back to the STOP position to shut the engine off.

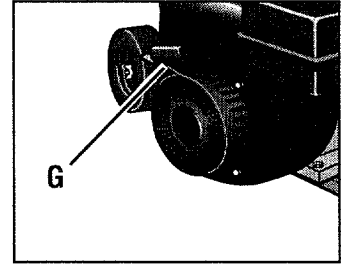

Figure 3-7: Recoil Starter.

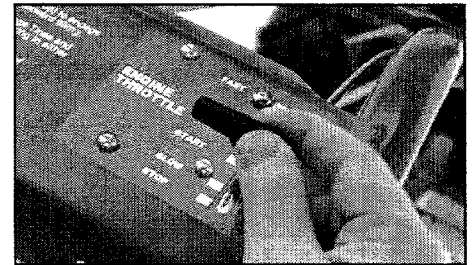

Figure 3-8: Engine Throttle Lever.

# Section 4 Operation



## WARNING

Before operating your machine, carefully read and understand all safety (Section 1), controls (Section 3) and operating instructions (Section 4) in this Manual, in the separate Engine Owner's Manual, and on the decals on the machine.

Failure to follow these instructions can result in serious personal injury.

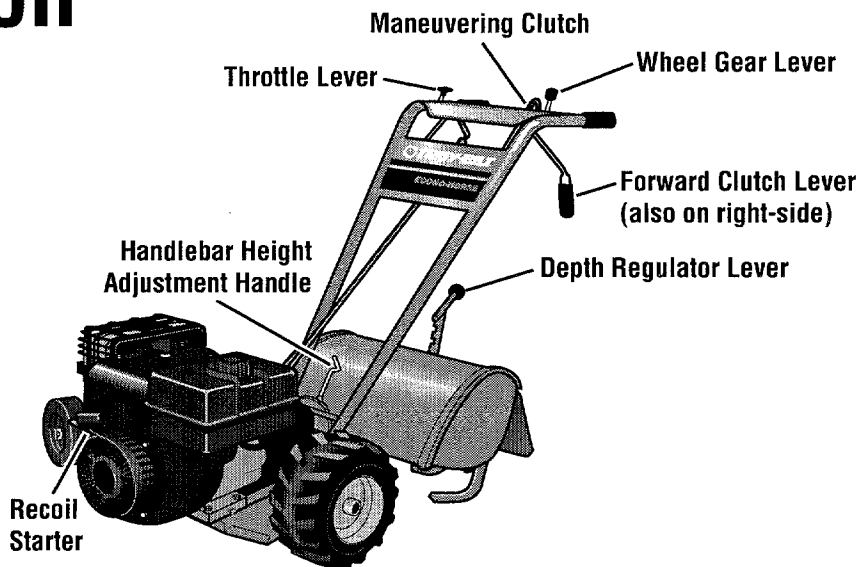

Figure 4-1

## INTRODUCTION

Read this Section of the manual thoroughly before you start the engine. Then, take the time to familiarize yourself with the basic operation of the tiller before using it in the garden. Find an open, level area and practice using the tiller controls without the tines engaging the soil (put tines in "travel" setting). Only after you've become completely familiar with the tiller should you begin using it in the garden.

## BREAK-IN OPERATION

Perform the following maintenance during the first hours of new operation (see "Maintenance" section of this manual and the Engine Owner's Manual).

1. Change engine oil after first 2 hours of new engine operation.
2. Check for loose or missing hardware on unit. Tighten or replace as needed.
3. Check tension on forward drive belt after first 2 hours of operation.
4. Check transmission gear oil level after first 2 hours of operation.

## STARTING AND STOPPING THE ENGINE

### Pre-Start Checklist

Make the following checks and perform the following services before starting the engine.

1. Read the "Safety" and "Controls" sections in this manual. Read the separate Engine Owner's Manual provided by the engine manufacturer.
2. Check unit for loose or missing hardware. Service as required.
3. Check engine oil level. See Engine Owner's Manual.
4. Check that all safety guards and covers are in place.
5. Check air cleaner and engine cooling system. See Engine Owner's Manual.
6. Move the forward drive belt to the Low or High belt range (see "Changing Belt Range Speeds" in this Section).
7. Attach spark plug wire to spark plug.
8. Fill the fuel tank with gasoline according to the directions in the separate Engine Owner's Manual. Follow all instructions and safety rules carefully.



## DANGER

**GASOLINE IS HIGHLY FLAMMABLE AND ITS VAPORS ARE EXPLOSIVE.**

Follow gasoline safety rules in this manual (see Section 1) and in the separate Engine Owner's Manual.

Failure to follow gasoline safety instructions can result in serious personal injury and property damage.



## CAUTION

To help prevent serious personal injury or damage to equipment:

- Before starting engine, put Wheel Gear Lever in ENGAGE position.
- Before starting engine, put Forward Clutch Levers and Maneuvering Clutch Lever in neutral (disengaged) positions by releasing levers.
- Never run engine indoors or in enclosed, poorly ventilated areas. Engine exhaust contains carbon monoxide, an odorless and deadly gas.
- Avoid engine muffler and nearby areas. Temperatures in these areas may exceed 150°F.

## Starting the Engine

The following steps describe how to start and stop the engine. **Do not attempt to engage the tines or wheels until you have read all of the operating instructions in this Section. Also review the safety rules in Section 1: "Safety" and the tiller and engine controls information in Section 3: "Features and Controls."**

1. Complete the "Pre-Start Checklist" on the previous page.
2. Put the Wheel Gear Lever (Figure 4-1) in the ENGAGE position.
3. Put the Depth Regulator Lever in the "travel" position (lever all the way down) so that the tines are clear of the ground.
4. Release all controls on the tiller.
5. If the engine is equipped with a fuel shutoff valve, turn the valve to the open position as instructed in the separate Engine Owner's Manual.
6. Put the Engine Throttle Lever in the START setting.
7. Choke or prime the engine as instructed in the separate Engine Owner's Manual.

8. Check behind you before pulling the recoil starter handle to avoid contacting any obstacles when pulling the handle. Place one hand on the fuel tank to stabilize the unit when you pull the starter handle and use the recoil starter to start the engine as instructed in the Engine Owner's Manual. When the engine starts, gradually move the choke lever (on engines so equipped) to the NO CHOKE, CHOKE OFF or RUN position.
9. Use the FAST throttle speed setting when tilling.



## WARNING



Keep away from rotating tines. Rotating tines will cause injury.

## Stopping the Engine

1. To stop the wheels and tines, release the Forward Clutch levers or the Maneuvering Clutch lever (whichever control is in use).
2. To stop the engine, move the Engine Throttle Lever to the STOP position.

## OPERATING THE TILLER

The following pages provide guidelines to using your tiller effectively and safely in various gardening applications. Be sure to read "Tilling Tips & Techniques" in this Section before you actually put the tines into the soil.

This is a traditional "standard rotating tine" tiller with forward rotating tines. It operates completely differently from CRT (Counter Rotating Tines) tillers or from low-cost front tine tillers.

1. Follow the "Pre-Start Checklist" on the previous page. Be sure that the Wheel Gear Lever is in the ENGAGE position.
2. Put the Depth Regulator Lever in the "travel" position (lever all the way down) so that the tines are clear of the ground.

Use this position when practicing with your tiller or when moving to or from the garden. When you are ready to begin tilling, you must move the Depth Regulator Lever to the desired depth setting (see "Tilling Tips & Techniques").

3. Start the engine and allow it to warm up. When warm, put throttle control in fast speed setting.
4. For forward motion of the wheels and tines:
  - (a) Pull the Forward Clutch lever "paddles" up and hold them against the handlebars. To stop forward motion of the wheels and tines, release the "paddles."
  - (b) To go forward in close quarters or for precision tilling, release the Forward Clutch lever "paddles" and push the Maneuvering Clutch lever in. To stop forward motion of the wheels and tines, release the Maneuvering Clutch lever.
  - (c) As the tiller moves forward, relax and let the wheels pull the unit along while the tines dig. Walk behind and a little to one side of the tiller. Use a light but secure grip with one hand on the handlebars, but keep your arm loose. See Figure 4-2. Let the tiller move ahead at its own pace and do not push down on the handlebars to try and force the tiller to dig deeper – this takes weight off the wheels, reduces traction, and causes the tines to try and propel the tiller.



Figure 4-2: Use one hand to guide tiller when moving forward.

## Section 4: Operation



### WARNING

Do not push down on the handlebars to try to make the tiller till more deeply. This prevents the wheels from holding the tiller back and can allow the tines to rapidly propel the tiller forward, which could result in loss of control, property damage, or personal injury.



Figure 4-3: Raise tines off ground and look behind when moving in reverse.

5. For reverse motion of the wheels and tines:

- (a) Look behind and exercise caution when operating in reverse. **Do not till while in reverse.**
- (b) Stop all forward motion before reversing. Lift the handlebars with one hand until the tines are off the ground and then pull the Maneuvering Clutch lever out to engage reverse motion (see Figure 4-3). To stop reverse motion, let go of the Maneuvering Clutch lever.

6. To Turn the Tiller Around:

- (a) Practice turning the tiller in a level, open area. Be very careful to keep your feet and legs away from the tines.
- (b) To make a turn, reduce the engine speed and then lift the handlebars until the engine and tines are balanced over the wheels (Figure 4-4).
- (c) With the tiller balanced, push sideways on the handlebar to move the tiller in the direction of the turn (Figure 4-5). After completing the turn, slowly lower the tines into the soil and increase the engine speed.

### Stopping the Tiller and Engine

1. To stop the wheels and tines, release the Forward Clutch “paddles” or the Maneuvering Clutch Lever (whichever is engaged).
2. To stop the engine, move the Engine Throttle Lever to STOP.

### Turning the Tiller Around



Figure 4-4: To begin turn, reduce engine speed and lift handlebars until engine and tines are balanced over wheels.



Figure 4-5: With tiller balanced over wheels (and tines out of the ground), push handlebars sideways to turn tiller.



# Tilling Tips & Techniques

## Let the tiller do the work

- While tilling, relax and let the wheels pull the tiller along while the tines do the digging. Walk on the side that is not yet finished (to avoid making footprints in the freshly tilled soil) and lightly, but securely grip the handlebar with just one hand. See Figure 4-2.
- Avoid the temptation to push down on the handlebars in an attempt to force the tiller to dig deeper. Doing so takes the weight off the powered wheels, causing them to lose traction. Without the wheels helping to hold the tiller back, the tines will attempt to propel the tiller – often causing the tiller to skip rapidly across the ground. (Sometimes, slight downward pressure on the handlebars will help get through a particularly tough section of sod or unbroken ground, but in most cases this won't be necessary at all.)

## Tilling depths

- **Avoid trying to dig too deeply too quickly, especially when busting sod or when tilling soil that hasn't been tilled for some time.** Use shallow depth regulator settings (only an inch or two deep) for the first passes through the garden area. With each succeeding pass, adjust the depth regulator to dig another inch or two deeper. (Watering the garden area a few days prior to tilling will make tilling easier, as will letting the newly worked soil set for a day or two before making a final, deep tilling pass.)
- When cultivating (breaking up the surface soil around plants to help destroy weeds), adjust the tines to dig only 1-1/2" to 2" deep. Using shallow tilling depths helps prevent injury to plants whose roots often grow close to the surface. If needed, lift up on the handlebars slightly to prevent the tines from digging too deeply. Cultivating on a regular basis not only eliminates weeds, it also loosens and aerates the soil for

better moisture absorption and faster plant growth.

## Avoid tilling soggy, wet soil

- Tilling wet soil often results in large, hard clumps of soil that can interfere with planting. If time permits, wait a day or two after heavy rains to allow the soil to dry before tilling. Test soil by squeezing it into a ball. If it compresses too easily, it is too wet to till.

## Avoid making footprints

- Whenever possible, walk on the untilled side of the unit to avoid making footprints in your freshly tilled or cultivated soil. Footprints cause soil compaction that can hamper root penetration and contribute to soil erosion. They can also "plant" unwanted weed seeds back into the freshly tilled ground.

## Choosing correct wheel and tine speeds

With experience, you will find the "just right" tilling depth and tilling speed combination that is best for your garden.

Set the engine throttle lever at a speed to give the engine adequate power and yet allow it to operate at the slowest possible speed...at least until you have achieved the maximum tilling depth you desire. Faster engine speeds may be desirable when making final passes through the seedbed or when cultivating. Selection of the correct engine speed, in relation to the tilling depth, will ensure a sufficient power level to do the job without causing the engine to labor.

NOTE: Also see "Changing Belt Range Speeds" in this Section.

## Suggested tilling patterns

- When preparing a seedbed, go over the same path twice in the first row, then overlap one-half the tiller width on the rest of the passes (see Figure 4-6). When finished in one direction, make a second pass at a right angle as shown in Figure 4-7. Overlap each pass for best results (in very hard ground it may take three or four passes to thoroughly pulverize the soil).
- If the garden size will not permit lengthwise and then crosswise tilling, then overlap the first passes by one-half a tiller width, followed by successive passes at one-quarter width (see Figure 4-8).
- With planning, you can allow enough room between rows to cultivate (see Figure 4-9). Leave room for the hood width, plus enough extra room for future plant growth.



Figure 4-6

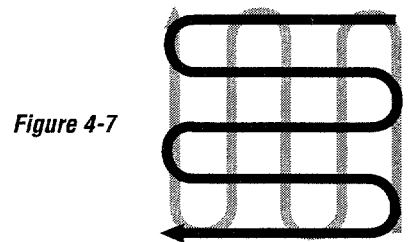

Figure 4-7

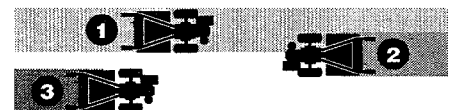

Figure 4-8



Figure 4-9

# Tilling Tips & Techniques

### Clearing the tines

The tines have a self-clearing action which eliminates most tangling of debris in the tines. However, occasionally dry grass, stringy stalks or tough vines may become tangled. Follow these procedures to help avoid tangling and to clean the tines, if necessary.

- To reduce tangling, set the depth regulator deep enough to get maximum “chopping” action as the tines chop the material against the ground. Also, try to till under crop residues or cover crops while they are green, moist and tender.
- While power composting, try swaying the handlebars from side to side (about 6” to 12”). This “fishtailing” action often clears the tines of debris.
- If tangling occurs, lift the tines out of the soil and run the tiller in reverse for a few feet. This reversing action should unwind a good deal of debris.
- If reversing the tiller doesn’t clear the debris, it may be necessary to remove the debris by hand (a pocket knife will help you to cut away the material).



### WARNING

Before clearing the tines by hand, stop the engine, allow all moving parts to stop and disconnect the spark plug wire.

Failure to follow this warning could result in personal injury.

### Tilling on slopes

If you must garden on a moderate slope, please follow two very important guidelines:

1. Till only on moderate slopes, never on steep ground where footing is difficult (review safety rules in the “Safety” section of this manual).
2. We recommend tilling up and down slopes rather than terracing. Tilling vertically on a slope allows maximum planting area and also leaves room for cultivating.

**IMPORTANT:** When tilling on slopes, be sure the correct oil level is maintained in the engine (check every one-half hour of operation). The incline of the slope will cause the oil to slant away from its normal level and this can starve engine parts of required lubrication. Keep the engine oil level at the full point at all times!

#### A. Tilling up and down slopes:

- To keep soil erosion to a minimum, be sure to add enough organic matter to the soil so that it has good moisture-holding texture and try to avoid leaving footprints or wheel marks.
- When tilling vertically, try to make the first pass uphill as the tiller digs more deeply going uphill than it does downhill. In soft soil or weeds, you may have to lift handlebars slightly while going uphill. When going downhill, overlap the first pass by about one-half the width of the tiller.

#### B. Terrace Gardening:

- When a slope is too steep or too short for vertical tilling, it may be necessary to till across the slope and create terraced rows. Terraces are rows that are cut into the side of a slope, creating a narrow, but flat area on which to plant.
- On a long slope, you can make several terraces, one below the other.

- Terraces should be only 2-to-3 feet wide. Digging too far into the side of the slope will expose poor subsoil that is unproductive for plants.
- To create a terrace, start at the top of the slope and work down. Go back and forth across the first row as shown in Figure 4-10.
- Each succeeding lower terrace is started by walking below the terrace you’re preparing. For added stability of the tiller, always keep the uphill wheel in the soft, newly tilled soil. Do not till the last 12” or more of the downhill outside edge of each terrace. This untilled strip helps prevent the terraces from breaking apart and washing downhill. It also provides a walking path between rows.

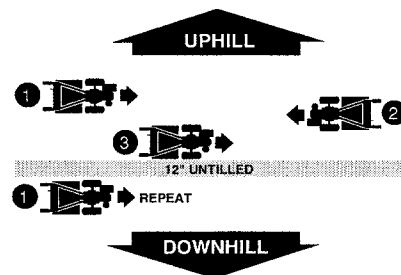

Figure 4-10

#### C. Tilling across slopes without using terraces:

- If vertical or terracing gardening aren’t practical for you, then you can till laterally across a slope. We don’t really recommend this method as it can create unsure footing and invites soil erosion.
- As in terrace gardening, start at the top of the slope and overlap the first pass by half the width of the tiller. For added stability of the tiller, always keep the uphill wheel in the soft, newly tilled soil.



### WARNING

Before tilling, contact your telephone or utilities company and inquire if underground equipment or lines are used in your area. Their representative will be glad to answer your questions and tell you if any of their equipment or lines are buried underground on your property.

### POWER COMPOSTING



### WARNING

When power composting, do not keep the Depth Regulator Lever at a deep setting if the tiller jumps or bucks.

If jumping or bucking occurs, move the Depth Regulator Lever down to one of the shallower settings and then slowly increase the tilling depth on later passes.

Failure to follow this warning could result in personal injury.

Power composting simply means tilling under and burying in the soil all manner of organic matter such as crop residues, leaves, grass clippings and cover crops. This material will decompose during the non-growing season and add important natural nutrients to the soil.

The first place to begin is with crop residues such as leftover vines, stalks, stems and roots. Power compost these crop residues as soon as they finish bearing. The sooner this is done, the better, as tender green matter is easier to till under. Use the deepest depth regulator setting possible without causing the engine to labor or the tiller to jump ahead.

Standing cornstalks of reasonable height can be power composted. Pushing over

(but not uprooting) cornstalks will often make it easier for your tiller to chop up the stalks. Keep the tines clear of excessive tangling by "fishtailing" or frequently using reverse. Make several passes, then return a few days later to finish off any remaining stubble.

After tilling under crop residues, add more organic matter such as leaves, grass clippings and even kitchen scraps. When tilled into the soil, this organic matter will decompose and add even more important nutrients to the soil.

After power composting, you may want to plant a "green manure" cover crop to protect the soil during the off-season.

You simply grow a crop of clover, alfalfa, buckwheat, peas, beans, rye grass, grain, or kale and then till it into the soil prior to the planting season.

### LOADING AND UNLOADING THE TILLER



### WARNING

Loading and unloading the tiller into a vehicle is potentially hazardous and we don't recommend doing so unless absolutely necessary, as this could result in personal injury or property damage.

However, if you must load or unload the tiller, follow the guidelines given next.

- Use sturdy ramps and manually (engine shut off) roll the tiller into and out of the vehicle. Two or more people are needed to do this.
  - Ramps must be strong enough to support the combined weight of the tiller and any handlers. The ramps should provide good traction to prevent slipping; they should have side rails to guide the tiller along the ramps; and they should have a locking device to secure them to the vehicle.
  - The handlers should wear sturdy footwear that will help to prevent slipping.
  - Position the loading vehicle so that the ramp angle is as flat as possible (the less incline to the ramp, the better). Turn the vehicle's engine off and apply its parking brake.
  - When going up ramps, stand in the normal operating position and push the tiller ahead of you. Have a person at each side to turn the wheels.
  - When going down ramps, walk backward with the tiller following you. Keep alert for any obstacles behind you. Position a person at each wheel to control the speed of the tiller. Never go down ramps tiller-first, as the tiller could tip forward.
  - Use wooden blocks to place on the downhill side of the wheels if you need to stop the tiller from rolling down the ramp. Also, use the blocks to temporarily keep the tiller in place on the ramps (if necessary), and to chock the wheels in place after the tiller is in the vehicle.
  - When the tiller is in the vehicle, prevent it from rolling by engaging the wheels in the wheel drive position (put Wheel Gear Lever in ENGAGE). Chock the wheels with blocks and securely tie the tiller down.
- Before loading or unloading, stop the engine, wait for all parts to stop moving, disconnect the spark plug wire and let the engine and muffler cool. Remove the ignition key on electric start models.
  - The tiller is too heavy (over 200 lbs., depending on model) and bulky to lift safely by one person. Two or more people should share the load.

## Section 4: Operation

### CHANGING BELT RANGE SPEEDS

The tiller has two belt range speeds for the wheels and tines: Low and High. The two ranges are obtained by moving the forward drive belt between two sets of grooves on the forward drive pulley and the transmission drive pulley. The decal on top of the belt cover shows the two belt speed positions.

NOTE: The tiller is shipped from the factory with the belt in the Low range position. Keep the belt in this range while familiarizing yourself with the tiller.

Use the Low speed range when more power is needed, such as tilling sod and unworked soil or for tilling under cover crops or extremely heavy weeds.

Use the High speed range for shallow cultivating, final seedbed preparation and for power composting heavy leaves, straw, mulch, or composted material. However, if the ground is very hard, you may need to use the Low speed range for better results.



### WARNING

**Before changing belt speeds, stop engine, wait for all parts to stop moving, let engine cool and disconnect spark plug wire. Remove ignition key on electric start models.**

**Failure to follow these instructions could result in personal injury.**

#### To Change from Low to High Speed:

1. Stop the engine, allow it to cool, and disconnect the spark plug wire.
2. Put Wheel Gear Lever in DISENGAGE.
3. Remove the two nuts from the plastic belt cover on top of the transmission and remove the belt cover.
4. From beneath the tiller, move the forward drive belt out of the transmission low speed groove (B, Figure 4-11) and into the high speed groove (D).

5. Pull upward on the belt to remove any slack and slip the belt out of the engine drive pulley low speed groove (A, Figure 4-11) and into the high speed groove (C).

NOTE: If the belt is difficult to move, pull on the engine start rope while pushing the belt with your finger (engine drive pulley will turn as start rope is pulled).

6. Check that the belt is within the forward belt guide (E, Figures 4-11 and 4-12) on the right-side of the unit and is within the forward idler (F, Figure 4-12) on the left-side. Be sure that the belt is situated in the center grooves (C and D, Figure 4-11) of the engine (upper) and transmission (lower) pulleys.

7. Reinstall the plastic belt cover and secure it with the two nuts.

8. Put Wheel Gear Lever in ENGAGE and reconnect spark plug wire before attempting to start the engine.

#### To Change from High to Low Speed:

1. Stop the engine, allow it to cool, and disconnect the spark plug wire.
2. Put Wheel Gear Lever in DISENGAGE.
3. Remove the two nuts from the plastic belt cover on top of the transmission and remove the belt cover.
4. From beneath the tiller, move the forward drive belt out of the transmission pulley high speed groove (D, Figure 4-11) and into the low speed groove (B).
5. Pull upward on the belt to remove any slack and slip the belt out of the engine drive pulley high speed groove (C, Figure 4-11) and into the low speed groove (A).

NOTE: If the belt is difficult to move, pull on the engine start rope while pushing the belt with your finger (engine drive pulley will turn as start rope is pulled).

6. Check that the belt is within the forward belt guide (E, Figures 4-11 and 4-12) on the right-side of the unit and is within the forward idler (F, Figure 4-12) on the left-side. Be sure that the belt is situated in the rear grooves (A and B, Figure 4-11) of the engine (upper) and transmission (lower) pulleys.

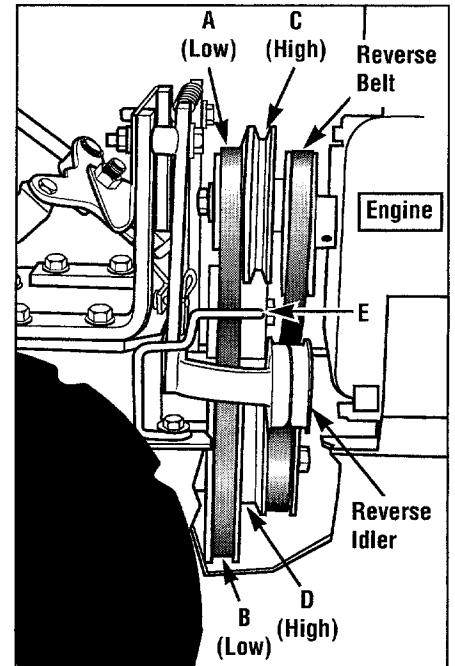

Figure 4-11: Right-side view of engine and transmission pulleys (engine is at right-side of view).

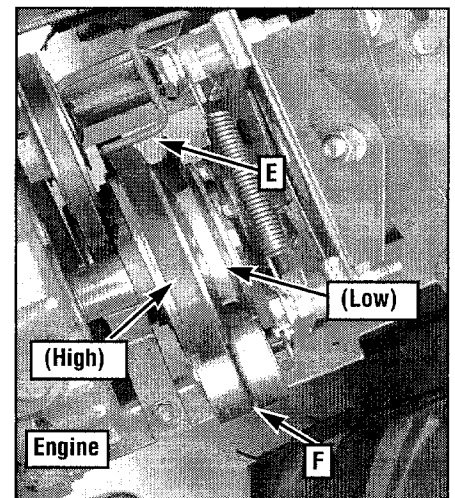
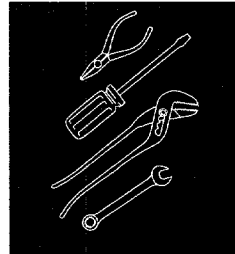

Figure 4-12: Top view of forward drive pulley system (engine is at left-side of view).

7. Reinstall the plastic belt cover and secure it with the two nuts.
8. Put the Wheel Gear Lever in ENGAGE and reconnect the spark plug wire before attempting to start the engine.

# Section 5 Maintenance



## WARNING

Before inspecting, cleaning or servicing the machine, shut off engine, wait for all moving parts to come to a complete stop, disconnect spark plug wire and move wire away from spark plug. Remove ignition key on electric start models.

Failure to follow these instructions can result in serious personal injury or property damage.

## REQUIRED MAINTENANCE SCHEDULE

| PROCEDURE   | Before Each Use | Every 10 Hours | Every 30 Hours | As Noted                    |
|---|-----------------|----------------|----------------|-----------------------------|
| Check engine oil level  | •               |                |                | And every 5 operating hours |
| Clean engine  | •               |                |                | ▲                           |
| Check drive belt tension  |                 | •              |                | †                           |
| Check nuts and bolts  |                 | •              |                | †                           |
| Change engine oil   |                 | •              |                | *                           |
| Lubricate tiller  |                 | •              |                |                             |
| Service foam pre-cleaner air filter (if so equipped)  |                 |                |                | ▲                           |
| Service paper air filter (if so equipped)   |                 |                |                | ▲                           |
| Check gear oil level in transmission  |                 |                | •              | †                           |
| Check tines for wear  |                 |                | •              |                             |
| Check air pressure in tires   |                 |                | •              |                             |
| Service spark plug  |                 |                |                | ▲                           |
| <p>* Change more frequently in dusty or dirty conditions. Change after first 2 hours of break-in operation.<br/>           † Check after first 2 hours of break-in operation.<br/>           ▲ See Engine Owner's Manual for service recommendations.</p> |                 |                |                |                             |

## Section 5: Maintenance



**WARNING** Before inspecting, cleaning or servicing the unit, shut off engine, wait for all parts to come to a complete stop, disconnect spark plug wire and move wire away from spark plug. Failure to follow these instructions can result in serious personal injury or property damage.



### TILLER LUBRICATION

Proper lubrication of the tiller is an essential part of your maintenance program. After every 10 operating hours, oil or grease the lubrication points shown in Figures 5-1 and 5-2 and described below.

Use a good quality lubricating oil (#30 weight engine oil is suitable) and a good quality general purpose grease (grease that has a metal lubricant is preferred, if available).

- Remove wheels, clean wheel shaft (A, Fig. 5-1) and apply thin coating of grease to shaft.
- Grease back, front and sides of depth regulator lever (B, Fig. 5-1).
- Remove tines, clean tine shafts (C, Fig. 5-1) and inspect for rust, rough spots or burrs (especially around holes). File or sand smooth and coat ends of shaft with grease.
- Oil the threads on the handlebar height adjustment flange screw (D, Fig. 5-1).
- Oil the outer casings of the engine throttle cable and the wheel gear cable (E, Fig. 5-1). Allow oil to soak in and then wipe off any excess.
- Oil the various pivot points (F, Fig. 5-2) on the shifting mechanism, the handlebar, and the idler arms (do not allow oil on the belts or pulleys).

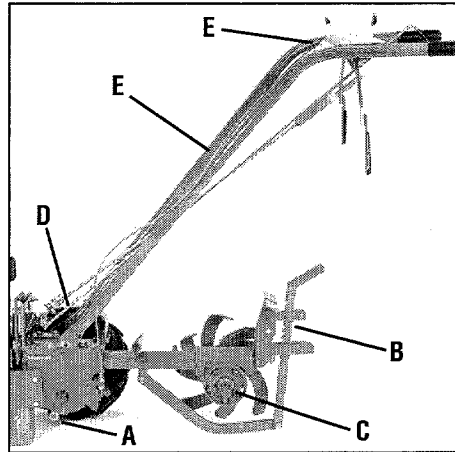

Figure 5-1

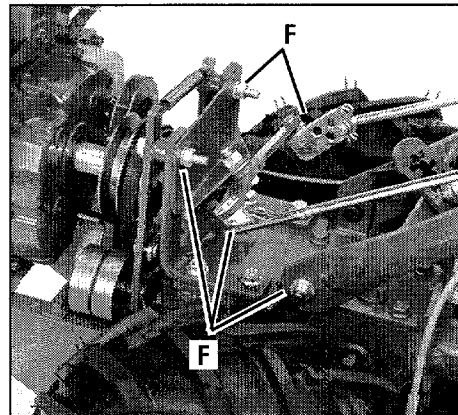

Figure 5-2

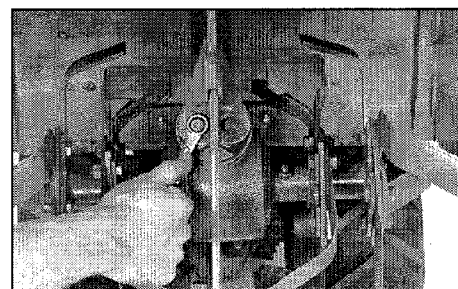

Figure 5-3

### CHECK TIRE PRESSURE

Check the **air pressure** in both tires. Deflate or inflate both tires evenly to 15-to-20 PSI (pounds per square inch). Be sure that both tires have the same air pressure or the unit will tend to pull to one side.

### CHECK FOR OIL LEAKS

Before each use, check your tiller for signs of an oil leak – usually a dirty, oily accumulation either on the unit or on the floor where it has been parked.

A little seepage around a cover or oil seal is usually not a cause for alarm. However, if the oil drips overnight then immediate attention is needed as ignoring a leak can result in severe transmission damage.

If a cover is leaking, try tightening any loose screws or bolts. If the fasteners are tight, a new gasket or oil seal may be required. If the leak is from around a shaft and oil seal, the oil seal probably needs to be replaced. See your authorized dealer or contact the factory for service or advice.

**IMPORTANT:** Never operate the tiller if the transmission is low on oil. Check the oil level after every 30 hours of operation and whenever there is any oil leakage.

### CHECK HARDWARE

At least every 10 operating hours, check the unit for loose or missing hardware (screws, bolts, nuts, hairpin cotters, etc.). Loose or missing hardware can lead to equipment failure, poor performance, or oil leaks.

Be sure to check the three end cap mounting screws located at the rear of the transmission (Figure 5-3). Lift the tine flap to service those screws.



**WARNING** Before inspecting, cleaning or servicing the unit, shut off engine, wait for all parts to come to a complete stop, disconnect spark plug wire and move wire away from spark plug. Failure to follow these instructions can result in serious personal injury or property damage.



### TRANSMISSION GEAR OIL SERVICE

Check the transmission gear oil level after every 30 hours of operation or whenever you notice any oil leak. Operating the tiller when the transmission is low on oil can result in severe damage.

#### A. To Check Transmission Gear Oil Level:

1. Check the gear oil level when the transmission is cool. Gear oil will expand in warm operating temperatures and this expansion will provide an incorrect oil level reading.
2. To check the gear oil level (and to add oil, if necessary), refer to "STEP 5: Check Gear Oil Level in Transmission" in Section 2 of this manual.

#### B. To Drain and Refill the Transmission:

The transmission gear oil does not need to be changed unless it has been contaminated with dirt, sand or metal particles.

1. Prop up the left side of the unit so that it will be securely supported when the left side wheel is removed. Remove the left side wheel by removing the wheel mounting hardware.
2. Unscrew the plastic gear oil fill plug from the top of the transmission.
3. Place a clean pan below the transmission drain plug (see Figure 5-4) and remove the drain plug. The oil will start flowing out of the drain hole (it may flow slowly, especially in cold temperatures).
4. Remove the transmission gear oil level check plug that is located a few inches above the left side wheel shaft.
5. When the oil stops flowing, tilt the transmission forward to drain oil from the rear of the transmission.
6. After draining the oil, clean the threads of the drain plug, apply a non-hardening, removable gasket sealant to the threads, and securely reinstall the drain plug.

7. Using a clean funnel, slowly add SAE 140 or SAE 85W-140 weight gear oil (with an API rating of GL-4 only) to the transmission. The transmission holds approximately 3-1/4 pints (52-54 ounces). Tilt the tiller slightly backwards to make sure the gear oil reaches the rear (tine) end of the transmission. Stop adding gear oil when it begins to flow from the oil level check hole on the side of the transmission.

8. Securely reinstall the oil level check plug.

9. Securely reinstall the gear oil fill plug on top of the transmission.

10. Remove the prop and reinstall the wheel.

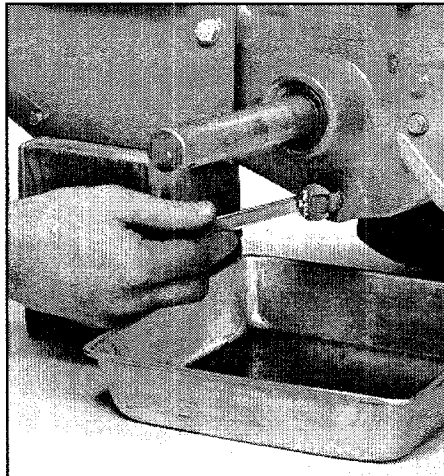

*Figure 5-4: Remove drain plug to drain transmission gear oil (also remove oil fill plug and oil level check plug).*

### ENGINE OIL SERVICE

Check the engine oil level before starting the engine each day and check it after each 5 hours of continuous operation. Running the engine when it is low on oil will quickly ruin the engine.

It is recommended that you change the motor oil after every 10 hours of operation and even sooner when operating in extremely dirty or dusty conditions.

#### A. To Check the Engine Oil Level:

1. Move the tiller to a level area and shut off the engine.
2. Level the engine by putting the Depth Regulator Lever in the second notch from the top.
3. Clean the area around the oil dipstick or oil fill tube to prevent dirt from falling into the crankcase.
4. On engines with an oil fill tube, remove the filler cap, add oil (if required) until it reaches the top of the tube and reinstall the filler cap.
5. On engines with a dipstick, remove it, wipe it clean, and reinstall it finger-tight. Remove the dipstick and check the reading. Add oil (if required) to bring the level to the FULL mark. Do not overfill.

#### B. To Change the Engine Oil:

Change the engine oil as instructed in the separate Engine Owner's Manual.

### AIR CLEANER SERVICE

The engine air cleaner filters dirt and dust out of the air before it enters the carburetor. Operating the engine with a dirty, clogged air filter can cause poor performance and damage to the engine. Never operate the engine without the air cleaner installed. Inspect and service the air cleaner more often if operating in very dusty or dirty conditions.

Service the air cleaner as instructed in the separate Engine Owner's Manual.

## Section 5: Maintenance



**WARNING** Before inspecting, cleaning or servicing the unit, shut off engine, wait for all parts to come to a complete stop, disconnect spark plug wire and move wire away from spark plug. Failure to follow these instructions can result in serious personal injury or property damage.



### SPARK PLUG SERVICE

Inspect and clean or replace the spark plug after every 100 operating hours or annually. Clean the plug and set the gap as described in the separate Engine Owner's Manual.

In some areas, local law requires using resistor spark plugs to suppress ignition signals. If the engine was originally equipped with a resistor spark plug, use the same type for replacement.

### SPARK ARRESTER SCREEN SERVICE

If the engine muffler is equipped with a spark arrester screen, remove and clean it according to the time intervals and instructions in the separate Engine Owner's Manual.

### ENGINE CLEANING

The engine must be kept clean to assure smooth operation and to prevent damage from overheating. Refer to the separate Engine Owner's Manual for specific repair and cleaning instructions. All inspections and services must be done with the engine shut off and cool to the touch.

### CARBURETOR/GOVERNOR CONTROL ADJUSTMENTS

The carburetor was adjusted at the factory for best operating speed. Refer to the separate Engine Owner's Manual for any adjustment information or see your authorized engine service dealer.

The governor controls the maximum safe operating speed and protects the engine and all moving parts from damage caused by overspeeding. Do not tamper with the engine governor settings. Seek authorized service if a problem exists.

### THROTTLE CONTROL ADJUSTMENT

If the engine does not respond to various throttle lever settings, refer to the separate Engine Owner's Manual for service information or contact your local authorized engine service dealer.



### WARNING

Operators shall not tamper with the engine governor settings on the machine; the governor controls the maximum safe operating speed to protect the engine and all moving parts from damage caused by overspeed. Authorized service shall be sought if a problem exists.

### WHEEL GEAR CABLE ADJUSTMENT

When the Wheel Gear Lever is in DISENGAGE, the wheels will roll freely (free-wheel). The wheels should not roll freely when the lever is in ENGAGE. If the wheels roll freely when the Wheel Gear Lever is in ENGAGE, the wheel gear cable needs to be adjusted as described below.

1. With the engine shut off and the spark plug wire disconnected, put the Wheel Gear Lever in ENGAGE.
2. Loosen the top adjustment nut (A, Figure 5-5) on the wheel gear cable bracket that is located on the left side rear of the transmission.
3. Push the wheel gear cable (B) down and roll the tiller slightly forward or backward until the eccentric lever (C) engages (locks) the wheels. Hold the cable in that position and tighten the top (A) and bottom (D) adjustment nuts.

4. Move the Wheel Gear Lever to ENGAGE and DISENGAGE several times to check the adjustment. The wheels should not roll when the lever is in ENGAGE, but they should roll when the lever is in DISENGAGE. Readjust the cable as required.

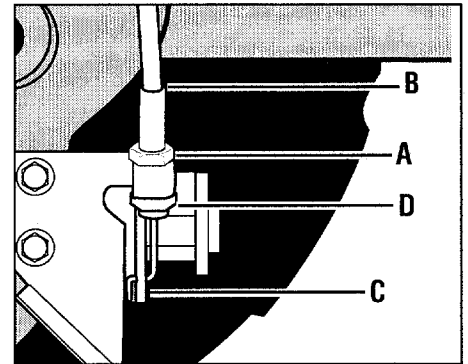

Figure 5-5: Wheel gear cable assembly.

### OFF SEASON STORAGE

When the tiller won't be used for extended periods, prepare it for storage as follows:

1. Clean the tiller and engine.
2. Do routine tiller lubrication and check for loose parts and hardware.
3. Protect the engine and perform recommended engine maintenance by following the engine storage instructions found in the separate Engine Owner's Manual. NOTE: Be sure to protect the fuel lines, carburetor and fuel tank from gum deposits by removing fuel or by treating fuel with a fuel stabilizer (follow engine manufacturer's recommendations).
4. On electric start units, follow "Battery Storage" instructions in this Section.
5. Store unit in a clean, dry area.
6. Never store the tiller with fuel in the fuel tank in an enclosed area where gas fumes could reach an open flame or spark, or where ignition sources are present (space heaters, hot water heaters, furnaces, etc.).



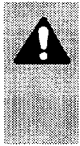

**WARNING** Before inspecting, cleaning or servicing the unit, shut off engine, wait for all parts to come to a complete stop, disconnect spark plug wire and move wire away from spark plug. Failure to follow these instructions can result in serious personal injury or property damage.

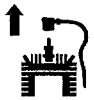

## BOLO TINES

The bolo tines will wear with use and should be inspected at the beginning of each tilling season and after every 30 operating hours. Tines can be replaced individually or as a complete set. Never inspect or service the tines unless the engine is stopped, the spark plug wire is disconnected, and the ignition key is removed on electric start models.

### A. Tine Inspection:

With use, the tines will become shorter, narrower and pointed (Figure 5-6). Badly worn tines will result in a loss of tilling depth and reduced effectiveness when chopping up and turning under organic matter. Use Figure 5-6 as a guide to when the tines should be replaced.

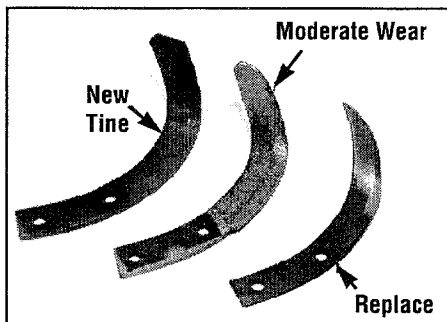

Figure 5-6: Checking tines for wear.

### B. Removing a Single Tine:

1. With the engine shut off and the spark plug wire disconnected, remove the two bolts and nuts that attach a single tine to the tine holder (Figure 5-7). If needed, use penetrating oil to help free the nuts.
2. When installing a single tine, be sure to position it so that its *cutting edge* will enter the soil first as the tiller moves forward.

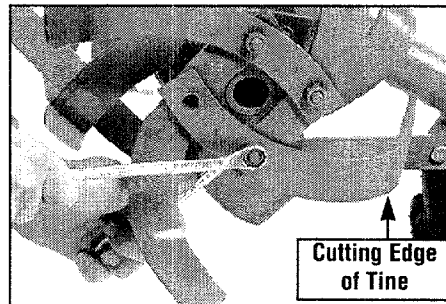

Figure 5-7: Removing single tine.

### C. Removing a Tine Assembly:

1. With the engine shut off and the spark plug wire disconnected, remove the tine hood by removing the two attaching screws at the rear of the hood and the two attaching screws at the front of the hood.
2. If removing both tine assemblies, mark them "left" and "right" before removal. Remove the screw and locknut that secure the tine assembly to the tine shaft (Photo 5-8). If necessary, use a rubber mallet to tap the tine assembly outward off the shaft.
3. Before reinstalling the tine assembly, inspect the tine shaft for rust, rough spots or burrs and file or sand as needed. Apply a thin coat of grease to the shaft.
4. Install each tine assembly so that *the cutting edge of the tines will enter the soil first when the tiller moves forward*. Secure the tine assembly to the tine shaft

using the screw and locknut previously removed. Tighten securely.

5. Replace the tine hood using the four screws previously removed. Tighten securely.

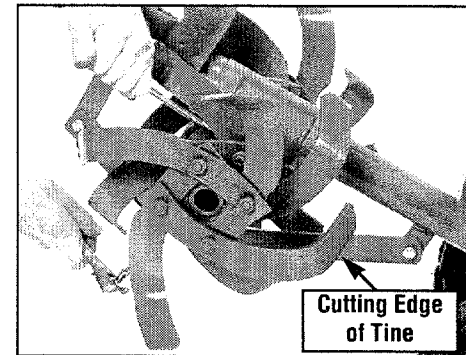

Figure 5-8: Removing a tine assembly.

## Section 5: Maintenance



**WARNING** Before inspecting, cleaning or servicing the unit, shut off engine, wait for all parts to come to a complete stop, disconnect spark plug wire and move wire away from spark plug. Failure to follow these instructions can result in serious personal injury or property damage.



### CHECKING AND ADJUSTING THE TENSION ON THE DRIVE BELTS

Maintaining correct tension on the drive belts is important to good tilling performance and long belt life. A loose belt will slip on the engine and transmission pulleys and cause the tines and wheels to slow down – or stop completely – even though the engine is running at full speed. A loose belt will also result in premature wear to the belt.

While checking belt tension, also check for cracks, cuts or frayed edges. A belt that is in poor condition should be replaced.

The tension on a new forward drive belt should be checked after the first two (2) hours of operation. Thereafter, check the tension after every ten (10) hours of operation.

The reverse drive belt, because it is used more sparingly, will probably not require an initial tension adjustment until a significant number of operating hours has passed.



### WARNING

Follow the belt adjustment instructions carefully. An incorrect adjustment could result in the Forward Clutch mechanism engaging too soon. This could cause loss of tiller control and result in personal injury or property damage.

#### To Check and Adjust Tension on the Forward Drive Belt:

1. The check for correct belt tension is the same as that described in Step 5 of “Step 4: Attach Forward Clutch Rod” on page 8. Before performing this check, shut off the engine, disconnect the spark plug wire,

and allow the engine and muffler to cool down. If, after following the adjustment procedures, you cannot get the correct gap on the forward clutch rod adjustment bracket, you will need to make a secondary adjustment as described next.

2. Disconnect the Forward Clutch Rod (A, Figure 5-9) from the swivel plate (B) by removing the innermost hairpin cotter (C).

3. Unthread the Forward Clutch Rod (in a counterclockwise direction as viewed from the front of the unit) until one or two threads on the rod extend above the rectangular nut (D, Figure 5-10) on the forward clutch bracket.

4. Remove the belt cover.

5. Slip the forward drive belt (E, Figure 5-9) out of the groove(s) in the engine driven forward drive pulley by pushing it off (away from the engine) with your left hand while pulling the engine starter rope with your right hand.

6. On the left side of the unit (as viewed from operator’s position) remove the hairpin cotter from the clevis pin (F, Figure 5-11) that connects the forward idler arm (G) to the forward adjustable link (H). Push inward on the forward idler arm (G) and remove the clevis pin (F).

7. There are two holes in the forward adjustable link (H, Figure 5-11). Push inward on the forward idler arm (G) and install the clevis pin (F) through the inner hole in the forward adjustable link (H) and out through the single hole in the forward idler arm (G). Secure the clevis pin with the hairpin cotter. NOTE: While pushing inward on the forward idler arm, be sure that the forward drive belt is moved off to the right side of the tiller. This creates more room to install the clevis pin when the forward idler arm is pushed inward.

**IMPORTANT:** With the clevis pin installed in the inner hole of the forward adjustable link, the number of additional belt tension adjustments that can be made is limited. If, with future tension adjustments, you

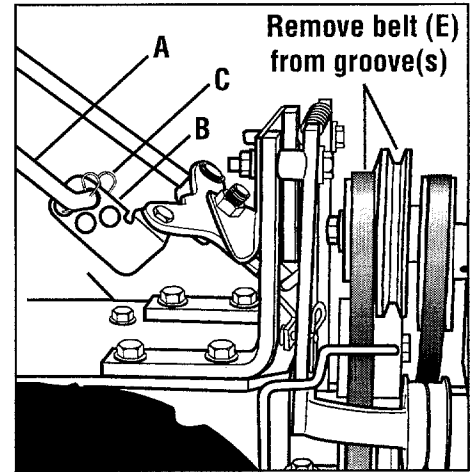

Figure 5-9: Disconnect Forward Clutch Rod and move forward drive belt out of groove(s) in engine forward drive pulley.

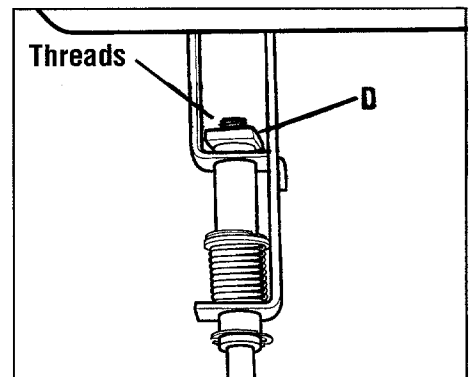

Figure 5-10: One or two threads on Forward Clutch Rod should be exposed above rectangular nut.

find that you cannot screw the forward clutch rod any farther into the rectangular nut on the forward clutch bracket, it means that the forward drive belt must be replaced. Before doing so, the clevis pin must be returned to the OUTSIDE hole in the forward adjustable link.



**WARNING** Before inspecting, cleaning or servicing the unit, shut off engine, wait for all parts to come to a complete stop, disconnect spark plug wire and move wire away from spark plug. Failure to follow these instructions can result in serious personal injury or property damage.



8. Replace the forward drive belt in the Low (or High) speed grooves of the engine drive pulley and the transmission pulley. Be sure the belt is to the inside of the wire formed belt guide (I, Figure 5-12) and to the inside of the forward drive idler pulley (J).

9. Reinstall the belt cover and secure it with the two nuts.

10. Readjust the forward drive belt tension by following the instructions in "Handlebar Height Adjustment" on Page 12.

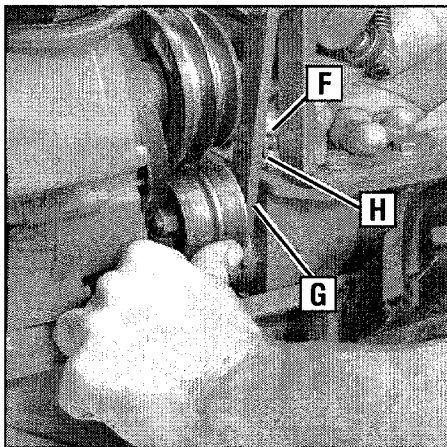

Figure 5-11: Remove clevis pin from outer hole in forward adjustable link and move to inner hole in link.

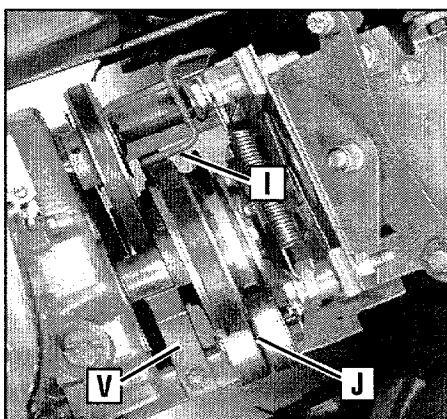

Figure 5-12: Top view of belts and pulleys.

### To Check and Adjust Tension on the Reverse Drive Belt:

1. Remove the belt cover after first shutting off the engine, disconnecting the spark plug wire, and allowing the engine and muffler to cool down.

2. Stand at the front of the tiller and use your left hand to push the reverse idler arm (K, Figure 5-13) inward as far as possible (the reverse idler pulley [L] is attached to the reverse idler arm). Hold the idler arm in this position and look at the position of the belt tension guide mark (M, Figure 5-14) that is stamped into the face of the reverse adjustable link (N, Figure 5-14).

- The belt tension is correct if the guide mark (M, Figure 5-14) is anywhere to the left of the guide pin (O), as viewed from the front of the unit (not the operator's position). If the belt tension is correct, **reinstall the belt cover and secure it with the two nuts.**
- If the guide mark is aligned with the guide pin, or moves to the right side of the guide pin, then the belt is too loose and the tension must be readjusted as described next.

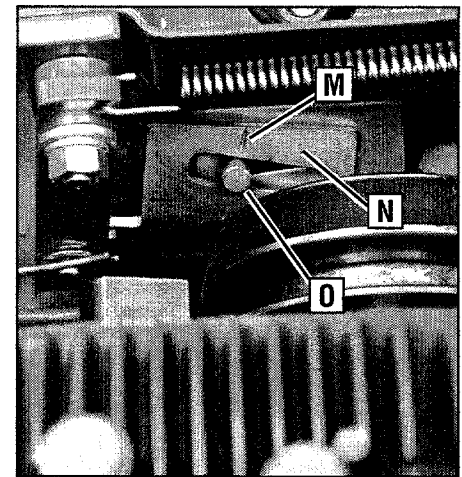

Figure 5-14: While pushing reverse idler arm inward, stand at engine end and check position of guide mark (M) and guide pin (O).

3. The reverse idler pulley (L, Figure 5-13) regulates the tension that is applied to the reverse drive belt (P). The following adjustment will allow the reverse idler pulley to apply more tension to a loose belt.

4. Remove the belt cover.

5. Slip the reverse belt (P, Figure 5-13) off the engine driven reverse (upper) pulley.

6. On the **right** side of the unit (as viewed from operator's position) remove the hairpin cotter from the clevis pin (R, Figure 5-13) that connects the reverse idler arm (K) to the reverse adjustable link. Push inward on the reverse idler arm (K) and remove the clevis pin (R).

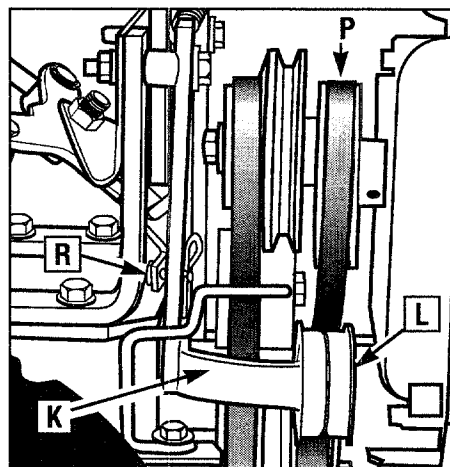

Figure 5-13: Reverse idler arm (K) and reverse pulley (L).

## Section 5: Maintenance



**WARNING** Before inspecting, cleaning or servicing the unit, shut off engine, wait for all parts to come to a complete stop, disconnect spark plug wire and move wire away from spark plug. Failure to follow these instructions can result in serious personal injury or property damage.



7. There are two holes in the reverse adjustable link (S, Figure 5-15). Push inward on the reverse idler arm (K) and install the clevis pin (R) through the **inner** hole in the reverse adjustable link (S) and out through the single hole in the reverse idler arm (K). Secure the clevis pin with the hairpin cotter.

8. Reinstall the reverse belt (P, Figure 5-13) on the reverse (upper) pulley, making sure the belt is located to the inside of the reverse idler pulley (L, Figure 5-13).

9. Reinstall the belt cover and secure it with the two nuts.

**IMPORTANT:** If, in future tests for reverse belt tension, the guide mark should again align with or move to the right side of the guide pin, it means that the reverse belt is worn beyond adjustment. Before installing a new belt, you must return the clevis pin to the **OUTSIDE** hole in the reverse adjustable link.

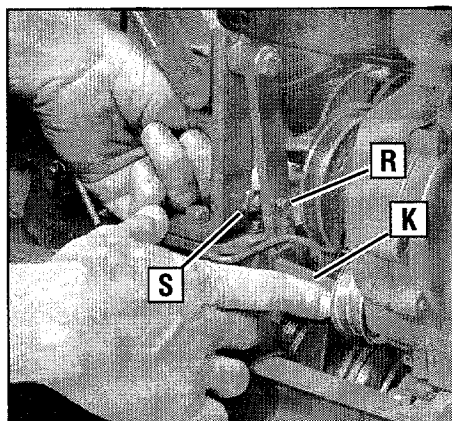

Figure 5-15: Installing clevis pin in inside hole of reverse adjustable link.

### FORWARD DRIVE BELT REMOVAL AND INSTALLATION

**NOTE:** The Econo-Horse model has two forward speeds (High and Low) and one reverse speed. The engine and transmission pulleys have two grooves for the two forward speeds and one groove for the reverse speed.

#### A. Removing the Forward Drive Belt:

1. Stop the engine, allow it to cool and disconnect the spark plug wire before working near the belts.
2. Remove the reverse drive belt (A, Figure 5-16) by following the "Removing the Reverse Drive Belt" instructions in this section.
3. Move the forward drive belt (B, Figure 5-16) into the low speed groove (rear groove) of the engine forward drive pulley.
4. Slip the forward drive belt completely off the transmission drive pulley (C, Figure 5-16) by moving it to the front of the pulley.
5. Pull the forward drive belt up and off the pulleys by feeding the bottom half of the belt in between the engine and transmission pulleys.

4. Slip the forward drive belt completely off the transmission drive pulley (C, Figure 5-16) by moving it to the front of the pulley.

5. Pull the forward drive belt up and off the pulleys by feeding the bottom half of the belt in between the engine and transmission pulleys.

#### B. Installing the Forward Drive Belt:

1. The reverse drive belt must be removed before installing the forward drive belt.
2. Slip the forward drive belt down between the rear of the engine forward drive pulley (D, Figure 5-16) and feed the bottom half in between the engine and transmission pulleys (see Figure 5-17). Be sure that the belt is to the inside of the forward idler pulley and forward belt guide (see J and I, Figure 5-12).
3. Slip the forward drive belt down and over the front of the transmission pulley (C, Figure 5-16). **NOTE:** For additional working room, loosen the reverse belt guide (V, Figure 5-12) and twist it out of the way.

4. Put the lower half of the belt into the rear groove of the transmission pulley (C, Figure 5-16).

5. Put the upper half of the belt into the groove of the engine forward drive pulley (D, Figure 5-16).

**IMPORTANT:** Make sure that the forward drive belt is to the inside of the wire belt guide (I, Figure 5-12) and the forward idler pulley (J, Figure 5-12).

6. If you loosened the belt guide, wait until the reverse drive belt is installed before securing the belt guide.

7. Install the reverse drive belt.

8. Install the belt cover and secure it with the two nuts.

9. If you installed a new belt, check the tension after two hours of operation.

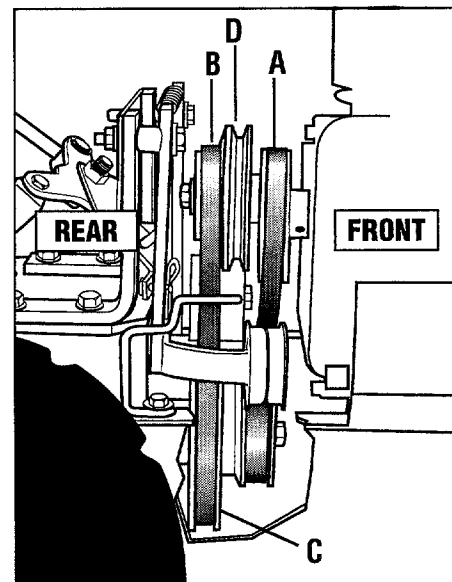
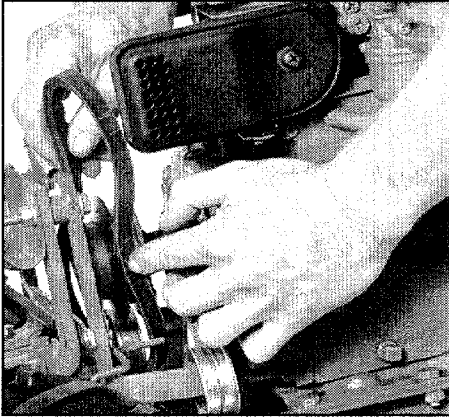

Figure 5-16: Belt drive system.



**WARNING** Before inspecting, cleaning or servicing the unit, shut off engine, wait for all parts to come to a complete stop, disconnect spark plug wire and move wire away from spark plug. Failure to follow these instructions can result in serious personal injury or property damage.



*Figure 5-17: Install forward drive belt over rear of engine forward pulley and bring lower half of belt down and in front of transmission pulley.*

### REVERSE DRIVE BELT REMOVAL AND INSTALLATION

**NOTE:** The forward drive belt must be installed before installing the reverse drive belt.

#### A. Removing the Reverse Drive Belt:

1. Stop the engine and allow it to cool before working near the belts. Be sure the spark plug wire is disconnected and on electric start models the ignition key is removed.
2. Remove the belt cover by removing the two nuts. For easier access to the transmission (lower) pulley, remove the transmission cover located below the transmission pulley.
3. Slip the reverse belt off the engine reverse pulley (A, Figure 5-18). If necessary, work the belt off the pulley with your left hand while pulling the engine recoil starter rope with your right hand.
4. Push the upper half of the reverse belt downward to create slack in the belt. Then reach underneath the transmission and slip the belt off the front of the transmission pulley (B, Figure 5-18).

5. Pull the belt up and past the engine reverse pulley (A, Figure 5-18).

#### B. Installing the Reverse Drive Belt:

1. Slip the reverse belt down between the engine reverse pulley (A, Figure 5-18) and the engine forward drive pulley (C).
2. Loop the bottom half of the belt over the front of the transmission pulley (B, Figure 5-18) and seat the belt in the front groove of the pulley.
3. Place the belt to the inside of the reverse idler pulley (D, Figure 5-18) and the reverse belt guide (V, Figure 5-12). Then slip the upper end into the groove of the engine reverse pulley (A, Figure 5-18).
4. If the reverse belt guide (V, Figure 5-12) was loosened previously, center the belt guide on the belt and tighten the mounting screw securely.
5. Install the belt cover and secure it with the two nuts. If the lower transmission cover was removed, reinstall it with the four self-tapping screws.

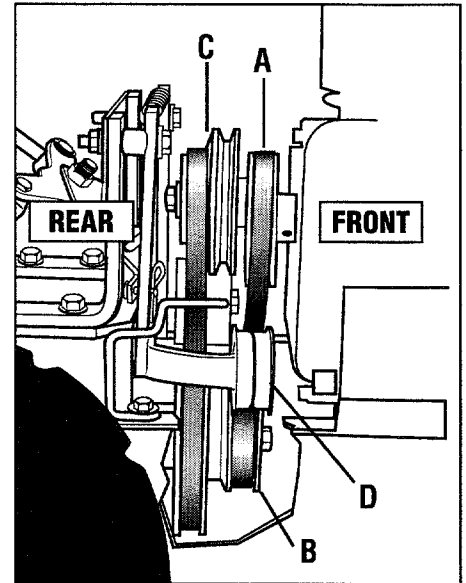

*Figure 5-18: Removing and installing reverse belt.*

## TROUBLESHOOTING

Before performing any corrections, refer to the appropriate information in this Manual, or in the Engine Owner's Manual, for the correct safety precautions and operating or maintenance procedures. Contact your local authorized Engine Service Dealer for engine service. Contact your local authorized equipment dealer or the factory for all other service problems.

| PROBLEM                                | POSSIBLE CAUSE   | CORRECTION  |
|--|--|---|
| <b>Engine does not start.</b>          | <ol style="list-style-type: none"> <li>1. Spark plug wire disconnected.</li> <li>2. Engine Throttle Control Lever incorrectly set.</li> <li>3. Fuel tank empty.</li> <li>4. Choke control (if so equipped) in incorrect position.</li> <li>5. Stale gasoline.</li> <li>6. Dirty air filter(s).</li> <li>7. Defective or incorrectly gapped spark plug.</li> <li>8. Carburetor out of adjustment.</li> <li>9. Misadjusted throttle control cable.</li> <li>10. Dirt or water in fuel tank.</li> </ol> | <ol style="list-style-type: none"> <li>1. Reconnect wire.</li> <li>2. Put lever in START position.</li> <li>3. Add fuel.</li> <li>4. See Engine Owner's Manual.</li> <li>5. Drain fuel and add fresh fuel.</li> <li>6. Clean or replace filter(s).</li> <li>7. Inspect spark plug.</li> <li>8. See Engine Service Dealer.</li> <li>9. See Engine Service Dealer.</li> <li>10. See Engine Service Dealer.</li> </ol> |
| <b>Engine runs poorly.</b>             | <ol style="list-style-type: none"> <li>1. Defective or incorrectly gapped spark plug.</li> <li>2. Dirty air filter(s).</li> <li>3. Carburetor out of adjustment.</li> <li>4. Stale gasoline.</li> <li>5. Dirt or water in fuel tank.</li> <li>6. Engine cooling system clogged.</li> </ol>   | <ol style="list-style-type: none"> <li>1. Inspect spark plug (see Engine Owner's Manual).</li> <li>2. Clean or replace (see Engine Owner's Manual).</li> <li>3. See Engine Service Dealer.</li> <li>4. Replace with fresh gasoline.</li> <li>5. See Engine Service Dealer.</li> <li>6. Clean air cooling system (see Engine Owner's Manual).</li> </ol>   |
| <b>Engine overheats.</b>               | <ol style="list-style-type: none"> <li>1. Engine cooling system clogged.</li> <li>2. Carburetor out of adjustment.</li> <li>3. Oil level is low.</li> </ol>  | <ol style="list-style-type: none"> <li>1. Clean air cooling area (see Engine Owner's Manual).</li> <li>2. See Engine Service Dealer.</li> <li>3. Check oil level (see Engine Owner's Manual).</li> </ol>  |
| <b>Engine does not shut off.</b>       | <ol style="list-style-type: none"> <li>1. Misadjusted throttle control cable.</li> </ol>   | <ol style="list-style-type: none"> <li>1. See Engine Owner's Manual or Engine Service Dealer.</li> </ol>  |
| <b>Wheels and Tines will not turn.</b> | <ol style="list-style-type: none"> <li>1. Improper use of controls.</li> <li>2. Forward Drive: Misadjusted forward clutch rod.</li> <li>3. Reverse Drive: Broken or misadjusted belt.</li> <li>4. Worn, broken, or misadjusted drive belt(s).</li> <li>5. Internal transmission wear or damage.</li> <li>6. Bolt and key loose in transmission pulley.</li> </ol>  | <ol style="list-style-type: none"> <li>1. Review Sections 3 and 4.</li> <li>2. See "Handlebar Height Adjustment," Section 3.</li> <li>3. Replace belt or adjust belt tension (Section 5).</li> <li>4. See "Checking Drive Belt Tension," Section 5.</li> <li>5. Contact local dealer or the factory.</li> <li>6. Tighten bolt; check that key is in place.</li> </ol>   |
| <b>Tines turn, but wheels don't.</b>   | <ol style="list-style-type: none"> <li>1. Wheel mounting hardware missing.</li> <li>2. Bolt and key loose in transmission pulley.</li> <li>3. Internal transmission wear or damage.</li> <li>4. Misadjusted wheel gear cable.</li> <li>5. Wheel Gear Lever not fully engaged.</li> </ol>   | <ol style="list-style-type: none"> <li>1. Replace hardware.</li> <li>2. Tighten bolt; check that key is in place.</li> <li>3. Contact local Dealer or the Factory.</li> <li>4. See "Wheel Gear Cable Adjustment," Section 5.</li> <li>5. Engage lever (see Section 3).</li> </ol>   |
| <b>Wheels Turn, but Tines Don't.</b>   | <ol style="list-style-type: none"> <li>1. Tine holder mounting hardware missing.</li> <li>2. Internal transmission wear or damage.</li> </ol>  | <ol style="list-style-type: none"> <li>1. Replace hardware.</li> <li>2. Contact local Dealer or the Factory.</li> </ol>   |
| <b>Poor tilling performance.</b>       | <ol style="list-style-type: none"> <li>1. Worn tines.</li> <li>2. Improper Depth Regulator setting.</li> <li>3. Incorrect throttle setting or belt range speed.</li> <li>4. Belt(s) slipping.</li> </ol>   | <ol style="list-style-type: none"> <li>1. See "Bolo Tines" (Section 5).</li> <li>2. See "Tilling Tips &amp; Techniques," Section 4.</li> <li>3. See Section 4.</li> <li>4. See "Checking Drive Belt Tension," Section 5.</li> </ol>   |

# TILLER SPECIFICATIONS/ATTACHMENTS

## TILLER SPECIFICATIONS

### TILLER HEIGHT (with Depth Regulator Lever in highest setting):

|                                     |         |
|-------------------------------------|---------|
| Without Handlebars .....            | 22-3/4" |
| Handlebars in lowest setting.....   | 39-1/2" |
| Handlebars in highest setting ..... | 48-3/4" |

### TILLER LENGTH

|                                   |         |
|-----------------------------------|---------|
| Without Handlebars .....          | 45-1/2" |
| Handlebars in lowest setting..... | 66-1/2" |

### TILLER WIDTH

|                       |         |
|-----------------------|---------|
| Hood Width .....      | 20"     |
| Tilling Width .....   | 18"     |
| Wheel Width .....     | 18-1/2" |
| Handlebar Width ..... | 20-1/4" |

### TILLER WEIGHT

|   |          |
|---|----------|
| Approximate Weight (without oil or gas) ..... | 205 lbs. |
|---|----------|

### TRANSMISSION GEAR OIL SPECIFICATIONS

For small top-offs: Use SAE 140, SAE 85W-140, or SAE 80W-90 gear oil with an API rating of either GL-4 or GL-5.

For Full Replacement: Use SAE 140 or SAE 85W-140 gear oil with API rating of GL-4 (do not use GL-5).

## TILLER ATTACHMENTS

The attachments listed below are available for your tiller. The information is the most current at the time this manual was printed. Contact your authorized dealer or the factory for current information.

### BUMPER

A tubular steel bumper surrounds the engine to protect the air cleaner, starter assembly and fuel tank from damage.

### HILLER/FURROWER

The furrower blade attaches to the back of the depth regulator assembly and is used to create rows, trenches and ditches up to 8" deep, depending on soil conditions. The two hiller wings attach to the sides of the furrower blade and are used to make hilled rows and raised bed gardens.

### ROW MARKER

The row marker attaches to the hiller/furrower attachment and is used to scratch lines in the seedbed for laying out furrows, trenches, raised beds, etc. (eliminates the need for stakes, string and measuring tape). The row marker is adjustable in length from 28" to 49-3/4", allowing you to vary the width of the marked rows as required.

# CUSTOMER SERVICE INFORMATION

## Owner Registration Card

Please fill out and mail the enclosed owner registration card. The purpose of this card is to register each unit at the factory in order to keep the owner informed with informational bulletins and safety literature.

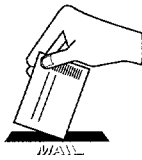

## Warranty Service

The warranty statement is included in the unit's literature package.

## Model/Serial Numbers

A Model/Serial Numbers decal is located on top of the transmission (see figure below). For ready reference, record these numbers in the spaces below.

**Date of purchase:**

---

**Model/Serial Numbers:**

---

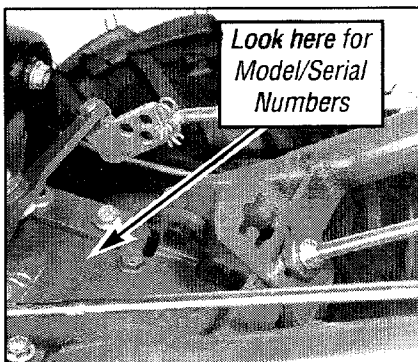

## Customer Service and Technical Service

If you have questions or problems with the unit, contact your local dealer or call or write to the factory. (When calling or writing the factory, provide the model/serial number of the unit.)

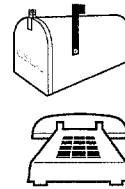

## Replacement Parts

Factory specified replacement parts are available from your authorized dealer or directly from the factory. For parts ordering information, refer to the parts catalog.

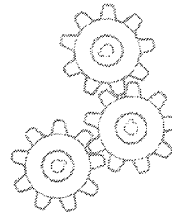

## Engine Service and Repair

For engine service or repair, contact your nearest authorized engine dealer (look in the Yellow Pages under "Engines-Gasoline"). The engine is warranted by the engine manufacturer. Any unauthorized work performed on the engine during the warranty period may void this warranty. For complete details on the engine warranty, refer to the engine owner manual.

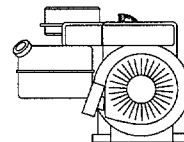

## Authorized Dealer Information

If you purchased your unit from an authorized dealer, record the dealer's address and phone number below for ready reference:

**Dealer Name:** \_\_\_\_\_

**Address:** \_\_\_\_\_

**Phone:** \_\_\_\_\_

**For customer assistance, contact your nearest authorized dealer or:**

**GARDEN WAY INCORPORATED** • 1 Garden Way • Troy, New York 12180

Customer Service: 1-800-437-8686 • Technical Service: 1-800-520-5520 • Parts Service: 1-800-648-6776

• FAX: (518) 391-7332 • WEBSITE: [www.troybilt.com](http://www.troybilt.com)

Outside the United States and Canada:

Customer Service: (518) 391-7007 • Technical Service: (518) 391-7008 • Parts Service: (518) 391-7006 • FAX: (518) 391-7332