

\$4⁵⁰



Owner/Operator Manual

TUFFY[®] Tiller

- Safety
- Assembly
- Features and Controls
- Operation
- Maintenance

Models

12155

12163 *Bullock*

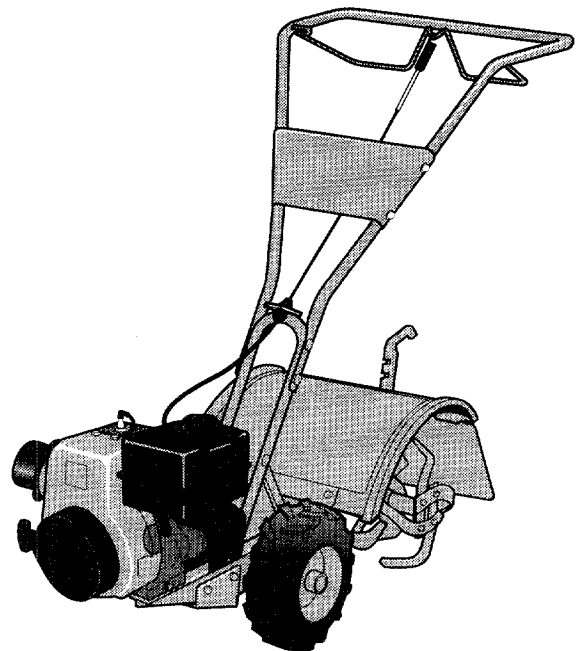

Dear Owner,

You now own one of the finest rear-tine rototillers available. Your new TUFFY® Model tiller allows you to till and cultivate your garden with ease, and accomplish dozens of other property management projects as well. Your tiller is famous for its ruggedness, performance and high-quality engineering. We know you'll enjoy using it.

Please carefully read this Manual. It tells you how to safely and easily assemble, operate and maintain your machine. *Be sure that you and any other operators carefully follow the recommended safety practices at all times. Failure to do so could result in personal injury or property damage.*

Of course, if you should ever have any problems or questions, or for a replacement copy of this Manual, please contact your local authorized service dealer or call us Toll-Free. Our telephone numbers and mailing addresses are listed on Page 4 and on the back cover of this Manual.

We want to be sure that you are completely satisfied at all times.

This machine meets voluntary safety standard B71.8 – 1996, which is sponsored by the Outdoor Power Equipment Institute, Inc., and is published by the American National Standards Institute.



This is a safety alert symbol. It is used in this Owner/Operator Manual to alert you to potential hazards. Whenever you see this symbol, read and obey the safety message that follows it. Failure to obey the safety message could result in personal injury or property damage.

Be Sure To Return Your Warranty Registration Card

Be sure to fill out and mail your Warranty Registration Card, which is located in your literature package. The information contained on this card will register your machine with us and entitle you to warranty coverage.

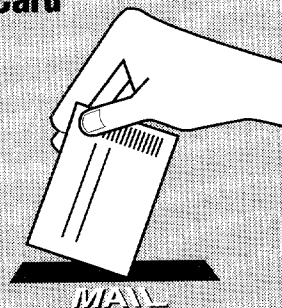

WARNING:

The engine exhaust from this product contains chemicals known to the State of California to cause cancer, birth defects, or other reproductive harm.

Owner's Record

Please write the Model and Serial numbers of your machine in the spaces provided. You can find the location of these numbers by referring to the illustration below.

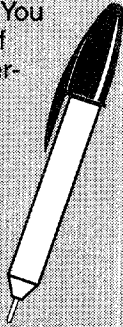

Model Number:

Serial Number:

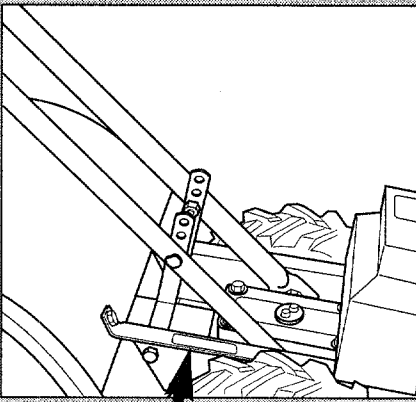

Model and Serial Number location

Table of Contents

SERVICE INFORMATION	4
SECTION 1: SAFETY	5
Training	5
Preparation	6
Operation	6
Maintenance and Storage	7
Decals	7
SECTION 2: ASSEMBLY	8
SECTION 3: FEATURES AND CONTROLS	12
Tiller Features and Controls Identification	12
Engine Features and Controls Identification	14
SECTION 4: OPERATION	15
Break-In Operation	15
Pre-Start Checklist	16
Starting and Stopping the Engine	16-17
Tilling Depths	17
Guiding the Tiller	17
Moving the Tiller Forward	17
Moving the Tiller Rearward	17
Turning the Tiller Around	18
Tilling in the Garden	18
Seedbed Preparation	18
Cultivating	19
Power Composting	19
High-Traction Frame Weights	19
Preventing Tines from Becoming Tangled	20
Tilling on Slopes	20
Terrace Gardening	20
Loading and Unloading the Tiller	21
SECTION 5: MAINTENANCE & REPAIRS	22
Required Maintenance Schedule	22
Regular Maintenance	23
Tiller Lubrication	23
Checking and Adding Engine Oil	23
Changing Engine Oil	24
Checking and Topping Off Transmission Gear Oil	24
Changing Transmission Gear Oil	25
Checking for Oil Leaks	26
Air Cleaner Maintenance	26
Engine Cooling System Maintenance	26
Engine Ignition System Maintenance	26
Spark Plug Maintenance	26
Carburetor Adjustments	26
Tightening Tiller Hardware	27
Bolo Tines	27
Removing and Installing Tine Assemblies	27
Removing and Installing Individual Tines	27
Checking and Adjusting Belt Tension	28
Belt Removal and Replacement	28
Forward Clutch Bail Replacement	29
Removing and Installing the Forward Clutch Cable	29
Tiller Storage	30
TROUBLESHOOTING	31
TILLER & ENGINE SPECIFICATIONS	32
INDEX	33

We're at Your Service!

HOW TO REACH US

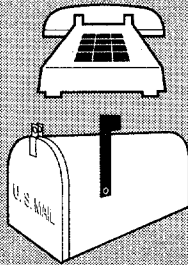

Address

GARDEN WAY INCORPORATED,
1 Garden Way
Troy, New York
12180
U. S. A.

Telephone Numbers

**U.S.A.
and Canada**
(Toll Free)

Customer Service:
1-800-437-8686

Technical Service:
1-800-520-5520

Parts Service:
1-800-648-6776

FAX:
(518) 391-7332

**Outside the
U.S.A. and
Canada**

Customer Service:
(518) 391-7007

Technical Service:
(518) 391-7008

Parts Service:
(518) 391-7006

FAX:
(518) 391-7332



If you have any Questions or Problems...

...Please contact your local tiller authorized dealer or call or write the Factory. When calling or writing, please be sure to provide the Model and Serial Numbers of your machine (refer to Page 3).

If You Need Engine Service:

If your engine should ever require service or repair, contact your nearest authorized engine service dealer.

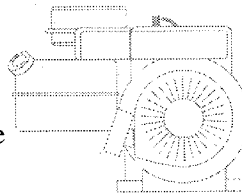

To find the name and address of your nearest authorized engine service dealer, look in the Yellow Pages of the telephone book under

“Engines-Gasoline” (call us if you need assistance in obtaining engine service or parts).

Please remember that your engine is covered by the engine manufacturer's Limited Warranty. Any unauthorized work performed on the engine during the warranty period may void the warranty. For full details on the engine manufacturer's Limited Warranty, refer to the separate Engine Owner's Manual.

If You Need Parts:

Factory specified replacement parts for your machine are available from either your tiller authorized dealer or directly from the Factory.

To order a part from the Factory, refer to your separate Parts Catalog to find the part

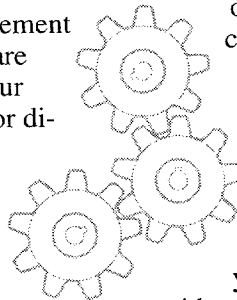

number, description, and quantity of the part you need. Then, call or write our Parts

Department, being sure to provide the Model and Serial Numbers of your machine.

Our trained parts specialists will gladly assist you if you have any difficulty in identifying the part that you need.

Section

1 Safety

Read Me First!

Please read and follow all of the safety rules in this Safety Section. Failure to comply could result in serious personal injury or property damage.

If you should lend this equipment to another person, make sure that he or she reads, understands, and always follows these safety instructions.

If you are not completely sure about any of the information found here or elsewhere in the Manual, please contact either your local authorized dealer or the factory for assistance.



This is a safety alert symbol. It is used in this Owner/Operator Manual and on your equipment to alert you to potential hazards.

Whenever you see this symbol, read and obey the safety message that follows it. Failure to obey those safety messages could result in serious personal injury or cause property damage.

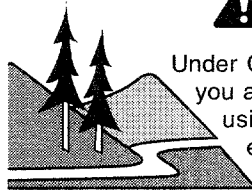

WARNING TO ALL CALIFORNIA AND OTHER POWER EQUIPMENT OPERATORS

Under California law, and under the laws of several other states, you are not permitted to operate an internal combustion engine using hydrocarbon fuels on any forest-covered, brush-covered, or grass-covered land, or on land covered with grain, hay, or other flammable agricultural crop, without an engine spark arrester in continuous effective working order.

The engine on your power equipment, like most outdoor power equipment, is an internal combustion engine that burns gasoline, a hydrocarbon fuel. Therefore, your power equipment must be equipped with a spark arrester muffler in continuous effective working order. The spark arrester must be attached to the engine exhaust system in such a manner that flames or heat from the system will not ignite flammable material. Failure of the owner/operator of the equipment to comply with this regulation is a misdemeanor under California law, and may also be a violation of other state and/or federal regulations, laws, ordinances, or codes. Contact your local fire marshal or forest service for specific information about what regulations apply in your area. Contact your authorized engine dealer for information about obtaining a spark arrester.

TRAINING



1. Read this Owner/Operator Manual and the separate Engine Owner's Manual carefully before operating this equipment. Be completely familiar with the controls and the proper use of this equipment. Know how to stop the unit and disengage the controls quickly.
2. Never allow children or untrained adults to operate this equipment.
3. Keep the area of operation clear of all persons, particularly small children and pets. Keep bystanders at least 25 feet away from the area of operation.



4. Keep in mind that the operator or user is responsible for accidents or hazards occurring to other people, their property, and themselves.

5. Familiarize yourself with all of the safety and operating decals on this equipment and on any of its attachments or accessories.

6. Do not run engine in an enclosed area. Engine exhaust contains carbon monoxide gas, a deadly poison that is odorless, colorless, and tasteless. Do not operate this equipment near buildings, windows, or air conditioners.

7. Do not allow hands or any other part of the body or clothing near the rotating tines or near any other moving part. The tines begin to rotate forward once the engine starts and the Forward Clutch Bail is engaged.



Safety

8. Before inspecting or servicing any part of the equipment, shut off the engine, wait for all moving parts to come to a complete stop, disconnect the spark plug wire

from the spark plug and move wire away from the spark plug.

alcohol, medication, or when you are tired or ill.

9. Do not operate this equipment if you are under the influence of

PREPARATION

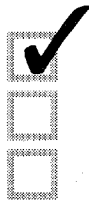

1. Thoroughly inspect the area where the tiller will be used. Remove foreign objects before tilling.
2. Make sure that all control levers are released and both wheels are in Wheel Drive position before starting the engine.
3. Do not operate the tiller without wearing suitable clothing. Avoid loose garments or jewelry that could get caught in moving parts of the tiller or its engine.
4. Do not operate the tiller when you are barefoot, in sandals, sneaker

ers or other light footwear. Wear protective footwear that grips well on slippery surfaces.

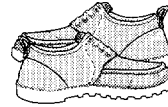

5. Do not till near underground electric cables, telephone lines, pipes, or hoses. Contact your telephone or utility to verify locations of underground cables or lines.

6. Handle gasoline with care; it is highly flammable, and has explosive vapors. Take the following precautions:

- a. Use an approved gas container.
- b. Gas caps shall never be removed or fuel added with engine running. Engine shall be allowed to cool before refueling. Operators shall not smoke.

- c. Keep matches, cigarettes, cigars, pipes, open flames, or sparks away from the fuel tank and fuel container.
 - d. Fill fuel tank outdoors using extreme caution. Never add fuel indoors. Use a funnel or spout to prevent spillage.
 - e. Replace all fuel tank and container caps securely.
 - f. If fuel is spilled, do not attempt to start the engine, but move the machine away from the area of spillage and avoid creating any source of ignition until fuel vapors have dissipated.
7. Never attempt to make any adjustments while the engine is running or the spark plug wire is connected, except when so instructed.

OPERATION



1. Do not put hands or feet near or under rotating parts.
2. Use extreme caution when on or crossing gravel driveways, walks or roads. Be alert for hidden hazards or traffic. Do not carry passengers.
3. If you hit a foreign object, stop the engine, let all moving parts come to a complete stop, disconnect spark plug wire, move wire away from the spark plug, and inspect for damage. Repair damage before restarting.
4. Exercise caution to avoid slipping or falling.

5. If abnormal tiller vibration occurs, stop engine immediately, disconnect the spark plug wire and move wire away from spark plug. Check for the cause.

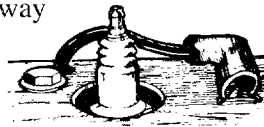

Carefully inspect for any damage. Fix the problem before using the tiller again. Vibration is generally a warning sign trouble.

6. Stop the engine, disconnect the spark plug wire and move wire away from spark plug before leaving the operating position, unclogging tines, or making repairs, adjustments or inspections.

7. Take all possible precautions before leaving the machine unattended. Make sure that all control levers are released, stop engine, and disconnect spark plug wire and move wire away from plug to prevent accidental starting. Be sure both wheels are in the WHEEL DRIVE position.

8. Before cleaning, repairing or inspecting, stop the engine, let all moving parts stop, and disconnect spark plug wire and move wire away from spark plug to prevent accidental starting.

9. The flap on the tine hood must be down when operating tiller.

10. Never operate the tiller unless safety guards or other protective devices are in place.

11. Do not run the engine in an enclosed area. Engine exhaust contains carbon monoxide gas, a deadly poison that is odorless, colorless, and tasteless.

12. Keep children and pets away.

13. Never operate the tiller under engine power if the wheels are in the FREEWHEEL position. In FREEWHEEL, the wheels will not hold the tiller back and the revolving tines could propel the tiller rapidly, possibly causing loss of control. Always engage the wheels with the Wheel Drive Pins

in WHEEL DRIVE position before starting the engine or engaging the tines with the Forward Clutch Bail.

14. The tiller could unexpectedly bounce upward or jump forward and be propelled away from you if the tines strike or catch very hard-packed soil, sod, frozen ground, or any buried obstacle such as large stones or roots. If in doubt about tilling conditions, use the following precautions to assist you in maintaining tiller control:

- a. Walk behind and on either side of the tiller, using one hand on the handlebars. Relax your arm, but use a secure hand grip.
- b. Use shallow depth regulator settings, gradually working deeper with each tilling pass.
- c. Use slower engine speeds.
- d. Clear the tilling area of big stones, roots and other debris.
- e. Avoid putting downward pressure on the handlebars. If necessary, apply slight upward pressure to prevent the tines from digging too deeply.
- f. Avoid contacting hard-packed soil or sod at the end of a row by reducing engine speed and

lifting handlebars up to raise tines out of the soil.

- g. In an emergency, stop tines and wheels by releasing the Forward Clutch Bail. Do not attempt to restrain the tiller.
- 15.** Do not overload the machine capacity by trying to till too deeply at too fast a rate.
- 16.** Never use the tiller at high ground speeds on hard or slippery surfaces. Look behind and use caution when backing up.
- 17.** Do not operate tiller on a slope too steep for safety. On slopes, slow down and be sure you have good footing. Don't let the tiller "freewheel" down slopes.
- 18.** Clear the area of bystanders before tilling.
- 19.** Use only attachments and accessories approved by Garden Way Incorporated.
- 20.** Use tiller attachments and accessories when recommended.
- 21.** Never operate the tiller without good visibility or light.
- 22.** Never operate the tiller if you are fatigued, or under the influence of alcohol, drugs or medication.

23. Operators shall not tamper with the engine-governor settings on the machine; the governor controls the maximum safe operating speed and protects the engine and all moving parts from damage caused by over-speed. Authorized service shall be sought if a problem exists.

24. Do not touch engine parts that may be hot from operation (muffler, fins, etc.). Make certain *all* parts have cooled down before inspecting, cleaning or repairing.

25. Remember—To stop the tines and wheels, release the Forward Clutch Bail.

26. Look behind and exercise caution when backing up.

27. To load or unload the tiller from a vehicle, see complete instructions in Section 4.

28. Use extreme caution when reversing or pulling the machine towards you.

29. Start the engine carefully according to instructions and with feet well away from the tines.

30. Never pick up or carry a machine while the engine is running.

MAINTENANCE AND STORAGE

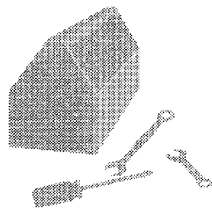

- 1.** Never perform maintenance when engine is running or spark plug wire is connected except when specifically directed to do so.
- 2.** Keep tiller, attachments and accessories in safe working condition.
- 3.** Check all nuts, bolts, and screws frequently for proper tightness.

Always verify your equipment is in safe working condition.

- 4.** Never store the machine with fuel in the fuel tank inside a building where fumes may reach an open flame or spark, or where ignition sources are present (such as hot water and space heaters, furnaces, clothes dryers, etc.).
- 5.** Let the engine cool down before storing it in an enclosure.
- 6.** To reduce fire hazard possibilities, keep the engine free of grass, leaves or grease.

7. Store gasoline in a cool, well-ventilated area, safely away from any spark- or flame-producing equipment. Store gasoline in an approved container, safely out of the reach of children.

8. Refer to the Maintenance section in this Manual for storage information if your tiller is to be stored for an extended period.

9. If the fuel tank has to be drained, do so outdoors.

10. Follow manufacturer's recommendations for safe loading, unloading, transport, and storage of machine.

SAFETY DECALS

Make certain that all safety decals on this equipment are kept clean and in good condition. There are other decals located on your equipment for operation and

controls identification. If you need a replacement decal, please refer to the Parts Catalog that accompanied this Manual.

Section

2

Assembly

Read Me First!

Please carefully follow the steps in this Section to properly assemble your new machine. These steps will not take very long and they will assure you of having assembled your machine correctly.



WARNING

To prevent personal injury or property damage, do not attempt to start the engine until all assembly steps are complete and you have read and understand the safety and operating instructions in this Manual.

Tools Needed:

One 3/8" Open End or Adjustable Wrench

Two 7/16" Open End or Adjustable Wrenches

One 1/2" Open End or Adjustable Wrench

Two 9/16" Open End or Adjustable Wrenches

Funnel (to add oil)

Rag (to clean up any spilled oil)

Block of Wood (to support tiller when removing wheel)

Ruler (for belt tension check)

1. Package Inspection

Inspect carton and its contents upon delivery for evidence of damage.

If you find or suspect any damage, contact the carrier (trucking company) immediately. Inform them of the specific damage and that you wish to file a claim. To protect your rights, be sure to put this in writing to the carrier within 15 days after your machine arrives. The carrier will let you know how to proceed with your claim. Please let us know if you need any assistance with this matter.

2. Package Contents

NOTE: Wait until you have assembled the handlebars before moving the tiller off the shipping platform.

Carefully unpack the carton and check that you have received the items listed below. If any items are missing or damaged, please contact us for replacements.

- Tiller/Engine Assembly
- Handlebar Support (see A, Fig. 2-2).
- Handlebar Assembly (see L, Fig. 2-2).
- Handlebar Panel (see K, Fig. 2-2).
- Hardware bag – includes:

NOTE: Use screw length template (Fig. 2-1) to identify screws.

- (1) Slotted hd. screw, #10-24 x 2" long
- (6) Curved head screws, 5/16"-18 x 1-1/2" long
- (1) Hex hd. screw, 1/4"-20 x 1-1/4" long
- (2) Hex hd. screws, 3/8"-16 x 3/4" long
- (4) Hex hd. self-threading screws, 1/4"-20 x 1/2" long
- (2) Flat washers, 3/8"
- (6) Split Lockwashers, 5/16"
- (1) Hex locknut, 1/4"-20
- (6) Hex nuts, 5/16"-18
- (2) Hex locknuts, 3/8"-16
- (1) Cable spring
- (1) Cable bracket (see R, Fig. 2-4).

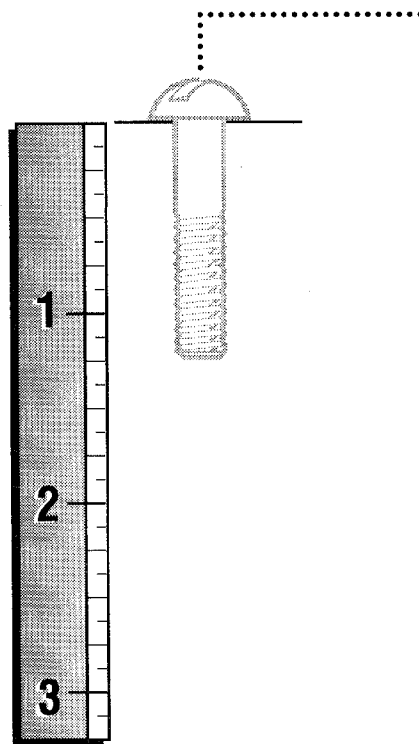

FIG. 2-1. Place screw on top of template and measure distance between bottom of screw head and tip of screw.

IMPORTANT: Motor oil must be added to the engine before it is started! The oil filling procedure is explained in Step 7.

NOTE: "LEFT" and "RIGHT" sides of tiller are as viewed from the operator's position behind the handlebars.

3. Attach the Handlebar

1. Attach the legs of the handlebar support (A, Fig. 2-2) loosely to the inner sides of the tiller frame using two 3/8"-16 x 3/4" hex hd. screws (B), 3/8" flat washers (C) and 3/8"-16 hex locknuts (D).

2. Using the middle holes in the handlebar support brackets (E and F, Fig. 2-2), loosely attach the support brackets to the handlebar support (A) using two 5/16"-18 x 1-1/2" curved hd. screws (G), 5/16" split lockwashers (H) and 5/16"-18 hex nuts (I). NOTE: If a support bracket will not move, loosen attaching screw (J) and nut.

3. Attach the handlebar panel (K, Fig. 2-2) to the handlebar assembly (L) using four 1/4"-20 x 1/2" self-threading screws (M). Tighten the four screws securely.

4. Attach the handlebar assembly (L) to the handlebar support (A) using four 5/16"-18 x 1-1/2" curved hd. screws (G), 5/16" split lockwashers (H) and 5/16"-18 hex nuts (I). Tighten the four screws securely.

5. Tighten all handlebar mounting hardware securely.

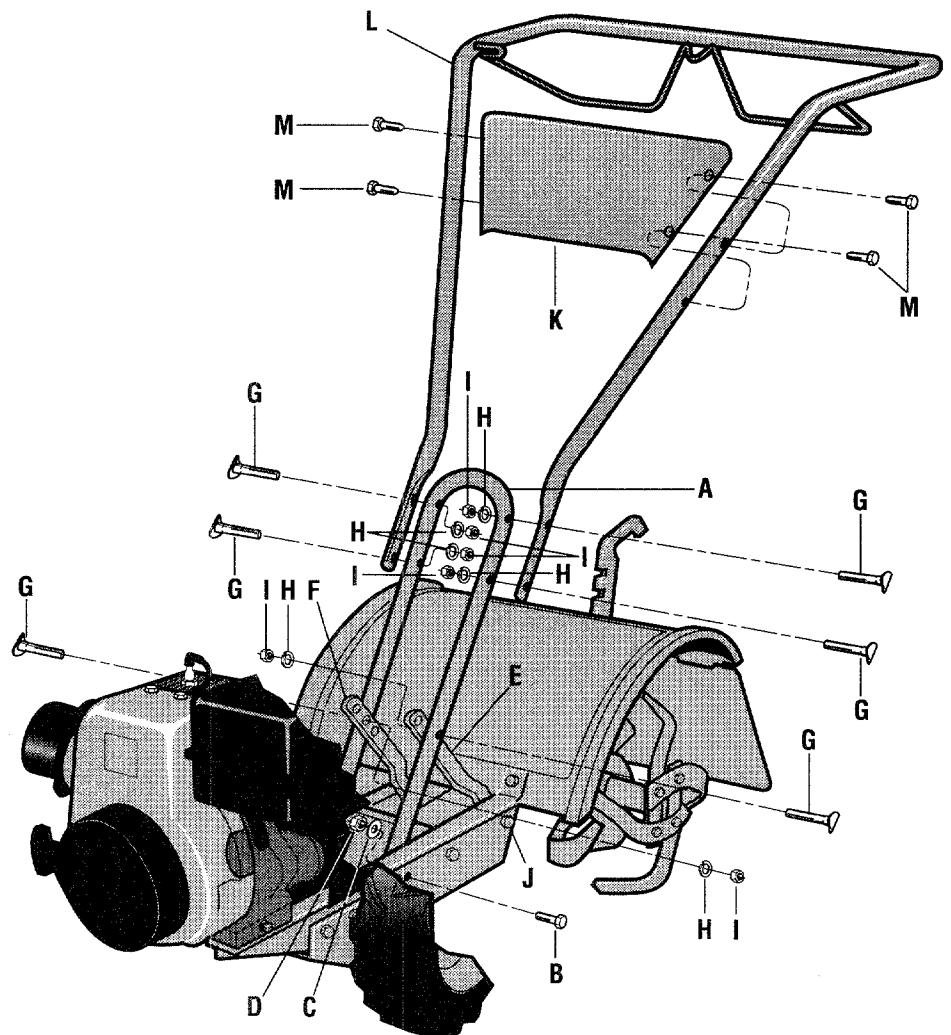

Fig. 2-2: Assemble handlebar.

4. Move Tiller Off Shipping Platform

To roll the tiller without the engine running, the wheels must be placed in their FREEWHEEL position, as described below.

1. Use a sturdy block to raise one wheel off the ground.

2. Remove the hair pin cotter (N, Fig. 2-3) and clevis pin (O). Slide the wheel inward on the axle (P) and reinstall the clevis pin and hair pin cotter through the axle only

(not through the wheel hub). Repeat with the other wheel.

3. Using the handlebar as a lever, roll the tiller to a flat area.

IMPORTANT: Before starting the tiller's engine, the wheels must be placed in their WHEEL DRIVE position (pins through wheel hubs and axle). This procedure is described in "Wheel Drive Pins" on Pages 12-13 in Section 3.

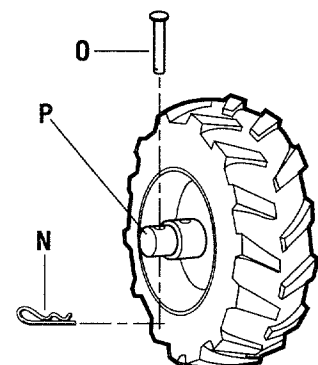

Fig. 2-3: Wheel in FREEWHEELING position.

5. Install Wheel Drive Cable

1. Place the cable bracket (R, Fig. 2-4) on the handlebar support (A) as shown.
2. Attach the cable bracket using a 1/4"-20 x 1-1/4" hex hd. screw (S, Fig. 2-4) and 1/4"-20 hex locknut (T). Tighten securely.
3. Unwrap the forward clutch cable (U, Fig. 2-4) from around the engine and slide the thin cable wire into the slot in the cable bracket. Push the cable connector (V, Fig. 2-4) up through the hole in the bracket until the groove in the connector snaps into place on the bracket.
4. Insert the #10-24 x 2" slotted hd. screw (W, Fig. 2-5) into the cable spring (X).
5. Thread the screw (W) into the cable adjuster (Y).
6. Hook the cable spring (X) into the "V"-shaped bend in the forward clutch bail (Z, Fig. 2-6).
7. Lift and hold the forward clutch bail against the handlebar. See Fig. 2-7.
8. Measure the distance between the coils of the cable spring (Fig. 2-7). The length should be approximately 1-7/8". If the length is incorrect, you will have to make an adjustment to the cable tension as described in "Checking and Adjusting Belt Tension" on Page 28.

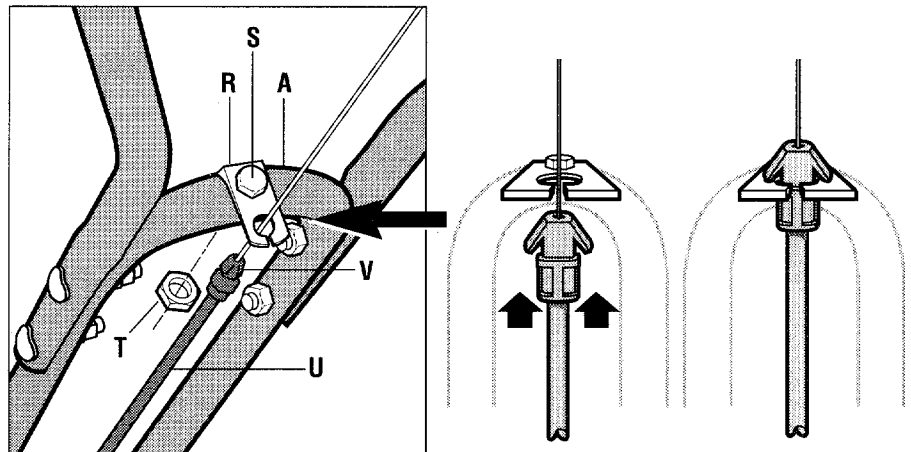

Fig. 2-4: Installing wheel drive cable bracket and cable.

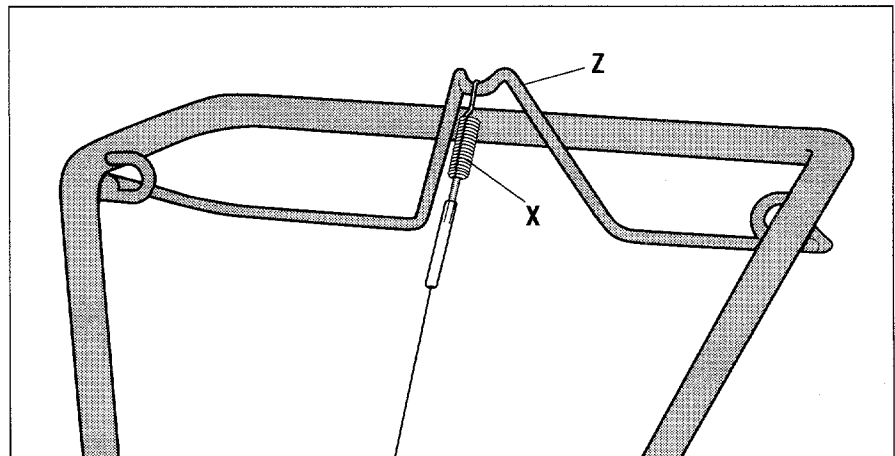

Fig. 2-6: Installing wheel drive cable.

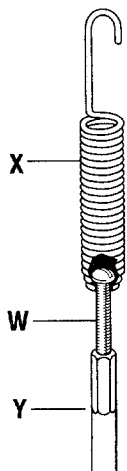

Fig. 2-5: Assemble spring and adjuster.

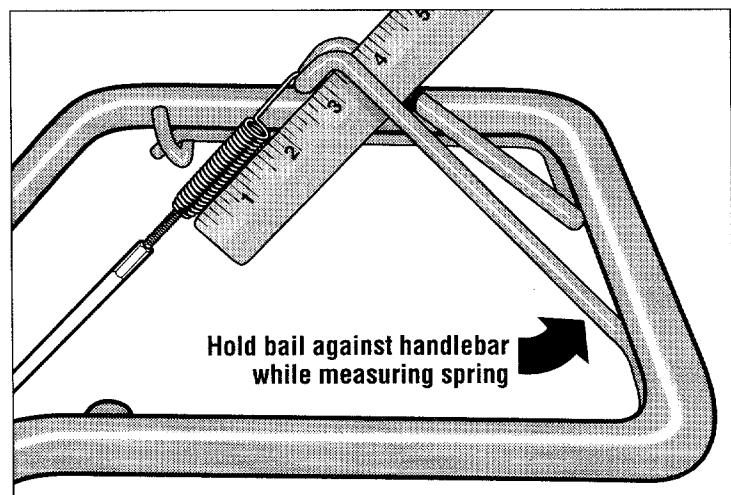

Fig. 2-7: Measure cable spring.

6. Check Level of Transmission Gear Oil

The transmission was filled with gear oil prior to being shipped. However, you should check the gear oil level to make certain it is correct.

1. With the tiller on level ground, pull the Depth Regulator Lever (AA, Fig. 2-8) back and then all the way up until the lowest notch in the lever is engaged.
2. Remove the plastic fill plug (BB, Fig. 2-9) from the transmission housing and look into the filler hole.
3. Inside the hole there is a grooved worm (CC, Fig. 2-10) on the drive shaft. If the gear oil level is correct, the gear oil should be approximately half way up the sides of the worm.
4. If the gear oil level is low, add gear oil by referring to "Checking and Topping off Transmission Gear Oil" on Page 24. **DO NOT OPERATE TILLER IF GEAR OIL LEVEL IS LOW. SEVERE DAMAGE TO TRANSMISSION WILL RESULT.**

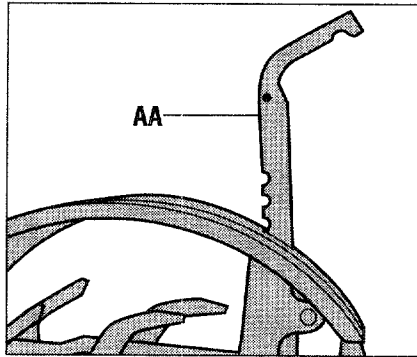

Fig. 2-8: Adjust Depth Regulator Lever.

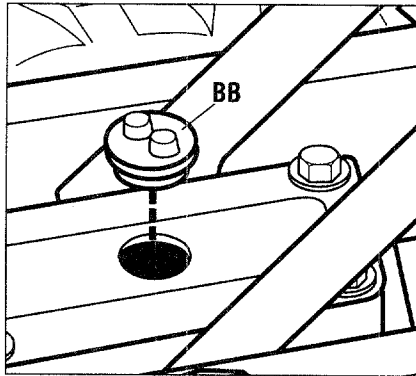

Fig. 2-9: Remove gear oil fill plug.

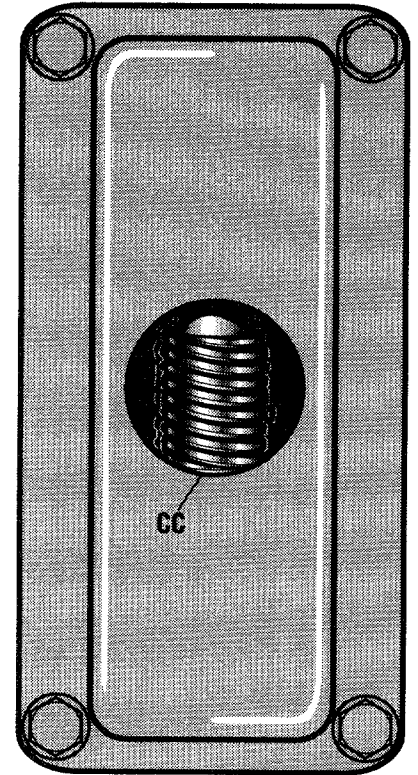

Fig. 2-10: Gear oil should be half way up sides of worm.

7. Add Motor Oil to Engine

The tiller is shipped without oil in the engine. **PERMANENT ENGINE DAMAGE WILL RESULT IF THE ENGINE IS RUN WITHOUT OIL.**

1. Refer to the Engine Owner's Manual (supplied with tiller) for engine oil specifications and capacities.
2. With the tiller on level ground, pull the Depth Regulator Lever (AA, Fig. 2-8) back and then all the way up until the lowest notch in the lever is engaged.
3. Unscrew the engine oil fill plug (DD, Fig. 2-11). Using a clean funnel, slowly add oil until the oil level reaches the overflow point in the oil fill tube. **ALWAYS**

MAINTAIN THE OIL LEVEL AT THE OVERFLOW POINT.

4. Securely replace the oil fill plug.

8. Check Hardware for Tightness

Check all nuts and screws for tightness.

IMPORTANT: Before operating your tiller, make sure you read the following Sections in this Manual, as well as the separate Engine Owner's Manual:

- Section 1: "Safety"
- Section 3: "Tiller and Engine Controls"
- Section 4: "Operation"

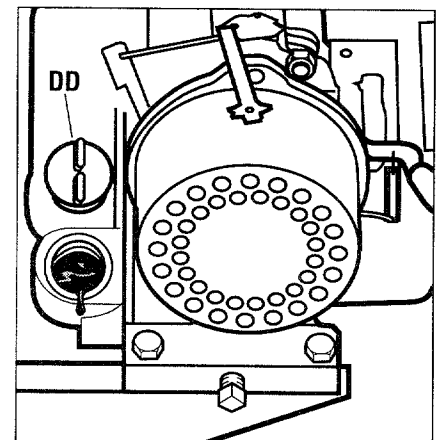

Fig. 2-11: Add motor oil to engine.

Section

3

Features and Controls

Read Me First!

Learn the locations of the features and controls on your machine before starting the engine. Taking the time now to understand the location, function and operation of these controls will greatly add to the productive use, safe operation, and enjoyment of your machine. For detailed step-by-step operating instructions, please refer to "Section 4: Operation."



WARNING

TO AVOID PERSONAL INJURY OR DAMAGE TO EQUIPMENT:

Before using your tiller for the first time, become thoroughly familiar with the operation of the controls by moving them to their various positions while the engine is not running. The proper operation of each control is discussed in detail in Section 4.

NOTE: All references to left, right, front and rear of the machine are determined by standing behind the handlebars and facing the direction of forward travel.

TILLER FEATURES AND CONTROLS IDENTIFICATION

The major tiller controls and features are identified and illustrated on the next few pages. The use and operation of each control and feature is covered in detail in Section 4 "Operating Instructions."

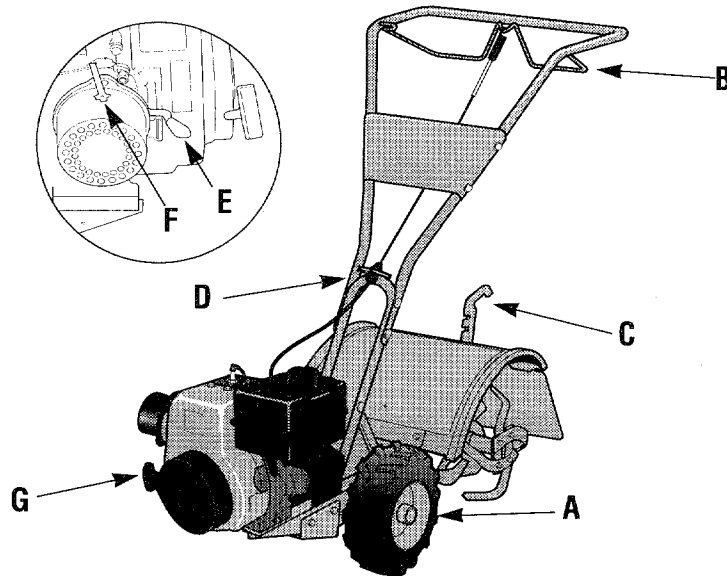

Figure 3-1: A- Wheel Drive Pins; B- Forward Clutch Bail; C- Depth Regulator Lever; D- Handlebar Height Adjustment; E- Engine Throttle Lever; F- Engine Choke Lever; G- Engine Recoil Starter.

A) Wheel Drive Pins

These two pins (one on each side of the wheel shaft), secure the wheels to the wheel shaft and can be positioned by you to put the wheels in either a WHEEL DRIVE or a FREEWHEEL mode.

Before starting the engine, put both wheels in the WHEEL DRIVE position by inserting the Wheel Drive Pins through the holes in **both** the wheel shaft and wheel hub on both sides of the tiller. This "locks" the wheels to the wheel shaft, causing the wheels to turn when you engage the Forward Clutch Bail.

Use the FREEWHEEL position only when the engine is off. This



WARNING

Never let either of the wheels be in FREEWHEEL position when the engine is running. Always put both wheels in the WHEEL DRIVE position before starting the engine.

Failure to comply could cause loss of tiller control, property damage, or personal injury.

position lets you easily push or pull the tiller. To use FREEWHEEL, place the Wheel Drive Pins only through the holes in the wheel shaft. This keeps the wheels on the shaft, but allows the wheels to rotate when you push or pull the tiller handlebar.

To Place Wheels in WHEEL DRIVE Position:

1. The engine must be shut off and cool. Disconnect spark plug wire and move it away from the spark plug.

2. Raise one wheel off the ground and place a sturdy support under the transmission.



WARNING

Do not place tiller on its side when changing wheel drive positions or gasoline could leak from the fuel tank.

Failure to follow this instruction could result in personal injury or property damage.

3. Remove the hair pin cotter from the wheel drive pin and pull out the wheel drive pin.

4. Slide the wheel outward and align the holes in the wheel hub and wheel shaft. Insert the wheel drive pin through these holes (see Figure 3-2). Insert the straight leg of the hair pin cotter into the hole in the wheel drive pin as far as it will go.

5. Repeat the above steps for the other wheel, then remove the support under the transmission.

To Place Wheels in FREEWHEEL Position:

1. Follow steps 1-through-3 of "To Place Wheels in WHEEL DRIVE Position."

2. Slide wheel inward on wheel shaft as far as possible.

3. Insert wheel drive pin only through the hole in the wheel shaft. Insert the straight leg of the hair pin cotter into the wheel drive pin as far as it will go. See Figure 3-3.

4. Repeat Steps 1-through-3 for the other wheel. Remove the support beneath the transmission.

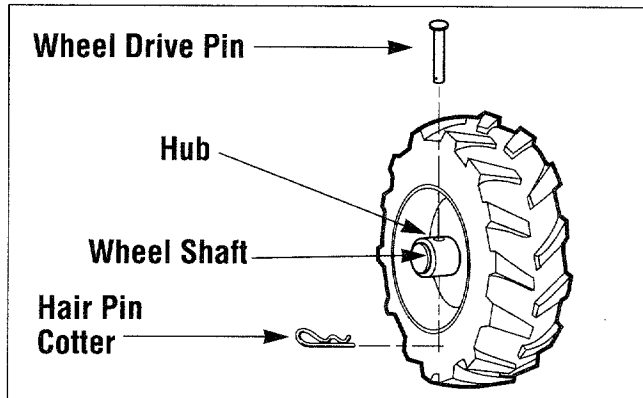

Figure 3-2: WHEEL DRIVE position.

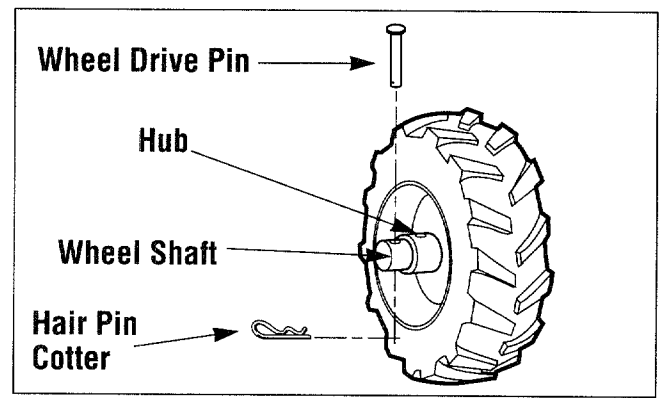

Figure 3-3: FREEWHEEL position.

B) Forward Clutch Bail

The Forward Clutch Bail (Photo 3-4) is used to engage or disengage (stop) the tiller wheels and tines.



WARNING

Before starting the engine, be sure that both wheels are in the WHEEL DRIVE position. See "Wheel Drive Pins" for instructions.

Failure to comply could result in loss of tiller control, personal injury or property damage.

Operate the Forward Clutch Bail as described below:

1. Put the wheels in the WHEEL DRIVE position.
2. Rest one hand, palm down, on top of the handlebar.
3. Use the other hand to lift up and hold the Forward Clutch Bail. See Photo 3-4. When the bail is in this position, the wheels/tines will rotate.
4. To stop forward motion of wheels/tines, release the Forward Clutch Bail.

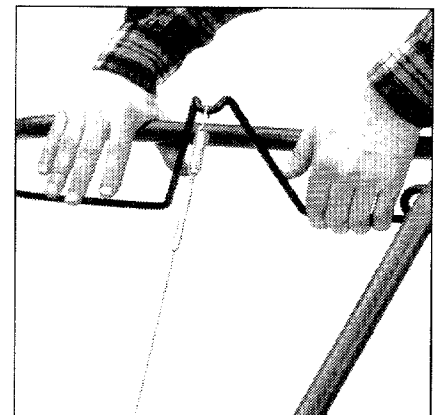

Photo 3-4: Operating the Forward Clutch Bail.

Features and Controls

C) Depth Regulator Lever



WARNING

Do not attempt to till too deeply too soon. Gradually work down to deeper tilling depths.

Failure to do so could result in loss of tiller control, personal injury or property damage.

This lever controls the depth that the tines penetrate the soil (see Figure 3-5). Adjust the lever to change tilling depth by pulling back on it and moving the lever up (for deeper tilling) or down (for shallower tilling).

To place the tines in the "travel" position, move the lever down to the highest notch. This raises the tines above the ground and allows the tiller to be moved without tilling. Do not attempt to till too

deeply too soon. Begin tilling with the lever adjusted down in one of the shallower settings. Gradually increase tilling depth by moving the lever upward.

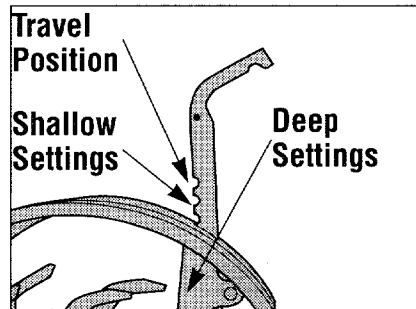

Figure 3-5: Depth Regulator Lever.

D) Handlebar Height Adjustment

You can adjust the tiller handlebar height to any one of three positions. (See Figure 3-6.) As a general guide, adjust the handlebars so they are at waist level when the tines are 3"-to-4" into the soil.



WARNING

Before adjusting handlebar height, shut off the engine, let it cool down, let all moving parts stop completely, then disconnect the spark plug wire and move it away from the spark plug.

Failure to do so can cause personal injury or property damage.

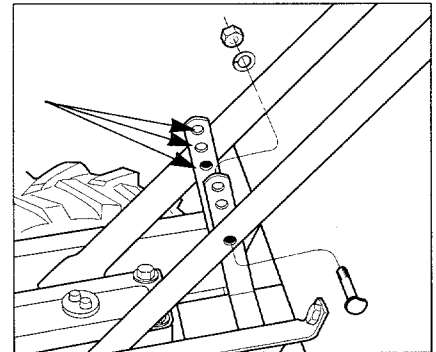

Figure 3-6: Handlebar adjustment offers three height settings.

ENGINE CONTROLS



WARNING

Release the Forward Clutch Bail before adjusting the Engine Throttle Lever.

Failure to comply could result in personal injury or property damage.

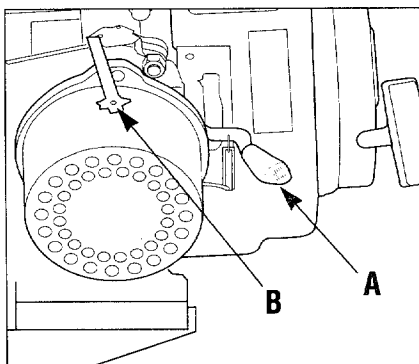

Figure 3-7: Engine Throttle Lever ("A") adjusts engine speed. Engine Choke Lever ("B") is used to assist starting when engine is cold.

E) Engine Throttle Lever

Adjust this lever (see A, Figure 3-7) to start and stop the engine and to regulate engine speed.

- To increase engine speed, move the lever upward to FAST (Rabbit symbol) position.
- To decrease engine speed, move the lever down toward SLOW (Turtle symbol) position.
- To stop the engine, move the lever all the way down to STOP position.
- To start the engine, move the lever to the FAST (Rabbit symbol) position.

F) Engine Choke Lever

The Choke Lever (B, Figure 3-7) allows a richer air/gasoline mixture (more gasoline) to enter the engine cylinder to make starting a cold engine easier. The lever has three settings: FULL

CHOKE, PARTIAL CHOKE and NO CHOKE.

Detailed instructions for using the Choke Lever are provided in the Operation Section (Section 4).

G) Engine Recoil Starter

The Engine Recoil Starter (refer to Figure 3-8) is used to start the engine. For full instructions on the use of this control, see Section 4.

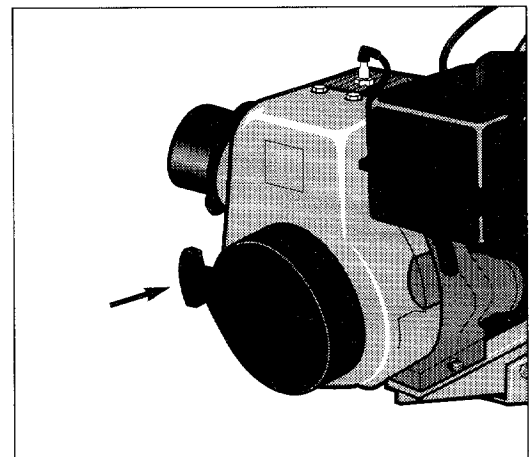

Figure 3-8: The Engine Recoil Starter rope is used to start the engine.

Section

4 Operation

Read Me First!

As with any other piece of outdoor powered equipment, getting the “feel” for how your machine operates and getting to know the best techniques for particular jobs are very important to overall good performance.

Read this Section very thoroughly before you start the engine. The instructions given here will help you familiarize yourself with your machine and have you operating it effectively in a short time.



WARNING

Before operating your machine, be sure you read and understand all safety, controls, and all operating instructions in this Owner/Operator Manual and on the decals on your machine.

Failure to follow these instructions can result in serious injury or property damage.

NOTE: All references to left, right, front and rear of the machine are determined by standing behind the handlebars and facing the direction of forward travel.

This Section explains:

- Break-In Operation
- Pre-Start Checklist
- Starting the Engine
- Stopping the Engine
- Guiding The Tiller
- Tilling Depths
- Moving the Tiller Forward
- Moving the Tiller Rearward
- Turning the Tiller Around
- Tilling in the Garden
- Seedbed Preparation
- Cultivating
- Power Composting
- “High Traction” Frame Weights
- Preventing Tangling on Tines
- Tilling on Slopes
- Terrace Gardening
- Loading/Unloading the Tiller

Break-In Operation

Be sure to perform the following maintenance during the first few hours of new tiller operation. Refer to the Maintenance Section for regularly scheduled maintenance procedures.

1. Change engine oil after the first two hours of new tiller operation.
2. Check the transmission gear oil level after the first two hours of operation.
3. Check the tension on the forward drive belt after the first 2-to-3 hours of operation.
4. After the first two hours of operation, check all fasteners (nuts, bolts, screws) for tightness.



Photo 4-1

Pre-Start Checklist

Move the tiller to a level area, then make the following checks and perform the following services *before* starting the engine.

1. **Disconnect Spark Plug Wire.**
2. **Check Engine Oil Level.**
3. **Check the Air Cleaner.** It must be securely assembled and clean.
4. **Check Safety Guards.** All guards and covers must be fastened securely in place.
5. **Check Engine Cooling System.** The cooling fins and air intake screen must be clear of debris.
6. **Adjust Handlebar Height.**
7. **Check that the Wheels are in the WHEEL DRIVE position.**
8. **Put Gasoline in the Fuel Tank.** Use fresh, clean, unleaded fuel. Fuel goes stale if stored for more than six months. *Do Not Mix Oil With Gasoline!*
 - a. Clean the fuel cap area before removing the fuel cap.
 - b. Use a clean funnel to add gas.
 - c. Fill tank to within 1/2" of the top to prevent spills and allow for fuel expansion.
9. **Put Depth Regulator Lever in the "travel" position.**
10. **Reconnect Spark Plug Wire.**



DANGER

Do not run the engine indoors. Engine exhaust contains carbon monoxide, a deadly gas that is colorless, odorless and tasteless.

Failure to follow this instruction could result in serious personal injury or property damage.

Starting the Engine

1. Do not engage (hold) the Forward Clutch Bail against the handlebar.
2. Both wheels must be in the WHEEL DRIVE position (see Figure 3-2).



WARNING

Always place both wheels in the WHEEL DRIVE position before starting the engine.

Never have the wheels in the FREEWHEEL position when the engine is running. When the wheels are in FREEWHEEL, they do not hold back the tiller, and the tines could propel the tiller forward rapidly.

Failure to comply could result in serious personal injury or property damage.

3. Move the Choke Lever to the FULL CHOKE position. (An engine which is warm from operation may start without moving the Choke Lever at all.)
4. Move the Engine Throttle Lever fully up to FAST (Rabbit) position which is used for starting.

5. Place your left hand on the gasoline tank to stabilize the tiller when starting.
6. Use your right hand to slowly pull the recoil starter rope until you feel resistance. Then rapidly pull the starter rope outward. (First check for any obstacles behind you.) Repeat until the engine starts.

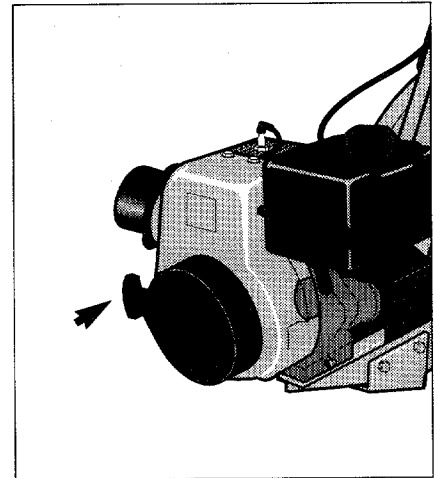

Figure 4-2: Pull Recoil Start Rope out rapidly to start engine.

7. Once the engine is running, gradually move the Choke Lever to the NO CHOKE position.
8. Move the Engine Throttle Lever to the position that provides the desired engine speed.



DANGER

Gasoline is highly flammable and its vapors are explosive. Follow these safety practices to prevent injury from fire or explosion:

- Never fill tank if engine is running or hot from use. Let engine and muffler cool down before refueling.
- Do not permit open flames, sparks, matches or smoking in fueling area.
- Fill fuel tank outdoors in a well-ventilated area. Wipe up any fuel spills and move tiller away from fumes before starting the engine.
- Use only an approved fuel container and lock it safely away from children.
- Store fuel and the tiller in a well-ventilated area. Do not store fuel or tiller where fuel vapors may reach an open flame or spark, or an ignition source (a hot water heater, furnace, clothes dryer, electric motor, or the like).
- Let engine cool before storing.

Stopping the Engine

1. Release the Forward Clutch Bail to stop the wheels and tines from turning.
2. Move Engine Throttle Lever to STOP position to stop the engine.

NOTE: If moving the Engine Throttle Lever to STOP does not shut off the engine, you can stop the engine by moving the Choke Lever to the FULL CHOKE position. However, do not continue to stop the engine using the Choke Lever because doing so may damage the engine. Repair the Engine Throttle Lever as soon as possible.

Guiding the Tiller

When tilling, relax and let the tiller move along at its own speed. Do not push the tiller to make it move faster. Do not push down on the handlebars to make the tines dig more deeply.

Walk beside the tiller on the untilled side. Use one hand, yet keep a firm hand grip on the handlebar (while keeping your arm loose) to guide the tiller. Walking alongside keeps you from disturbing the newly tilled soil and replanting any weed seeds which the tines might have brought up to the surface. It is also easier to control the tiller in hard or rocky soil if you walk beside it guiding it with one hand. (Instead of walking behind it, controlling the tiller with two hands.)

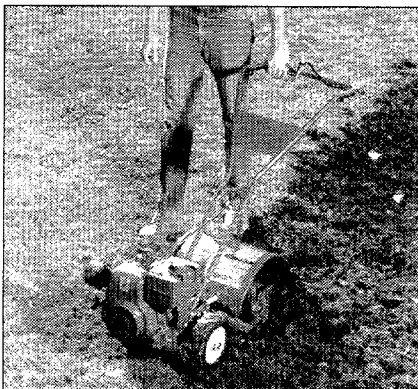

Photo 4-3: Tilling With Just One Hand is recommended.

Tilling Depths



WARNING

Always begin tilling at a shallow Depth Regulator Lever setting and gradually work down to deeper settings.

Failure to comply could result in loss of tiller control, property damage or personal injury.

Do not try to till too deeply at first. Gradually raise the Depth Regulator Lever (one notch at a time) so the tiller digs slightly deeper with each pass. This allows thorough tilling and minimizes the chance of the tiller jumping or “bucking.”

When cultivating between rows, use a shallow Depth Regulator Lever setting. This will get rid of in-row weeds, but prevent the tines from digging deeply enough to damage plant roots.

Moving the Tiller Forward

IMPORTANT: Before you begin tilling, move the tiller to a safe, level area and practice maneuvering the tiller without actually tilling. Keep the Depth Regulator Lever in the “travel” position. After you become familiar with the handling of your tiller, you can move it into the garden and begin tilling.

1. Put the wheels in the WHEEL DRIVE position (wheel pins must be through the wheel hubs and the axle holes).
2. Start the engine.
3. Move the Depth Regulator Lever to the desired position.
4. For forward motion of the wheels and tines, lift and hold the Forward Clutch Bail against the handlebars. The wheels and tines will rotate as long as the bail is held in this position.

5. As the tiller moves forward, let the wheels pull the tiller along. Do not push the tiller to make it go faster. Allow the tiller to move along at its own speed.



WARNING

Do not push down on the handlebars to try to make the tiller till more deeply. This prevents the wheels from holding the tiller back and can allow the tines to rapidly propel the tiller forward, which could result in loss of control, property damage, or personal injury.

6. To stop the wheels and tines, release the Forward Clutch Bail. The engine will continue to run until stopped by moving the Engine Throttle Lever to the STOP position.

Moving the Tiller Rearward

The tiller weighs only 117 pounds, so it is quite easily maneuvered rearward for short distances by using the follow procedure:

1. Release the Forward Clutch Bail.
2. Tilt the tiller slightly forward until the tines are out of the soil.
3. Place both hands on the corners of the handlebars. Tilt the tiller slightly to raise the right wheel off the ground.
4. Slowly swing the handlebars to the left so the right wheel takes a “step” toward the rear.
5. Set the right wheel back down.
6. Now tilt the tiller so the left wheel is slightly off the ground and slowly move the handlebars to the right so the left wheel takes a step backward.
7. Repeat to “walk” your tiller rearward.

Operation

Turning the Tiller Around

Practice turning your tiller in an open, level area until you feel comfortable with the procedure.

1. As you near the end of a row, lift the handlebars so the tines clear the ground. Refer to Photo 4-4.



Photo 4-4: Exiting a row in the garden.

2. As you come out of a row, swing the handlebars to the side, pivoting the tiller 180°, so you can line up with the next row. See Photo 4-5.

3. As the tiller enters the next row, lower the handlebars slowly until the tines start to till.



Photo 4-5: Lining up the tiller to enter the next row.

Tilling in the Garden

The following pages provide many ideas about using the tiller in the garden. You can often design your garden layout to obtain the most beneficial use from your tiller.

Seedbed Preparation

Prior to planting, be sure the soil is as loose and finely textured as possible due to proper tilling. About two or three weeks before planting, till the garden two or three times. Then, till once more before planting. This final tilling helps plants get a head start on future weed growth.

When preparing the soil, go over the same path twice in the first row. Then overlap one-half the tilling width on each succeeding pass. See Figure 4-6. After going up and down the rows in one direction, make a second pass at a right angle across your earlier rows. See Figure 4-7. Again, overlap each pass to really pulverize the soil. (In very hard ground, three or four passes may be needed.)

If your garden isn't long enough to till lengthwise and then crosswise, first overlap each pass by

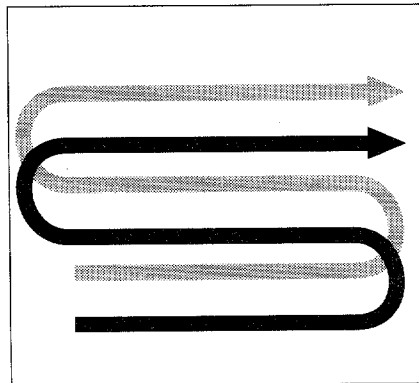

Figure 4-6: Initial tilling pattern.

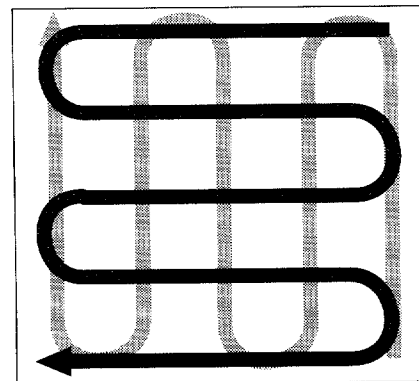

Figure 4-7: Second tilling pattern.

one-half a tilling width, followed by successive passes of one-quarter a tilling width. See Figure 4-8. Don't till when the soil is too wet. This produces large clumps which later dry out and become hard. If the soil compresses easily into a ball, it is still too wet to be tilled.

Avoid Making Footprints

When tilling, always try to walk alongside the tiller on the side that is yet to be tilled. This prevents replanting weed seeds and leaves a nice appearance.

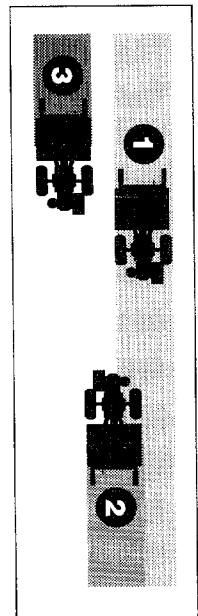

Figure 4-8: Tilling narrow strips.

Cultivating

When planning your garden, keep in mind that the tiller has a tilling width of approximately 14". Allow at least this width between rows in your garden— plus additional width for plant growth. Take into account that bushy plants like beans and tomatoes need more width. Refer to Photo 4-9.

When cultivating, use a shallow Depth Regulator Lever setting. Do not cultivate deeper than 1"-or-2". Shallow cultivating keeps weed growth to a minimum and doesn't damage plant roots.

For best results, begin cultivating as soon as seedlings appear, and then cultivate as often as once a week. The day after a light rain is an excellent time to cultivate, as long as the plants are dry. Avoid working in the garden when plants are wet. Diseases, blight, and rust can be easily spread among wet plants with your hands, clothing or even the tiller.



Photo 4-9: Cultivating within rows.

Power Composting

To keep your garden productive, regularly till organic matter back into the soil (Photo 4-10). This

helps replace any nutrients harvested (as vegetables), and also improves soil structure.

A simple method of power composting is to chop, blend and till under leafy crop residues, leaves, grass clippings and "green manure" crops. This organic matter will decompose and add important nutrients back into garden soil.

When composting, put the Depth Regulator Lever at the deepest setting that does not allow the tiller to jump or cause the engine to labor.



CAUTION

When power composting, do not keep the Depth Regulator Lever at a deep setting if the tiller jumps or bucks.

If jumping or bucking occurs, move the Depth Regulator Lever down to one of the shallower settings and then slowly increase the tilling depth on later passes.

Failure to comply could result in loss of tiller control, property damage or personal injury.



Photo 4-10: Power Composting "feeds" your garden.

Till crop residues back into the soil as soon as the vegetables are harvested. Green, tender crops are more easily tilled.

Since the tiller is a comparatively lightweight machine, we don't recommend it for power composting large standing crops such as cornstalks. However, you can uproot the leftover green cornstalks, run them through a shredder, or chop them into smaller pieces and then scatter them on your garden. This allows you to power compost them back into the soil.

After tilling under crop residues, you can plant a cover crop such as buckwheat, annual ryegrass, peas, or beans to protect your garden soil. This builds soil, adds nutrients to the garden and helps control soil erosion.

High-Traction Frame Weights

The "High-Traction" Frame Weight Kit is a handy accessory for your tiller. This kit consists of two 13-1/2 lb. cast iron weights which attach to the tiller frame right above each wheel axle.

To till very heavy soil or improve tiller traction, the weights are what you need. The weights allow you to till under tougher conditions and till deeper at a somewhat faster rate.

Operation

Preventing Tines From Becoming Tangled

When power composting, you may find that the tines become tangled with material (tall vegetation, long grass, tough vines, etc.).



WARNING

Before removing any debris from the tines, stop the engine, allow it to cool, disconnect the spark plug wire and move it away from the spark plug.

Failure to do so could result in personal injury or property damage.

To help prevent tangling:

1. While tilling, swing the handlebars from side-to-side about 6"-to-12". This "fishtailing" action will often dislodge any debris.
2. Always use the deepest Depth Regulator Lever setting possible (without making the tiller jump or buck upward).
3. Till under cover crops and crop residues while they are still green.
4. Shred or chop up any tall, tough, or stringy organic matter before tilling it into the soil.



Photo 4-11: Cutting tangled tines.

5. You may have to mow or cut vegetation before power composting.
6. If the tines are heavily tangled, stop the engine and disconnect the spark plug wire. Then, cut away any debris.

Tilling on Slopes

Plant your garden preferably on flat ground, but certainly on no more than a moderate slope. Do not operate the tiller on a slope that is too steep for safe operation.

Plant garden rows vertically on a slope (up and down the slope). This lets you use the entire area for a seedbed and leaves enough room between the rows for cultivation. You lose these valuable benefits when you terrace garden (discussed later).

If you put enough organic material into your garden's soil to improve its water-holding capabilities, you should not have a problem with soil erosion.

When you begin to till vertically on a slope, start at the bottom and go up. The tines dig in more deeply when you go uphill than when you go downhill. As you turn around at the top to go back down the hill, overlap the uphill pass by about half the tilling width.



WARNING

Do not operate the tiller on a slope that is too steep for safe operation. Till slowly and be sure that you have good footing.

Failure to do so could result in personal injury or property damage.

NOTE: When you till on a slope, the oil level in the tiller engine slants toward the downhill side of the engine. Some internal parts may not get enough oil. To prevent this, make sure that the engine

oil level is full to the point of overflow from the oil check tube *before starting to till*. Also check the oil level every thirty minutes while you're tilling on a slope.

Terrace Gardening

If your garden is too steep or too short for vertical tilling, you may have to till across the slope. To achieve best results, use your tiller to create terraces for your garden.

Make the terrace 2-to-3 feet wide. You can plant one or two rows of plants in each terrace and later till the plants under. However, you may not have enough room to use the tiller for cultivating. If you make the terrace too wide, you would have to dig as much as a foot into the uphill side of the terrace and would end up trying to grow plants in poor subsoil.

Start to terrace at the top of the slope and work down. Always keep the uphill wheel in soft, newly tilled soil. Start each succeeding terrace by walking below the terrace you are preparing. In three or four passes you can create a terrace wide enough for planting.

Leave at least a 12" wide untilled space between terraces. Keeping the soil unbroken here will help prevent the terraces from breaking apart. Refer to the next page – see Figure 4-12 – for important information on making terrace gardens.

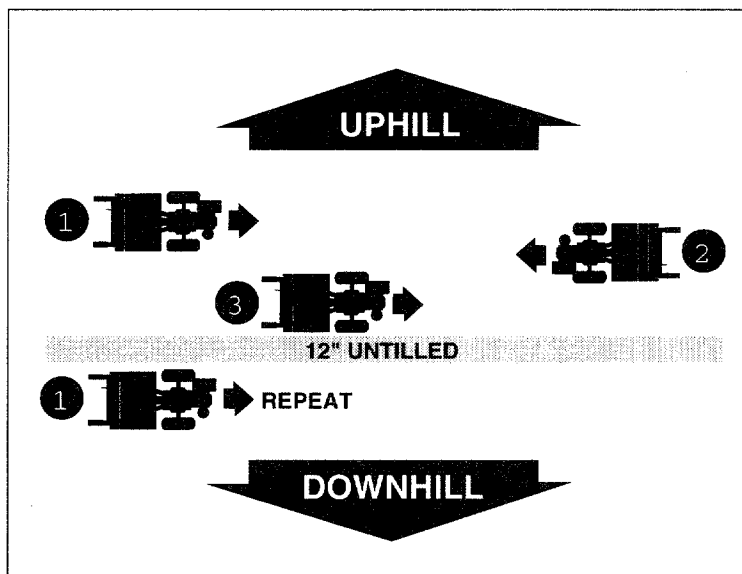

Figure 4-12: Creating a terrace in just three passes with the tiller.

Loading and Unloading the Tiller



CAUTION

Loading and unloading a tiller into or from a vehicle is potentially hazardous. We do not recommend that you do so unless absolutely necessary because this could result in personal injury or property damage.

If loading or unloading must be undertaken, use the following guidelines to assist you.

- Shut the tiller engine off before loading or unloading. Allow the tiller engine to cool, disconnect the spark plug wire and prevent the wire from touching the spark plug.
- The tiller is too heavy (over 115 lbs.) and bulky to be safely lifted by one person. If you do lift the tiller, two or more people should share the load.
- We recommend that you use sturdy ramps and that you manually roll the tiller into or out of the vehicle (tiller engine must be off). This requires the assistance of another person.
- Ramps should be strong enough to support the tiller and those moving it. The ramps should provide good traction; they should have side rails to guide the tiller up and down the ramps; and they should have a locking device to secure them to the vehicle bed.
- The operator and handlers should wear sturdy footwear that grips well to prevent slips.
- Position the vehicle so the ramp angle is as flat as possible. Turn the vehicle engine off and apply the vehicle parking brake.
- When going UP ramps, stand in the normal operating position and push the tiller ahead of you. Position a person at each wheel to turn the wheels.
- When going DOWN ramps, walk backward down the ramps with the tiller following you. Keep alert for and avoid any obstacles which could cause you to fall. Position a person at each wheel to control the speed of the tiller. Never go down ramps tiller-first, because the tiller could tip forward.
- Have wood blocks handy to place on the downhill sides of the wheels if you need to stop the tiller from rolling down the ramps while loading or unloading. Use the blocks to temporarily keep the tiller in place on the ramps while you get a firmer grip on the handlebars, reposition the tiller, etc. Also use the block to keep the wheels in place after tying down the tiller.
- After positioning the tiller in the vehicle, be sure both wheels are engaged in the WHEEL DRIVE position to prevent the tiller from moving. Then securely tie down the tiller.

Section

5

Maintenance/Repairs

Read Me First!

Carefully read this Section on engine and tiller maintenance and service. Performing the required maintenance according to schedule will ensure the proper performance and long life of your machine.



CAUTION

Before inspecting, cleaning or servicing the machine, shut off engine, make sure that all moving parts have come to a complete stop, then disconnect spark plug wire and move wire away from spark plug.

Failure to follow these instructions can result in personal injury or property damage.

NOTE: All references to left, right, front and rear of the machine are determined by standing behind the handlebars and facing the direction of forward travel.

Subjects covered in this Section include:

- Regular Maintenance
- Tiller Lubrication
- Checking and Adding Engine Oil
- Changing Engine Oil
- Checking Transmission Gear Oil
- Changing Transmission Gear Oil
- Checking for Oil Leaks
- Air Cleaner Maintenance
- Engine Cooling System Maintenance
- Engine Ignition System Maintenance
- Tightening Tiller Hardware
- Removing and Installing Tine Assemblies
- Removing and Installing Single Tines
- Checking and Adjusting Belt Tension
- Belt Removal and Replacement
- Forward Clutch Bail Adjustment
- Tiller Storage

REQUIRED MAINTENANCE SCHEDULE

REQUIRED MAINTENANCE	Before Each Use	Every 10 Hours	Every 30 Hours	Every 50 Hours	As Noted
Check Engine Oil Level	•				1
Clean Engine Cooling Fins	•				
Check Bolts and Nuts		•			3
Change Engine Oil		•			2
Check Tension on Drive Belt		•			3
Lubricate Tiller		•			
Check Transmission Gear Oil Level			•		4
Check Tines for Wear			•		
Inspect Spark Plug				•	
Replace Paper Air Filter Cartridge				•	5

NOTE 1 – Check frequently during first 2 hours of new operation; thereafter every 5 hours.

NOTE 2 – Change after 2 initial operating hours; thereafter every 10 hours.

NOTE 3 – Check after 2 initial operating hours; thereafter every 10 hours.

NOTE 4 – Check after 2 initial operating hours; thereafter every 30 hours.

NOTE 5 – Replace more often if used in extremely dusty or dirty conditions

Regular Maintenance

Because the tiller is operated in the garden, frequently under hot and dirty conditions, regular maintenance is very important to ensure that you are getting proper performance from your tiller. There are several items of maintenance that will help keep your tiller in good operating condition:

- Change engine oil regularly.
- Lubricate the controls regularly.
- Keep the correct tension on the forward drive belt.
- Replace the engine air cleaner element when dirty.
- Keep engine cooling fins clean.

Tiller Lubrication

Refer to Photo 5-1 and Figure 5-2 for lubrication points on your tiller.

Use ordinary, clean motor oil (#30 weight) when oil is called for. When possible, use a good quality grease with a metal lubricant additive. However, regular automotive grease is acceptable.

1. Wheel Shaft

Remove the wheels and use a clean rag to wipe off old grease from the wheel shaft ("1", Photo 5-1). Inspect the shaft and use fine sandpaper to remove any rust or burrs. Apply new grease to the wheel shaft. This makes future wheel removal easy.

2. Depth Regulator Lever

Clean and grease the back, front and sides (refer to "2", Photo 5-1).

3. Handlebar Support Bolts

Oil the threads on both handlebar support bolts ("3", Photo 5-1).

4. Tine Shaft

Remove the tine holder assemblies and clean any rust or burrs from the shaft ("4", Photo 5-1) with a fine sandpaper. Liberally apply grease to the tine shaft.

5. Shifting Mechanism

Carefully oil all of the pivot points on the shifting mechanism ("5", Figure 5-2).

NOTE: When you oil the pivot points on the shifting mechanism, be sure that you do not get any oil on either the belt or the pulleys. Otherwise, the belt could slip and be unable to transfer engine power to the transmission.

Checking and Adding Engine Oil

NOTE: Check the engine oil level frequently during the first two hours of engine break-in operation.

Always check the engine oil level before starting the engine

(refer to Figure 5-3 below). When operating the tiller, stop the engine and check oil level every 5 operating hours. Running the engine when low on oil can cause expensive damage. Keep oil level at the overflow point in the oil fill hole.



WARNING

Stop the engine, allow it to cool, disconnect the spark plug wire from the spark plug and move the wire away from the plug before checking engine oil level.

Failure to do so could result in personal injury or property damage.

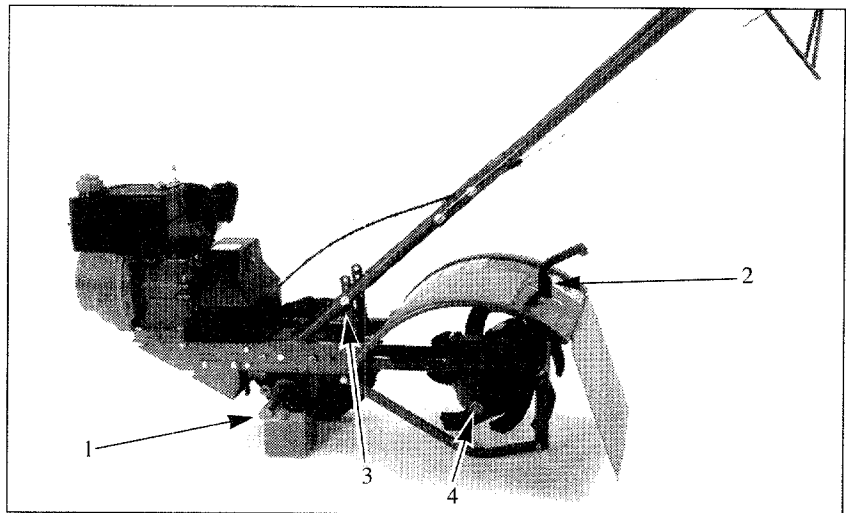

Photo 5-1: Tiller lubrication points.

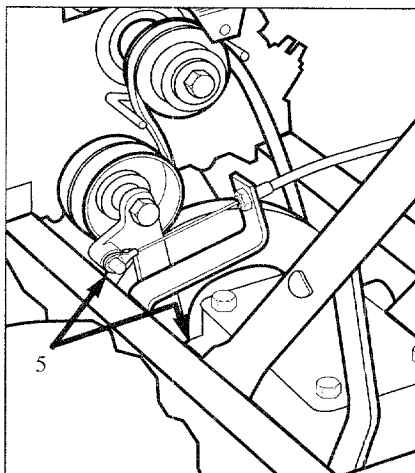

Figure 5-2: Lubrication points on shifting mechanism.

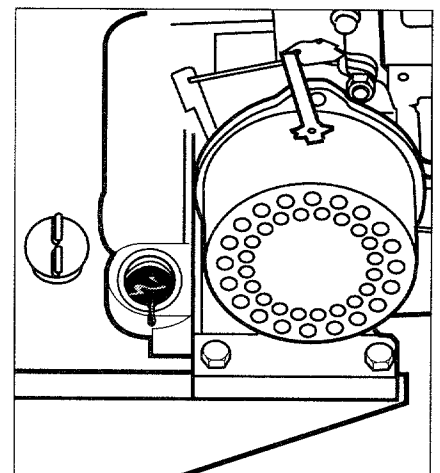

Figure 5-3: Oil Fill Plug location.

Checking Engine Oil Level:

1. Move the tiller to a level area.
2. Pull the Depth Regulator Lever all the way up until it is in the bottom notch.
3. Unscrew the oil fill plug from the right side of the engine (see Figure 5-3).
4. If the oil level is correct, the level will crest at the top of, or begin to flow from, the oil fill tube. Reinstall the oil fill plug.
5. If the level of the oil was below the very top of the fill hole, oil must be added as follows.

Adding Engine Oil:

1. Insert a clean funnel into the oil fill hole.
2. Select the correct type and weight of engine oil according to the separate Engine Owner's Manual.
3. Slowly pour oil into the funnel. Check the oil level frequently while pouring. (Remove the funnel when checking.) When the oil just begins to overflow, the level is correct.
4. Replace the oil fill plug securely.

Changing Engine Oil

Change the engine oil after the first two hours of initial tiller operation. Thereafter, change the engine oil every ten operating hours.

NOTE: The engine manufacturer recommends that the engine oil be changed after 25 hours of operation. Because the tiller is constantly operated in a dusty, dirty environment, we recommend that you change the oil every 10 operating hours (or even sooner if the environment is extremely dirty or dusty).

Changing the engine oil removes impurities and contaminants which would otherwise increase wear on

internal engine parts. New oil assures that the various internal moving parts of the engine receive proper lubrication.



WARNING

Stop the engine, allow it to cool, disconnect the spark plug wire and prevent it from touching the spark plug before changing the engine oil. Do not touch any engine parts which may be hot.

Failure to do so could result in personal injury or property damage.

1. Start the engine and allow it to run until it is warm. Then TURN THE ENGINE OFF.
2. There are two engine oil drain plugs on either side of the engine base. Use whichever one is most conveniently located for you.
3. Place a 2"x 4" wood board under the wheel opposite the drain plug you'll be removing.
4. Place a drain pan with a minimum capacity of 1-quart beneath the drain plug.

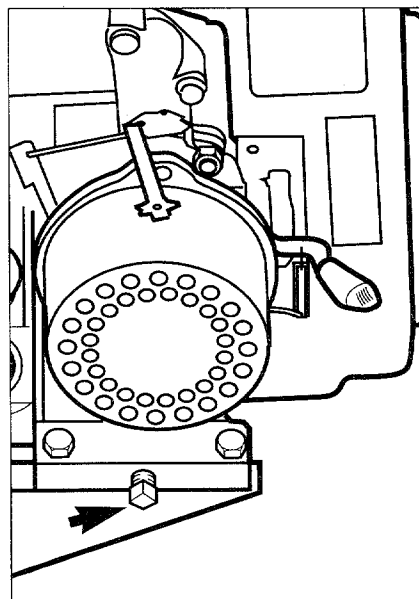

Figure 5-4: Draining engine oil.

5. Use a 3/8" open end wrench to remove the drain plug (see arrow in Figure 5-5). Put it aside. Let all of the old engine oil drain completely into the drain pan.
6. Reinstall the drain plug securely.
7. Remove the wood board from beneath the wheel.
8. Refill the engine with the correct type and weight of engine oil. See your separate Engine Owner's Manual for specifications.
9. Check the oil level to be sure it is correct before starting the engine.



WARNING

Stop the engine, allow it to cool, disconnect the spark plug wire and prevent it from touching the spark plug before checking, adding or changing the transmission gear oil. Do not touch any engine parts which may be hot.

Failure to do so could result in personal injury or property damage.

Checking and Topping-Off Transmission Gear Oil

Checking Transmission Gear Oil:

1. Move the tiller to a level area.
2. Pull the Depth Regulator Lever all the way up.
3. Unscrew the filler/check plug from the top of the transmission (it is located just behind the belt cover).
4. Use a flashlight to look down into the filler/check plug hole. Note the worm gear on the drive shaft (refer to Figure 5-5 inset). Look on either side of the worm gear to see the surface of the gear oil. If the gear oil level is correct, it should be halfway up the sides of the worm gear. If topping off is required, follow instructions given next.



Photo 5-5: Checking the transmission gear oil level. The Inset Figure shows the worm gear.

Topping off Transmission Gear Oil

1. Complete steps 1-through-3 described in “Checking Transmission Gear Oil.”

2. Insert a funnel into the filler/check plug hole.

NOTE: When adding only a few ounces of gear oil, use API rated GL-4 or GL-5 transmission gear oil with a viscosity of SAE 140, SAE 85W-140, or SAE 80W-90. **When adding a complete refill of new gear oil after having drained the transmission, refill only with SAE 140 or SAE 85W-140 with an API of GL-4.**

3. Slowly pour clean gear oil into the transmission. Frequently check the level so as not to overfill the transmission. See Figure 5-6.

4. When the gear oil level is correct, reinstall the filler/check plug securely.

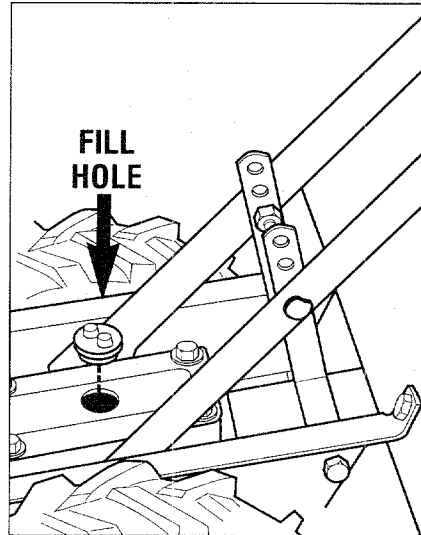

Figure 5-6: Gear oil fill hole.

Changing Transmission Gear Oil

The transmission gear oil does not have to be changed unless you know that it has been contaminated by foreign materials such as sand, dirt, or metal particles. Of course, any internal repairs on the transmission would also require that the gear oil be drained and changed.

1. Drain gasoline from the fuel tank or run the engine until the fuel tank is empty.
2. Drain the oil from the engine.
3. Remove the four bolts and washers securing the transmission cover to the front part of the transmission. Lift the cover and gasket off the transmission. See Figure 5-7.
4. Remove the left wheel.
5. Lower the left axle down into a drain pan and slowly tilt the tiller to the left so the gear oil drains from the top of the transmission into the drain pan. See Photo 5-8.
6. Once gear oil has drained, tilt tiller upright and reinstall wheel.
7. Reinstall the transmission cover using a new cover gasket.
8. Add new gear oil—see specifications in NOTE at left.
9. Add engine oil to the engine.



DANGER

Gasoline is highly flammable and its vapors are explosive. Follow these safety practices to prevent personal injury or property damage from fire or explosion.

- Allow the engine and muffler to cool for at least two minutes before draining the tiller’s gasoline tank.
- Do not allow open flames, sparks, matches or smoking in the area.
- Wipe away spills and push tiller away from spilled fuel.
- Use only an approved fuel container and store it safely out of the reach of children.
- Do not store gasoline in an area where its vapors could reach an open flame or spark, or where ignition sources are present (such as hot water and space heaters, furnaces, clothes dryers, stoves, electric motors, etc.)

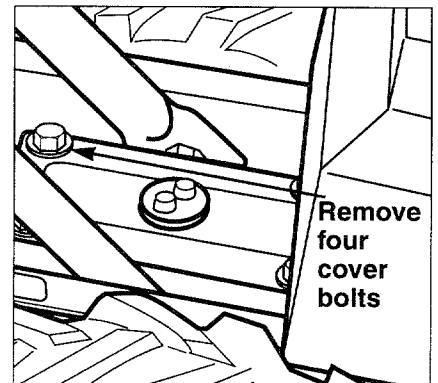

Figure 5-7: Removing front cover.

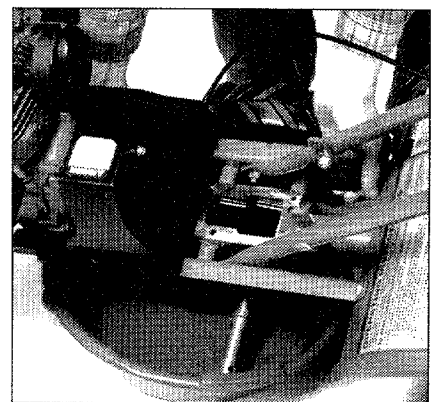

Photo 5-8: Draining the gear oil.

Maintenance/Repairs

Checking for Oil Leaks

Regularly check your tiller for oil leaks from the engine and the transmission. Slight seepage is no cause for major concern. However, if your tiller is losing a lot of oil, do not use it until it's repaired.

Inspect the area where you park your tiller for stains on the floor which would indicate a leak. If you find a leak, first tighten any bolts or screws which may have loosened up.

If you are unsure how much oil has been lost from the tiller, check the oil levels before operation. Also, when operating your tiller, frequently check the oil levels to be sure that engine oil and transmission gear oil levels don't become too low for safe operation.

If you have further problems with oil leaks, contact our Technical Service Department for assistance.

Engine Cooling System Maintenance

Frequently inspect the engine cooling fins, shrouds, and throttle linkage for a build-up of dirt, dried weeds, grease, etc.

Always keep these areas free from debris to keep air currents flowing freely. See Photo 5-10.

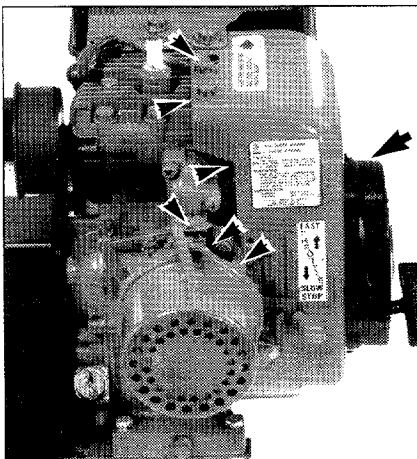

Photo 5-10: Keep these areas free of debris.

Air Cleaner Maintenance

Your tiller's engine is equipped with a replaceable dry paper filter. Replace this filter every 50 operating hours or at least once a year, more frequently under dusty or dirty operating conditions.

Do not attempt to clean this filter. Simply replace it when dirty.

To Remove Paper Air Filter:

1. Loosen the two screws that secure the air cleaner cover to the base of the air cleaner.
2. Slightly turn the cover counter-clockwise. Remove the cover and the paper air filter.

To Change the Paper Air Filter:

1. Thoroughly clean the base of the air cleaner and the inside of the air cleaner cover.
2. Place the new paper filter in the cover.

3. Place the cover (with filter inside it) on the base of the air cleaner. Align the two screw holes in the cover with the two screws in the base of the air cleaner. Refer to Figure 5-9.

4. Turn the cover slightly clockwise and tighten the two screws.

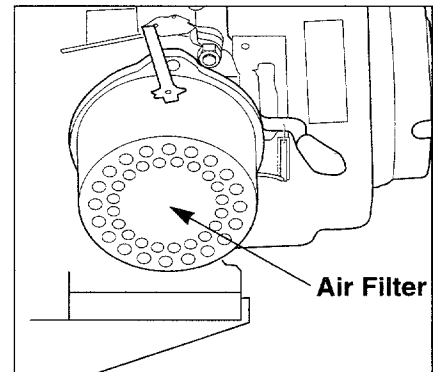

Figure 5-9: Engine Air Filter.

Engine Ignition System Maintenance

Your tiller's engine has a dependable, maintenance-free electronic ignition system. The system has no condenser or points. This means you do not have to tune up the engine. The only ignition system maintenance required is periodic changing of the spark plug. (See the following spark plug instructions.)

Spark Plug Maintenance

Check the spark plug at the beginning or the end of each season, or every 50 operating hours.

Clean the area around the spark plug hole before removing the spark plug.

1. Stop the engine, and wait for all moving parts to stop completely.

2. Disconnect the spark plug wire from the spark plug.

3. Use a 13/16" spark plug socket to remove the spark plug. The plug may be cleaned (do not sandblast or wire-brush it), and the gap set at .030" or a new spark plug may be used instead.

4. Install a new plug if the old plug's electrodes are pitted or burned or if the porcelain is cracked. See the Engine Manual for spark plug specifications.

Carburetor Adjustments

Your carburetor has been pre-set at the factory for best tiller performance. If your carburetor may need adjustment, contact your nearest authorized engine dealer.

Tightening Tiller Hardware



WARNING

Stop the engine, allow it to cool, disconnect the spark plug wire and prevent it from touching the spark plug before tightening any bolts, screws, or nuts.

Failure to do so could result in personal injury or property damage.

After the first two hours of tiller operation, check all fasteners (nuts, bolts, screws, pins, etc.) and tighten any that may have loosened. After this initial check, check those same fasteners after every ten hours of tiller operation.

Most of the fasteners on your tiller are in plain view. However, the following ones are not readily visible. Be sure to check them for tightness as well.

1. Rear End Cap Bolts— These three bolts are located at the rear end of the tiller transmission. Lift up the hood flap to view them.

2. Transmission Housing Cover Bolts— These four bolts are located on the top of the rear end of the tiller's transmission. You see them when you lift the hood flap.

Bolo Tines

As you use your tiller, the tines will gradually wear. They will become shorter, narrower and pointed, decreasing their ability to till effectively. Check the tines for wear several times a season, and replace badly worn tines to restore your tiller's effectiveness.

Removing and Installing Tine Assemblies



WARNING

Stop the engine, allow it to cool, disconnect the spark plug wire and prevent it from touching the spark plug before removing or installing a tine assembly.

Failure to comply could result in personal injury or property damage.

1. Use a 9/16" socket, 6" extension, a ratchet, and a 9/16" box end wrench to loosen the nut and bolt that secure the tine holder to the tine shaft. See Photo 5-11.

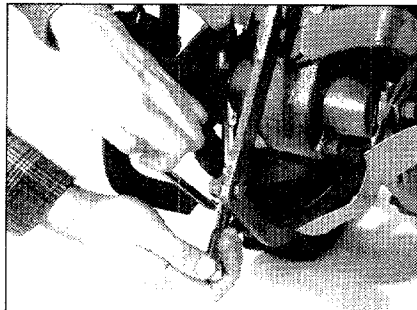

Photo 5-11: Removing tine assembly.

2. Use a rubber mallet to tap the tine holder loose.
3. Slide the tine assembly off the tine shaft.
4. Repeat Steps 1-through-3 above to remove the other tine assembly.
5. Installing the tine assembly is simply the reverse of its removal. First be sure to remove any rust, uneven spots or burrs from the tine shaft, using fine sandpaper. Then grease the tine shaft before reinstalling the tine assemblies. Tighten the hardware very securely.

Removing and Installing Individual Tines

1. Use two 9/16" box end wrenches to remove the two bolts, nuts and



WARNING

Stop the engine, allow it to cool, disconnect the spark plug wire and prevent it from touching the spark plug before removing or installing tiller tines.

Failure to comply could result in personal injury or property damage.

lockwashers that secure the tine to its tine holder. See Figure 5-12.

NOTE: If the nuts are rusted, apply penetrating oil to the bolt and nut. Let the oil soak in for several minutes before loosening the nut. Always loosen the nut rather than the bolt.

3. When installing individual tines, install them in the reverse order from which they were removed. All tine tips must point inward toward the transmission. Also be sure the cutting edges face so they will enter the soil first when the tiller is moving forward.

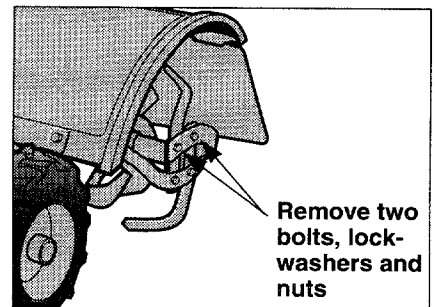

Figure 5-12: Removing one tine.

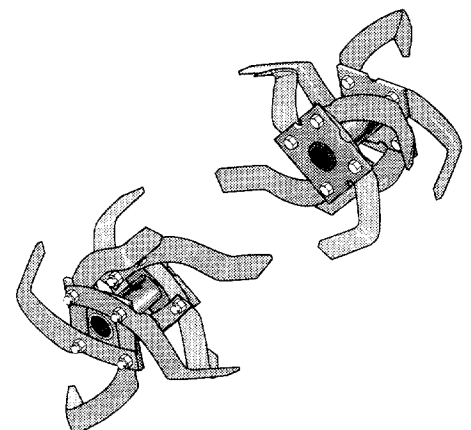

Figure 5-13: Install tines as above.

Checking and Adjusting Belt Tension

After the initial two hours of tiller operation, check the belt tension. After this initial check, check the belt tension every 10 operating hours. The same schedule should be followed after installing a new belt. If the belt is slipping (the tines and wheels don't rotate as fast as when new, or they may even stop turning when the engine is running at full speed), perform the belt tension check to see if the belt needs to be tightened. If you find you can not bring the Forward Clutch Bail all the way up to the bottom of the upper handlebars, you will need to loosen the belt tension.



WARNING

Stop the engine, allow it to cool down, disconnect the spark plug wire and prevent it from touching the spark plug before checking the belt tension.

Failure to comply could result in personal injury or property damage.

1. Lift the Forward Clutch Bail up and hold it to the bottom of the handlebars.
2. Measure the length of the clutch bail spring with a ruler. Refer to Figure 5-14.
3. If the belt tension is correct, the length of the spring should be approximately 1-7/8".
4. If the spring is too short, the belt tension will be too loose. If the spring is too long, the belt tension will be too tight.
5. To adjust the length of the spring, release the Forward Clutch Bail. Screw the threaded adjuster counterclockwise (as viewed from the operator's position) to increase the length of the spring or clock-

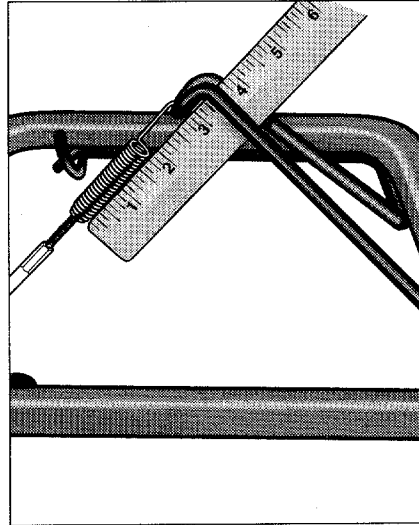

Figure 5-14: Measure the length of the Clutch Bail Spring to check for correct belt tension (1-7/8").

wise (as viewed from the operator's position) to decrease the length of the spring.

NOTE: If you have difficulty turning the adjuster by hand, have an assistant hold the Forward Clutch Bail to the handlebars while you insert a flat-tipped screwdriver into the clutch bail spring. Engage the tip of the screwdriver with the slot in the screw head that is inside the clutch bail spring. While you turn the screw, keep the Forward Clutch Cable from turning by gripping the adjuster on its upper end with a pliers. See Photo 5-14A.

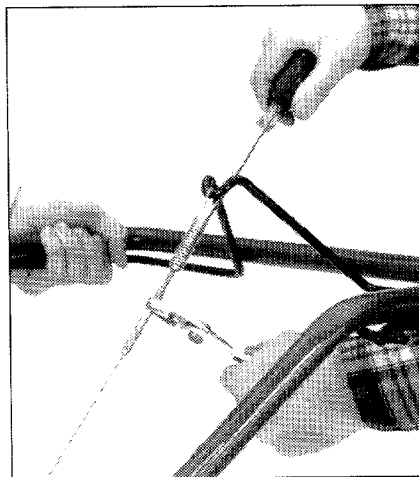

Photo 5-14A: Adjusting the length of the Clutch Bail Spring.

Belt Removal and Replacement



WARNING

Stop the engine, let it cool down, disconnect the spark plug wire and prevent it from touching the spark plug before changing the belt.

Failure to comply could result in personal injury or property damage.

To Remove the Belt:

1. Use a 3/8" wrench to remove the bolt that attaches the belt cover to the tiller. Slide the belt cover up the cable slightly so it is out of the way. See Photo 5-15.

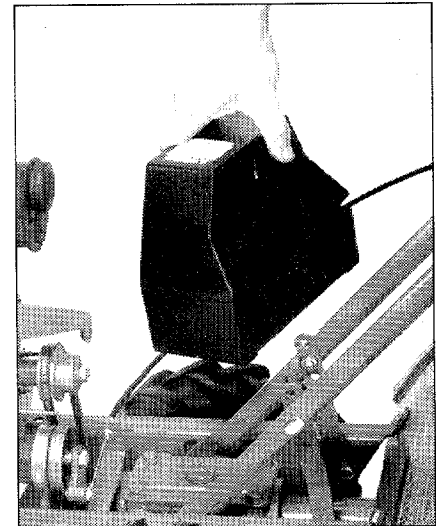

Photo 5-15: Remove belt cover.

2. Push down on the upper section of the belt to create some belt slack when you move the belt off the transmission pulley. Reach underneath the tiller and move the belt forward, off the transmission pulley. Refer to Photo 5-16.
3. From above, lift the belt up and off the engine pulley. You need to guide the lower portion of the belt as you're removing it so that it doesn't hang up on anything.

To Install the Belt:

1. Insert the new belt down, in back of the engine pulley and in front of the transmission.

2. Work the belt over the transmission pulley. Make sure the belt goes in the groove in the transmission pulley.

3. Loop the upper section of the belt around the engine pulley. Make sure the belt goes in the groove in the engine pulley. Also be sure the belt goes between the engine pulley and the wire belt

guide on each side of the pulley. Refer to Photo 5-18.

4. Slide the belt cover down the Forward Clutch Cable and reinstall it on the tiller.

5. Check the belt tension. See "Checking and Adjusting Belt Tension" for specific instructions.

NOTE: If you've installed a new belt, remember to check and readjust its tension after the first two hours of operation.

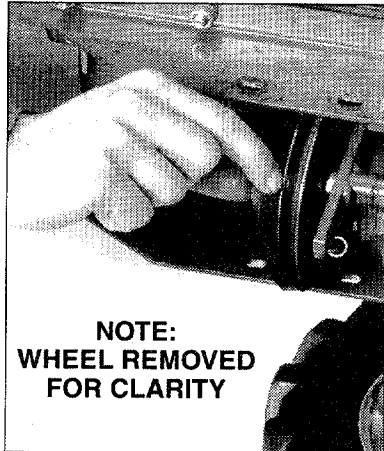

Photo 5-16: Moving the belt off the transmission pulley.

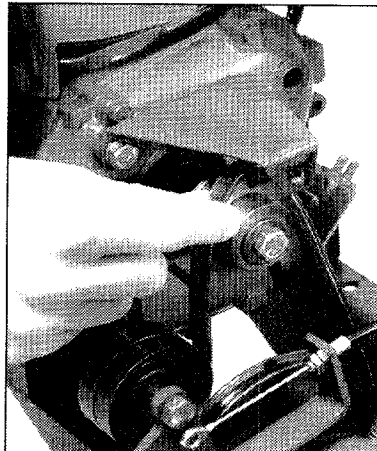

Photo 5-17: Moving the belt off the engine pulley.

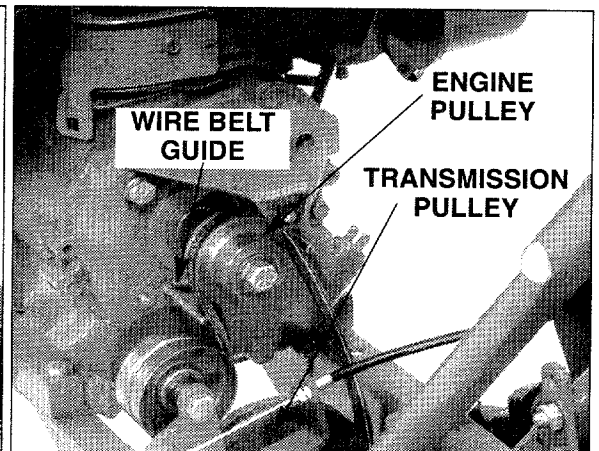

Photo 5-18: The new drive belt installed.

Forward Clutch Bail Adjustment

See "Checking and Adjusting Belt Tension" in this section. When the belt has the correct amount of tension, the Forward Clutch mechanism should be properly adjusted.

If, after adjusting the belt tension, the Forward Clutch mechanism does not operate correctly, please contact our Technical Service Department for further instructions.



WARNING

Stop the engine, allow it to cool, disconnect the spark plug wire and prevent it from touching the spark plug before removing or installing the Forward Clutch Cable.

Failure to comply could result in injury or property damage.

Removing and Installing the Forward Clutch Cable

To Remove Forward Clutch Cable:

1. Unhook the spring that is on the upper end of the Forward Clutch Cable from the Forward Clutch Bail.

2. Use a 3/8" wrench to remove the bolt that attaches the belt cover to the tiller. Slide the belt cover up the cable until it is out of the way.

3. Use a pair of needle nose pliers to carefully remove the klip ring from the clevis pin on the idler lever (Photo 5-19).

4. Use one 7/16" and one 3/8" open end wrench to loosen the locknut on the lower end of the Forward Clutch Cable sheath where it attaches to the cable mounting bracket (refer to Photo 5-20).

5. Push the Forward Clutch Cable forward to free it from the cable mounting bracket.

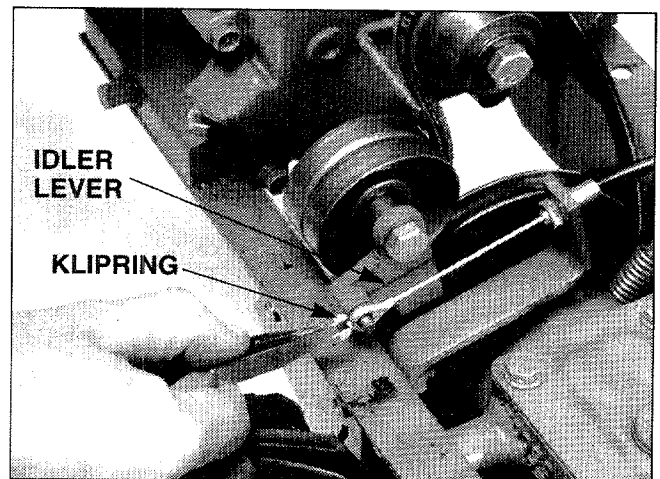

Photo 5-19: Removing the klip ring.

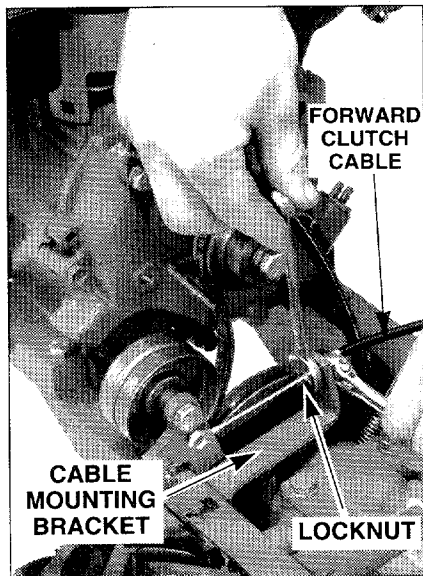

Photo 5-20: Loosening the Forward Clutch Cable.

6. Pull downward on the upper end of the Forward Clutch Cable sheath where the connector fits into the cable bracket on the upper end of the lower handlebar. Guide the cable out of the slot in the cable bracket. See Photo 5-21.

To Install Forward Clutch Cable:

1. Place the lower end of the Forward Clutch Cable into the cable mounting bracket and use one 7/16" and one 3/8" open end wrench to securely fasten it to the cable mounting bracket. Refer to Photo 5-22.
2. Place the lower end of the Forward Clutch Cable over the clevis pin on the left-hand side of the idler lever. See Photo 5-22.
3. Use a pair of needle nose pliers to place the klip ring on the clevis pin (Photo 5-19).
4. Hook the spring on the upper end of the Forward Clutch Cable to the Forward Clutch Bail.
5. Pull downward on the upper end of the black cable sheath. Slide the Forward Clutch Cable into the slot in the cable bracket that is on the upper end of the lower handlebar. Center the connector on the upper end of the cable sheath in the hole in the cable bracket and push the connector into the hole until it snaps into place. See Photo 5-21.

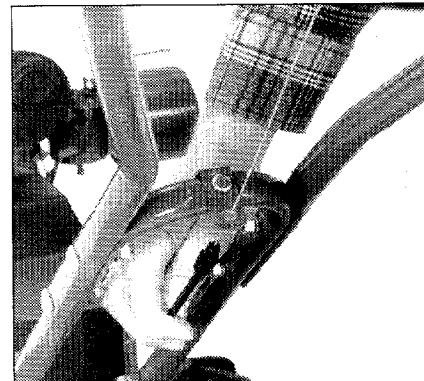

Photo 5-21: Remove the Forward Clutch Cable from the cable bracket.



Photo 5-22: Installing the lower end of the Forward Clutch Cable.

Tiller Storage

Whenever you don't intend to use your tiller for 30 days or longer, you should perform the following steps to ensure that it will start easily and perform properly when removed from storage.

1. To prevent harmful gum deposits from forming in the fuel tank or carburetor, gasoline should be drained out or treated with a fuel stabilizer (such as STA - BIL). Refer to the "Storage" instructions in your Engine Owner Manual for specific instructions.

NOTE: If Gasohol has been used in the engine, refer to your Engine Owner's Manual for specific instructions.

2. Change the engine oil while the engine is still warm. See "Changing Engine Oil" in this section for full instructions.
3. Clean any debris off the tiller.
4. Lubricate the tiller. See this section for specific instructions.

5. Store tiller indoors in a cool, dry environment.

6. The end of the gardening season is a good time to order any replacement or service parts you may need in order to have your tiller in top shape for next year.



DANGER

Gasoline is highly flammable and its vapors are explosive. Follow these safety practices to prevent injury or property damage from fire or explosion.

- Let engine and muffler cool at least 2 minutes before draining fuel tank.
- Do not allow open flames, sparks, and matches, or permit smoking in fueling area.
- Wipe up spills and push the tiller away from spilled fuel.
- Use only an approved fuel container and store it safely from children.
- Do not store gasoline in an area where its vapors could reach an open flame or spark, or where ignition sources are near (such as hot water and space heaters, furnaces, clothes dryers, stoves, motors, etc.)

TROUBLESHOOTING

Before performing any of the procedures in this Troubleshooting Chart, refer to the appropriate information contained in this Manual for the correct safety precautions and operating or maintenance procedures. Contact your local authorized Engine Service Dealer for engine service. Contact your local authorized tiller dealer or the Factory for service problems with the machine.

PROBLEM	POSSIBLE CAUSE	CORRECTION
Engine Does Not Start.	<ol style="list-style-type: none"> 1. Spark plug wire disconnected. 2. Fuel tank empty. 3. Stale gasoline. 4. Incorrect choke setting. 5. Dirty air filter. 6. Defective or incorrectly gapped spark plug. 7. Carburetor out of adjustment. 	<ol style="list-style-type: none"> 1. Reconnect wire. 2. Add gasoline. 3. Drain gasoline and add fresh gasoline. 4. Put choke in correct setting (Page 14). 5. Replace (Page 26). 6. Inspect spark plug (Page 26). 7. See Engine Service Dealer.
Engine Runs Poorly.	<ol style="list-style-type: none"> 1. Bad spark plug. 2. Incorrect choke setting. 3. Dirty air filter(s). 4. Carburetor out of adjustment. 5. Stale gasoline. 6. Dirt or water in fuel tank. 7. Engine cooling system clogged. 	<ol style="list-style-type: none"> 1. Inspect spark plug (Page 26). 2. Put choke in correct setting (Page 14). 3. Replace (Page 26). 4. See Engine Service Dealer. 5. Drain gasoline and add fresh gasoline. 6. See Engine Service Dealer. 7. Clean debris guard and fins.
Engine Overheats.	<ol style="list-style-type: none"> 1. Engine cooling system clogged. 2. Carburetor out of adjustment. 3. Oil level is low. 	<ol style="list-style-type: none"> 1. Clean debris guard and fins. 2. See Engine Service Dealer. 3. Check and add oil (Page 23).
Engine does not shut off.	<ol style="list-style-type: none"> 1. Defective engine throttle lever. 	<ol style="list-style-type: none"> 1. See Engine Service Dealer.

Tiller & Engine Specifications

TILLER

Height

Without Handlebars	.21¼"
With Handlebars in lowest position	.37¼"
With Handlebars in highest position	.46¼"

Length

With Handlebars in lowest position	.53½"
Without Handlebars	.36¼"

Width

Hood Width	.15¼"
Tilling Width	.14"
Wheel Width	.13⅝" - 14¼"
Width at top of Handlebars	.18"
Weight (w/o oil or gas)	.117 pounds

Transmission Gear Oil Specifications

Small Top-Offs: SAE 140, SAE 85W-140, or SAE 80W-90 weight gear oil with an API rating of either GL-4 or GL-5.

Full Replacement: SAE 140 or SAE 85W-140 weight gear oil with an API rating of GL-4 only.

ENGINE

Engine Type

Tecumseh 3 Horsepower, single cylinder air cooled, horizontal crankshaft, with manual choke and solid state ignition.

Fuel Tank Capacity

2 Quarts.

Fuel Specifications

Unleaded regular gasoline. See Engine Owner's Manual for other gasoline recommendations. DO NOT use Leaded gasoline.

Engine Oil Capacity

Approximately 21 ounces (1¼ pints). Important: Always be sure the oil level is at the point of overflowing from the oil filler tube.

Spark Plug

See your Engine Owner's Manual for the recommended spark plug type.

Spark Plug Gap

.030"

Ignition System

Solid State Electronic Ignition (no points or condenser required).

A

Adjustments See Maintenance/Repairs
 Air Cleaner, 26
 Assembly Steps, 8-11
 Authorized Engine Service, 4

B

Bail, Forward Clutch, 13
 Belt
 Adjusting, 28
 Replacing, 28
 Tension Check, 28
 Bolo Tines, 27
 Break-In Operation, 15

C

Cable, Forward Clutch, 29
 Carburetor Adjustments, 26
 Choke, Engine, 14
 Claims, Freight, 8
 Composting, Power, 19
 Cooling System Maintenance, 26
 Controls, Tiller and Engine, 12-14
 Crop Residues, 19
 Cultivating, 19

D

Decals, 7
 Depth Regulator Lever, 14
 Depths, Tilling, 17
 Drive Belt (see Belt Tension
 and Belt Removal), 28-29

E

Engine
 Air Cleaner, 26
 Choke Lever, 14
 Cooling System, 26
 Controls, 14
 Fuel (gasoline), 32
 Oil, 11, 32
 Recoil Starter, 14
 Serial Number, 3
 Service Outlets, 4
 Spark Plug, 22, 26, 32
 Starting, 16
 Stopping, 17
 Storage, 30
 Throttle Lever, 14, 16,

F

Fins, Engine Cooling, 26
 Footprints, 18
 Forward Clutch Bail, 13, 29
 Frame Weights, 19

Freight Damage, 8
 Fuel, 32

G

Gasoline, 16, 32
 Gear Oil, 24, 25, 32
 Grease, 23
 Guiding the Tiller, 17

H

Handlebar Height Adjustment, 9, 14
 Hillside (Slope) Tilling, 20

I

Ignition System, 26

J, K**L**

Leaks, Oil, 26
 Loading/Unloading, 21
 Lubrication, 22, 23

M

Maintenance/Repairs, 22-31
 Air Cleaner, 26
 Carburetor, 26
 Engine Cooling System, 26
 Engine Oil, 24
 Forward Clutch Bail, 13
 Ignition, 26
 Lubrication, 23
 Nuts/Bolts, 27
 Off-Season Storage, 30
 Schedule, 22
 Spark Arrester, 5
 Spark Plug, 26
 Troubleshooting, 31
 Forward Clutch Bail Cable, 29
 Model Number, 3
 Motor Oil, 11, 23-24, 32

N

Nuts/Bolts, 27

O

Off-Season Storage, 30
 Oil, Motor
 Adding, 11, 23
 Changing, 24
 Checking, 23-24
 Oil, Transmission Gear
 Adding, 25

Changing, 25
 Checking, 24
 Type, 25, 32
 Oil Leaks, 26
 Operating the Tiller, 17-20
 Ordering Tiller Parts, 4

P

Pins, Wheel Drive, 12
 Power Composting, 19
 Pre-Start Checklist, 16

Q**R**

Reversing the Tiller, 17
 Repairs and Adjustments, 22-31
 Rules, Safety, 5-7

S

Safety Rules, 5-7
 Seedbed Preparation, 18
 Serial Number, 3
 Sloping Ground, 20
 Spark Plug, 22, 26, 32
 Specifications (Tiller & Engine), 32
 Starting and Stopping Engine, 16-17
 Starting the Tiller, 17
 Stopping the Tiller, 17
 Storage, 30

T

Terrace Gardening, 20
 Throttle Lever (engine), 14
 Tightening Nuts/Bolts, 27
 Tiller Operation, 17-20
 Tiller Serial Number, 3
 Tines (bolo), 27
 Travel Position (depth regulator), 14
 Turning Around, 18

U

Unloading/Loading, 21
 Untangling Tines, 20
 Uphill Tilling, 20

V**W, X, Y, Z**

Weights, Frame, 19
 Wheel Drive Pins, 9, 12-13

Notes

A series of horizontal dashed lines for writing notes.

For customer assistance, contact your nearest authorized dealer or:

GARDEN WAY INCORPORATED • 1 Garden Way • Troy, New York U.S.A. 12180
Customer Service: 1-800-437-8686 • Technical Service: 1-800-520-5520 • Parts Service: 1-800-648-6776 • FAX: (518) 391-7332

Outside the U.S.A. and Canada:
Customer Service: (518) 391-7007 • Technical Service: (518) 391-7008 • Parts Service: (518) 391-7006 • FAX: (518) 391-7332