

YARD-MAN™

by MTD®

OWNER'S GUIDE

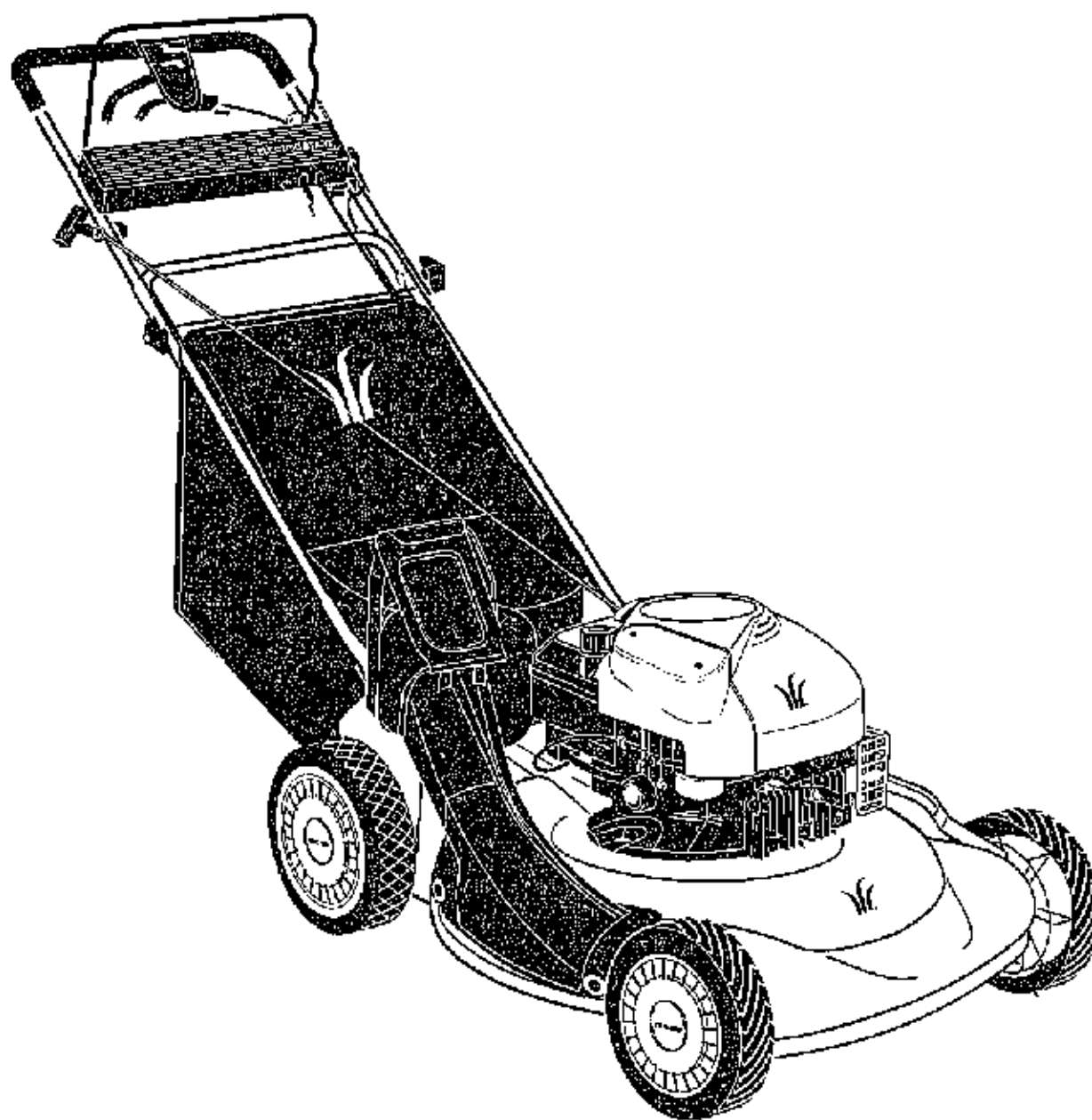

Model Shown E979

Model Series
959 - 979
E979



IMPORTANT: READ SAFETY RULES AND INSTRUCTIONS CAREFULLY

Warning: This unit is equipped with an internal combustion engine and should not be used on or near any unimproved forest-covered, brush-covered or grass-covered land unless the engine's exhaust system is equipped with a spark arrester meeting applicable local or state laws (if any). If a spark arrester is used, it should be maintained in effective working order by the operator. In the State of California the above is required by law (Section 4442 of the California Public Resources Code). Other states may have similar laws. Federal laws apply on federal lands. A spark arrester for the muffler is available through your nearest engine authorized service dealer or contact the service department, P.O. Box 368022 Cleveland, Ohio 44136-9722.

MTD PRODUCTS INC. P.O. BOX 368022 CLEVELAND, OHIO 44136-9722

SECTION 1: SLOPE GAUGE

USE THIS PAGE AS A GUIDE TO DETERMINE SLOPES WHERE YOU MAY NOT OPERATE SAFELY.

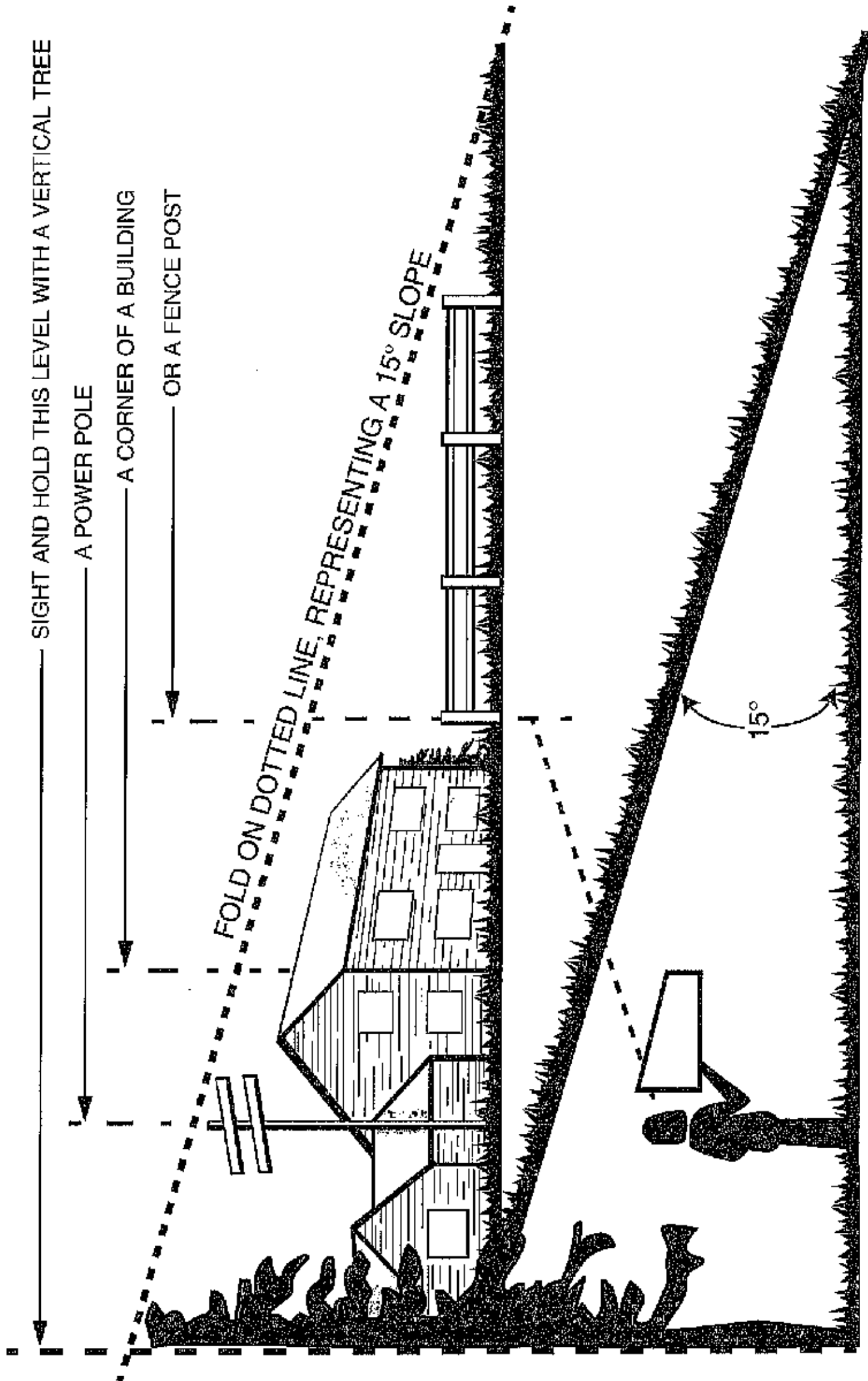

WARNING

Do not mow on inclines with a slope in excess of 15 degrees (a rise of approximately 2-1/2 feet every 10 feet). A riding mower could overturn and cause serious injury. If operating a walk-behind mower on such a slope, it is extremely difficult to maintain your footing and you could slip, resulting in serious injury.
Operate RIDING mowers up and down slopes, never across the face of slopes.
Operate WALK-BEHIND mowers across the face of slopes, never up and down slopes.

SECTION 2: IMPORTANT SAFE OPERATION PRACTICES



WARNING: THIS SYMBOL POINTS OUT IMPORTANT SAFETY INSTRUCTIONS WHICH, IF NOT FOLLOWED, COULD ENDANGER THE PERSONAL SAFETY AND/OR PROPERTY OF YOURSELF AND OTHERS. READ AND FOLLOW ALL INSTRUCTIONS IN THIS MANUAL BEFORE ATTEMPTING TO OPERATE YOUR LAWN MOWER. FAILURE TO COMPLY WITH THESE INSTRUCTIONS MAY RESULT IN PERSONAL INJURY. WHEN YOU SEE THIS SYMBOL, HEED ITS WARNING.



DANGER: Your lawn mower was built to be operated according to the rules for safe operation in this manual. As with any type of power equipment, carelessness or error on the part of the operator can result in serious injury. This lawn mower is capable of amputating hands and feet and throwing objects. Failure to observe the following safety instructions could result in serious injury or death.

1. GENERAL OPERATION

- Read this owner's guide carefully in its entirety before attempting to assemble this machine. Read, understand, and follow all instructions on the machine and in the manual(s) before operation. Be completely familiar with the controls and the proper use of this machine before operating it. Keep this manual in a safe place for future and regular reference and for ordering replacement parts.
- Your rotary mower is a precision piece of power equipment, not a plaything. Therefore, exercise extreme caution at all times. Your unit has been designed to perform one job: to mow grass. Do not use it for any other purpose.
- Never allow children under 14 years old to operate a power mower. Children 14 years old and over should only operate mower under close parental supervision. Only responsible individuals who are familiar with these rules of safe operation should be allowed to use your mower.
- Keep the area of operation clear of all persons, particularly small children and pets. Stop engine when they are in the vicinity of your mower to help prevent blade contact or thrown object injury. Although the area of operation should be completely cleared of foreign objects, an object may have been overlooked and could be accidentally thrown by the mower in any direction and cause serious personal injury to the operator or any others allowed in the area.
- Thoroughly inspect the area where the equipment is to be used. Remove all stones, sticks, wire, bones, toys and other foreign objects which could be picked up and thrown by the mower in any direction and cause serious personal injury to the operator or any others allowed in the area. Plan your mowing pattern to avoid discharge of material toward roads, sidewalks, bystanders and the like. To help avoid a thrown objects injury, keep children, bystanders and helpers at least 75 feet from the mower while it is in operation.
- Always wear safety glasses or safety goggles during operation or while performing an adjustment or repair, to protect eyes from foreign objects that may be thrown from the machine in any direction.
- Wear sturdy, rough-soled work shoes and close-fitting slacks and shirts. Shirts and pants that cover the arms and legs and steel-toed shoes are recommended. Do not wear loose fitting clothes or jewelry. They can be caught in moving parts. Never operate a unit in bare feet, sandals, slippery or light weight (e.g. canvas) shoes.
- Do not put hands or feet near or under rotating parts. Keep clear of discharge opening at all times as the rotating blade can cause injury.
- Many injuries occur as a result of the mower being pulled over the foot during a fall. Do not hang on to the mower if you are falling; release the handle immediately.
- Never pull the mower toward you while you are walking. If you must back the mower away from a wall or obstruction first look down and behind, and then follow these steps:
 - Step back from the mower to fully extend your arms.
 - Be sure you are well balanced with sure footing.
 - Pull the mower back slowly, no more than half way toward you.
 - Repeat these steps as needed.
- Do not operate the mower while under the influence of alcohol or drugs.
- Do not engage the self-propelled mechanism on units so equipped while starting engine.
- The blade control handle is a safety device. Never attempt to bypass its operation. Doing so makes the safety device inoperative and may result in personal injury through contact with the rotating blade. The blade control handle must operate easily in both directions and automatically return to the disengaged position when released.

- Never operate the mower in wet grass. Always be sure of your footing. A slip and fall can cause serious personal injury. Keep a firm hold on the handle and walk, never run. If you feel you are losing your footing, **RELEASE THE BLADE CONTROL HANDLE IMMEDIATELY** and the blade will stop rotating within three seconds.
- Mow only in daylight or good artificial light.
- Stop the blade when crossing gravel drives, walks or roads.
- If the equipment should start to vibrate abnormally, stop the engine and check immediately for the cause. Vibration is generally a warning of trouble.
- Shut the engine off and wait until the blade comes to a complete stop before removing the grass catcher or unclogging the chute. The cutting blade continues to rotate for a few seconds after the engine is shut off. Never place any part of the body in the blade area until you are sure the blade has stopped rotating.
- Never operate mower without proper guards, grass catcher, plates or other safety protective devices in place.
- Muffler and engine become hot and can cause a burn. Do not touch.
- Only use accessories approved for this machine by the manufacturer. Read, understand, and follow all instructions provided with the approved accessory.
- If situations occur which are not covered in this manual, use care and good judgment. Contact your dealer for assistance. Telephone 1-800-800-7310 for the name of your nearest dealer.

2. SLOPE OPERATION

For your safety, use the slope gauge included as part of this manual to measure slopes before operating this unit on a sloped or hilly area. If the slope is greater than 15 degrees as shown on the slope gauge, do not operate this unit on that area or serious injury could result.

DO:

- Mow across the face of slopes; never up and down. Exercise extreme caution when changing direction on slopes.
- Watch for holes, ruts, hidden objects, or bumps. Tall grass can hide obstacles.
- Always be sure of your footing. A slip and fall can cause serious personal injury. If you feel you are losing your balance release the blade control handle immediately and the blade will stop in less than 3 seconds.

DO NOT:

- Do not mow near drop-offs, ditches or embankments. The operator could lose footing or balance.
- Do not mow slopes greater than 15 degrees as shown on the slope gauge.

- Do not mow on wet grass. Reduced footing could cause slipping.

3. CHILDREN

Tragic accidents can occur if the operator is not alert to the presence of children. Children are often attracted to the mower and the mowing activity. Never assume that children will remain where you last saw them.

- Keep children out of the mowing area and under the watchful care of a responsible adult other than the operator.
- Be alert and turn mower off if a child enters the area.
- Before and while moving backwards, look behind and down for small children or other objects.
- Never allow children under age 14 to operate the mower. Children 14 years of age and above should read and understand the operation instructions and safety rules in this manual.
- Use extreme care when approaching blind corners, shrubs, trees, or other objects that may obscure your vision of a child or hazard.

4. SERVICE

- Use extreme care in handling gasoline and other fuels. They are extremely flammable and the vapors are explosive.
- Use only an approved gasoline container.
- Never remove gas cap or add fuel while the engine is running. Allow engine to cool at least two minutes before refueling.
- Replace gasoline cap securely and wipe off any spilled gasoline before starting the engine as it may cause a fire or explosion.
- Extinguish all cigarettes, cigars, pipes and other sources of ignition.
- Never refuel machine indoors because flammable vapors will accumulate in the area.
- Never store the machine or fuel container inside where there is an open flame or spark such as a gas water heater, space heater, or furnace.
- Never run an engine inside a closed area.
- To reduce fire hazard, keep mower free of grass, leaves, or other debris build-up. Clean up oil or fuel spillage. Allow mower to cool at least 5 minutes before storing.
- Before cleaning, repairing, or inspecting, make certain the blade and all moving parts have stopped. Disconnect the spark plug wire, and keep the wire away from the spark plug to prevent accidental starting.
- Check the blade and engine mounting bolts at frequent intervals for proper tightness. Also, visually inspect blade for damage (e.g., bent, cracked or worn). Replace with blade which meets original equipment specifications listed in this manual.
- Keep all nuts, bolts, and screws tight to be sure the equipment is in safe working condition.

- Never tamper with safety devices. Check their proper operation regularly.
- After striking a foreign object, stop the engine, remove the wire from the spark plug, and thoroughly inspect the mower for any damage. Repair the damage before starting and operating the mower.
- Never attempt to make a wheel or cutting height adjustment while the engine is running.
- Grass catcher components are subject to wear, damage and deterioration, which could expose

moving parts or allow objects to be thrown. For safety protection, frequently check components and replace with manufacturer's recommended parts, when necessary.

- Mower blades are sharp and can cut. Wrap the blade(s) or wear gloves, and use extra caution when servicing them.
- Do not change the engine governor setting or overspeed the engine. Excessive engine speeds are dangerous.



WARNING: The engine exhaust from this product contains chemicals known to the state of California to cause cancer, birth defects or other reproductive harm



WARNING - YOUR RESPONSIBILITY: Restrict the use of this power machine to persons who read, understand and follow the warnings and instructions in this manual and on the machine.

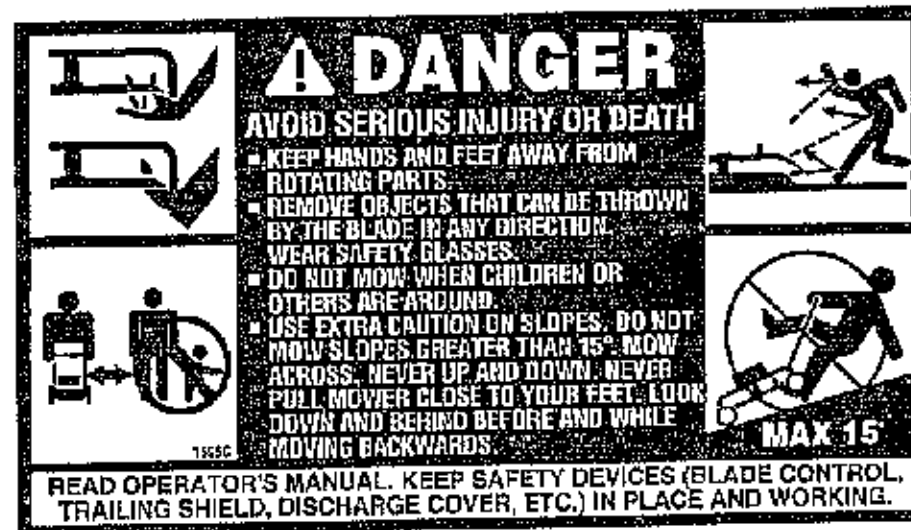

Figure 1 Safety Labels Found On Lawn Mower

SECTION 3: FINDING MODEL NUMBER

This Owner's Guide is an important part of your new lawn mower. It will help you assemble, prepare and maintain your mower. Please read and understand what it says.

Before you start to prepare your mower for its first use, please locate the model plate and copy the information from it in this Owner's Guide. The information on the model plate is very important if you need help from your dealer or the MTD customer support department.

- Every mower has a model plate. You can locate it by standing behind the unit in the operating position and looking down at the cutting deck.

- The model plate will look like Figure 2.

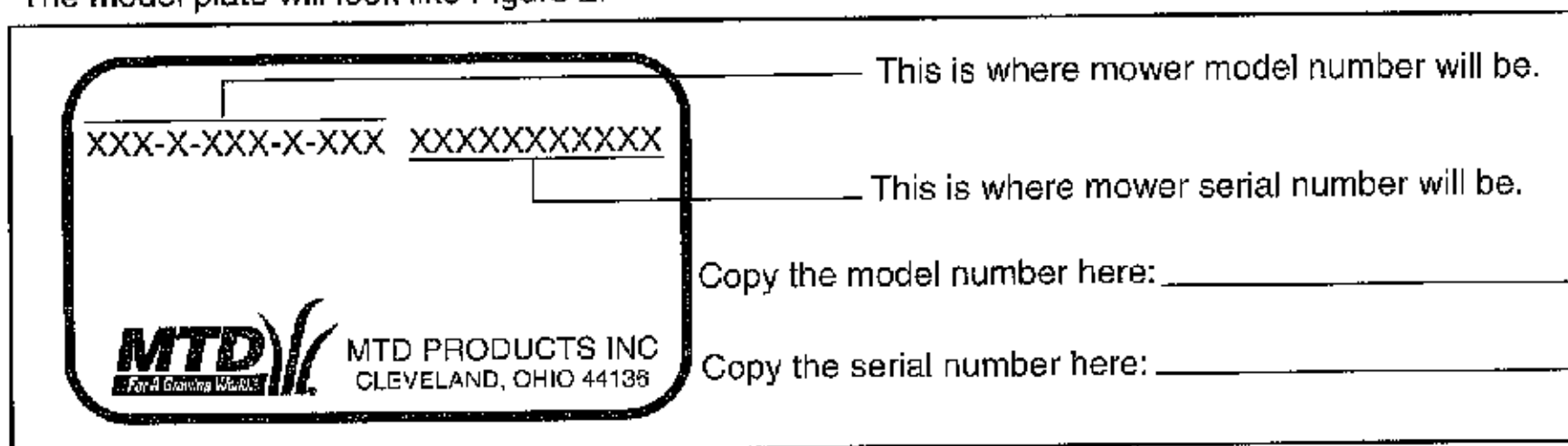

Figure 2

SECTION 4: CALLING CUSTOMER SUPPORT

If you have any question regarding assembly, controls, operation or maintenance of this mower, please call the Yardman Customer Support Department at

1-800-800-7310

Before you call, make sure that you have both the model and serial numbers of your mower ready. By doing so, you help the Customer Support Representative give you faster service. To find your mower's model and serial numbers, see the preceding section.

SECTION 5: UNPACKING INSTRUCTIONS

REMOVE UNIT FROM CARTON

(See Figure 3.)

- Remove staples, break glue on top flaps, or cut tape at carton end and peel along top flap to open carton.
- Remove loose parts if included with unit (i.e., owner's manual, etc.).
- Cut along dotted lines and lay carton down flat.
- Remove packing material.
- Roll or slide unit out of carton. Check carton thoroughly for loose parts.

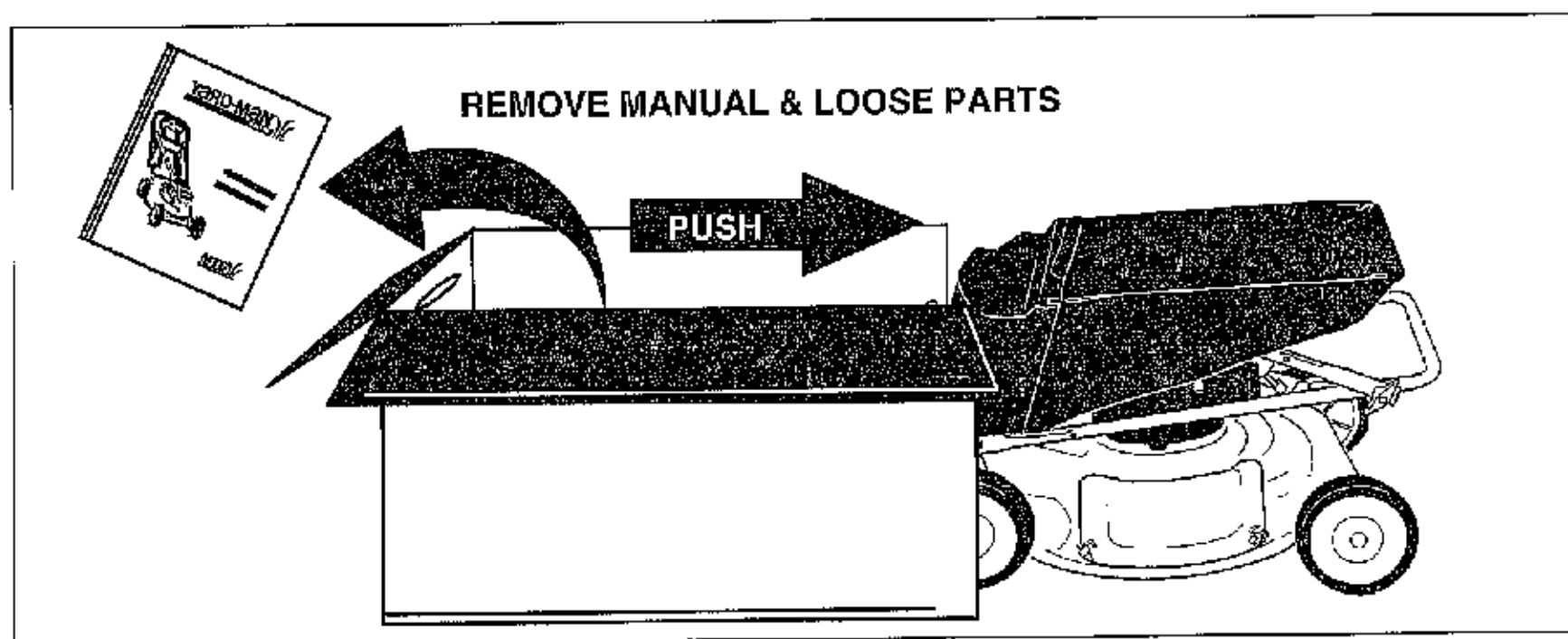

Figure 3

DISCONNECT SPARK PLUG WIRE

Before setting up your lawn mower, disconnect the spark plug wire from the spark plug, and ground it against the engine by attaching rubber boot to a bolt or metal clip to the grounding post on the engine. See Figure 4.

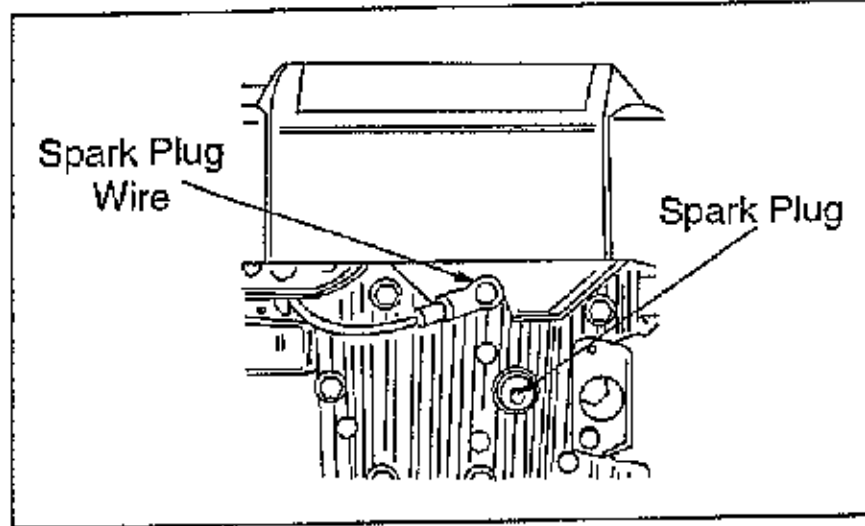

Figure 4

SECTION 6: SET-UP INSTRUCTIONS

ITEMS REQUIRED FOR ASSEMBLY

- Pair of Pliers (Not necessary, but helpful)
- Motor Oil
- Fresh Gasoline

IMPORTANT: This unit is shipped WITHOUT GASOLINE or OIL in the engine. Be certain to service engine with gasoline and oil as instructed in the separate engine manual before operating your mower.

NOTE: Reference to right or left hand side of the mower is observed from the operating position.

SET UP YOUR LAWN MOWER

Follow steps 1 through 9 to set up your lawn mower.

Step 1. Remove grass bag (model 970-979 only) from unit and set it out of the way.

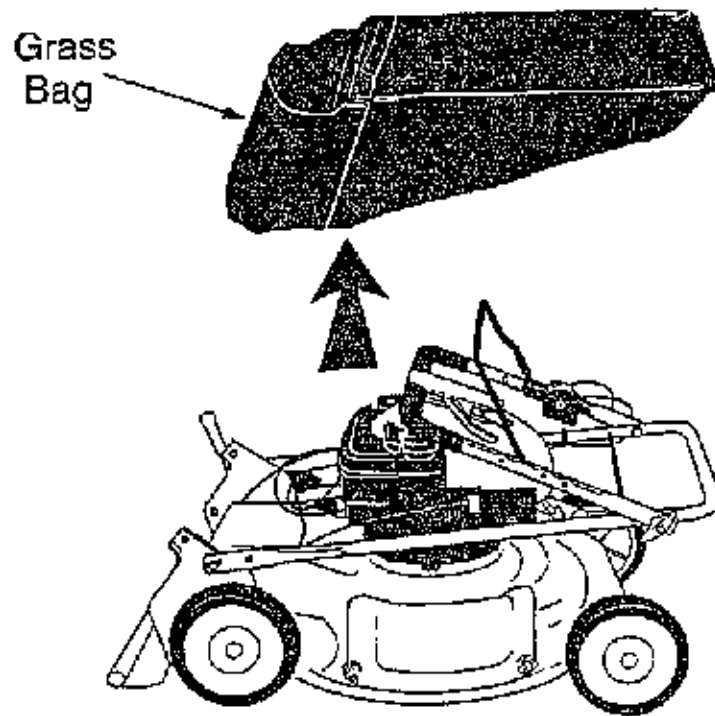

Step 2. Lift upper handle. Align it with lower handle.

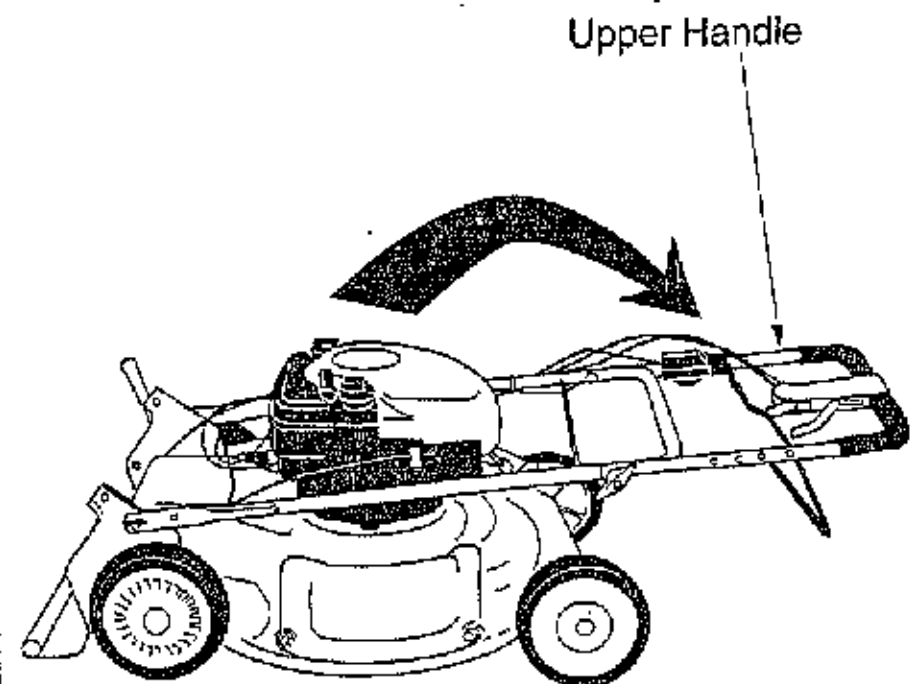

Step 3. Tighten wing nuts.

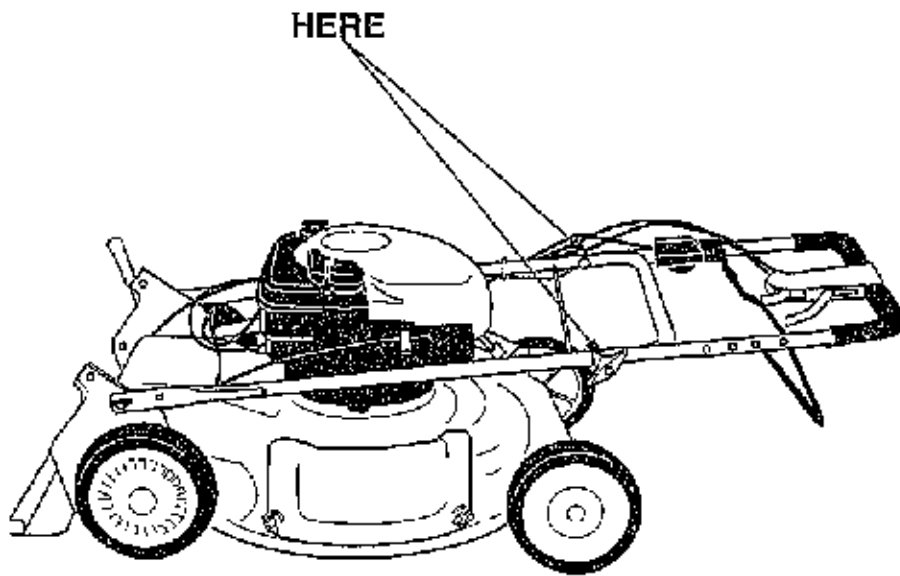

Step 4. Raise complete handle assembly until it clicks into place. Make sure not to kink the control cables.

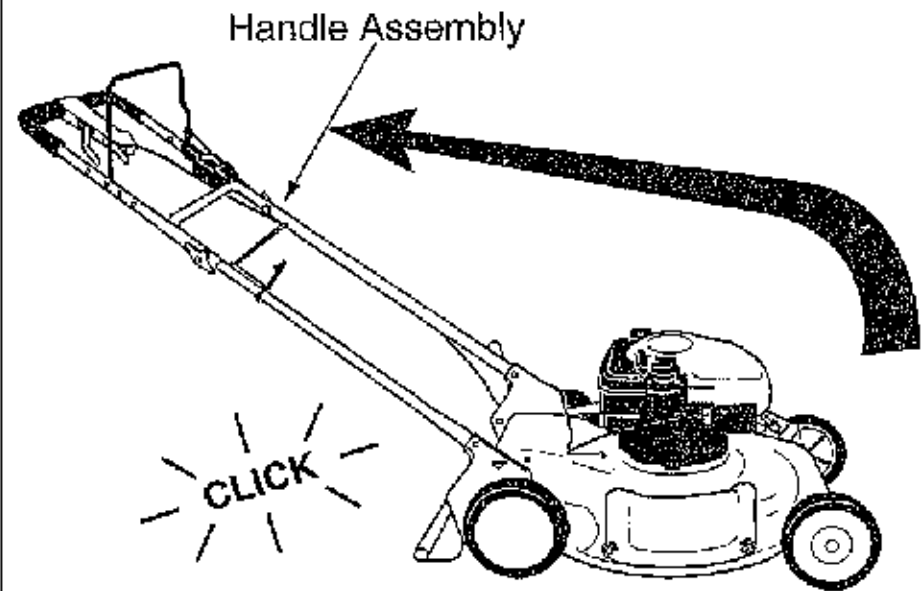

Step 5. Pinch lower handle against mounting bracket with pliers.

Step 6. Move hairpin clip from outer to inner hole on left and right handle mounting brackets.

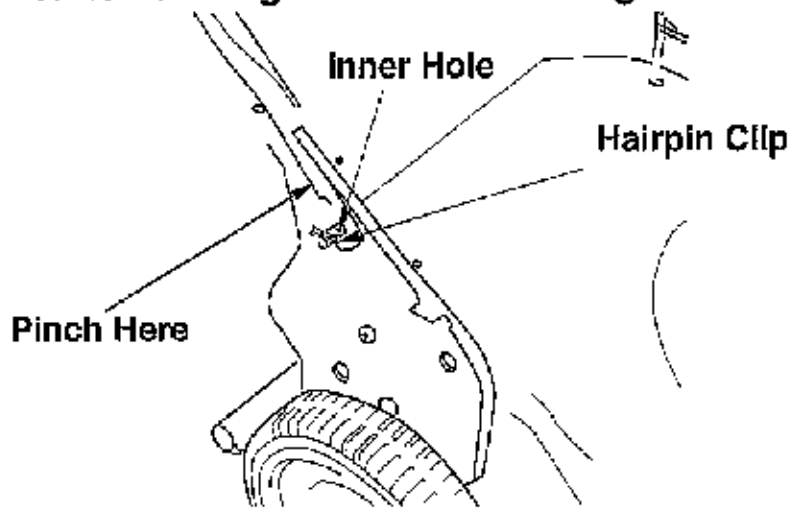

Step 7. Attach control cables to handle with pull ties found on the handle.

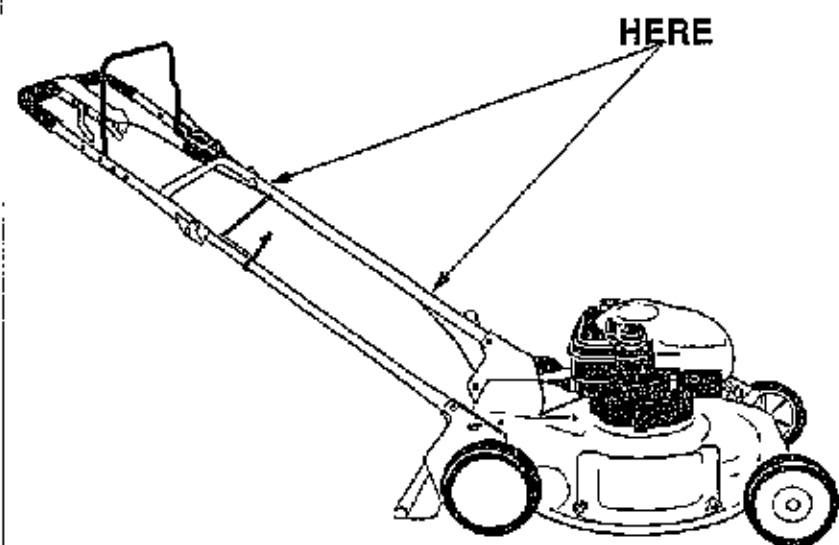

Step 8. Squeeze the blade control handle against the upper handle and pull out the starter rope slowly.

Step 9. Thread the starter rope into the rope guide.

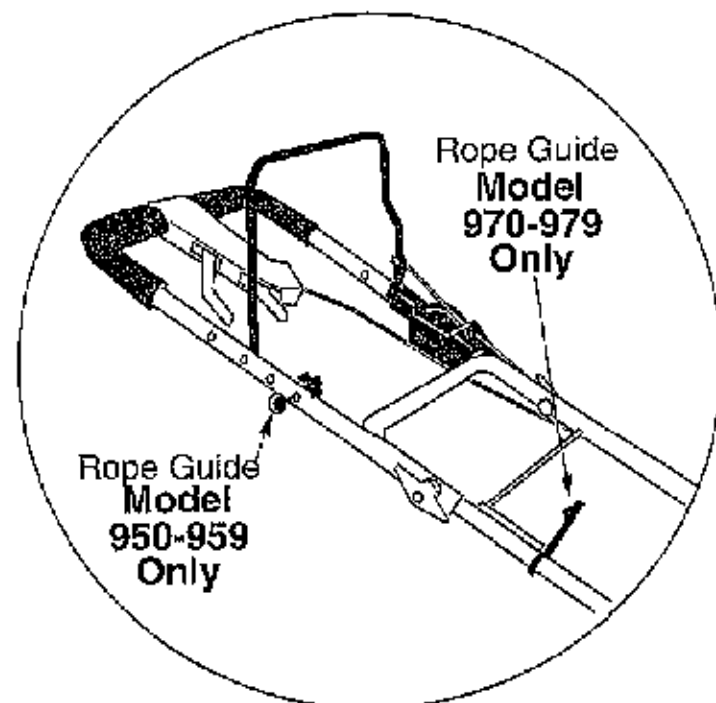
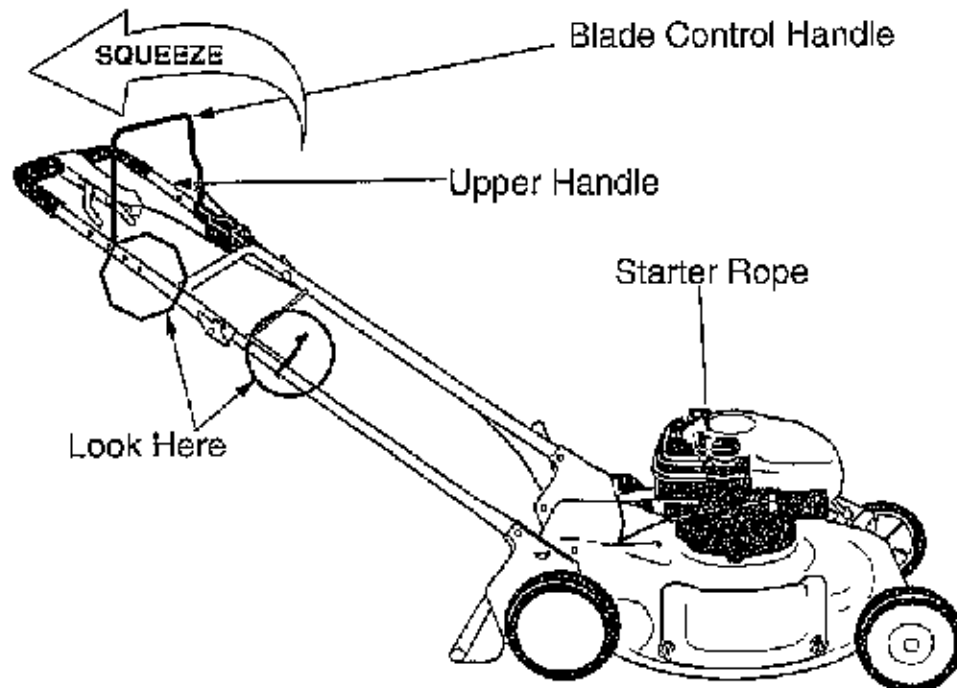

SECTION 7: CONTROLS

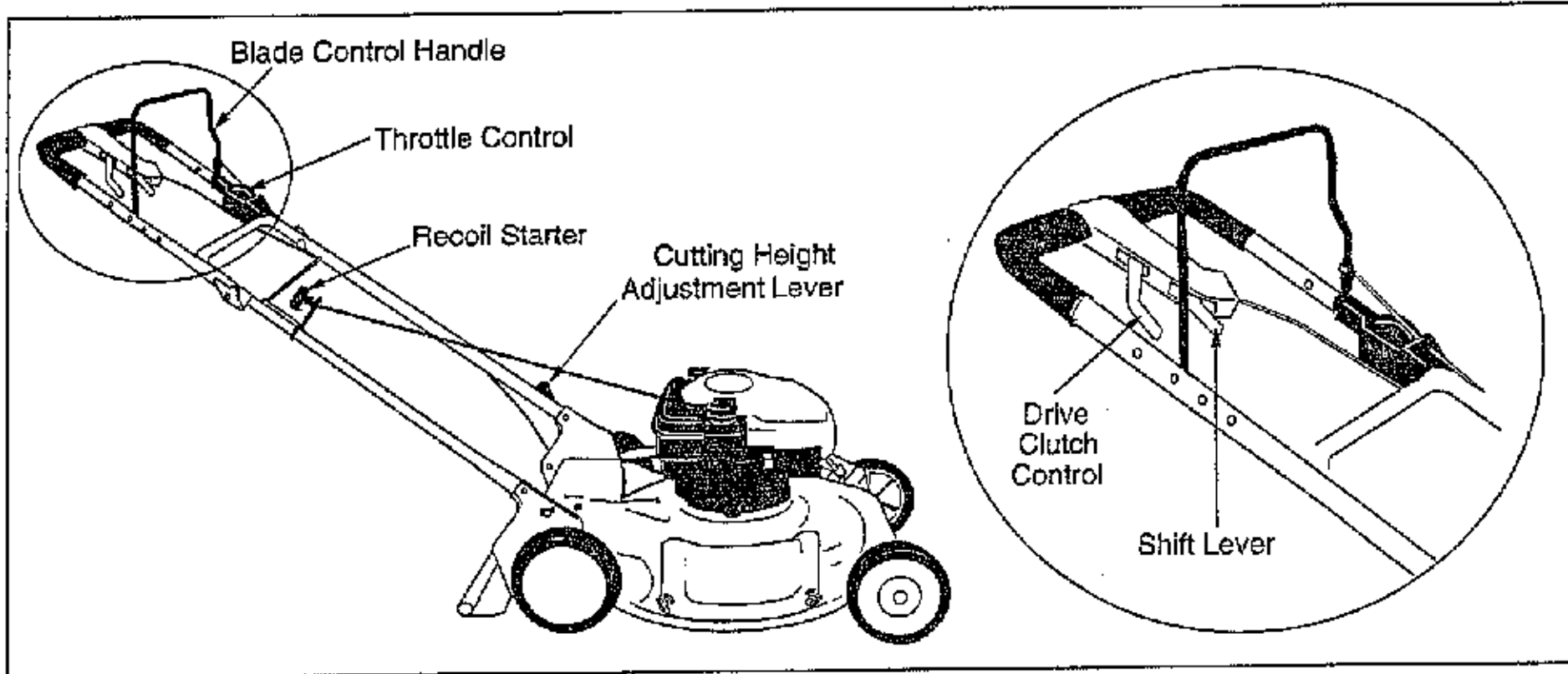

Figure 5

BLADE CONTROL HANDLE

The blade control handle is located on the upper handle of the mower. See Figure 5. The blade control handle must be depressed in order to start and operate the unit. Release the blade control handle to stop the engine and blade.



WARNING: The blade control handle is a safety device. Never attempt to bypass its operations. The blade will be rotating whenever the engine is running.

THROTTLE CONTROL

The throttle control is located on the left side of the upper handle. It is used to regulate the engine speed. See Figure 5.

- Push the throttle lever forward for FAST position.
- Pull the throttle lever back for SLOW position.



WARNING: The throttle control cannot be used to stop the engine.

IGNITION SWITCH (Electric Start Unit Only)

The ignition switch is located on the left side of the handle panel. It is used for starting only. See Figure 6.

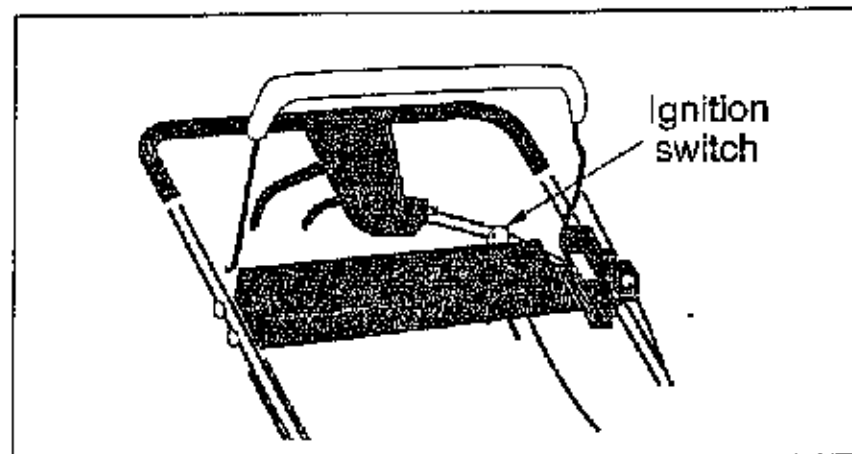

Figure 6 Electric Start Unit Only

RECOIL STARTER

The recoil starter handle is attached to the lower handle. See Figure 5. Stand behind the unit in the operating position to start the unit.

DRIVE CLUTCH CONTROL

Squeeze the drive clutch control to engage the drive system. Release the clutch control to disengage the drive system. Release the clutch control to slow down when negotiating an obstacle, making a turn or stopping.

SHIFT LEVER

The shift lever is located on the drive clutch control housing on the upper handle. See Figure 5. This lever is used to select the forward speed of the mower. When changing speed selection, release the drive clutch control.

NOTE: Move the shift lever only when the engine is running. Changing the shift lever setting with the engine off can cause damage to the mower.

CUTTING HEIGHT ADJUSTMENT LEVER

Note: Your mower is shipped with the cutting height in the lowest position. Adjust the cutting height as follows. The cutting height adjustment lever is located above the left rear wheel. To adjust the cutting height, pull the lever out and away from the mower and then move it forward or backward to select a new cutting height. See Figure 7.

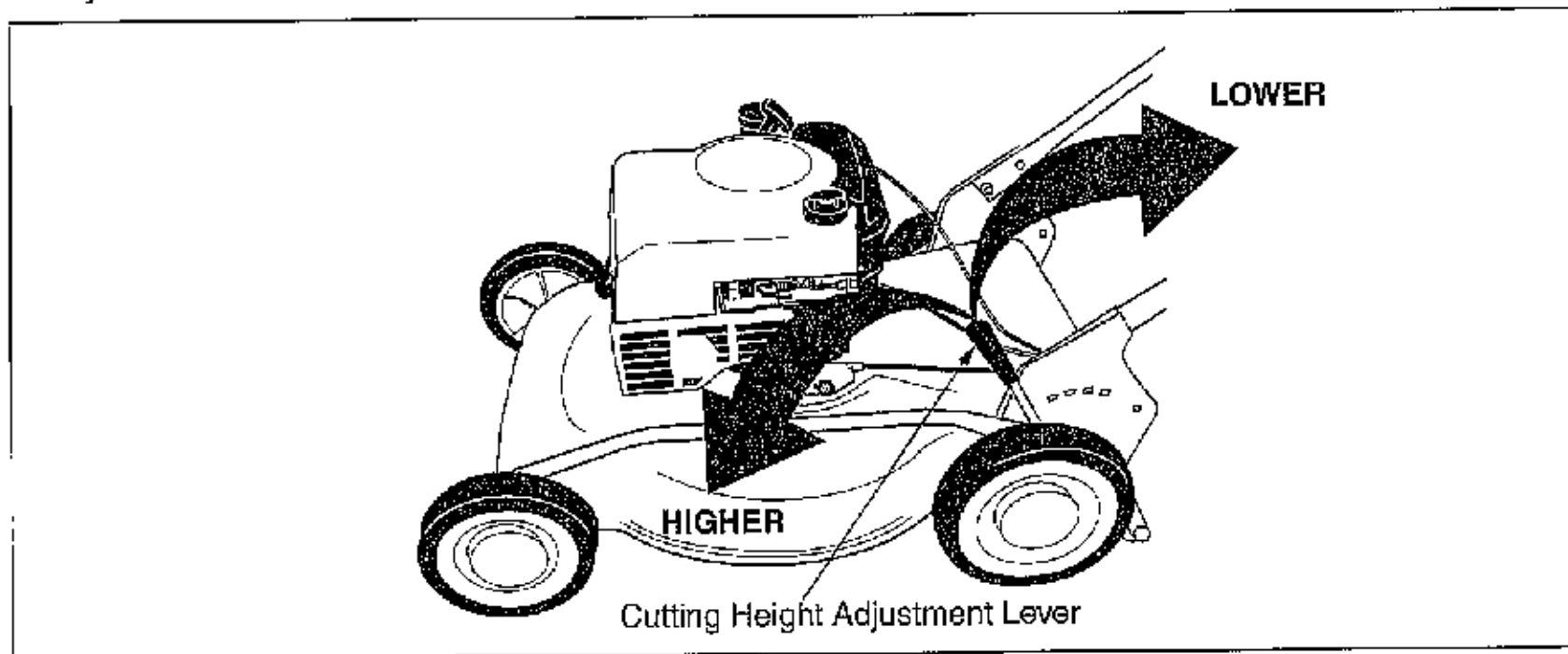

Figure 7

NOTE: For rough or uneven lawns, move the height adjustment lever to a higher position. This will help stop scalping.

ENGINE CONTROLS

See the engine manual for the location and function of the controls located on the engine.

SECTION 8: OPERATION



WARNING: Keep hands and feet away from the chute area on the cutting deck. See Figure 1. The operation of any lawn mower can result in foreign objects being thrown into the eyes, which can result in severe eye damage. Always wear safety glasses or eye shields.

NOTE: For best results raise the cutting position until it is determined which height is best for your lawn. See CUTTING HEIGHT ADJUSTMENT LEVER in the CONTROLS section.

GAS AND OIL FILL-UP

Service the engine with gasoline and oil as instructed in the separate engine manual. Read all instructions carefully.



WARNING: Never fill fuel tank indoors with engine running or until the engine has been allowed to cool for at least two minutes after running.

EACH TIME BEFORE YOU START YOUR MOWER

ELECTRIC START UNITS ONLY:



Warning: The battery contains corrosive fluid and toxic material — HANDLE WITH CARE. Keep away from children. Do not puncture, disassemble, mutilate or incinerate. Explosive gasses could be vented during charging or discharging. Use in a well-ventilated area away from sources of ignition.

Charging Instructions: Charge battery for approximately 16 hours before initial use. However, do not charge longer than 20 hours.

IMPORTANT: Use only the battery charger supplied with this mower.

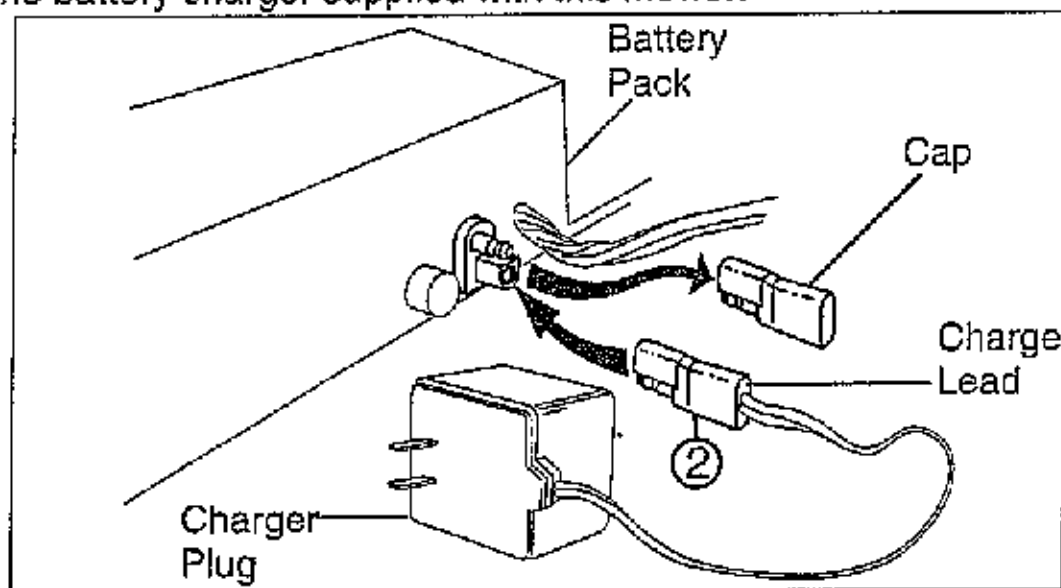

Figure 8

To charge the battery, (1) remove the protective cap from the end of the battery pack lead; (2) plug charge lead into battery pack lead; and (3) insert battery charger plug into 120 volt standard household outlet. See Figure 8. It is very important to follow this order of action for proper charging of the battery.

After charging, disconnect battery charger plug from household outlet first, then disconnect charge lead from battery pack lead.



Warning: Do not remove the battery pack from the handle panel for any reason other than replacement. When replacing the battery pack, refer to the instructions in the maintenance section.

ALL UNITS:

- Attach spark plug wire to spark plug. Make certain the metal cap on the end of the spark plug wire is fastened securely over the metal tip on the spark plug.
- Check for proper drive clutch operation using the NEUTRAL ADJUSTMENT TEST.

NEUTRAL ADJUSTMENT TEST

To perform the NEUTRAL ADJUSTMENT TEST answer the following questions.

- With the drive clutch control released, push mower forward and pull it backward. Does it move freely?
- Squeeze the drive clutch control and pull the mower backward. Do the rear wheels lock (not turn)?
- Is the drive clutch control cable free of kinks or sharp bends?

If you answered “yes” to all three questions, your mower passed the test and you can start your mower. If you answered “no” to any of the three questions, you will have to adjust the drive clutch control following instructions in the DRIVE CLUTCH CONTROL ADJUSTMENT section.

TO START ENGINE AND ENGAGE BLADE

- Move the throttle control lever all the way forward.
- Prime engine as instructed in the separate engine manual.
- Stand behind the unit, squeeze the blade control handle and hold it against the upper handle.
- **Electric Start unit:** Turn the ignition key to the right to start the engine. Release the key after the engine starts.
- **Recoil Start:** Grasp starter handle and pull rope out slowly until engine reaches start of compression cycle (rope will pull slightly harder at this point). Let the rope rewind slowly. Pull rope with a rapid, continuous, full arm stroke. Keep a firm grip on starter handle. Return it slowly to the rope guide.
- After engine starts, move throttle control to desired engine speed. (The mower is designed to be operated at full throttle.)

NOTE: If any problems are encountered, refer to the TROUBLE SHOOTING Section of this manual.

TO STOP ENGINE AND BLADE

- Release the blade control handle to stop the engine and the blade.



WARNING: The blade continues to rotate for a few seconds after the engine is shut off.

USING YOUR ROTARY MOWER

Be sure that the lawn is clear of stones, sticks, wire, or other objects which could damage the lawn mower or the engine. Such objects could be accidentally thrown by the mower in any direction and cause serious personal injury to the operator and others.

For best results, do not cut wet grass because it tends to stick to the underside of the mower, preventing proper discharge of grass clippings, and could cause you to slip and fall. New grass, thick grass or wet grass may require a narrower cut.

For a healthier lawn, never cut off more than one-third of the total length of the grass. Your lawn should be cut in the fall as long as there is growth.

This mower is designed to be operated at full throttle to give you the best cut and do the most effective job of mowing or mulching.



WARNING: If you strike a foreign object, stop the engine. Remove wire from the spark plug, thoroughly inspect the mower for any damage, and repair the damage before restarting and operating the mower. Extensive vibration of the mower during operation is an indication of damage. The unit should be promptly inspected and repaired.

BAGGING GRASS CLIPPINGS (Model 979 Only)

This mower can bag grass clippings. Follow steps 1 through 3 to ready the mower for bagging.

Step 1. Remove wing nuts holding mulching baffle or side discharge chute in place. Then remove plug or discharge chute.

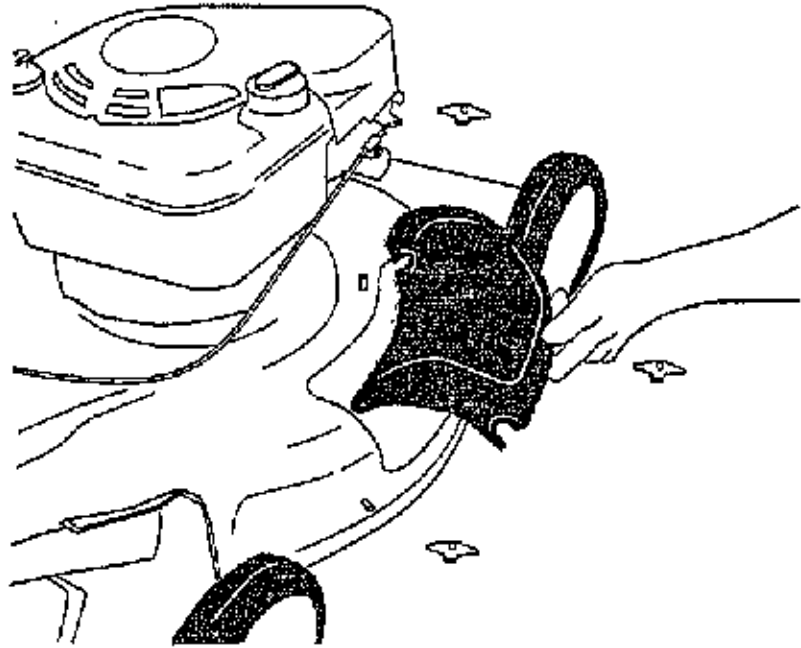

Step 2. Replace with bagging adaptor. Attach using wing nuts. Be sure that inner lip of attachment goes under the edge of the deck.

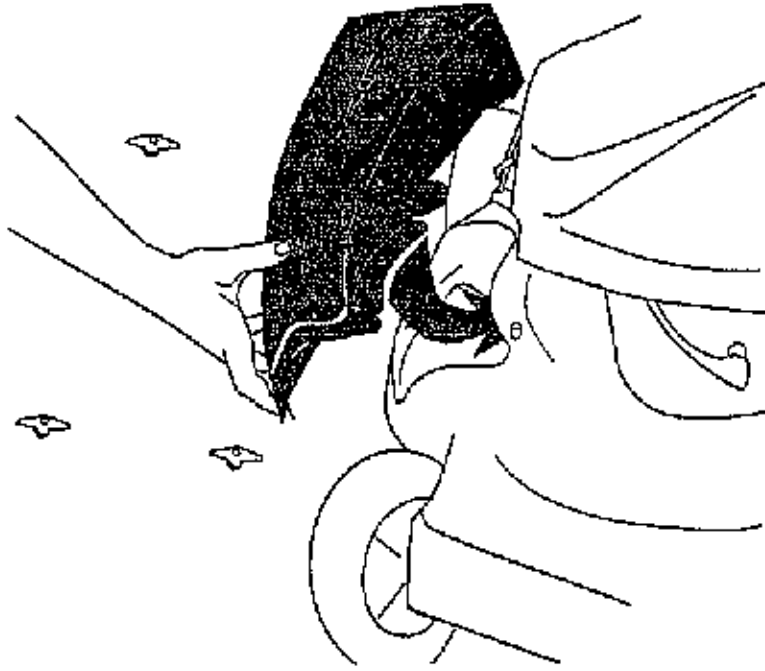

Step 3. Lift chute door and slide bag onto adaptor.

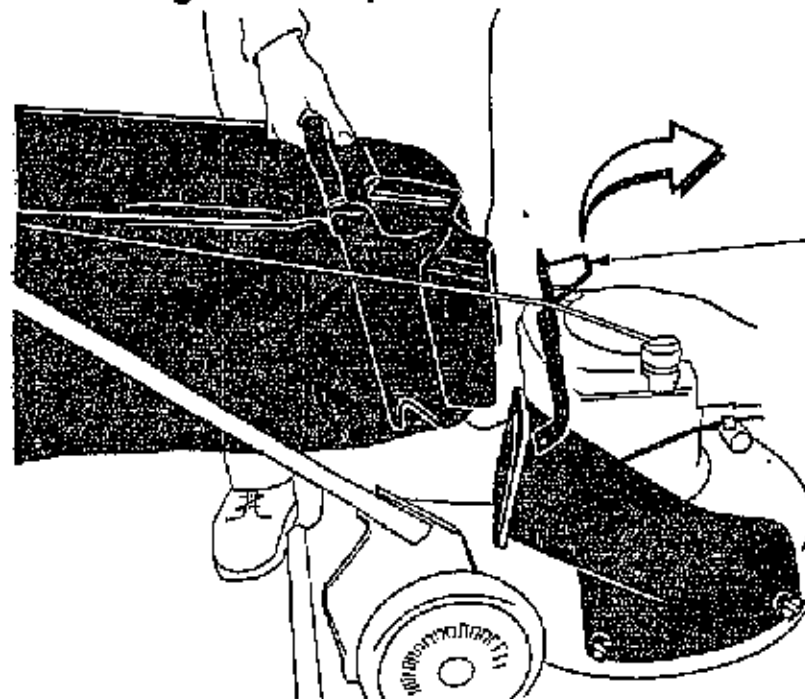

Chute Door

NOTE: The chute door has been designed to move the starter rope out of the way of the bag when the chute door is opened.

Bagging adaptor



Mulching baffle



Side-discharge chute



EMPTYING YOUR GRASS BAG

Holding the grass bag by both the rear handle and the lower handle, lift it straight up. The chute door will move the rope out of the way of the bag. Remove the bag from the bagging adaptor on the mower. While holding the lower handle lift up the rear section of the grass bag as shown in Figure 9. The bag will open and the grass clippings will fall out. See Figure 9. When replacing your grass bag be sure the top of the bag rests on the wire support between the handles.

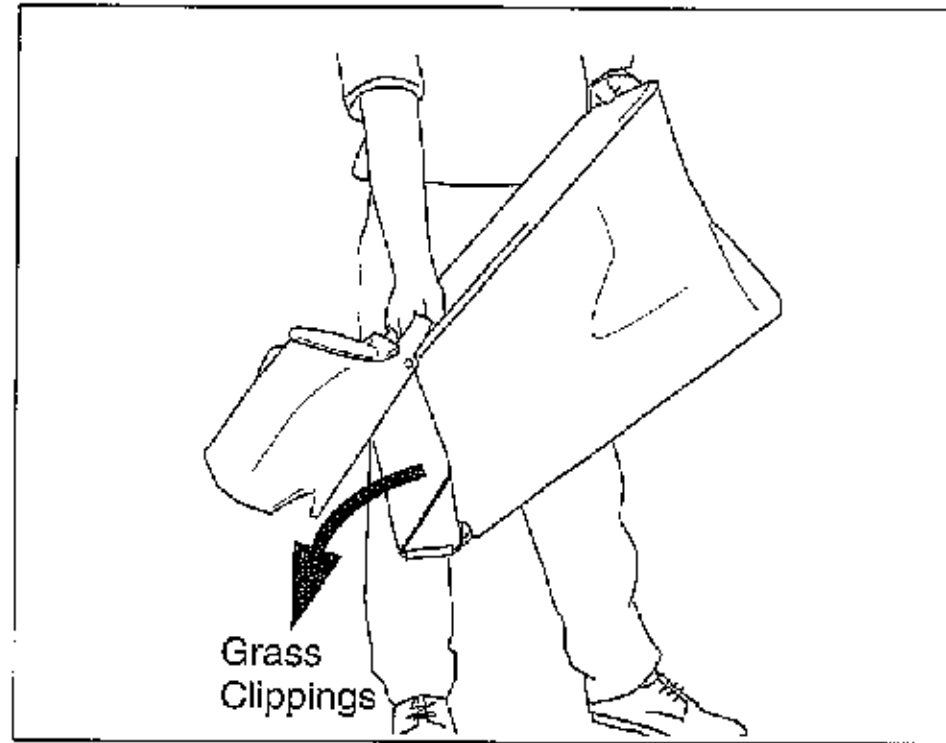
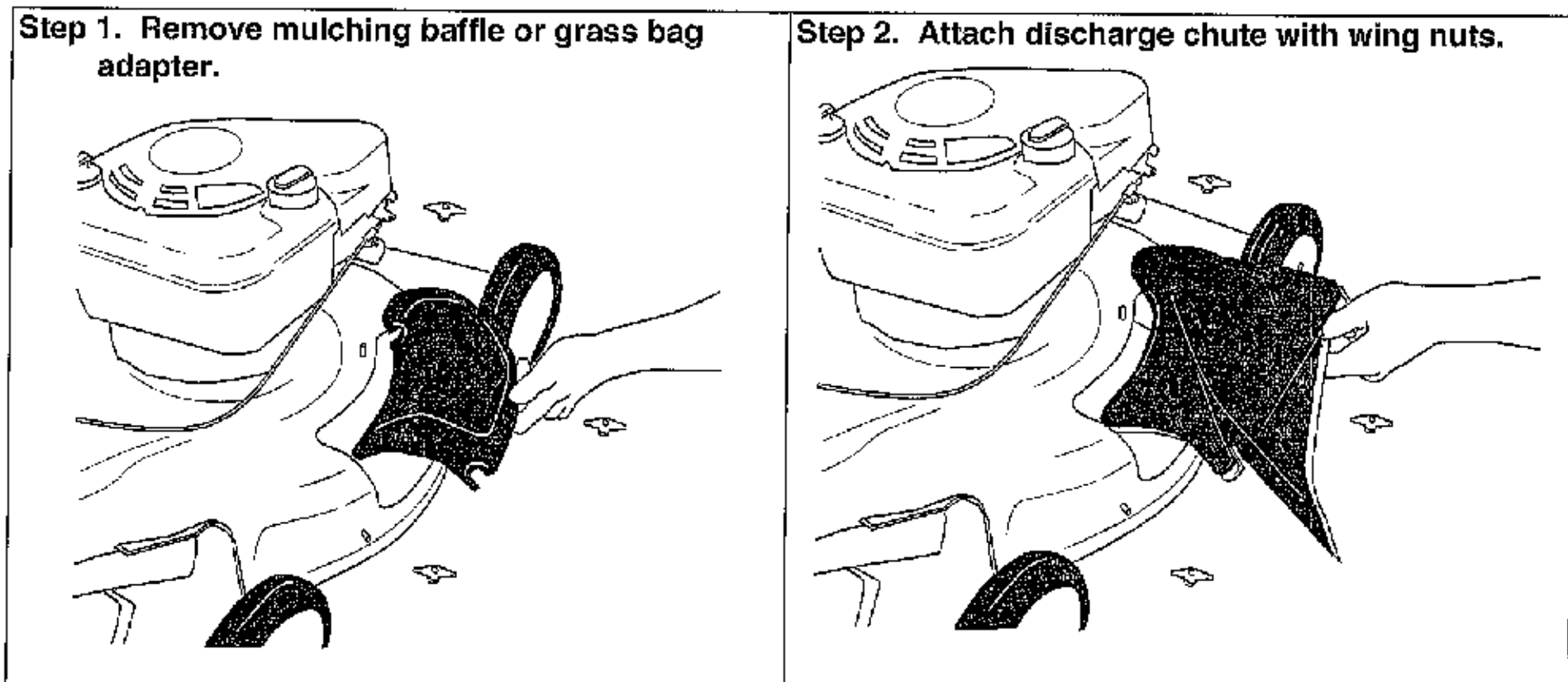

Figure 9

SIDE-DISCHARGE GRASS CLIPPINGS

This mower can also side-discharge grass clippings. Follow steps 1 and 2 to ready this mower for side-discharge operation.



SECTION 9: ADJUSTMENTS



WARNING: Do not at any time make any adjustment to lawn mower without first stopping engine and disconnecting spark plug wire.

HANDLE HEIGHT ADJUSTMENT

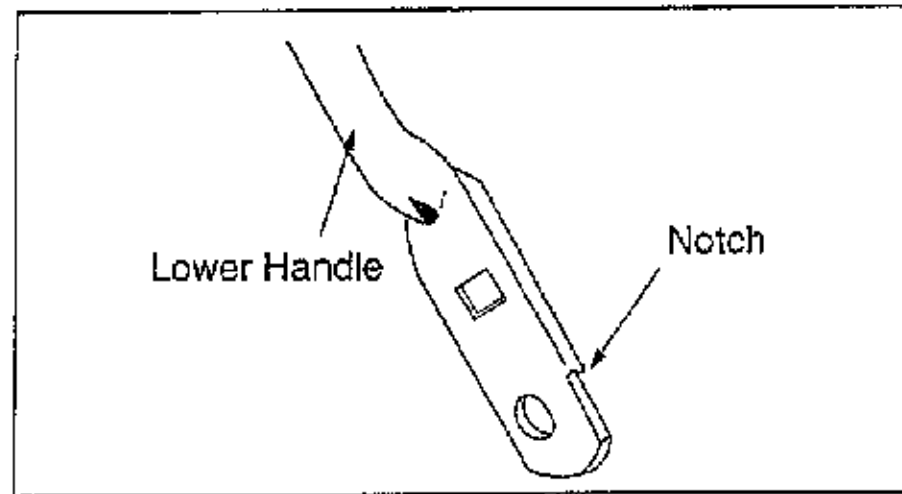

Figure 10

Your mower is shipped with the handle in the higher height position. To lower the height proceed as follows:

- Remove the starter rope from the rope guide.
- Remove the upper handle by removing the hand knobs and carriage bolts. Lay the upper handle out of the way, being careful not to bend or kink the cables.
- Remove the hairpin clips from the weld pins on the handle brackets. Press out on the legs of the lower handle. Remove lower handle from the mower.
- Turn lower handle around so the notch on the bottom of the lower handle is facing forward. See Figure 10. Reassemble, placing the bottom holes in the handle over the weld pins in the handle mounting bracket.
- Reassemble the upper handle to the lower handle.
- Place the hairpin clips in the inner holes in the weld pins and attach the starter rope as instructed in the Set-Up Instructions.

THROTTLE CONTROL ADJUSTMENT

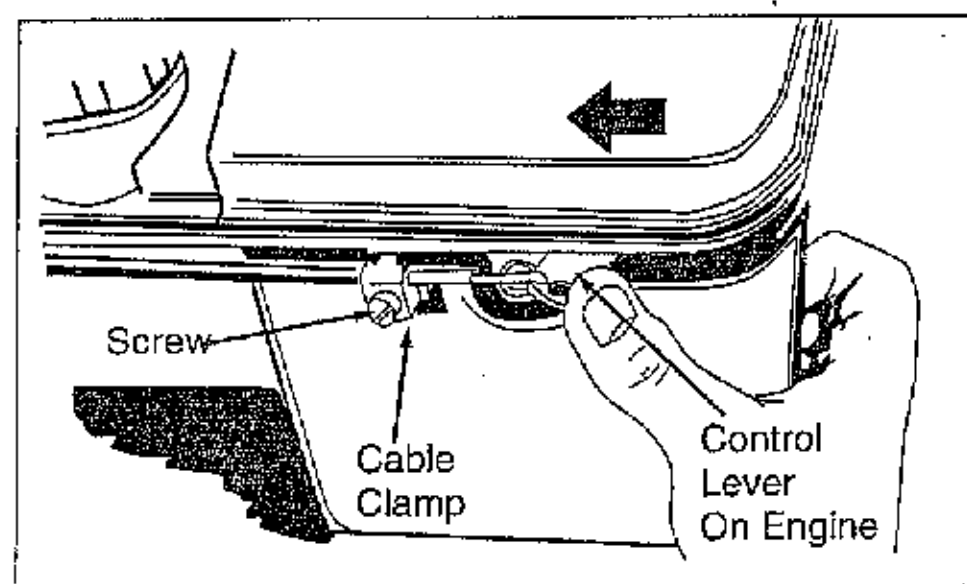

Figure 11

If the throttle control requires adjustment or if it has been replaced, adjust the throttle control as follows.

- Remove the screw shown in Figure 11. Remove the cable clamp from the cable.
- Push the throttle control lever on the handle all the way forward as far as it will go, then back it off one "click". Make certain the throttle control lever remains in this position.
- Push the control lever on the engine as far towards the rear of the engine as it will go. Secure the cable in this position with the cable clamp and the screw.

DRIVE CLUTCH CONTROL ADJUSTMENT

The drive clutch control adjustment wheel is located in the drive clutch control handle housing and is used to tighten or loosen the drive belt. You will have to adjust the drive clutch control if any of the following happens:

- The mower does not propel itself with the drive clutch engaged.
- The mower's drive wheels hesitate with the drive clutch engaged.

To resolve the above problems, rotate the adjustment wheel with your fingers. Clockwise to tighten the cable and counter-clockwise to loosen the cable. See Figure 12.

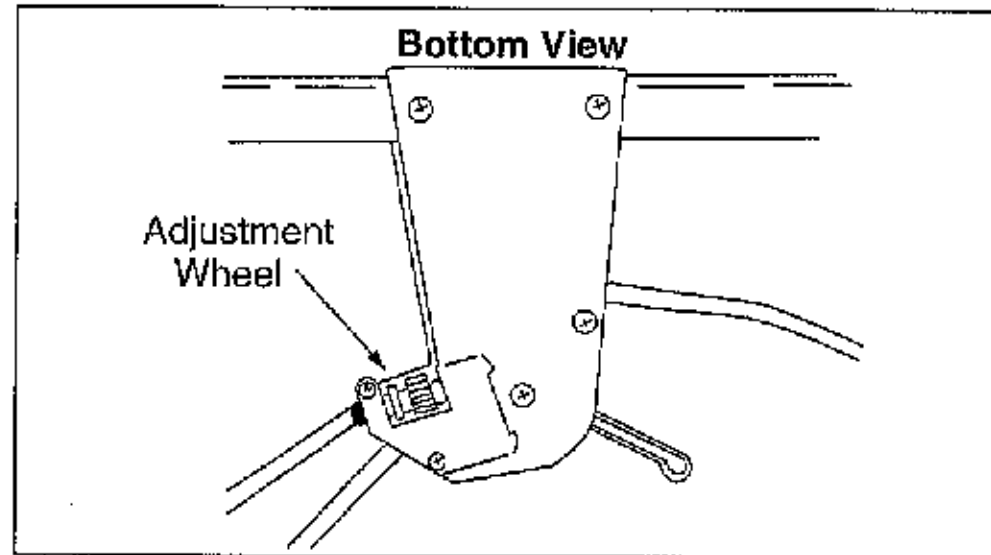

Figure 12

Note: For some people the drive clutch handle may not be in a comfortable position. You can adjust the handle out by tightening the adjustment wheel.

SHIFT LEVER CABLE ADJUSTMENT

Periodic adjustment of the six speed shift cable may be required due to normal wear on the cable. Adjustment is needed if all six speeds do not work.

The adjustable cable bracket is located on the left side of the mower, beside the engine. Follow steps 1 through 7 to adjust the shift lever.

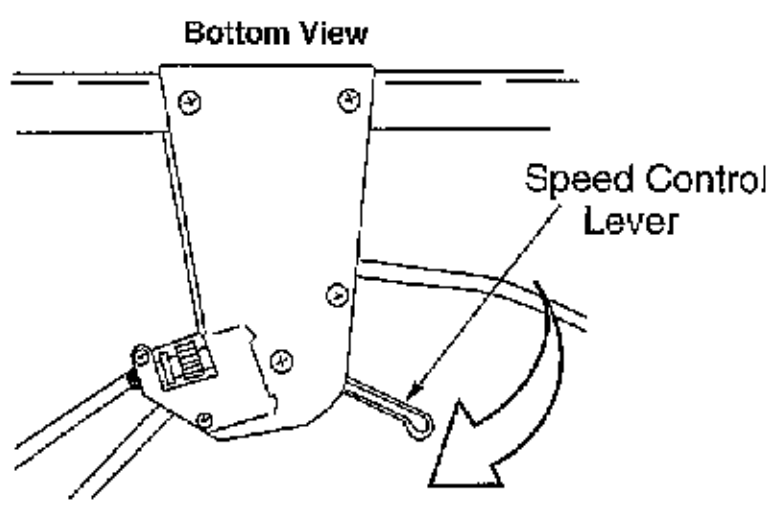
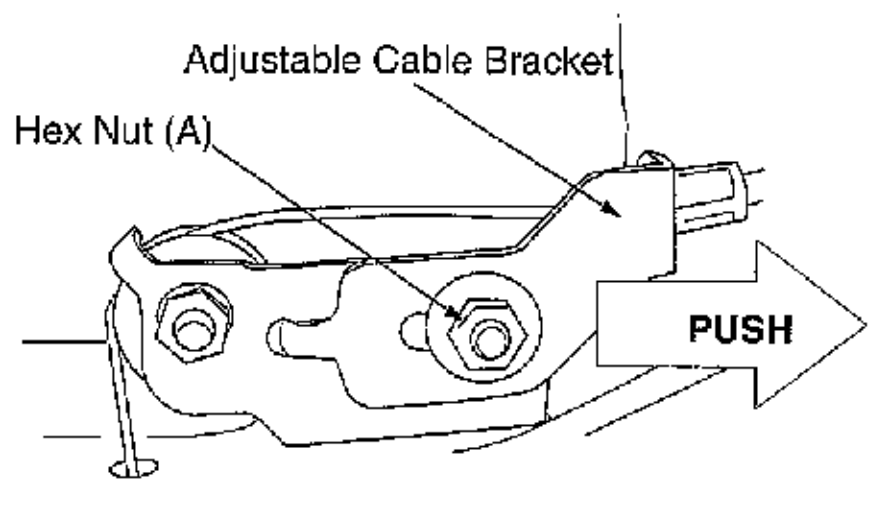
	
<p>Step 1. Start engine.</p> <p>Step 2. Place speed control in the sixth speed position.</p> <p>Step 3. Stop engine.</p> <p>Step 4. Disconnect spark plug wire and ground it.</p>	<p>Step 5. Loosen hex nut (A) which secures the adjustable cable bracket.</p> <p>Step 6. Push back on the adjustable cable bracket.</p> <p>Step 7. Tighten hex nut (A).</p>

SECTION 10: MAINTENANCE



WARNING: Be sure to disconnect and ground the spark plug wire before performing any repairs or maintenance.

NOTE: When tipping the unit, empty the fuel tank and keep the engine spark plug side up. Never tip the mower more than 90 degrees and do not leave the mower tipped for any length of time. Oil can drain into the upper part of the engine causing a starting problem.

ENGINE

Refer to the separate engine manual for all engine maintenance instructions.

- Maintain engine oil as instructed in the separate engine manual packed with your unit. Read and follow instructions carefully.
- Service air cleaner every 25 hours under normal conditions. Clean every few hours under extremely dusty conditions. Poor engine performance and flooding usually indicate that the air cleaner should be serviced. To service the air cleaner, refer to the separate engine manual packed with your unit.
- The spark plug should be cleaned and the gap reset once a season. Spark plug replacement is recommended at the start of each mowing season; check engine manual for correct plug type and gap specifications.
- Clean the engine regularly with a cloth or brush. Keep the cooling system (blower housing area) clean to permit proper air circulation which is essential to engine performance and life. Be certain to remove all grass, dirt and combustible debris from muffler area.

DECK

The underside of the mower deck should be cleaned after each use to prevent a buildup of grass clippings, leaves, dirt or other matter. If this debris is allowed to accumulate, it will invite rust and corrosion, and may prevent proper mulching, discharge or bagging.

The deck may be cleaned by tilting the mower and scraping clean with a suitable tool (make certain the spark plug wire is disconnected).

ELECTRIC START UNITS ONLY:

BATTERY PACK REPLACEMENT

Remove the battery pack from the handle panel for replacement only. Do not separate the batteries for any reason. Dispose of batteries properly.



WARNING: Batteries contain sulfuric acid which may cause burns. Do not short circuit or mutilate in any way. Do not put batteries in fire. They may burst or release toxic materials.

When replacing battery pack in handle panel, battery pack must be positioned with the positive terminal to the right hand side and the negative terminal to the left hand side of panel. Replacing the battery pack incorrectly will cause serious damage.

The positive lead on the wire harness has the smaller connector. Connect the positive lead to the positive side of the battery pack, then connect the negative side.

IN-LINE FUSE

The unit is equipped with an in-line fuse. If unit fails to start, check the fuse inside the battery cover by turning the end of the fuse holder and removing from the battery cover. Replace with standard automotive 7-1/2 amp fuse.

STORAGE OF THE BATTERY

The battery must be stored with a full charge. A discharged battery will freeze.

IMPORTANT: All batteries discharge during storage. Recharge battery every two months and before returning to service. Refer to charging instructions in OPERATION section.