

# WS4916 Series Wireless Smoke Detector

## Installation and Operating Instructions

Read this instruction sheet thoroughly before installation and use of the WS4916 Wireless Smoke Detector

### Introduction

The WS4916 is a wireless photoelectric smoke detector with a fixed temperature heat detector and an internal piezoelectric alarm. Three versions are available: US version (UL), Canadian version (ULC) and an International version (EU).

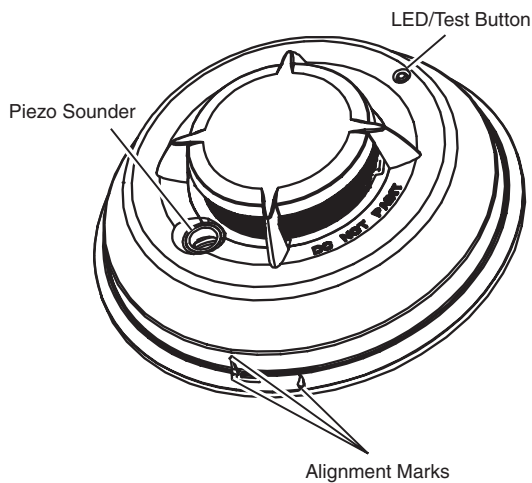

### Operation

Approximately every 7 to 8 seconds the unit tests for a smoke or heat alarm condition. During this sequence the unit also performs self diagnostics, and checks for tampers and faults. During normal operation the LED will flash every 50 seconds and the sounder will not sound.

### Smoke Alarm

The smoke detector will go into alarm when the signal level exceeds the 'alarm' threshold and automatically restore when the signal level falls below the alarm 'restore' threshold. During an alarm the LED will flash 1/second and the sounder will sound the evacuation temporal pattern (UL, EU) or continuous beeps (ULC).

The smoke detector has a preset warning threshold at 75% of the alarm threshold. If the signal level stays above this threshold, but below the alarm threshold, for more than 120 seconds, the detector will go into the 'warning' state. If the signal level falls below the early warning 'restore' threshold, the detector will restore to its normal state automatically. If the signal level rises above the alarm threshold, the detector will go into alarm. The LED will flash and the sounder will chirp every 50 seconds when in the warning state.

**NOTE:** This feature is intended to provide a warning if the environment is persistently close to the alarm threshold and provide more time to investigate and either escape or correct the situation.

### Smoke - Drift Compensation

The detector automatically compensates for long-term environmentally induced changes to maintain a constant smoke sensitivity. When the drift compensation has reached its high or low limit of adjustment, the detector will go into the trouble state.

### Heat Alarm

The heat detector will go into alarm when the heat signal level exceeds the heat alarm threshold (135°F/57°C); and will automatically restore when the heat signal level falls below the heat alarm threshold (restore). During an alarm the LED will flash 1/second and the sounder will sound the evacuation temporal pattern (UL, EU) or continuous beeps (ULC).

### Tamper

The removal of the detector from the mounting plate initiates a 'tamper' transmission. The tamper condition is restored after the detector is mounted on the plate.

### Wireless Transmissions

A supervisory message is transmitted at 64 minute intervals (12 minutes in EU model) to the control panel. If the signal is not received the control panel determines that the detector is missing. The detector transmits the following:

- **Alarm / Alarm Restore** - (heat or smoke alarm). Transmitted at time of occurrence.
- **Tamper / Tamper Restore** - (tamper switch activated) 10 second maximum delay on restore before transmission.
- **Low Battery** - (battery voltage falls below threshold). The batteries are tested & transmitted at the time of a supervisory or other transmissions.
- **Trouble** - (detector fault or sensor compensation limit reached). Troubles are transmitted at the time of occurrence (one trouble per supervisory interval).

### Batteries

The WS4916 is powered by two, 3Vdc lithium batteries.

**Do NOT use batteries other than those listed.**

The low battery threshold is set so the batteries will provide not less than 14 days of operation and at that point the detector will send a 'low battery' signal. If the battery is still low 7 days after falling through the low battery threshold, the horn will 'chirp' once every 48 seconds until battery failure. During the first 7 days after low battery detection, (non-chirp period), if the detector is tested or goes into alarm, the horn will 'chirp' once the test or alarm is restored and remain 'chirping' until battery failure.

## Installation Instructions

### Installation

The WS4916 Series wireless Smoke detector shall be installed and used within an environment that provides the pollution degree max 2 and overvoltages category II in NON HAZARDOUS LOCATIONS, indoor only. The equipment is designed to be installed by SERVICE PERSONS only; [SERVICE PERSON is defined as a person having the appropriate technical training and experience necessary to be aware of hazards to which that person may be exposed in performing a task and of measures to minimize the risks to that person or other persons.]

#### 1. Smoke Detector Placement

On smooth ceilings, detectors may be spaced 9.1m (30 feet) apart as a guide. Other spacing may be required depending on ceiling height, air movement, the presence of joists, uninsulated ceilings, etc. Consult National Fire Alarm Code NFPA 72 Chapter 11, CAN/ULC-S553-02 or other appropriate national standards for installation recommendations.

- Do **NOT** locate smoke detectors at the top of peaked or gabled ceilings; the dead air space in these locations may prevent the unit from detecting smoke. Avoid areas with turbulent air flow, such as near doors, fans or windows. Rapid air movement around the detector may prevent smoke from entering the unit.
- Do **NOT** locate detectors in areas of high humidity.
- Do **NOT** locate detectors in areas where the temperature rises above 38°C (100°F) or falls below 5°C (41°F).

Install Smoke detectors in accordance with NFPA 72, Chapter 11.

*"Smoke detectors shall be installed outside of each sleeping area in the immediate vicinity of the bedrooms and on each additional story of the family living unit, including basements and excluding crawl spaces and unfinished attics. In new construction, a smoke detector also shall be installed in each sleeping room."*

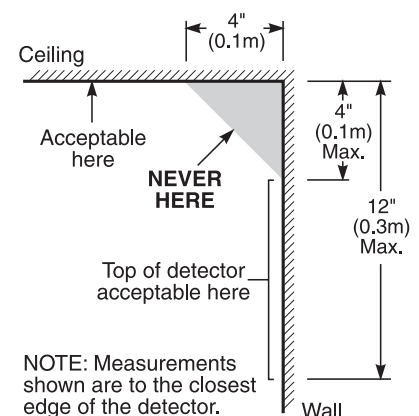

29034617R008

## 2. Mount Smoke Detector Backplate

Secure backplate to the mounting surface using the screws provided.

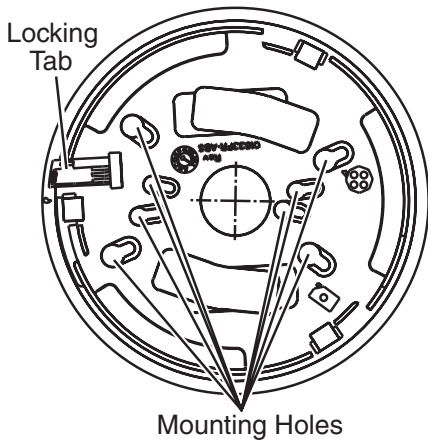

**CAUTION:** The dust cover protects the unit when not in service. Remove the dust cover before use.

## 3. Install Batteries

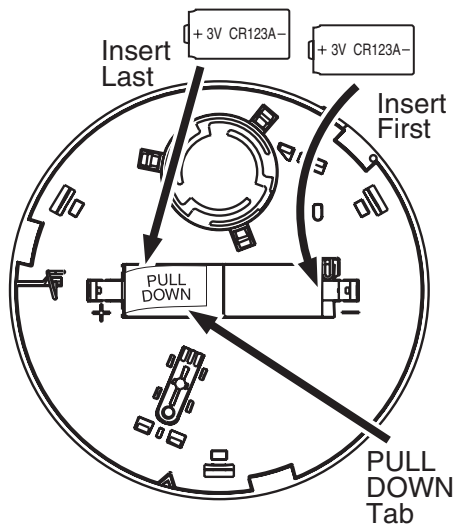

If batteries are not installed, install batteries in the sequence indicated. Use only approved Panasonic CR123A, Sanyo CR123A or Duracell DL123A batteries. If batteries are installed, remove the 'Pull' tab to activate.

**CAUTION:** Without batteries the unit cannot be mounted onto the base plate properly! (WS4916AUS version only).

## 4. Mounting

• **Detector Installation:** Position the detector on to the base plate using the detector and base plate alignment marks. Press the detector gently in place while rotating the detector clockwise until the detector snaps into place. Remove the side tab from the locking tab to lock in place (optional).

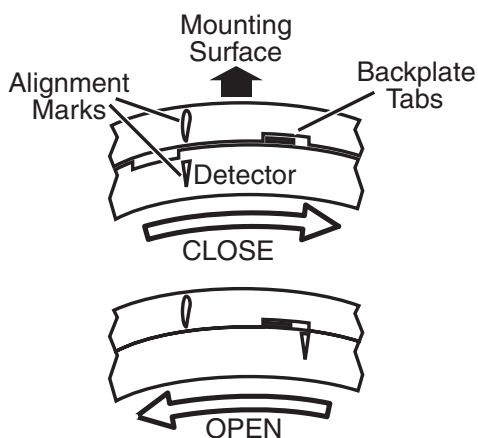

• **Removal:** Depress tab with a small slotted screwdriver. Rotate detector counter-clockwise until the alignment marks line up. Remove detector.

## Installer Compensation Reset

Cleaning or replacement of the smoke sensor chamber changes the background signal/noise of the detector; this requires the drift compensation be reset. Compensation trouble is one of the faults indicated when the LED indicator is OFF while the sounder is chirping.

1. Remove batteries, then short the detector battery contacts for 5 seconds to power down unit.
  2. Replace batteries to power up unit while pressing the test button.
  3. The tamper switch must not be pressed.
  4. The LED will flash when 5 seconds has elapsed. Release the test button within 2 seconds of the LED flash.
  5. The LED will flash every 2 seconds for 1 minute. During this period, the detector must be mounted.
- Allow an additional 2 minutes for the detector to make background level checks.**
6. Test the detector to verify normal operation.

## 5. Test Unit

**NOTE:** The central monitoring station (if used) should be notified prior to the test being generated. This will prevent a false alarm and an unnecessary response from the central monitoring station.

Initiate test by pressing the test button for 5 seconds minimum. Alarm activation is indicated by the flashing LED, the sounder, and transmission of the alarm signal to the control panel. The detector restores to normal when the test button is released.

**NOTE:** Allow a minimum of 20 seconds after power up and, after test, alarm or tamper restore activations. Do not use test button when smoke is present.

**NOTE:** If the detector is in one of the following states when a test is initiated; it will not enter an alarm state.

- Tamper, (detector not installed on mounting plate)
- Compensation Trouble
- Other internal faults that could prevent a smoke or heat alarm.

**NOTE:** Smoke sensitivity of installed detectors can be measured without removal or an alarm being generated using the FSD-100 Smoke Detector Test Meter.

To test the unit using the FSD-100, set the test meter up to read devices as per the instructions supplied. Depress the test button on the smoke detector for 1 second and release.

**NOTE:** If the test button is held for 5 seconds or longer, an alarm will be generated.

Move the test meter over the center of the detector, wait until you hear the test meter beep, remove the unit and the information can be immediately reviewed. Please see the instructions supplied with the FSD-100 Smoke Detector Test Meter for more information.

## 6. Device Enrollment

The 6 digit serial number located on the back of the smoke detector housing must be enrolled into the alarm control panel with Installer programming. Refer to the receiver **Installation Manual** for details. For placement tests remove detector from backplate for one second (tamper) then reattach. Wait at least 30 seconds for test result before activating again.

## Owners Instructions

### Fire Safety In The Home

Most fires occur in the home, and to minimize this danger, it is recommended that a household fire safety audit be conducted and a family escape plan be developed.

### Household Fire Safety Audit

1. Are all electrical appliances and outlets in safe condition? Check for frayed cords, overloaded lighting circuits, etc. If you are uncertain about the condition of your electrical appliances or household service, have a professional evaluation.
2. Are all flammable liquids safely stored in closed containers, and in a cool and well ventilated area? Cleaning the unit with flammable liquids should be avoided.
3. Are hazardous materials (i.e. matches) out of the reach of children?
4. Are furnaces and wood burning appliances properly installed, clean, and in good working order? If in doubt, have a professional evaluation.

## Family Escape Planning

There is often very little time between the detection of a fire and the time it becomes deadly. Because of this, it is very important that a family escape plan be developed and rehearsed.

- Every family member should participate in the escape plan.
- Study the possible escape routes from each location within the house. Since many fires occur at night, special attention should be given to the escape routes from sleeping quarters.
- It is essential that escape from a bedroom be possible without opening the interior door. Consider the following when making your escape plans:
  - Ensure that doors and windows that open to the outside are easily opened. Ensure that they are not painted shut and that the locking mechanisms operate smoothly.
  - If opening or using the exit is too difficult for children, the elderly or handicapped, plans for their rescue should be developed. This plan includes making sure that those who are to perform the rescue can promptly hear the fire warning signal.
  - If the exit is above the ground level, an approved fire ladder or rope should be provided, as well as training in its use.
- Exits on the ground level should be kept clear. Be sure to remove snow from exterior patio doors in the winter and that outdoor furniture or equipment does not block exits.
- The family should have a predetermined assembly point where everyone can be accounted for; for example, across the street or at a neighbor's house.
- Once everyone is out of the house, call the Fire Department.
- A good plan emphasizes a quick escape. Do not investigate first or attempt to fight the fire, and do not attempt to rescue belongings or valuables as this takes up time. Once outside, do not re-enter the house; wait for the Fire Department.
- Write the plan down and rehearse it frequently so that should an emergency ever arise, everyone will know what to do. Revise the plan as conditions change; for example, when there are more or fewer family members in the home or if there are changes to the house.
- Make sure your fire warning system is operational by conducting weekly tests. If you are unsure about system operation, contact your smoke detector installer or dealer.
- DSC recommends that you contact your local Fire Department and request further information on home fire safety and escape planning. If available, have your local fire prevention officer conduct an in-house fire safety inspection.

## Testing Your Smoke Detector

**Follow the test procedure described here or contact your smoke detector dealer or installer for testing instructions. DSC recommends that you test the entire alarm system at least once a week to verify the operation of all system functions.**

### Smoke Detector Unit Test

Initiate test by pressing the test button for 5 seconds (min.), the sounder makes clicking noises during this time. Press the button until the unit alarm sounds, an alarm should be sent to the control panel. When the button is released, the alarm should cease. If this does not occur, ensure batteries are the correct type, in good condition and are installed correctly (see **3. Install Batteries** in the **Installation Instructions** section).

Upon completing the functional testing of the smoke detector, check the unit's sensing chamber to ensure proper operation. To test the sensing chamber, wave a lit cotton wick or punk stick around the outside of the unit until a generous amount of smoke enters the sensing chamber or the unit alarms. If the smoke detector does not function properly, call your smoke detector installer or dealer for service.

## Owners Maintenance

The smoke detector is designed to require minimum maintenance. If the case becomes dusty, vacuum with a small brush attachment. If the case is greasy, wipe the case gently with a soft cloth slightly dampened with soapy water.

**Never disassemble the smoke detector; there are no user serviceable parts inside the unit. You may only remove detector from backplate to replace batteries if not serviced by installer. When replacing the batteries, follow the instructions specified within the Installation Instructions, Item 3 Install Batteries.**

**CAUTION: This product uses lithium batteries, improper handling may result in a HEAT, EXPLOSION or FIRE causing personal injury. DO NOT recharge batteries. Follow the battery manufacturer's safety instructions. Dispose of used batteries in accordance with the regulations in your area.**

**Never paint the unit. Paint may prevent smoke from entering the unit. If you are planning renovations or repainting, contact your installer and ask that the unit be temporarily removed until work is complete.**

If the unit is located in an area where it is exposed to high levels of dust or insects and causes false alarms, it may require service; contact your smoke detector installer or dealer.

Testing and maintenance procedures shall be in accordance with CAN/ULC-S552-02.

## Specifications

- Diameter (base): 5.8in (147mm)
- Height (including base): 2.077in (528mm)
- Alarm Sensitivity (threshold) UL: 3.0±0.8%/ft obscuration, ULC: 2.0±0.5 %/ft obscuration
- Alarm Sensitivity (threshold) EU: complies with EN54-7
- Warning threshold: 75% of alarm threshold for 120 seconds
- Heat Alarm: 135°F (57°C)
- Supervisory Transmission Frequency UL, ULC: 64 min. intervals
- Supervisory Transmission Frequency EU: 12 minute intervals
- Sounder Alarm Pattern UL, EU: evacuation temporal pattern
- Sounder Alarm Pattern ULC: continuous beeps
- Operating Temperature: 32°-100°F (0°-37.8°C)
- Humidity: 5%-95% RH, non-condensing
- Batteries (2) CR123A
- Low Battery Detection Low battery 14 days remaining
- Approved Batteries: Panasonic CR123A, Sanyo CR123A and Duracell DL123A

## Alarm Indications

Condition	LED	Sounder	Transmission
Normal	Flash 1/50s	OFF	Supervisory
Alarm Smoke	Flash 1/1s	Temporal or Steady	Alarm
Alarm Heat	Flash 1/1s	Temporal or Steady	Alarm
Early Warning Smoke	Flash 1/50s	CHIRP	None
Compensation Trouble High	OFF	CHIRP	Trouble
Compensation Trouble Low	OFF	CHIRP	Trouble
Sensor/Internal Fault	OFF	CHIRP	Trouble
Low Battery 0 - 7 days	Flash 1/50s	OFF	Low Battery
Low Battery 0 - 7 days & Test or Alarm	Flash 1/50s	CHIRP	Low Battery
Low Battery After 7 days	Flash 1/50s	CHIRP	Low Battery
Tamper	Flash 1/50s	OFF	Tamper

*This product has been approved by the California State of Fire Marshal (CSFM) pursuant to section 13144.1 of the California Health and Safety Code. See CSFM Listing No. 7272-1273:125 for allowable values and/or conditions for use concerning material presented in this document. The approval is subject to re-examination, revision and possible cancellation.*

*This manual shall be used in conjunction with the Installation Manual of the alarm control panel. All the instructions specified within that manual must be observed.*

## Limited Warranty

Digital Security Controls warrants that for a period of twelve months from the date of purchase, the product shall be free of defects in materials and workmanship under normal use and that in fulfillment of any breach of such warranty, Digital Security Controls shall, at its option, repair or replace the defective equipment upon return of the equipment to its repair depot. This warranty applies only to defects in parts and workmanship and not to damage incurred in shipping or handling, or damage due to causes beyond the control of Digital Security Controls such as lightning, excessive voltage, mechanical shock, water damage, or damage arising out of abuse, alteration or improper application of the equipment.

The foregoing warranty shall apply only to the original buyer, and is and shall be in lieu of any and all other warranties, whether expressed or implied and of all other obligations or liabilities on the part of Digital Security Controls. Digital Security Controls neither assumes responsibility nor authorizes any other person purporting to act on its behalf to modify or to change this warranty, nor to assume for it any other warranty or liability concerning this product.

In no event shall Digital Security Controls be liable for any direct, indirect or consequential damages, loss of anticipated profits, loss of time or any other losses incurred by the buyer in connection with the purchase, installation or operation or failure of this product.

**Smoke Detectors:** Smoke detectors that are a part of this system may not properly alert occupants of a fire for a number of reasons, some of which follow. The smoke detectors may have been improperly installed or positioned. Smoke may not be able to reach the smoke detectors, such as when the fire is in a chimney, walls or roofs, or on the other side of closed doors. Smoke detectors may not detect smoke from fires on another level of the residence or building.

Every fire is different in the amount of smoke produced and the rate of burning. Smoke detectors cannot sense all types of fires equally well. Smoke detectors may not provide timely warning of fires caused by carelessness or safety hazards such as smoking in bed, violent explosions, escaping gas, improper storage of flammable materials, overloaded electrical circuits, children playing with matches or arson.

Even if the smoke detector operates as intended, there may be circumstances when there is insufficient warning to allow all occupants to escape in time to avoid injury or death.

*Warning: Digital Security Controls recommends that the entire system be completely tested on a regular basis. However, despite frequent testing, and due to, but not limited to, criminal tampering or electrical disruption, it is possible for this product to fail to perform as expected.*

*Important Information: Changes or modifications not expressly approved by Digital Security Controls could void the user's authority to operate this equipment.*

### FCC Compliance Statement

*CAUTION: Changes or modifications not expressly approved by DSC could void your authority to use this equipment.*

This equipment generates and uses radio frequency energy and if not installed and used properly, in strict accordance with the manufacturer's instructions, may cause interference to radio and television reception. It has been type tested and found to comply with the limits for Class B device in accordance with the specifications in Subpart "B" of Part 15 of FCC Rules, which are designed to provide reasonable protection against such interference in any residential installation. However, there is no guarantee that interference will not occur in a particular installation. If this equipment does cause interference to television or radio reception, which can be determined by turning the equipment off and on, the user is encouraged to try to correct the interference by one or more of the following measures:

- Re-orient the receiving antenna
- Relocate the alarm control with respect to the receiver
- Move the alarm control away from the receiver
- Connect the alarm control into a different outlet so that alarm control and receiver are on different circuits.

If necessary, the user should consult the dealer or an experienced radio/television technician for additional suggestions. The user may find the following booklet prepared by the FCC helpful: "How to Identify and Resolve Radio/Television Interference Problems". This booklet is available from the U.S. Government Printing Office, Washington, D.C. 20402, Stock # 004-000-00345-4.

Industry Canada Compliance Statement: This Class B digital apparatus meets all requirements of the Canadian interference-causing equipment regulations.

Cet appareil numérique de la Classe B respecte toutes les exigences de règlement sur le matériel brouilleur du Canada.

The term "IC:" before the radio certification number only signifies that Industry Canada technical specifications were met.

**This Manual covers the following models:**

**WS4916, WS4916NA, WS4916CE**

DSC erklærer herved at denne komponenten overholder alle viktige krav samt andre bestemmelser gitt i direktiv 1999/5/EC.

Por este meio, a DSC, declara que este equipamento está em conformidade com os requisitos essenciais e outras determinações relevantes da Directiva 1999/5/EC.

"DSC bekräftar härmed att denna apparat uppfyller de väsentliga kraven och andra relevanta bestämmelser i Direktivet 1999/5/EC".

Con la presente la Digital Security Controls dichiara che questo prodotto è conforme ai requisiti essenziali ed altre disposizioni rilevanti relative alla Direttiva 1999/05/CE.

Por la presente, DSC declara que este equipo está en conformidad con los requisitos esenciales y otros requisitos relevantes de la Directiva 1999/5/EC.

Hierdurch erklärt DSC, daß dieses Gerät den erforderlichen Bedingungen und Voraussetzungen der Richtlinie 1999/5/EC entspricht.

'Δία του παρόντος, η DSC, δηλώνει ότι αυτή η συσκευή είναι σύμφωνη με τις ουσιαστικές απαιτήσεις και με όλες τις άλλες σχετικές αναφορές της Οδηγίας 1999/5/EC'.

Hierbij verklaart DSC dat dit toestel in overeenstemming is met de eisen en bepalingen van richtlijn 1999/5/EC.

Par la présente, DSC déclare que cet article est conforme aux exigences essentielles et autres pertinentes stipulations de la directive 1999/5/EC.

DSC vakuuttaa laitteen täyttävän direktiivin 1999/5/EC olennaiset vaatimukset.

Hereby, DSC, declares that this device is in compliance with the essential requirements and other relevant provisions of Directive 1999/5/EC.

**The complete R & TTE Declaration of Conformity can be found at [www.dsc.com/intl/rttedirect.htm](http://www.dsc.com/intl/rttedirect.htm).**



1175  
DSC, Toronto, Canada  
2006  
1175-CPD-001

EN54-5 (2000) Class A1  
EN54-7 (2000)  
Point type smoke and heat detector



©2006 Digital Security Controls  
Toronto, Canada • [www.dsc.com](http://www.dsc.com)  
Tech Support: 1-800-387-3630 (Canada & USA), 905-760-3036  
Printed in Canada