

DSC[®]

LC-171

Dual-Tech Motion Sensor (Dual Element PIR & Microwave) with Pet Immunity

INSTALLATION INSTRUCTIONS & USER MANUAL

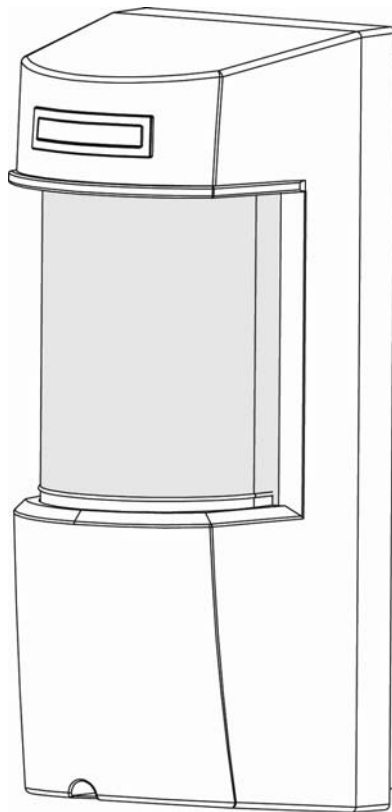

P/N: 7131691 ver.A

1	General.....	3
2	Features	3
3	Assembly description.....	4
4	Detection Pattern.....	5
5	Selecting mounting location.....	6
6	Detector Installation.....	7
7	Terminal Block Connections.....	9
7.1	Wire Size Requirements.....	9
8	Settings & Adjustments	10
8.1	Detection beam direction.....	10
8.2	Detection range setting	10
8.3	Sensitivity, Range and Pet immunity Adjustment	11
8.4	Indications setting.....	13
9	Operation.....	14
10	Test procedure.....	15
11	Specifications.....	16

1 **General**

The LC-171 is unique motion detector utilizing dual passive infra-red elements and Microwave technology for use outdoors and in harsh environments.

The LC-171 is designed for outdoor use in the most severe climatic conditions and may also accommodate pets.

High reliability is achieved by combining both dual tech hardware with highly sophisticated software and an adaptive coverage area, greatly reducing the possibility of false alarms.

The active elements are comprised of a dual element PIR and advanced Microwave detector inside a stylish, rigid plastic body.

This special optics combined with state of the art microwave Doppler sensor assures elimination of "false alarms" while maintaining high security standards for the detection of human intruders into the protected area.

The detection sensitivity and range is controlled by a digital rotary switch allowing 16 calibration levels, so that the correct detection pattern will be set for every installation.

The LC-171 is designed to protect large areas and can easily be installed on walls or poles in order to provide a solid area of protection while rejecting interference from birds and small animals due to the provided pet immunity optics.

2 **Features**

- Microwave detection based on Doppler concept.
- N.O. & N. C. Relays switched at the same time.
- Pet immunity up 35kg.
- 16 levels of PIR sensitivity adjustment and 3 microwave sensitivity groups.
- Temperature compensation.
- Microcontroller signal processing.
- Front and back tamper protection.
- Audible indication of walk test and intruder detection.
- Unique waterproof sealed plastic design.
- Detection Range: Up to 18m
- Detect human intruders walking or running.
- No maintenance required.
- High RFI/EMI Immunity.
- Protection from: direct sunlight, wind up to 30 m/sec, snow and rain, small animals, removal of the top cover and removal from mounting bracket

3 Assembly description

The LC-171 is a robust detector which includes a large LED indicator that can be easily observed from long distances and an optional buzzer to provide indication of intrusion.

Using the supplied mounting bracket, the LC-171 can be easily mounted to walls using mounting screws and poles using the supplied metal bands.

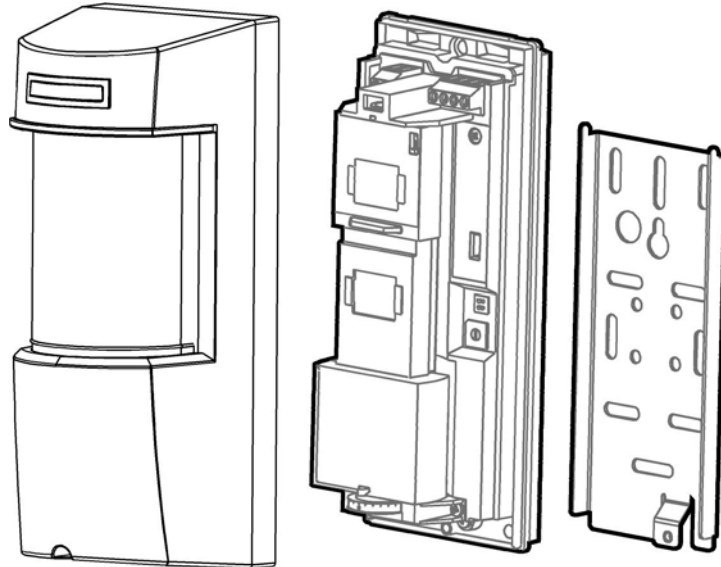

The LC-171 is combined of three detection elements:

- Upper PIR element
- Lower PIR element
- Microwave element
- The upper PIR element has an adjustable detection height while the other two are fixed.

The following drawing shows all internal elements:

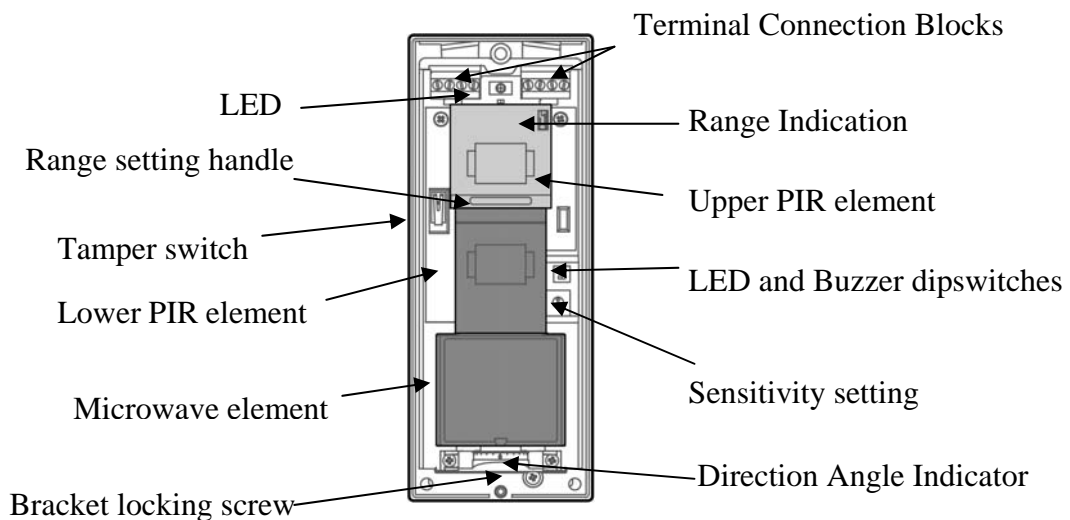

4 Detection Pattern

The LC-171 has a 90° top view PIR and MW detection pattern with over 18m detection distance (when installed at 1.2m above the ground surface).

The LC-171 has an internal rotating housing (which includes the 2 PIR elements and the MW) that can be adjusted horizontally, so its 90° coverage may vary between 0° and 180°.

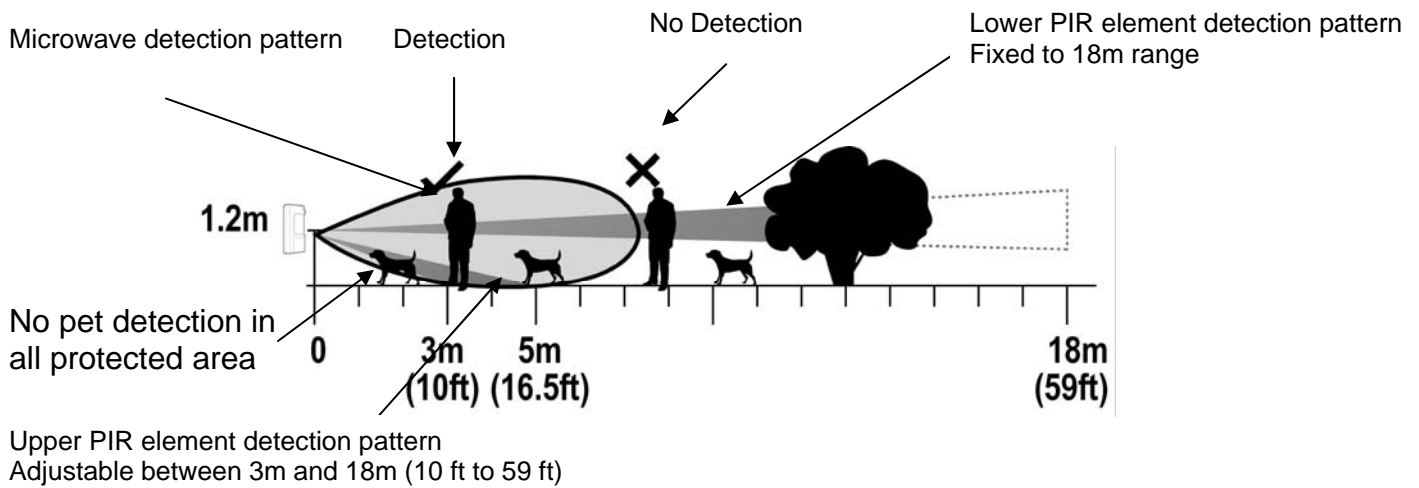
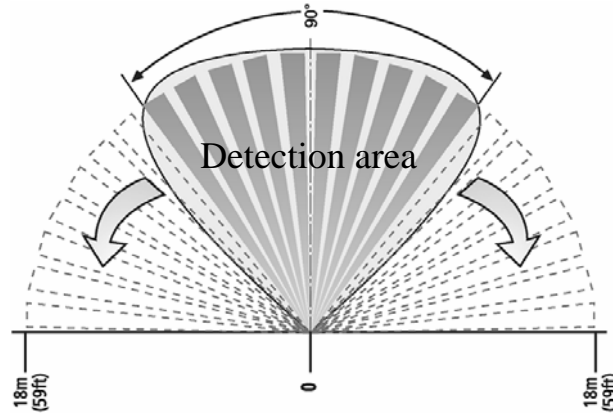

The LC-171 can differentiate between pets and human bodies and alert accordingly by having microwave movement detection combined with two PIR detection beams:.

- A. Lower PIR element which is fixed to 18m range and 60cm above ground level which helps avoiding pet detection over the entire area.
- B. Upper PIR element which has adaptive range between 3 and 18m.

An intrusion is defined by both PIR detection beams being crossed and a Microwave detection occurring, causing an alarm.

No alarm will be generated if only one of the PIR detection beams is crossed and microwave detection occurs.

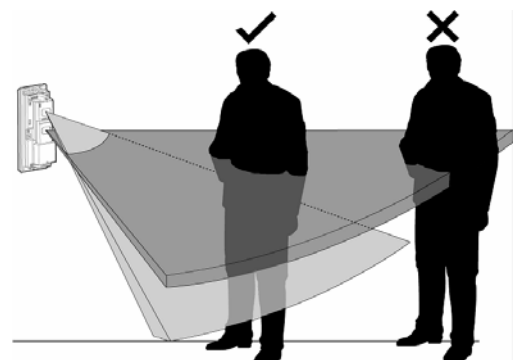

5 Selecting mounting location

The installation of the LC-171 requires a solid, level base for the mounting bracket and must be located in a manner that when the detector is mounted, it is facing the center of the desired detection zone.

The protected area must be free from obstacles like walls, fences, trees, ditches and other microwave detectors.

Choose a location most likely to intercept an intruder according to detection pattern on page 5.

Avoid the Following Installation Locations:

- Facing direct sunlight.
- Facing areas subject to rapid temperature changes.
- Mounted at more than 10° from the vertical or horizontal plane.
- Facing metal doors.
- Near direct sources of heat or airflow.
- Clear all physical obstacles from the detection area (e.g. Plants, laundry, etc.)
- Clear all light reflecting surfaces from the detection area, including puddles or other standing water.
- Avoid installation on the following types of ground:
Thick vegetation, Grass (un-mown), Water, Sand and Metal.

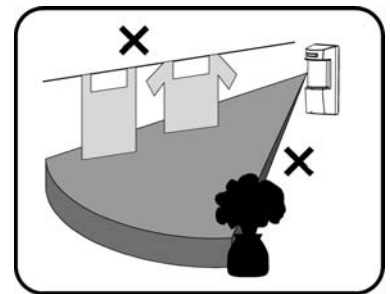
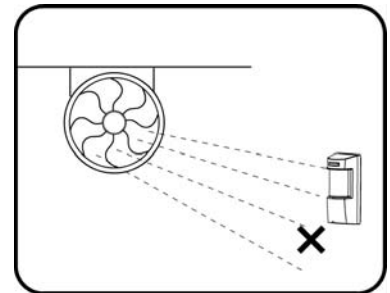

NOTE:

Recommended installation height is 1.2m.

The DOUBLE DUAL high quality sensor detects motion crossing the beam; it is less sensitive detecting motion towards the detector.

The LC-171 performs best when provided with a constant and stable environment.

In order to ensure suitable operation of the LC-171 type of ground should be one of the following:
Asphalt concrete, Cement, Soil, Clay, Gravel or Grass (mown).

6 Detector Installation

Important! Prior to installation, read both “Operation” and “Selecting the mounting location” sections carefully.

1. Install the detector in such manner that the intruder is most likely to cross the detection area from side to side.

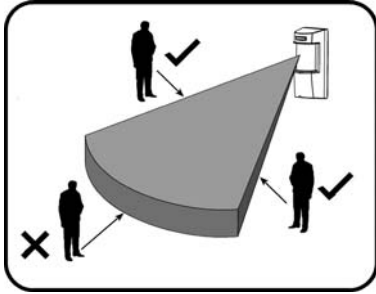

2. The detector is to be installed at height of 0.8 to 1.5 meter (ideally 1.2m)

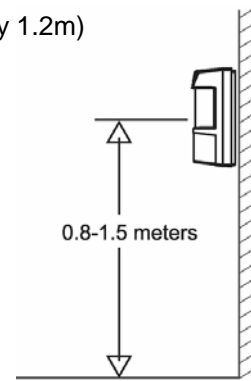

3. Make sure to attach the metal bracket to a leveled straight and firm wall, leaving 15cm from the top and 15cm from both sides, for easy installation and maintenance.

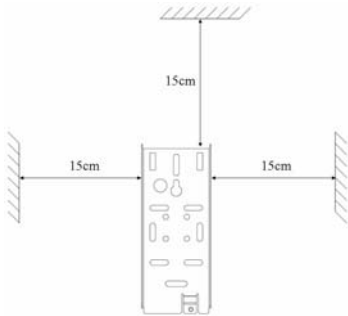

4. Rotating the detection beam may be required for guarding a side window opening while the detector is installed facing another direction.

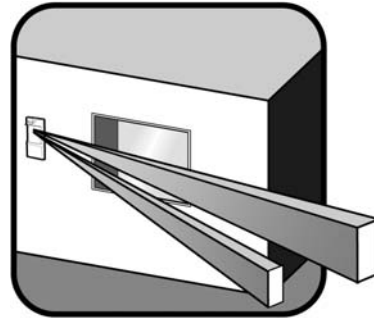

5. Open the detector unwinding the bottom screw.

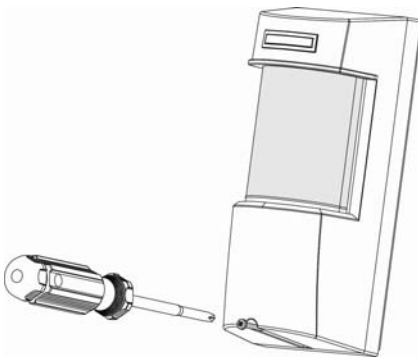

6. Release the rear metal bracket by unwinding internal bottom screw.

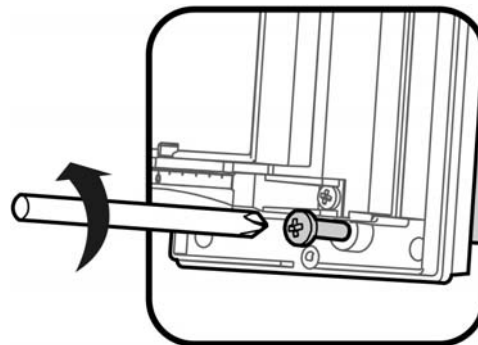

7. Release the detector body from the metal bracket by pulling the detector out and up.

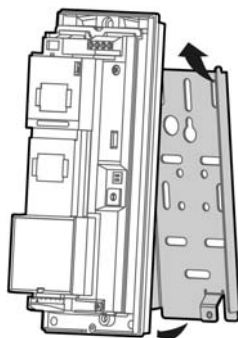

8. Attach the rear bracket to the wall or a pole using mounting screws or metal bands.

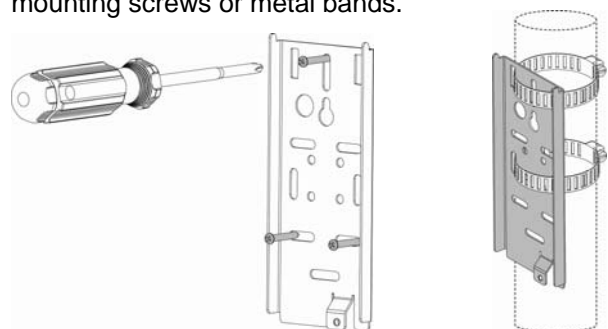

9. Break the relevant knockouts on the rear side of the plastic base and slide the wires from the outside via the paths and knockout to the internal side of the detector.

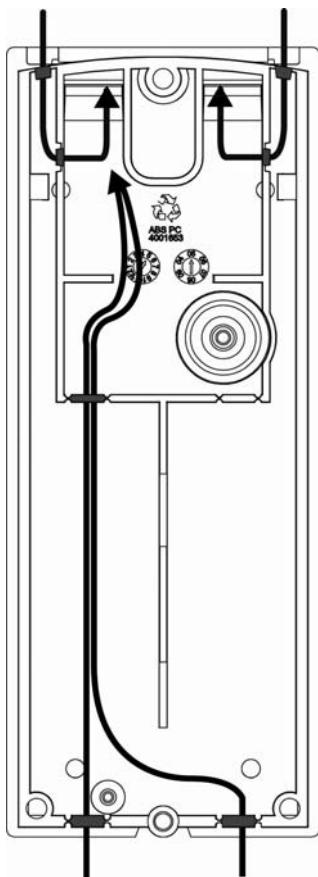

10. Attach the sealing "U" shaped Sponge Pad to the wire opening from the rear side after the wires have been connected and prior to final product affixing to the mounted bracket.

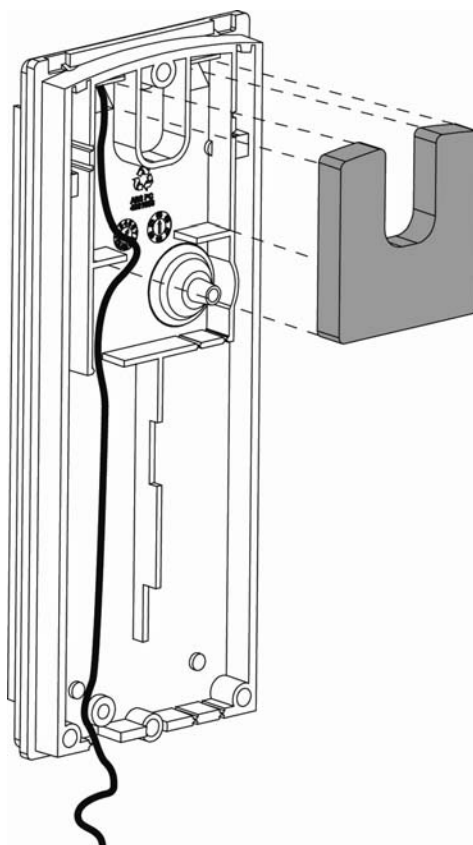

11. Place the detector on the mounting bracket from top side down and then lock the screw at the bottom.

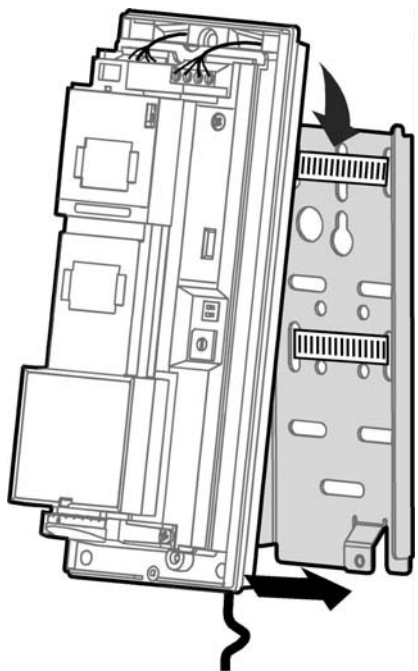

12. Connect the wires to the terminal blocks according to the following chapter.

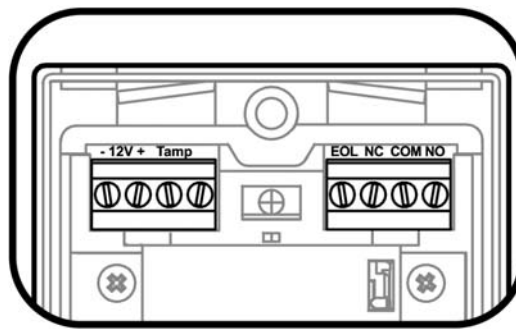

7 Terminal Block Connections

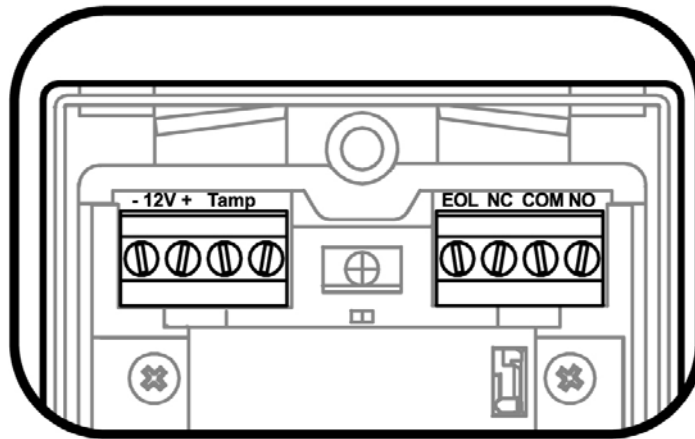

Terminal 1 - Marked “-” (GND) - Connect to the ground of the Control Panel.

Terminal 2 - Marked “+” (+12V) - Connect to a positive Voltage of 9.6 -16Vdc source (usually from the Control Panel)

Terminals 3 & 4 - Marked “TAMP” - If a Tamper function is required connect these Terminals to a normally closed 24-Hour Tamper Zone on the Control Panel.

If the top cover of the detector is opened or the detector is detached from installation wall, an immediate alarm signal will be sent to the Control Panel.

Terminal 5 - Marked “EOL” - End of line – optional terminal for end of line resistors connections.

Terminals 6, 7 & 8 - Marked “NC / C / NO” - These are the output relay contacts of the detector. Connect to a zone input on the control unit. When an intruder is detected, alarm relays (N.C. and N.O.) will switch for 1.8 sec.

7.1 Wire Size Requirements

Use #22 AWG or larger wires. Use the following table to determine required wire gauge and length.

Wire Length [m]	205	310	510	870
Wire Length [ft.]	800	1200	2000	3400
Wire Gauge [#]	22	20	18	16

8 Settings & Adjustments

8.1 Detection beam direction

The LC-171 detection beam direction may vary between 0° and 180°.

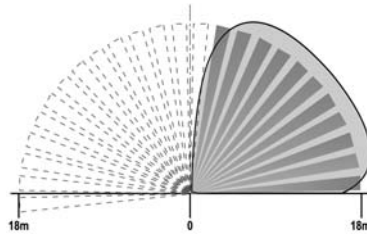

In order to change the detection beam direction rotate the internal detection element housing to the desired direction.



8.2 Detection range setting

The LC-171 detection range may vary between 3m and 18m, while installed on 1.2m height above the ground surface.

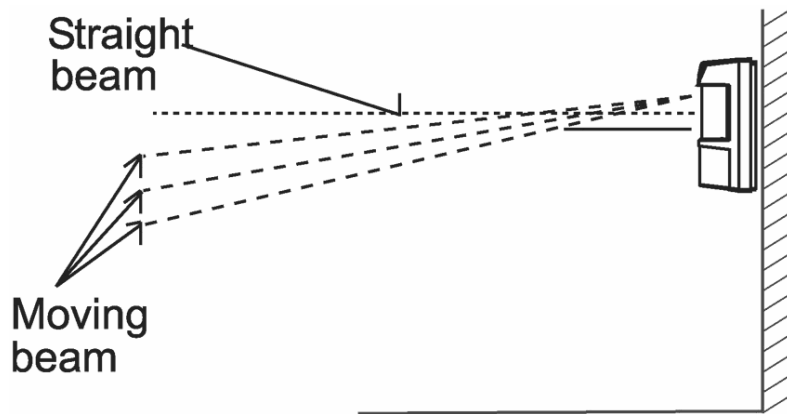

Changing the detection range is achieved by sliding the upper detection element up or down.

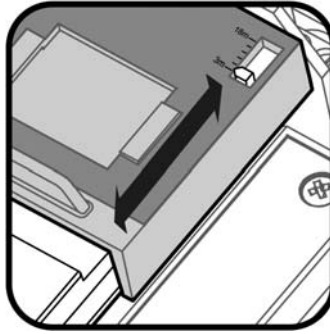

To adjust for ranges between 3m and 18m slide the detection element up or down to correspond with the desired distance. Each step between 3m and 18m represents 3m of range.



8.3 Sensitivity, Range and Pet immunity Adjustment

The calibration of range and sensitivity is performed by a single 16 position rotating switch. There are 3 groups of switch settings grouped according to desired detection range. Each group is divided into several levels of sensitivity according to the installation environment.

The sensitivity is determined by a single 16 position rotating switch. Changing the sensitivity affects immunity to environmental noises, and also affects the detection distance and pet immunity level.

The rotating switch is marked with digits from “0” to “9” and following letters from “A” to “F”. Position “0” is maximum sensitivity and “F” is minimum sensitivity.

Note: Adjust sensitivity according to environmental conditions!

Group A - positions 0 – 5 – set sensitivity for 18m detection range with immunity to pets weight up to 20kg

Group B - positions 6 – A – set sensitivity for 13m detection range with immunity to pets weight up to 35kg

Group C - positions B – F – set sensitivity for 7m detection range with immunity to pets weight up to 35kg

NOTE: Ensure that you select the group with a range corresponding to or slightly higher than the range set in 8.2. Do not select a group setting that has a lower range than the range set in 8.2.

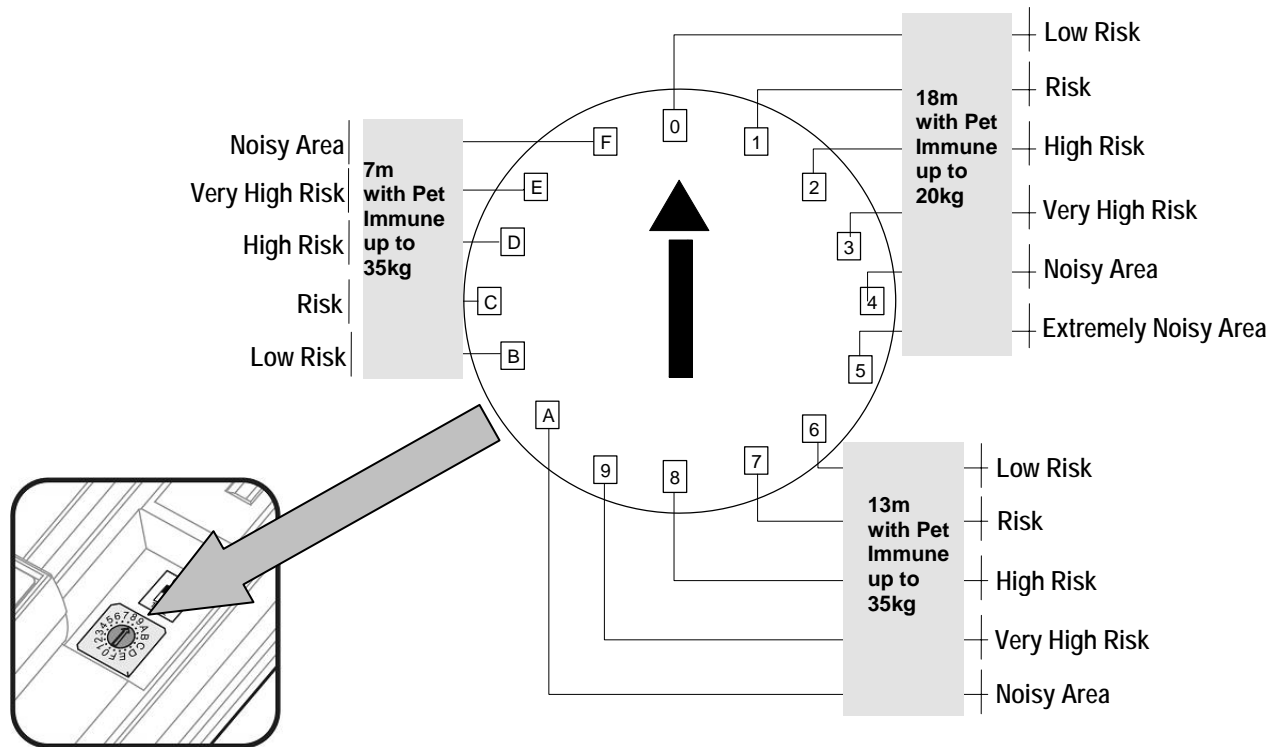

Each group is divided to 5 or 6 sub-positions that help to define the environmental condition inside the detection range:

- **Low risk:** very stable environment without interference from parking garages, parking spaces, playgrounds, football fields, service roads, etc.
- **Risk:** Stable environment with some trees, bushes, flowerpots, planters.
- **High risk:** Unstable environment with different types of vegetation and grass and puddles.
- **Very high risk:** Unstable environment with winds and small pets, rats, mice, birds.
- **Noisy area:** Unstable environment with vegetation and water sources like swimming pool, lake, canal, weeds as well as small pets like cats and rabbits.
- **Extremely Noisy area:** Very unstable environment subject to wind, snow, rain, with vegetation, water and large pets, such as dogs.

For example:

If detector is used for 13m (42 ft) range in open space with sunlight and pets, set switch to position 9.

8.4 Indications setting

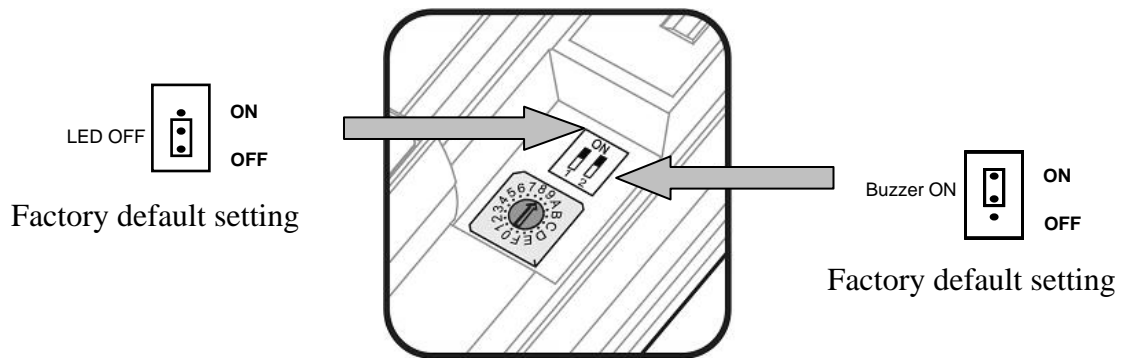

The LC-171 has two types of indicators:

1. LED
2. Buzzer

The installer can adjust both indicators operation during detection (ON or OFF) by using switch number "1" for the buzzer and switch number "2" for the LED. When the LED indicator is ON the LED indicator will activate for 1 second each time an intrusion is detected. When the LED indicator is OFF the LED will not be used to indicate an intrusion has occurred.

When the Buzzer indicator is ON the Buzzer will activate for 1.8sec each time an intrusion is detected. When the Buzzer indicator is OFF the buzzer will not be used to indicate an intrusion has occurred. (Setting the buzzer ON gives the installer the ability to have audible confirmation of intrusion detection during the adjustments and a walk test. After completing adjustments and walk testing it is recommended to switch the buzzer OFF)

- Place the top cover to the base and close it using the bottom screw.

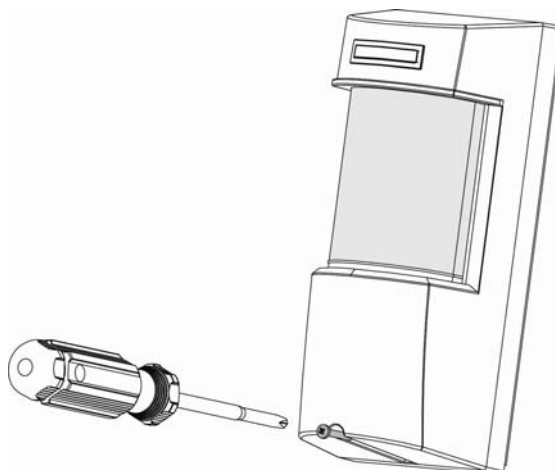

9 **Operation**

Note! Connect the LC-171 to a positive Voltage output of 9.6 -16VDC source.

Use only a listed power limited source.

The detector shall be provided with minimum of 4 hours of standby power from either a listed compatible control unit or power supply.

- The detector begins a 2 minute warm up period once connected to power.
- The LED will flash for the first 30 seconds of the warm up period after power up. The device is operational once the LED stops flashing
- The warm up period will continue for 90 seconds after the LED stops flashing
- Once the warm up period is complete the device is ready for use

10 Test procedure

Walk Test

IMPORTANT NOTE: Once installed, the unit should be thoroughly tested to verify proper operation and coverage. After installation, the unit should be tested annually by the installer. The end user should be instructed on how to perform a weekly walk test.

Ensure that the detector has completed the 2 minute warm up period before walk testing

Make sure that the protected area is cleared of all people.

Create motion in the entire area where coverage is desired by walking perpendicular to the detection pattern.

Listen to ALARM sound whenever motion is detected (the red LED also turns ON whenever motion is detected).

Allow 5 sec. between each test for the detector to stabilize.

Walk across the entire area where coverage is desired. Should the coverage be incomplete, readjust coverage range or relocate the detector.

Once coverage is as desired, the buzzer and LED should be disabled.

11 Specifications

Detection Method	Dual PIR AND MW
Microwave Frequency	24.125 GHz
Power Input	9.6 to 16Vdc
Current Draw	Active: 24mA (±5%) Standby: 21mA (±5%)
Temp Compensation	Yes, Dual slope temperature compensation
Alarm Period	2 sec (±0.5sec)
Alarm Outputs	Form C (NC, NO, Common) 28Vdc 0.1 A with 10 Ohm series protection resistor
Tamper Switch(s)	Two Switches N.C 28Vdc 0.1 A with 10 Ohm Series protection resistors Opens when cover is removed from unit's base or if base is removed from wall
Warm up Period	120sec (± 5sec)
LED Indicator	LED is ON during ALARM (configurable)
RF Immunity	10 V/m plus 80% AM from 80 MHz to 2GHz
ElectroStatic Immunity	6kV contact, 8kV air
Transient Immunity	1kV
Operation Temp	-35°C ~ +55°C
Dimensions	200mm x 86mm x 80mm
Weight	500gr.
European directives	RTTE directive:1999/5/EC EMC directive: 2004/108/EC Low Voltage directive: 2006/95/EC RoHS directive: 2002/95/EC
European standards requirements:	EN300 440-2; EN301 489-1; EN50130-4 +A1 +A2; EN61000-6-3+A11 EN60950-1 EN50131-1 / EN50131-2-4 / EN50130-5
USA & Canada	47CFR part 15, subpart C, section 15.245; 47CFR part 15, subpart B RSS210; ICES-003
Protection Degree	IEC 60529: IP 65

- Specifications are subject to change without prior notice.

FCC COMPLIANCE STATEMENT

FCC ID: F5309LC171

CAUTION: Changes or modifications not expressly approved by Digital Security Controls could void your authority to use this equipment.

This equipment generates and uses radio frequency energy and if not installed and used properly, in strict accordance with the manufacturer's instructions, may cause interference to radio and television reception. It has been type tested and found to comply with the limits for Class B device in accordance with the specifications in Subpart "B" of Part 15 of FCC Rules, which are designed to provide reasonable protection against such interference in any residential installation. However, there is no guarantee that interference will not occur in a particular installation. If this equipment does cause interference to television or radio reception, which can be determined by turning the equipment off and on, the user is encouraged to try to correct the interference by one or more of the following measures:

- Re-orient the receiving antenna
- Relocate the alarm control with respect to the receiver
- Move the alarm control away from the receiver
- Connect the alarm control into a different outlet so that alarm control and receiver are on different circuits.

If necessary, the user should consult the dealer or an experienced radio/television technician for additional suggestions. The user may find the following booklet prepared by the FCC helpful: "How to Identify and Resolve Radio/Television Interference Problems". This booklet is available from the U.S. Government Printing Office, Washington, D.C. 20402, Stock # 004-000-00345-4.

INDUSTRY CANADA COMPLIANCE STATEMENT

IC:160A-LC171

The term 'IC:' before the radio certification number only signifies that Industry Canada technical specifications were met.

This Class B digital apparatus complies with Canadian ICES-003

Cet appareil numérique de la classe B est conforme à la norme NMB-003 du Canada.

RTTE Compliance Statement:

DSC erklærer herved at denne komponenten overholder alle vigtige krav samt andre bestemmelser gitt i direktiv 1999/5/EC.

Por este meio, a DSC, declara que este equipamento está em conformidade com os requisitos essenciais e outras determinações relevantes da Directiva 1999/5/EC.

"DSC bekräftar härmed att denna apparat uppfyller de väsentliga kraven och andra relevanta bestämmelser i Direktivet 1999/5/EC".

Con la presente la Digital Security Controls dichiara che questo prodotto è conforme ai requisiti essenziali ed altre disposizioni rilevanti relative alla Direttiva 1999/05/CE.

Por la presente, DSC declara que este equipo está en conformidad con los requisitos esenciales y otros requisitos relevantes de la Directiva 1999/5/EC

Hierdurch erklärt DSC, daß dieses Gerät den erforderlichen Bedingungen und Voraussetzungen der Richtlinie 1999/5/EC entspricht.

'Δια του παρόντος, η DSC, δηλώνει ότι αυτή η συσκευή είναι σύμφωνη με τις ουσιαστικές απαιτήσεις και με όλες τις άλλες σχετικές αναφορές της Οδηγίας 1999/5/EC'.

Hierbij verklaart DSC dat dit toestel in overeenstemming is met de eisen en bepalingen van richtlijn 1999/5/EC.

Par la présente, DSC déclare que cet article est conforme aux exigences essentielles et autres stipulations de la directive 1999/5/EC.

DSC vakuuttaa laitteen täyttävän direktiivin 1999/5/EC olennaiset vaatimukset.

Hereby, DSC, declares that this device is in compliance with the essential requirements and other relevant provisions of Directive 1999/5/EC.

The complete R & TTE Declaration of Conformity can be found at www.dsc.com/intl/rttedirect.htm.

CLASS 2



24.125 GHz

No restrictions in all European countries, except for Spain.



Limited Warranty

Digital Security Controls warrants that for a period of 12 months from the date of purchase, the product shall be free of defects in materials and workmanship under normal use and that in fulfillment of any breach of such warranty, Digital Security Controls shall, at its option, repair or replace the defective equipment upon return of the equipment to its repair depot. This warranty applies only to defects in parts and workmanship and not to damage incurred in shipping or handling, or damage due to causes beyond the control of Digital Security Controls such as lightning, excessive voltage, mechanical shock, water damage, or damage arising out of abuse, alteration or improper application of the equipment. The foregoing warranty shall apply only to the original buyer, and is and shall be in lieu of any and all other warranties, whether expressed or implied and of all other obligations or liabilities on the part of Digital Security Controls. Digital Security Controls neither assumes responsibility for, nor authorizes any other person purporting to act on its behalf to modify or to change this warranty, nor to assume for it any other warranty or liability concerning this product.

In no event shall Digital Security Controls be liable for any direct, indirect or consequential damages, loss of anticipated profits, loss of time or any other losses incurred by the buyer in connection with the purchase, installation or operation or failure of this product.

Motion detectors can only detect motion within the designated areas as shown in their respective installation instructions. They cannot discriminate between intruders and intended occupants. Motion detectors do not provide volumetric area protection. They have multiple beams of detection and motion can only be detected in unobstructed areas covered by these beams. They cannot detect motion which occurs behind walls, ceilings, floor, closed doors, glass partitions, glass doors or windows. Any type of tampering whether intentional or unintentional such as masking, painting, or spraying of any material on the lenses, mirrors, windows or any other part of the detection system will impair its proper operation.

Passive infrared motion detectors operate by sensing changes in temperature. However their effectiveness can be reduced when the ambient temperature rises near or above body temperature or if there are intentional or unintentional sources of heat in or near the detection area. Some of these heat sources could be heaters, radiators, stoves, barbeques, fireplaces, sunlight, steam vents, lighting and so on.

Warning: Digital Security Controls recommends that the entire system be completely tested on a regular basis. However, despite frequent testing, and due to, but not limited to, criminal tampering or electrical disruption, it is possible for this product to fail to perform as expected.

Important Information: Changes or modifications not expressly approved by Digital Security Controls could void the user's authority to operate this equipment.