

ZBAMB4300 Sync Access Point

*Installation Guide for Lowe's®
Hardware Stores*

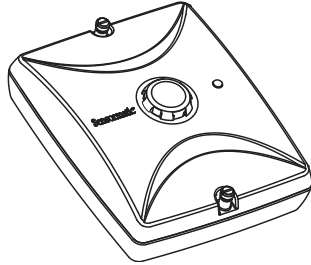

The ZBAMB4300 Sync Access Point (Sync AP) is an AC line zero-crossing detector that can transmit zero crossing data to nearby ZBAMB2070 Mobile Handheld Deactivators to prevent detection interference with nearby EAS detectors.

This guide explains only how to install the Sync AP in a Lowe's hardware store. For setup instructions, see *ZBAMB4300 Sync AP Connection and Setup Guide* 8200-0958-06.

If you need assistance...

Contact your Sales Representative.

Installation Locations

On the wall near the main or lumber entrance



In the Universal Outdoor Enclosure near the garden center entrance.



OR



Safety



WARNING:

- Install the AP in an air space not used for environmental air. DO NOT install it in a plenum or other environmental air-handling space.
- Cables placed in environmental airspace must be plenum rated unless the cables are in raceways.
- All wiring must be through conduit.
- Ensure that all safety instructions within this manual are continuously observed and respected during the installation and/or operation of this device.
- Mount the AP only as shown in this guide. Mounting the module any other way may affect its operation.
- The manufacturer is **not** responsible for any radio or TV interference caused by unauthorized modifications to this equipment. Such modifications could void the user's authority to operate the equipment.
- The antennas used for this transmitter must be installed to provide a separation distance of at least 20cm (8in) from all persons and must not be collocated or operating in conjunction with any other antenna or transmitter.

Parts Required

Supplied

Part	Qty.	Part Number
Power Supply Module*	1	5606-0079-01
Install Kit (indoor install only)	1	0352-0580-01
Connector, Female, RJ45	1	2109-0717-01
Cable, Cat5, 4.6m (15ft)	1	6003-0266-02
Coupler, Female-to-Female, Cat5	1	2109-0906-01

* Includes power cord 0352-0547-xx.

Not Supplied (Order Separately)

Part	Qty.	Part Number
Install Kit (for outdoor enclosure)	1	0352-0591-01
Bracket, Mounting	1	0505-1544-01
Bracket, Corner/Wall Mount	1	0500-7844-01
Screw, Self-Tapping, PHP, #6x3/4in	4	2816-7634-32
Screw, Tapcon, HXWH, 3/16x3/4in	4	2816-7683-02
Drill Bit, Tapcon, 5/32x3-1/2in	1	2816-7683-10
Anchor, HLW Wall, 1/4-20, 1/8-5/8	4	2880-0025-02
Screw, Mach, M3x8, PHP (not used)	1	5801-1051-120
Screw, Self-Tapping, 8x32, PHP	4	5810-5091-120
Nut, Locking, M3 (not used)	2	5826-0200-020
Nut, Locking, M4	4	5826-0300-020

Purchase

Part	Qty.
3/4-inch Conduit, Preferred (as required)	–
4x4 Electrical Box, Deep	1

Installation A: Main/Lumber Entrance

For the garden center entrance, see Installation B.

Electrical Connection Points

The electrical connections near the EAS system are generally the same, but may vary from store to store. A typical scenario is described below.

Power Cable Route

The power cable route goes from:

- The AC outlet inside the main electrical box in which the power supply module (1) and female-to-female coupler (2) reside.
- Down through existing conduit into the UltraLink enclosure below.
- Up through existing conduit and alarm module electrical box (3).
- To a 4x4 electrical box (4) mounted 3.7m (12ft) from the floor (the Sync AP mounts here using two screws as shown below). A length of conduit (5) will need to be added for power to reach this box.

Notes:

The 4.6m (15ft) Cat5 cable supplied is used to get power to the Sync AP.

DO NOT connect this cable to the Sync AP or the female-to-female coupler inside the main electrical box at this time. These connections will be done at the end of the setup process.

If the cable does not fit through the conduit, then cut off one of its connectors close to the end of the cable, route the cable, then reattach the connector (see page 5 for reattachment instructions).

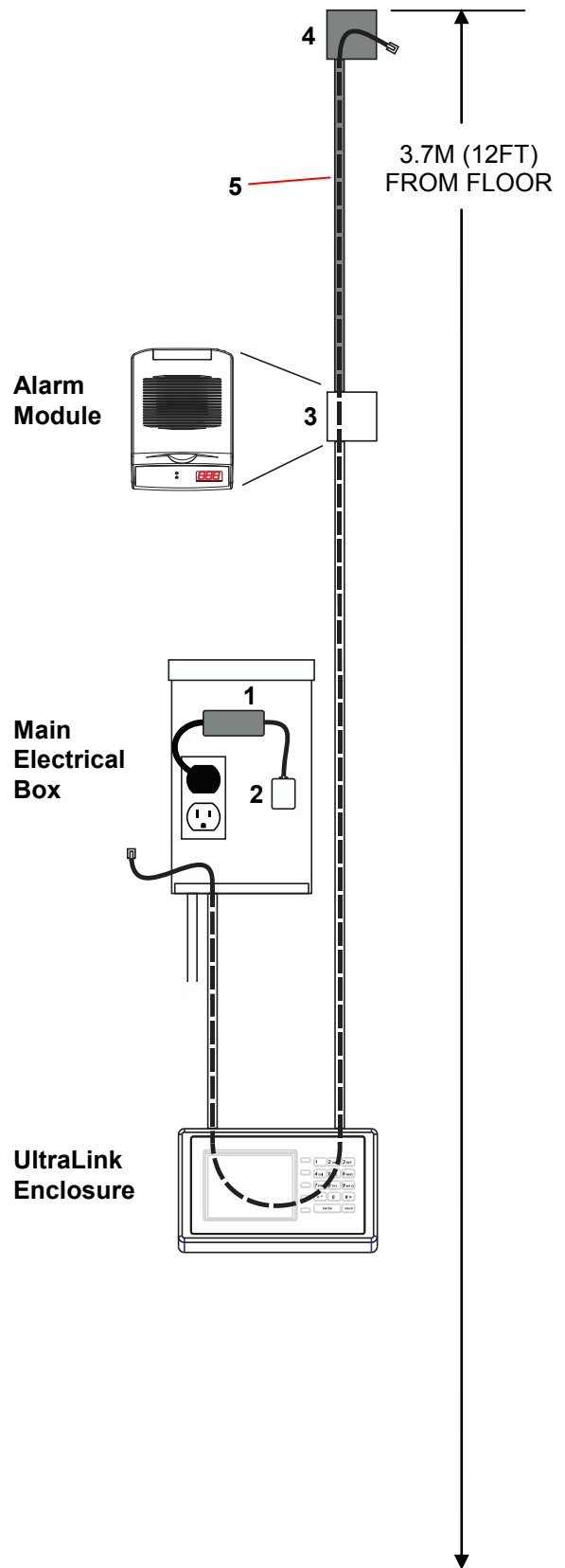
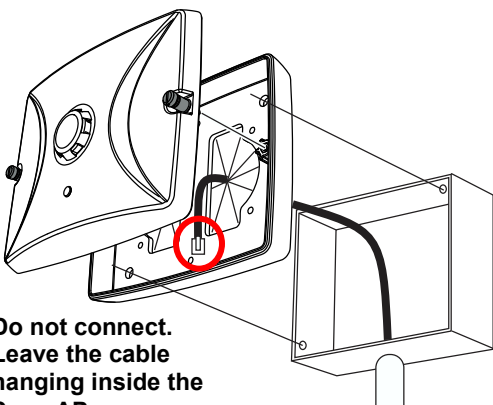

Installation B: Garden Center Entrance

For the main/lumber entrance, see Installation A.

Electrical Connection Points

The location of electrical connection points near the EAS system is generally the same for each store, but details may vary from store to store. These instructions cover a typical scenario.

Sync AP Mounting Location

Mount the Sync AP in the Universal Outdoor Enclosure.

- **If the enclosure has a drop-down floor-max fiberglass panel:** Drill an access hole in the fiberglass for the cable and mount the Sync AP where shown. Plug the power supply into the AC outlet in the enclosure and route its cable up through the drop-down panel and through the access hole.

DO NOT connect the cable to the Sync AP. This will be done during the setup process.

- **If the enclosure DOES NOT have a drop-down floor-max fiberglass panel:** Mount the Sync AP in the interior upper-left corner of the enclosure using optional mounting bracket 0505-1544-01* and four screws. Plug the power supply into the AC outlet in the enclosure and route its cable up behind the bracket. Attach the Sync AP to the bracket using two screws and connect the cable to the Sync AP.

DO NOT connect the cable to the Sync AP. This will be done during the setup process.

* Order Sync AP Mounting Bracket Install Kit 0352-0591-01.



- OR -



RJ45 Pin Assignments

Male plug pin assignments are according to the T-568B standard. All connections are “straight through” from plug to plug, that is: pin 1 to pin 1, pin 2 to pin 2, and so on

Pin	Wire Color
1	Orange/White
2	Orange
3	Green/White
4	Blue
5	Blue/White
6	Green
7	Brown/White
8	Brown

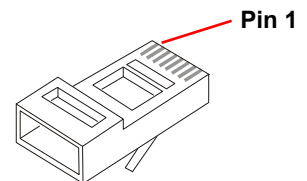

Specifications

Electrical

AC input..... 100–240V @ 47-63Hz
DC Input 18Vdc @ 1.7A

Radio Module

Data communication:

Wireless802.15.4
Data rate 250Kbps
Frequency range..... 2.4GHz ISM band,
2405MHz–2480MHz
Output power..... 5mW, +7dBm Max. (boost mode)
Spreading techniqueDirect Sequence Spread
Spectrum (DSSS)
EAS synchronization..... Wireless EAS
Sync-AP receiver
with internal antenna

Under Industry Canada regulations, this radio transmitter may only operate using an antenna of a type and maximum (or lesser) gain approved for the transmitter by Industry Canada.

To reduce potential radio interference to other users, the antenna type and its gain should be so chosen that the equivalent isotropically radiated power (e.i.r.p.) is not more than that necessary for successful communication.

Conformément à la réglementation d'Industrie Canada, le présent émetteur radio peut fonctionner avec une antenne d'un type et d'un gain maximal (ou inférieur) approuvé pour l'émetteur par Industrie Canada.

Dans le but de réduire les risques de brouillage radioélectrique à l'intention des autres utilisateurs, il faut choisir le type d'antenne et son gain de sorte que la puissance isotrope rayonnée équivalente (p.i.r.e.) ne dépasse pas l'intensité nécessaire à l'établissement d'une communication satisfaisante.

Antenna: 2.4GHz Internal (inverted F type PCB trace)

Environmental

Operating temperature..... 32 to 122°F (0 to 50°C)
Relative humidity 0 to 90% non-condensing

Mechanical

Length.....13.995cm (5.5in)
Width 11.495cm (4.5in)
Depth4.291cm (1.7in)
Weight 0.24kg (0.536 lbs)

Declarations

Regulatory Information

FCC ID: BVCAMB43

NOTE: This equipment has been tested and found to comply with the limits for a Class B digital device, pursuant to part 15 of the FCC Rules. These limits are designed to provide reasonable protection against harmful interference in a residential installation. This equipment generates, uses and can radiate radio frequency energy and, if not installed and used in accordance with the instructions, may cause harmful interference to radio communications. However, there is no guarantee that interference will not occur in a particular installation. If this equipment does cause harmful interference to radio or television reception, which can be determined by turning the equipment off and on, the user is encouraged to try to correct the interference by one or more of the following measures: reorient or relocate the receiving antenna, increase the separation between the equipment and receiver, connect the equipment into an outlet on a circuit different from that to which the receiver is connected, and/or consult the dealer or an experienced radio/TV technician for help.

IC ID: 3506A-AMB43

Models: ZBAMB4300

This device complies with Industry Canada licence-exempt RSS standard(s). Operation is subject to the following two conditions: (1) this device may not cause interference, and (2) this device must accept any interference, including interference that may cause undesired operation of the device.

Le présent appareil est conforme aux CNR d'Industrie Canada applicables aux appareils radio exempts de licence. L'exploitation est autorisée aux deux conditions suivantes : (1) l'appareil ne doit pas produire de brouillage, et (2) l'utilisateur de l'appareil doit accepter tout brouillage radioélectrique subi, même si le brouillage est susceptible d'en compromettre le fonctionnement.

This Class B digital apparatus complies with Canadian ICES-003.

Cet appareil numérique de la classe B est conforme à la norme NMB-003 du Canada.

EMC 47 CFR, Part 15
ICES-003
RSS-Gen
RSS-210

Safety UL 60950-1 (second edition)
CSA C22.2.60950-1
EN 60950-1

Other Declarations

WARRANTY DISCLAIMER: Sensormatic Electronics, LLC makes no representation or warranty with respect to the contents hereof and specifically disclaims any implied warranties of merchantability or fitness for any particular purpose. Further, Sensormatic Electronics, LLC reserves the right to revise this publication and make changes from time to time in the content hereof without obligation of Sensormatic Electronics, LLC to notify any person of such revision or changes.

LIMITED RIGHTS NOTICE: For units of the Department of Defense, all documentation and manuals were developed at private expense and no part of it was developed using Government Funds. The restrictions governing the use and disclosure of technical data marked with this legend are set forth in the definition of "limited rights" in paragraph (a) (15) of the clause of DFARS 252.227.7013. Unpublished - rights reserved under the Copyright Laws of the United States.

TRADEMARK NOTICE: *Sensormatic* is a registered trademark of Sensormatic Electronics, LLC. Other product names mentioned herein may be trademarks or registered trademarks of Sensormatic or other companies.

No part of this guide may be reproduced in any form without written permission from Sensormatic Electronics, LLC.