

AMS-1140 Detectors

Setup and Service Guide

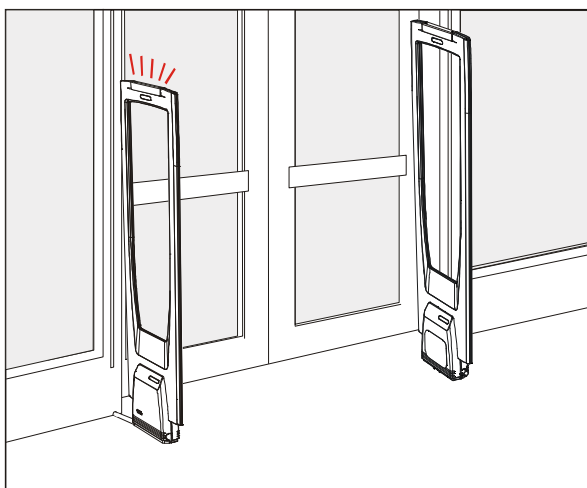

ZA1140-D

Contents

About this Guide	1
Detector Service Features	1
Circuit Board Pinouts	3
Service Procedures	3
Field Replaceable Units	3
Replacing the Secondary Cap Board	3
Replacing the Interconnect Cable	4
Installing the Pedestal Installation Kit	5
Replacing the Alarm Board and Lens	6
Replacing the Fuse	7
Inhibiting the Transmitter	7
Using the Software Configurator	7
Connecting to AC Power	8
Tuning the Pedestals	9
Troubleshooting	10
Checking Detector Operation	10
Dead system/Low sensitivity	10
False Alarms	11
Understanding Error Codes	11
Interpreting LED Indicators	12
Specifications	15
Declarations	15

About this Guide

This guide explains how to tune, service, and troubleshoot AMS-1140 detectors. Related documents are:

- Installation Guide, AMS-1140 Detector, 8200-2684-01

Detector Service Features

AMS-1140 detectors have the following service-related features:

- **Power on self-test.** Upon power up or hardware reset, detector software runs a self-test to ensure it functions.
- **Diagnostics.** You use a laptop computer and configuration software to set up and configure the detector, and to determine its operational status. The detector also has an LED (DS5) inside the primary pedestal that flashes an error code if system software should fail.
- **Alarm indication.** The top cap of the primary pedestal contains flashing LEDs; the base cover of the primary pedestal contains a piezo for an audio alarm. The volume of the audio alarm is controlled with a pot (RV3) on the main circuit board in the primary base cover.
- **Transmit inhibit.** The base of the primary pedestal has a hole that provides access to a transmit-inhibit pushbutton.
- **Tags Too Close indication.** If this feature is enabled by the configurator, the pedestal will flash a unique alarm pattern when a non-deactivated label or tag is left in the detection field of the detector for awhile.
- **Adjacent transmitter interference reduction.** This feature allows service to adjust the Energy Trim Level to decrease the impact of electronic noise from nearby anti-theft systems.
- **Backfield reduction.** If enabled by the configurator, the detector will reduce the size of the detection field behind the pedestals.
- **Simplified design.** AMS-1140 detectors are a simplified design and do not support the following features or options: people-counting, relays, auto-phase, wired sync, jammer detect, auxiliary receivers, remote alarms and external alarm counters.

Figure 1. Primary pedestal main circuit board (0312-3072-01) pinouts

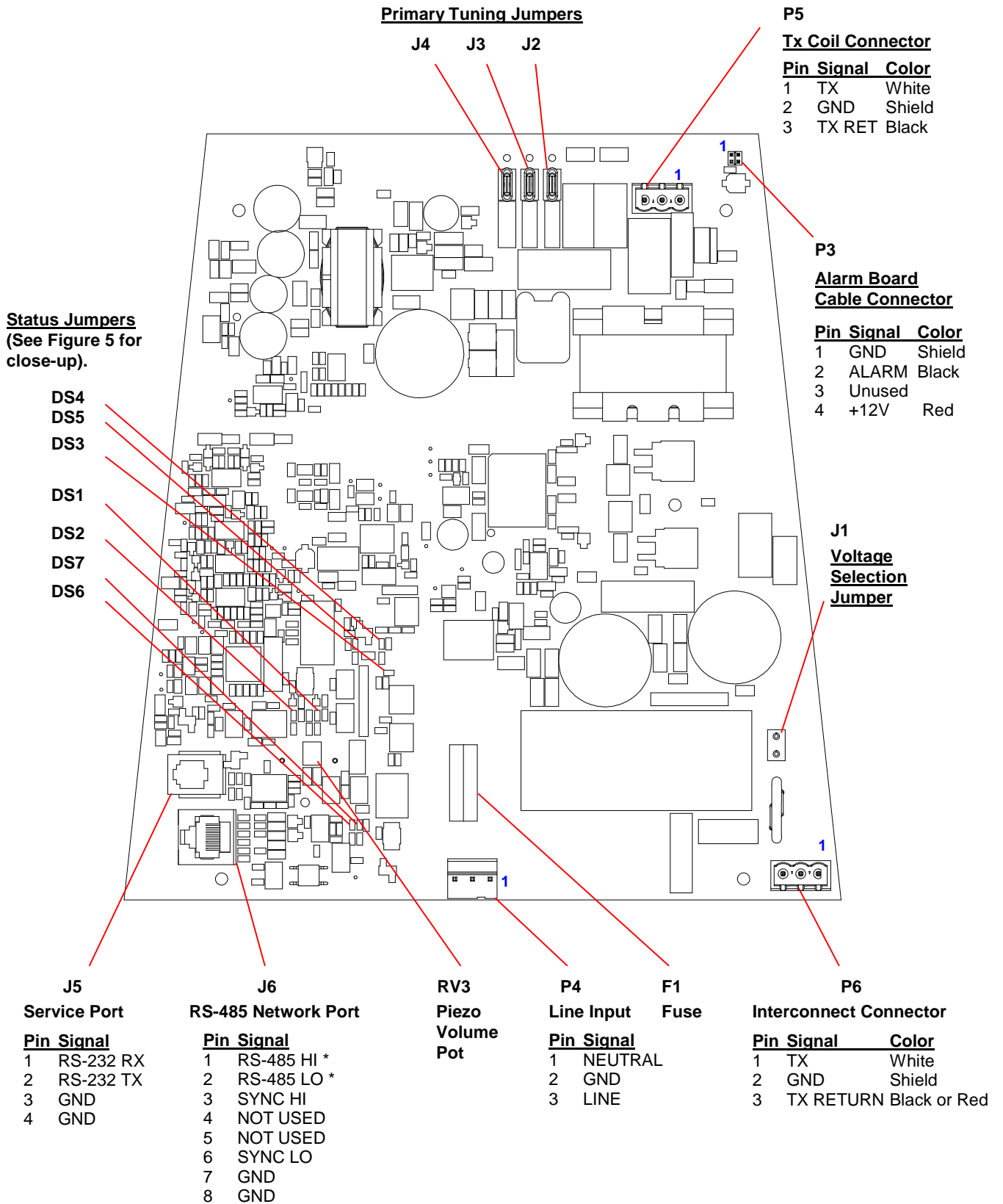

Circuit Board Pinouts

The AMS-1140 pedestals each have a circuit board in their bases. Figure 1 and Figure 2 show the location of connectors, LEDs, jumpers, and fuses, as well as pinouts for the connectors.

Figure 2. Secondary pedestal capacitor board (0312-3075-01) pinouts

P2

Tx Coil Connector

Pin	Signal	Color
1	TX	White
2	GND	Shield
3	TX RETURN	Black

Secondary Tuning jumpers

J1

J2

P1

Interconnect cable connector

Pin	Signal	Color
1	TX	White
2	GND	Shield
3	TX RETURN	Red or Black

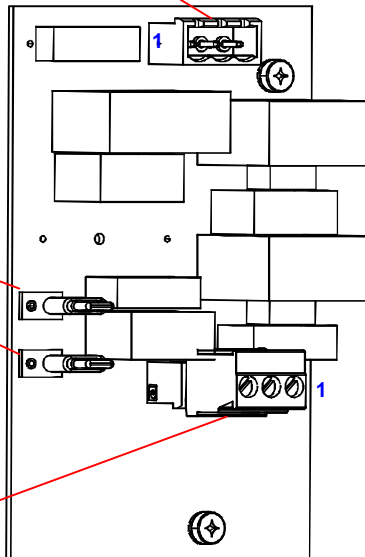

Service Procedures

This section covers the setup and service of the AMS-1140 detector.

Field Replaceable Units

The AMS-1140 has the following Field Replaceable Units (FRU):

Secondary capacitor board	0312-3075-01
Interconnect cable	0652-0506-01
Pedestal installation kit	0352-0444-01
Alarm lens installation kit	0352-0444-02

Replacing the Secondary Cap Board



WARNING—RISK OF ELECTRIC SHOCK! Disconnect AC power when servicing.

1. Turn off power to the pedestal at the circuit breaker.
2. Remove the cover from the exit side of the secondary pedestal. To do this: loosen the four fasteners at the base of the cover, and then lift the bottom of the cover up and then off the base.
3. On the secondary board, disconnect the Tx Coil cable from connector P1 and the primary pedestal from connectors P2. Pull on the connectors, not the wires.
4. Loosen two fasteners securing the capacitor board and remove it from the base cover. Retain the insulator for the replacement board.
5. Use the two fasteners to secure the new capacitor board to the base cover.
6. Reconnect the two cables to the capacitor board.
7. Put the cover back on the base, ensuring that you do not pinch any cables.
8. Tighten the four screws holding the base cover.

Replacing the Interconnect Cable

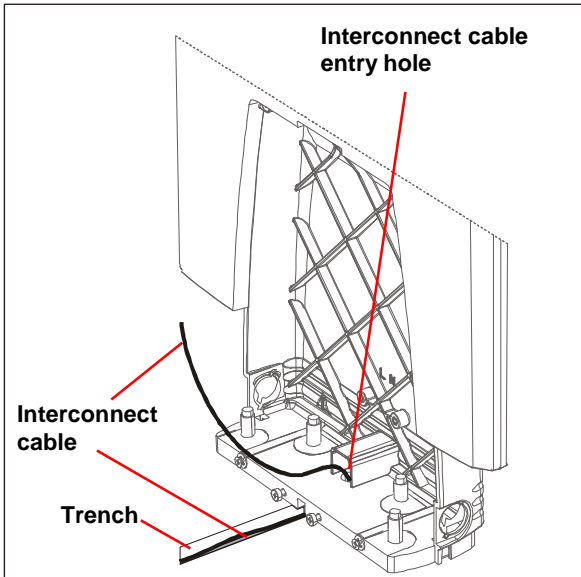

1. Route the interconnect cable through the interconnect cable entry hole on each pedestal. The end of the cable that has been stripped and has heat shrink goes to the primary pedestal; the other end goes to the secondary.

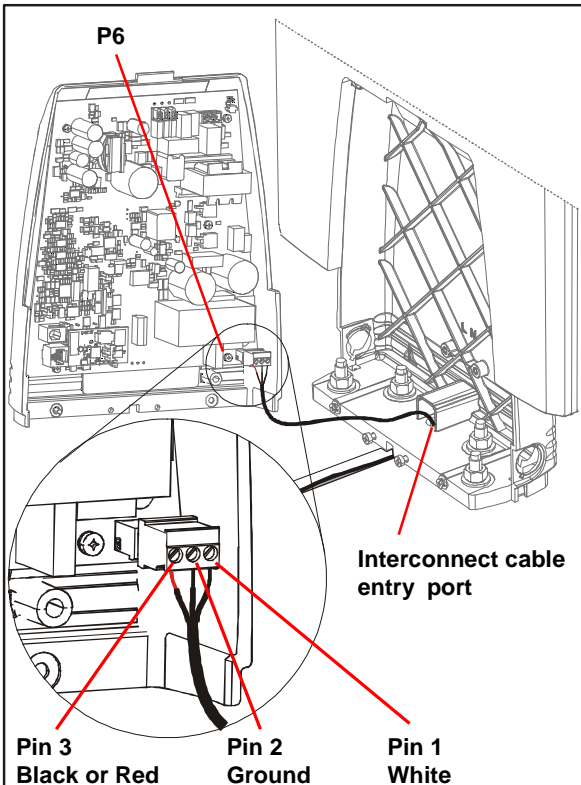

2. Route the interconnect cable through the Interconnect cable entry port on the primary pedestal. Make sure you have the end of the cable that has been stripped and has heat-shrink tubing.



CAUTION: Do not coil any cable inside the base of the primary pedestal.

3. Connect the interconnect cable to the connector plugged into P6 on the main board.
4. Cut the interconnect cable to the proper length, allowing 15cm (6in) of extra cable for future servicing. Strip the ends of the interconnect cable wires.

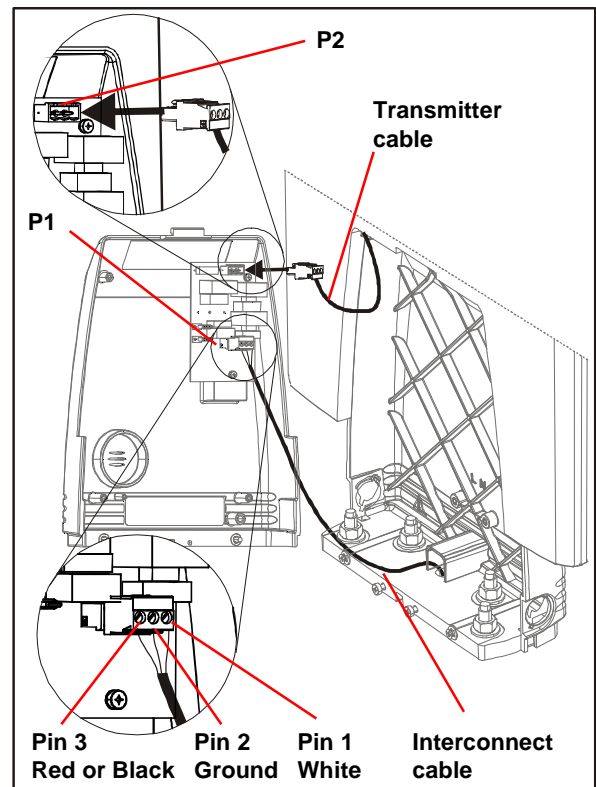

CAUTION: Do not coil any cable inside the base of the secondary pedestal.

5. Connect the interconnect cable to the connector plugged into P1 on the capacitor board in the secondary pedestal. Unlike some other detectors, the secondary pedestal must be connected to the primary in order for the system to work properly.

Installing the Pedestal Installation Kit

The pedestal installation kit contains eight wedge anchors to secure the pedestals to a concrete floor, four hole plugs, two metal plates, one voltage selection jumper, and three conduit clamps.

Installing the wedge anchors and metal plate

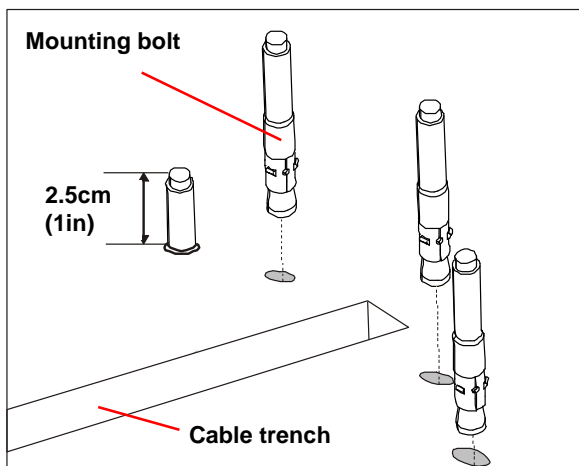

1. Insert the mounting bolts into holes for each base with the threaded end up. The exposed portion of the bolt should be about 2.5cm (1in) in length but must not exceed 3.4cm (1 3/8in). Exposed portion of bolts should be measured from the top of the floor surface (for example, carpeting or wood).
2. Put each pedestal on its bolts.

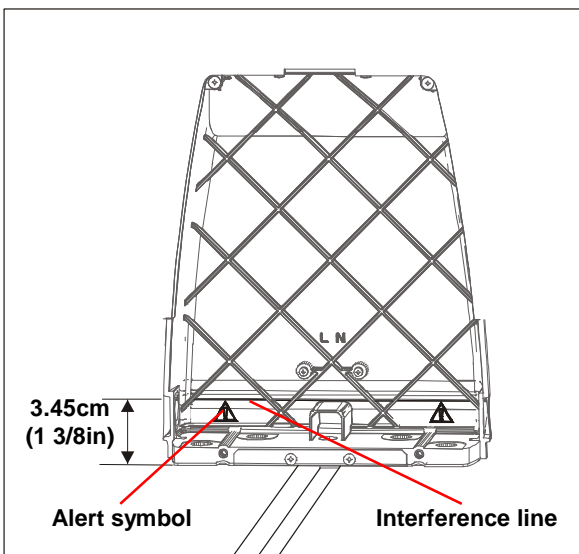

WARNING: The tops of the bolts must not be higher than the interference line that appears above the alert symbol (shown above) that is on the back of the compartment. If the bolts are higher than the line they will interfere with the main circuit board when you install the primary base cover.

3. Gently hit the top of each bolt with a hammer to set the anchor.

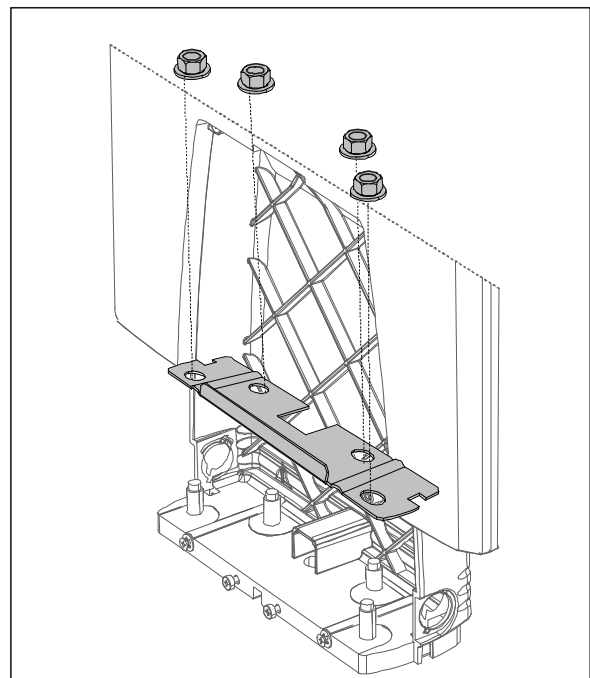

4. Put a metal plate, which is in the pedestal installation kit, over the bolts in each pedestal.
5. Secure the pedestals to the floor with the nuts and washers from the pedestal installation kit.

Installing the hole plugs and conduit clamps

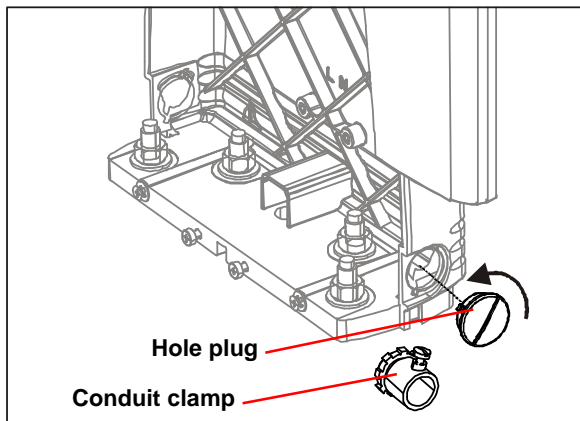

WARNING! DO NOT run the power cable and the Interconnect cable in the same conduit or raceway.

The hole plug and conduit clamps are installed in the side of the pedestal base.

Installing the voltage selection jumper

You must set the voltage selection jumper (J1) on the lower right side of the main circuit board to the proper setting. Refer to Figure 1. The default setting is for 240Vac.



WARNING—RISK OF ELECTRIC SHOCK! Disconnect AC power when servicing.

- For 120Vac operation, install the jumper on J1. The jumper is in the pedestal installation kit.
- For 240Vac operation, remove the jumper from J1 if it is installed.



CAUTION: If you install the jumper for 120Vac and connect the pedestal to a 240Vac supply, the system will be damaged.

If you set a pedestal to 240Vac and connect it to 120Vac power, the system will not operate properly. Also, the system will generate a low current error condition message (error number 21) that can be read with the service configurator software.

Replacing the Alarm Board and Lens

The alarm lens installation kit (0352-0444-02) contains two alarm lens (one for each pedestal), the alarm board, and six screws. You use four of the screws for the two alarm lens. The other two screws are for the grounding plate in the base; they are not needed.



WARNING—RISK OF ELECTRIC SHOCK! Disconnect AC power when servicing.

1. Remove the two screws on the top of the alarm lens.
2. Lift the alarm lens.
3. Disconnect the alarm cable from the alarm board.



CAUTION: The alarm board is fragile; use caution when handling it.

4. Connect the alarm board to the alarm cable connector on the top of the primary pedestal
5. Remove the adhesive backing and stick the alarm board to the center of the top of the pedestal. Make sure you align the arrow on the alarm board with the groove on the top of the pedestal. **Note:** the pedestal top has a slight depression for the alarm board but the alarm board overlaps it when the arrow on the alarm board is properly aligned with the groove.

Replacing the Fuse



WARNING—RISK OF ELECTRIC SHOCK! Disconnect AC power when servicing.

1. Turn off power to the pedestal at the circuit breaker.
2. Remove the cover from the exit side of the primary pedestal. To do this: loosen the four fasteners at the base of the cover, and then lift the bottom of the cover up and then off the base.
3. Remove the cover over the fuse at F1. See **Figure 1** for the location of the fuse.
4. Replace blown fuse F1 with the type and rating marked on the board.
5. Replace the fuse cover.
6. Secure the base cover back on the pedestal.

Inhibiting the Transmitter

Use the transmit-inhibit circuit to determine the cause of unexplained alarms. If the alarm continues when the transmitter is disabled, interference is the likely cause. If the alarm stops when the transmitter is disabled, tags placed too close to the detector are the likely cause.

The transmitter can be inhibited by pressing pushbutton S2 through the hole in front of the base cover on the primary antenna. See the procedure below for instructions on how this works.

Figure 3. Tx-inhibit pushbutton access hole

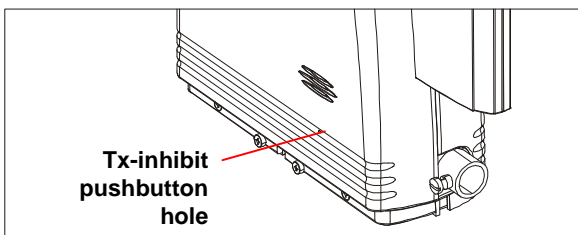

1. Using a pointed instrument such as a straightened paper clip, press the pushbutton.
Note: A beep occurs each time S2 is pressed. The software configurator can disable this feature.

2. Press S2 once to disable the transmitter for 30 seconds (the power LED at the center of the board will flash rapidly).
3. Press S2 a second time within 30 seconds to disable both transmitter and alarm circuits indefinitely (power LED stays on continuously). This prevents continuous alarms until the detector can be serviced.
4. Press S2 a third time to return the detector to routine operation (power LED flashing once per second).

Using the Software Configurator

An AMS-1140 detector can be serviced using the AMS-1140 configurator, which is a software program that runs on a portable (laptop) computer. You can use the configurator at initial installation to modify some aspects of the system's operation per a customer's request, but the configurator is usually used to find out why a system is not working properly and to make adjustments to it to get it working again.

Figure 4. Configurator setup panel

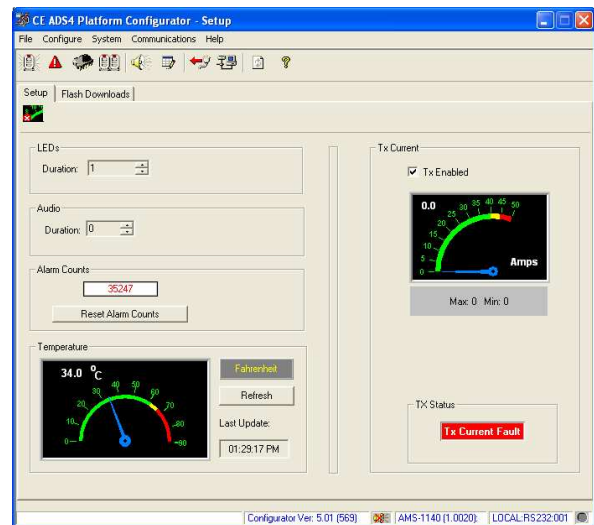

You can make the following adjustments to modify the system for a customer:

- Modify how long the LEDs flash and the audio alarm sounds
- Enable the system to work with Active Tags, which is a battery-powered tag that emits its own alarm

- Enable (or disable) the Tags Too Close feature so the pedestals silently alarm when a tag is left nearby
- Enable (or disable) the reduction of the size of the detection field behind the pedestals

You can use the configurator to find out the following information to troubleshoot problems:

- How many times the system has alarmed
- The temperature of the air around the main circuit board
- The current in the transmitter coils
- The status of the transmitter
- The amount of electronic noise the antenna sees and the strength of a tag signal
- The frequency of the tag signal
- A report of past and current system errors and runtime information

You can use the configurator to make the following changes to the detector:

- Download software upgrades into the detector
- Disable the transmitter temporarily to check for the source of false alarms
- Modify the Energy Trim level to decrease the impact of electronic noise from nearby anti-theft systems
- Adjust some operating parameters (Polarity, Minimum Threshold, Sensitivity, and the Nulling Pot) to reduce the effect of electronic noise the antenna receives from the environment
- Enable (or disable) the Phase Lock Loop feature to adjust for noise on the power line
- Change how the system synchronizes to the power line

Note: Refer to the online help provided with the configurator for a complete description of configurator operation.

Connecting to AC Power



WARNING: RISK OF ELECTRIC SHOCK! Make sure the primary pedestal is disconnected from its power source before you proceed.

1. Set the voltage selection jumper (J1) on the lower right side of the main circuit board to the proper setting. Refer to Figure 1 for the location of the jumper. The default setting is for 240Vac (no jumper). For 120Vac operation, install the jumper in J1. The jumper is in the pedestal installation kit.



CAUTION: If you install the jumper for 120Vac and connect the pedestal to a 240Vac supply, the system will be damaged.

If you set a pedestal to 240Vac and connect it to 120Vac power, the system will not operate properly. Also, the system will generate a low current error condition message (error number 21) that can be read with the service configurator software.

2. Remove the cover from the exit side of the primary pedestal. To do this: loosen the four fasteners at the base of the cover, and then lift the bottom of the cover up and then off the base.

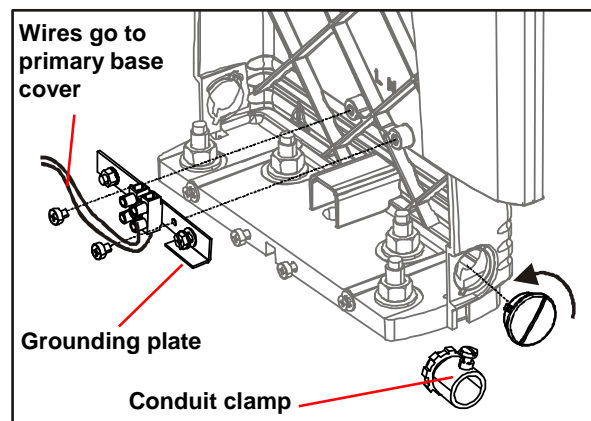

3. Use two screws from the alarm lens installation kit to attach the grounding plate to the primary pedestal. Do not unplug the cable from the main circuit board on the base.

4. Install the hole plug supplied in the pedestal installation kit in the conduit access hole that will not be used.
5. Install the steel conduit clamp supplied in the pedestal installation kit.

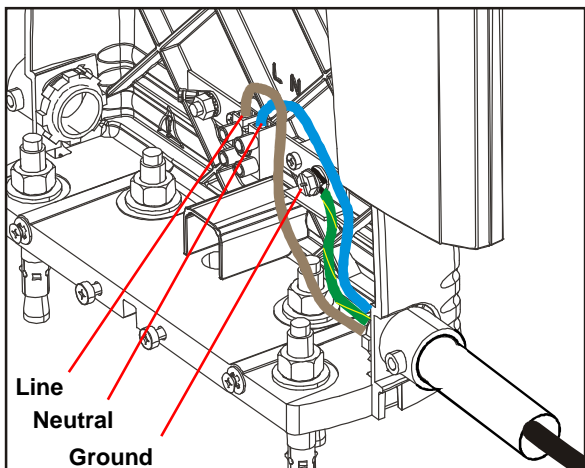

WARNING! DO NOT run the power cable and the Interconnect cable in the same conduit or raceway.

6. Have a licensed electrician wire the primary pedestal to power. The locations of where the Line, Neutral, and Ground wires connect to the grounding plate are shown above.

Tuning the Pedestals

Tuning the pedestals is not a standard part of initial installation; the system should be left at the factory default setting of minimum capacitance (all jumpers out). If the pedestals are placed near a lot of metal, however, the current in the system may be reduced and the performance can be reduced. If the performance is unacceptable and the maximum burst current is not at least 30A, you can use the following procedure to optimize the tuning until maximum peak current is achieved.

1. Remove the base covers on both pedestals and locate the tuning jumpers on the main circuit board on the primary pedestal and the secondary capacitor board. See Figure 1.
 - Primary tuning jumpers: J2, J3, J4
 - Secondary tuning jumpers: J1, J2
2. Ensure the tuning jumpers are set to their default values. See **Table 1** (primary) or **Table 2** (secondary).

3. Adjust the tuning jumpers on the primary pedestal up one step (for example, from Step 0 to Step 1).
4. Check the current.
 - If the current is less than before you adjust the capacitance, you are detuning the pedestal. Return to the default setting. You are done.
 - If the current goes up, you are tuning the pedestal in the correct direction. Keep adding capacitance until you find the peak current.
5. If you get to step 8 in **Table 1** (all jumpers in) and the current is still increasing, go to the secondary pedestal and increase the capacitance one step. Then go back to the primary pedestal, set it back to step one (all jumpers removed) and start adding capacitance on the primary one step at a time.

Table 1. AMS-1140 Tuning Table (Primary)

Step #	J4	JW3	JW2
1*	0	0	0
2	0	0	1
3	0	1	0
4	0	1	1
5	1	0	0
6	1	0	1
7	1	1	0
8	1	1	1

* Default

Table 2. AMS-1140 Tuning Table (Secondary)

Step #	J2	J1
1*	0	0
2	0	1
3	1	0
4	1	1

* Default

Troubleshooting

Checking Detector Operation



DO NOT perform the following procedure until you have thoroughly reviewed configurator software settings.

1. Verify all boards are properly seated and all cables are securely plugged in.
2. Turn on the circuit breaker.
3. Connect the laptop computer to J5 on the main circuit board and load the configurator.
Note: After power is applied the detector passes its power-up test, the power on/heartbeat LED (DS2) should start flashing once per second. If it does not flash, check for an error condition using either the laptop computer or by observing LED DS5 on the board. Refer to Figure 5 for the location of DS2 and DS5. Refer to the section entitled "Understanding Error Codes" on page 11 for interpretation of the codes.
4. Close the base cover and verify the transmit current is at least 25A. If it is less than 25A, go to the section "Tuning the Pedestal" on page 9.
5. Check the following:
 - If validations occur with no tags/labels nearby, increase the Minimum Threshold or change the Sensitivity in 1dB increments until validations cease.
 - If this Ultra•Max detector is causing another to constantly alarm or not detect, or vice versa, check the System Noise Average screen. If the bar meters are constantly reaching the maximum values, then adjust the Zero Crossing Delay.
 - Check the vicinity for tags or labels.
 - If a lot of noise is entering the detector but it is lower when the Polarity of the detector is set to "Figure-8" than when it is set to Aiding, set the Polarity to "Figure-8".
 - Set audio and LED durations.
6. Disconnect the laptop cable. Detector operation has now been verified.

Dead system/Low sensitivity

A detector that is dead or has low sensitivity may be without power, in the wrong mode, or affected by noise from an electronic device such as a TV set or PC monitor, or from certain fluorescent, halogen, or neon lamps. To diagnose the problem, you use the Mode LED (DS2) inside the primary base cover. Refer to Figure 6 for the location of DS2.

1. Observe the Mode LED (DS2). In what state is the lamp?
 - Off - No power
 - Steady (not flashing) – Service Mode
 - Flashing twice a second – Hidden Tag Mode
 - Flashing once a second – Normal Mode
2. Use the following table to determine the problem/action to take.

Status	Problem/Action
Off	The detector has no power. <ol style="list-style-type: none">1. Ensure the detector is connected to the AC power source.2. Check the circuit breaker in the store's breaker box. If the breaker tripped, reset it and check system performance. If the breaker will not stay on, call maintenance. If the breaker is OK, the detector needs service. Call for assistance.
Flashing twice per second	Detector is in Hidden Tag Mode. <ol style="list-style-type: none">1. Wait 30 seconds for the detector to revert to Normal Mode.2. Use a tag to test the system for sensitivity. If the detector still has low sensitivity, see "Flashing once per second" below.
On steady (not flashing)	Detector is in Service Mode. <ol style="list-style-type: none">1. To change detector to normal mode, insert a paper clip into the Tx-inhibit pushbutton access hole (Figure 3) and press the switch once.2. Test the detector for sensitivity with the tag/label. If the detector still has low sensitivity, see "Flashing once per second" below.
Flashing once	An electronic device or a lamp may be causing interference. One at a

per second time, turn off each device or lamp within 3m (10ft) of the pedestals and use a tag to test sensitivity. If sensitivity improves when a device is turned off, that is the interference source. Leave the device off or move it away from the receiver antennas. If sensitivity does not improve, call for assistance.

False Alarms

Nearby electronic devices or hidden tags/labels can cause the detector to false alarm.

1. To help diagnose the problem, the detector has a Mode LED DS2 (Figure 5). In what state is the lamp?
 - Flashing once a second – Normal Mode
 - Steady (not flashing) – Service Mode
 - Flashing twice a second – Hidden Tag Mode
2. Does pedestal alarm constantly or just sometimes—twice a minute or less?
 - Sometimes. Go to step 3.
 - Constantly. Go to step 4.
3. Move all store products 3m (10ft) from pedestal. Do alarms stop?
 - Yes. One or more moved products have a tag/label. Find and remove it, you are done.
 - No. Look for tags/labels within 3m (10ft) of pedestals. If no tags/labels are found and problem persists, go to step 6.
4. Place the alarming pedestal in Hidden Tag Mode by inserting the end of a paper clip into the Tx-inhibit access hole (Figure 3) and pressing the switch once. The pedestal should emit a three second tone and enter Hidden Tag Mode and the mode LED DS2 should flash rapidly. (If not, this feature has been disabled. Go back to step 3.) After 30 seconds, Hidden Tag Mode reverts to Normal Mode.

Do alarms occur during the 30 seconds Hidden Tag Mode is on?

 - No. Go to step 5.
 - Yes. Go to step 6.
5. After the Hidden Tag Mode completes, do alarms resume?
 - Yes. One or more tags/labels are still in the area. Find and remove them, you are done.
 - No. Ensure you waited 30 seconds and then check mode light to ensure pedestal is

not in Service Mode. If it is in Service Mode, press the mode switch once more to return to Normal Mode and go back to step 1. If it is not in Service Mode, wait until the system false alarms again before performing this procedure.

6. A nearby device such as a TV set or computer, or a neon or halogen lamp may be causing false alarms. One at a time, turn off each device or lamp within 3m (10ft). Do alarms stop when the device or lamp is off?
 - Yes. That device or lamp is the source of the false alarms. Leave the device or lamp off or move it away from the receiver antennas. If you cannot, see “No” below.
 - No. Call for assistance. Place the pedestal in Service Mode to stop the alarm until service arrives by inserting the end of a paper clip into the Tx-inhibit switch access hole (Figure 3). If the pedestal is in the Normal Mode, press the mode switch twice; otherwise, press the mode switch once. The mode LED should stay on continuously.

Understanding Error Codes

When the system encounters an error, it generates one of two types of error codes:

- **Recoverable** – these errors are not as serious as fatal errors. The system continues to transmit but an error code is stored in a log in RAM memory. If the system shuts down, the error codes will be lost.
- **Fatal** – this type of error is more serious than the recoverable errors. The system stops transmitting, displays the error three times on the system error LED (DS5), and logs the error code in a log in non-volatile memory (NVM). The system usually tries to reset itself but it may be unsuccessful.

The list of error codes is shown in Table 3. These codes are displayed on the System Error LED (DS5). A history of the errors can viewed using the configurator.

Interpreting LED Indicators

LED indicators on the receiver board can be used for diagnostic purposes. During the power-on self-test, all LEDs flash simultaneously to test their function, then they light in sequence to indicate the progress of the power on self-test. Figure 5 shows the location of the status LEDs.

Figure 5. LED locations



- DS1 (red) is the alarm indicator.
- DS2 (green) is the mode/power/heartbeat indicator, which shows that the board is powered and what mode the system is in (Normal/Hidden Tag/Service).
- DS3 (red) is the frequency rejection indicator. If this LED is lit, the pedestal has detected an out-of-frequency label, such as a deactivated or wounded label, in the vicinity.
- DS4 (red) is unused.
- DS5 (yellow) is the validation/system error indicator. This LED flashes in a coded sequence whenever the board fails the power on self test, or run-time diagnostic tests, or when a serious failure interrupt occurs. To indicate an error code, the DS5 error LED on the receiver board will flash a number of times, pause, then flash again a number of times. For example: DS5 flashing three times, pausing, then flashing two times indicates error code 32. Error codes are listed in Table 3.
- DS6 (green) indicates that data is being received on the Network RS-485 port.
- DS7 (red) indicates that data is being transmitted on the Network RS-485 port.

Table 3. AMS-1140 error codes

Alert Code		Action
11	Illegal Instruction	Not applicable
12	Unimplemented Interrupt	Not applicable
13	NVM Write Failed	Fatal error. Replace main circuit board
14	Invalid Device	Fatal error. Replace main circuit board
15	Sequence Table Error	Not applicable
16	Out of Memory	Not applicable
17	Undecided: No Split	Not applicable
18	Watchdog: Task Reset	Recoverable. First, try resetting the NVM to its defaults. If problem persists, reinstall application software. If problem persists, replace main circuit board.
21	Current Sense Antenna A	Recoverable. Retune antennas
22	Current Sense Antenna B	Not applicable
23	Power Supply Overtemp Fault	Recoverable. Replace main circuit board.
24	Transmitter Failsafe Fault, Burst Too Long	Recoverable. Replace main circuit board.
25	Receiver samples exceeded the Receiver buffer	Recoverable. Reinstall application software
26	TX PWM Fault	Fatal error. Check for large amounts of metal in vicinity of the pedestals. If this is not the cause and error keeps occurring, replace the main circuit board.
27	HW Current Fault	Fatal error. If the error keeps occurring, replace the main circuit board.
28	Tx Shutdown	Not used.
29	SW Current Fault	Fatal error. This error is caused by an over-current condition. This is probably caused by hardware. This could be caused by a damaged main circuit board or a short in the coil wiring, for example.
31	Missing Zero Crossing Signal	Recoverable. Check the AC line quality. If it is OK, replace the main circuit board.
32	Missing External Zero Crossing Signal	Recoverable. This occurs when Universal Sync has been selected as the Sync source in the configurator but no signal is received. Check the connection on the RS-485 connectors on the receiver board and the signal source.
33	Invalid Line Frequency at Power/Up	Recoverable. This can be caused by noise on the AC power line. Check the AC line quality.
34	Invalid Power Supply Type at Powerup	Not applicable
35	Wired Sync: Missing Signal	Not applicable
36	Unknown Voltage ID selection assuming 58kHz	Fatal. Replace main circuit board.
37	Line PLL Unlocked	Recoverable. This can be caused by noise on the AC power line. Check

		the AC line quality.
41	Jammer Event Detected	Not applicable
44	Host Communication Mailbox Full	Recoverable. Reload the application software. If error is not eliminated, replace the main circuit board.
45	LDM Power Save Active	Not applicable
46	LDM Power Save Inactive	Not applicable
51	No Reference	Not applicable
52	Invalid Alarm Type from detector	Not applicable
53	NVM Checksum Error	Recoverable.
54	NVM Reset	Recoverable.
55	NVM Revision Change	Recoverable.
56	People Counter Blocked Sensor Detected	Not applicable
57	Invalid Wired Sync Command Received	Not applicable.

Specifications

Power Supply

Primary Input 100-120Vac
or 200-240Vac @ 50-60Hz

Primary power fuse One 2A, 250V,
slo-blo, hi-breaking,
5mmx20mm fuse

Current draw less than 0.5Arms @ 120Vac

Input power less than 44W

Transmitter

Operating frequency 58kHz (± 200 Hz)

Transmit Burst Duration 1.6ms

Transmit Current (in Tx coil) 42A peak

Transmit Current (in Interconnect cable) .. 17A peak

Burst Repetition Rate:

Based on 50Hz ac 37.5Hz

Based on 60Hz ac 45Hz

Antenna Coil Resistance 25 ohms ($\pm 5\%$)

Receiver

Center Frequency 58kHz

Alarm

Audio level 83dBA

Environmental

Ambient Temperature .. 0°C to 40°C (32°F to 104°F)

Relative Humidity 0 to 90% non-condensing

Enclosure IPx0

Mechanical

Height 137.1cm (54in)

Width 35.8cm (14in)

Depth (base) 8.6cm (3.4in)

Declarations

Regulatory Compliance



EMC 47 CFR, Part 15
EN 300 330
EN 301 489
RSS 210

Safety UL 60950-1
CSA C22.2.60950-1
EN 60950-1

REGULATORY PRODUCT NAME:

ZA1140-D = TYPE: AMS-1140

FCC ID: BVCAMS1140

FCC COMPLIANCE: This equipment complies with Part 15 of the FCC rules for intentional radiators and Class A digital devices when installed and used in accordance with the instruction manual.

Following these rules provides reasonable protection against harmful interference from equipment operated in a commercial area. This equipment should not be installed in a residential area as it can radiate radio frequency energy that could interfere with radio communications, a situation the user would have to fix at their own expense.

EQUIPMENT MODIFICATION CAUTION: Equipment changes or modifications not expressly approved by Sensormatic Electronics Corporation, the party responsible for FCC compliance, could void the user's authority to operate the equipment and could create a hazardous condition.

Other Declarations

WARRANTY DISCLAIMER:

Sensormatic Electronics Corporation makes no representation or warranty with respect to the contents hereof and specifically disclaims any implied warranties of merchantability or fitness for any particular purpose. Further, Sensormatic Electronics Corporation reserves the right to revise this publication and make changes from time to time in the content hereof without obligation of Sensormatic Electronics Corporation to notify any person of such revision or changes.

LIMITED RIGHTS NOTICE: For units of the Department of Defense, all documentation and manuals were developed at private expense and no part of it was developed using Government Funds. The restrictions governing the use and disclosure of technical data marked with this legend are set forth in the definition of "limited rights" in paragraph (a) (15) of the clause of DFARS 252.227.7013. Unpublished - rights reserved under the Copyright Laws of the United States.

TRADEMARK NOTICE: *Ultra•Max* and *Sensormatic* are registered trademarks of Sensormatic Electronics Corporation. Other product names (if any) mentioned herein may be trademarks or registered trademarks of other companies.

No part of this guide may be reproduced in any form without written permission from Sensormatic Electronics Corporation.

RWH 01/2010