

ZBAMB2010T Tabletop Deactivator

Installation Guide

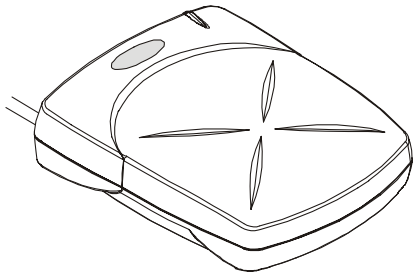

The AMB-2010 tabletop deactivator consists of the deactivator unit and a class 2 external power supply that plugs into an ac outlet. The power LED glows green when power is applied.

The deactivator deactivates UltraStrip II and III security labels rubbed and swirled on its surface. The deactivate field is 10cm (4 in.) square and 7.5cm (3 in.) high. Deactivation is indicated by the power LED pulsing orange and a long beep.



WARNING: Do not deactivate labels on audio or videotapes. The deactivate field is not magnetic media safe.

The deactivator is intended to be installed “as is” without adjustments. If adjustments are necessary, a laptop computer containing special configuration software can be connected to a jack at the rear of the deactivator.

Please observe the following safeguards before you begin installation.



WARNING: Hazardous areas.

DO NOT install the deactivator where highly combustible or explosive products are stored or used.



WARNING: RISK OF ELECTRIC SHOCK!

Deactivator has no user-serviceable parts! DO NOT attempt to open the deactivator.

Power Cord. The cord cannot interfere with the operation of cash drawers, conveyor belts, or with the operation, maintenance or removal of equipment.

If you need assistance...

Call 1-800-241-6678
(Sensormatic / ADT Customer Response Center).

Cleaning the Deactivator

Clean exterior surface using a soft cloth moistened with warm, soapy water. Dry thoroughly. DO NOT use solvents or scouring cleanser.

Deactivation Status Indications

Status	LED	Tone
Power On Sequence	Flashing Green (for 10 seconds)	Short Beep
Ready	Green	
Deactivate	Pulsing Orange	Long Beep
Transmit Off	Flashing Green	
Fault Condition	Red	
Hard Tag Present		Continuous Short Beep

Install Kit Required

Install Kit 0352-0101-01

Deactivator Assy.	1	0303-0038-01
Template, Cutout	1	8000-2699-02
Velcro, Hook, w/Adhesive	.5ft	3200-0358-01
Velcro, Loop, w/Adhesive	.5ft	3200-0358-02
Cable Tie, 5-1/2"L x 16"W, Nylon	3	6009-0001
Mount, Adhesive Backed, 1-1/8 sq.	3	6009-0003
Clamp, Cable, Nylon, .313D, .172MTG	2	6010-0035-10
Screw, Self-Tapping, 3.5x16 PHP	2	5810-3051-120
Label, Keep Magnetic Media Away	1	2402-1301-01
Pad, Alcohol	2	1600-0033

Tools Required

- Power drill and drill bits
- Phillips screwdriver
- Hand vacuum and broom.

Proper Placement

- DO NOT install the deactivator over a metal surface. Deactivator fields interact with metal causing deactivator performance to degrade.
- The field from the deactivator can interact with certain POS equipment. Avoid placing the deactivator too close to POS equipment.

Installation

Positioning the deactivator so the LED window faces away from the sales associate:

1. Mount the deactivator to the countertop.

Using a ZPCM mounting bracket (optional):

See instructions supplied with bracket.

Using hook and loop material:

- a. Mate hook and loop material, then cut hook and loop material into two strips.
- b. Remove the liner from the hook side of each strip, then fasten a strip to the flat area on the bottom front and rear edges of the deactivator.
- c. Place the deactivator in the desired location and press down.

Using M5 machine screws:

- a. Place the template supplied in the desired mounting location and use it to drill four holes for M5 machine screws.
- b. Select the appropriate length for the screws. Screw length should be 8mm (.31 in.) plus the counter thickness.
- c. From the underside of the countertop, insert the four machine screws, mate them with the mounting holes in the bottom of the deactivator, and tighten from below.

2. Secure the power cable.

Using cable ties (not shown):

- a. Remove the liner from the adhesive-backed mount and run a tie through the hole in the mount and around the cable.
- b. Fasten the cable tie securely around the cable and remove excess.

Using the cable clamp:

- a. Place the clamp around the cable near the antenna.
- b. Secure the clamp in place using a screw.

3. Connect the deactivator to the power supply and plug the power supply into an ac outlet. The deactivator will produce a brief tone at power up.

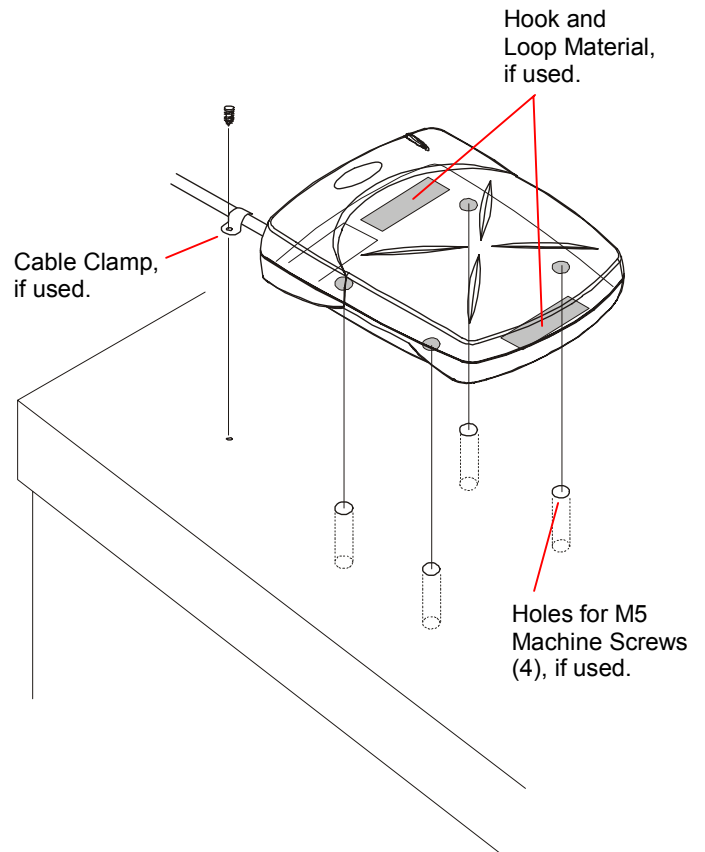

Optional Adjustments

To be determined.

Specifications

Power Supply

Input voltage 100–240 Vac, 50/60 Hz

AC line current 1 Arms (max.)

Deactivator

Input voltage 18 Vdc

Auto synchronization Optional

Tone volume Adjustable, Off

Operating temperature 0° to 40°C

Humidity 0 to 90% non-condensing

Weight (deactivator) 0.95kg (2.1 lbs)

Weight (power supply) 0.28kg (0.6 lbs)

Declarations

Regulatory Compliance

EMC	47 CFR Part 15 RSS 210 EN 300330 EN 301489
EMF	VDE 0848
Safety	UL60950 EN 60 950 CE Mark

FCC COMPLIANCE: This equipment complies with Part 15 of the FCC rules for intentional radiators and Class A digital devices when installed and used in accordance with the instruction manual. Following these rules provides reasonable protection against harmful interference from equipment operated in a commercial area. This equipment should not be installed in a residential area as it can radiate radio frequency energy that could interfere with radio communications, a situation the user would have to fix at their own expense.

EQUIPMENT MODIFICATION CAUTION: Equipment changes or modifications not expressly approved by Sensormatic Electronics Corporation, the party responsible for FCC compliance, could void the user's authority to operate the equipment and could create a hazardous condition.

Other Declarations

WARRANTY DISCLAIMER: Sensormatic Electronics Corporation makes no representation or warranty with respect to the contents hereof and specifically disclaims any implied warranties of merchantability or fitness for any particular purpose. Further, Sensormatic Electronics Corporation reserves the right to revise this publication and make changes from time to time in the content hereof without obligation of Sensormatic Electronics Corporation to notify any person of such revision or changes.

LIMITED RIGHTS NOTICE: For units of the Department of Defense, all documentation and manuals were developed at private expense and no part of it was developed using Government Funds. The restrictions governing the use and disclosure of technical data marked with this legend are set forth in the definition of "limited rights" in paragraph (a) (15) of the clause of DFARS 252.227.7013. Unpublished - rights reserved under the Copyright Laws of the United States.

TRADEMARK NOTICE: Sensormatic, and the Sensormatic logo are trademarks or registered trademarks of Sensormatic Electronics Corporation. Other product names mentioned herein may be trademarks or registered trademarks of Sensormatic or other companies.

No part of this guide may be reproduced in any form without written permission from Sensormatic Electronics Corporation.

MDR 11/02