

AMS-3000 Antenna with Digital 216 Controller

Installation Guide

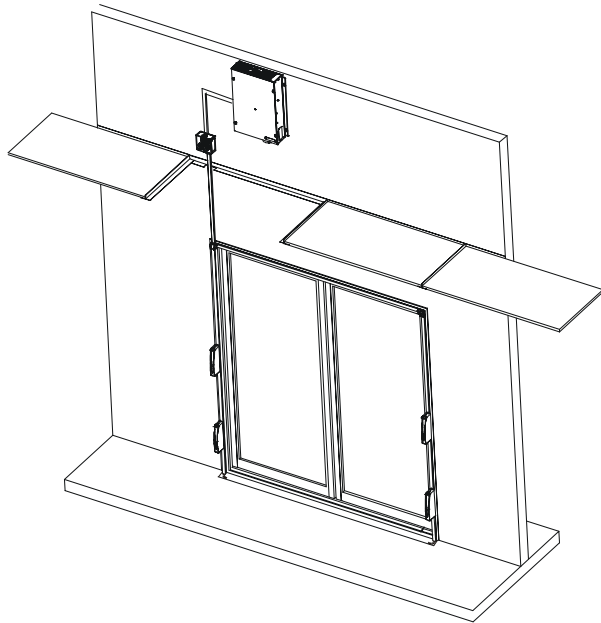

ZSLOOP

Contents

About this Guide	1
About the Product	1
Installation Requirements	2
Tools and Equipment Required	3
Installation	3
Planning the installation	3
Installing the controller	4
Installing the equipment in the floor	4
Preparing the extrusions	6
Mounting extrusions	9
Installing the cap box	9
Connect antenna and receiver wires to controller	10
Connecting the remote alarm	10
Configuring, tuning, and testing	10
Declarations	12
Regulatory Compliance	12
Other Declarations	12

About this Guide

This installation guide explains how to install the antennas and capacitor box for AMS-3000 systems that use a Digital 216 controller. Other related documents are:

- Planning Guide, 8200-0179-01
- Installation Guide, AMS-3000 Antenna with Ultra*Post Plus Controller, 8200-0179-03

Note: Because customer requirements dictate the placement of system components, your Sensormatic representative will supply this information separately.

About the Product

The AMS-3000 system consists of an antenna cable, three metal extrusions to house the cable, a capacitor (cap) box, various connecting hardware, and a set of receiver antennas.

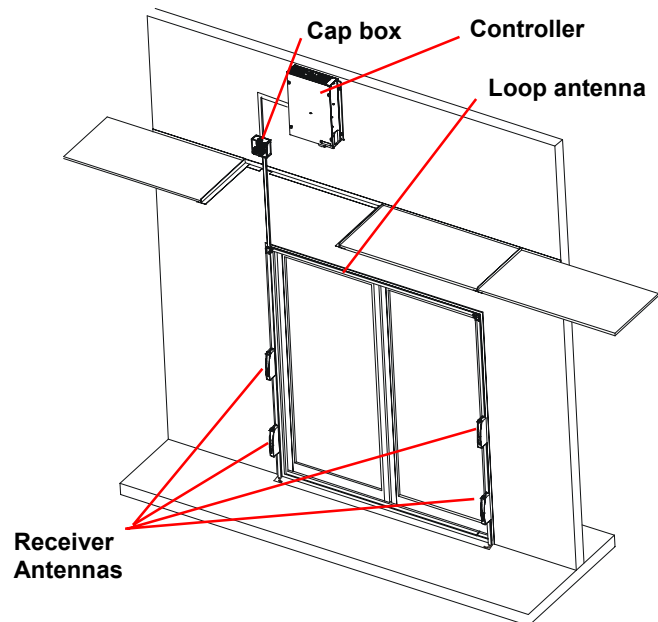

Installation Requirements

Verifying Equipment and Unpacking

- ❑ Verify that all equipment has arrived. Make sure the system configuration is the right one for the installation site.
- ❑ Unpack major components in a back room. At the install site, lay out parts in the order you will need them. Do not clutter the aisle or cause a trip hazard.

Note: The capacitor board is in a cardboard sleeve taped to the bottom of the cardboard antenna sleeve. The PVC leveling legs are inside an envelope with the antenna.

Installer/Contractor

- ❑ **Shall have electrical work comply with the latest national electrical code, national fire code, and all applicable local codes and ordinances.**
- ❑ Shall coordinate all work with other trades to avoid interference.
- ❑ Shall verify existing site conditions and coordinate with the owner's representative and appropriate utilities as required.
- ❑ Shall obtain copies of all related plans, specifications, shop drawings and addenda to schedule and coordinate related work.
- ❑ Shall thoroughly review the project to ensure that all work meets or exceeds the above requirements. Any alleged discrepancies shall be brought to the attention of Sensormatic Electronics.



WARNING!

Do not install this product in hazardous areas where highly combustible or explosive products are stored or used.



WARNING—RISK OF ELECTRIC SHOCK!

If the equipment must be left unattended during installation, turn off the power or cover high voltage components so that no unauthorized person has access to hazardous voltages.

Antenna Placement and Cabling

- ❑ Whenever possible, keep the antennas at least 2.4m (8') away from noise sources such as computer monitors, TVs, switching power supplies, and neon displays.

- ❑ Maximum cable distance from the AMS-3000 antenna to the capacitor board enclosure is 1.2m (4'). DO NOT splice antenna cables.
- ❑ Maximum cable distance from the controller to the cap board enclosure is 12m (40')
- ❑ Maximum cable distance from the receiver antennas to the controller is 12m (40')



WARNING!

DO NOT compromise the structural integrity of the floor by cutting or removing rebar. Contractors must obtain approval for all proposed structural changes. All structural changes must meet national and local requirements.

CAUTION: To avoid adding significant time and cost to the in-floor installation, check detector performance and label detection height at the exact installation site. Do this BEFORE pouring the concrete.

- ❑ **All electrical work must comply with the latest national electrical code, national fire code, and all applicable local codes and ordinances.**
- ❑ High strength, non-metallic, non-shrink mortar/concrete with a compressive strength of 5000 psi is required. (For example, FX-228 mortar mix and FX-752 bonding agent by Fox Industries).
- ❑ Mortar cure time depends on the mix and temperature of the mortar ingredients.
- ❑ Avoid walking on antenna cables during installation.
- ❑ Heavy forklifts can pass over the mortar after 24 hours, provided the mortar is protected by 1.9cm (3/4") steel plates.
- ❑ Have on hand tools and equipment necessary to place the mortar once it is mixed.

Cap Board Box

- ❑ Mount the cap board box as close to the controller as possible. Maximum distance from the controller to the cap box is 12m (40')
- ❑ If conduit is not used for the cables between the cap box and controller, use Romex connectors wherever cables enter the controller and capacitor board enclosure.

Tools and Equipment Required

For all system installations:

- Plastic sheeting at least 0.15mm (6-mil) thick (to protect nearby items from dust)
- Chalk or red permanent marker
- Floor saw
- PVC pipe cutter or hacksaw
- Hammer drill with 6.5mm (1/4") and 9.6mm (3/8") masonry drill bits
- Power drill with 1.6mm (1/16"), 6.5mm (1/4"), and 9.6mm (3/8") drill bits
- Hammer
- Phillips and slotted screwdrivers
- 14-16 AWG and 16-22 AWG wire strippers
- Ratchet and socket set
- Vacuum and broom
- Wet vacuum
- Level
- Electrical tape
- Teflon pipe tape
- Caution tape
- Duct tape
- Clear lacquer spray

Installation

To install the AMS-3000 antenna, perform the following steps.

- I. Plan the installation.
- II. Perform a "tape up" to ensure system can be installed.
- III. Install the controller.
- IV. Dig trench, install floor conduit, and feed wires.
- V. Prepare extrusions (drill holes, cut extrusions, feed wires, and attach Rangers).
- VI. Attach extrusions and corner pieces
- VII. Mount cap box, 1x1 channel (if necessary), and route wires.
- VIII. Connect antenna and receiver wires to power pack and cap box.
- IX. Mount remote alarm and connect.
- X. Configure, tune, and test.

Planning the installation

Plan the placement of the controller, cap box, receivers (Rangers), and the loop. See Planning Guide for all details.

Controller restraints

- Determine whether the controller can be visible to customers. If it must be hidden it can go above a drop ceiling or in another room.
- Ensure the ranger cables will be long enough to reach the controller.
- Ensure the transmitter (loop) cables will be long enough to reach the controller.
- If you have multiple loops near each other, resolve all antenna issues: one pack or two, placement of controller to reach both antennas.
- Ensure the controller will be near a power outlet.

Cap box restraints

- Determine whether the cap box will go above the antenna or off to the side near the floor.
- Determine if the cap box can be visible or must be hidden. If it must be hidden it can either go above a drop ceiling or be mounted in a wall off to the side of the antenna.
- Locate a suitable mounting surface (stud location, grout lines).
- Ensure the cap box is within 1.2m(4ft) of the loop.

Ranger restraints

- Ensure that the height of rangers does not obstruct the operation of the door.

Loop restraints

- Determine whether the extrusions will go on the store side of the doorframe or within the arch of the doorframe.
- The only allowable configuration for the loop antenna is an "L" shape, so ensure the antenna can be routed in the floor in this way.
- Measure the height and width of the doorframe to determine extrusion lengths.
- Keep loops on separate packs several feet apart.

- The dimensions of the exit door affect the maximum amount of current in the loop and the strength of the field it will generate. In general, a smaller door can generate a stronger B-field without exceeding regulatory limits. Because larger door openings require a stronger field to maintain pick ratios, you must determine if the loop will work adequately for an installation. Use the table below to determine if the field strength will be sufficient to give you the pick rate you need for the exit. You may need to tape up an antenna before installing the extrusions to help predict detector performance.

Loop Size		Maximum Allowed Field Strength
Width	Height	
5.5ft	9ft	12.9 A/m
6ft	8ft	13.1 A/m
5ft	8ft	17.6 A/m
3ft	8ft	17.9 A/m
6ft	7ft	14.6 A/m

Installing the controller

Refer to the appropriate controller installation manual for instructions on installing the controller.

Performing a tape-up

It may be necessary to tape the antenna cable around the door in the intended configuration prior to installation to check for performance issues. This is especially true for installations requiring a large antenna loops or with metal doorframes. You should tape the antenna cable in the intended configuration, connect it to the controller, and then check the current or field strength.

Installing the conduit in the floor

The loop cable is installed beneath the surface of the floor in 1/2" conduit. Note that 1/2" conduit measures 2.13cm (.84") in outside diameter.

- If the doorframe and threshold are metal and have no gap, remove the threshold and cut 6mm from the length of the threshold with a saw.
- Ensure there are no brackets underneath that make contact to the threshold and the side

frames. If contact is made, make sure to isolate such contacts.

- Prepare the bottom run of loop cable. The route of the cable depends on where the cap box will be located and whether the antenna goes on the store side of the doorframe or the inside the arch of the doorframe.
 - If the cap box will be above the door and the antenna goes on the store side of the doorframe**, assemble the floor conduit and trace an outline on the floor as shown below. Use a floor saw and chisel to cut the 32mm (1.25") deep trench in the floor that is wide enough to accept 1/2" conduit. Note that (1/2") conduit measures 2.13cm (.84") in outside diameter.

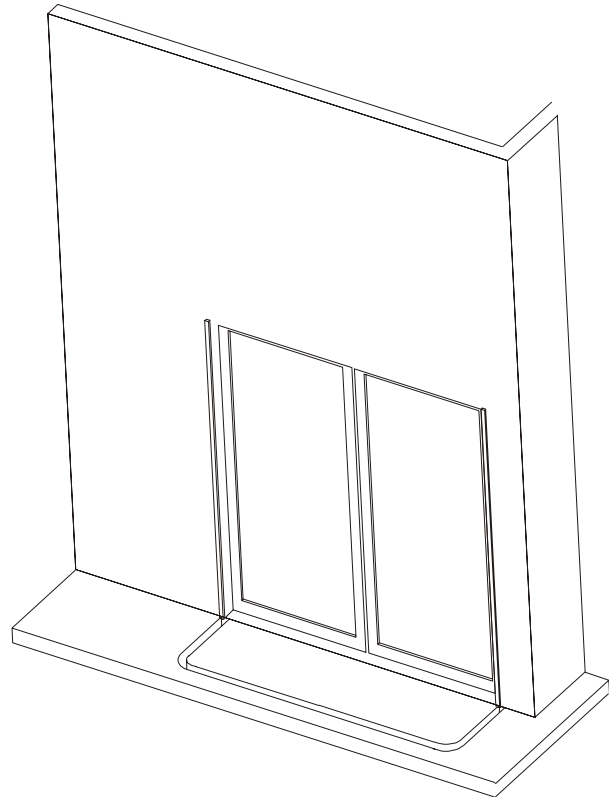

- **If the cap box will be above the door and the antenna goes inside the archway of the doorframe**, assemble the floor conduit and trace an outline on the floor as shown below. Use a floor saw and chisel to cut the 32mm (1.25") deep trench in the floor that is wide enough to accept 1/2" conduit. Note that (1/2") conduit measures 2.13cm (.84") in outside diameter.

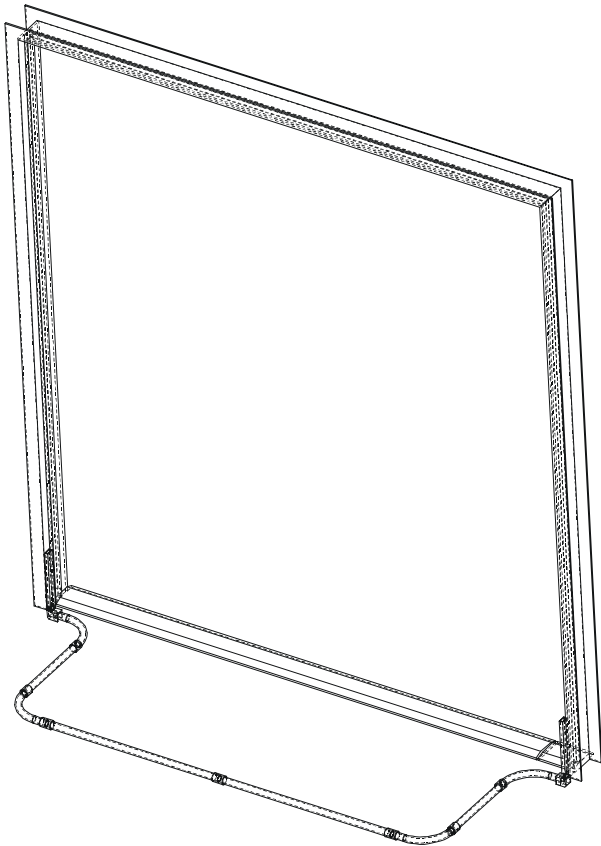

- **If the cap box will be installed near the floor**, the trenching pattern is different. Assemble the floor conduit, including the section that routes the cable off to the side. Trace an outline of the conduit on the floor. Use a floor saw and chisel to cut the 31mm (1.25") deep trench in the floor that is wide enough to accept 1/2" conduit. Note that 1/2" conduit measures 2.13cm (.84") in outside diameter. See the picture below for an example of what the trench looks like for an installation with the cap box near the floor and the antenna mounted on the store side of the doorframe.



4. Reinstall the threshold if it was removed. Fill the gap with RTV. Put 1/2" conduit in the trenches.
5. Connect the conduit runs using the elbows provided.
6. Connect the 1/2" conduit-to-extrusion adapters to the ends of the conduit near the extrusions.
7. If the antenna will not be installed until a later date, insert a dummy wire into the conduit to facilitate antenna routing later. You should use Yellow 77 or a similar wire-pulling lubricant to ensure the wire can be pulled easily.

Preparing the extrusions

1. Determine on which edge the Rangers will line up: inside edge, outside edge, or on side of extrusion. Lining up on the inside edge of the doorframe is preferred. If a nearby wall or other object prevents this, line the Rangers up on the outside edge of the doorframe. Ensure that arrows on all the Rangers point in the up direction.



2. Measure length of vertical extrusion needed. Remember to allow for length necessary for insertion into corner piece in floor.
3. Cut extrusions to length. Make sure you cut the bottom of the extrusion, not the end with the

tape indicating hole locations. Score the tape before cutting.

4. To facilitate marking the extrusions for drilling, a label has been provided in the extrusion to show location and size of holes.
5. Prepare the right extrusion.

Note the two template labels at the bottom of the extrusions. Use a center punch and punch the center of the holes marked for the right side "R". Then drill through one surface with drill size that comes closest to the hole diameter on the template.

6. Prepare the left extrusion.

Same as right side, drill through holes marked for left side "L".

7. Prepare the top extrusion.

Cut the top extrusion to the proper length: the width of the door minus .5".

8. Install Rangers (ZKRANGER-2 only).

- a. Find 91cm (36") supplied wire in the kit. (The interconnect wire included with the kit is not long enough.)

- b. Run wire from lower ranger to upper ranger lower hole. Note that you may have to route wire through hole in Ranger to get to other side.

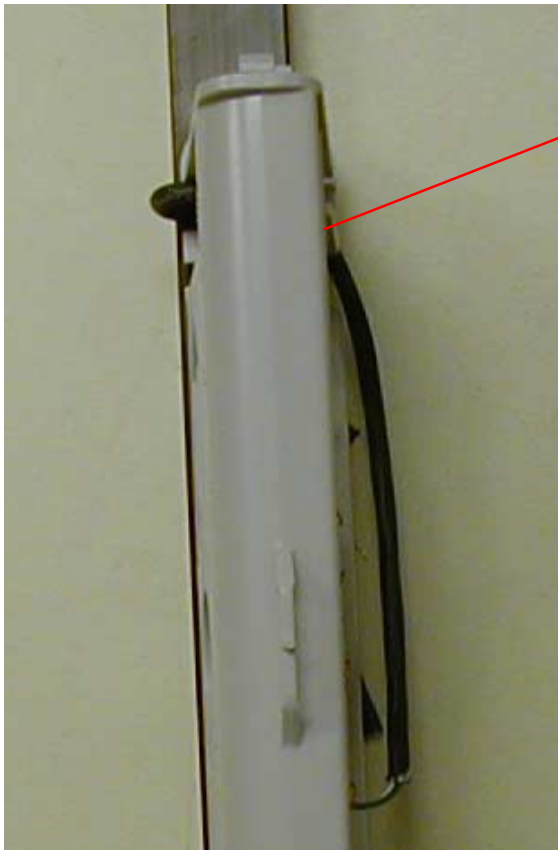

Wire
routed
through
Ranger

- h. Remove backing from adhesive, align Ranger to correct edge of extrusion, and stick Ranger to extrusions.



- c. Connect wires to bottom and top Ranger per instructions in kit. (Bottom four-wire connector on bottom to top two-wire connectors on top).
- d. Align notches for wires and edge of Ranger with edge of extrusion.
- e. Run wire from top of extrusion to top hole.
- f. Connect wires to top Ranger.
- g. Remove labels and using towelette, clean surface of extrusions.

- i. Drill two 2.0mm(3/32") holes through each Ranger at each of the smaller notches.



- j. Install two 8mm M4 screws through Ranger and into extrusion. Do not use screws in Ranger kit; they are too long.



- k. Repeat steps for Rangers on other extrusion. Note that notches for screws may not be available and you will need to drill hole in Ranger.
9. If the cap box will be installed above the door, route the loop cable through the conduit in the floor. Ensure that the adapter is in place at the ends of the conduit. Also note that the section of the loop cable coming out of the side nearest the cap box should be shorter than the section coming out the other side.
 10. Route the loop cable through the left extrusions.
 11. Put the covers on the Rangers at the very end.

Mounting extrusions

Extrusions can be mounted to painted steel, aluminum, wood, drywall, or glass surfaces.

1. Clean all surfaces where extrusions will go with towelette. Allow surfaces to dry.
2. Route the loop cable through the right extrusion.
3. Remove the backing from the adhesive tape.
4. Insert the bottom of the left extrusion into the corner piece and shove downward. If necessary, strike top of extrusion with hammer to ensure extrusion enters corner piece.
5. Press the extrusion against the doorframe.
6. Measure the width of the doorframe and cut the top extrusion to that length minus 13mm (.5").
7. If this is a wood or drywall doorframe drill a 6mm (1/4") hole through the extrusion for the screw. Use a 10mm (3/8") bit to drill through the front side of the extrusion for the screw head to fit through. If this is a drywall doorframe, drill a hole for a #10 anchor or molly and insert the anchor. Secure at the end with supplied wood screw. Note that the photo below shows the hole being drilled while the extrusion is on the floor.



8. Route the loop cable and Ranger wires through the top extrusion.
9. Use towelette to clean mating surface and position top extrusion.
10. Remove adhesive backing from top extrusion (including for wood and dry wall surfaces).
11. Press top extrusion against surface.
12. Remove the backing from the adhesive tape on the right extrusion
13. Insert the bottom of the left extrusion into the corner piece and shove downward. If necessary, strike top of extrusion with hammer to ensure extrusion enters corner piece.
14. Press the extrusion against the doorframe.
15. See the above steps for wood.

Installing the cap box

The cap box can be installed near the top of the door, above a suspended ceiling, or inside a wall next to the antenna. Antenna performance degrades as you move the cap box further away from the loop; the maximum separation distance is 4 feet.

1. Route the loop cable and receiver wires from the extrusions to the cap box.
 - a. Measure the length of 1"x1" channel you will need and cut the channel if necessary.
 - b. Cut a 1x1 square hole in the ceiling above the adapter piece on the top corner of the extrusion.
 - c. Feed the two ends of the loop cable and the receiver wires through the channel.
 - d. Put channel through hole in ceiling.
 - e. Check the alignment of the 1x1 channel and the antenna by attaching the adapter piece to the extrusions and inserting the 1x1 channel. Do not peel the adhesive backing on the adapter yet.
 - f. Peel the adhesive backing from the channel and attach the 1x1 channel to the wall.
 - g. Wipe the tops of the extrusions and channels with a towelette.
 - h. Attach the adapter to the top of the 1x 1 channel. Tighten the screw on the adapter to secure the channel.

- i. The adapter may be attached directly to the cap box or a short run of 3/4" conduit may be used between them. The total distance from the extrusion to the cap box may not exceed 1.2m (4 ft).
2. Install the cap box. The cap box is rated for installation above the ceiling. The cap box should be mounted directly above the corner piece or in the wall next to the antenna.
 - a. Orient cap box one orientation only to ensure screws go into stud and for ease of reading tuning jumpers.
 - b. Fit cap box onto the adapter and screw in fitting to hold cap box in place.
 - c. Mount the cap box to the wall using two screws. Cover any open holes.
 - d. Install the cap board in the cap box.
 - e. The receiver wires pass through the cap box but must be dressed in tie wraps along the sides of the cap box.
 3. Connect the loop cable to the cap box.

Pin	P1-P2
1	Black
2	Red
3	Green
4	White
5	Ground

Connect antenna and receiver wires to controller

The wires between the controller and the cap box are Class 2 and Class 3 signaling wires. This means they do not require conduit, but conduit or Wiremold may be used to dress the cables.

1. Run the transmitter cable from the cap box to the controller. Conduit may be used.
2. Connect the transmitter cable to the cap box.

Pin	P3
1	Black
2	Red
3	Ground

3. Connect the conduit (if used) from the cap box to the controller.



Connecting the remote alarm

The antenna requires either the remote alarm (ZC30) or the message unit (ZC35). Mount the remote alarm or message unit and connect it to the controller. Refer to the appropriate controller installation manual for information on mounting and connecting these devices.

Configuring, tuning, and testing

When you tune the antenna, the goal is to have the highest B field strength without exceeding the legal limit. The B field strength is decreased by the presence of metal (especially metal loops) in the vicinity of the antenna. To compensate for this loss, you can increase the field strength by increasing the current in the antenna. There are two ways to increase the current in the antenna; you can adjust the amount of capacitance on the cap board to bring the antenna closer to resonance or you can use the lap top configurator to change the output current. Depending on the configuration of the antenna and the environment, you may be able to resonate the antenna and be within the legal limits for the B-field or you may need to stop short of resonance to avoid going over the limit.

The tuning process depends on whether you have a B field meter.

- If you do not have a B field meter, you will need to look up your antenna size and configuration in the table below and then tune the capacitor board until you reach

the maximum allowable current in the antenna.

- If you have a B field meter, you will tune the capacitor board until the B field reaches its maximum allowable strength. Because this is a more direct measurement of the B field strength, you should be able to put more current through the antenna (and therefore get better pick) than using the table.

The procedure below describes how to tune the capacitor board.



WARNING: RISK OF ELECTRIC SHOCK! Cap box contains high voltage components. Avoid touching other components when moving the jumpers during tuning.

1. Turn on the controller.
Configure controller to proper transmit/receive mode for the AM Loop system
2. At the cap box, start the tuning procedure with all of the capacitors out of the circuit.
3. Tune the cap box by using either the B field meter or the configurator.
 - a. If you have a B field meter, follow the procedure below:
 - 1) Set the current level in the configurator to lowest setting.
 - 2) Make sure all jumpers in the capacitor board are in the “in” position.
 - 3) By removing jumpers, find combination that results in the maximum current as displayed in the configurator. The system is now tuned.
 - 4) Look at the B-field meter reading in the table below for the respective door size. Adjust the current in the configurator and/or re-tune the Cap PCB as necessary to arrive at the B-field meter reading required.
 - b. If you do not have a B field meter:
 - 1) Set the current level in the configurator to lowest setting.
 - 2) Make sure all jumpers in the capacitor board are in the “in” position.

- 3) By removing jumpers, find the combination that results in the maximum current as displayed in the configurator. The system is now tuned.
- 4) Find the loop size in the table below that most closely matches the size of your antenna and find out what is the maximum allowable current.
- 5) Adjust the current using the configurator and/or re-tune the Cap PCB to arrive at the maximum allowable current.

Loop Size		Maximum allowable current
Width	Height	
5.5ft	9ft	TBD
6ft	8ft	TBD
5ft	8ft	TBD
3ft	8ft	TBD
6ft	7ft	TBD

4. Test the system with a tag or label.

Declarations

Regulatory Compliance

Emissions	47 CFR, Part 15 RSS 210
Safety	UL1950 CSA C22.2 No 950 EN 60 950

FCC COMPLIANCE: This equipment complies with Part 15 of the FCC rules for intentional radiators and Class A digital devices when installed and used in accordance with the instruction manual. Following these rules provides reasonable protection against harmful interference from equipment operated in a commercial area. This equipment should not be installed in a residential area as it can radiate radio frequency energy that could interfere with radio communications, a situation the user would have to fix at their own expense.

EQUIPMENT MODIFICATION CAUTION: Equipment changes or modifications not expressly approved by Sensormatic Electronics Corporation, the party responsible for FCC compliance, could void the user's authority to operate the equipment and could create a hazardous condition.

Other Declarations

WARRANTY DISCLAIMER: Sensormatic Electronics Corporation makes no representation or warranty with respect to the contents hereof and specifically disclaims any implied warranties of merchantability or fitness for any particular purpose. Further, Sensormatic Electronics Corporation reserves the right to revise this publication and make changes from time to time in the content hereof without obligation of Sensormatic Electronics Corporation to notify any person of such revision or changes.

LIMITED RIGHTS NOTICE: For units of the Department of Defense, all documentation and manuals were developed at private expense and no part of it was developed using Government Funds. The restrictions governing the use and disclosure of technical data marked with this legend are set forth in the definition of "limited rights" in paragraph (a) (15) of the clause of DFARS 252.227.7013. Unpublished - rights reserved under the Copyright Laws of the United States.

TRADEMARK NOTICE: Sensormatic and the Sensormatic logo are trademarks or registered trademarks of Sensormatic Electronics Corporation. Wiremold is a registered trademark of the Wiremold Company. Other product names mentioned herein may be trademarks or registered trademarks of Sensormatic or other companies.

No part of this guide may be reproduced in any form without written permission from Sensormatic Electronics Corporation.

RWH 07/02