

Ultra•Post Plus Power Pack

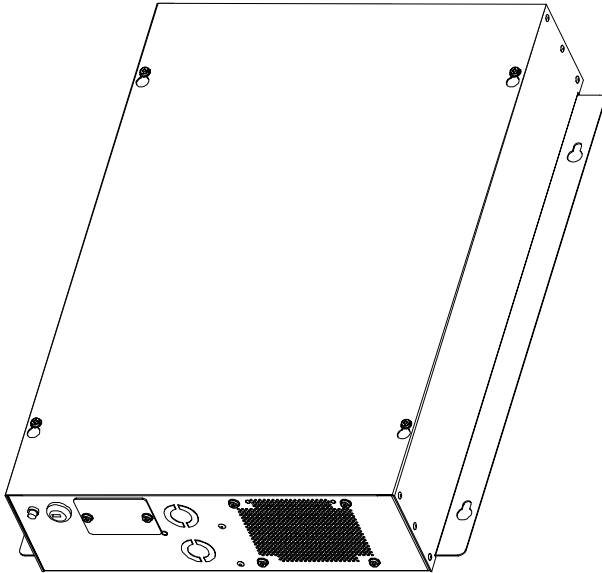

Contents

About this Guide.....	1
Limitation of Warranty	1
Power Pack Overview	2
Installation Requirements	2
Electrical Requirements	2
Installing the Power Pack.....	3
Installing the Transformer	4
Connecting the Remote Alarm Cable	5
Connecting Power to the Power Pack.....	6
Specifications	7
Declarations	8

About this Guide

This installation guide explains how to install the Ultra•Post™ Plus Power Pack. Other related documents are:

- Planning Guide, 8000-2642-01
- Setup and Service Guide, 8000-2642-xx
- Reference Guide, 8000-2642-xx

Note: Because placement of system components depends on architectural and customer requirements, your Sensormatic representative will supply this information separately.

If you need assistance...

Call Sensormatic Customer Support at:
1-800-543-9740

Limitation of Warranty

Any deviations from the materials or procedures specified herein shall void Sensormatic's warranty with the owner/buyer. In no event shall Sensormatic be liable for loss or damage caused by the use of materials or procedures that do not meet Sensormatic's specifications.

Ultra•Max, *Sensormatic*, and the *Sensormatic logo* are registered trademarks and *Ultra•Post* is a trademark of Sensormatic Electronics Corporation. Other product names (if any) mentioned herein may be trademarks or registered trademarks of other companies.

No part of this guide may be reproduced in any form without written permission from Sensormatic Electronics Corporation.

© Copyright 1999. All rights reserved.

DOJ 5/99

Power Pack Overview

The Ultra•Post Plus Power Pack is part of an Ultra•Max security label detector. The power pack controls up to two transceiver antennas and two remote alarms.

Figure 1. Ultra•Max Detector

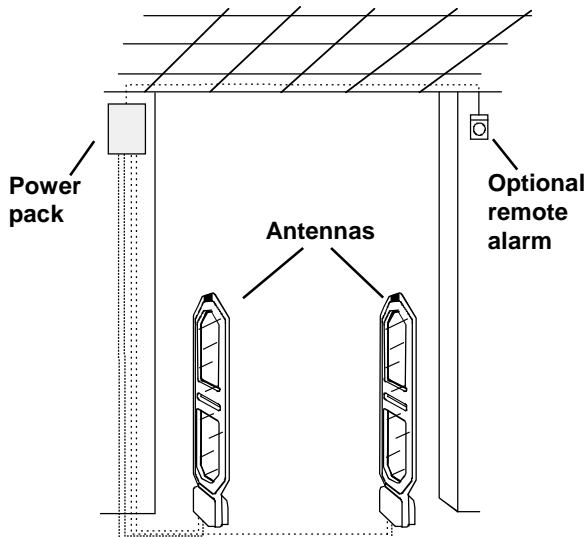

The Ultra•Post Plus Power Pack (0100-xxxx-xx) ships with the antennas or can be ordered separately.

Installation Requirements

Verifying Equipment and Unpacking

- Verify that all equipment has arrived. Make sure the system configuration is the right one for the installation site.
- Unpack major components in a back room. At the install site, lay out parts in the order you will need them. Do not clutter the aisle or cause a trip hazard.

Installer/Contractor

- Shall have electrical work comply with the latest national electrical code, national fire code, and all applicable local codes and ordinances.
- Shall coordinate all work with other trades to avoid interference.
- Shall verify existing site conditions and coordinate with the owner's representative and appropriate utilities as required.
- Shall obtain copies of all related plans, specifications, shop drawings and addenda to schedule and coordinate related work.
- Shall thoroughly review the project to ensure that all work meets or exceeds the above requirements. Any alleged discrepancies shall be brought to the attention of Sensormatic Electronics.



WARNING!

Do not install this product in hazardous areas where highly combustible or explosive products are stored or used.

Electrical Requirements

- Connect the pack to a 100-120Vac or 220-240Vac source. No fuse exchange is required.
- The ac source must be unswitched with less than 0.5Vac between neutral and ground.
- DO NOT share the ac source with neon signs, motors, computers, cash registers, terminals, or data communications equipment.
- DO NOT use orange-colored outlets dedicated for computer equipment.

Power Pack

- ❑ The pack can be placed on a shelf or mounted on a wall. The pack can be hidden in a remote location such as checkout counter, backroom, or basement. DO NOT mount the pack with the power cord and fan on top. Refer to Figure 2.
- ❑ The pack can be mounted in an air handling space other than a duct or plenum with the air handling kit.
- ❑ Provide a minimum of 20cm (8") of unobstructed space around the pack for ventilation.
- ❑ Use the appropriate power cord based on the country of use.

USA-IEC 320, 18/3, 125V, 10A, 7.5ft.	0351-0547-01
Schuko-IEC 320, 1mm sq., 250V, 10A, 2.5m	0351-0547-02
UK-IEC 320, 1mm sq., 250V, 10A, 2.5m	0351-0547-03
Japan-IEC 320, 2mm sq., 250V, 15A, 2.5m	0351-0547-04
US-Filter, Line, 125V, 6A, Plug-in	0351-0547-05
Australia to IEC 320, 2.5m, 250V, 10A	0351-0547-07
- ❑ Replace the pack's slow-blow fuses only with a fuse of the same type and rating.
- ❑ Maximum cable distance from the antennas to the power pack is 12.2m (40').

EC76/MC76 Remote Alarm Unit (if used)

- ❑ Plug the transformer used to power the alarm into a 24-hour, unswitched outlet.
- ❑ Maximum cable distance from the power pack to each alarm unit is about 7.6m (25').

Tools and Equipment Required

For all system installations:

- 6 mil (minimum) plastic sheeting (to protect nearby items from dust)
- Permanent marker and/or pencil
- Hammer drill with 6.5mm (1/4") and 9.6mm (3/8") masonry drill bits
- Power drill with 1.6mm (1/16"), 6.5mm (1/4"), and 9.6mm (3/8") drill bits
- Hammer
- Phillips and slotted screwdrivers
- Ratchet and socket set
- Vacuum and broom

Installing the Power Pack

The pack can rest on a shelf (no mounting procedure required) or can be hung on a wall.

To mount the pack on a wall, proceed to the section "**Wall-mounting the Power Pack**" on **page 3**.

Otherwise, go to "**Installing the Transformer**" on **page 4**.

Wall-mounting the Power Pack

1. Mark and drill holes and insert anchors.

- a. Use the paper template to mark holes. Position template on wall and level it to mark the four mounting hole locations. Mounting holes are 40.6cm (16") apart.
- b. Drill holes for hollow wall (wall-board) anchors.
- c. Tap anchors into holes.

2. Mount the pack on the wall.

Secure pack to wall with screws provided.

DO NOT mount the pack with the power cord and fan on top. Refer to Figure 2.

Mounting the power pack is complete. Go to "**Installing the Transformer**" on **page 4**.

Figure 2. Wall-mounting orientations

Fan

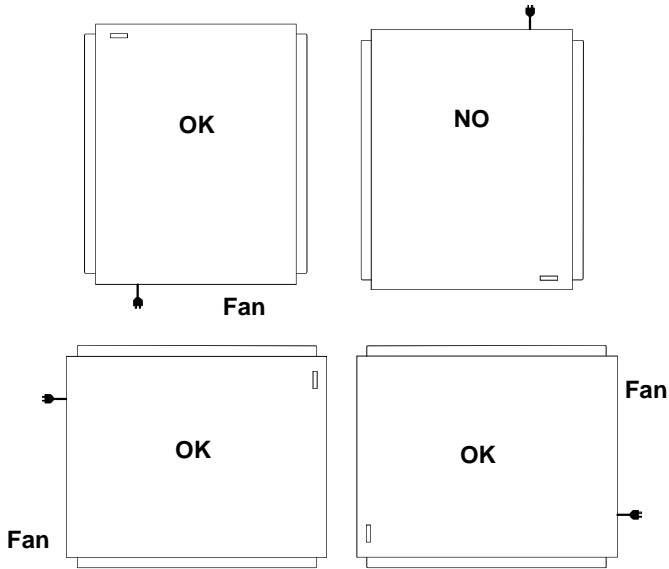

Installing the Transformer

A universal transformer (0300-0914-02), used to power an external alarm, can be installed in the power pack.

If a transformer is to be installed in the power pack, continue.

Otherwise, proceed to “**Connecting the Remote Alarm Cable**” on **page 5**.

To install the transformer, do the following:

1. **Make sure the power select module in the transformer is set for the correct ac voltage.**
 - a. Using a small screwdriver, remove the power select module.
 - b. Insert the correct fuse for the input ac voltage (.63A for 120Vac, .31A for 240Vac).
 - c. Rotate voltage selector so that the input voltage appears through the power select window.
 - d. Re-insert the power select module.
2. **Secure the transformer to the mounting bosses in the power pack using four nuts.**
3. **Plug the transformer into the ac power outlet.**

Installing the transformer is complete. Proceed to “**Connecting the Remote Alarm Cable**” on **page 5**.

Connecting the Remote Alarm Cable

If a remote alarm is to be connected to the power pack, continue.

Otherwise, proceed to “**Connecting Power to the Power Pack**” on page 6.

The power pack provides two connectors, J2 and JP3, to control remote alarms. Connector J2 provides alarm signals for pedestal 1; connector JP3 provides alarm signals for pedestal 2. When a pedestal detects an alarm condition, a dry contact relay closure signals the alarm. Each connector can support up to two remote alarms.

Remote alarm cables enter the power pack through the remote alarm knockout on the bottom of the pack.

Connector J2 is located on the receiver/controller board. Connector J2 relay connections are:

Pin 1	Ground
Pin 2	Not used
Pin 3	NO 2
Pin 4	COM 2
Pin 5	NC 2
Pin 6	NO 1
Pin 7	COM 1
Pin 8	NC 1

Connector JP3 is located on the alarm board. It has a color-coded label. Connector JP3 relay connections are:

Pin 1 - white	AC In
Pin 2 - violet	DC Out
Pin 3 - blue	Ground
Pin 4 - green	NO 2
Pin 5 - yellow	COM 2
Pin 6 - orange	NC 2
Pin 7 - red	NO 1
Pin 8 - brown	COM 1
Pin 9 - black	NC 1

When both pedestals control a single remote alarm, connect normally open and common pins in parallel. Refer to Figure 3.

Figure 3. Remote alarm wiring (multiple pedestals)

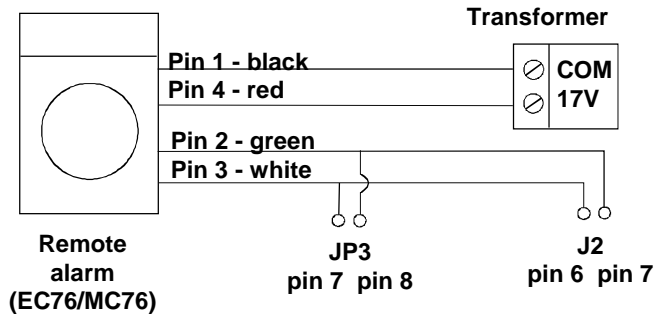
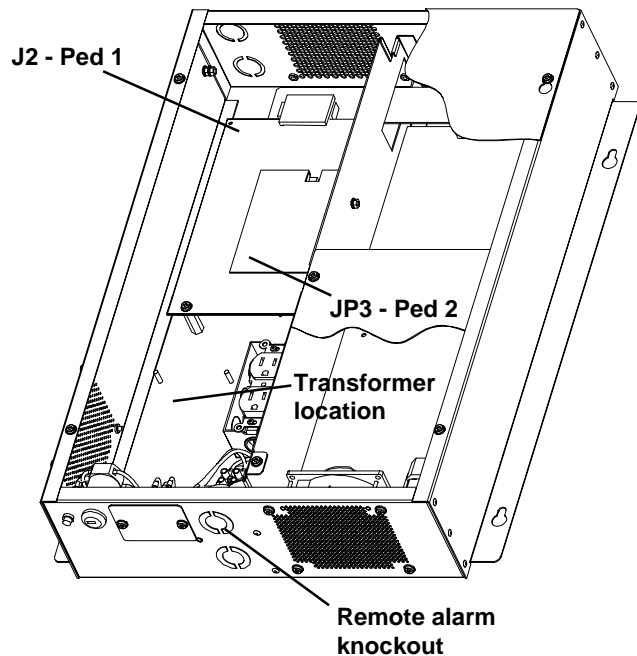



Figure 4. Transformer and remote alarm connection



Connecting Power to the Power Pack

	<p>For installation using a line cord, the socket-outlet must be installed near the equipment and at a location which is easily accessible.</p> <p>Für Installationen mit einem Stromkabel muß die Steckdose an einem Standort installiert werden, welcher einfachen Zugang erlaubt.</p>
-----------------------------------------------------------------------------------	-------------------------------------------------------------------------------------------------------------------------------------------------------------------------------------------------------------------------------------------------------------------------------------------------

	<p>A 6A, 2 pole, ganged disconnect device, which also provides short circuit and overload protection, and has a minimum 3mm open circuit clearance, in accordance with the National Electric Code and applicable local codes must be installed by a licensed electrician at a location readily accessible to the equipment.</p> <p>Ein 6A, 2-poliges, gekoppeltes Ausschaltgerät, welches auch über einen Kurzschluß- sowie Überbelastungsschutz verfügt, und einen minimum 3mm offenen Schaltabstand aufweist, nach Übereinstimmung mit den Nationalen Elektrischen Regelungen sowie lokalen Regeln, muß an einem Standort installiert werden, welcher einfachen Zugang zum Gerät erlaubt.</p>
-----------------------------------------------------------------------------------	--------------------------------------------------------------------------------------------------------------------------------------------------------------------------------------------------------------------------------------------------------------------------------------------------------------------------------------------------------------------------------------------------------------------------------------------------------------------------------------------------------------------------------------------------------------------------------------------------------------------------------------------------------------------------------------------------------

The AC power source can be 100-120Vac or 220-240Vac. AC power can be hardwired to the power pack or connected by an ac power cord.

	<p>WARNING—RISK OF ELECTRIC SHOCK!</p> <p>The AC power line could be carrying 120Vac or 240Vac.</p>
-------------------------------------------------------------------------------------	------------------------------------------------------------------------------------------------------------

To connect ac power to the power pack, do the following:

1. Make sure power select jumpers located behind metal cover are set for the correct ac voltage.

Place jumper JW1 IN for 120Vac or OUT for 240Vac; place jumper JW12 across pins 2-2 for 120Vac or across pins 1-2 for 240Vac. To access JW1 and JW12, remove metal cover.

2. Connect ac power to the pack.

If ac power is connected by a power cord, remove the metal cover over the IEC connector and attach the power cord.

If ac power is hardwired, route power cable through knockout on bottom of power pack. Connect the ac power wires to the ac terminal block inside the power pack. Connect black to L (line), white to N (neutral), and green to ground.

Power pack installation is complete.

Figure 5. Connecting power

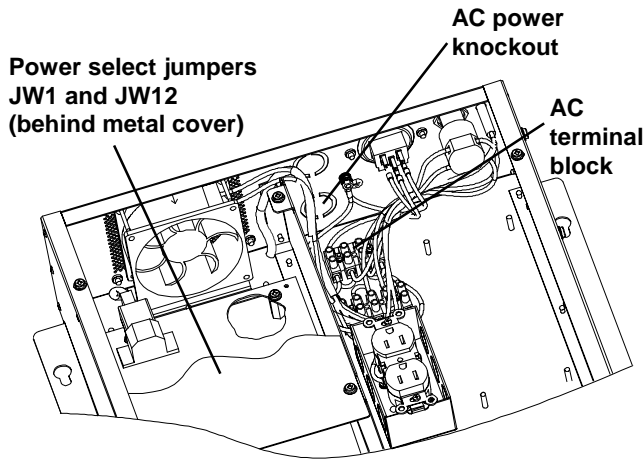

European power pack

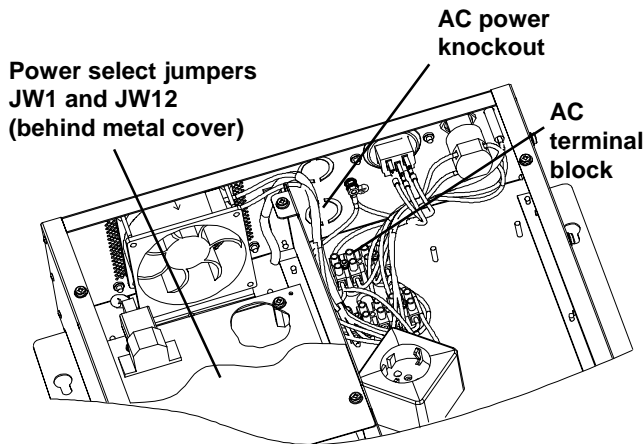

Specifications

Electrical

Power Supply

Primary Input: 100-120Vac or
220-240Vac
@ 50-60Hz

Primary Power Fuse: 3A, 250V slo-blow

Current Draw: 2.0A peak

Input Power: <180W

Transmitter

Outputs: 2 ports (two antennas,
multiplexed)

Operating Frequency: 58 or 60kHz (± 200 Hz)

Transmit Burst Duration 1.6ms

Transmit Current: 16A peak

Burst Repetition Rate:

Based on 50Hz ac 37.5Hz (Normal)
..... 75Hz (Validation)

Based on 60Hz ac 45Hz (Normal)
..... 90Hz (Validation)

Receiver

Inputs: 2 ports (two antennas,
multiplexed)

Center Frequency: 58 or 60kHz

Alarm

Alarm Relay Output DPDT contacts

Contact Switching Current 1.0A max.

Contact Switching Voltage 28V max.

Lamp/Audio Duration 1-30 sec.
(1 sec. increments)

Environmental

Operating Temperature 0° to 50°C (32°-122°F)

Relative Humidity 0 to 90% non-condensing

Mechanical

UltraPost Plus Power Pack

Length 55.8cm (22.0")
Width..... 37.6cm (14.8")
Width (including flange) 43.1cm (17.0")
Depth 11.0cm (4.3")
Weight..... 11.1kg (24.5 lbs.)

Remote Alarm / Message Unit

Height..... 20.3cm (8")
Length 15cm (5.9")
Width..... 6.4cm (2.5")

Declarations

Regulatory Compliance

Safety: UL 1950
Can/CSA C22.2 No. 950
EN60950

Antennas in "phase aiding":

EMC: 47 CFR, Part 15

Antennas in "figure 8":

EMC: 47 CFR, Part 15,
I-ETS 300330 1994
ETS 300683 1997
EN 61000-3-2 1995/
AZ:1998
EN 61000-3-3 1995

FCC COMPLIANCE: This equipment complies with Part 15 of the FCC rules for intentional radiators and Class A digital devices when installed and used in accordance with the instruction manual. Following these rules provides reasonable protection against harmful interference from equipment operated in a commercial area. This equipment should not be installed in a residential area as it can radiate radio frequency energy that could interfere with radio communications, a situation the user would have to fix at their own expense.

EQUIPMENT MODIFICATION CAUTION: Equipment changes or modifications not expressly approved by Sensormatic Electronics Corporation, the party responsible for FCC compliance, could void the user's authority to operate the equipment and could create a hazardous condition.

Other Declarations

WARRANTY DISCLAIMER: Sensormatic Electronics Corporation makes no representation or warranty with respect to the contents hereof and specifically disclaims any implied warranties of merchantability or fitness for any particular purpose. Further, Sensormatic Electronics Corporation reserves the right to revise this publication and make changes from time to time in the content hereof without obligation of Sensormatic Electronics Corporation to notify any person of such revision or changes.

LIMITED RIGHTS NOTICE: For units of the Department of Defense, all documentation and manuals were developed at private expense and no part of it was developed using Government Funds. The restrictions governing the use and disclosure of technical data marked with this legend are set forth in the definition of "limited rights" in paragraph (a) (15) of the clause of DFARS 252.227.7013. Unpublished - rights reserved under the Copyright Laws of the United States.