INSTRUCTION MANUAL

435B

2650W VHF High Band Transmitter

AXCERA, LLC

103 FREEDOM DRIVE P.O. BOX 525 LAWRENCE, PA 15055-0525 USA
(724) 873-8100 • FAX (724) 873-8105
www.axcera.com • info@axcera.com



TABLE OF CONTENTS

CHAPTER 1 INTRODUCTION

1.1 Manual Overview	1-1
1.2 Assembly Designation Procedure	1-1
1.3 Safety	1-1
1.4 Maintenance.....	1-2
1.5 Material Return Procedure	1-2
1.6 Limited One-Year Warranty for Axcera Products.....	1-3

CHAPTER 2 SYSTEM DESCRIPTION AND REMOTE INTERFACE CONNECTIONS

2.1 System Overview.....	2-1
2.2 Control and Status.....	2-2
2.2.1 VHF Exciter Tray	2-3
2.2.2 VHF High Band Amplifier Tray.....	2-5
2.3 Input Connections.....	2-6
2.4 AC Input to the transmitter.....	2-6
2.5 Remote Interface Connections	2-6

CHAPTER 3 INSTALLATION AND SETUP PROCEDURES

3.1 Site Considerations	3-1
3.2 Unpacking the Cabinets and Trays.....	3-4
3.3 Installing the Cabinets and Trays.....	3-5
3.4 Setup and Operation	3-6

CHAPTER 4 CIRCUIT DESCRIPTIONS

4.1 VHF High Band Exciter	4-1
4.1.1 Aural IF Synthesizer Board, 4.5 MHz	4-1
4.1.2 Sync Tip Clamp/Modulator Board	4-2
4.1.3 Delay Equalizer Board.....	4-6
4.1.4 IF Carrier Oven Oscillator Board.....	4-6
4.1.5 ALC Board, NTSC	4-7
4.1.6 IF Phase Corrector Board	4-13
4.1.7 VHF Mixer/Amplifier Enclosure Assembly.....	4-15
4.1.8 Transmitter Control Board	4-17
4.1.9 Visual/Aural Metering Board	4-22
4.1.10 Channel Oscillator Assembly, Dual Oven	4-23
4.1.11 (Optional) EEPROM FSK Identifier Board	4-23
4.1.12 (Optional) IF Attenuator Board.....	4-24
4.2 VHF High Band Amplifier Trays.....	4-24

CHAPTER 5 DETAILED ALIGNMENT PROCEDURES

5.1 VHF High Band Exciter Tray with Baseband Video and Audio Inputs.....	5-1
5.2 VHF Exciter Tray with 4.5-MHz Composite Input Kit	5-1
5.3 VHF Exciter Tray with Either Baseband or 4.5-MHz Composite Input	5-2
5.4 IF Phase Corrector Adjustment	5-3
5.5 Linearity Corrector Adjustment	5-3
5.6 Phase and Gain Adjustment of the VHF Amplifier Trays.....	5-4

TABLE OF CONTENTS (continued)

5.7 Calibration of the Forward Output Power Level of the Transmitter	5-5
5.8 Calibration of the Reflected Output Level of the Transmitter	5-5
5.9 2-Way Combiner Assembly	5-6
5.10 Bandpass Filter Assemblies	5-6
5.11 VHF High Band Amplifier Tray	5-6
5.11.1 AGC Control Board	5-6
5.11.2 Phase Shifter Board	5-7
5.11.3 VHF Filter/Amplifier Board	5-7
5.11.4 VHF High Band Amplifier Board	5-7
5.11.5 Overdrive Protection Board	5-7
5.11.6 VHF High Band Amplifier Board	5-7
5.11.7 3-Way Splitter Board	5-8
5.11.8 VHF High Band Amplifier Board	5-8
5.11.9 3-Way Combiner Board	5-8
5.11.10 Calibration of the Visual Plus Aural Output Power and VSWR Cutback	5-8
5.12 Board Level Alignment Procedures	5-9
5.12.1 (Optional) 4.5-MHz Composite Input Kit	5-9
5.12.2 Delay Equalizer Board	5-10
5.12.3 (Optional) Composite 4.5-MHz Filter Board	5-10
5.12.4 (Optional) 4.5-MHz Bandpass Filter Board	5-10
5.12.5 IF Carrier Oven Oscillator Board	5-11
5.12.6 Sync Tip Clamp/Modulator Board	5-11
5.12.7 Aural IF Synthesizer Board, 4.5 MHz	5-13
5.12.8 ALC Board (Part 1 of 2)	5-14
5.12.9 IF Phase Corrector Board	5-15
5.12.10 ALC Board, NTSC (Part 2 of 2)	5-15
5.12.11 Channel Oscillator Board, Dual Oven	5-16
5.12.12 x4 Multiplier Board	5-16
5.12.13 VHF Filter/Mixer Board	5-16
5.12.14 VHF High Band Filter/Amplifier Board	5-17

APPENDICES

APPENDIX A SYSTEM SPECIFICATIONS

APPENDIX B SAMPLE LOG REPORT SHEET & TYPICAL OPERATIONAL READINGS

APPENDIX C ASSEMBLY DRAWINGS

APPENDIX D SUBASSEMBLY DRAWINGS

LIST OF FIGURES

4-1	1 kW Minimum Ventilation Configuration.....	4-4
4-2	Chassis Trak Cabinet Slides	4-5
5-1	Waveform.....	5-12

LIST OF TABLES

2-1	435B Major Trays and Assemblies	2-1
2-2	VHF Exciter Tray Meters	2-3
2-3	VHF Exciter Tray Switches	2-4
2-4	VHF Exciter Tray Fault Indicators	2-4
2-5	VHF Exciter Tray Samples	2-5
2-6	VHF Amplifier Tray Switches	2-6
2-7	VHF Amplifier Tray Fault Indicators	2-7
2-8	VHF Amplifier Tray Control Adjustments	2-7
2-9	VHF Amplifier Tray Sample	2-7
2-10	VHF Exciter Remote Interface Connections With the A/V Input and Remote Interface Assembly	2-8
2-11	VHF Amplifier Tray Remote Interface Connections With the A/V Input and Remote Interface Assembly	2-10
3-1	VHF Amplifier Tray Boards and Assemblies	3-25
5-1	Bandpass Filter Typical Values	5-6
5-2	ALC Board LEDs	5-14

Chapter 1 Introduction

1.1 Manual Overview

This manual explains the installation, setup, alignment, and maintenance procedures for the 435B 2650-Watt solid state VHF high band transmitter. It is important that you read all of the instructions, especially the safety information in this chapter, before you begin to install or operate the unit.

This instruction manual is divided into five chapters and supporting appendices. Chapter 1, Introduction, contains information on the assembly numbering system used in the manual, safety, maintenance, return procedures, and warranties. Chapter 2, System Description, Maintenance and Remote Interface Connections, describes the transmitter and includes discussions on system control and status indicators, maintenance, and remote control connections. Chapter 3, Installation and Setup Procedures, describes how to unpack, install, setup, and operate the transmitter. Chapter 4, Circuit Descriptions, contains a detailed discussion of the circuits and boards that make up the 435B transmitter. Chapter 5, Detailed Alignment Procedures, provides information on adjusting the system to achieve peak operation of the assemblies. The appendices contain system specifications, a sample log sheet, schematic, interconnects, assembly and subassembly drawings and parts list.

1.2 Assembly Designation Procedure

Axcera has assigned assembly numbers, such as Ax (x=1,2,3...), to all assemblies, trays, and boards that are referenced in the text of this manual and shown on the block diagrams and interconnect drawings provided in the appendices. These supporting documents are arranged in increasing numerical order in

the appendices. Section titles in the text for assembly or tray descriptions or alignment procedures also indicate the associated drawing(s) and the relevant appendix that contains the drawing. Sections describing vendor-supplied items, such as meters and power supplies, do not contain this information.

1.3 Safety

The VHF transmitters manufactured by Axcera are designed to be easy to use and repair while providing protection from electrical and mechanical hazards. Listed throughout the manual are notes, cautions, and warnings concerning possible safety hazards that may be encountered while operating or servicing the transmitter. Please review these warnings and familiarize yourself with the operation and servicing procedures before working on the transmitter.

Read All Instructions – All of the operating and safety instructions should be read and understood before operating this equipment.

Retain Manuals – The manuals for the transmitter should be retained at the transmitter site for future reference. We provide two sets of manuals for this purpose; one set can be left at the office while one set can be kept at the site.

Heed all Notes, Warnings, and Cautions – All of the notes, warnings, and cautions listed in this safety section and throughout the manual must be followed.

Follow Instructions – All of the operating and use instructions for the transmitter should be followed.

Cleaning – Unplug or otherwise disconnect all power from the equipment before cleaning. Do not use liquid or

aerosol cleaners. Use a damp cloth for cleaning.

Ventilation – Openings in the cabinets and tray front panels are provided for ventilation. To ensure reliable operation of the transmitter, and to protect the unit from overheating, these openings must not be blocked.

Servicing – Do not attempt to service this product yourself until becoming familiar with the equipment. If in doubt, refer all servicing questions to qualified Axcera service personnel.

Replacement Parts – When replacement parts are used, be sure that the parts have the same functional and performance characteristics as the original part. Unauthorized substitutions may result in fire, electric shock, or other hazards. Please contact the Axcera Technical Service Department if you have any questions regarding service or replacement parts.

1.4 Contact Information

The Axcera Field Service Department can be contacted by phone at **(724) 873-8100** or by fax at **(724) 873-8105**.

Before calling Axcera, please be prepared to supply the Axcera technician with answers to the following questions. This will save time and help ensure the most direct resolution to the problem.

1. What are the Customers' Name and call letters?
2. What are the model number and type of transmitter?
3. How long has the transmitter been on the air? (Approximately when was the transmitter installed)
4. What are the symptoms being exhibited by the transmitter?
Include current front panel meter readings. If possible, include front panel meter readings before the problem occurred.

1.5 Material Return Procedure

To insure the efficient handling of equipment or components that have been returned for repair, Axcera requests that each returned item be accompanied by a Material Return Authorization Number (MRA#).

An MRA# can be obtained from any Axcera Field Service Engineer by contacting the Axcera Field Service Department at (724) 873-8100 or by fax at (724) 873-8105. This procedure applies to all items sent to the Field Service Department regardless of whether the item was originally manufactured by Axcera.

When equipment is sent to the field on loan, an MRA# is included with the unit. The MRA# is intended to be used when the unit is returned to Axcera. In addition, all shipping material should be retained for the return of the unit to Axcera.

Replacement assemblies are also sent with an MRA# to allow for the proper routing of the exchanged hardware. Failure to close out this type of MRA# will normally result in the customer being invoiced for the value of the loaner item or the exchange assembly.

When shipping an item to Axcera, please include the MRA# on the packing list and on the shipping container. The packing slip should also include contact information and a brief description of why the unit is being returned.

Please forward all MRA items to:

Axcera, LLC
103 Freedom Drive
P.O. Box 525
Lawrence, PA 15055-0525 USA

For more information concerning this procedure, call the Axcera Field Service Department.

Axcera can also be contacted through e-mail at **info@axcera.com** and on the Web at **www.axcera.com**.

1.6 Limited One Year Warranty for Axcera Products

Axcera warrants each new product that it has manufactured and sold against defects in material and workmanship under normal use and service for a period of one (1) year from the date of shipment from Axcera's plant, when operated in accordance with Axcera's operating instructions. This warranty shall not apply to tubes, fuses, batteries, or bulbs.

Warranties are valid only when and if (a) Axcera receives prompt written notice of breach within the period of warranty, (b) the defective product is properly packed and returned by the buyer (transportation and insurance prepaid), and (c) Axcera determines, in its sole judgment, that the product is defective and not subject to any misuse, neglect, improper installation, negligence, accident, or (unless authorized in writing by Axcera) repair

or alteration. Axcera's exclusive liability for any personal and/or property damage (including direct, consequential, or incidental) caused by the breach of any or all warranties, shall be limited to the following: (a) repairing or replacing (in Axcera's sole discretion) any defective parts free of charge (F.O.B. Axcera's plant) and/or (b) crediting (in Axcera's sole discretion) all or a portion of the purchase price to the buyer.

Equipment furnished by Axcera, but not bearing its trade name, shall bear no warranties other than the special hours-of-use or other warranties extended by or enforceable against the manufacturer at the time of delivery to the buyer.

NO WARRANTIES, WHETHER STATUTORY, EXPRESSED, OR IMPLIED, AND NO WARRANTIES OF MERCHANTABILITY, FITNESS FOR ANY PARTICULAR PURPOSE, OR FREEDOM FROM INFRINGEMENT, OR THE LIKE, OTHER THAN AS SPECIFIED IN PATENT LIABILITY ARTICLES, AND IN THIS ARTICLE, SHALL APPLY TO THE EQUIPMENT FURNISHED HEREUNDER.

Chapter 2

System Description, Maintenance and Remote Interface Connections

The 435B is a complete 2650 watt VHF high band solid state internally diplexed television transmitter that operates at a nominal visual output power of 2650 watts peak sync and an average aural output power of 265 watts, at an A/V

ratio of 10 dB, 10% sound, or 132.5 watts at 13 dB, 5% sound.

2.1 System Overview

The 435B is made up of the trays and assemblies listed in Table 2-1.

Table 2-1. 435B Major Trays and Assemblies

MAJOR ASSEMBLY DESIGNATOR	TRAY/ASSEMBLY NAME	DRAWING NUMBER
A2	AC distribution panel	1265-1600
A4	VHF exciter	1070901
A6, A7, A13, A14	Four VHF amplifier trays	1301169
A8	VHF combiner assembly	1219-1006
A12	Remote interface assembly	1083510

The (A4) VHF exciter can operate using either the baseband audio and video inputs alone or, if the (optional) 4.5-MHz composite input kit is purchased, the 4.5-MHz composite input or the baseband video and audio inputs to produce a diplexed, modulated, and on-channel frequency visual + aural RF output. The switching is accomplished by a relay on the sync tip clamp modulator board that uses a baseband select to control a relay that selects either the 4.5 MHz generated from the baseband inputs or from the 4.5-MHz composite input.

To operate the transmitter with the (optional) 4.5-MHz composite input kit using baseband inputs, the baseband video must be connected to J1 or J2, the baseband audio must be connected to the proper input jack, and a baseband select must be connected from J7-6 and J7-7. To operate the transmitter with the (optional) 4.5-MHz composite input kit using the 4.5-MHz composite input, the 4.5-MHz composite input must be connected to J1 or J2 and the baseband select must be removed from J7-6 and J7-7.

The RF output of the VHF exciter is split four ways in (A5) the 4-way power splitter assembly. The outputs of the splitter feed the four (A6,A7,A13,A14) VHF high band amplifier trays that amplify the RF signals to approximately 750 watts pk. of sync each. The outputs of the four VHF amplifier trays are combined in (A8) a VHF combiner assembly that provides approximately 2650 watts peak of sync output. The 2650 watt output is connected to (A9) a bandpass filter assembly. The bandpass filter is tuned to provide the high out-of-band rejection of unwanted products. The filter assembly provides a forward and a reflected power sample to the visual/aural metering board in the VHF exciter. The forward sample is processed to provide peak detected visual and aural power output samples to the transmitter control board in the VHF exciter. The reflected power sample is also peak detected and wired to the transmitter control board. The transmitter control board connects the visual, aural, and reflected power output samples to the front panel meter for monitoring the system.

In the VHF amplifier tray, a forward power sample and a reflected power sample from the 3-way combiner board are connected to the AGC Control Board that peak-detects the samples and connects them to the front panel meter of the tray.

2.2 Control and Status

Control and status information for the transmitter is provided by the meter and LED indicators on the front panel of the VHF exciter. The switches and LED indicators are part of the (A17) transmitter control board that is mounted so that the switches and LEDs are operated or viewed from the front panel of the VHF exciter.

Switch S1 is an Operate/Standby switch that controls the output of the transmitter by providing the Enables that, when the transmitter is in Operate, are needed to turn on the switching power supplies in the two VHF amplifier trays. In Operate, the green LED DS2 is on and in Standby the amber LED DS1 is on. **NOTE:** If the transmitter does not switch to Operate when S1 is switched to

Operate, check that a dummy jumper plug, with a jumper between pins 21 and 22, is connected to jack J9 on (A12) the A/V input and remoter interface assembly. This jumper provides the interlock needed for the transmitter to operate. If the interlock is present, the green LED DS5, on the transmitter control board, should be lit.

Switch S2 is an Automatic/Manual switch that controls the operation of the transmitter using the presence of the video input signal. When the switch is in Automatic, the green LED DS3 is lit and, if the video input signal to the transmitter is lost, the transmitter will automatically switch to Standby. When the video input signal returns, the transmitter will automatically switch back to Operate. With the system in Manual, the amber LED DS4 is lit and the operation of the transmitter is controlled by the front panel switches. During normal operation of the transmitter, switch S2 should be in the Auto position. The front panel of the VHF exciter also has LEDs that indicate a Video Fault (Loss; red LED DS9) and VSWR Cutback (amber LED DS7).

2.2.1 VHF Exciter Tray

Table 2-2. VHF Exciter Tray Meters

METER	FUNCTION	
Meter (A4-A18)	This meter reads power in terms of a percentage of the calibrated output power level on the upper scale. The voltage level or frequency level is read on one of the bottom two scales. A full-scale reading on the top scale is 120%. 100% is equivalent to the full-rated 2650 watts peak of sync visual. The meter also reads % Aural Power, % Exciter Power, % Reflected Power, audio levels, video levels, and the ALC reading.	
	With Switch S3 in Position	Display
	Switch S3, Meter	Selects the desired ALC voltage reading, % Exciter Power, % Reflected Power, % Visual Power, % Aural Power, video level, or audio level.
	Audio (0 to 100 kHz)	Reads the audio level, ± 25 kHz balanced or ± 75 kHz composite, on the 0 to 10 scale. Will indicate baseband audio, if it is connected to the transmitter, even with the video + 4.5-MHz SCA input selected.
	ALC (0 to 10 volts)	Reads the ALC voltage level, .8 VDC, on the 0 to 10 scale.
	% Exciter (0 to 120)	Reads the % Exciter Output Power Level needed to attain 100% output of the transmitter on the top scale.
	% Aural Power (0 to 120)	Reads the % Aural Output Power of the transmitter, 100% = 265 watts at 10 dB A/V ratio, on the top scale.
	% Visual Power (0 to 120)	Reads the % Visual Output Power of the transmitter, 100% = 2650 watts peak of sync, on the top scale.
	% Reflected (0 to 120)	Reads the % Reflected Output Power, <5%, on the top scale.
	Video (0 to 1 volt)	Reads the video level, at white, on the bottom 0 to 10 scale.

Table 2-3. VHF Exciter Tray Switches

SWITCH	FUNCTION
Transmitter S1 Operate/Standby	The momentary switch S1 applies a ground to K1, a latching relay on the transmitter control board. K1 will switch either to Operate or to Standby depending on which direction S1 is pushed. When switched to Operate, the low, Enable commands are applied to the two VHF amplifier trays. These Enables will turn on the VHF amplifier trays. The opposite occurs when the switch is turned to Standby.
Mode Select S2 Auto/Manual	The momentary switch S2 applies a ground to K2, a latching relay on the transmitter control board. K2 will switch the transmitter to Automatic or Manual depending on which direction S2 is pushed. In Automatic, the video fault command from the ALC Board will control the operation of the transmitter. The transmitter will switch to Standby, after a slight delay, if the input video is lost and will switch back to Operate, quickly, when the video is restored. In Manual, the transmitter is controlled by the operator using the front panel Operate/Standby switch or by remote control.
Power Adjust (R1)	The 5 k Ω pot A20 sets the ALC level on the ALC board to set the output power of the transmitter.

Table 2-4. VHF Exciter Tray Fault Indicators

INDICATOR	DESCRIPTION
Video Loss (DS9 Red)	Indicates that the input video to the transmitter has been lost. The fault is generated on the ALC board in the VHF exciter tray.
VSWR Cutback (DS7 Amber)	Indicates that the reflected power level of the transmitter has increased above 20%; this automatically cuts back the output power level to 20%. The fault is generated on the transmitter control board in the VHF exciter tray.

Table 2-5. VHF Exciter Tray Front Panel Samples

SAMPLE	DESCRIPTION
f(IF)	A sample of the visual IF, 45.75MHz, that is taken from the sample jack on the IF carrier oven oscillator board.
f(IC)	A sample of the intercarrier signal. 4.5MHz, that is taken from the sample jack on the aural IF synthesizer board.
f(s)	A sample of the channel oscillator output that is taken from the sample jack of the channel oscillator assembly.
Exciter O/P	An output power sample of the exciter that is taken from the VHF filter/amplifier board.
Transmitter O/P	A forward power sample of the transmitter that is taken from the visual/aural metering board.

2.2.2 VHF High Band Amplifier Tray

Table 2-6. VHF High Band Amplifier Tray Switches

SWITCH	FUNCTION	
On/Off Circuit Breaker CB1	Switches 220 VAC through a 15 amp circuit breaker protection device. The switch lights if AC is present. The AC is applied to the switching power supply in the tray.	
Switch S1, Meter	Selects the desired % Visual Forward Output Power, % Visual Reflected Power reading, AGC Voltage, Power Supply Voltage, or Current	
	With Switch S1 in Position	Display
	% Forward	Reads the % Forward Output Power of the tray (100%= 750 watts peak of sync + aural)
	% Refl (Reflected)	Reads the % Reflected Output Power (<10%)
	AGC Voltage	Reads the AGC level of the tray (1 to 2 VDC)
	Power Supply	Reads the voltage from the switching power supply (+28 VDC)
	Current	Uses Switch S2 to indicate the current of transistor devices
Switch S2, Meter	Selects the current of the transistor devices on the high band amplifier boards. S1 must be in the Current position.	
	With Switch S2 in Position	Display
	I_1	Reads the current of (A4-A1) the high band amplifier board (idling current=6 amps and operating current=12 amps)
	I_2	Reads the current of (A4-A2) the high band amplifier board (idling current=6 amps and operating current=12 amps)
	I_3	Reads the current of (A4-A3) the high band amplifier board (idling current=6 amps and operating current=12 amps)
I_4	Reads the current of (A3-A2) the high band driver board (idling current=3 amps and operating current=6 amps)	

Table 2-7. VHF High Band Amplifier Tray Fault Indicators

INDICATOR	DESCRIPTION
Overdrive (DS1)	Indicates that the level of drive is too high. The protection circuit will limit the drive level to the set threshold. The fault is generated on the overdrive protection board.
Enable (DS2)	Indicates that the Enable supplied by the exciter tray is present
Module Status (DS3)	Indicates that the forward power sample level is lower than the set reference level
VSWR Cutback (DS4)	Indicates that the reflected level of the tray has increased above 20%; this will automatically cut back the output power of the tray. The fault is generated on the AGC control board.
Overtemp (DS5)	Indicates that the temperature of the (A4-A5, A4-A6 or A5-A2) thermal switch is above 175° F. When this fault occurs, the Enable to the switching power supply is immediately removed.

Table 2-8. VHF High Band Amplifier Tray Control Adjustments

ADJUSTMENT	DESCRIPTION
Phase (A7-R2)	Adjusts the phase of the RF output by approximately 70°
Gain (A6-R3)	Adjusts the gain of the RF output when the amplifier control board is in the AGC mode

Table 2-9. VHF High Band Amplifier Tray Sample

SAMPLE	DESCRIPTION
RF Front Panel Sample	Forward power sample of the tray from the AGC control board

2.3 Input Connections

The baseband video and audio inputs alone or, if the (optional) 4.5-MHz composite input kit is purchased, the 4.5-MHz composite input or the baseband video input and audio input to the transmitter, connect to the A/V Input & Remote Interface Assembly, mounted facing the rear, at the top of the cabinet. The baseband video input or the 4.5-MHz composite input connects to jack J2. The baseband balanced audio input connects to TB1 or the composite, stereo, audio to jack J3. To use the 4.5-MHz composite

input kit, the baseband audio can remain connected even if the 4.5-MHz composite input kit is used, but the baseband video must be disconnected from J2 and the 4.5-MHz composite input must be connected to J2. The baseband select command must be removed from J7-6 and J7-7.

2.4 AC Input to the Transmitter

The transmitter needs an AC input of 220 VAC at 40 amps connected to it in order to operate. The 220 VAC input connects to (A2) the AC distribution panel in the

upper middle facing the rear of the cabinet. The panel contains the terminal block TB1 to which the 220 VAC input connects.

The AC distribution panel contains four circuit breakers that supply the AC to the rest of the transmitter. The input AC is connected to the main AC circuit breaker CB1 (40 amps) that distributes the 220 VAC to the terminal block TB2. TB2 has three MOVs, VR1, VR2, and VR3, mounted to the terminal block: VR1 across Line 1, VR3 across Line 2 and VR2 connected across the two legs. The input AC is wired from TB2 through three circuit breakers, CB2, CB3, and CB4, to the rest of the transmitter. CB2 is a 10-amp circuit breaker that supplies the AC voltage to the IEC outlet strip (A2-A1) that is connected into the VHF exciter, the (optional) receiver tray, and any other optional accessories. CB3 is a 20-amp circuit breaker that supplies AC through J5 to the (A6) VHF amplifier tray #1. CB4 is a 20-amp circuit breaker that supplies AC through J6 to the (A7) VHF amplifier tray #2. When the VHF exciter circuit breaker is switched on, +12 VDC is supplied to the VHF amplifier trays for the operation of the LED status indicators in the tray.

2.5 Maintenance

The 435B is designed with components that require little or no periodic maintenance except for the routine cleaning of the fans and the front panels of the trays.

The amount of time between cleanings depends on the conditions within the transmitter room. While the electronics have been designed to function even if covered with dust, a heavy buildup of dust, dirt, or insects will affect the cooling of the components. This could

lead to a thermal shutdown or premature failure of the affected trays.

When the front panels of the trays become dust covered, the top covers should be removed and any accumulated foreign material should be removed. A vacuum cleaner, utilizing a small wand-type attachment, is an excellent way to suction out the dirt. Alcohol and other cleaning agents should not be used unless you are certain that the solvents will not damage components or the silk-screened markings on the trays and boards. Water-based cleaners can be used, but do not saturate the components. The fans and heatsinks should be cleaned of all dust or dirt to permit the free flow of air for cooling purposes.

It is recommended that the operating parameters of the transmitter be recorded from the meters on the trays and the system metering control panel at least once a month. It is suggested that this data be retained in a rugged folder or envelope. A sample format for a log sheet is provided in Appendix B. Photocopies of the log sheet should be made to allow you to make continued data entries.

2.6 Remote Interface Connections

The remote interface connections listed in Table 2-10 are made to the (A12) A/V input and remote interface assembly, mounted facing the rear near the top of the cabinet. The remote connections are made to jack J9, 37 pos "D" Conn., and jack J10, 25 pos "D" Conn., on the assembly. Refer to the transmitter interconnect drawing (1303857) for verification of the remote connections.

Table 2-10. 435B Remote Interface Connections to (A12) the A/V Input
and Remote Interface Assembly

FUNCTION	REMOTE JACK/PIN NUMBER	INTERFACE TYPE
Transmitter Enable Interlock	J9-21	J9-21 and J9-22 must be jumpered together for normal operation. The (1176-1038) jumper jack should be used.
Transmitter Enable Interlock Rtn.	J9-22	
Remote Control Commands		
Transmitter Standby (Disable)	J9-9	Contact closure
Transmitter Standby/Operate Rtn.	J9-10	
Transmitter Operate (Enable)	J9-11	Contact closure
Transmitter Manual	J9-15	Contact closure
Transmitter Auto/Manual Rtn.	J9-16	
Transmitter Auto	J9-17	Contact closure
Power Level Raise (Optional)	J9-27	Contact closure
Pwr Lvl Raise/Lower Rtn (Optional)	J9-28	
Power Level Lower (Optional)	J9-29	Contact closure
Modulator Select (Optional)	J9-31	Contact closure
Modulator Select Rtn (Optional)	J9-32	
Remote Status Indications		
Transmitter Operate (Enable) Ind.	J9-12	50 mA max current sink
Operate/Standby Ind. Return	J9-13	
Transmitter Standby (Disable) Ind.	J9-14	50 mA max current sink
Transmitter Auto Indicator	J9-18	50 mA max current sink
Auto/Manual Indicator Return	J9-19	
Transmitter Manual Indicator	J9-20	50 mA max current sink

FUNCTION	REMOTE JACK/PIN NUMBER	INTERFACE TYPE
VSWR Cutback Indicator	J9-23	50 mA max current sink
VSWR Cutback Indicator Return	J9-24	
Video Loss (Fault) Indicator	J9-25	50 mA max current sink
Video Loss (Fault) Ind. Rtn.	J9-26	
Receiver Fault (Optional)	J9-30	
Remote Metering		
Visual Output Power	J9-1	1V full scale at 1k Ω source resistance
Visual Output Power Rtn	J9-2	
Aural Output Power	J9-3	1V full scale at 1k Ω source resistance
Aural Output Power Rtn	J9-4	
Reflected Power	J9-5	1V full scale at 1k Ω source resistance
Reflected Power Rtn	J9-6	
Exciter Output Power	J9-7	1V full scale at 1k Ω source resistance
Exciter Output Power Rtn	J9-8	
Forward Output Power (A6) VHF High Band Amp	J10-1	1V full scale at 1k Ω source resistance
Forward Output Power (A6) Rtn	J10-2	
Reflected O/P Power (A6) VHF High Band Amp	J10-3	1V full scale at 1k Ω source resistance
Reflected O/P Power (A6) Rtn	J10-4	
Forward Output Power (A7) VHF High Band Amp	J10-6	1V full scale at 1k Ω source resistance
Forward Output Power (A7) Rtn	J10-7	
Reflected O/P Power (A7) VHF High Band Amp	J10-8	1V full scale at 1k Ω source resistance
Reflected O/P Power (A7) Rtn	J10-9	

Chapter 3

Installation and Setup Procedures

There are special considerations that need to be taken into account before the 435B can be installed. For example, if the installation is completed during cool weather, a heat-related problem may not surface for many months, suddenly appearing during the heat of summer. This section provides planning information for the installation and set up of the transmitter.

3.1 Site Considerations

The transmitter requires an AC input line of 220 VAC with a rating of 40 amps for the transmitter. Make sure that the proposed site for the transmitter has the necessary voltage requirements.

The 435B is designed and built to provide long life with a minimum of maintenance. The environment in which it is placed is important and certain precautions must be taken. The three greatest dangers to the transmitter are heat, dirt, and moisture. Heat is usually the greatest problem, followed by dirt, and then moisture. Over-temperature can cause heat-related problems such as thermal runaway and component failure. Each amplifier tray in the transmitter contains a thermal interlock protection circuit that will shut down that tray until the temperature drops to an acceptable level.

A suitable environment for the transmitter can enhance the overall performance and reliability of the transmitter and maximize revenues by minimizing down time. A properly designed facility will have an adequate supply of cool, clean air, free of airborne particulates of any kind, and no excessive humidity. An ideal environment will require temperature in the range of 40° F to 70° F throughout the year, reasonably low humidity, and a dust-free room. It should be noted that this is rarely if ever attainable in the real world.

However, the closer the environment is to this design, the greater the operating capacity of the transmitter.

The fans and blowers designed and built into the transmitter will remove the heat from within the trays, but additional means are required for removing this heat from the building. To achieve this, a few issues need to be resolved. The first step is to determine the amount of heat to be removed from the transmitter room. There are generally three sources of heat that must be considered. The first and most obvious is the heat from the transmitter itself. This can be determined by subtracting the average power to the antenna (700 watts) from the AC input power (3800 watts). This number in watts (3100) is then multiplied by 3.41, which gives 10,571 BTUs that needs to be removed every hour. 12,000 BTUs per hour equals one ton, so a 1 ton air conditioner will cool a 2650 watt transmitter.

The second source of heat is other equipment in the same room. This number is calculated in the same way as the equation for BTUs. The third source of heat is equally obvious but not as simple to calculate. This is the heat coming through the walls, roof, and windows on a hot summer day. Unless the underside is exposed, the floor is usually not a problem. Determining this number is usually best left up to a qualified HVAC technician. There are far too many variables to even estimate this number without reviewing the detailed drawings of the site that show all of the construction details. The sum of these three sources is the bulk of the heat that must be removed. There may be other sources of heat, such as personnel, and all should be taken into account.

Now that the amount of heat that must be removed is known, the next step is to

determine how to accomplish this. The options are air conditioning, ventilation, or a combination of the two. Air conditioning is always the preferred method and is the only way to create anything close to an ideal environment.

Ventilation will work quite well if the ambient air temperature is below 100° F, or about 38° C, and the humidity is kept at a reasonable level. In addition, the air stream must be adequately filtered to ensure that no airborne particulates of any kind will be carried into the transmitter. The combination of air conditioning for summer and ventilation during the cooler months is acceptable when the proper cooling cannot be obtained through the use of ventilation alone and using air conditioning throughout the year is not feasible.

Caution: The use of air conditioning and ventilation simultaneously is not recommended. This can cause condensation in transmitters. For tube type transmitters, this can be especially serious if the condensation forms in the tube cavity and creates damaging arcs.

The following precautions should be observed regarding air conditioning systems:

1. Air conditioners have an ARI nominal cooling capacity rating. In selecting an air conditioner, do not assume that this number can be equated to the requirements of the site. Make certain that the contractor uses the actual conditions that are to be maintained at the site in determining the size of the air conditioning unit. With the desired conditioned room temperature under 80° F, the unit must be derated, possibly by a substantial amount.
2. Do not have the air conditioner blowing directly onto the

transmitter. Condensation may occur on, or worse in, the transmitter under certain conditions.

3. Do not isolate the front of the transmitter from the back with the thought of air conditioning only the front of the unit. Cooling air is drawn in at the front of all transmitters and in the front and back of others. Any attempt to isolate the front from the rear will adversely affect the flow of cooling air.
4. Interlocking the transmitter with the air conditioner is recommended to keep the transmitter from operating without the necessary cooling.
5. The periodic cleaning of all filters is a must.

When using ventilation alone, the following general statements apply:

1. The blower, with attendant filters, should be on the inlet, thereby pressurizing the room and preventing dirt from entering the transmitter.
2. The inlet and outlet vents should be on the same side of the building, preferably the leeward side. As a result, the pressure differential created by wind will be minimized. Only the outlet vent may be released through the roof.
3. The inlet and outlet vents should be screened with 1/8-inch hardware cloth (preferred) or galvanized hardware cloth (acceptable).
4. Cooling air should enter the room as low as practical but in no case higher than four feet above the floor. The inlet must be located where dirt, leaves, snow, etc., will

- not be carried in with the cooling air.
5. The exhaust should be located as high as possible. Some ducting is usually required to insure the complete flushing of heated air with no stagnant areas.
 6. The filter area must be large enough to insure a maximum air velocity of 300 feet per minute through the filter. This is not a conservative number but a never-exceed number. In a dusty or remote location, this number should be reduced to 150 CFM.
 7. The inlet and outlet(s) must have automatic dampers that close any time the ventilation blower is off.
 8. In those cases in which transmitters are regularly off for a portion of each day, a temperature-differential sensor that controls a small heater must be installed. This sensor will monitor inside and outside temperatures simultaneously. If the inside temperature falls to within 5° F of the outside temperature, the heater will come on. This will prevent condensation when the ventilation blower comes on and should be used even in the summer.
 9. A controlled-air bypass system must be installed to prevent the temperature in the room from falling below 40° F during transmitter operation.
 10. The blower should have two speeds, which are thermostatically controlled, and be interlocked with the transmitter.
 11. The blower on high speed must be capable of moving the required volume of air into a half inch of water pressure at the required elevation. The free air delivery method must not be used.
 12. Regular maintenance of the filters, if used, can not be overemphasized.
 13. Transmitters should not rely on the internal blower to vent the cooling air at elevations above 4000 feet. For external venting, the air vent on the cabinet top must be increased to an 8" diameter for a 1kW transmitter. An equivalent rectangular duct may be used but, in all cases, the outlet must be increased by 50% through the outlet screen.
 14. It is recommended that a site plan be submitted to Axcera for comments before installation begins.
- In calculating the blower requirements, filter size, and exhaust size, if the total load is known in watts, 2000 CFM into ½ inch of water will be required for each 5000 watts. If the load is known in BTUs, 2000 CFM into ½ inch of water will be required for each 17,000 BTUs. The inlet filter must be a minimum of seven square feet, larger for dusty and remote locations, for each 5000 watts or 17,000 BTUs. The exhaust must be at least four square feet at the exhaust screen for each 5000 watts or 17,000 BTUs.
- The information presented in this section is intended to serve only as a general guide and may need to be modified for unusually severe conditions. A combination of air conditioning and ventilation should not be difficult to design (see Figure 3-1). System interlocking and thermostat settings should be reviewed with Axcera. As with any equipment installation, it is always good practice to consult the manufacturer when questions arise. Axcera can be contacted at (724) 873-8100.

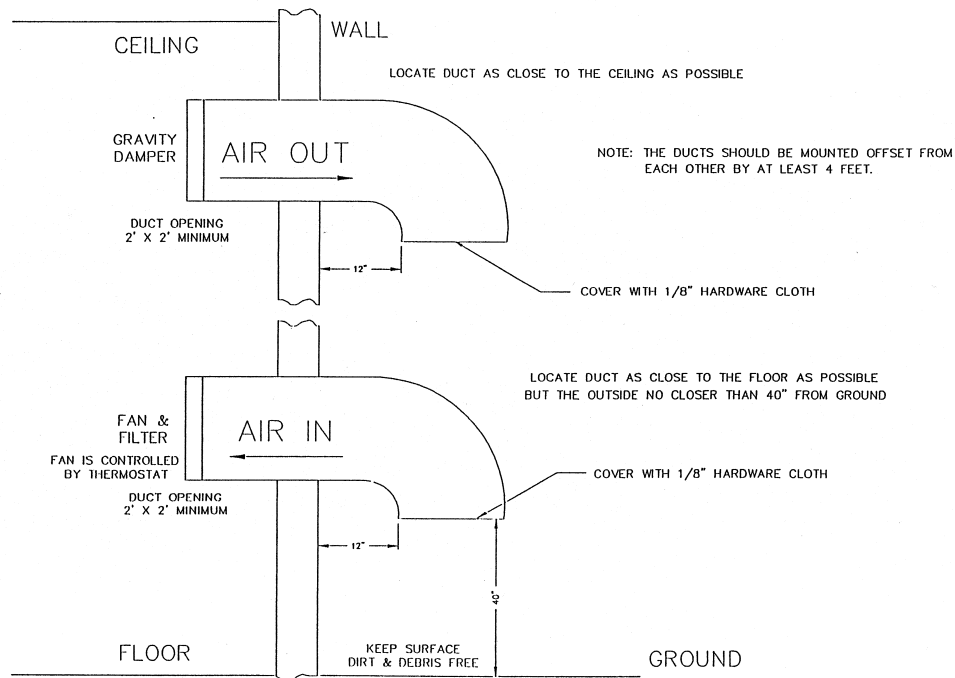

Figure 3-1. 1 kW Minimum Ventilation Configuration

3.2 Unpacking the Cabinet and Trays

Note: Air conditioning and any related heat exhaust ducts should be in place before continuing with the installation of the transmitter.

Thoroughly inspect the cabinets and all other materials upon their arrival. Axcera certifies that upon leaving our facility the equipment was undamaged and in proper working order. The shipping containers should be inspected for obvious damage that indicates rough handling. Check for dents and scratches or broken switches, meters, or connectors. Any claims against in-transit damage should be directed to the carrier. Inform Axcera as to the extent of any damage as soon as possible.

Remove the cabinet and the trays from the crates and boxes. Remove the straps that hold the cabinet to the shipping skid and slide the cabinet from the skid. Remove the plastic wrap and foam protection from around the cabinet. Do not remove any labeling or tags from any cables or connectors; these are identification markers that make assembly of the transmitter much easier.

Remove the two L-brackets, mounted on the front panel rails, which held the trays in place during shipment. The trays are mounted in the cabinet using Chassis Trak cabinet slides as shown in Figure 3-2. The tray slides are on the top and the bottom of the VHF amplifier trays and on the sides of the VHF exciter tray. Inspect the trays for any loose hardware or connectors, tightening as needed.

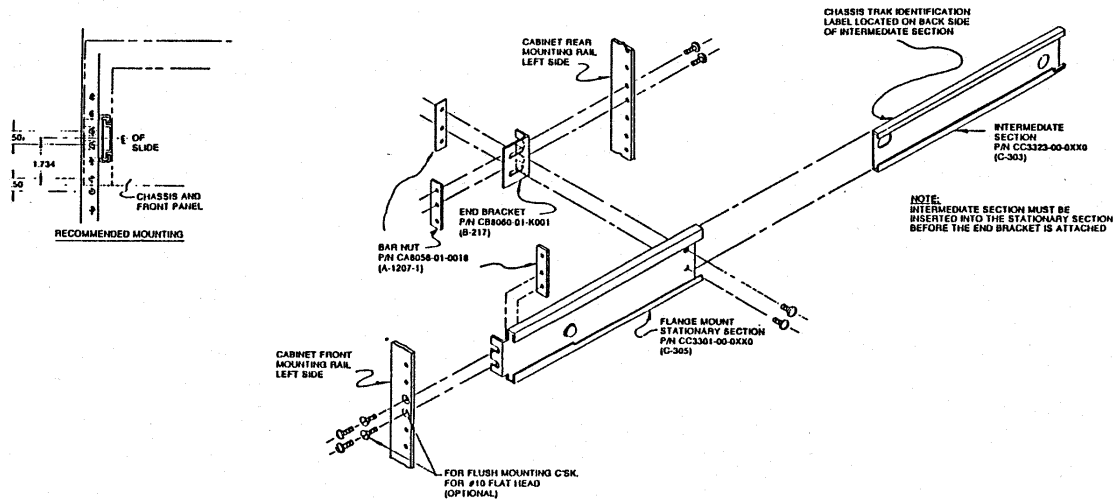

Figure 3-2. Chassis Trak Cabinet Slides

Open the rear door. Inspect the interior of the cabinet for packing materials and carefully remove any packing materials that are found. Slowly slide each tray in and out to verify that they do not rub against each other and have no restrictions to free movement.

3.3 Installing the Cabinets and Trays

It may be necessary to adjust the position of the trays to keep them from rubbing. This is accomplished by loosening the cabinet slide mounting bolts that hold the front of the slide to the mounting frame of the cabinet and moving the tray up or down, as needed, to correct for the rubbing.

The air intake to the 2650-watt transmitter is only intended for room air. The cabinet should be positioned for adequate air intake and exhaust; the opening of the rear door, if present; access to the trays, including sliding them out for testing; the main AC hookup; and the installation of the output transmission line. The cabinet should be grounded using copper strapping material and should be permanently mounted to the floor of the site using the holes in the bottom of the cabinet.

3.4 Main AC Connection

Once the cabinet is in place, and the trays are checked for damage, the main AC hookup can be made.

Caution: Before connecting the 220 VAC, make certain that all of the circuit breakers associated with the transmitter have been switched off.

The main AC input circuit to the 2650 watt transmitter should be a 40-amp, 220 VAC line, using AWG 6 wire, inside of a 1-1/4-inch conduit.

The 220 VAC input connections are made to terminal block TB1, which is part of the AC distribution panel, near the upper right hand, rear portion of the cabinet.

Connect Line 1 to TB1-1A, Line 2 to TB1-4A and chassis ground to TB1-3A.

The output of the bandpass filter assembly, which is a "1-5/8" EIA connector, should connect to the transmission line for the antenna system.

This completes the unpacking and installation of the 435B 2650 watt VHF television transmitter. Refer to the setup

and operation procedures that follow before applying power to the transmitter.

3.4 Setup and Operation

Initially, the transmitter should be turned on with the RF output at (A9-A5-J2) the bandpass filter assembly terminated into a dummy load of at least 2650 watts. If a load is not available, check that the output of the bandpass filter assembly is connected to the antenna.

Connect the baseband balanced audio input to the terminal block TB1 or the composite audio input to BNC jack J6 on the A/V input & remote interface assembly, located facing the rear of the cabinet near the top. The baseband audio input can remain connected when using the 4.5 MHz composite input without affecting the operation of the transmitter. Connect the baseband video input to BNC jack J2 also on the A/V I/P & remote interface assembly, if the (optional) 4.5 MHz composite input kit is purchased, connect the 4.5-MHz composite input to the BNC jack J2. To use the 4.5 MHz composite input, the 4.5 MHz composite input must be connected to J2 and the baseband select must be removed from J7-6 and J7-7 on the rear of the VHF Exciter tray. To use the baseband video and audio inputs, the baseband video input must be connected to J2, the baseband audio must be connected to the proper jack, and the baseband select must be connected from J7-6 and J7-7.

Switch on the main AC, VHF exciter, and the amplifier #1 and amplifier #2 circuit breakers on the AC distribution panel facing the rear of the cabinet and mounted behind the rear door. On the VHF exciter tray, switch the Operate/Standby switch to Standby and the Auto/Manual switch to Manual.

NOTE: Normal operation of the transmitter is in Automatic. Automatic operation uses the video input to the VHF exciter as an Operate/Standby switch. In Auto, if the input video is lost for

approximately 7 seconds, the transmitter will automatically revert to Standby and, when the video signal is restored, the transmitter will quickly return to Operate.

Move the Operate/Standby switch on the VHF exciter tray to Operate. Observe the power supply reading, +28 V, on the front panel of the VHF amplifier trays.

Note: If the transmitter does not switch to Operate when the Operate/Standby switch is placed in Operate, check that an external interlock plug, with a jumper wired from pins 21 to 22, is connected to jack J9 on the (A12) A/V input and remote interface assembly.

On the VHF exciter tray, look at the front panel meter reading in the % Visual Power position; it should read 100%. If necessary, readjust the screwdriver adjust power pot on the front panel of the VHF exciter for 100%. As the power level is being checked, observe the meter reading in the % Reflected Power position. If the % Reflected Power is very high, above 10%, a problem exists with the output coaxial lines and they will need to be checked. A center bullet missing from the coax lines or loose bolts on the connections can cause this problem. Return the Operate/Standby switch to Standby.

The gain and phase controls on the front panels of the individual VHF amplifier trays were adjusted at the factory to obtain an output of 100% for the transmitter and should not need to be readjusted. The front panel readings on the individual VHF amplifier trays may not be the same. Refer to the Test Data Sheet for the transmitter to compare the final readings from the factory with the readings on each of the trays after the setup. They should be very similar. If a reading is off by a significant amount, refer to the phasing and power adjustment procedures for the VHF amplifier trays in Chapter 5, Detailed Alignment Procedures, of this manual before trying to make any adjustments.

If a dummy load is connected to the transmitter, switch the unit to Standby and switch off the main AC circuit breaker. Remove the dummy load and make all of the connections that are needed to connect the transmitter to the antenna. Switch the main AC circuit breaker on and the Operate/Standby switch to Operate. Adjust the output power screwdriver pot to achieve an output of 100%.

If the transmitter is already connected to the antenna, check that the output is

100%. If necessary, adjust the power screwdriver pot.

This completes the transmitter setup and operation procedures for the 435B VHF solid state transmitter. The transmitter can now be operated normally.

If a problem occurred during the setup and operation procedures, refer to Chapter 5, Detailed Alignment Procedures, of this manual for more information.

Chapter 4 Circuit Descriptions

4.1 (A4) VHF High Band Exciter (1070901; Appendix C)

4.1.1 (A4) Aural IF Synthesizer Board, 4.5 MHz (1265-1303; Appendix D)

The aural IF synthesizer board amplifies each of the three possible audio inputs and connects them to a summing point and amplifier circuit that provides the single audio output. Either the balanced audio or the composite stereo audio input is connected to the board while the subcarrier audio (SCA) input can be connected at the same time as either of the other two inputs. The board has the 4.5-MHz voltage-controlled oscillator (VCO) and the aural modulation circuitry that produces the modulated 4.5 MHz output. The board also contains a phase lock loop (PLL) circuit that maintains the precise 4.5 MHz separation between the aural (41.25 MHz) and the visual (45.75 MHz) IF frequencies.

4.1.1.1 Balanced Audio Input

The first of the three possible baseband inputs to the board is a 600 Ω -balanced audio input. The balanced audio input (+10 dBm) enters through jack J2, pins 1 (+), 2 (GND), and 3 (-) and is buffered by U1B and U1C. The Diodes CR1 to CR4 protect the input stages of U1B and U1C if an excessive signal level is present on the input leads of jack J2. The outputs of U1B and U1C are applied to differential amplifier U1A, which eliminates any common mode signals (hum) that may be on its input leads. A pre-emphasis of 75 mS is provided by R11, C11, and R10 and can be eliminated by removing jumper W5 on J5. The signal is then applied to amplifier U1D whose gain is controlled by jumper W3 on J11. Jumper W3 on jack J11 is positioned according to the input level of the audio signal (0 or +10 dBm). If the input level is

approximately 0 dBm, the mini-jumper should be in the high gain position between pins 1 and 2 of jack J11. If the input level is approximately +10 dBm, the mini-jumper should be in low gain position between pins 2 and 3 of jack J11. The balanced audio is then connected to buffer amplifier U2A whose input level is determined by the setting of balanced audio gain pot R13. The output of the amplifier stage is wired to the summing point at U2D, pin 13.

4.1.1.2 Composite Audio Input

The second possible audio input to the board is the composite audio (stereo) input at the BNC jacks J3 or J13. The two jacks are loop-through connected; as a result, the audio can be used in another application by connecting the unused jack and removing the jumper W4 from J12. Jumper W4 on jack J12 provides a 75 Ω input impedance when the jumper is between pins 1 and 2 of jack J12 and a high impedance when it is between pins 2 and 3. Diodes CR9 to CR12 protect the input stages of U6A and U6B if an excessive signal level is applied to the board. The outputs of U6A and U6B are applied to the differential amplifier U2C, which eliminates common mode signals (hum) on its input leads. The composite input signal is then applied to amplifier U2B whose gain is controlled by the composite audio gain pot R17. The composite audio signal is then connected to the summing point at U2D, pin 13.

4.1.1.3 Subcarrier Audio Input

The third possible input to the board is the SCA input at BNC jack J4. The SCA input has an input impedance of 75 Ω that can be eliminated by removing jumper W2 from pins 1 and 2 of J14. The SCA input is bandpass filtered by C66, C14, R22, C15, C67, and R23 and is fed to the buffer amplifier U3A. The amplified signal

is then applied though the SCA gain pot R24 to the summing point at pin 13 of U2D.

4.1.1.4 Audio Modulation of the VCO

The balanced audio, or the composite audio and/or the SCA buffered audio signals, are fed to the common junction of resistors R14, R20, and R27 that connect to pin 13 of amplifier U2D. The output audio signal at pin 14 of U2D is typically .8 Vpk-pk at a ± 25 -kHz deviation for balanced audio or .8 Vpk-pk at ± 75 -kHz deviation for composite audio as measured at TP1. This signal is applied to the VCO U10. A sample of the deviation level is amplified, detected by U7A and U7B, and connected to J10 on the board. This audio deviation level is connected to the front panel meter through the transmitter control board.

The audio is connected to CR13 to CR16; these are varactor diodes that frequency modulate the audio signal onto the generated 4.5 MHz signal in U10. U10 is the 4.5 MHz VCO that generates the 4.5 MHz continuous wave (CW) signal. The output frequency of this signal is maintained and controlled by the correction voltage output of U5 PLL IC. The audio-modulated, 4.5 MHz signal is fed to amplifiers U11A and U11B. The output of U11B is connected to the 4.5 MHz output jacks at J7 and J8.

4.1.1.5 Phase Lock Loop (PLL) Circuit

A sample of the signal from the 4.5 MHz aural VCO at the output of U11A is applied to PLL IC U5 at the F_{in} connection. In U5, the signal is divided down to 50 kHz and is compared to a 50 kHz reference signal. The reference signal is a divided-down sample of the visual IF, 45.75 MHz signal that is applied to the oscillator input connection on the PLL chip through jack J6 on the board. These two 50 kHz signals are compared in the IC and the f_V and f_R is applied to the differential amplifier U3B. The output of U3B is fed back through CR17 to the

4.5 MHz VCO IC U10; this sets up a phase lock loop circuit. The 4.5 MHz VCO will maintain the extremely accurate 4.5 MHz separation between the visual and aural IF signals; any change in frequency will be corrected by the AFC error voltage.

PLL chip U5 also contains an internal lock detector that indicates the status of the PLL circuit. When U5 is in a "locked" state, pin 28 goes high and causes the green LED DS1 to illuminate. If the 4.5 MHz VCO and the 45.75 MHz oscillator become "unlocked," out of the capture range of the PLL circuit, pin 28 of U5 will go to a logic low and cause the red LED DS2 to light. A mute output signal from Q3 (unlock mute) will be applied to jack J9. This mute is connected to the transmitter control board.

4.1.1.6 Voltage Requirements

The ± 12 VDC needed for the operation of the board enters through jack J1. The +12 VDC is connected to J1-3 and filtered by L2, C3, and C4 before it is connected to the rest of the board. The -12 VDC is connected to J1-5 and filtered by L1, C1, and C2 before it is connected to the rest of the board. +12 VDC is connected to U8 and U9; these are 5 volt regulator ICs that provide the voltage to the U10 and U5 ICs.

4.1.2 (A5) Sync Tip Clamp/ Modulator Board (1265-1302; Appendix D)

The sync tip clamp/modulator board can be divided into five separate circuits: the main video circuit, the sync tip clamp circuit, the visual modulator circuit, the aural IF mixer circuit and the diplexer circuit.

The sync tip clamp/modulator board takes the baseband video or 4.5 MHz composite input that is connected to the video input jack (either J1 or J2, which are loop-through connected), and

produces a modulated visual IF + aural IF output at output jack J20 on the board. The clamp portion of the board maintains a constant peak of sync level over varying average picture levels (APL). The modulator portion of the board contains the circuitry that generates an amplitude-modulated vestigial sideband visual IF signal output that is made up of the baseband video input signal (1 Vpk-pk) modulated onto an externally generated 45.75 MHz IF carrier frequency. The visual IF signal and the aural IF signal are then combined in the diplexer circuit to produce the visual IF + aural IF output that is connected to J20, the IF output jack of the board.

4.1.2.1 Main Video Signal Path (Part 1 of 2)

The baseband video or the 4.5 MHz composite input connects to the board at J2. J2 is loop-through connected to J1 and terminated into 75Ω, if jumper W4 is on jack J3. With jumper W4 removed, the input can be connected to another transmitter through J1 that is loop-through connected to J2.

Test point TP1 is provided to monitor the level of the input. The input is fed to the non-inverting and inverting inputs of U1A, a differential amplifier that minimizes any common-mode hum that may be present on the incoming signal. Diodes CR1 to CR4 form a voltage-limiter network in which, if the input voltages exceed the supply voltages for U1A, the diodes conduct, preventing damage to U1A. CR1 and CR3 conduct if the input voltage exceeds the negative supply and CR2 and CR4 conduct if the input voltage exceeds the positive supply voltage.

The video output of U1A is connected to J22 on the board. Normally, the video at J22 is jumpered to J27 on the board. If the 4.5 MHz composite input kit is purchased, the 4.5-MHz composite signal at J22 connects to the external composite 4.5 MHz filter board and the 4.5 MHz

bandpass filter board. These two boards provide the video-only signal to J27 and the 4.5 MHz intercarrier signal to J28 from the 4.5 MHz composite input. The video through the video gain pot R12 (adjusted for 1 Vpk-pk at TP2) connects to amplifier U1B.

The output of U1B, if the delay equalizer board is present in the tray, connects the video from J6, pin 2, to the external delay equalizer board and back to the sync tip clamp/modulator board at J6, pin 4. If the delay equalizer is not present, the video connects through jumper W1 on J5, pins 1 and 2. The delay equalizer board plugs directly to J6 on the sync tip clamp/modulator board. The video from J6, pin 4, is then connected through jumper W1 on J5, pins 2 and 3, to the amplifier Q1. The output of Q1 connects to Q2; the base voltage of Q2 is set by the DC offset voltage output of the sync tip clamp circuit.

4.1.2.2 Sync Tip Clamp Circuit

The automatic sync tip clamp circuit is made up of U4A, Q7, U3B, and associated components. The circuit begins with a sample of the clamped video that is split off from the main video path at the emitter of Q3. The video sample is buffered by U3A and connected to U4A. The level at which the tip of sync is clamped, approximately -1.04 VDC as measured at TP2, is set by the voltage-divider network connected to U4A. If the video level changes, the sample applied to U4A changes. If jumper W7 on J4 is in the Clamp-On position, the voltage from the clamp circuit that is applied to the summing circuit at the base of Q2 will change; this will bring the sync tip level back to approximately -1.04 VDC. Q7 will be turned off and on according to the peak of sync voltage level that is applied to U4A. The capacitors C14, C51, C77, and C41 will charge or discharge to the new voltage level, which biases U3B more or less, through jumper W7 on J4 in the Auto Clamp-On position. U3 will

increase or decrease its output, as needed, to bring the peak of sync back to the correct level as set by R152 and R12. This voltage level is applied through U3B to Q2. In the Manual position, jumper W7 on J4 is in the Clamp-Off position, between pins 1 and 2, and adjustable resistor R41 provides the manual clamp bias adjustment for the video that connects to Q2.

Jumper W6 on jack J35 must be in the Normal position, between pins 2 and 3, for the clamp circuit to operate with a normal non-scrambled signal. If a scrambled signal is used, the tray is operated with jumper W6 in the Encoded position, connected between pins 1 and 2. The clamp circuit is set by adjusting depth of modulation pot R152 for the correct depth of modulation as measured at TP2.

Depending on the input video level, the waveform as measured at TP2 may not be 1 Vpk-pk. If W7 on J4 is moved to the Clamp-Off (Manual) position, between pins 1 and 2, the clamp level is adjusted by R41 and will not automatically be clamped to the set level. The output of buffer amplifier U3A drives the sync tip clamp circuit consisting of differential amplifier U4A, FET Q7, and buffer amplifier U3B. U4A is biased by R124, R125, R184, R152, and R126 so that the clamped voltage level at peak of sync is approximately -1.04 VDC as measured at TP2.

4.1.2.3 Main Video Signal Path (Part 2 of 2)

The clamped video from Q2 is connected to white clipper circuit Q3. Q3 is adjusted with R20 and set to prevent video transients from overmodulating the video carrier. The clamped video is connected to sync clipper circuit Q4 (adjusted by R24); Q4 limits the sync to -40 IRE units. The corrected video connects to emitter follower Q4 whose output is wired to unity gain amplifier U2A and provides a

low-impedance, clamped video output at pin 1.

4.1.2.4 Visual Modulator Circuit

The clamped video signal from U2A is split. One part connects to a metering circuit, consisting of U20 and associated components, that produces a video output sample at J8-6 and connects through the transmitter control board to the front panel meter for monitoring. The other clamped video path from U2A is through a sync-stretch circuit that consists of Q5 and Q6. The sync-stretch circuit contains R48; R48 adjusts the sync stretch magnitude (amount) and R45 adjusts the cut-in. This sync-stretch adjustment should not be used to correct for output sync problems, but it can be used for video input sync problems. The output of the sync-stretch circuit connects to pin 5, the I input of mixer Z1.

The video signal is heterodyned in mixer Z1 with the visual IF CW signal (45.75 MHz). The visual IF CW signal enters the board at jack J15 and is connected to U9, where it is amplified and wired to pin 1, the L input of mixer Z1. The adjustable capacitor C78 and resistor R53 are set up to add a small amount of incidental carrier phase modulation (ICPM) correction to the output of the mixer stage to compensate for any non-linearities generated by the mixer.

The modulated 45.75 MHz RF output of mixer Z1 is amplified by U5 and is fed to double-sideband visual IF output jack J18. The level of this output jack is adjusted by R70. J18 is the visual IF loop-through output jack that is normally jumpered to J19 on the board. If the optional visual IF loop-through kit is purchased, the visual is connected out of the board to any external IF processor trays.

After any external processing, the modulated visual IF, double-sideband signal re-enters the board through J19.

The visual IF from J19 is amplified by U10 and U11 and routed through the vestigial sideband filter network, consisting of T1, FL1, and T2, and produces a vestigial sideband visual IF signal output. The filtered vestigial sideband visual IF is amplified by U7 and connected to a T-type attenuator. R62 can be adjusted to set the visual IF gain; this is the amount of visual IF signal that is coupled to amplifier IC U8. R63 and C30 are adjusted for the best VSBF frequency response. The amplified IF signal is fed to the input of the diplexer circuit that consists of R76, L13, and L12. A detected voltage sample of the visual IF is available at test point TP5.

4.1.2.5 41.25 MHz Aural IF Circuit

On this board, the 41.25 MHz aural IF is created by mixing the modulated 4.5 MHz aural intercarrier signal, produced by the aural IF synthesizer board or from the composite 4.5 MHz filter board, with the 45.75 MHz CW signal produced by the 45.75 MHz IF carrier oven oscillator board. The modulated 4.5 MHz aural intercarrier signal enters the board at J14 or J28 and is connected to IF relay K1. Jumper W3 on J7 determines whether the 4.5 MHz used by the board is internally generated or from an external source. With jumper W3 connected between pins 2 and 3, the 4.5 MHz from the aural IF synthesizer board or from the 4.5 MHz composite input is connected to mixer Z2. If an external 4.5 MHz signal is used, it enters the board at J12 and is fed through gain pot R88 to amplifier IC U13A. The amplified 4.5 MHz is then connected to J7 and, if jumper W3 is between pins 1 and 2, the 4.5 MHz signal from the external source is connected to the mixer. Mixer Z2 heterodynes the aural-modulated, 4.5 MHz signal with the 45.75 MHz CW signal to produce the modulated 41.25 MHz aural IF signal.

The output of the mixer is fed to a bandpass filter that is tuned to pass only the modulated 41.25 MHz aural IF signal

that is fed to jack J16, the 41.25 MHz loop-through out jack of the board.

For normal operation, the 41.25 MHz signal is jumpered by a coaxial cable from J16 to J17 on the board. If the (optional) aural IF loop-through kit is purchased, the 41.25 MHz signal is connected to the rear of the tray, to which any processing trays can be connected, and then back to jack J17 on the board. The modulated 41.25 MHz aural IF signal from J17 is connected through amplifier ICs U15 and U16. The amplified output is connected to the attenuator-matching circuit that is adjusted by R85. R85 increases or decreases the level of the 41.25 MHz that sets the A/V ratio for the diplexer circuit. The diplexer circuit takes the modulated 45.75 MHz visual IF and the modulated aural IF and combines them to produce the 45.75 MHz + 41.25 MHz IF output. The combined 45.75 MHz + 41.25 MHz IF signal is amplified by U12 and connected to combined IF output jack J20 on the board. A sample of the combined IF output is provided at J21 on the board. If a NICAM input is used, it connects to J36 on the board. The level of the NICAM signal is set by R109 before it is fed to the diplexer circuit consisting of L28, L29, and R115. This circuit combines the NICAM signal with the 45.75 MHz visual IF + 41.25 MHz aural IF signal.

4.1.2.6 Operational Voltages

The +12 VDC needed to operate the transmitter control board enters the board at J23, pin 3, and is filtered by L26, L33, and C73 before it is fed to the rest of the board.

The -12 VDC needed to operate the board enters the board at J23, pin 5, and is filtered by L27 and C74 before being fed to the rest of the board.

4.1.3 (A6) Delay Equalizer Board (1227-1204; Appendix D)

The delay equalizer board provides a delay to the video signal, correction to the frequency response, and amplification of the video signal.

The video signal enters the board at J1-2 and is connected to a pi-type, low-pass filter consisting of C16, L7, and C17. This filter eliminates any unwanted higher frequencies from entering the board. The output of the filter is connected to amplifier stage U1; the gain is controlled by R29. The video output of the amplifier stage is wired to the first of four delay-equalizing circuits that shape the video signal to the FCC specification for delay equalization or to the desired shape needed for the system. The board has been factory-adjusted to this FCC specification and should not be readjusted without the proper equipment.

Resistors R7, R12, R17, and R22 adjust the sharpness of the response curve while inductors L1, L2, L3, and L4 adjust the position of the curve. With a delay equalizer test generator signal or a sine wave video test pattern input, the resistors and inductors can be adjusted, while monitoring a Tektronix VM700 test measurement set, until the desired FCC delay equalization curve or system curve is attained. The delay-equalized video signal is connected to J1-4, the video output of the board. A sample of the delayed video signal is connected to J2 on the board and can be used for testing purposes.

The ± 12 VDC needed to operate the board enters the board at J1. The +12 VDC connects to J1-9, which is filtered by L5 and C11 before it is directed to the rest of the board. The -12 VDC connects to J1-6, which is filtered by L6 and C12 before it is directed to the rest of the board.

4.1.4 (A7) IF Carrier Oven Oscillator Board (1191-1404; Appendix D)

The IF carrier oven oscillator board generates the visual IF CW signal at 45.75 MHz for NTSC system "M" usage. The +12 VDC is applied through jack J10 to crystal oven HR1, which is preset to operate at 60° C. The oven encloses crystal Y1 and stabilizes the crystal temperature. The crystal is the principal device that determines the operating frequency and is the most sensitive in terms of temperature stability.

Crystal Y1 operates in an oscillator circuit consisting of transistor Q1 and its associated components. Feedback is provided through a capacitor-voltage divider, consisting of C5 and C6, that connects to the crystal mounted in a common-base amplifier configuration using Q1. The operating frequency of the oscillator can be adjusted by variable capacitor C17. The oscillator circuit around Q1 has a separate regulated voltage, +6.8 VDC, which is produced by a combination of dropping resistor R4 and zener diode VR1. The output of the oscillator at the collector of Q1 is capacitively coupled through C8 to the base of Q2. The small value of C8, 10 pF, keeps the oscillator from being loaded down by Q2.

Q2 is operated as a common-emitter amplifier stage whose bias is provided through R8 from the +12 VDC line. The output of Q2, at its collector, is split between two emitter-follower transistor stages, Q3 and Q4. The output of Q3 is taken from its emitter through R11 to establish an approximate 500 source impedance through C11 to J3, the main output jack. This 45.75 MHz signal is at about the +5 dBm power level. In most systems, this output is either directed to a visual modulator board or to some splitting and amplifying arrangement that distributes the visual IF carrier for other needs. The second output from the collector of Q2 is fed to the base of Q4, the emitter follower transistor.

Q4 drives two different output circuits. One output is directed through voltage dividers R14 and R15 to jack J2 that can connect to a frequency counter. While monitoring J2 the oscillator can be set exactly on the operating frequency (45.75 MHz) by adjusting C17. The output at J2 is at a power level of approximately -2 dBm, which is sufficient to drive most frequency counters. The other output of Q4 connects to prescaler chip U1, which divides the signal by 15. The output of U1 is applied to U2, a programmable divider IC. U2 is programmed through pins 11 to 20 to divide by 61. This results in a 50-kHz signal at pin 9 that is available as an output at J1. The output of 50 kHz is generally used in systems where the visual IF carrier oven oscillator is used as the reference for a PLL circuit. An example of this is when the PLL circuit uses the aural IF synthesizer board and the aural VCO. The 50 kHz CMOS output at jack J1 is not capable of achieving enough drive level for a long coaxial cable length. As a result, when a long coaxial cable is needed, the output at jack J5 is utilized. The push-pull transistor stage Q5 and Q6, along with emitter resistor R18, provide a large-load output capability at J5.

The stages U1, U2, Q5, and Q6 are powered by +5.1 VDC, which is obtained using the +12 VDC line voltage, the voltage-dropping resistor R16 and the Zener diode VR2.

The +12 VDC power is applied to the board through jack J4, pin 3, and is isolated from the RF signals that may occur in the +12 VDC line through the use of RF choke L2 and filter capacitor C10.

4.1.5 (A8) ALC Board, NTSC (1265-1305; Appendix D)

The automatic level control (ALC) board provides the ALC and amplitude linearity correction of the IF signal. The ALC adjusts the level of the IF signal through

the board to control the output power of the transmitter.

The visual + aural IF input signal, (0 dBm), from the modulator enters the board at the modulator IF input jack J32. If the (optional) receiver tray is present, the visual + aural IF input, (0 dBm), from the receiver tray connects to the receiver IF input jack J1. The modulator IF input connects to relay K3 and the receiver IF input connects to relay K4. The two relays are controlled by the Modulator Select command that is connected to J30 on the board. Modulator select enable/disable jumper W11 on J29 controls whether the Modulator Select command at J30 controls the operation of the relays or not. With jumper W11 on J29, pins 1 and 2, the Modulator Select command at J30 controls the operation of the relays; with jumper W11 on J29, pins 2 and 3, the modulator is selected all of the time. This is the normal position.

4.1.5.1 Modulator Selected

With the modulator selected, J9-31 & J9-32 located on the A/V I/P & Remote Interface Assembly are connected together; this makes J30 low and causes relays K3 and K4 to de-energize. When K4 is de-energized, it connects the receiver IF input at J1, if present, to 500. When K3 is de-energized, it connects the modulator IF input at J32 to the rest of the board; Modulator Enable LED DS5 will be illuminated.

4.1.5.2 (Optional) Receiver Selected

With the (Optional) receiver selected, which is J9-31 & J9-32 located on the (A12) A/V I/P & Remote Interface Assembly (connected to J30 on the board), not connected together, relays K3 and K4 are energized. When K4 is energized, it connects the receiver IF input at J1, if present, to the rest of the board. When K3 is energized, it connects to the modulator IF input at J32 to 500. The Modulator Enable LED DS5 will be illuminated.

4.1.5.3 Main IF Signal Path (Part 1 of 3)

The selected visual + aural IF input (0 dBm) signal is split, with one half of the signal entering a bandpass filter that consists of L3, L4, C4, L5, and L6. This bandpass filter can be tuned with C4 and is substantially broader than the IF signal bandwidth. It is used to slightly steer the frequency response of the IF to make up for any small discrepancies in the frequency response in the stages that precede this point. The filter also serves the additional function of rejecting unwanted frequencies that may occur if the tray cover is off and the tray is in a high RF environment. If this is the case, the transmitter will have to be serviced with the tray cover off in spite of the presence of other RF signals. The filtered IF signal is fed through a pi-type matching pad consisting of R2, R3, and R4 to the pin-diode attenuator circuit consisting of CR1, CR2, and CR3.

4.1.5.4 Input Level Detector Circuit

The other part of the split IF input is connected through L2 and C44 to U7; U7 is an IC amplifier that is the input to the input level detector circuit. The amplified IF is fed to T4; T4 is a step-up transformer that feeds diode detector CR14. The positive-going detected signal is then low-pass filtered by C49, L18, and C50. This allows only the video with positive sync to be applied through emitter follower Q1. The signal is then connected to detector CR15 to produce a peak-sync voltage that is applied to op-amp U9A. There is a test point at TP3 that provides a voltage reference check of the input level. The detector serves the dual function of providing a reference that determines the input IF signal level to the board and also serves as an input threshold detector.

The input threshold detector prevents the automatic level control from reducing the attenuation of the pin-diode attenuator to minimum (the maximum signal) if the IF input to the board is removed. The ALC,

video loss cutback, and the threshold detector circuits will only operate when jumper W3 on jack J6 is in the Auto position, between pins 1 and 2. Without the threshold detector, and with the pin-diode attenuator at minimum, when the signal is restored it will overdrive the stages following this board.

As part of the threshold detector operation, the minimum IF input level at TP3 is fed through detector CR15 to op-amp IC U9A, pin 2. The reference voltage for the op-amp is determined by the voltage divider that consists of R50 and R51 (off the +12 VDC line). When the detected-input signal level at U9A, pin 2, falls below this reference threshold (approximately 10 dB below the normal input level), the output of U9A at pin 1 goes to the +12 VDC rail. This high is connected to the base of Q2. At this point, Q2 is forward biased and creates a current path from the -12 VDC line and through red LED DS1, the input level fault indicator, which becomes lit, resistor R54, and transistor Q2 to +12 VDC. The high from U9A also connects through diode CR16 to U9B, pin 5, whose output at pin 7 goes high. The high connects through range adjust pot R74 to J20, which connects to the front panel-mounted power adjust pot. This high connects to U10A, pin 2, and causes it to go low at output U10A, pin 1. The low is applied through jumper W3 on J6 to the pin-diode attenuator circuit that cuts back the IF level and, therefore, the output power level, to 0. When the input signal level increases above the threshold level, the output power will raise, as the input level increases, until normal output power is reached.

The video input level at TP3 is also fed to a sync-separator circuit, consisting of IC U8, CR17, Q3, and associated components, and then to a comparator circuit made up of U9C and U9D. The reference voltage for the comparators is determined by a voltage divider consisting of R129, R64, R65, R66, and R130 (off the -12 VDC line). When the

input signal level to the detector at TP3 falls below this reference threshold, which acts as a loss of sync detector circuit, the output of U9C and U9D goes towards the -12 VDC rail and is split, with one part biasing on transistor Q5. A current path is then established from the +12 VDC line through Q5, the resistors R69, R137, and the red LED DS3 (video loss indicator), which becomes lit. When Q5 is on, it applies a high to the gates of Q6 and Q7. This causes them to conduct and apply video loss fault pull-down outputs to J18, pins 5 and 2.

The other low output of U9C and U9D is connected through CR20 to jack J5. Jumper W2 on J5, in the Cutback Enable position (between pins 2 and 3), connects the low to the base of the forward-biased Q4. If jumper W2 is in the Disable position, between pins 1 and 2, the auto cutback will not operate. With Q4 biased on, a level determined by the setting of cutback level pot R71, which is set at the factory to cut back the output to approximately 25%, is applied to U9B, pin 5. The output of U9B at pin 7 goes low and is applied through the power adjust pot to U10A, pin 2, whose output goes low. This low is applied to the pin-diode attenuator to cut back the level of the output to approximately 25%.

4.1.5.5 Pin-Diode Attenuator Circuit

The input IF signal is fed to a pin-diode attenuator circuit that consists of CR1 to CR3. Each of the pin diodes contain a wide intrinsic region; this makes the diodes function as voltage-variable resistors at this intermediate frequency. The value of the resistance is controlled by the DC bias supplied to the diode. The pin diodes are configured in a pi-type attenuator configuration where CR1 is the first shunt element, CR3 is the series element, and CR2 is the second shunt element. The control voltage, which can be measured at TP1, originates either from the ALC circuit when jumper W3 on J6 is in the ALC Auto position, between

pins 1 and 2, or from pot R87 when the jumper is in the Manual Gain position.

On the pin-diode attenuator circuit, a current path exists from J6 through R6 and then through the diodes of the pin attenuator. Changing the amount of current through the diodes by forward biasing them changes the IF output level of the board. There are two extremes of attenuation ranges for the pin-diode attenuators. In the minimum attenuation case, the voltage, measured at TP1, approaches the +12 VDC line. There is a current path created through R6, through series diode CR3, and finally through R9 to ground. This path forward biases CR3 and causes it to act as a relatively low-value resistor. In addition, the larger current flow increases the voltage drop across R9 that tends to turn off diodes CR1 and CR2 and causes them to act as high-value resistors. In this case, the shunt elements act as a high resistance and the series element acts as a low resistance to represent the minimum loss condition of the attenuator (maximum signal output). The other extreme case occurs as the voltage at TP1 is reduced and goes towards ground or even slightly negative. This tends to turn off (reverse bias) diode CR3, the series element, causing it to act as a high-value resistor. An existing fixed current path from the +12 VDC line, and through R5, CR1, CR2, and R9, biases series element CR3 off and shunt elements, diodes CR1 and CR2 on, causing them to act as relatively low-value resistors. This represents the maximum attenuation case of the pin attenuator (minimum signal output). By controlling the value of the voltage applied to the pin diodes, the IF signal level is maintained at the set level.

4.1.5.6 Main IF Signal Path (Part 2 of 3)

When the IF signal passes out of the pin-diode attenuator through C11, it is applied to modular amplifier U1. This device includes within it the biasing and impedance matching circuits that makes it operate as a wide-band IF amplifier.

The output of U1 is available, as a sample of the pre-correction IF for troubleshooting purposes and system setup, at jack J2. The IF signal is then connected to the linearity corrector portion of the board.

4.1.5.7 Linearity Corrector Circuits

The linearity corrector circuits use three stages of correction to correct for any amplitude non-linearities of the IF signal. Each stage has a variable threshold control adjustment, R34, R37, or R40, and a variable magnitude control adjustment, R13, R18, or R23. The threshold control determines the point at which the gain is changed and the magnitude control determines the amount of gain change that occurs once the breakpoint is reached. Two reference voltages are needed for the operation of the corrector circuits. Zener diode VR1, with R33 and R135, provides a +6.8 VDC reference and the diodes CR11 and CR12 provide a .9 VDC reference that temperature compensates for the two diodes in each corrector stage.

For the linearity correctors to operate, an IF signal is applied to transformer T1, which doubles the voltage swing by means of a 1:4 impedance transformation. Resistors R14, R15, and R16 form an L-pad that lowers the level of the signal. The amount that the level is lowered is adjusted by adding more or less resistance, using R13, in parallel with the L-pad resistors. R13 is only in parallel when the signal reaches a level large enough to turn on the diodes CR4 and CR5. When the diodes turn on, current flows through R13, putting it in parallel with the L-pad.

When R13 is put in parallel with the resistors, the attenuation through the L-pad is lowered, causing signal stretch (the amount determined by the adjustment of R13). The signal is next applied to amplifier U2 to compensate for the loss through the L-pad. The breakpoint, or cut-in point, for the first

corrector is set by controlling where CR4 and CR5 turn on. This is accomplished by adjusting cut-in resistor R34; R34 forms a voltage-divider network from +6.8 VDC to ground. The voltage at the wiper arm of R34 is buffered by unity-gain amplifier U5D. This reference voltage is then applied to R35, R36, and C39 through L12 to the CR4 diode. C39 keeps the reference from sagging during the vertical interval. The .9 VDC reference created by CR11 and CR12 is applied to unity-gain amplifier U5B. The reference voltage is then connected to diode CR5 through choke L11. The two chokes L11 and L12 form a high impedance for RF that serves to isolate the op-amp ICs from the IF.

After the signal is amplified by U2, it is applied to the second corrector stage through T2. This corrector and the third corrector operate in the same fashion as the first. All three corrector stages are independent and do not interact with each other.

The correctors can be disabled by moving jumper W1 on J4 to the Disable position, between pins 2 and 3; this moves all of the breakpoints past the tip of sync so that they will have no affect. The IF signal exits the board at IF output jack J3 after passing through the three corrector stages and is normally connected to an external IF phase corrector board.

4.1.5.8 Main IF Signal Path (Part 3 of 3)

After the IF signal passes through the external IF phase corrector board, it returns to the ALC board at IF input jack J7. The IF then passes through a bandpass filter consisting of L20, C97, C62, L21, C63, L22, L23, C64, and C99. This bandpass filter is identical in both form and function to the one described in Section 3.3 of this chapter. In this case, the filter is intended to make up for small errors in frequency response that are incurred by the signal while being processed through the linearity and incidental phase correction circuits.

Following the bandpass filter, the signal is split using L24, L25, and R89. The signal passing through L24 is the main IF path through the board. A sample of the corrected IF signal is split off and connected to the IF sample jack J10. The IF connects to jacks J27 and J28. These jacks control whether a 6 dB pad is included in the circuit by the positioning of jumpers W9 and W10. The 6 dB pad-in is when jumpers W9 and W10 are connected between pins 2 and 3 on J27 and J28. The 6 dB pad-out is when jumpers W9 and W10 are connected between pins 1 and 2 on J27 and J28. Normally, the pad is out. The IF signal is then applied to a two-stage, frequency-response corrector circuit that is adjusted as needed.

Variable resistors R103 and R106 adjust the depth and gain of the notches and variable caps C71 and C72 adjust the frequency position of the notches. The IF signal is amplified by U13 and U14 before it is connected to J12, the IF output jack of the board. R99 is an output level adjustment that is set to provide approximately 0 dBm of IF output at J12. A sample of the IF is fed to J11 to provide an IF sample point that can be monitored without breaking the signal path and gives an indication of the IF signal after the linearity and the frequency-response correction takes place.

4.1.5.9 ALC Circuit

The other path of the corrected IF signal is used in the ALC circuit. The IF is wired out of the splitter through L25 and connects to op-amp U12. The output of U12 is wired to jacks J8 and J9 on which jumpers W4 and W8 control the normal or encoded operation of the ALC circuitry. For normal operation, jumper W4 on J8 is between pins 1 and 2 and jumper W8 on J9 is between pins 1 and 2. The IF signal is applied to transformer T5; T5 doubles the voltage swing by means of a 1:4 impedance transformation before it is

connected to the ALC detector circuit on the board and amplified by U10B.

For normal operation, jumper W7 on J26 is between pins 1 and 2 and jumper W5 on J21 is between pins 1 and 2. The detected ALC voltage is wired to U10A, pin 2, where it is summed with the front panel power control setting. The output power adjustment for the transmitter is achieved, if the (optional) remote power raise/lower kit (1227-1039) is purchased, by R75, a motor-driven pot controlled by switch S1 on the board, or screwdriver adjust pot R1 on the front panel of the UHF exciter tray. An external power raise/lower switch can be used by connecting it to jack J9, at J9-27 power raise, J9-28 power raise/lower return, and J9-29 power lower, on (A12) the A/V I/P & Remote Interface Assembly. S1, or the remote switch, controls relays K1 and K2, which control motor M1 that moves variable resistor R75. If the (optional) remote power raise/lower kit is not purchased, the ALC voltage is controlled only by screwdriver adjust pot R1 on the front panel of the UHF exciter tray. The ALC voltage is set for .8 VDC at TP4 with a 0 dBm output at J12 of the board. A sample of the ALC at J19, pin 2, is wired to the transmitter control board where it is used on the front panel meter and in the AGC circuits.

This ALC voltage, and the DC level corresponding to the IF level after signal correction, are fed to U10A, pin 2, whose output at pin 1 connects to the ALC pin-diode attenuator circuit. If there is a loss of gain somewhere in an IF circuit, the output power of the transmitter will drop. The ALC circuit senses this drop at U10A and automatically lowers the loss of the pin-diode attenuator circuit to compensate by increasing the gain.

The ALC action starts with the ALC detector level that is monitored at TP4. The detector output at TP4 is nominally +.8 VDC and is applied through resistor R77 to a summing point at op-amp U10A, pin 2. The current available from

the ALC detector is offset, or complemented, by current taken away from the summing junction. In normal operation, U10A, pin 2, is at 0 VDC when the loop is satisfied. If the recovered or peak-detected IF signal at IF input jack J7 of this board should drop in level, which normally means that the output power is decreasing, the null condition would no longer occur at U10A, pin 2. When the level drops, the output of U10A, pin 1, will go more positive. If jumper W3 on J6 is in the Automatic position, it will cause the ALC pin-diode attenuators CR1, CR2, and CR3 to have less attenuation and increase the IF level; this will act to compensate for the decrease in level. If the ALC cannot increase the input level enough to satisfy the ALC loop, because of not enough range, an ALC fault will occur. The fault is generated because U10D, pin 12, increases above the trip point set by R84 and R83 until it conducts. This makes U10D, pin 14, high and causes the red ALC Fault LED DS2 to light.

4.1.5.10 Scrambled Operation with Encoding

For encoded, scrambled operation, jumper W4 on J8 must be connected between pins 2 and 3, jumper W8 on J9 must be between pins 3 and 2, jumper W7 on J26 must be between pins 2 and 3, and jumper W5 on J21 must be between pins 2 and 3. The IF is connected through W4 on J8 to the sync regeneration circuits.

If this board is operated with scrambling, using suppressed sync, the ALC circuit operates differently than described above because there is no peak of sync present on the IF input. A timing pulse from the scrambling encoder connects to the board at J24. This timing pulse is converted to sync pulses by U17A and U17B, which control the operation of Q8. The sync amplitude is controlled by R149 and is then applied to U15A, where it is added to the detected IF signal to produce a peak of sync level. The output

of U15A is peak detected by CR26 and fed to U15B. If necessary, intercarrier notch L39 can be placed in the circuit by placing W6 on J22. The intercarrier notch is adjusted to filter any aural and 4.5-MHz intercarrier frequencies. The peak of sync signal is fed through R162, the ALC calibration control, to amplifier U15C. The amplified peak of sync output is connected through J21, pins 2 and 3, to U10A, where it is used as the reference for the ALC circuit and the AGC reference to the transmitter control board. Voltage TP4 should be the same in either the normal or the encoded video mode. Monitor J9, pins 3 and 4, with a spectrum analyzer, check that the board is in the AGC mode, and tune C103 to notch-out the aural IF carrier.

4.1.5.11 Fault Command

The ALC board also has circuitry for an external mute fault input at J19, pin 6. This is a Mute command and, in most systems, it is involved in the protection of the circuits of high-gain output amplifier devices. The Mute command is intended to protect the amplifier devices against VSWR faults. In this case, the action should occur faster than just pulling the ALC reference down. Two different mechanisms are employed: one is a very fast-acting circuit to increase the attenuation of the pin-diode attenuator, CR3, CR1, and CR2, and the second is the reference voltage being pulled away from the ALC amplifier device. An external Mute is a pull-down applied to J19, pin 6, to provide a current path from the +12 VDC line through R78 and R139, the LED DS4 (Mute indicator), and the LED section of opto-isolator U11.

These actions turn on the transistor section of U11 that applies -12 VDC through CR21 to U10A, pin 3, and pulls down the reference voltage. This is a fairly slow action that is kept at this pace by the low-pass filter function of R81 and C61. When the transistor section of U11 is on, -12 VDC is also connected through CR22 to the pin-diode attenuator circuit.

This establishes a very fast muting action, by reverse biasing CR3, in the event of an external VSWR fault.

4.1.5.12 ± 12 VDC Needed to Operate the Board

The ± 12 VDC connects to the board at J14. The +12 VDC connects to J14-3 and is filtered by L30, L41, and C80 before it is applied to the rest of the board. The -12 VDC connects to J14-5 and is filtered by L31 and C81 before it is applied to the rest of the board.

The +12 VDC also connects to U16, a 5-VDC regulator IC, that produces the +5 VDC needed to operate timing IC U17.

4.1.6 (A9) IF Phase Corrector Board (1227-1250; Appendix D)

The IF phase corrector board has adjustments that pre-correct for any IF phase modulation distortion that may occur in output amplifier devices such as Klystron power tubes and solid-state amplifiers. Two separate, adjustable IF paths are on the board: a quadrature IF path and an in-phase IF path. The quadrature IF is 90° out of phase and much larger in amplitude than the in-phase IF. When they are combined in Z1, it provides the required adjustable phase correction to the IF signal.

The IF input signal enters at J1 and is AC coupled to U1. U1 amplifies the IF before it is connected to Z1, a splitter that creates two equal IF outputs: IF output 1 is connected to J2 and IF output 2 is connected to J3. The IF output 1 at J2, is jumpered through coaxial cable W4 to jack J6, the quadrature input on the board. The IF output 2 at J3, is jumpered through coaxial cable W5 to jack J7, the in-phase input on the board.

4.1.6.1 Phase Corrector Circuit

The phase corrector circuit corrects for any amplitude nonlinearities of the IF signal. It is designed to work at IF and

has three stages of correction. Each stage has a variable threshold and magnitude control. The threshold control determines the point at which the gain is changed and the magnitude control determines the gain change once the breakpoint is reached. The second stage has a jumper that determines the direction of correction, so that the gain can increase either above or below the threshold, and either black or white stretch can be achieved.

In the phase corrector circuit, the IF signal from J6 is applied to transformer T1; T1 doubles the voltage swing using a 1:4 impedance transformation. Resistors R8, R61, R9, and R48 form an L-pad that attenuates the signal. This attenuation is adjusted by adding R7, a variable resistor, in parallel with the L-pad. R7 is only in parallel when the signal reaches a level large enough to bias on CR1 and CR2 and allow current to flow through R7. When R7 is put in parallel with the L-pad, the attenuation through the L-pad is lowered, causing black stretch.

Two reference voltages are utilized in the corrector stages and both are derived from the +12 VDC line. Zener diode VR1, with R46 as a dropping resistor, provides +6.8 VDC from the +12 VDC line. Diodes CR11 and CR12 provide a .9 VDC reference to temperature compensate the corrector circuits from the effects of the two diodes in each corrector stage.

The threshold for the first corrector stage is set by controlling where the diodes CR1 and CR2 turn on. This is accomplished by adjusting R3 to form a voltage divider from +6.8 VDC to ground. The voltage at the wiper of R3 is buffered by U9C, a unity-gain amplifier, and applied to CR1. The .9 VDC reference is connected to U9D, a unity-gain amplifier, whose output is wired to CR2. These two references are connected to diodes CR1 and CR2 through chokes L2 and L3. The two chokes form a high impedance for RF to isolate the op-amps from the RF. The adjusted signal is next applied to

amplifier U2 to compensate for the loss through the L-pad. U2 is powered through L4 and R10 from the +12 VDC line. After the signal is amplified by U2, it is applied to the second corrector stage through T2 and then to a third corrector stage through T3. The other two corrector stages operate in the same manner as the first; they are independent and do not interact with each other.

When jumper W1 on J8 is connected from center to ground, R15 is put in series with ground. In this configuration, black stretch (white compression) is applied to the IF signal by controlling the attenuation through the path. When W1 is connected from the center pin to the end that connects to T2, R15 is put in parallel with the L-pad. In this configuration, black compression (white stretch) is applied to the IF signal by controlling the attenuation through the path.

The phase correctors can be bypassed by moving jumper W2 on J9 to the Disable position. This action will move all of the threshold points past sync tip so that they will have no effect. R68 can be adjusted and set for the correction range that is needed. TP2 is a test point that gives the operator a place to measure the level of the quadrature IF signal that is connected to pin 6 on combiner Z2.

4.1.6.2 Amplitude Corrector Circuit

The amplitude corrector circuit uses one stage of correction to correct for any amplitude nonlinearities of the IF signal. The stage has a variable threshold control, R31, and a variable magnitude control, R35. The threshold control determines the point at which the gain is changed and the magnitude control determines the amount of gain change once the breakpoint is reached.

Two reference voltages are needed for the operation of the corrector circuit. Zener diode VR1 with R46 provides +6.8

VDC and the diodes CR11 and CR12 provide a .9 VDC reference voltage to temperature compensate for the two diodes in the corrector stage. In the amplitude corrector circuit, the IF signal from J7 is applied to transformer T4 to double the voltage swing by means of a 1:4 impedance transformation. Resistors R36, R55, R56, and R37 form an L-pad that lowers the level of the signal. The amount that the level is lowered is adjusted by adding more, or less, resistance, using R35 in parallel with the L-pad resistors. R35 is only in parallel when the signal reaches a level large enough to turn on diodes CR8 and CR9. When the diodes turn on, current flows through R35 and puts it in parallel with the L-pad. When R35 is in parallel with the resistors, the attenuation through the L-pad is lowered, causing signal stretch. The amount of stretch is determined by the adjustment of R35.

The signal is next applied to amplifier U5 to compensate for the loss in level through the L-pad. The breakpoint, or cut-in point, for the corrector stage is set by controlling where CR8 and CR9 turn on. This is achieved by adjusting cut-in resistor R31 to form a voltage divider from +6.8 VDC to ground. The voltage at the wiper arm of R31 is buffered by the unity-gain amplifier U8B. This voltage is then applied to R34 through L11 to the CR9 diode. The .9 VDC reference created by CR11 and CR12 is applied to unity-gain amplifier U8A. C36 keeps the reference from sagging during the vertical interval. The reference voltage is then connected to diode CR8 through choke L12. The two chokes L11 and L12 form a high impedance for RF to isolate the op-amp ICs from the IF.

After the signal is amplified by U5, it is applied to a second stage through T5. The transformer doubles the voltage swing by means of a 1:4 impedance transformation. Resistors R39, R57, R58, and R40 form an L-pad that lowers the level of the signal. The signal is applied to amplifier U6 to compensate for the

loss in level through the L-pad. After the signal is amplified by U6, it is applied to a third stage through T6. The transformer doubles the voltage swing by means of a 1:4 impedance transformation. Resistors R42, R59, R60, and R43 form an L-pad to lower the level of the signal. The signal is applied to amplifier U7 to compensate for the loss in level through the L-pad. TP1 is a test point that gives the operator a place to measure the level of the in-phase IF signal that is connected to mixer stage Z2. The amplitude corrector can be disabled by moving the jumper W3 on J10, to the Disable position. This will move the breakpoint past sync tip and will have no effect on the signal.

4.1.6.3 Output Circuit

The phase-corrected signal from pin 1 on combiner Z2 exits the board at the IF output jack J4, after passing through a matching network consisting of six resistors.

4.1.7 (A11) VHF Mixer/Amplifier Enclosure Assembly (1088067; Appendix C)

The VHF mixer/amplifier enclosure assembly is made up of the x4 multiplier board, the VHF filter/mixer board, and the VHF high band filter/amplifier board.

4.1.7.1 (A11-A1) x4 Multiplier Board (1174-1112; Appendix D)

The x4 multiplier board multiplies the frequency of an RF input signal by a factor of four. The board is made up of two identical x2 broadband frequency doublers.

The input signal (+5 dBm) at the fundamental frequency enters through SMA jack J1 and is fed through a 3 dB matching pad, consisting of R1, R2, and R3, to amplifier IC U1. The output of the amplifier stage is directed through a bandpass filter, consisting of L2 and C4, that is tuned to the fundamental frequency. The voltage measured at TP1

is typically +0.6 VDC. The first doubler stage consists of Z1 with bandpass filter L3 and C6 tuned to the second harmonic. The harmonic is amplified by U2 and fed through a bandpass filter, consisting of C10 and L5, also tuned to the second harmonic frequency. The voltage measured at TP2 is typically +1.2 VDC. The next doubler stage consists of Z2 with bandpass filter C12 and L6 tuned to the fourth harmonic of the fundamental frequency. The fourth harmonic is then amplified by U3 and fed to the SMA output jack of the board at J2. The typical LO signal output level is a nominal +15 dBm.

The +12 VDC for the board enters through jack J3-3 and is filtered by L7 and C16 before being distributed to the circuits on the board.

4.1.7.2 (A11-A2) VHF Filter/Mixer Board (1150-1102; Appendix D)

The VHF filter/mixer board is made up of three separate circuits: a filter and amplifier circuit for the LO input, a mixer stage, and a filter and amplifier for the RF output of the mixer. The board is mounted inside of (A11) the VHF mixer/amplifier enclosure assembly (1088067), an aluminum enclosure that provides RFI protection. The filter/amplifier board (1064252) is also mounted inside the enclosure.

The LO input (+5 dBm) connects to the board at J3 and is fed to a filter circuit. The input to the filter consists of C11, C12, and L5, with C12 adjusted for the best input loading. C13 and C17 are adjusted for the best frequency response and C18 is adjusted for the best output loading of the LO signal. Capacitor C15 is adjusted for the best coupling. The filtered LO is amplified by U2 and connected to LO output jack J4. Typically, the output at jack J4 is jumpered by a coaxial jumper to jack J5 on the board. The LO at J5 connects to mixer Z1 at pin 1 (+14 dBm).

The IF input connects to the board at J7 and is fed to mixer Z1 at pin 3 (-3 dBm).

Mixer Z1 takes the LO input at pin 1 and the IF input at pin 3 to produce an RF output at pin 8. The RF output at pin 8 (-14 dBm) connects through a pi-type attenuator, made up of R3, R4, and R5, before it is connected to RF output jack J6. Normally, jack J6 is connected by a coaxial jumper to J1 on the board. J1 connects to the input of a filter circuit, consisting of C25, C1, C23, C2, and L1, with C2 adjusted for the best input loading. C3 and C6 are adjusted for the best center frequency, C4 is adjusted for the best coupling, and C7 is adjusted for the best output loading of the RF signal. The filtered RF is amplified by U1 and connected to the RF output jack for the board at J2 (-2 dBm).

The +12 VDC needed for the operation of the board is supplied by an external power supply in the tray. The +12 VDC enters the board at J8, pin 3, and is filtered and isolated from the rest of the tray by L7 and C22 before being applied to the board.

4.1.7.3 (A11-A3) VHF High Band Filter/Amplifier Board (1064252; Appendix D)

The VHF high band filter/amplifier board is made up of two separate circuits: a filter circuit and an amplifier with a gain control circuit.

The RF input connects to the board at J7 and is fed through a channel filter circuit. The input to the filter consists of C27, C28, and C29, with C29 adjusted for the best input loading. C23 and C26 are adjusted for center frequency, with C24 adjusted for the best coupling, and C20 is adjusted for the best output loading of the RF signal. The filtered RF is connected to RF output jack J6; J6 is usually jumpered to jack J1 on the board.

The filtered RF at J1 connects through a 7-dB pi-type attenuator, consisting of R1,

R2, and R3, before it is wired to a pin-diode attenuator circuit. The pin-diode attenuator circuit is made up of CR1, CR2, and CR3 and is controlled by the bias current applied through R5. The diodes CR1, CR2, and CR3 are pin-type diodes with a broad intrinsic region sandwiched inside the diode. This broad intrinsic region causes the pin diodes to act as variable resistors instead of as detecting devices at the RF frequencies. The resistance values of the pin diodes are determined by the relative amount of forward bias that is applied to the diodes. Jumper W1 on J5 is set for manual gain or auto gain by its position on the jack. Between 1 and 2 is manual gain, which uses pot R9 to set the output level; between 2 and 3 is auto gain, which uses the external control voltage input to jack J4 as the level control. **NOTE:** This arrangement is not used in this configuration.

The level-controlled RF is pre-amplified by U1 and connected to Q1, the output amplifier for the board. C17 is used to maximize the RF signal. The RF output is amplified by Q1 and applied to the RF output jack for the board at J2.

The output from Q1 is first fed through direction coupler Z1 before exiting the board at J2, the RF output. The RF sample derived from Z1 has two functions. The first function is to provide an RF sample at J8 on the board that is fed to the front panel of the exciter tray through a voltage divider consisting of R19 and R18. The second function is to provide a peak-detected voltage that is used by the exciter tray for metering purposes. The sample provided by Z1, pin 3, is first fed through a dB pad consisting of R20, R21, and R22. The voltage is stepped up by a 1-to-4 transformer T1. The signal is then peak detected by C32 and C14 before being buffered and amplified by U2. The peak-detected voltage that is used for metering purposes is controlled by pot R28 on the board.

The +12 VDC needed for the operation of the board is supplied by an external power supply in the tray. The +12 VDC enters the board at J3, pin 3, and is filtered and isolated from the rest of the tray by L5 and C19 before being applied to the entire board. The -12 VDC enters the board at J3, pin 5, and is filtered and isolated from the rest of the tray by L6 and C35 before being applied to the entire board.

4.1.8 (A17) Transmitter Control Board (1265-1311; Appendix D)

The transmitter control board provides information on system control functions and the operational LED indications; these can be viewed on the front panel of the transmitter. The main control functions are for the Operate/Standby and Auto/Manual selections. When the transmitter is switched to Operate, the board supplies the enables to any external amplifier trays. The board also performs the automatic switching of the transmitter to Standby upon the loss of the video input when the transmitter is in Auto.

The transmitter control board contains a VSWR cutback circuit. If the VSWR of the transmitter increases above 20%, the VSWR cutback circuit will become active and cut back the output level of the transmitter, as needed, to maintain a maximum of 20% VSWR. An interlock (low) must be present at J8-24 for the transmitter to be switched to Operate and, when the interlock is present, the green Interlock LED DS5 will be lit.

4.1.8.1 Operate/Standby Switch S1

K1 is a magnetic latching relay that controls the switching of the transmitter from Operate and Standby. When the Operate/Standby switch S1, on the front panel of the tray, is moved to Operate, one coil of relay K1 energizes and causes the contacts to close and apply a low to U4B-9. If the transmitter interlock is present, and there is no overtemperature

fault, lows will also be applied to U4B-10, U4B-11, and U4B-12.

With all the low inputs to U4B, the output at U4B-13 will be low. The low biases off Q1 and this turns off the amber Standby LED DS1 on the front panel. In addition, this action applies a high to Q2 and turns on and lights the green Operate LED DS2 (also on the front panel). When Q2 is biased on, it connects a low to Q12 and biases it off; this allows the ALC to be applied to J1 and connect to any external amplifier trays. The low from U4B-13 is also applied to Q4 and Q24, which are biased off, and removes the disables from J1-4 and J18-1. The low from U4B-13 also connects to Q10, which is biased on, and connects a high to Q6, Q7, Q8, and Q9; these are biased on and apply -12 VDC enables to J8-2, J8-3, J8-4, and J8-5, which connect to any external amplifier trays. The high applied to Q2 is also connected to Q5 and Q26, which are biased on, and apply a low enable to J1-3, which connects to a remote operate indicator. The transmitter is now in the Operate mode.

When the Operate/Standby switch S1 is moved to Standby, the other coil of relay K1 energizes, causing the contacts to open and a high (+12 VDC) to be applied to U4B-9. The high at the input causes the output at U4B-13 to go high. The high biases on Q1 and applies a low to the amber Standby LED DS1, on the front panel, and turns on and applies a low to Q2. This causes Q2 to turn off and extinguishes the green Operate LED DS2. When Q12 is biased on, the output from U2C goes low and pulls the ALC voltages at J1 low; this lowers the gain of the external amplifier trays. The high from U4B-13 is applied to Q4 and Q24, which are biased on, and applies disables at J1-4 and J18-1. The high from U4B-13 connects to Q10, which is biased off. The Q10 bias off removes the high from Q6, Q7, Q8, and Q9, which are biased off, and removes the -12 VDC enables at J8-2, J8-3, J8-4, and J8-5, which connect to the external amplifier trays. The low

applied to Q2 is also connected to Q5 and Q26, which are biased off, and removes the remote enable at J1-3. The transmitter is now in the Standby mode.

4.1.8.2 Automatic/Manual Switch S2

K2 is a magnetic latching relay that switches the operation of the transmitter to Automatic or Manual using Auto/Manual switch S2 located on the front panel of the tray.

When S2 is set to the Auto position, the operation of the transmitter is controlled by the fault circuits and will stay in Operate even if Operate/Standby switch S1 is moved to Standby. With S2 in Auto, a low is applied to one coil in the relay and this energizes and closes the contacts. The closed contacts apply a low to the green Automatic LED DS3; as a result, DS3 is illuminated. The low from the relay connects to U5A, pin 2; U5D, pin 13; Q21; and Q23. When Q21 and Q23 are biased off, this causes their outputs to go high. The high from Q21 connects to the amber Manual LED DS4, on the front panel, biasing it off, and to Q22, biasing it on. The drain of Q22 goes low and is applied to J8-7; this enables any remote auto indicator connected to J8-7. The low to Q23 biases it off and removes the enable to any remote manual indicator connected to J8-6.

When S2 is set to the Manual position, the operation of the transmitter is no longer controlled by the fault circuits; it is controlled by Operate/Standby switch S1. With S2 in Manual, a low is applied to the other coil in the relay and this energizes and opens the contacts. The open contacts remove the low from the green Automatic LED DS3 on the front panel and causes it to extinguish. The high connects to U5A, pin 2; U5D, pin 13; Q21; and Q23. Q21 and Q23 are biased on; this causes their outputs to go low. The low from Q21 connects to the amber Manual LED DS4 on the front panel, biasing it on, and to Q22, biasing it off. The drain of Q22 goes high and is applied

to J8-7; this will disable any remote auto indicators connected to it J8-7. Q23 is biased on and applies a low enable to any remote manual indicator connected to J8-6.

4.1.8.3 Automatic Turning On and Off of the Transmitter Using the Presence of Video

The transmitter control board also allows the transmitter to be turned on and off by the presence of video at the transmitter when the transmitter is in Auto. When a video fault occurs due to the loss of video, J7-5 goes low. The low is applied through W1, on J10, to Q16, which is biased off, and to the red Video Loss Fault LED DS9, on the front panel, which will light. The drain of Q16 goes high and connects to U5B, pin 5, causing the output at pin 4 to go low. The low connects to Q18, which is biased off, and causes the drain of Q18 to go high. The high connects to U3D, pin 12, whose output at pin 14 goes high. The high connects to U5C, pins 8 and 9, causing its output at pin 10 to go low, and to U5A, pin 1, causing its output at pin 3 to go low.

With S2 set to Automatic, a low is applied to U5A, pin 2, and to U5D, pin 13. When U5A, pin 1, is high and U5A, pin 2, is low, it causes the output at pin 3 to go low. When U5D, pin 12, is low and U5D, pin 13, is low, it causes its output to go high. When U5A, pin 3, is low, it biases off Q20 and removes any pull down to the Operate switch. A high at U5D, pin 11, biases on Q19 and applies a low enable to the Standby switch that places the transmitter in the Standby mode.

When the video signal is returned, J7-5 goes high. The high is applied to Q16, which is biased on, and to the red Video Fault LED DS9, which is extinguished. The output of Q16 goes low and connects to U5B, pin 5. If there is no receiver ALC fault, U5B, pin 6, is also low; this causes the output at pin 4 to go high. The high connects to Q18, which is biased on, and

causes the drain of Q18 to go low. The low connects to U3D, pin 12, whose output at pin 14 goes low. The low connects to U5C, pins 8 and 9, which causes its output at pin 10 to go high, and to U5A, pin 1. With Auto/Manual switch S2 in Auto, a low is applied to U5A, pin 2, and to U5D, pin 13. When U5A, pins 1 and 2, is low, its output at pin 3 goes high. When pin 12 of U5D is high, the output of U5D at pin 11 goes low. When U5A, pin 3, is high, it biases on Q20 and applies a pull-down enable to the Operate switch. A low at U5D, pin 11, biases off Q19 and removes any pull down to the Standby switch. As a result of these actions, the transmitter is switched to Operate.

4.1.8.4 Faults

There are four possible faults, video loss fault, VSWR cutback fault, overtemperature fault, and ALC fault, which may occur in the transmitter and are applied to the transmitter control board. During normal operation, no faults are sent to the board. The receiver ALC fault circuit will only function if a receiver tray is part of the system. The overtemperature fault is controlled by the temperature of the external (A8) combiner assembly.

4.1.8.5 Video Loss Fault

If a video loss occurs while the transmitter is in Auto, the system will change to the Standby mode until the video is returned; at that point, it will immediately revert to Operate. A video loss fault applies a low from the ALC board to the video fault input at J7-5 on the board.

With jumper W1 in place on J10, the video fault is connected to LED DS9 and to Q16. The red Video Loss Fault LED DS9 on the front panel will light. Q16 is biased off and causes its drain to go high. The high is wired to U5B, pin 5, whose output at U5B, pin 4, goes low. The low is wired to Q18, which is biased off, and

causes the drain to go high. The high is connected to U3D, pin 12, which causes its output at U3D, pin 14, to go high. The high connects to U5A, pin 1, and, if the transmitter is in Auto, pin 2 of U5A is low. When pin 1 is high and pin 2 is low, the output of U5A goes low and reverse biases Q20, shutting it off. The high at U5C, pins 8 and 9, causes its output at pin 10 to go low. This low is connected to U5D, pin 12, and, if the transmitter is in Auto, pin 13 of U5D is also low. The lows on pins 12 and 13 cause the output to go high and forward bias Q19. The drain of Q19 goes low and connects the coil in relay K1, causing it to switch to Standby.

When the video returns, the video loss fault is removed from the video fault input at J7-5. With jumper W1 in place on J10, the base of Q16 goes high. The red Video Loss Fault LED DS9 on the front panel will be extinguished. Q16 is biased on, which causes its drain to go low. The low is wired to U5B, pin 5; U5B, pin 6, will be low if no ALC fault occurs. The two lows at the inputs make the output at U5B, pin 4, go high. The high is wired to Q18, which is biased on, causing the drain to go low. The low is connected to U3D, pin 12, which causes its output at U3D, pin 14, to go low. The low connects to U5A, pin 1, and, if the transmitter is in Auto, pin 2 of U5A is also low. With both inputs low, the output of U5A at pin 3 goes high. The high forward biases Q20 and causes its drain to go low. The low connects to the operate coil on relay K1 that switches the transmitter to Operate. The low at U5C, pins 8 and 9, causes its output at pin 10 to go high. This high is connected to U5D, pin 12, and, if the transmitter is in Auto, pin 13 of U5D is low. The high on pin 12 causes the output of U5D to go low and reverse bias Q19. The drain of Q19 goes high and this removes the low from the standby coil in relay K1.

4.1.8.6 Overtemperature Fault

In this 1 kW VHF transmitter the (A8-A1) thermal switch mounted on the (A8) Combiner Assembly connects to J11-1 & J11-35 on the rear of the VHF Exciter. These connect to J8-1 & J8-35 on the Transmitter Control Board. If the temperature of the thermal switch rises above 170° F, it closes and applies a low to J8-1. The low connects to Q3, which is biased off, and to the red Overtemperature LED DS6, which is biased on. The drain of Q3 goes high and connects to pins 11 and 12 of U4B. The high at the input to U4B causes it to go high and switches the Transmitter to Standby. This also removes the Operate Enable commands to the two external VHF amplifier trays.

4.1.8.7 VSWR Cutback Fault

The reflected power sample of the RF output of the transmitter is connected to J2, pin 9, of the transmitter control board. The sample connects to op-amp U1B, pin 5, which buffers the signal before it is split. One of the split-reflected samples connects to J1-5 on the board; J1-5 is wired to J10-5 on the rear of the tray for remote monitoring. Another split-reflected sample connects to position 3 on the front panel meter for the tray. The final split remote-reflected sample connects to U2B, pin 5.

If the reflected sample level increases above the level set by R22, the VSWR cutback pot, the output of U2B at pin 7, goes high. The high is connected to Q11 through CR11, which is biased on, making U2C, pin 10, low and causing U2C, pin 8, to go low. This low is split and fed out of the tray at J1-6, J1-7, J1-8, and J1-9. These are ALC outputs to the amplifier trays that cut back the output power of the amplifier trays. The low from U2C, pin 8, is also fed through coaxial jumper W2 on J13 and J14 to R73. R73 is a bias-adjust pot that sets the level of the pin attenuator bias available as an output at J16. The high at

U2B, pin 7, is also fed to the base of Q14 and Q13, which are forward biased. This produces a low at the drains that connect to the front panel amber VSWR Cutback LED DS7, causing it to light and indicate that the tray is in cutback, and to output jack J8-37 for the connection to a remote VSWR cutback indicator.

4.1.8.8 Receiver ALC Fault

If a receiver tray is part of the system, a sample of the ALC voltage from this tray is connected to J8-11 on the transmitter control board. If the receiver is operating normally, the ALC level that is applied to U3C, pin 9, remains below the trip level set by R35; as a result, the output at pin 13 stays high. The high is applied to the red ALC Fault LED DS8, which is off. The high also connects to U3A, pin 2, and to Q15. Q15 is biased on and the drain goes low. The low connects to U5B, pin 6. In addition, U5B normally has a low that is connected to U5B, pin 5, and produces a high at output pin 4. The high is wired to Q18, which is biased on, and makes its drain low. The low connects to U3D, pin 12, which, because the level is below the preset, the output at U3D, pin 14, goes low. A low at this point indicates a no-fault condition. The high that is connected to U3A, pin 2, causes its output to go low. The low is connected to Q25, which is biased off. The low is removed from J8-12, which will not light any remote receiver fault indicator that is connected to it.

If the receiver malfunctions, the ALC level applied to U3C, pin 9, goes high. This is above the level set by R35 and causes the output at pin 13 to go low. The low is applied to the red ALC Fault LED DS8, which lights. The low also connects to U3A, pin 2, and to Q15. Q15 is biased off and the drain goes high. The high connects to U5B, pin 6, and produces a low at output pin 4. The low is wired to Q18, which is biased off, and this makes its drain go high. The high connects to U3D, pin 12 and, because the level is above the preset, the output

at U3D, pin 14, goes high. A high at this point indicates a fault condition that switches the transmitter to Standby. The low connected to U3A, pin 2, causes its output to go high. The high is connected to Q25, which is biased on, and causes the drain to go low. The low is connected to J8-12, which can light any remote receiver fault indicator that is connected to it.

4.1.8.9 Metering

The front panel meter connects to J3-1 (-) and J3-2 (+), the output of switch S3, on the transmitter control board. The front panel meter has seven metering positions that are controlled by S3. They are Audio level, Video level, % Aural Power, % Visual Power, % Reflected Power, % Exciter Power, and ALC voltage. The video sample connects to the board at J5-4 and is connected through video calibration pot R20 to position 6 on front panel meter switch S3. The audio sample enters the board at J5-6 and is connected through audio calibration pot R19 to position 7 on front panel meter switch S3. The reflected sample connects to the board at J2-9 and is connected through buffer amplifier U1B and 100 Ω resistor R84 to position 3 on front panel meter switch S3. The visual sample connects to the board at J2-5 and is connected through buffer amplifier U1D and 100 Ω resistor R86 to position 4 on front panel meter switch S3. The aural sample connects to the board at J2-7 and is connected through buffer amplifier U1C and 100-watt resistor R85 to position 5 on front panel meter switch S3. The exciter sample connects to the board at J2-3 and is connected through buffer amplifier U1A and 100 Ω resistor R87 to position 2 on front panel meter switch S3. The ALC sample connects to the board at J6-1 and is connected through buffer amplifier U2C and ALC calibration pot R15 (which adjusts the output of U2A, pin 1) and through 100 Ω resistor R18 to position 1 on front panel meter switch S3. Typical readings on the meter are:

- Video = 1 Vpk-pk at white
- % Reflected = < 5%
- % Visual power = 100%
- % Aural power = 100%
- % Exciter = The level on the meter needed to attain 100% output power from the transmitter

Refer to the test specifications sheet for the transmitter for the actual reading:

- ALC = .8 VDC
- Audio = ± 25 kHz with a balanced audio input or ± 75 kHz with a composite audio input

Samples are provided for the remote metering of the exciter at J1-10, the visual at J8-26, the aural at J8-27, and the reflected at J1-5.

U6 is a temperature-sensor IC that gives the operator the ability to measure the temperature inside the tray by measuring the voltage at TP1. The sensor is set up for +10 mV equals 1 $^{\circ}$ F (for example, 750 mV equals 75 $^{\circ}$ F).

4.1.8.10 Operational Voltages

The +12 VDC needed for the operation of the transmitter control board enters the board at jack J4, pin 3. C28, L1, and L3 are for the filtering and isolation of the +12 VDC before it is split and applied to the rest of the board. The -12 VDC needed for the operation of the board enters the board at jack J4, pin 5. C29 and L2 are for the filtering and isolation of the -12 VDC before it is split and applied to the rest of the board.

The +12 VDC is split when it is connected to the board. Four of the +12 VDC outputs are fed out of the board at J8-16, J8-17, J8-18, and J8-19 through diodes CR7, CR8, CR9, or CR10 and resistors R50, R51, R52, or R53 are fed to any external amplifier trays for use in their logic circuits. The resistors are for current limiting and the diodes are to prevent

voltage feedback from the external amplifier trays.

4.1.9 (A19) Visual/Aural Metering Board (1265-1309; Appendix D)

The visual/aural metering board provides detected outputs of the visual, aural, and reflected output samples that are used for monitoring on the front panel meter. The board also provides adjustments for the calibration of the readings on the meter. These readings are attained from samples of the forward power and reflected power outputs of the tray.

A forward power sample, visual + aural, is applied to SMA jack J1 on the board. The input signal is split, with one path connected to forward power sample SMA jack J2 for monitoring purposes. The other path is connected through C1 to CR2, R4, R5, R6, C4, and CR1, which make up a detector circuit. The detected visual + aural signal is amplified by U6B and its output is split. One amplified output of U6B connects to the aural level circuit and the other output connects to the visual level circuit.

4.1.9.1 Aural Level Circuit

One of the detected visual + aural level outputs of U6B connects through C6 to the intercarrier filter circuit that consists of R13, R14, L1, C7, and C8; C8 and L1, the intercarrier filter, can be adjusted for a maximum aural reading. The filter notches out the video + aural and only leaves the 4.5 MHz difference frequency between the visual and aural, that is a good representation of the aural level. The 4.5 MHz signal is fed to buffer amplifier U6A. The output of U6A is detected by diode detector CR3 and U1A and then fed through aural calibration control R20 to amplifier U2D. The amplified output of U2D is split, with the main output connected through R21 to J6, pin 1, which supplies the aural level output to the front panel meter for monitoring. The other output of U2D is connected to aural null adjust R51 and

offset null adjust R48, which are adjusted to set up the visual power calibration.

4.1.9.2 Visual Level Circuit

The other detected visual + aural level output from U6B is connected to U1C and, if there is no scrambling, connects directly to intercarrier notch L3, which is adjusted to filter out the aural and the 4.5 MHz intercarrier frequencies, leaving only a visual-with-sync output. The visual-with-sync output is fed to a peak-detector circuit consisting of CR5 and U2A. The signal is then fed through visual calibration control R28, which is adjusted for a 100% visual reading with no aural, to amplifier U2B. The amplified visual peak of sync output is connected to comparator U2C. The other input to U2C is the level set by aural null adjust R51, which is adjusted for 100% visual power after the aural is added and the peak power is adjusted back to the reference level. Inputs to U2C also come from offset null adjust R48, which is adjusted for 0% visual power with the transmitter in Standby. The adjusted output is amplified by U3D and connected to the other input of U2C. The output of U2C connects to J6, pins 2 and 3, which supply the peak of sync visual level output to the front panel meter for monitoring.

If this board is operated with scrambling, using suppressed sync, the visual level circuit operates differently than described above because there is no peak of sync present on the forward sample input. For the board to operate properly, a timing pulse from the scrambling encoder must connect to the board at J4. This timing pulse is converted to sync pulses by U4A and U4B, which control the operation of Q2. Intercarrier notch L2 is tuned to remove any visual + aural signal that may remain.

The sync amplitude is controlled by gate amplitude adjust R25 and then applied to the minus input of U1C. At this point, it is inserted into the visual + aural signal

that is connected to the plus input of U1C, producing a peak of sync in the signal. The output of U1C is connected to intercarrier notch L3, which is adjusted to filter out the aural and the 4.5-MHz intercarrier frequencies. The visual-with-sync output is fed to a peak-detector circuit, consisting of CR5 and U2A, and then fed through visual calibration control R28 to amplifier U2B. The amplified visual peak of sync output is connected to J6, pins 2 and 3, which supply the peak of sync visual level output to the front panel meter for monitoring. R32 moves the pulse to where the sync should be and R25 sets the visual metering calibration with no sync present.

4.1.9.3 Reflected Level Circuit

A reflected-power sample is applied to J3 of the visual/aural metering board and is detected by diode detector CR7 and U3B. The detected output is fed through reflected calibration pot R39, which can be adjusted to control the gain of U3C. The output of U3C connects to J6, pin 7, which supplies a reflected-power level output to the front panel meter.

4.1.9.4 Voltages for Circuit Operation

The ± 12 VDC is applied to the board at J5. The +12 VDC is connected to J5, pin 3, and is isolated and filtered by L4 and C34 before it is connected to the rest of the board. The +12 VDC also connects to U5, a 5-VDC regulator that provides the voltage needed to operate U4. The -12 VDC is applied to J5, pin 1, and is isolated and filtered by L5 and C35 before it is connected to the rest of the board.

4.1.10 (A4-A14) Channel Oscillator Assembly, Dual Oven (1145-1202; Appendix D)

The channel oscillator assembly contains the channel oscillator board (1145-1201) that generates a stable frequency-reference signal of approximately 100

MHz. The channel oscillator assembly is an enclosure that provides temperature stability for the crystal oscillator. An SMA output at jack J1 and an RF sample at BNC connector jack J2 are also part of the assembly.

Adjustments can be made through access holes in the top cover of the assembly. These adjustments are set at the factory and should not be tampered with unless it is absolutely necessary and the proper, calibrated equipment is available. R1 is the temperature adjustment; C11 is the course-frequency adjustment; C9 is the fine-frequency adjustment; and C6, C18, L2, and L4 are adjusted for the maximum output of the frequency as measured at jack J1.

The +12 VDC for the assembly enters through FL1 and the circuit-ground connection is made at E1.

4.1.11 (Optional) (A4-A13) EEPROM FSK Identifier Board (1265-1308; Appendix D)

The (Optional) FSK identifier board, with EEPROM, generates a morse code identification call sign by sending a bias voltage to the IF attenuator board to amplitude modulate the aural carrier. This gives the station a means of automatically repeating its identification call sign, at a given time interval, to meet FCC requirements.

The starting circuit is made up of U1B and U1D, which are connected as a flip-flop, with gate U1A used as the set flip-flop. U1A automatically starts the flip-flop each time U3 completes its timing cycle. At the start of a cycle, U1B enables clock U2. U2 applies the clock pulses that set the speed, which is adjusted by R2, for when the identification code is sent to 12-bit binary counter U4. R2, fully clockwise (CW), is the fastest pulse train and R2, fully counter-clockwise (CCW), is the slowest pulse train. U4 provides binary outputs that address EEPROM U5.

The scans in U4 will continue until field effect transistor (FET) Q1 is gated on. The gate of Q1 is connected to pin 13 on U4, which is the maximum count used in the EEPROM, and will provide a reset pulse each time the binary counter goes high on pin 13. The reset pulse, when the drain of Q1 goes low, is applied to the flip-flop and the timer U3, which determines the length of time between the sending of the identification code. R14 is adjusted to set this time interval. R14, fully CW, is the longest interval between identification calls, approximately eight minutes. R14, fully CCW, is the shortest interval between the sending of the code (approximately 10 seconds).

U6B is an amplifier connected to the output of U5, which turns the LED DS1 on and off at the rate set by R2. This gives the operator a visual indication that the FSK identifier board is operating and at the rate at which it is operating.

The data output of U5, which is serial, is connected to U6A, whose output shifts low and high, and is applied to the VCXO board, which shifts the frequency according to the programming of U5. The deviation of the shift is adjusted by R4 and is typically set at 1 kHz. Once R4 is set, R9 is re-adjusted to -1.5 VDC at J3-2.

The +12 VDC from an external power supply enters the board at J1, pin 3. The voltage is fed through RF choke L1 and is filtered by C1 before being applied to the rest of the tray. The +12 VDC is also applied to U7, which is a voltage regulator that regulates its output at +5 VDC. The +5 VDC is fed to the ICs on the board. The -12 VDC from an external power supply enters the board at J1, pin 5. The voltage is fed through RF choke L2 and filtered by C2 before being applied to the rest of the tray.

4.1.12 (Optional) (A4-A12) IF Attenuator Board (1150-1201; Appendix D)

The (Optional) IF attenuator board is operated with the FSK identifier board to produce an amplitude-modulated aural IF signal for broadcasting the required FCC station identification call sign at the proper time intervals.

The board contains a pin-diode attenuation circuit that consists of CR1 and the two resistors R2 and R3. The bias output of the FSK identifier board is applied to J3 of the IF attenuator board. As the bias applied to J3 increases and decreases, the amplitude of the aural IF signal, which enters the board at J1 and exits the board at J2, will increase and decrease. This produces an amplitude-modulated aural IF signal at J2, the aural IF output jack of the board.

4.2 (A6 and A7) VHF High Band Amplifier Trays (1301169; Appendix C)

The On Channel RF signal (+3 dBm pk-sync + aural), enters the rear of the Tray at the "BNC" Jack J1 and is fed through J1 of the (A1) Enclosure Assembly to J1 of (A1-A1) the Phase Shifter Board (1198-1603).

4.2.1 (A1-A1) Phase Shifter Board (1198-1603; Appendix D)

The Board provides a Phase Shift adjustment of the RF Signal that is needed to provide maximum output during the combining the two VHF Amplifier Trays in the transmitter. A front panel mounted Phase Shift Potentiometer (R2), which connects to J3 of the Board, controls the Phase of the RF Signal.

If the Input Signal level to the Phase Shifter Board falls below a preset level, a High, which is an Input Fault, connects from J5 of the board to J14 on the AGC Control Board. When an Input Fault

occurs, the AGC Control Board generates a Fault Output at J1 that is connected to J4 on the Filter/Amplifier Board. The Fault cuts back the RF Signal level using the Pin Diode Attenuator Circuit located on the Filter/Amplifier Board.

The output at J2 of the Phase Shifter Board is directed to J1 the input jack on (A2) an enclosure that contains the filter/amplifier board and the high band driver pallet.

4.2.2 (A2-A1) Filter/Amplifier Board (1301178; Appendix D)

The phase controlled output of the Phase Shifter Board (+7 dBm pk-sync + aural) is directed to the (J7), the Input Jack of (A2-A1) a Filter/Amplifier Board (1301178) which is made up of two circuits.

The first circuit is a Channel Filter that is adjusted for the desired Channel Frequency and bandwidth. The filtered output is connected to the second circuit that contains two amplifiers. The RF connects through a Pin Diode Attenuator Circuit to an amplifier IC U1. The amplitude of the RF Signal through the Pin Diode Attenuator Circuit is controlled by the voltage applied to J4 the External Control Jack of the Board. The Jumper W1 on J5 should be between Pins 2 & 3 which provides for external control thru J4 of the Gain of the Board and therefore the Output level of the Tray. The front panel mounted Gain Pot (R3) connects to the AGC Control Board and adjusts the AGC Pin Attenuator Bias Voltage that connects to J4 on the Filter/Amplifier Board.

The RF signal, after the Pin Attenuator Circuit, is amplified by the second amplifier stage (Q1) to about +12 dBm pk-sync + aural that is connected to the output of the board at J2.

4.2.3 (A2-A2) High Band Driver Pallet (P-10-VHF-H; Appendix D)

The RF output of the Filter/Amplifier Board connects to J1 on (A2-A2) the High Band VHF Driver Pallet (P10-VHF-H) made by Delta RF Technology. The board contains a RF Power FET that has a gain of approximately 20 dB.

The RF output of the Board at J2 (+31 dBm pk-sync + aural) connects to J2 of (A3) a RF enclosure, which contains the Overdrive Protection Board, the High Band Amplifier Board and the 3 Way Splitter Board.

4.2.4 (A3-A1) Overdrive Protection Board (1198-1601; Appendix D)

The signal is connected to J4 of (A3-A1) the Overdrive Protection Board (1198-1601).

The RF Signal is thru connected directly to J5 the RF Output Jack of the Board. A sample of the RF on the board is applied to a diode detector circuit consisting of CR1 and U1A. The gain of amplifier U1D is controlled by the Detector Gain Pot R11 which is set to +.4 VDC as measured at TP1. The set output level of U1D is connected to the comparator IC U1B. The Trip Point for the comparator is adjusted by R12, typically to 110% Output Power. When the signal reaches that level, the Overdrive Protection Board will cut back the output power of the Tray and the Red Overdrive LED (DS1) located on the Board and the Red Overdrive LED (DS1) mounted on the front panel will light. Typically the output power level, will bounce Down, then Up in level and continue bouncing until the Output Level is lowered to normal operating level, 100 %. The Red Overdrive LED (DS1), the Green Module LED (DS3) and the Enable LED (DS2) may blink On and Off during the bouncing of the output level and is a Normal occurrence. The greater the output level is above 110 %, the larger the bounce.

4.2.5 (A3-A2) High Band VHF Amplifier Pallet (P200-VHF-H; Appendix D)

The RF Output of the Overdrive Protection Board at J5 connects to J1 on (A3-A2) the High Band VHF Amplifier Pallet (P200-VHF-H) made by Delta RF Technology. The pallet amplifies the RF to approximately +45 dBm pk-sync + aural.

The output of the high band VHF amplifier pallet at J2 connects to J1 on (A3-A3) the 3 Way Splitter Board (1301161).

4.2.6 (A3-A3) 3 Way Splitter Board (1301161; Appendix D)

The Splitter Board takes the +45 dBm and provides three +40 dBm outputs that connect to J1, J2 and J3 of (A4) the final Amplifier Enclosure.

4.2.7 (A4-A1 thru A3) VHF Output Amplifier Pallets (P400-VHF-H; Appendix D)

The three RF outputs connect to (A4) the Final Amplifier Enclosure, which contains three (A4-A1, A4-A2 & A4-A3) High Band Output Amplifier Pallets (P400-VHF-H) made by Delta RF Technology. The RF Signals connect to J1 on each of the High Band Output Amplifier Pallets. Each amplifier pallet provides approximately 13 dB gain.

The RF signal inputs to the Output Amplifier Boards (+40 dBm) are amplified to +53.3 dBm pk-sync + aural outputs at J2 of each board. The outputs are connected to J1, J2 and J3 on (A5-A1) a 3 Way Combiner Board (1301157).

4.2.8 (A5-A1) 3 Way Combiner Board (1301157; Appendix D)

The 3 Way Combiner takes the three +53.3 dBm pk-sync + aural inputs and combines them to form the approximate 750-Watt RF Output at J5 of the

Combiner which connects to J2, the RF Output Jack of the Tray.

The 3 Way Combiner Board provides a Forward Power Sample at J6 and a Reflected Output Power Sample at J7. The Forward Output Power Sample connects to J4 on (A13) the AGC Control Board. The Reflected Output Power Sample connects to J5 on (A13) the AGC Control Board.

4.2.9 (A13) AGC Control Board (1142-1601; Appendix D)

The AGC Control Board contains two peak detector networks which provide detected outputs that are used for Front Panel and Remote Meter Indications of Forward and Reflected Output Power Levels, AGC Detector Voltage Level and also the VSWR Cutback protection if the Reflected Power level increases above the preset level.

The AGC Control Board provides AGC, VSWR Cutback and Module Fault operations for the VHF amplifier tray in which it is mounted.

4.2.9.1 LED Status Indicators

A -12 VDC Enable from the Exciter tray is applied to J10 Pin 10. This Negative Enable causes the J-FET Q9 to be Biased OFF and a High to be applied to Q4 that is Biased On that lights the front panel Enable Indicator. The High is also applied to J10 Pin 6 that is a High Enable to the Switching Power Supply, only if there is no Overtemperature Fault, which is a Low applied to J10 Pin 5. The High also connects to the Base of Q8 that forward Biases it and connects a Low to Q7 which Biases it Off. If the Output Power Level of the Tray is above the preset level and Q7 is biased Off, Q6 and Q5 will be Biased On and the Module Status Indicator LED will be illuminated.

If the Enable is removed from J10 Pin 10, Q9 will turn On applying a Low to Q4 and to Q8. The Low to Q4 turns it Off which

extinguishes the Enable Indicator at J10-8. The Low to Q8 turns it Off which turns On Q7 causing a Low to be applied to Q5 and Q6 that are Biased Off which turns Off the Module Status Indicator.

A voltage sample from the Switching Power Supply is applied to Jack J9 Pin 1 of the Board and is connected through R86 to the front panel Meter for monitoring. R86 is adjustable to calibrate the voltage reading on the front panel meter.

4.2.9.2 Front Panel Metering

A Forward Power Sample of the output of the Tray is applied to Jack J4 of the Board. CR11 along with C16 and L3 detect the Peak Level that is then buffered by U3C, amplified by U3D and applied to the Front Panel Meter. R44 is adjustable to calibrate the % Forward Power indication on the Front Panel Meter. A Forward Power Sample also is sent to the Remote Interface Panel. The Input Forward Power Sample at J4 is split and fed to the divider R40 and R39 and then to the Front Panel through Jack J3 for monitoring.

A Sample of the Reflected Power output of the Tray is applied to Jack J5 and is detected in the same manner as the Forward Power. R53 calibrates the Front Panel Meter in the % Reflected Power position.

4.2.9.3 Automatic Gain Control

The board contains the Automatic Gain Control (AGC) function for the Tray in which it is mounted. An AGC Reference level input from the Upconverter Tray is applied to J6 Pin 2 and is amplified by U3B. The Output of U3B is split with one path directed to the Front Panel Gain potentiometer that sets the Output Power Level of the Tray. The Voltage at the arm of the Front Panel Gain Pot is amplified by U2C and compared to the Output Power of the Tray by U2D. The Error Voltage from U2D is sent through

J1, when S1 is in the Auto position, to the Variable Gain/Phase Board on which it connects to the Pin Diode Attenuator circuit. This AGC Voltage Level is metered on the front panel through J13. The Tray can also be operated in Manual Gain by switching S1 to the Manual Position and adjusting R5 for the desired Output Power Level.

The other path at the output of U3B, directs the Input AGC Voltage to the amplifier U6D whose output is fed to the (+) Input of the comparator U6C. A Sample of the Forward Power Level of the Tray at U3D is amplified by U6A and fed to the (-) Input of the comparator U6C. The two levels are compared by U6C and the result is fed to U6B whose output is controlled by the reference level set by R75 and R76. If the Difference between the Output Power Level and the Input Level drops significantly, U6B Pin 7 goes Low, Q5 and Q6 Turn Off causing the Module Status LED to go out and the Remote Module Status to be removed.

4.2.9.4 Operational Voltages

U7 is a 3 Terminal Regulator IC that takes the +28 VDC input from the Switching Power Supply and produces the +12 VDC needed for the operation of the Board. U8 is a +5 VDC Regulator that takes the +12 VDC input from the Exciter Tray or from the Board and produces the +5 VDC needed to power the front panel Indicators. Using the +12 VDC from the Exciter Tray permits the operation of the Front Panel Indicators even if the Switching Power Supply is not Turned On.

4.2.10 (A10) +28 VDC Switching Power Supply Assembly

(A10) The +28 VDC Switching Power Supply uses the AC input through the 15A circuit breaker CB1 and provides the +28 VDC needed for operation of the tray.

The +28 VDC output of the switching power supply assembly connects to (A8) the Current Metering Board.

4.2.11 (A8) Current Metering Board (1301316; Appendix D)

The Current Metering Board distributes the voltages through fuses to the Amplifier Devices on the Filter/Amplifier, High Band Driver Board, the High Band Amplifier Board and the three Final High Band Amplifier Boards. The Fuses F1, F2 & F3 are 15 Amp, F4 is 5 Amp, F6 is 2 Amp and F7 is 1 Amp Fuse. F5 is not used in this configuration. There are two Spare Fuses, one 1 Amp and one 15 Amp, located on the top, right rear of the Tray.

Fuse F1 protects (A4-A1) the High Band Output Amplifier Pallet, Fuse F2 protects (A4-A2) the High Band Output Amplifier Pallet, Fuse F3 protects (A4-A3) the High Band Output Amplifier Pallet, Fuse F4 protects (A3-A2) the High Band Amplifier Pallet, and Fuse F6 protects (A2-A1) the Filter/Amplifier Board. Fuse F7 supplies +28 VDC to J8 Pin 2 on the AGC Control Board. The +28 VDC is connected to the Regulator IC U7 that takes the +28 VDC and provides a +12 VDC output.

The +12 VDC is used for operation of the AGC Control Board and also the +12 VDC is connected through the Current Metering Board, jumper from TB1-5 to TB1-6, to the Phase Shifter Board, the Filter/Amplifier Board and the Overdrive Protection Board. The Current Metering Board also supplies sample outputs of the operating currents of the amplifier devices in the Tray to the front panel Current Meter.

The Meter in the (I_1) position reads the current for the (A4-A1) P400 High Band Output Amplifier Board, (I_2) for the (A4-A2) P400 High Band Output Amplifier Board and (I_3) for the (A4-A3) P400 High Band Output Amplifier Board. The (I_D) position reads the current for the (A3-A2) P200 High Band Amplifier Board. To read

the desired current, Switch S2 to the proper position checking that S1 is in the Current position. These current readings can be used when setting up the Idling Currents, no RF Drive applied, for the devices. (I_1 , I_2 & I_3) are set for 6 Amps max. I_D is set for 3 Amps max. (NOTE: All front panel current readings must be multiplied by 2 for the proper readings.)

4.2.12 Operation of the VHF Amplifier Tray

The 220 VAC from the AC distribution panel is applied through Jack J4 to Terminal Block TB1 in the Tray. When (CB1) the 15 Amp rear panel mounted AC Circuit Breaker is switched On, the 220 VAC is distributed from TB1 to (A11 & A12) two cooling Fans, which will operate, and to (A10) the Switching Power Supply. There are two Surge Suppressors, VR1 and VR2, mounted on TB1 that provide protection from transients or surges on the input AC Line. There are two Surge Suppressors, VR3 and VR4, mounted at the input to the switching power supply from each AC Line to ground, which also provide protection from transients or surges on the AC Line.

The switching power Supply only operates when the Power Supply Enable Control Line, Jack (J3 Pins 9 & 10), located on the rear of the Tray, are shorted. The Enable is generated by the VHF exciter tray when the transmitter is switched to Operate. The Enable is applied to (A13) the AGC Control Board (1142-1601), which, if there is no Thermal Fault, connects the Enable from J10 Pins 6 & 7 to J2-6 & 4 on the Switching Power Supply Assembly. The Green Enable Front Panel LED (DS2) will light, indicating an Enable is present. If the Amplifier Array is in Standby or if a Thermal Fault occurs, the AGC Control Board will not Enable the Switching Power Supply, therefore the +28 VDC will be removed from the Amplifier Modules and the Front Panel Enable LED and Module Status LEDs will be out.

The front panel Meter (A9), using (S1) the Front Panel Selector Switch, monitors the AGC Voltage, % Output Reflected Power, % Forward Power and the Switching Power Supply Voltage (+28 VDC). The Meter in the AGC position will read anywhere from 1 Volts to 2 Volts. The Meter is calibrated in the Power Supply position using R86 located on the AGC Control Board. The % Output Power is calibrated using R44 and the % Reflected Power is calibrated using R53, located on the AGC Control Board. With S1 in the Current Position, S2 is switched to read the Idling Currents, no RF Drive applied, of the High Band Output Amplifier Boards.

Typical operating readings are an RF Current of 12 Amps for the three final P400 Amplifier Pallets I₁, I₂ & I₃ positions and 6 Amps for the P200 High Band Amplifier pallet in the I_D position. These readings are with 100 % output power for the transmitter with a black picture.

The Reflected Power Sample, from the 3 Way Combiner Board, is fed back to the AGC Control Board at J5. On the board the Reflected Sample is connected thru the detector circuit to a VSWR Cutback circuit (U13C). If the Reflected power increases above 20 %, the output power of the Tray, as set by R60 (VSWR

Cutback) on the AGC Control Board, will be cutback to maintain a 20 % Reflected Output level. The Red LED (DS4) VSWR Cutback, located on the front panel, will remain lit until the Reflected level drops below 20 %.

There are three Thermal Switches in the amplifier Tray for overtemperature protection. Two of the Thermal Switches (A4-A5 & A4-A6) are mounted on the rear of (A4) the heatsink for the High Band Amplifier Pallets and the third Thermal Switch (A5-A2) is mounted on the heatsink for (A5-A1) the 3 Way Combiner Board. The Thermal Switches close when the heatsink on which it is mounted reaches a temperature of 175° F. The closed Thermal Switch causes the AGC Control Board, to remove the Enable to the Switching Power Supply, eliminating the +28 VDC, and also to light the Red LED Indicator, Overtemperature (DS5), mounted on the front panel. The AGC Control Board extinguishes the Module Status LED (DS3).

This completes the circuit descriptions for the VHF amplifier tray, and also for the other trays, assemblies, subassemblies and boards that make up the 435B Transmitter.

Chapter 5

Detailed Alignment Procedures

The 435B transmitter was aligned at the factory and should not require additional alignments to achieve normal operation.

This transmitter operates using the baseband audio and video inputs or, if the (optional) 4.5-MHz composite input kit is purchased, either a single composite video + 4.5-MHz input or separate baseband video and audio inputs.

Check that the RF output at J2 of (A9) the bandpass filter assembly is terminated into a dummy load of at least 1000 watts. While performing the alignment, refer to the Test Data Sheet for the transmitter and compare the final readings from the factory with the readings on each of the trays. They should be very similar. If a reading is off by a significant amount, the problem is likely to be in that tray.

Switch on the main AC and the VHF exciter circuit breakers on the AC distribution panel behind the rear cabinet door.

5.1 (A4) VHF High Band Exciter Tray (1070901; Appendix C)

5.1.1 VHF High Band Exciter Tray with Baseband Video and Audio Inputs

The (A4) VHF high band exciter tray (1070901) has adjustments for video levels, audio modulation levels, and other related parameters.

Connect an NTSC baseband video test signal input (1 Vpk-pk) to the transmitter video input jack J2 on the (A12) remote interface panel. Jacks J1 and J2 on the VHF exciter tray are loop-through connected and the unused jack can be used as a video source for another transmitter by removing jumper W4 on

jack J3 on (A5) the sync tip clamp modulator board (1265-1302). Connect a baseband audio input (+10 dBm) to the balanced audio input terminal block TB1-1 (+), TB1-2 (-), and TB1-3 (ground). If stereo/composite audio is provided, connect it to BNC jack J6, the composite audio input jack on the remote interface panel. Jacks J3 and J13 on the rear of the exciter panel are loop-through connected and the unused jack can be used as an audio source for another transmitter by removing jumper W1 on jack J15 on the aural IF synthesizer.

Look at the front panel meter on the VHF exciter tray. In the Video position, the meter indicates active video from 0 to 1 Vpk-pk. The normal video input level is 1 Vpk-pk on the meter. If this reading is not at the proper level, the overall video level can be changed by adjusting video level control R12 on the sync tip clamp/modulator board.

Switch the meter to the Audio position to show the audio deviation (modulation level) of the signal from 0 to 100 kHz. The aural IF synthesizer board was factory set for a ± 25 kHz deviation with a balanced audio input of +10 dBm. If the reading is at not the correct level, adjust balanced audio gain pot R13 on the aural IF synthesizer board, as needed, to attain the ± 25 kHz deviation. The aural IF synthesizer board was factory set for a ± 75 kHz deviation with a composite audio input of 1 Vpk-pk. If this reading is not correct, adjust composite audio gain pot R17 on the aural IF synthesizer board, as needed, for the ± 75 kHz deviation.

5.1.2 VHF H.B. Exciter Tray with the (Optional) 4.5-MHz Composite Input Kit

With the 4.5-MHz composite input kit, the (A4) VHF exciter tray (1070901) is

able to operate using either the separate video and audio baseband inputs or the single 4.5-MHz composite input. The 4.5-MHz composite input kit includes a composite 4.5-MHz filter board (1227-1244) and a 4.5-MHz bandpass filter board (1265-1307).

To align the VHF exciter using baseband video and audio, refer to the alignment instructions for baseband inputs described in this chapter. Select the baseband input operation by applying a baseband select, using a jumper or closed contacts, connected between J7-6 and J7-7 on the rear of the tray.

To operate the transmitter using the 4.5-MHz composite input, remove the baseband select command from J7-6 and J7-7 on the rear of the tray.

Connect a multiburst test signal from an envelope delay measurement set to the video input jack J2 on the A/V input & remote interface panel. On (A24) the composite 4.5-MHz filter board (1227-1244), connect an oscilloscope between J7, the center pin, and pin 1 or 3, which are ground. Adjust C21, if necessary, for the best frequency response. Adjust R32 for a signal level of 1 Vpk-pk on the oscilloscope. The output, as measured at J6 and J7 of the board, should be video only with a minimum 4.5-MHz aural subcarrier.

On the (A25) 4.5-MHz bandpass filter board (1265-1307), adjust the filter with L2, C3, L4, and C7 for a frequency response of no greater than ± 0.3 dB from 4.4 to 4.6 MHz. Adjust C19 for an overall peak-to-peak variation of less than ± 0.3 dB from 4.4 MHz to 4.6 MHz. Recheck the frequency response; it may have changed with the adjustment of the envelope delay.

5.1.3 VHF H.B. Exciter Tray with either Baseband or the 4.5-MHz Composite Input

The IF section of the VHF H.B. exciter tray includes adjustments for automatic level control (ALC), linearity (amplitude predistortion), and phase (phase change vs. level) predistortion for correction of the nonlinearities of the RF amplifier trays. The upconverter section also includes adjustments to the local oscillator chain tuning and the local oscillator center frequency tuning. Both of these were completed at the factory and should not require adjustments at this time.

Move the Operate/Standby switch on the VHF exciter tray to Operate. The setup of the RF output includes an adjustment to the drive level of the two VHF amplifier trays, the adjustment of the linearity and phase predistortion (which compensate for any nonlinear responses of the amplifier trays), and the gain and phasing adjustments of the two VHF amplifier trays.

Verify that all of the red LEDs on the ALC board are extinguished. The following list describes the meaning of each LED when they are illuminated:

- DS1 (Input Fault) – Indicates that an abnormally low or no IF is present at the input of the board
- DS2 (ALC Fault) – Indicates that the ALC circuit is unable to maintain the signal level requested by the ALC reference. This is normally due to excessive attenuation in the linearity signal path or the IF phase corrector signal path or because jumper W3 on J6 is in the Manual ALC Gain position.
- DS3 (Video Loss) – Indicates a loss of video at the input of the board
- DS4 (Mute) – Indicates that a visual Mute command is present (not used in this configuration)
- DS5 (Modulator Enable) – Indicates that the modulator IF output has been selected (this is only used if a

receiver tray is present in the system). DS5 is always on with no receiver.

The ALC is muted when the transmitter is in Standby. To monitor the ALC, turn off the two amplifier on/off circuit breakers on the AC distribution assembly at the rear of the cabinet and switch the transmitter to Operate. Adjust the power adjust gain pot on the front panel of the VHF exciter tray to obtain +0.8 VDC on the front panel meter in the ALC position. On the ALC board (1265-1305), move jumper W3 on J6 to the Manual position, between pins 2 and 3, and adjust R87 on the ALC board for +0.8 VDC on the front panel meter in the ALC position. Move jumper W3 back to Auto (between pins 1 and 2); this is the normal operating position. The detected IF signal level at J19-2 of the ALC board is connected to the transmitter control board that distributes the level to the two VHF amplifier trays where it is used as a reference for the automatic gain control (AGC) in each amplifier tray.

5.1.4 VHF H.B. Exciter Tray Board level Adjustments

5.1.4.1 (Optional) 4.5-MHz Composite Input Kit

If the (optional) 4.5-MHz composite input kit is purchased, the tray is capable of operating by using either the 4.5-MHz composite input or the baseband audio and video inputs. The kit adds the (A24) composite 4.5-MHz filter board (1227-1244; Appendix D) and the (A25) 4.5-MHz bandpass filter board (1265-1307; Appendix D) to the transmitter. When the 4.5 MHz intercarrier signal generated by the 4.5 MHz composite input has been selected by the 4.5 MHz composite input kit, the 4.5-MHz generated by the aural IF synthesizer board is not used. When the 4.5 MHz intercarrier signal generated by the baseband video and audio inputs with baseband has been selected by the 4.5 MHz composite input kit, the composite 4.5 MHz filter board and the

4.5 MHz bandpass filter board are not used.

The tray has been factory tuned and should not need any alignments to achieve normal operation. To align the tray for the 4.5 MHz composite input, apply the 4.5 MHz composite input, with the test signals used as needed, to the video input jack (J1 or J2 [loop-through connections]) on the rear of the tray. Select the 4.5 MHz composite input by removing the baseband select from J7-6 and J7-7 on the rear of the tray.

To align the exciter using baseband video and audio inputs, apply the baseband video, with the test signals used as needed, to the video input jack (J2) and the baseband audio to the proper baseband audio input on the A/V input & remote interface panel. For balanced audio input, connect TB1-1(+), TB1-2(grnd), and TB1-3 (-). For composite/stereo audio, connect the composite audio input jack (J6). Connect a baseband select from J7-6 and J7-7 on the rear of the exciter tray.

5.1.4.1.1 (Optional) (A24) Composite 4.5-MHz Filter Board (1227-1244; Appendix D)

This board is part of the 4.5-MHz input kit and will only function properly with a 4.5-MHz composite input signal and the 4.5-MHz composite input selected. To align this board:

1. Connect the test signal from an envelope delay measurement set to the video input of the tray at J1 or J2.
2. Connect an oscilloscope to jack J7, video out, between the J7 center pin and pin 1 or 3 (ground). Adjust C21, frequency response, if needed, for the best frequency response. Adjust R32, video gain, for a signal level of 1 Vpk-pk on the oscilloscope.

The output at J6 and J7 on the board should be video only, without the 4.5-MHz aural subcarrier.

5.1.4.1.2 (Optional) (A25) 4.5 MHz Bandpass Filter Board (1265-1307; Appendix D)

This board is part of the 4.5-MHz input kit and will only function properly with a 4.5 MHz composite input signal and the 4.5 MHz composite input selected. To align this board:

1. Adjust the filter with L2, C3, L4, and C7 for a frequency response of no greater than ± 0.3 dB from 4.4 to 4.6 MHz.
2. Adjust C19 for an overall peak-to-peak variation of less than ± 0.3 dB from 4.4 MHz to 4.6 MHz.
2. Recheck the frequency response; it may have changed with the adjustment of the envelope delay. If necessary, retune the board.

5.1.4.2 (A6) Delay Equalizer Board (1227-1204; Appendix D)

The jumper W1 on J5 of the sync tip clamp/modulator board, if present, must be in the Enable position between pins 2 and 3.

NOTE: This board has been factory tuned and should not be retuned without the proper equipment.

To tune this board:

1. Connect a sinX/X test signal into jack J1-2 on the delay equalizer board.
2. Monitor the video output of the board, at the video sample jack J2, with a video measuring set, such as the VM700, adjusted to measure group delay.

3. Tune the four stages of the board using the variable inductors (L1-L4) and potentiometers (R7, R12, R17, and R22) until the signal attains the FCC group delay curve. The stages are arranged in order of increasing frequency. Adjust R29, as needed, to attain the same level out of the board as into the board.

5.1.4.3 (A7) IF Carrier Oven Oscillator Board (1191-1404; Appendix D)

To align this board:

1. While monitoring J3 with a spectrum analyzer, observe the 45.75-MHz visual IF (typical +5 dBm).
2. Connect a frequency counter to J3 and adjust C17 for 45.750000 MHz.
3. Connect a frequency counter to J1 and check for 50 kHz, which is the aural phase lock loop reference.

5.1.4.4 (A5) Sync Tip Clamp/Modulator Board (1265-1302; Appendix D)

To align this board:

1. Determine if jumper W4 on jack J3 is present. Jumper W4 terminates the video input into 75 Ω . Remove jumper W4 if a video loop-through is required on the rear chassis at jacks J1 and J2.
2. Set the controls R20, the white clip, R24, the sync clip, and R45, the sync stretch cut-in, to their full CCW position. Set R48, the sync magnitude, fully CW and place the jumper W7 on jack J4 to the Clamp-Off, Disable, position.
3. Connect a 5-step staircase video test signal to the input of the transmitter.

4. Monitor TP2 with an oscilloscope. Adjust R12, the video gain pot, for 1 Vpk-pk.
5. Change the video input test signal to a multiburst test pattern. While monitoring TP2, adjust C8 and R32 for a flat-frequency response. Change the input video test signal back to the 5-step staircase.
6. Monitor TP2 with an oscilloscope. Adjust pot R41, manual offset, for a blanking level of -0.8 VDC. The waveform shown in Figure 5-1 should be observed. Move the jumper W2 on J4 to the Clamp Enable position. Adjust pot R152, depth of modulation, for a blanking level of -0.8 VDC.

NOTE: This waveform represents the theoretical level for proper modulation depth. Step 9 below describes how to set the modulation depth through the use of a television demodulator or a zero-spanned spectrum analyzer tuned to the visual IF frequency.

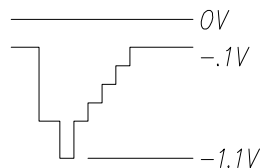

Figure 5-1. Waveform

7. The following test setup is for the adjustment of the depth of modulation and ICPM at IF:
 - A. Remove the cable that is on J18 and connect the double-sideband, 45.75-MHz visual IF signal from J18 to a 10-dB splitter/coupler. Connect the coupled port of the splitter/coupler to the RF input of a television demodulator. Connect the direct port to a spectrum analyzer.
 - B. Connect the 75 Ω video output of the demodulator to the video input of a waveform monitor. For ICPM measurements, also connect the quadrature output of the demodulator to the horizontal input of the waveform monitor using a 250-kHz, low-pass filter. (An oscilloscope can be used in place of a waveform monitor).
 - C. Set the controls of the demodulator to the following:
 - Detector mode – Cont
 - Sound trap – In
 - Zero carrier – On
 - Auto – Sync
 - Audio source – Split
 - De-emphasis – In
8. Move jumper W7 on J4 to the Clamp Disable position. Readjust pot R41, manual offset, for the correct depth of modulation by observing the demodulated waveform on the waveform monitor or on the spectrum analyzer set to zero span.
9. Check the demodulated video for a proper sync-to-video ratio (sync is 28.6% of the total white video signal). If sync stretch is needed, adjust R45, sync stretch cut-in, until sync stretch occurs. Adjust R48, sync stretch magnitude, for the proper amount of stretch. Readjust R41, manual offset, if needed, for the correct depth of modulation.
10. Move jumper W7 on J4 to the Clamp Enable position. Readjust pot R152, depth of modulation, for the correct depth of modulation.
11. Set the waveform monitor to display ICPM. Preset R53 fully CCW, adjust C78 for the greatest effect at

- white on the ICPM display, and then adjust R53 for minimum ICPM.
12. Recheck the depth of modulation and, if necessary, adjust R152, depth of modulation.
 13. On a spectrum analyzer, adjust pot R70 for a level of approximately -10 dBm at J18.
 14. Remove the input video test signal. Place the front panel meter in the video position and, while monitoring the meter, adjust pot R144, zero adjust, for a reading of zero.
 15. Replace the input video test signal (the 5-step staircase). Turn the front panel meter to the video position and adjust R20 on the transmitter control board for a reading of 1 volt (10 on the 0 to 10 scale). This board does not have sync metering.
 16. Reconnect the plug to J18 and move the spectrum analyzer test cable to the 41.25 IF output jack J16. Tune C59 and L17 to L20 to maximize the 41.25-MHz aural IF signal and minimize the out-of-band products. Adjust pot R97 for -20 dBm at J16.
 17. Reconnect the plug to J16 and move the spectrum analyzer test cable to IF output jack J20. Preset R62, the visual IF gain pot, to the middle of the range. Insert a multiburst test signal into the transmitter and observe the visual frequency response with the spectrum analyzer set at 1 dB/division. Tune R63 and C30, the IF frequency response adjustments, for a flat-frequency response (± 0.5 dB).
 18. While still monitoring J20 with a spectrum analyzer, readjust R62, visual IF gain, for a 0 dBm visual output level. Adjust R85, A/V ratio, for a minus 10 dB aural-to-visual ratio or to the desired A/V ratio. Reconnect the plug to J20.
 19. Using an input video test signal (the 5-step staircase) with 100 IRE white level, monitor TP2 with an oscilloscope. Set control R24, the sync clip, just below the point where sync clipping begins to occur. Similarly, set R20, the white clip, to just below the point at which the white video begins to clip.

5.1.4.5 (A4) Aural IF Synthesizer Board, 4.5 MHz (1265-1303; Appendix D)

1. To set up the test equipment for this board:
 - A. Connect the 600 Ω balanced audio output from an audio oscillator to the balanced audio input terminals of the tray at TB1-1 (+), TB1-2 (-), and TB1-3 (ground) on the rear chassis.
 - B. Connect the combined IF output at J21 (IF sample) on the clamp modulator board to the input of an IF splitter. Connect one output of the splitter to the video demodulator and the other output to the spectrum analyzer.
 - C. At the front of the demodulator, connect a short cable from the RF-out jack to the IF-in jack.
 - D. Connect a cable from the 600 Ω audio output jack of the demodulator to the input of an audio distortion analyzer.
2. Set the output frequency of the audio oscillator to 400 Hz and the output level to +10 dBm.

3. Center the aural carrier on the spectrum analyzer with the spectrum analyzer set to the following:

Frequency/Division – 10 kHz
Resolution bandwidth – 3 kHz
Time/Division – 50 msec
Trigger – Free run
 - A. Adjust L5 for approximately +3.5 VDC at TP2.
 - B. The green LED DS1 should be illuminated, indicating a locked condition. If not, retune L5 for a locked condition.
4. Adjust R13, balanced audio gain, on the aural IF synthesizer board for ± 25 -kHz deviation.
5. Check the distortion on the aural distortion analyzer (THD= $< 0.5\%$).
6. Disconnect the 600 Ω balanced audio input to the tray. Connect a 75 Ω stereo audio input (400 Hz at 1 Vpk-pk) to composite audio input jack J3 on the rear of the tray. Follow the procedure in the stereo generator instruction manual for matching the level of the generator to the exciter. Use R17 to adjust the composite audio gain.
7. Check the distortion level on the distortion analyzer (THD)= $< 0.5\%$

5.1.4.6 (A8) ALC Board (1265-1305; Appendix D) (Part 1 of 2)

Table 5-2 describes the functions of each LED on the ALC board (A8).

Table 5-2. ALC Board LEDs

LED	FUNCTION
DS1 (Red LED)	Indicates that an abnormally low IF signal level is present at IF input connector J1
DS2 (Red LED)	Indicates that the ALC circuit is unable to maintain the level requested by the ALC reference due to excessive attenuation in the linearity or the IF phase corrector signal path or because jumper W3 on J6 is in manual gain
DS3 (Red LED)	Indicates a video loss fault
DS4 (Red LED)	Indicates that a Mute command is present
DS5 (Green LED)	Indicates that the output from the modulator is selected as the input to the board

1. To align the ALC board, preset the following controls on the tray:
 - A. ALC Board (1265-1305)

Connect jumper W1 on J4 to disable, between pins 2 and 3 (to disable linearity correctors).
Connect jumper W3 on J6 to manual, between pins 2 and 3 (for manual gain control).

Adjust R87, manual gain pot, to mid-range.
 - B. IF Phase Corrector Board (1227-1250)

Move W2 on J9 to phase correction: enable. Move W3 on J10 to amplitude correction: disable.
2. The combined IF output of the sync tip clamp modulator board is cabled to jack J32 of the ALC board. Remove J32 from the board, and look to see if DS1, Input Fault, is

illuminated. Reconnect J32 and make sure that DS1 is extinguished.

3. Jumper W3 on J6 should be in the Manual position. Monitor jack J3 with a spectrum analyzer.
4. With a multiburst video signal present, tune C4 for a flat-frequency response of ± 0.5 dB.
5. Before proceeding with the second part of the ALC board alignment, check to see that the IF phase corrector board (1227-1250) is functioning properly.

5.1.4.7 (A9) IF Phase Corrector Board (1227-1250; Appendix D)

The signal level into the board should be approximately the same as the output of the board.

The IF input jack of the IF phase corrector board is fed from the J3 IF O/P jack of (A8) the ALC board. The IF output jack of the IF phase corrector board is fed to the J7 IF I/P jack of the ALC board (A8).

5.1.4.8 (A8) ALC Board, NTSC (1265-1305; Appendix D) (Part 2 of 2)

To align this board:

1. Input a multiburst video test signal. Connect a spectrum analyzer to J11. Tune C63 for a flat-frequency response of ± 0.5 dB.
2. Move the Operate/Standby switch on the front panel to the Operate position.
3. Place jumper W3 on jack J6 in the Manual mode and adjust R87 for 0.5 volts at TP4.
4. Place jumper W3 on J6 in the Auto mode and adjust the front panel power adjust control A20 fully CW.

If the (optional) remote power raise/lower kit is present, then adjust switch S1 on the board to maximum voltage at TP4. Adjust R74, the range adjust, for 1 volt at TP4.

5. Adjust the front panel power adjust control A20 for 0.5 VDC at TP4. If the (optional) remote power raise/lower kit is present, move switch S1 on the board to mid-range and then adjust (A20) the front panel power adjust control for 0.8 VDC at TP4.
6. Disconnect the plug that is on J12 (IF output) and monitor J12 with a spectrum analyzer. Verify an output of approximately 0 dBm. If necessary, adjust R99 to increase the output level. If less of an output level is needed, move jumpers J27 and J28 to pins 2 and 3 and then adjust R99. Reconnect J12.
7. Move W2 on J5 to the Cutback Enable position. Remove the input video signal and verify that the output of the transmitter drops to 25%. Adjust R71, the cutback level, if necessary. Restore the input video.

NOTE: The following step affects the response of the entire transmitter.

8. Connect a video sweep signal to the input of the tray. Monitor the output of the system with a spectrum analyzer. Adjust C71 with R103 and C72 with R106, as needed, to flatten the response. C71 and C72 adjust for the frequency of the correction notch being applied to the visual response of the transmitter. R103 and R106 are used to adjust the depth and width of the correction notch.
9. Refer to Section 5.5 of this chapter for the system alignment procedures for the linearity

correctors. Controls R13, R18, and R23, the magnitude controls, should be set fully CW. Controls R34, R37, and R40 are the linearity cut-in adjustments.

5.1.4.9 (A14-A1) Channel Oscillator Board, Dual Oven (1145-1201; Appendix D)

This board is mounted in (A14) the channel oscillator assembly (1145-1202). To align the board:

1. Connect the main output of the channel oscillator (J1) to a spectrum analyzer, tuned to the crystal frequency, and peak tuning capacitors C6 and C18 for maximum output. Tune L2 and L4 for maximum output. The output level should be about +5 dBm. The channel oscillator should maintain an oven temperature of 50° C.

If a spectrum analyzer is not available, connect a digital voltmeter (DVM) to TP1 on the x4 multiplier board. Tune capacitors C6 and C18 for maximum voltage, then also tune L2 and L4 for a maximum voltage output at TP1.

3. Connect the sample output of the channel oscillator (J2) to a suitable counter and tune C11, coarse adjust, and C9, fine adjust, to the crystal frequency.

NOTE: Do not repeak C6, C18, L2, or L4. This may change the output level.

NOTE: While adjusting C9 and C11 to the crystal frequency, the peak voltage monitored at TP1 of the x4 multiplier board should not decrease. If a decrease does occur, there may be a problem with the crystal. Contact Axcera Field Support for further instructions.

3. Reconnect the main output (J1) of the channel oscillator to the input (J1) of the x4 multiplier.

5.1.4.10 (A11-A1) x4 Multiplier Board (1174-1112; Appendix D)

While monitoring the board with a DC voltmeter, maximize each test point voltage by tuning the broadband multipliers in the following sequence:

1. Monitor TP1 with a DVM and tune C4 for maximum voltage. Monitor TP2 with a DVM and tune C6 and C10 for maximum voltage. Monitor TP3 with a DVM and tune C12; repeak C4, C6, and C10 for maximum voltage.
2. Connect a spectrum analyzer, tuned to four times the crystal frequency, to the x4 multiplier output jack J2. While trying to keep the out-of-band products to a minimum, monitor the output and peak the tuning capacitors for maximum output.

Connect a spectrum analyzer to J6 on board. Adjust C23 and C26 to determine the center frequency. Use C2 and C7 to locate the upper and lower channel-edge shaping. C24 is used to determine the channel bandwidth.

The output of the x4 multiplier connects to (A11-A1) the filter/mixer board.

5.1.4.11 (A11-A2) VHF Filter/Mixer Board (1150-1102; Appendix D)

To align the board:

1. Monitor J4, the LO output of the board, with a spectrum analyzer and adjust C12 and C18 for maximum output at the LO frequency and minimum out-of-band products. Adjust C13 and C17 for the best frequency response for the LO frequency.

2. Adjust C3 and C6 to determine the center frequency. Use C2 and C7 to locate the upper and lower channel-edge shaping. C4 is used to determine the channel bandwidth.

5.1.4.12 (A11-A3) High-Band VHF Filter/Amplifier Board (1064252; Appendix D)

The filter/amplifier board has been factory swept and adjusted for a 6-MHz bandwidth.

NOTE: This board should not be tuned without the proper equipment.

The filtered output connects to J1 of the board and is amplified by U1 to a nominal +12 dBm visual and +2 dBm aural level by adjusting R9. The output at J2 is fed to J4 on the A11 enclosure and from there to J15 on the rear of the tray.

To align the board, use a multiburst or sweep video signal inserted into the exciter tray.

Reconnect the cable from J6 to J1 on the filter/amplifier board. Monitor J2, the RF output of the board, and peak C17 for the maximum signal level. Tune manual gain adjust R9 for a +12 dBm peak visual output.

The VHF exciter tray is aligned and ready for normal operation.

5.2 (A6 and A7) VHF High Band Amplifier Tray (1301169; Appendix C)

The (A6 and A7) VHF high-band amplifier tray has been adjusted at the factory to meet all specifications, including phase adjustment to match the multiple trays in an amplifier array when they are combined. The tray should not need to be adjusted to attain normal operation. Any adjustments to the boards in this tray should be performed in the Manual Gain position, with S1 on (A13) the AGC control board (1142-1601) in Manual.

The idling current for the amplifier boards are adjusted with no RF drive applied. S1 should be in the Auto AGC position for the normal operation of the transmitter.

Connect a dummy load with a rating of a least 750 watts to J2, the RF output jack of the tray.

5.2.1 (A13) AGC Control Board (1142-1601; Appendix D)

Using a calibrated wattmeter, check that the tray is operating at the rated power. Remove cable connected to the forward power sample input jack J4 on the (A13) AGC control board (1142-1601). The output power level should drop to 20% because of the VSWR cutback setting and the VSWR LED DS4 should be illuminated. The front panel Module Status LED should not be lit.

Reconnect J4 on A13 and adjust R59 on the AGC control board to begin cutting back on the output power level when the reflected level increases above 20%.

In the Power Supply Voltage position, the front panel meter is calibrated to +28 VDC by adjusting pot R86 on the AGC control board.

5.2.2 (A1-A1) Phase Shifter Board (1198-1602; Appendix D)

There are no adjustments to (A1-A1) the phase shifter board (1198-1602). The front panel has adjustments for phase that are made during the amplifier array setup procedure.

5.2.3 (A2-A1) VHF Filter/Amplifier Board (1301178; Appendix D)

The (A2-A1) VHF filter/amplifier board has approximately 5 dB of gain. Tune the channel filter capacitors C20 and C29 (loading), C23 and C26 (center frequency), and C24 (coupling) at J6 on the board for the best response.

The idling current, no RF drive applied, of the device Q1 is set for 250 mA. To set the current, remove the RF drive, measure the voltage across R20 (two 1Ω resistors in parallel on the filter/amplifier board) and adjust R13 for .125 volts (using Ohms' Law: $[E=I \times R]$: $[E=250 \text{ mA} \times .5 \Omega]$: $E=125 \text{ mV}$).

5.2.4 (A2-A2) VHF High Band Amplifier Board (P10-VHF-H; Appendix D)

This board is supplied by Delta RF Technology, Inc. Refer to the data sheets in the subassembly section of this manual for more information. The board has approximately 19 dB of gain and the output is typically +31 dBm.

5.2.5 (A3-A1) Overdrive Protection Board (1198-1601; Appendix D)

The level of the RF input and output of the (A3-A1) overdrive protection board (1198-1601) should be +31 dBm during normal operation.

To set up the overdrive circuit, check that the output power level of the transmitter is at 100% and adjust R11 on the board for a reading of .4 VDC at TP1. Increase the output power level of the transmitter to 110%, sync only, and adjust R12 until the output power begins to drop off.

Return the output power level of the transmitter to 100%.

5.2.6 (A3-A2) VHF High Band Amplifier Board (P200-VHF-H; Appendix D)

This board is supplied by Delta RF Technology, Inc. Refer to the data sheets in the subassembly section of this manual for more information. The board has approximately 14 dB of gain and the output is typically +45 dBm.

5.2.7 (A3-A3) 3 Way Splitter Board (1301161; Appendix D)

This board contains no tuning adjustments. The board takes the +45 dBm input and splits it into three equal +40 dBm outputs.

5.2.8 (A4-A1 thru A3) VHF Output Amplifier Pallets (P400-VHF-H; Appendix D)

These boards are supplied by Delta RF Technology, Inc. Refer to the data sheets in the subassembly section of this manual for more information. Each board has approximately 13 dB of gain and the output is typically +53.3 dBm.

5.2.9 (A5-A1) 3 Way Combiner Assembly (1301157; Appendix D)

There are no adjustments to the (A5-A1) 3 way combiner assembly. The three +53.3 dBm inputs are combined to produce the 750 watts peak of sync + aural output (+57.8 dBm) at the RF output jack J5 of the combiner.

J5 of the combiner connects to J2 the RF Output Jack of the VHF Amplifier Tray.

5.2.10 Calibration of the Visual Plus Aural Output Power and VSWR Cutback of the VHF amplifier tray

Check that a dummy load of at least 750 watts is connected to the output of the tray that is to be calibrated. Place switch S1 on the AGC control board in the Manual position before beginning the setup.

To adjust the visual output power levels:

1. Remove the J16 cable from (A5) the sync tip clamp/modulator board (1265-1302) in the exciter tray. Set Manual AGC switch S1, on the (A13) AGC control board (1142-1601) in the VHF amplifier tray, to the Manual position.
2. Connect a sync and black test signal to the video input jack of the remote

interface panel. Switch the transmitter to the Operate position.

3. Adjust the manual gain pot R5 on the AGC control board for:

- Sync + black 0 IRE setup; wattmeter=360 watts
- Sync + black 7.5 IRE setup; wattmeter=325 watts

NOTE: The transmitter must have 40 IRE units of sync.

4. Obtain a zero span reference of the visual-only carrier on a spectrum analyzer. Replace the J16 connector on the sync tip clamp/modulator board in the exciter tray. Adjust R5 on the AGC control board until the same visual reference is obtained. Adjust R44 on the AGC control board for 100% Forward Power.
5. Lower the forward power reading to 80% on the front panel meter using R5, the manual gain adjust on the AGC control board. Adjust R65, the AGC fault adjust on the AGC control board, until the green Module LED DS3 on the front panel just begins to light. Use R5 to readjust the forward power to 100%.
6. Switch Off the tray and reverse the J6 and J7 cables on the 3 way combiner board. Switch On the tray and adjust the front panel meter, in the Reflected Output Power position, to a 100% reading using R53, the reflected power meter adjust on the AGC control board. Adjust the reflected output power to a 20% reading using R5 on the AGC control board. Adjust R59, the VSWR cutback adjust on the AGC control board, until the red VSWR Cutback LED DS4 on the front panel lights. This sets up the VSWR cutback circuitry.
7. Readjust R5 for 100% on the meter to achieve a 750 watts peak of sync

+ aural output. However, if the system requires less output power per amplifier tray, adjust each tray by the same amount to give the desired total output power.

Switch Off the tray and return the J6 and J7 cables on the 3 way combiner board back to their original positions. If the tray was originally operating below 100% output power, the AGC fault adjust was set for 20% below the operational % Output Power of the tray. See the Test Data Sheet for the transmitter for the actual readings for the tray.

Place S1 on the AGC control board in the AGC position. This is the normal operating position after the setup is completed.

There is a spare 1 amp and 10 amp fuse on the top, right-hand side of the tray. These are replacements for fuses on the current metering board.

The VHF high band amplifier tray is aligned, calibrated, and ready for normal operation. Repeat as needed for the other amplifier tray.

5.3 Phase and Gain Adjustment of the VHF Amplifier Trays

The following procedure was completed at the factory and should only be followed if one of the VHF amplifier trays is replaced.

Preset the phase and gain potentiometer on each VHF amplifier tray fully CCW. Switch the transmitter to Operate and adjust the gain pot on each tray for 25% Output Power. Adjust the phase control CW on the left VHF amplifier tray. If the % Visual Output Power goes up, continue to adjust the phase control until either the peak is reached or the end-of-travel is reached. If the % Output Power goes down, reset the phase control on the VHF amplifier tray fully CCW and repeat the above procedure with the phase control of the other amplifier tray.

If the end-of-travel is reached on the phase adjust, reset the phase control CCW and add a 2-inch length of cable to the input of the affected VHF amplifier tray at J1. Readjust the phase of that tray until a peak is reached or until the end-of-travel is achieved. If the end-of-travel is reached, repeat the above procedure and replace the 2-inch length of cable with a 4-inch length of cable. Once a peak has been reached, move the phase control that is fully CCW up two turns and repeak using the phase control on the other tray. This allows both trays to have some range of adjustment.

Adjust the gain of both VHF amplifier trays for 90% Tray Output Power. Readjust each phase control to peak the combined output; the phase should only have been slightly affected. Although it may take a few turns to notice a change, there should be a definite peak that is achieved while adjusting the phase of each tray. Raise or lower the output power of each tray to achieve 100% Output Power. The output power of each tray should be 90% to 100%.

5.4 IF Phase Corrector Adjustment

As shipped, the exciter was preset to include linearity (gain vs. level) and phase (phase vs. level) predistortion. The predistortion was adjusted to approximately compensate the corresponding non-linear distortions of the amplifier trays and should not require additional adjustments.

Locate (A9) the IF phase corrector board (1227-1250) mounted in the VHF exciter. The amplitude correction portion of the board is not utilized in this configuration. As a result, jumper W3 on J10 should be in the Disable position, to +6.8 VDC, and R35 and R31 should be fully counter-clockwise (CCW). R68 is the range adjustment and should be set in the middle of the range. The phase correction Enable/Disable jumper W2 on

J9 should be in the Enable position, to ground.

Switch the input video test source to select an NTSC 3.58-MHz modulated staircase or ramp test waveform. While changing the input signals, switch the transmitter to Standby. Set up the station demodulator and monitoring equipment to monitor the differential phase or intermodulation products of the RF output signal. There are three corrector stages on the IF phase corrector board, each with a magnitude and a threshold adjustment that are adjusted, as needed, to correct for any differential phase or intermodulation problems. Adjust the R3 threshold for the cut-in point of the correction and the R7 magnitude for the amount of the correction that is needed.

Jumper W1 on J8 is set to give the desired polarity of the correction shaped by the threshold R11 and the magnitude R15 adjustments. After setting the polarity, adjust the R11 threshold for the cut-in point of the correction and the R15 magnitude for the amount of the correction that is needed. Finally, adjust the R19 threshold for the cut-in point of the correction and the R23 magnitude for the amount of the correction that is needed.

NOTE: Adjusting these pots changes all visual parameters and should be done cautiously.

5.5 Linearity Corrector Adjustment

The IF linearity correction function consists of three non-linear cascaded stages, each having adjustable magnitude and threshold, or cut-in points, on the ALC board. The threshold adjustment determines at what IF signal level the corresponding corrector stage begins to increase gain. The magnitude adjustment determines the amount of gain change for the part of the signal that exceeds the corresponding threshold point. Refer to the VHF exciter tray

control locations drawing, ALC board (1265-1305), to find the adjustments for the first through third linearity corrector stages. Because the stages are cascaded, the order of correction is important. The first stage should cut in near white level, with the cut-in point of the next stage toward black, and with the last stage primarily stretching sync.

To adjust the linearity correctors from scratch, ensure that the transmitter is operating at full power with the desired A/V ratio. Check that jumper W1 on J4 of the ALC board is enabled between pins 1 and 2. Make sure that the ALC voltage is set to +0.8 VDC as monitored on the front panel meter in the ALC position.

Insert a modulated ramp video test signal into the transmitter. While changing the input signals, switch the transmitter to Standby. Demodulate the output signal of the transmitter and observe the waveform on a waveform monitor while also looking at the signal on a spectrum analyzer. On the IF ALC board (1265-1306), preset pots R34, R37, and R40 (threshold) fully CCW and the magnitude adjustments R13, R18, and R23 fully clockwise (CW). On the IF phase corrector board (1227-1250), preset pots R7, R15, R23, and R35 fully CW and R3, R11, R19, and R31 fully CCW.

Set the waveform monitor to differential step filter and the volts/division scale to .1 volts. Center the display to approximately the blanking level.

Gradually adjust pots R3, R11, and R19 clockwise on the IF phase corrector board, as needed, to minimize the observed thickness of the intermodulation as seen on the display.

Adjust pots R34, R37, and R40 clockwise on the IF ALC board, as needed, to give correction at sync or at low luminance levels as viewed at the left-most edge of the waveform monitor.

The intermodulation beat products between the colorburst and the aural carrier at 920 kHz above visual carrier should also be observed on the spectrum analyzer while performing the preceding adjustments. The frequency will vary for different video systems. When the adjustments are performed properly, the intermodulation products on the spectrum analyzer should be at least -52 dB down, with a red field input, from peak visual carrier. The intermodulation distortion as displayed on the waveform monitor should be no more than 1 IRE. Pot R31 on the IF phase corrector board is used for any extra intermodulation correction that may be needed.

NOTE: Any adjustments to the above pots affects other visual parameters and some slight adjustments of all of the pots may be needed to meet all specifications simultaneously.

If the transmitter is being driven very hard, it may not be possible to get enough sync stretch while maintaining a flat differential gain. In this case, some video sync stretch may be used from the sync tip clamp/modulator board; the sync stretch adjustment is R48.

Switch the transmitter to Standby.

5.6 Calibration of the Forward Output Power Level of the Transmitter

NOTE: Only perform the following procedure if the power calibration is suspect.

Preset R51, the aural null pot, located on the visual/aural metering board (1265-1309) in the VHF exciter, fully CCW. Adjust R48, the null offset pot on the visual/aural metering board, for 0% Visual Output. Perform the following adjustments with no aural present. This is accomplished by removing jumper cable W1, the aural IF loop-through, that is connected to J16 on (A5) the sync tip clamp/modulator board (1265-1302)

located in the VHF exciter. Connect a sync and black test signal to the video input jack of the VHF exciter tray. Switch the transmitter to Operate.

Set up the transmitter for the appropriate average output power level: sync + black 0 IRE setup/wattmeter=595 watts; sync + black 7.5 IRE setup/wattmeter=545 watts.

Note: The transmitter must have 40 IRE units of sync.

Adjust R28, visual calibration, on (A19) the visual/aural metering board (1265-1309) for 100% on the front panel meter in the % Visual Output position.

With the spectrum analyzer set to the zero span mode, obtain a peak reference on the screen. Reconnect jumper cable W1 to J16 on (A5) the sync tip clamp/modulator board. While in the Visual Output Power position, adjust L3 for a minimum visual power reading. Turn the power adjust pot on the front panel until the original peak reference level is attained. Peak L1 and C8 for a maximum aural power reading and then also adjust R20 for a 100% Aural Power reading. Switch the transmitter to the Visual Output Power position and adjust R51, the aural null pot, for 100% Visual Power.

5.7 Calibration of the Reflected Output Level of the Transmitter

On the meter, in the Visual Power position, turn the power adjust pot to 20%. Check that the jumper is in Manual on (A11-A3) the VHF filter/amplifier board (1064252), located in the VHF exciter. Reverse the cables on A9, J3

and J4, and adjust R39 on the (A19) visual/aural metering board (1265-1309), in the VHF exciter, for a 20% reading in the Reflected Power position. At this 20% reference power reading, the VSWR LED mounted on the front panel of the exciter should be illuminated. If this LED is not lit, adjust R22 on the (A17) transmitter control board (1265-1311) in the VHF exciter tray until the VSWR LED just turns on. Turn the power adjust pot slightly CCW and the LED should go out. Turn the pot CW until the LED just turns on. The reflected output power is now calibrated.

Switch the transmitter to Standby. Move the cables on A9, J3 and J4, to their original positions. Switch the transmitter to Operate and adjust the front panel power pot for a 100% Visual Power reading.

5.8 (A8) 2-Way Combiner Assembly (1219-1006; Appendix C)

There are no adjustments to (A8) the VHF combiner assembly (1219-1006).

5.9 (A9) Bandpass Filter Assembly

NOTE: The bandpass filter is a pre-tuned vendor item and should not be tuned without the proper equipment. If tuning is required, consult the Axcera Field Support Department before attempting to make any adjustments.

This completes the alignment procedure for the 435B Transmitter. If a problem occurred during alignment, please contact Axcera field service department at 724-873-8100.

APPENDIX A
SYSTEM SPECIFICATIONS

Low Power VHF Transmitters/Translators 700W - 4kW



These low power VHF transmitters and translators deliver high quality and performance in a compact and economical package. The time-proven Axcera exciter provides a pre-corrected output directly to the high-gain final power amplifier modules.

Designed for high reliability and unattended operation, each power amplifier utilizes a parallel amplifier design with a high level of protection circuitry. Features such as VSWR cutback, overdrive protection and over-temperature protection ensure on-air reliability. Convenient system monitoring is achieved through front panel samples, status indicators and metering, most of which are remote controllable.

Low Power VHF Transmitters/Translators 700W - 4kW

Visual Performance

Frequency Range ¹	
300B	54 to 88 MHz
400B	174 to 216 MHz
Carrier Stability (<i>Transmitters or Translators w/FCR</i>)	
Standard	±250 Hz
w/PFC	±1 Hz
Frequency Translation Stability (<i>Translators</i>)	
Standard	±500 Hz
w/PFC	±1 Hz
Regulation of RF Output Power	3%
Output Variation (<i>Over 1 Frame</i>)	2%
Sideband Response	
-1.25 MHz and below	-20 dB
-0.75 to -0.5 MHz	+0.5 db, -2 dB
-0.5 to +3.58 MHz	±0.5 dB
+3.58 MHz to +4.18 MHz	+0.5, -1.0 dB
Freq Response vs. Brightness	±0.5 dB
Visual Modulation Capability	1%
Differential Gain	5%
Incidental Phase Modulation	±3°
Linearity (<i>Low Frequency</i>)	5%

Visual Performance (*continued*)

Differential Phase	±3°
Signal-to-Noise Ratio	55 dB
2t K-Factor	2%
Noise Factor (<i>Translators</i>)	5 dB (<i>Max</i>)
w/Input Preamp	3 dB (<i>Max</i>)
Input Dynamic Range (<i>Translators</i>)	-60 dB to
w/Input Preamp	-25 dBm
	-75 dBm
	to -30 dBm
Env. Delay (<i>Transmitters</i>)	Per FCC Standard
Video Input (<i>Transmitters</i>)	75 ohms
	(Loop through)
Harmonics	-60 dB or better
Intermodulation Products	-52 dB or better
Spurious (<i>≥ 3 MHz from channel edge</i>)	-60dB or better

Aural Performance

Frequency Deviation Capability (<i>Transmitters</i>)	±75 kHz
Distortion	0.5%
FM Noise	-60 dB
AM Noise	-55 dB
Aural to Visual Separation	4.5 MHz
	± 100Hz
Composite Audio Input (<i>Multi-channel sound</i>) (<i>Transmitters</i>)	
Input Level	1V peak, nominal
Input Impedance	75 ohms, unbalanced
Frequency Range	
±0.1 dB response	50 Hz to 50 kHz
±0.5 dB response	30 Hz to 120 kHz
Monaural Audio Input (<i>Transmitters</i>)	
Input Level	0 to +10 dBm
Input	600 ohms, balanced
Freq Range (<i>±0.5 dB resp.</i>)	30 Hz to 15 kHz
Pre-emphasis	75µs
Subcarrier Input (<i>Transmitters</i>)	
Input Level	1V peak, nominal
Input Impedance	75 ohms, unbalanced
Freq Range (<i>±0.5 dB resp.</i>)	20 kHz to 120 kHz

General

Model Number	325B/327B 425B/427B	330B/332B 430B/432B	334B/336B 434B/436B	335B-2.6 435B-2.6	335B-3.3 435B-3.3	335B-4 435B-4
Power Output (<i>Watts</i>)						
Visual (<i>Peak</i>)	700	1350	2000	2650	3300	4000
Aural (<i>Avg.</i>)	50	100	200	300	400	500
Output Connector	N	1 ⁵ / ₈ " EIA	1 ⁵ / ₈ " EIA	3 ¹ / ₈ " EIA	3 ¹ / ₈ " EIA	3 ¹ / ₈ " EIA
No. of PAS	1	2	3	4	5	6
Power Consumption (<i>Watts</i>)						
Grey	1800	3350	4900	6450	8000	9550
Sync & Black	2250	4250	6250	8250	10,250	12,250
Input Power						
Line Voltage (<i>Volts</i>) ¹	208 or 240 ± 10%					
Power Requirements	Single Phase, 50 or 60 Hz					
Size (<i>H x W x D</i>)	69"x22"x34"			69"x44"x34"		
Operational Temperature Range	0 to +50°, derate 2°C/1000 ft.					
Maximum Altitude ¹	8500 feet (2600m) AMSL					
Operational Humidity Range	0% to 95% non-condensing					
RF Load Impedance	50 Ω					

¹ Consult factory for other frequencies, altitudes and line voltages

Specifications published here are current as of the date of publication of this document. Because we are continuously improving our products, Axcera reserves the right to change specifications without prior notice. At any time, you may verify product specifications by contacting our office. Axcera views its patent portfolio as an important corporate asset and vigorously enforces its patents. Products or features contained herein may be covered by one or more U.S. or foreign patents.

APPENDIX B

SAMPLE LOG REPORT SHEET
& TYPICAL OPERATIONAL READINGS

(A4) VHF Exciter

ALC (0 to 1 V) = _____V % Aural Power (0 to 120) = _____%
% Exciter (0 to 120) = _____% Video (0 to 1 V) = _____IRE
% Reflected (0 to 120) = _____% Audio (0 to 100 kHz) = _____kHz
% Visual Power (0 to 120) = _____%

VHF High Band Amplifier Trays

(A6)

(A7)

AGC Voltage (0 to 10 V) = _____V	AGC Voltage (0 to 10 V) = _____V
% Reflected Power (0 to 120) = _____%	% Reflected Power (0 to 120) = _____%
% Output Power (0 to 120) = _____%	% Output Power (0 to 120) = _____%
Power Supply Voltage (0 to 100 V) = ____V	Power Supply Voltage (0 to 100 V) = ____V
AGC Sample = _____V	AGC Sample = _____V
Current I ₁ = _____A	Current I ₁ = _____A
Current I ₂ = _____A	Current I ₂ = _____A
Current I ₃ = _____A	Current I ₃ = _____A
Current I _D = _____A	Current I _D = _____A

VHF High Band Amplifier Trays

(A13)

(A14)

AGC Voltage (0 to 10 V) = _____V

AGC Voltage (0 to 10 V) = _____V

% Reflected Power (0 to 120) = _____%

% Reflected Power (0 to 120) = _____%

% Output Power (0 to 120) = _____%

% Output Power (0 to 120) = _____%

Power Supply Voltage (0 to 100 V) = ____V

Power Supply Voltage (0 to 100 V) = ____V

AGC Sample = _____V

AGC Sample = _____V

Current I_1 = _____A

Current I_1 = _____A

Current I_2 = _____A

Current I_2 = _____A

Current I_3 = _____A

Current I_3 = _____A

Current I_D = _____A

Current I_D = _____A

Date _____

Customer Name _____ Call Letters _____

Technician _____

(A4) VHF Exciter

ALC = .8 VDC

% Aural Power = 100 % (265 Watts @ 10 dB A/V Ratio)

% Exciter = The level needed to attain 100% output power from the transmitter (Typically between 80 & 90%)

Video = 1 V at White w/.3V Sync Only, -40 IRE

% Reflected = < 10 %

Audio = ±25 kHz with Balanced Audio Input or ±75 kHz with Stereo Composite Audio Input

% Visual Power = 100 % (2650 Watts Peak of Sync)

VHF High Band Amplifier Trays

(A6)(A7)

(A13)(A14)

AGC Voltage (0 to 10 V) = 1-2V

AGC Voltage (0 to 10 V) = 1-2V

% Reflected Power (0 to 120) = <10%

% Reflected Power (0 to 120) = <10%

% Output Power (0 to 120) = 90%

% Output Power (0 to 120) = 90%

Power Supply Voltage (0 to 100 V) = +28V

Power Supply Voltage (0 to 100 V) = +28V

Current I₁ = 10 Amps

Current I₁ = 10 Amps

Current I₂ = 10 Amps

Current I₂ = 10 Amps

Current I₃ = 10 Amps

Current I₃ = 10 Amps

Current I_D = 5 Amps

Current I_D = 5 Amps

APPENDIX C
SYSTEM DRAWINGS

430B System:

2650-Watt VHF Transmitter Block Diagram 1308029
2650-Watt VHF Transmitter Interconnect..... 1307863
2650 Watt VHF Transmitter Racking Plan..... 1307863

AC Distribution Assembly

Interconnect 1265-8600

VHF High Band Exciter Tray, M/N, Sync Tip Clamp

Block Diagram 1070906
Interconnect 1070908

VHF High Band Amplifier Tray

Block Diagram 1301111
Interconnect 1301078

4-Way Combiner Assembly, VHF High Band

Interconnect 1307921

APPENDIX D
SUBASSEMBLY DRAWINGS

AGC Control Board	
Schematic.....	1142-3601
Channel Oscillator Board, Dual Oven	
Schematic.....	1145-3201
VHF Filter/Mixer Board	
Schematic.....	1150-3102
(Optional) IF Attenuator Board (Part of AM Identifier Kit)	
Schematic.....	1150-3201
x4 Multiplier Board	
Schematic.....	1174-3112
IF Carrier Oven Oscillator Board, 45.75 MHz	
Schematic.....	1191-3404
Overdrive Protection Board	
Schematic.....	1198-3601
Phase Shifter Board, VHF High Band	
Schematic.....	1198-3603
Delay Equalizer Board	
Schematic.....	1227-3204
(Optional) Composite 4.5-MHz Filter Board (Part of 4.5MHz Input Kit)	
Schematic.....	1227-3244
IF Phase Corrector Board	
Schematic.....	1227-3250
Sync Tip Clamp/Modulator Board	
Schematic.....	1265-3302
Aural IF Synthesizer Board, 4.5 MHz	
Schematic.....	1265-3303
ALC Board	
Schematic.....	1265-3305
(Optional) 4.5-MHz Bandpass Filter Board (Part of 4.5MHz Input Kit)	
Schematic.....	1265-3307
(Optional) EEPROM FSK Identifier Board (Part of AM Identifier Kit)	
Schematic.....	1265-3308
Visual/Aural Metering Board	
Schematic.....	1265-3309
Transmitter Control Board	
Schematic.....	1265-3311

+12V(4A)/-12V(1A) Power Supply Board Schematic.....	1265-3312
VHF High-Band Filter/Amplifier Board Schematic.....	1064147
VHF Mixer/Amplifier Enclosure Assembly Interconnect.....	1088069
VHF Filter/Amplifier Board Schematic.....	1301179
Current Metering Board, VHF High Band Schematic.....	1301317
P10-225 VHF-H 10W Pk. Sync VHF HB Pallet (1207056). Delta RF Technology Data Sheet.....	(P10-VHF-H)
P200-VHF-H 200W Pk. Sync VHF HB Pallet (1300167) Delta RF Technology Data Sheet.....	(P200-VHF-H)
P400-VHF-H 400W Pk. Sync VHF HB Pallet (1301322) Delta RF Technology Data Sheet.....	(P400-VHF-H)