

**Innovator,
CU5-1800BTD/BRD,
ATSC Transmitter/
Regenerative Translator**

Axcera, LLC
103 Freedom Drive, P.O. Box 525 Lawrence, PA 15055-0525 USA
PHONE: 1-724-873-8100 • FAX 1-724-873-8105
www.axcera.com • info@axcera.com



Table of Contents

Introduction	1
<i>Manual Overview</i>	1
<i>Assembly Designators</i>	1
<i>Safety</i>	1
<i>Contact Information</i>	2
<i>Return Material Procedure</i>	2
<i>Limited One Year Warranty for Axcera Products</i>	3
Unpacking and Installation	11
<i>Unpacking</i>	11
<i>Installation</i>	11
Tray Slide Installation	12
AC Input Connections	12
Input and Output Connections	14
Initial On Site Turn On Procedure	18
Typical System Operating Parameters	19
Typical Problems, Indications and Causes	20
LCD Display and Front Panel LED Indicators	21
System Remote Connections	22
LCD Front Panel Screens	24
<i>Operation Screens</i>	25
<i>Set Up Screens</i>	30
System Description	36
(Optional) Innovator CXB Series Web Ethernet Interface	38
Circuit Descriptions of Boards in the CU5, CU30, CU50, CU100 & CU125 Systems	42
(A1) <i>8 VSB Demodulator Board (1308275) - Only used with BRD operation</i>	42
Overview	42
Microcontroller Functions	42
Jumper and DIP Switch Settings	42
(A2) <i>Digital Modulator Board (1304883), Part of the Digital Modulator</i>	42
w/Power Conditioner (1309629)	42
SMPTE-310 Input	42
Channel Coder	43
Analog Output Section	43
Pilot Frequency Generation	43
Voltage Requirements	43
(A3) <i>IF Pre-Corrector Board (1308796)</i>	44
Pin-Diode Attenuator Circuit	44
In Phase and Quadrature Corrector Circuits	45
Frequency Response Corrector Circuit	46
ALC Circuit	46
Input Fault and Modulation Fault Circuitry	47
±12 VDC, +6.8 VDC, and VREF needed to operate the Board	47
(A4) <i>Frequency Agile Upconverter Board (1309695)</i>	48
(A5) <i>ALC Board, Innovator CX Series (1308570)</i>	49
(A6) <i>Amplifier Assembly (1309621) - Used in the CU5</i>	50
(A6-A1) <i>2 Stage UHF Amplifier Board, 24V (1309608)</i>	50
(A6) <i>Amplifier Assembly (1312566) - Used in the CU30 and CU50</i>	51
(A6-A1) <i>2 Stage UHF Amplifier Board (1308784)</i>	51
(A6-A2) <i>RF Module Pallet w/Philips Transistors (1300116)</i>	51
(A6) <i>Amplifier Assembly (1312191) - Used in the CU100 & CU125</i>	52
(A6-A1) <i>1 Watt UHF Amplifier Module (1310282)</i>	52

(A6-A2) BL871 Single Stage Amplifier Board (1311041).....	52
(A6-A3) Dual 878 Pallet Assembly (1310138)	52
(A7) Output Detector Board (1308685 or 1312207 in the CU100BTD/BRD).....	53
(A8) Control Card, Innovator CX (1312543).....	53
(A9 & A10) Power Supplies used in CU5, CU30, CU50, CU100 & CU125 and Driver for CU250 & higher power	54
Circuit Description of External Board only used in CU250 and higher power Transmitters with external amplifier trays	54
(A5) System Metering Board (1312666)	54
Circuit Descriptions of Boards in the CU250, 250 Watt and CU500, 500 Watt ATSC Amplifier Trays	55
(A7) Amplifier Control Board (1312260)	55
(A10) Current Metering Board (1309130)	55
(A5) 4 Way Splitter Board (1308933).....	56
(A1-A4) 878 Amplifier Pallets (1310138)	56
(A6) 4 Way Combiner Board (1312368)	56
(A8 & A9) 250 Watt and 500 Watt Amplifier Tray Power Supplies	56
(Optional) ASI to S310 Converter Module	57
ASI Motherboard (1311179)	57
ASI to 310 Conversion Board, Non-SFN (1311219)	57
System Set Up Procedure	58
Set Up of the LO1 and LO2 Samples on Upconverter Board.....	58
Set Up of the IF Precorrector Board in the System	59
ALC Board Set-Up, Forward and Reflected Power Calibration for CU5, CU30, CU50, CU100 and CU125 Systems	60
Forward and Reflected Power Calibration of CU250 and Higher Power Systems.....	61
Linearity Correction Adjustment (Non-Linear Distortions)	62
Linearity Correction Adjustment (Linear Distortions)	63
APPENDIX A	1
Innovator CXB Series System Drawing List.....	1
APPENDIX B	1
Specifications Sheet.	2

Introduction

Manual Overview

This manual contains the description of the Innovator CU5-1800BTD/BRD ATSC Transmitter/Regenerative Translator and the circuit descriptions of the boards, which make up the system. The manual also describes the installation, setup and alignment procedures for the system. Appendix A of this manual contains the system level drawings for the Innovator CU5-1800BTD/BRD ATSC Transmitter/Regenerative Translator. **NOTE:** Information and drawings on the Axciter, if part of your system, are contained in the separate Axciter Instruction Manual.

Assembly Designators

Axcera has assigned assembly numbers, Ax designations such as A1, where x=1,2,3...etc, to all assemblies, modules, and boards in the system. These designations are referenced in the text of this manual and shown on the block diagram and interconnect drawings provided in Appendix A.

The cables that connect between the boards within a tray or assembly and that connect between the trays, racks and cabinets are labeled using Brady markers. Figure 1 is an example of a Brady marked cable. There may be as few as two or as many as four Markers on any one cable. These Brady markers are read starting furthest from the connector. If there are four Brady Markers, this marker is the system number such as system 1 or translator 2. The next or the furthest Brady Marker is the rack or cabinet number on an interconnect cable or the board number within a tray. The next number on an interconnect cable is the Tray location or number. The Brady marker closest to the connector is the jack or connector number on an interconnect cable or the jack or connector number on the board within a tray.

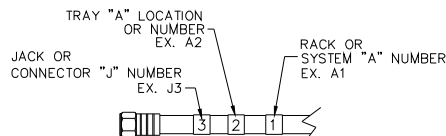

Figure 1: Brady Marker Identification Drawing

Safety

The Innovator CU5-1800BTD/BRD ATSC Transmitter/Regenerative Translator systems manufactured by Axcera are designed to be easy to use and repair while providing protection from electrical and mechanical hazards. Please review the following warnings and familiarize yourself with the operation and servicing procedures before working on the system.

Read All safety Instructions – All of the safety instructions should be read and understood before operating this equipment.

Retain Manuals – The manuals for the system should be retained at the system site for future reference. Axcera provides two manuals for this purpose; one manual can be left at the office while the other can be kept at the site.

Heed all Notes, Warnings, and Cautions – All of the notes, warnings, and cautions listed in this safety section and throughout the manual must be followed.

Follow Operating Instructions – All of the operating and use instructions for the system should be followed.

Cleaning – Unplug or otherwise disconnect all power from the equipment before cleaning. Do not use liquid or aerosol cleaners. Use only a damp cloth for cleaning.

Ventilation – Openings in the cabinet and module front panels are provided for ventilation. To ensure the reliable operation of the system, and to protect the unit from overheating, these openings must not be blocked.

Servicing – Do not attempt to service this product yourself until becoming familiar with the equipment. If in doubt, refer all servicing questions to qualified Axcera service personnel.

Replacement Parts – When replacement parts are used, be sure that the parts have the same functional and performance characteristics as the original part. Unauthorized substitutions may result in fire, electric shock, or other hazards. Please contact the Axcera Technical Service Department if you have any questions regarding service or replacement parts.

Contact Information

The Axcera Field Service Department can be contacted by PHONE at **1-724-873-8100** or by FAX at **1-724-873-8105**.

Before calling Axcera, please be prepared to supply the Axcera technician with answers to the following questions. This will save time and help ensure the most direct resolution to the problem.

1. What are your Name and the Call Letters for the station?
2. What are the model number and type of system?
3. Is the system digital or analog?
4. How long has the system been on the air? (Approximately when was the system installed?)
5. What are the symptoms being exhibited by the system? Include the current front panel LCD readings and what the status LED is indicating on the front panel of the tray. If possible, include the LCD readings before the problem occurred.

Return Material Procedure

To insure the efficient handling of equipment or components that have been returned for repair, Axcera requests that each returned item be accompanied by a Return Material Authorization Number (RMA#). The RMA# can be obtained from any Axcera Field Service Engineer by contacting the Axcera Field Service Department at 1-724-873-8100 or by Fax at 1-724-873-8105. This procedure applies to all items sent to the Field Service Department regardless of whether the item was originally manufactured by Axcera.

When equipment is sent to the field on loan, the RMA# is included with the unit. The RMA# is intended to be used when the unit is returned to Axcera. In addition, all shipping material should be retained for the return of the unit to Axcera.

Replacement assemblies are also sent with the RMA# to allow for the proper routing of the exchanged hardware. Failure to close out this type of RMA# will normally result in the customer being invoiced for the value of the loaner item or the exchanged assembly.

When shipping an item to Axcera, please include the RMA# on the packing list and on the shipping container. The packing slip should also include contact information and a brief description of why the unit is being returned.

Please forward all RMA items to:

**AXCERA, LLC
103 Freedom Drive
P.O. Box 525
Lawrence, PA 15055-0525 USA**

For more information concerning this procedure, call the Axcera Field Service Department at 1-724-873-8100.

Axcera can also be contacted through e-mail at **info@axcera.com** and on the Web at **www.axcera.com**.

Limited One Year Warranty for Axcera Products

Axcera warrants each new product that it has manufactured and sold against defects in material and workmanship under normal use and service for a period of one (1) year from the date of shipment from Axcera's plant, when operated in accordance with Axcera's operating instructions. This warranty shall not apply to tubes, fuses, batteries, bulbs or LEDs.

Warranties are valid only when and if (a) Axcera receives prompt written notice of breach within the period of warranty, (b) the defective product is properly packed and returned by the buyer (transportation and insurance prepaid), and (c) Axcera determines, in its sole judgment, that the product is defective and not subject to any misuse, neglect, improper installation, negligence, accident, or (unless authorized in writing by Axcera) repair or alteration. Axcera's exclusive liability for any personal and/or property damage (including direct, consequential, or incidental) caused by the breach of any or all warranties, shall be limited to the following: (a) repairing or replacing (in Axcera's sole discretion) any defective parts free of charge (F.O.B. Axcera's plant) and/or (b) crediting (in Axcera's sole discretion) all or a portion of the purchase price to the buyer.

Equipment furnished by Axcera, but not bearing its trade name, shall bear no warranties other than the special hours-of-use or other warranties extended by or enforceable against the manufacturer at the time of delivery to the buyer.

NO WARRANTIES, WHETHER STATUTORY, EXPRESSED, OR IMPLIED, AND NO WARRANTIES OF MERCHANTABILITY, FITNESS FOR ANY PARTICULAR PURPOSE, OR FREEDOM FROM INFRINGEMENT, OR THE LIKE, OTHER THAN AS SPECIFIED IN PATENT LIABILITY ARTICLES, AND IN THIS ARTICLE, SHALL APPLY TO THE EQUIPMENT FURNISHED HEREUNDER.

⚠ WARNING!!!

< HIGH VOLTAGE >

DO NOT ATTEMPT TO REPAIR OR TROUBLESHOOT THIS EQUIPMENT UNLESS YOU ARE FAMILIAR WITH ITS OPERATION AND EXPERIENCED IN SERVICING HIGH VOLTAGE EQUIPMENT. LETHAL VOLTAGES ARE PRESENT WHEN POWER IS APPLIED TO THIS SYSTEM. IF POSSIBLE, TURN OFF POWER BEFORE MAKING ADJUSTMENTS TO THE SYSTEM.

★ RADIO FREQUENCY RADIATION HAZARD ★

MICROWAVE, RF AMPLIFIERS AND TUBES GENERATE HAZARDOUS RF RADIATION THAT CAN CAUSE SEVERE INJURY INCLUDING CATARACTS, WHICH CAN RESULT IN BLINDNESS. SOME CARDIAC PACEMAKERS MAY BE AFFECTED BY THE RF ENERGY EMITTED BY RF AND MICROWAVE AMPLIFIERS. NEVER OPERATE THE TRANSMITTER SYSTEM WITHOUT A PROPERLY MATCHED RF ENERGY ABSORBING LOAD OR THE ANTENNA ATTACHED. KEEP PERSONNEL AWAY FROM OPEN WAVEGUIDES AND ANTENNAS. NEVER LOOK INTO AN OPEN WAVEGUIDE OR ANTENNA. MONITOR ALL PARTS OF THE RF SYSTEM FOR RADIATION LEAKAGE AT REGULAR INTERVALS.

EMERGENCY FIRST AID INSTRUCTIONS

Personnel engaged in the installation, operation, or maintenance of this equipment are urged to become familiar with the following rules both in theory and practice. It is the duty of all operating personnel to be prepared to give adequate Emergency First Aid and thereby prevent avoidable loss of life.

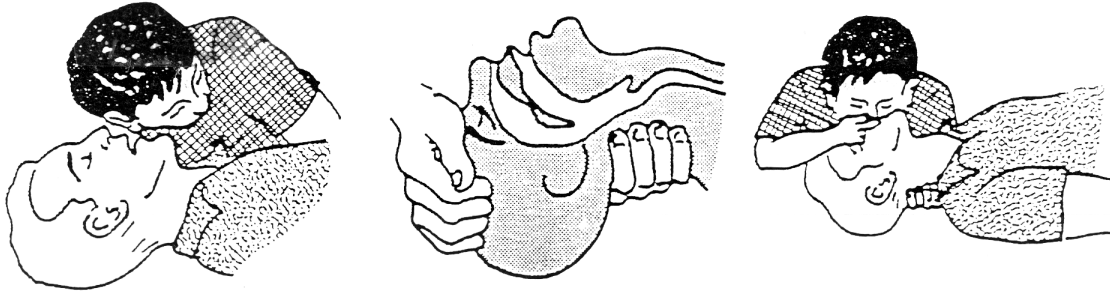

RESCUE BREATHING

1. Find out if the person is breathing.

You must find out if the person has stopped breathing. If you think he is not breathing, place him flat on his back. Put your ear close to his mouth and look at his chest. If he is breathing you can feel the air on your cheek. You can see his chest move up and down. If you do not feel the air or see the chest move, he is not breathing.

2. If he is not breathing, open the airway by tilting his head backwards.

Lift up his neck with one hand and push down on his forehead with the other. This opens the airway. Sometimes doing this will let the person breathe again by himself.

3. If he is still not breathing, begin rescue breathing.

-Keep his head tilted backward. Pinch nose shut.
-Put your mouth tightly over his mouth.
-Blow into his mouth once every five seconds
-DO NOT STOP rescue breathing until help arrives.

LOOSEN CLOTHING - KEEP WARM

Do this when the victim is breathing by himself or help is available. Keep him as quiet as possible and from becoming chilled. Otherwise treat him for shock.

BURNS

SKIN REDDENED: Apply ice cold water to burned area to prevent burn from going deeper into skin tissue. Cover area with a clean sheet or cloth to keep away air. Consult a physician.

SKIN BLISTERED OR FLESH CHARRED: Apply ice cold water to burned area to prevent burn from going deeper into skin tissue.

Cover area with clean sheet or cloth to keep away air. Treat victim for shock and take to hospital.

EXTENSIVE BURN - SKIN BROKEN: Cover area with clean sheet or cloth to keep away air. Treat victim for shock and take to hospital.

dBm, dBw, dBmV, dB μ V, & VOLTAGE EXPRESSED IN WATTS

50 Ohm System

WATTS	PREFIX	dBm	dBw	dBmV	dB μ V	VOLTAGE
1,000,000,000,000	1 TERAWATT	+150	+120			
100,000,000,000	100 GIGAWATTS	+140	+110			
10,000,000,000	10 GIGAWATTS	+130	+100			
1,000,000,000	1 GIGAWATT	+120	+ 99			
100,000,000	100 MEGAWATTS	+110	+ 80			
10,000,000	10 MEGAWATTS	+100	+ 70			
1,000,000	1 MEGAWATT	+ 90	+ 60			
100,000	100 KILOWATTS	+ 80	+ 50			
10,000	10 KILOWATTS	+ 70	+ 40			
1,000	1 KILOWATT	+ 60	+ 30			
100	1 HECTROWATT	+ 50	+ 20			
50		+ 47	+ 17			
20		+ 43	+ 13			
10	1 DECAWATT	+ 40	+ 10			
1	1 WATT	+ 30	0	+ 77	+137	7.07V
0.1	1 DECIWATT	+ 20	- 10	+ 67	+127	2.24V
0.01	1 CENTIWATT	+ 10	- 20	+ 57	+117	0.707V
0.001	1 MILLIWATT	0	- 30	+ 47	+107	224mV
0.0001	100 MICROWATTS	- 10	- 40			
0.00001	10 MICROWATTS	- 20	- 50			
0.000001	1 MICROWATT	- 30	- 60			
0.0000001	100 NANOWATTS	- 40	- 70			
0.00000001	10 NANOWATTS	- 50	- 80			
0.000000001	1 NANOWATT	- 60	- 90			
0.0000000001	100 PICOWATTS	- 70	-100			
0.00000000001	10 PICOWATTS	- 80	-110			
0.000000000001	1 PICOWATT	- 90	-120			

TEMPERATURE CONVERSION

$$^{\circ}\text{F} = 32 + [(9/5) ^{\circ}\text{C}]$$

$$^{\circ}\text{C} = [(5/9) (^{\circ}\text{F} - 32)]$$

USEFUL CONVERSION FACTORS

TO CONVERT FROM	TO	MULTIPLY BY
mile (US statute)	kilometer (km)	1.609347
inch (in)	millimeter (mm)	25.4
inch (in)	centimeter (cm)	2.54
inch (in)	meter (m)	0.0254
foot (ft)	meter (m)	0.3048
yard (yd)	meter (m)	0.9144
mile per hour (mph)	kilometer per hour(km/hr)	1.60934
mile per hour (mph)	meter per second (m/s)	0.44704
pound (lb)	kilogram (kg)	0.4535924
gallon (gal)	liter	3.7854118
U.S. liquid		
(One U.S. gallon equals 0.8327 Canadian gallon)		
fluid ounce (fl oz)	milliliters (ml)	29.57353
British Thermal Unit	watt (W)	0.2930711
		per hour (Btu/hr)
horsepower (hp)	watt (W)	746

NOMENCLATURE OF FREQUENCY BANDS

FREQUENCY RANGE	DESIGNATION
3 to 30 kHz	VLF - Very Low Frequency
30 to 300 kHz	LF - Low Frequency
300 to 3000 kHz	MF - Medium Frequency
3 to 30 MHz	HF - High Frequency
30 to 300 MHz	VHF - Very High Frequency
300 to 3000 MHz	UHF - Ultrahigh Frequency
3 to 30 GHz	SHF - Superhigh Frequency
30 to 300 GHz	EHF - Extremely High Frequency

LETTER DESIGNATIONS FOR UPPER FREQUENCY BANDS

LETTER	FREQ. BAND
L	1000 - 2000 MHz
S	2000 - 4000 MHz
C	4000 - 8000 MHz
X	8000 - 12000 MHz
Ku	12 - 18 GHz
K	18 - 27 GHz
Ka	27 - 40 GHz
V	40 - 75 GHz
W	75 - 110 GHz

RETURN LOSS VS. VSWR

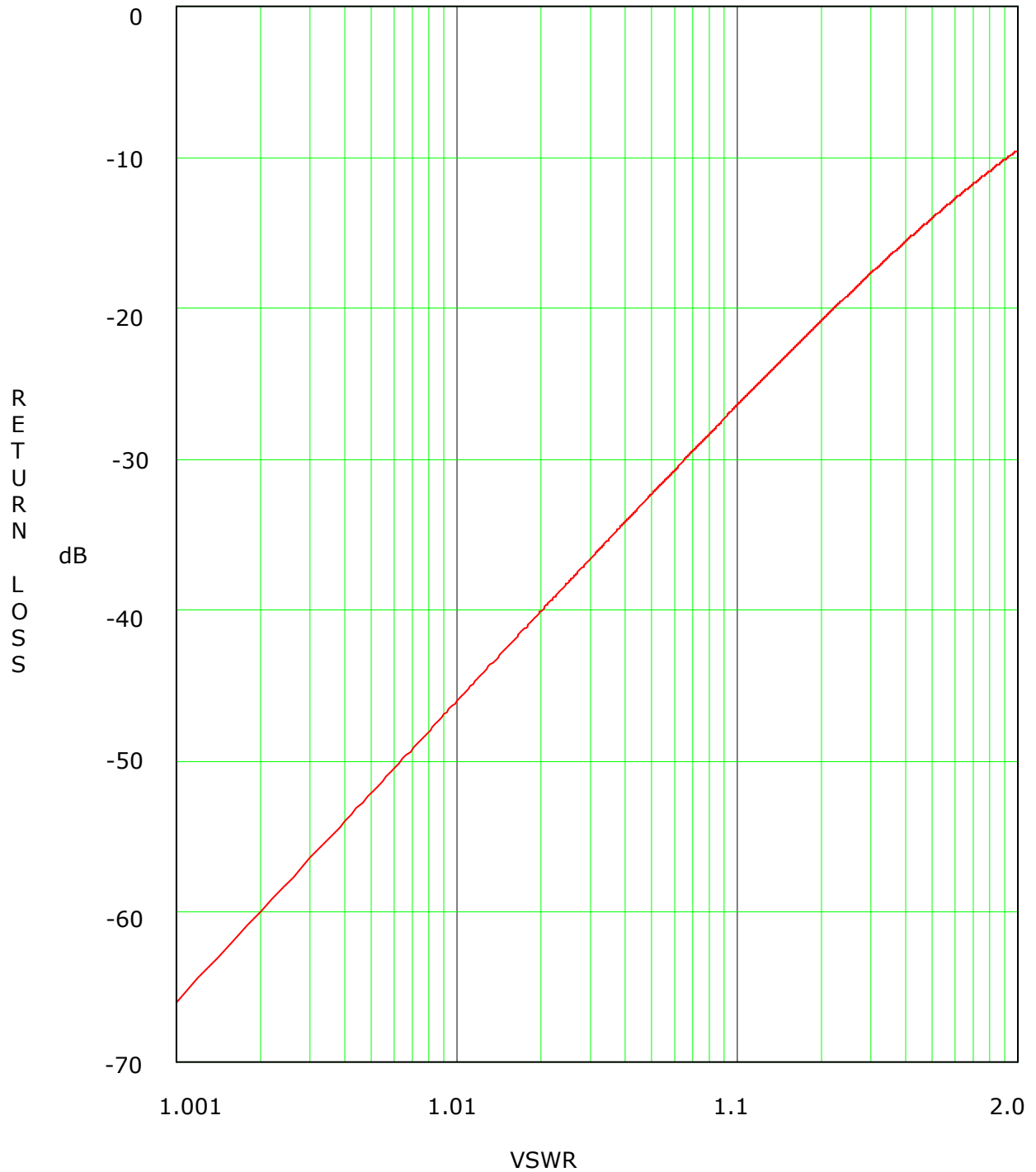

ABBREVIATIONS/ACRONYMS

AC	Alternating Current	dBmV	Decibel referenced to 1 millivolt
AFC	Automatic Frequency Control	dBw	Decibel referenced to 1 watt
ALC	Automatic Level Control	FEC	Forward Error Correction
AM	Amplitude Modulation	FM	Frequency Modulation
AGC	Automatic Gain Control	FPGA	Field Programmable Gate Array
ARD	A-line, Regenerative Translator, Digital	Hz	Hertz
ATD	A-line, Transmitter, Digital	ICPM	Incidental Carrier Phase Modulation
ATSC	Advanced Television Systems Committee (Digital)	I/P	Input
AWG	American Wire Gauge	IF	Intermediate Frequency
BER	Bit Error Rate	LED	Light emitting diode
BRD	B-line, Regenerative Translator, Digital	LSB	Lower Sideband
BTD	B-line, Transmitter, Digital	LDMOS	Lateral Diffused Metal Oxide Semiconductor Field Effect Transistor
BW	Bandwidth	MPEG	Motion Pictures Expert Group
COFDM	Coded Orthogonal Frequency Division Multiplexing modulation scheme	NTSC	National Television Systems Committee (Analog)
DC	Direct Current	O/P	Output
D/A	Digital to Analog	PLL	Phase Locked Loop
DSP	Digital Signal Processing	PCB	Printed Circuit Board
DTV	Digital Television	QAM	Quadrature Amplitude Modulation
dB	Decibel	SMPTE	Society of Motion Picture and Television Engineers
dBm	Decibel referenced to 1 milliwatt	VSB	Vestigial Side Band

This page intentionally left blank.

Unpacking and Installation

Unpacking

Axcera certifies that upon leaving our facility all equipment was undamaged and in proper working order. It is imperative that all packages be inspected immediately upon arrival to verify that no damage occurred in transit to the site. Inspect all packages for exterior damage and make note of any dents, broken seals, or other indications of improper handling. Carefully open each package and inspect the contents for damage. Verify that all materials are enclosed as listed on the packing slip. Report any shortages to Axcera. In the event any in transit damage is discovered, report it to the carrier. Axcera is not responsible for damage caused by the carrier. If the equipment is not going to be installed immediately, return all items to their original packaging for safe storage. Save all packing material for future use. If equipment is ever removed from the site, the original packaging will ensure its safe transport.

Installation

The Innovator CXB Series systems are designed for simple installation. Expensive test equipment is not required for installation and set up and to keep a system operational. Prior to installing the product, review the following items. Check that they have been installed, tested and/or inspected.

- Building Structure
- Electrical Systems
- Heating and Air Conditioning
- Receive Antenna or Satellite Dish and input cabling
- Optional ASI to S310 Converter if needed
- Transmit Antenna and output transmission line

The Innovator CXB Series systems are 17" (43.2cm) wide standard rack mountable trays. They are supplied with side mounted Tray Slides for ease of installation and removal. The CU5, CU30, CU50, CU100 & CU125 systems are 3 RU, 5.25" (13.3cm), high. The CU250 and CU500 systems are 9 RU, 15.75" (40cm) high, which is 3 RU, 5.25" (13.3cm) for the CU50 driver and 6 RU, 10.5" (26.7cm) for the 250 watt or the 500 Watt Innovator CXB Series amplifier tray. The CU1000 systems are 15 RU, 26.25" (66.7cm) high, which is 3 RU, 5.25" (13.3cm) for the CU50 driver and 12 RU, 21" (53.4cm) for the two Innovator CXB Series amplifier trays. The CU1500 systems are 21 RU, 36.75" (93.3cm) high, which is 3 RU, 5.25" (13.3cm) for the CU50 driver and 18 RU, 31.5" (80cm) for the three Innovator CXB Series amplifier trays. The CU1800 systems are 27 RU, 47.25" (120cm) high, which is 3 RU, 5.25" (13.3cm) for the CU50 driver and 24 RU, 42" (106.7cm) for the four Innovator CXB Series amplifier trays.

Also needed for FCC compliance operation is an ATSC filter on the broadcast channel that connects to the output of the CU5 thru CU1800 systems. Space must be provided for the ATSC filter and in some systems, for the splitter, combiner, and low pass filter whose dimensions will vary depending on manufacturer and channel. Refer to the vendor supplied information included with your ATSC filter for specific dimensions. In the CU250 and higher power systems, a low pass filter is connected after the amplifier tray(s) and the ATSC mask filter. Space must be provided for the low pass filter whose dimensions will vary depending on manufacturer and channel. Refer to vendor supplied information included with your low pass filter for specific dimensions. Make sure that the space provided for the CX Series equipment is sufficient and includes the splitters, combiners and external filters. Check that any additional equipment, which is included

in the system that extends above or to the side of the mounting rack, has sufficient clearance space. Refer to the custom racking plan for the system, if prepared, for detailed information.

Tray Slide Installation

If the system is pre-mounted in a cabinet skip this section. Locate the tray slides included in the installation material for your system. See Figure 2 and the manufacturers instructions, included with the tray slides, for the cabinet mounting instructions of the tray slides. Install the left tray slide into the left side of the cabinet (as viewed from the rear). Allow 3 RU, 5.25" (13.3cm) of space between the trays for a CU5, 30, 50, 100 or 125 systems. In high power systems, allow a space of 3 RU, 5.25" (13.3cm) for the CU50 driver and 6 RU, 10.5" (26.7cm) for each of the Innovator CXB Series amplifier trays in higher power systems. Space must also be provided for the splitter, combiner, ATSC filter and low pass filter, if present, whose dimensions will vary depending on the manufacturer and the output channel.

Secure the left tray slide by connecting it to the front and rear mounting bars using No. 10 screws and the bar nuts that have been provided. Install the tray slide on the right side of the cabinet (as viewed from the rear) making sure that it is aligned with the tray slide on the left side. Secure the slide by connecting it to the front and rear mounting bars using No. 10 screws and the bar nuts that have been provided. Repeat this process for any other trays if purchased. With both slides in place, slide the tray or trays into the cabinet.

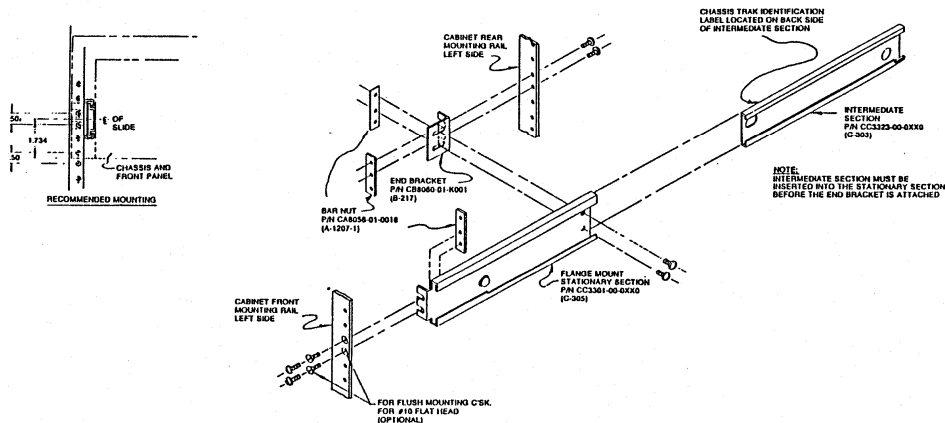

Figure 2: Chassis Trak Cabinet Slides

AC Input Connections

Refer to Figures 3 and 4 that follow for the location of the jacks and connectors of the system. The CU3, CU30, and CU50 systems will operate with an input voltage of 85-253VAC. CU100/125 systems operate on 185-253VAC. Check that the AC switch, located on the rear of the tray above the AC power jack, is OFF. Connect the AC power cord supplied with the tray from J6 on the rear of the tray to the AC source. If your system has the optional ASI to S310 Converter, check that it is connected to the AC source.

If your system is a CU250 or CU500, it also contains one 250 Watt or 500 Watt amplifier tray. In CU1000 and higher power systems, multiple 500 Watt amplifier trays are included. Each amplifier tray is configured for 230 VAC operation only. Check that the ON/OFF circuit breaker, located on the rear panel under the AC power jack, is OFF. Connect the AC power cord supplied with the tray from J10 on the rear of the tray to the

230 VAC source. Refer to Table 1 for the voltage and current requirements for CXB Systems.

Table 1: CXB Series Digital Systems Typical AC Input and Current Requirements.

System	O/P Power	Power Consumption	Voltage	Current
CU5	10 Watts	180 Watts	115 VAC	1.6 Amps to the Cabinet
			230 VAC	.8 Amps to the Cabinet
CU30	30 Watts	300 Watts	115 VAC	2.7 Amps to the Cabinet
			230 VAC	1.4 Amps to the Cabinet
CU50	50 Watts	475 Watts	115 VAC	4.2 Amps to the Cabinet
			230 VAC	2.1 Amps to the Cabinet
CU100	100 Watts	780 Watts	230 VAC	3.4 Amps to the Cabinet
CU125	125 Watts	900 Watts	230 VAC	4 Amps to the Cabinet
CU250	250 Watts	1700 Watts	230 VAC	7.4 Amps to the Cabinet
CU500	500 Watts	3400 Watts	230 VAC	14.8 Amps to the Cabinet
CU1000	1000 Watts	6300 Watts	230 VAC	27.4 Amps to the Cabinet
CU1500	1500 Watts	9700 Watts	230 VAC	42.2 Amps to the Cabinet
CU1800	1800 Watts	11000 Watts	230 VAC	47.9 Amps to the Cabinet

Input and Output Connections

The input and output connections to the system are made to the jacks mounted on the rear panels of the CU5 thru CU125 systems, the drivers for the CU250 and high power systems, and to the 250 Watt and 500 Watt amplifier trays. The CU5 thru CU125 systems and the drivers for the CU250 and higher power systems accept an On Channel RF signal (BRD) or a SMPTE-310 (BTD) input and output a digital RF ON Channel signal. Refer to Figure 3 and to Table 2 that follow for the locations and information on the jacks and connectors.

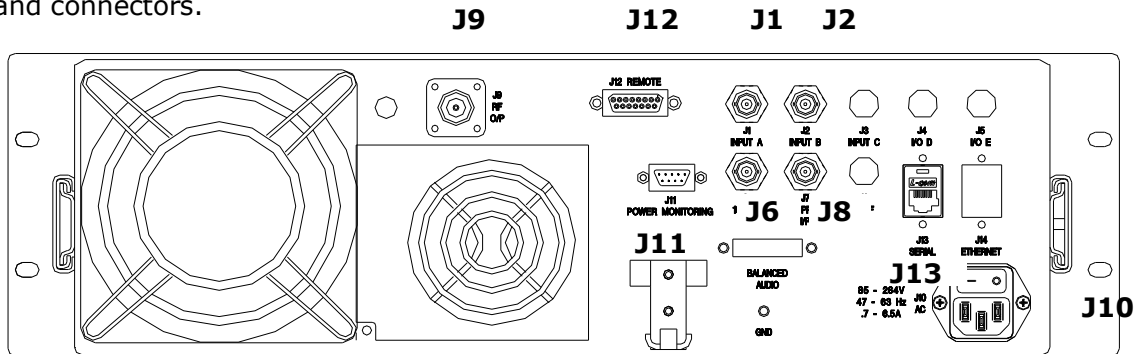

Figure 3: Rear View CU5 thru CU125 and the driver for the CU250 and higher power systems

Table 2: Connections for the CU5 thru CU125 and the driver for the CU250 & higher power Systems

Port	Type	Function	Impedance
J1	BNC	Input A: On Channel RF Input (BRD) -78 to -8 dBm or SMPTE-310 Input (BTD)	50 Ohms
J2	BNC	Input B: On Channel RF Input (BRD) -78 to -8 dBm or SMPTE-310 Input (BTD)	50 Ohms
J6	BNC	10 MHz Input: Optional External 10 MHz Reference Input	50 Ohms
J7	BNC	1 PPS Input: Optional External 1 PPS Reference Input	50 Ohms
J9	N	RF Output: On Channel RF Output	50 Ohms
J10	IEC	AC Input: AC input connection to 85-264VAC Source and On/Off circuit breaker	N/A

Port	Type	Function	Impedance
J11	9 Pos Male D	Power Monitoring: Interface to System and external amplifier trays, if present. Also provides an interlock for the Reject Load (if used).	N/A
J12	15 Pos Female D	Remote: Remote control and status indications	N/A
J13	RJ-45	Serial: Provides communication to System and to external amplifier trays, if present.	N/A
J14	RJ-45	Ethernet: Optional Ethernet connection. May not be present in your tray.	N/A
J15 Front Panel	BNC	RF Sample: Output Sample from Output Detector Board. In a CU30, CU50, CU100 & CU125, the sample level at J15 is approximately 60dB down from the output power level of the tray.	50 Ohms
J16 Front Panel	9 Pos Female D	Serial: Used to load equalizer taps into the modulator.	N/A

If your CU BTD system contains an Optional ASI to S310 Converter, connect the ASI output of the STL to the ASI in jack on the rear panel of the converter. Connect the SMPTE-310 Output from the SMPTE 310 Out jack on the rear panel of the converter module to the input jack J1 on the rear panel of the CU5 thru CU125 Tray and the Driver Tray for the CU250 and higher power systems.

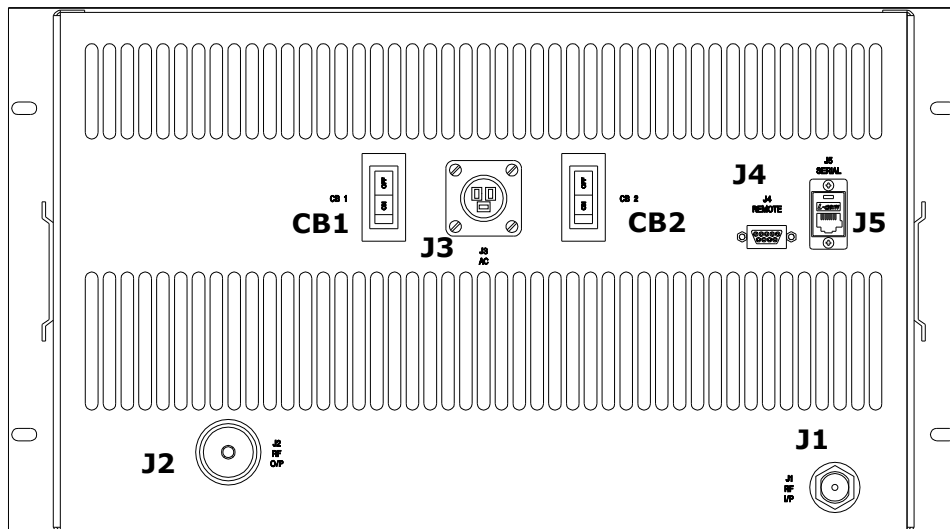

Figure 4: Rear View CU250 and CU500 Amplifier Tray

Table 3: Connections for the CU250 and CU500 Amplifier Tray

Port	Type	Function	Impedance
J1	N	RF Input: On Channel RF from CU driver tray	50Ω
J2	7/16" (1.1cm) Din	RF Output: On Channel RF Output	50Ω
J3	IEC	AC Input: AC input connection to 230VAC Source	N/A
J4	9 Pos D	Remote: Amplifier Control Interface (Connects to J11 on the driver tray)	N/A

Port	Type	Function	Impedance
J5	RJ-45	Serial data	N/A
J8 Front Panel	BNC	RF Sample: Output Sample from Combiner thru Control Board. In a CU500, the sample level is approximately 70dB down from the output power level of the tray.	50Ω

Refer to Figures 3 and 4, and Tables 2 and 3 for detailed information on the jacks and connectors. Connect the On Channel RF Input (BRD), -78 to -8 dBm, or the SMPTE-310 Input (BTD), to the 50Ω BNC input jack J1, located on the rear panel of the CU5 thru CU125 systems and the driver trays for the CU250 and higher power systems.

If used, connect the external 10 MHz reference input to the 50Ω BNC 10 MHz input jack J6 located on the rear panel of the CU5 thru CU125 systems and the drivers for the CU250 and higher power systems. If used, connect the external 1 PPS reference input to the 50Ω BNC 1 PPS input jack J7 located on the rear panel of the CU5 thru CU125 systems and the drivers for the CU250 and higher power systems.

The digital RF ON Channel output of the CU5 thru CU125 systems and the driver trays is at J9 the 50Ω "N" connector RF output jack located on the rear panel. In CU5 thru CU125 systems, the output of the tray at J9 connects to the digital mask filter and then to the antenna for your system. In CU250 and higher power systems, the output of the driver tray at J9 is connected to J1 the 50 Ohm "N" connector RF input jack located on the rear panel of the 250 Watt, 500 Watt amplifier tray or to a splitter in multiple amplifier systems. Check that the system power metering interface cable is connected from J11 the 9 position "D" connector located on the rear panel of the driver tray to J4 the 9 position "D" connector located on the rear panel of the 250 Watt or 500 Watt amplifier tray. This cable provides the control, status and operating parameters of the amplifier tray to the driver tray. The digital RF ON Channel output of the amplifier tray is at J2 the 50Ω "7/16" (1.1cm) Din connector RF output jack located on the rear panel that connects directly to the low pass filter, the digital mask filter and then to the antenna for your system in single amplifier systems or to a combiner and then the low pass filter, the digital mask filter and finally to the antenna in multiple amplifier systems.

This page intentionally left blank

Initial On Site Turn On Procedure

After the Innovator CXB Series tray or trays are installed and all input, output and AC connections are made, the system is ready for the initial on site turn on. Check that the output of the CU5, CU30, CU50, CU100, or CU125 tray is connected to an appropriate rated load or to the digital mask filter and the antenna for your system. If your system is a CU250 or higher power system, check that the output of the amplifier tray or the combiner assembly is connected to an appropriate rated load or to the low pass filter, the digital mask filter and the antenna for your system. Check that the main AC power to the System is ON.

If you have a CU5, CU30, CU50, CU100 or CU125 system, push ON the switch located on the rear panel of the tray above the AC power jack. The large fan mounted on the rear panel of the tray should operate. If your system is a CU250 or higher power system, switch ON the ON/OFF circuit breakers located on the rear panel of the amplifier tray(s) mounted on each side of the AC input power jack. The two fans mounted in the amplifier tray should operate.

The Operate/Standby LED and Status LEDs on the CU5, CU30, CU50, CU100 or CU125 should be Green indicating the system is in Operate and performing normally. The Operate/Standby LED showing Amber indicates the System is in Standby. The Status LED showing a blinking Red LED indicates a Fault is occurring now. The Status LED showing Amber indicates that a Fault occurred since the last time the Fault indications were reset.

If your system is CU250 or higher power, the Enable LED and Status LEDs on the 250 or 500 Watt Amplifier Tray should be Green indicating the system is in Operate and performing normally. The Enable LED showing Amber indicates the System is in Standby. The Status LED should be Green indicating no faults in system. If the Operate/Standby LED shows Amber it indicates that the System is in Standby. If the Status LED is blinking Red it indicates a Fault is occurring now. If the Status LED shows Amber it indicates that a Fault occurred since that last time the Fault indications were reset. The output power is factory set according to customer request and does not need adjusted. If a problem occurs, call Axcera field support at 1-724-873-8100 for information on modifying the power level of the system.

NOTE: The RF System Interlock is provided on J12, a D connector, located on the rear panel of the CU3, CU30, CU50, CU100 or CU125 tray. The RF System Interlock at J12-5 provides the customer with a means of connecting the system to protection circuits, for the loads, thermal switches, combiners, or the antenna, in the output of your system, that will place the system in Standby if the protection circuit opens. The Reject Load Interlock at J11-6 provides the customer with a means of connecting the system to protection circuits, for the reject load in multiple amplifier systems, which will place the system in Standby if the protection circuit opens. If the interlocks are not used in your system, a plug with a jumper from J11-5 to J11-9, ground, for RF system Interlock and another plug with a jumper from J11-6 to J11-9, for Reject Load Interlock, need to be connected. These jumpers provide the RF System and Reject Load Interlocks, which allow the system to go to operate. Without the jumpers, the system will remain in Standby.

Typical System Operating Parameters

Typical Operating Parameters for a CU3	
Parameter	Typical Reading
Forward Power	100%
Reflected Power	<5%
Power Supply Voltage	24 Volts
Heatsink Temperature	20° to 30° F above ambient temperature
Pin Attenuator Voltage	1 Volt to 5 Volts

Typical Operating Parameters for a CU30	
Parameter	Typical Reading
Forward Power	100%
Reflected Power	<5%
Power Supply Voltage	28 Volts
Heatsink Temperature	20° to 30° F above ambient temperature
Pin Attenuator Voltage	1 Volt to 5 Volts

Typical Operating Parameters for a CU50	
Parameter	Typical Reading
Forward Power	100%
Reflected Power	<5%
Power Supply Voltage	30 Volts
Heatsink Temperature	20° to 30° F above ambient temperature
Pin Attenuator Voltage	1 Volt to 5 Volts

Typical Operating Parameters for a CU100/125	
Parameter	Typical Reading
Forward Power	100%
Reflected Power	<5%
Power Supply Voltage	39 Volts
Heatsink Temperature	20° to 30° F above ambient temperature
Pin Attenuator Voltage	1 Volt to 5 Volts

Typical Operating Parameters for a CU50 used as a Driver	
Parameter	Typical Reading
Forward Power	20-70% (Depending on output power level of system)
Reflected Power	<3%
Power Supply Voltage	30 Volts
Heatsink Temperature	20° to 30° F above ambient temperature
Pin Attenuator Voltage	1 Volt to 5 Volts

Typical Operating Parameters for the external Amplifier Tray(s) in a CU250 or higher power System	
Parameter	Typical Reading
Forward Power	100%
Reflected Power	<5%
Power Supply Voltage	30 Volts
Heatsink Temperature	20° to 30° F above ambient temperature

Typical Problems, Indications and Causes

Problem	Indication	Cause
No power to tray	Operate/Standby and Enable LED indicators and LCD display are Off	AC power cord not connected. Main AC to System missing. On/Off switch on back of tray Off. 10 Amp fuse (F1) blown. Power supply (A9) not operating
Loss of Input Signal	Loss of Input on Modulator Menu	Loss of input signal.
Loss of Output Signal	Amber Operate/Standby LED. Blinking Red Status LED.	Any Fault that Mutes the output. Including Input Fault, VSWR Cutback, Overdrive, Overtemperature and Overvoltage.
Loss of 24V, 32V or 42V	Power Supply Fault on Power Supply Menu	Power supply (A10) not operating
Loss of ±12V or 5V	Operate/Standby and Enable LED indicators and LCD display are Off	Power supply (A9) not operating

NOTE: A spare 10 Amp fuse is provided in the blank fuse holder under the active fuse.

If there is a fault occurring in the system, the Status LED on the front panel will flash RED as long as the fault is present. In addition, the menu will jump to the current fault on the display and blink this fault continuously, if the Jump to Fault screen is set to Yes. When the fault is corrected, the tray will turn the Status LED to AMBER to indicate that there was a fault and the menu will still display the fault but it will not flash. This allows the user to know that there was a fault and what type of fault occurred. Before clearing the fault, check if there were other faults, by stepping through the menus. To reset the indication of previous faults, the user must push the Enter button with the Fault Reset Screen displayed. This will reset all previous Faults.

LCD Display and Front Panel LED Indicators

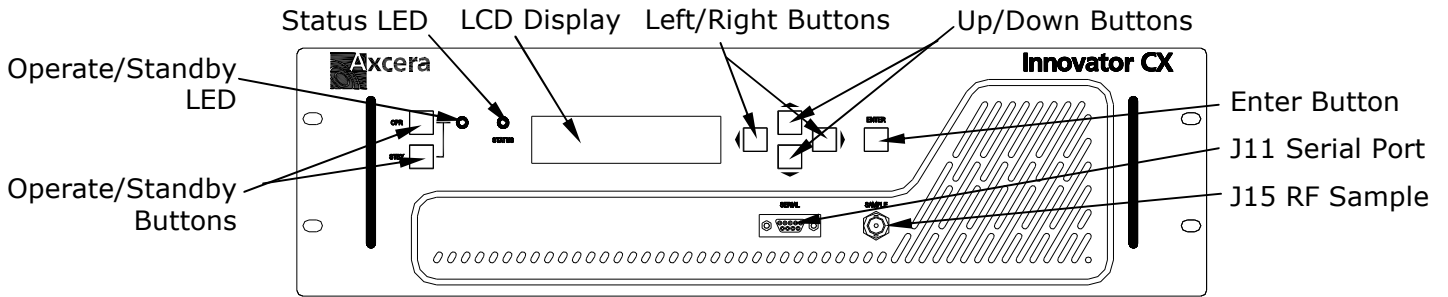

Figure 5: Front View CU5 thru CU125 systems and the driver for the CU250 & higher power

Table 4: Innovator CXB Series LCD Display

DISPLAY	FUNCTION
LCD	Provides a two-line readout of the input received channel, internal functions, status, and fault conditions.

The front panel has seven pushbuttons, two for the control of the system, Operate & Standby, and five for control of the displayed menus, Left, Right, Up, Down & Enter.

Table 5: Innovator CXB Series Control Pushbuttons

PUSHBUTTON	FUNCTION
OPR	When pushed switches the system to Operate.
STBY	When pushed switches the system to Standby.
ENTER	Selects the changes made in the menus and submenus.
Up & Down Arrow	Scrolls through the main menus and after entering the Main Menu Steps through submenus of the main menu when they are present.
Left & Right Arrow	Used to exit from main menus and submenus of the main menu when they are present.

Table 6: Innovator CXB Series Operate/Standby and Status Indicators

LED	FUNCTION
OPERATE/STANDBY (Green/Amber)	A Green LED indicates that the system is in Operate. An Amber LED indicates that the system is in Standby.
STATUS (Green/Red/Amber)	A Green LED indicates that the system is functioning normally. A flashing Red LED indicates a fault is occurring at this time. An Amber LED indicates a fault occurred since the last time the fault indications were reset but the system is now operating normally.

NOTE: J15 is a Front Panel BNC RF Sample Jack 50Ω that provides an RF output sample from the output detector board in the tray. In a CU50, the sample level at J15 is approximately 60dB down from the output power level of the tray.

System Remote Connections

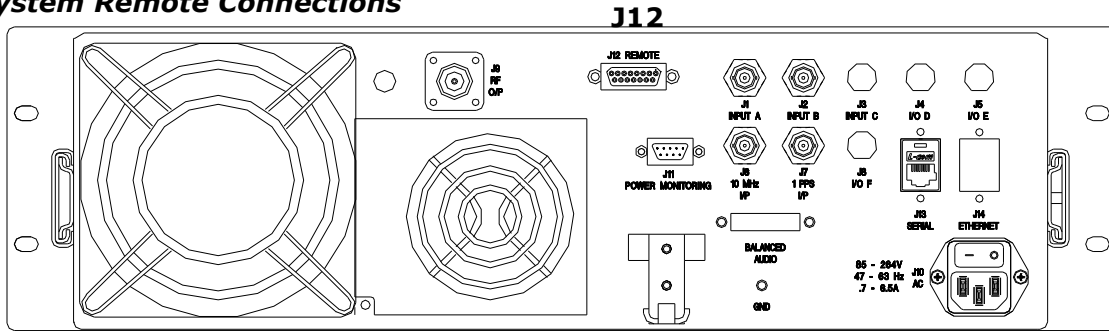

Figure 6: Rear View CU5 thru CU125 and the Driver for the CU250 & higher power

The remote connections for the Innovator CXB Series system are made to the Remote 15 Pos Female "D" connector Jack J12 located on the rear panel of the tray.

Table 7: Remote Connections to J12, 15 Pos Female D Connector, for CXB Series system

Signal Name	Pin Designations	Signal Type	Description
RMT System Operate	J12-1	Discrete Open Collector Input - A pull down to ground on this line indicates that the System is to be placed into the operate mode.	Command
RMT System Standby	J12-2	Discrete Open Collector Input - A pull down to ground on this line indicates that the System is to be placed into the standby mode.	Command
RMT Power Raise	J12-3	Discrete Open Collector Input - A pull down to ground on this line indicates that the Power of the System is to be Raised.	Command
RMT Power Lower	J12-4	Discrete Open Collector Input - A pull down to ground on this line indicates that the Power of the System is to be Lowered.	Command
RMT System Interlock	J12-5	Discrete Open Collector Input - A pull down to ground on this line indicates that the Interlock is present.	
RMT Set to Modulation Type	J12-6	Discrete Open Collector Input - A pull down to ground on this line indicates that the Modulation type is set to Analog, or floating sets to Digital.	Command
RMT Set Channel	J12-7	Not Used	Command
RMT Ground	J12-8	Ground	
RMT System Forward Power Level	J12-9	Analog Output - 0 to 4.0 V- This is a buffered loop through of the calibrated "System Forward Power". Indicates the System Forward power. Scale factor is 100 % = 2.0V.	Metering

Signal Name	Pin Designations	Signal Type	Description
RMT System Aural Power Level	J12-10	Analog Output - 0 to 4.0 V- This is a buffered loop through of the calibrated "System Aural Power". Indicates the System Aural power. Scale factor is 100 % = 2.0V. (Not used in Digital)	Metering
RMT System Reflected Power Level	J12-11	Analog Output - 0 to 4.0 V- This is a buffered loop through of the calibrated "System Reflected Power". Indicates the System Reflected power. Scale factor is 25 % = 2.0V.	Metering
RMT Input Status	J12-12	Discrete Open Collector Output - A low indicates that the Input to the System is OK. Floating indicates an Input Fault.	Status
RMT Fault Status	J12-13	Discrete Open Collector Output - A low indicates that the System is OK. Floating indicates a Fault has occurred.	Status
RMT Operate Status	J12-14	Discrete Open Collector Output - A low indicates that the System is in Standby. Floating indicates the System is in Operate.	Status
RMT Ground	J12-15	Ground	

LCD Front Panel Screens

A LCD display, located on the front of the Innovator CXB Series systems, displays, on screens, the current operating status of the system. When the tray is powered On, the LCD will initially display two splash screens. The first splash screen will be displayed for a few seconds, then the second splash screen will be displayed for a few seconds and finally the RF Power Display default screen will be displayed. See examples of the screens below. The RF Power Display default screen will be the screen displayed if no buttons are pushed to access other screens. While viewing the RF Power Display default screen, pushing the Left and Right arrow buttons together will also access the splash screens.

Splash Screen Number 1

```
AXCERA INNOVATOR  
MODEL CU1000BTD
```

The first splash screen displayed indicates the manufacturer, type and the model number.

Splash Screen Number 2

```
FIRMWARE 1312423  
VERSION 4.0f/1.F
```

The second splash screen indicates the Firmware and Version Numbers of the software used in the system. The example shown is Firmware number 1312423 Version number 4.0f/1.F.

The final screen is the RF Power default screen which indicates the Forward Power and Reflected Power for the system.

```
FWD POWER 100%  
RFL POWER 0.3%
```

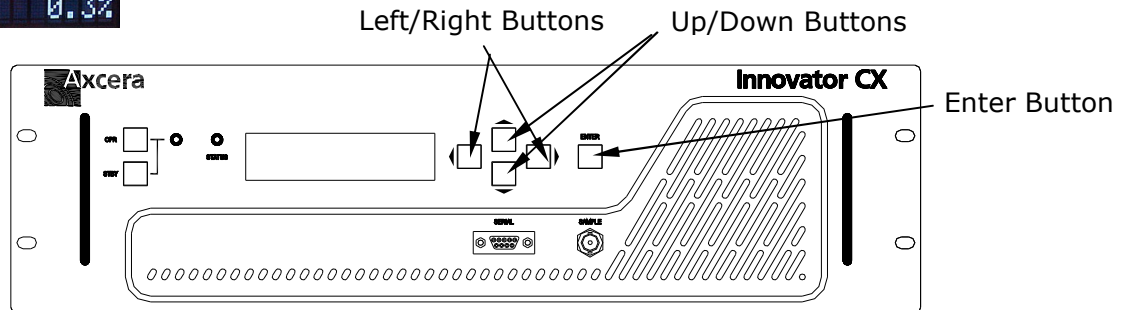

The following screens are scrolled through using the buttons to the right of the display. Pushing and releasing the Up & Down Arrows will scroll you through the Main Menus, which are shown on the following pages aligned on the left side of the page. The Submenus of the Main Menus are accessed by pushing and releasing the ENTER button. Once in the Submenu, pushing and releasing the Up & Down Arrows will scroll you through the submenus of the Submenus. The Submenus are shown on the following pages indented under the Main Menu and the submenus of the Submenus are indented under the Submenu in which they are contained. In the SET UP Menu, changes are made to the display by Pushing and releasing the ENTER button which causes the item to be changed to blink, then using the left and right arrow buttons to display the desired changed item, finally, pushing the ENTER button will accept the changes made upon exit of the Set Up Menu.

NOTE: An example of accessing and changing an item using the Set Up Menu is as follows. This procedure is to set the Off Air Receive Channel to the desired channel. Push and release the DOWN Arrow button until the SYSTEM SET UP Main Menu is displayed. Push and release the ENTER button. The Authorization Warning screen is displayed.

Push and release the ENTER button again and the ENTER BUTTON SETS TO CHANGE MODE screen is displayed. Push and release the ENTER button again and the first set up menu, which is the SET UP MENUS OF CHASSIS VALUES screen is displayed. Push and release the DOWN Arrow button until the SET UP 8VSB DEMODULATOR screen is displayed. Push and release the ENTER button to display the submenus under the SET UP 8VSB DEMODULATOR menu. Push and release the DOWN Arrow until the 8VSB DEMODULATOR USE OFF AIR CHxx is displayed. Push and release the ENTER button and the XX, which indicates the Channel Number, will blink. Push and release the UP or DOWN Arrow button until the new channel number is displayed. Push and release the ENTER button, and the PUSH ENTER TO ACCEPT CHANGES menu is displayed. Push and release the ENTER button again to accept the changes made. Push and release the LEFT Arrow to exit to the SET UP 8VSB DEMODULATOR screen. Push and release the LEFT Arrow again to exit to the SYSTEM SET UP Main Menu. Push and release the UP or DOWN arrows to browse the main menus.

The following screens are typical of an operating system. The values indicated on the screens in your system may vary from these.

Operation Screens

NOTE: The following Operation screens provide operating information only. No adjustments are available using these screens.

Table 8: Transmitter/Translator RF Power Screen (BTD/BRD)



```
FWD POWER 100%
RFL POWER 0.3%
```

This is the default screen that is displayed after the splash screens are displayed. This screen provides an indication of the Output Power of the system in terms of Percent. (Typically 100%). The screen also provides an indication of the Reflected Power of the system in terms of Percent. (Typically less than 5%). Push the DOWN Arrow to view the next main menu, which is the System Fault Log Main Menu.

Table 9: Transmitter/Translator Fault Log Main Screen (BTD/BRD)



```
TRANSMITTER
FAULT LOG
```

This is the System Fault Log Main Screen. Push the ENTER button to access the Fault List submenu or push the DOWN Arrow to view the next main menu, which is the System Details Main Menu.

Table 9.1: Transmitter/Translator Fault List Screen (BTD/BRD)



```
FAULT LIST EMPTY
```

If faults are present, they will be displayed on this screen. The above screen indicates no faults have occurred in the System. Push the LEFT Arrow to exit to the System Fault Log Main Menu screen.

Table 10: Transmitter/Translator Details Main Screen (BTD/BRD)



```
TRANSMITTER
DETAILS
```

This is the System Details Main Screen. Push the ENTER button to access the Device Details Chassis Values Main Sub Screen or push the DOWN Arrow to view the next main menu, which is the System Set Up Main Menu.

Table 10.1: Transmitter/Translator Device Details Exciter Values Screen (BTD/BRD)



This is the System Device Details Exciter Values Main Sub Screen. Push the ENTER button to access the Device Details Exciter Values submenus or push the DOWN Arrow to view the next main submenu, which is the 8VSB Demodulator Sub Menu.

Table 10.1.1: Transmitter/Translator Driver Forward/Reflected Power Details Screen (BTD/BRD)



This screen provides an indication of the Output Power of the Driver Tray in terms of Percent, typically 20-70%. This screen provides an indication of the Reflected Output Power of the Driver Tray in terms of Percent, Typically less than 3%.

Table 10.1.2: Heatsink Temperature Details Screen (BTD/BRD)



This screen indicates the temperature of the amplifier heatsink assembly, mounted in the system or driver tray, in degrees Fahrenheit. If the temperature is below the trip point, it will indicate OK. (Typically 20° to 30° F. above ambient temperature)

Table 10.1.3: Power Supply Voltage Details Screen (BTD/BRD)



This screen shows the power supply voltage in the system or driver tray. If the power supply voltage is below the trip point, it will indicate OK. (Typically 32V)

Table 10.1.4: RF System Interlock Details Screen (BTD/BRD)

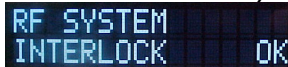

This screen indicates if the external RF system interlock is present in your system. (Typically Present. Must be present or system will remain in Standby.)

Table 10.1.5: Reject Load Interlock Details Screen (BTD/BRD)



This screen indicates if the external Reject Load interlock is present in your system. (Typically Present. Must be present or system will remain in Standby.)

Table 10.1.6: AGC Details Screen (BTD/BRD)



This menu indicates if the AGC circuit has an input.

Table 10.1.7: AGC Overdrive Details Screen (BTD/BRD)

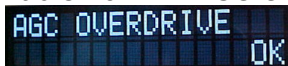

This menu indicates if the AGC circuit is operating within its range.

Table 10.1.8: AGC Auto/Manual Details Screen (BTD/BRD)



AGC AT S1 SET TO
AUTO MODE

This menu indicates if the AGC circuit is operating in Auto or Manual.

Table 10.1.9: ALC Voltage Level Details Screen (BTD/BRD)



ALC VOLTAGE AT
1.8 VDC

This menu indicates the Auto ALC voltage setting. (Typically 1 to 5 V)

Pushing the Left Arrow will display the System Device Details Exciter Values Main Sub Screen and then pushing the Down arrow will access the System Device Details 8VSB Demodulator Main Sub Screen.

Table 10.2: Translator 8VSB Demodulator Details Screen (BRD)



DEVICE DETAILS
8VSB DEMODULATOR

This is the System Device Details 8VSB Demodulator Main Sub Screen. Push the ENTER button to access the Device 8VSB Demodulator submenus or push the DOWN Arrow to view the next main menu, which is the Device Details 8VSB Modulator Main Sub Menu.

Table 10.2.1: System Input Details Screen (BRD)



SNR IS 32.2
INPUT PWR >95.0%

This screen provides the user information on the signal to noise ratio and signal strength of the received signal. The signal to noise ratio is provided on this menu to indicate to the user the quality of the receive signal. This reading also assists the user in the positioning of the antenna. The signal strength ranges from 0 to 100% and typically should be above 40% for reliable operation. The signal strength allows the user to optimize the position of the receive antenna.

Table 10.2.2: Demodulator Details Screen (BRD)



DEMODULATOR
INPUT OK

This menu indicates whether there is a signal present at the demodulator.

Table 10.2.3: Demodulator Phase Lock Loop Details Screen (BRD)



DEMODULATOR
PLL OK

This menu indicates whether the Phase Lock Loop is locked in the demodulator.

Table 10.2.4: Receive Input Channel Details Screen (BRD)

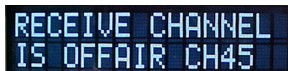

RECEIVE CHANNEL
IS OFFAIR CH45

This menu indicates the input channel to the Demodulator circuit.

Pushing the Left Arrow will display the System Device Details 8VSB Demodulator Values Main Sub Screen and then pushing the Down arrow will access the System Device Details 8VSB Modulator Main Sub Screens.

Table 10.3: Transmitter/Translator 8VSB Modulator Details Screen (BTD/BRD)

```
DEVICE DETAILS
8VSB MODULATOR
```

This is the System Device Details 8VSB Modulator Main Sub Screen. Push the ENTER button to access the Device 8VSB Modulator submenus or push the DOWN Arrow to view the next main menu, which is the Device Details IF Processor Main Sub Menu.

Table 10.3.1: Transmitter/Translator MPEG Input Details Screen (BTD/BRD)

```
INTERNAL SOURCE
MPEG INPUT    OK
```

This menu indicates if the modulator has locked to the SMPTE-310 signal coming from the demodulator.

Table 10.3.2: Modulator Phase Lock Loop A Details Screen (BTD/BRD)

```
MODULATOR
PLL A        OK
```

This menu indicates if the Phase Lock Loop A in the modulator is locked.

Table 10.3.3: Modulator Phase Lock Loop B Details Screen (BTD/BRD)

```
MODULATOR
PLL B        OK
```

This menu indicates if the Phase Lock Loop B in the modulator is locked.

Table 10.3.4: Modulator Linear Equalization Details Screen (BTD/BRD)

```
MODULATOR
LINEAR EQ    OFF
```

This menu indicates if the Linear Equalization is being used.

Table 10.3.5: Modulator Non Linear Equalization Details Screen (BTD/BRD)

```
MODULATOR
NONLINEAR EQ OFF
```

This menu indicates if the Non Linear Equalization is being used.

Pushing the Left Arrow will display the System Device Details 8VSB Modulator Values Main Sub Screen and then pushing the Down arrow will access the System Device Details IF Processor Main Sub Screen.

Table 10.4: Transmitter/Translator IF Processor Details Screen (BTD/BRD)

```
DEVICE DETAILS
IF PROCESSOR
```

This is the System Device Details IF Processor Main Sub Screen. Push the ENTER button to access the Device IF Processor submenus or push the DOWN Arrow to view the next main menu, which is the Device Details Upconverter Main Sub Menu.

Table 10.4.1: IF Processor Input Details Screen (BTD/BRD)

```
IF PROCESSOR
INPUT        OK
```

This menu indicates if there is an input signal to the IF Processor.

Table 10.4.2: IF Processor Modulation Present Details Screen (BTD/BRD)

```
IF PROCESSOR
MODULATION  OK
```

This menu indicates if there is Modulation on the signal to the IF Processor.

Pushing the Left Arrow will display the System Device Details IF Processor Values Main Sub Screen and then pushing the Down arrow will access the System Device Details Upconverter Main Sub Screen.

Table 10.5: Upconverter Device Details Screen (BTD/BRD)

```
DEVICE DETAILS
UPCONVERTER
```

This is the System Device Details Upconverter Main Sub Screen. Push the ENTER button to access the Device Upconverter submenus or push the DOWN Arrow to view the next main menu, which is the Device Details Downconverter Main Sub Menu.

Table 10.5.1: Upconverter Phase Lock Loop 1 Details Screen (BTD/BRD)

```
UPCONVERTER
PLL 1      OK
```

This menu indicates if the Phase Lock Loop 1 in the upconverter is locked.

Table 10.5.2: Upconverter Phase Lock Loop 2 Details Screen (BTD/BRD)

```
UPCONVERTER
PLL 2      OK
```

This menu indicates if the Phase Lock Loop 2 in the upconverter is locked.

Table 10.5.3: Upconverter 10 MHz Phase Lock Loop Details Screen (BTD/BRD)

```
UPCONVERTER
10MHz PLL  OK
```

This menu indicates if the 10 MHz Phase Lock Loop in the upconverter is locked.

Table 10.5.4: Upconverter 10 MHz Details Screen (BTD/BRD)

```
REFERENCE SOURCE
EXTERNAL 10MHz
```

This menu indicates if the 10 MHz reference used is generated internally or provided by an external reference source.

Table 10.5.5: Upconverter System Channel Details Screen (BTD/BRD)

```
TRANSMIT CHANNEL
CH15 1523.000MHz
```

The upconverter transmit channel screen indicates the channel and frequency that the upconverter is currently set.

Pushing the Left Arrow will display the System Device Details Upconverter Values Main Sub Screen and then pushing the Down arrow will access the System Device Details Downconverter Main Sub Screen.

Table 10.6: Downconverter Device Details Screen (BTD/BRD)



```
DEVICE DETAILS
DOWNCONVERTER
```

This is the System Device Details Downconverter Main Sub Screen. Push the ENTER button to access the Device Downconverter submenus or push the DOWN Arrow to go back to the Device Details Exciter Values screen.

Table 10.6.1: Downconverter RF Input Details Screen (BTD/BRD)



```
DOWNCONVERTER
RF INPUT 0.6dBm
```

The Downconverter RF Input details screen indicates that an RF input is present to the downconverter and the level of the input.

This is the final Device Details Main Sub Menu. Push the LEFT Arrow twice to go back the Main System Details Screen. Then push the DOWN Arrow to access the System Set Up Main Menu.

Set Up Screens

Table 11: Transmitter/Translator Set Up Main Screen (BTD/BRD)



```
TRANSMITTER
SET-UP
```

This is the System Set Up Main Screen. Push the ENTER button to access the Authorization Warning Main Sub Screen or since this is the final Main Screen, pushing the DOWN Arrow will take you back to the System RF Power Default Screen.

The Set Up item or parameter that can be changed on the displayed sub menu screen, is indicated by pushing the ENTER button, which causes the changeable item to blink. The UP or DOWN arrow will change the selection until the desired result is displayed. Pushing the ENTER Button will accept the change.

Table 11A: Authorized Personnel Screen (BTD/BRD)



```
PRESS ENTER ONLY
IF AUTHORIZED.
```

This screen of the system notifies an operator that they are only to proceed if they are authorized to make changes to the system's operation. Changes made within the following set-up screens can affect the system's output power level, output frequency, and the general behavior of the system. Please do not make changes within the system's set-up screens unless you are familiar with the operation of the system. Pressing the ENTER button will display the Enter Key Sets to Change screen.

Table 11B: Enter Key Sets to Change Mode Screen (BTD/BRD)



```
ENTER KEY SETS
TO CHANGE MODE
```

This screen informs the operator that to make changes, the Enter key or the Right key must be pushed, which will cause the display that can be changed to blink. Use the up or down key to change the display and the left or right key to move the blinking item on the display. After changes are made in the Set Up Menus pushing the enter Key, Button, will accept the changes made. With the Right Key Sets To Change Mode screen displayed, pushing the ENTER button will access the first main submenu under the Set Up main menu, which is the Chassis Values Set Up Menu.

Table 11.1: Chassis Values Main Set Up Menu Screen (BTD/BRD)

```
SET-UP MENUS OF  
CHASSIS VALUES
```

This is the System Set Up Chassis Values Main Sub Screen. Push the ENTER button to access the Chassis Values submenus or push the DOWN Arrow to view the next Set Up Main Sub Screen, which is the Set Up 8VSB Demodulator Main Sub Screen. **NOTE:** Refer to the description in Table 11B for how to change the values on the following set-up screens.

Table 11.1.1: Chassis Values Forward Power Set Up Screen (BTD/BRD)

```
FWD POWER 100%  
POWER SET ■■■■■■
```

This screen allows the user to increase or decrease the power output of the System.

Table 11.1.2: Chassis Values Model Number Set Up Screen (BTD/BRD)

```
MODEL NUMBER  
CU1000BTD
```

This screen allows the user to change the model number, if needed, due to changes to the old model. This will activate the proper screens which are displayed.

Table 11.1.3: Chassis Values Jump to Menu on Fault Set Up Screen (BTD/BRD)

```
JUMP TO MENU  
ON FAULT IS ON
```

This screen allows the user to select if the system will display, automatically when ON is selected, the screen indicating a faulted condition when it occurs.

Table 11.1.4: Chassis Values Latch On an Input Fault Set Up Screen (BTD/BRD)

```
LATCH AN INPUT  
FAULT IS SET ON
```

This screen allows the user to select that the system will latch the input fault if it occurs, then if the input returns the fault will still register, by selecting ON.

Table 11.1.5: Chassis Values IF Processor Selection Screen (BTD/BRD)

```
IF PROCESSOR IS  
REQUIRED YES
```

This screen allows the user to select that the system has an IF Processor.

Table 11.1.6: Chassis Values Downconverter Selection Screen (BTD/BRD)

```
DOWNCONVERTER IS  
REQUIRED YES
```

This screen allows the user to select that the system has a Downconverter.

Table 11.1.7: Chassis Values Amplifier Power Supply Voltage Screen (BTD/BRD)

```
AMP POWER SUPPLY  
VOLTAGE IS 30VDC
```

This screen allows the user to select that the Power Supply Voltage.

Table 11.1.8: Chassis Values number of Amplifiers in System Screen (BTD/BRD)

```
EXPECTING 0 AMPS  
ENT KEY TO SETUP
```

This screen indicates the current number of external amplifiers in the system.

Table 11.1.9: Chassis Values Reset Ethernet User Name Set Up Screen (BTD/BRD)

```
RESET ETHERNET  
USERNAME OFF
```

When applicable, this screen is used to reset the username/password file of the Ethernet controller. If this operation is selected, ON, the username/password file is erased thus allowing any user to login at administrator level.

Table 11.1.10: Chassis Values Reset Ethernet TCP Configuration Set Up Screen (BTD/BRD)

```
RESET ETHERNET  
TCP CONFIG OFF
```

When applicable, this screen is used to view or change the TCP/IP subnet mask of the Ethernet controller.

Table 11.2: 8VSB Demodulator Main Set Up Menu Screen (BTD/BRD)

```
SET-UP MENUS OF  
8VSB DEMODULATOR
```

This is the System Set Up 8VSB Demodulator Main Sub Screen. Push the ENTER button to access the Set Up 8VSB Demodulator submenus or push the DOWN Arrow to view the next Set Up Main Sub Screen, which is the Set Up 8VSB Modulator Main Sub Screen. **NOTE:** Refer to the description in Table 11B for how to change the values on the following set-up screens.

Table 11.2.1: 8VSB Demodulator Channels Set Up Menu Screen (BTD/BRD)

```
DEMODULATE CFG 1  
CABLE CHANNELS
```

This screen allows selection of the channel plan which can be changed to either Off Air or Cable.

Table 11.2.2: 8VSB Demodulator Channel Select Set Up Menu Screen (BTD/BRD)

```
8VSB DEMODULATOR  
USE CABLE CH02
```

This screen allows selection of the channel, for the channel plan selected in the previous screen.

Table 11.3: 8VSB Modulator Main Set Up Menu Screen (BTD/BRD)

```
SET-UP MENUS OF  
8VSB MODULATOR
```

This is the System Set Up 8VSB Modulator Main Sub Screen. Push the ENTER button to access the Set Up 8VSB Modulator submenus or push the DOWN Arrow to view the next Set Up Main Sub Screen, which is the Set Up Upconverter Main Sub Screen. **NOTE:** Refer to the description in Table 11B for how to change the values on the following set-up screens.

Table 11.3.1: 8VSB Modulator MPEG Selection Set Up Screen (BTD/BRD)

```
MPEG INPUT FROM  
INTERNAL SOURCE
```

This screen allows the user to select between an internal or external source in the 8 VSB modulator. During the installation of the system, an off air signal may not be available to the modulator, therefore the user can set the source to INTERNAL to generate an 8 VSB signal inside the tray that can be used for set up. Once the Receive Signal is available, the source must be set to EXTERNAL.

Table 11.3.2: 8VSB Modulator Linear Equalization Selection Screen (BTD/BRD)

```
LINEAR  
EQUALIZER OFF
```

This screen controls the operation of the linear equalizer. When set to ON, the modulator applies linear correction to the IF output. When set to OFF, no correction is applied to the IF.

Table 11.3.3: 8VSB Modulator Non Linear Equalization Selection Screen (BTD/BRD)

```
NONLINEAR  
EQUALIZER OFF
```

This screen controls the operation of the non linear equalizer. When set to ON, the modulator applies non linear correction to the IF output. When set to OFF, no correction is applied to the IF.

Table 11.4: Upconverter Main Set Up Menu Screen (BTD/BRD)

```
SET-UP MENUS OF  
UPCONVERTER
```

This is the System Set Up Upconverter Main Sub Screen. Push the ENTER button to access the Set Up Upconverter submenus. This is the final Set Up Main Sub Menu. Push the LEFT Arrow to go back the Main System Set Up Screen. **NOTE:** Refer to the description in Table 11B for how to change the values on the following set-up screens.

Table 11.4.1: Upconverter Channel Selection Screen (BTD/BRD)

```
UPCONVERTER SET  
TO CHANNEL CH15
```

The Upconverter, transmit, channel should not be changed, unless the system is being converted from one channel to another. **NOTES:** Channel changes should only be made while the system is in standby. Contact Axcera Field Service at 1-724-873-8100 before changing values on this menu.

Table 11.4.2: Upconverter IF Frequency Selection Screen (BTD/BRD)

```
UPCONVERTER  
IF FREQ 44MHZ
```

The transmit channel IF Frequency should not be changed, unless the system is being converted from one digital IF Frequency to another. The IF Frequency can be changed to 36 MHz or 44 MHz by pushing the Up or Down Arrow. The IF Frequency for all ATSC systems should be 44 MHz. **NOTES:** Changes should only be made while the system is in standby. Contact Axcera Field Service at 1-724-873-8100 before changing values on this menu.

Table 11.4.3: Upconverter LO Frequency Selection Screen (BTD/BRD)



UPCONVERTER LO
FREQ 1523.000MHZ

The transmit channel LO Frequency should not be changed, unless the system is being converted to a new frequency with an Offset. **NOTES:** Changes should only be made while the system is in standby. Contact Axcera Field Service at 1-724-873-8100 before changing values on this menu.

This is the final Set Up Sub Menu. Push the LEFT Arrow to go back the Main Upconverter Set Up Screen. Push the LEFT Arrow again to go back the Main System Set Up Screen. Push the left arrow again to go to the RF Power screen.

This page intentionally left blank.

System Description

The Innovator CXB Series Systems are of two different types. They are either Regenerative Translators, example: CU100BRD (1312187), or DTV Transmitters, example: CU100BTD (1312180). The Regenerative Translator (BRD) accepts an RF On Channel signal (-79 to -8 dBm) and converts it to a DTV RF On Channel output signal. The DTV System (BTD) takes a SMPTE-310 Input and converts it to a DTV RF On Channel output signal. The output power level of either configuration is at 10, 30, 50, 100 or 125 Watts ATSC using a single tray, at 250 or 500 Watts ATSC using an additional single amplifier tray, at 1000 Watts ATSC with two Amplifier trays, at 1500 Watts ATSC with three Amplifier trays, or at 1800 Watts ATSC with four Amplifier trays. The Innovator CXB Series system provides linear and nonlinear correction capability for the transmission path as well as internal test sources that are used during initial system installation.

The CU5-CU125 Innovator CXB Series systems and the CU50 driver tray for higher power systems contain the Digital Modulator w/Power Conditioner (1309629) that is made up of (A2) the Digital Modulator Board (1304883) and (A22) the Power Conditioner Board (1309404). The tray also contains (A3) the IF Precorrector Board (1308796), (A4) the Frequency Agile Upconverter (1309695), and (A6) the Amplifier Assembly. The (A7) Output Detector Board (1308685 or 1312207), (A8) the Innovator CX Control Board (1312543), (A9) the +5V, $\pm 12V$ Power Supply and (A10) the +24V/+28V/+32V/+39VDC Power Supply are also contained in the tray. The BRD kit (1310182) supplies the (A1) 8 VSB Demodulator Board (1308275) to the tray to make it a regenerative translator.

The type of (A6) Amplifier Assembly used changes as the output power of the system changes. The Amplifier Assembly (1309621) is used in CU5 systems, the Amplifier Assembly (1312566) is used in CU30 and CU50 systems and the Amplifier Assembly (1312191) is used in CU100 and CU125 systems.

The (A10) Power Supply Assembly also changes as the output power of the system changes. A +24V Power Supply is used in CU5 systems, a 28V 300W Power supply is used in CU30 Systems, a +36V/600W Power Supply operating at 30V is used in CU50 systems and a +42V/1100W Power Supply operating at 39V is used in CU100 and CU125 systems.

To operate as an ATSC Transmitter (BTD), the SMPTE-310 input at (J1) connects directly to the input jack (J42) on the (A2) Digital Modulator Board (1304883). To operate as a Regenerative Translator (BRD), the DTV ON Channel RF Input at (J1), (-8 to -79 dBm) connects to the Tuner Input Jack on (A1) the 8 VSB Modulator Board (1308275) supplied with the (BRD) kit. The 8 VSB Modulator Board (1308275) converts the DTV input to a SMPTE-310 output at (J13) that connects to the input jack (J42) on the (A2) Digital Modulator Board (1304883). The rest of the tray operates the same for both the BRD and the BTD system. The IF output of the 8 VSB modulator board connects to J2 on the IF pre-corrector board (1308796). The IF Pre-Corrector Board provides ALC, automatic or manual, gain control of the IF level. The board also supplies pre-correction Response, In Phase and Quadrature Non-Linear adjustments. The board has the circuitry for ALC Fault, Input Fault and Modulation Fault monitoring and indications. The IF is connected to the digital upconverter board (1309695) that takes the 44 MHz or 36 MHz IF signal and converts it to a TV channel frequency in the range of 54-860 MHz. The RF on channel signal is fed to the ALC Board, Innovator CXB Series (1308570), which is used to control the drive power to the RF amplifier chain in the CU5, CU30, CU50, CU100 and CU125 Transmitter/Translators. In a CU30 or CU50, the RF is

connected to the (A6) Amplifier Assembly (1312566) that is made up of (A6-A1) the 2 Stage UHF Amplifier Board, CU30 (1308784) and (A6-A2) the RF Module Pallet w/Philips transistors (1300116). The assembly has approximately 36 dB of gain. The amplified output at approximately +38 dBm connects to the (A7) Output Detector Board (1308685 or 1312207) which provides forward (2V=100%) and reflected (2V=25%) power samples to the CU Control Board (1312543) for metering and monitoring purposes. An output power sample is also supplied to the front panel sample jack J15, which is a 50 Ohm BNC type. The typical sample value in a CU50 is approximately 60dB down from the output power level of the tray. The RF output is cabled to J2 the "N" connector RF output jack on the rear panel of the tray. In CU5, CU30, CU50, CU100 and CU125 systems the output connects to a digital mask filter and then the antenna for your system. In CU250 and CU500 systems, the RF input, from the CU50 driver tray, is connected to J1 on the rear panel of the amplifier tray. The RF is cabled to J1 on the Amplifier Heatsink Assembly in the CU250 or CU500 amplifier tray. In CU1000 and higher power systems the RF is connected to a splitter and then to the inputs of the CU500 amplifier trays.

The CU250 ATSC system is made up of a CU50 Tray and a 250 Watt ATSC Amplifier Tray. The CU50 is used as a driver that connects to the 250 Watt Amplifier tray and supplies the needed drive level to produce the 250 Watts output of the system. The control and operating parameters of the 250 Watt Amplifier Tray are displayed on the LCD Screen on the CU50 Tray. In the CU250, the RF input signal at J1 on the amplifier heatsink assembly is fed to J3 on the LDMOS amplifier pallet. The amplified output of the pallet, which has approximately 15 dB gain, is connected to the coupler board before it is cabled to J2 the RF output jack of the Amplifier Heatsink Assembly. The coupler board supplies a forward and a reflected power sample to the amplifier control board for metering and monitoring purposes.

The CU500 ATSC system is made up of a CU50 Tray and a 500 Watt Amplifier Tray. The CU50 is used as a driver that connects to the CU500 Amplifier tray and supplies the needed drive level to produce the 500 Watts output of the system. The control and operating parameters of the 500 Watt Amplifier Tray are displayed on the LCD Screen on the CU50 Tray. In the CU500, the input RF signal at J1, located on the rear panel of the tray, is fed to J1 on the 4 Way Splitter Board, which supplies four outputs, one to each 878 amplifier pallet. Each amplifier pallet has approximately 14 dB gain. The amplified outputs of the pallets are combined in the 4 Way combiner board whose output is at J1. The RF is connected to J2 the 7/16" (1.1cm) Din RF output jack located on the rear panel of the tray. The 4 way combiner board supplies a forward and a reflected power sample to the amplifier control board for metering and monitoring purposes. In a CU500, the typical sample value at J6, a 50Ω BNC jack located on the front panel of the tray, is approximately 65dB down from the output power level of the tray.

In higher power systems, multiple amplifier trays are used along with splitters and combiners to produce the desired output. The CU1000 is made up of a CU50 driver tray, a two way splitter, two CU500 amplifier trays and a two way combiner. The CU1500 is made up of a CU50 driver tray, a three way splitter, three CU500 amplifier trays and a three way combiner. The CU1800 is made up of a CU50 driver tray, a four way splitter, four CU500 amplifier trays and a four way combiner.

The On Channel RF output of the amplifier tray either connects directly to the low pass filter and the digital mask filter then to the antenna in single amplifier systems or to a combiner, the low pass filter and a digital mask filter and finally to the antenna in multiple amplifier systems.

(Optional) Innovator CXB Series Web Ethernet Interface

The (Optional) Innovator CXB Series Web Ethernet Interface (1310183) allows for the monitoring and control of the Innovator CXB Series system without the need for special software on the remote computer. This option may not be included in your system.

The screenshot shows a web interface for configuring an Ethernet interface. At the top, there is a dark header bar with the Axcera logo on the left, 'GUI Version 1.5' and 'Back' and 'Manage Accounts' buttons in the middle, and 'SITE ID: XXXXXXXX' and 'the experts' logo on the right. Below the header, there are four input fields for configuration: 'IP Address: 192.168.000.001', 'Subnet Mask: 255.255.255.000', 'Gateway: 010.000.000.001', and 'Site ID: XXXXXXXX (Max length 7, see manual for special characters)'. A 'Save' button is located below the Site ID field.

Figure 7: Typical Ethernet Configuration Menu

For the first time configuration of the system, the following must be completed. A computer must be placed on the same LAN as the Innovator CXB Series system (**NOTE:** The Innovator CXB does not serve DHCP addresses – they must be entered manually on the setup computer), which has the following factory default settings. Refer to Figure 7 for a typical configuration screen. (**NOTE:** A crossover cable may be needed if connecting directly from a computer to the Innovator CXB Series system).

IP address: 192.168.0.1
Subnet Mask: 255.255.255.000
Default Gateway: 10.0.0.1

Once a connection has been established, the web interface can be launched by entering the IP address of the Innovator CXB Series system as a URL in the browser of the remote computer. A login screen will be displayed prompting for a user name and password, **which are case sensitive**. There are two levels of access: administrative and view only. The factory default user name and password is:

User name: admin
Password: axcera

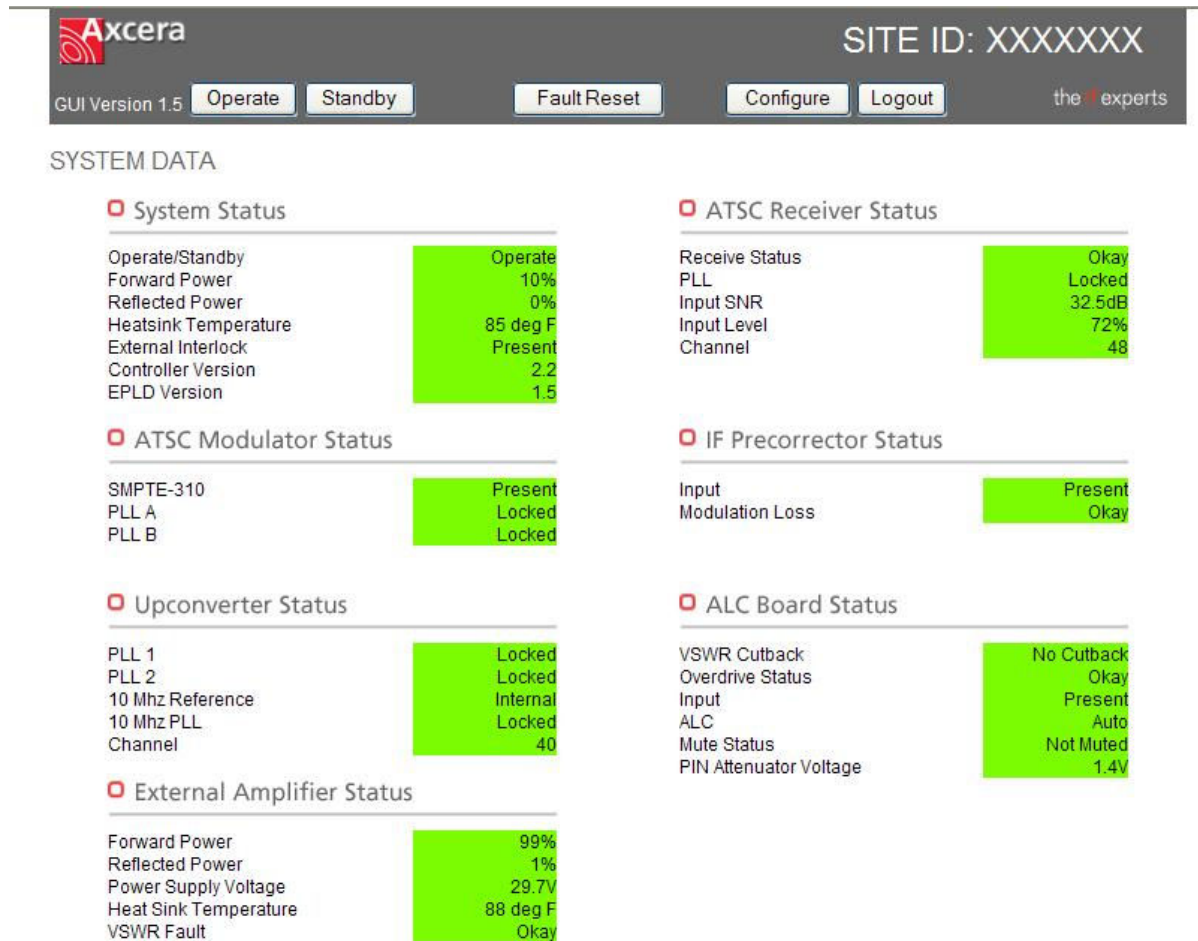

Figure 8: Typical Ethernet Main Control/Monitoring Screen

After logging in, the main control/monitoring screen is displayed, allowing operate and standby control and read back of the system parameters. Refer to Figure 8 for a typical main control/monitoring screen.

Green = okay/normal operation
 Yellow = warning, no fault
 Red = current fault
 Orange = latched fault

To change the web interface settings, click the **'configure'** button near the top of the screen while you are logged as an administrator. When entering a site ID be sure to not use any spaces or special characters except underscores, dashes, and forward slashes.

If the item on screen is Orange, which indicates latched fault, the fault can be reset by pushing the Fault Reset button located top middle of screen.

To manage user accounts, click the 'Account Management' button near the top of the configure screen

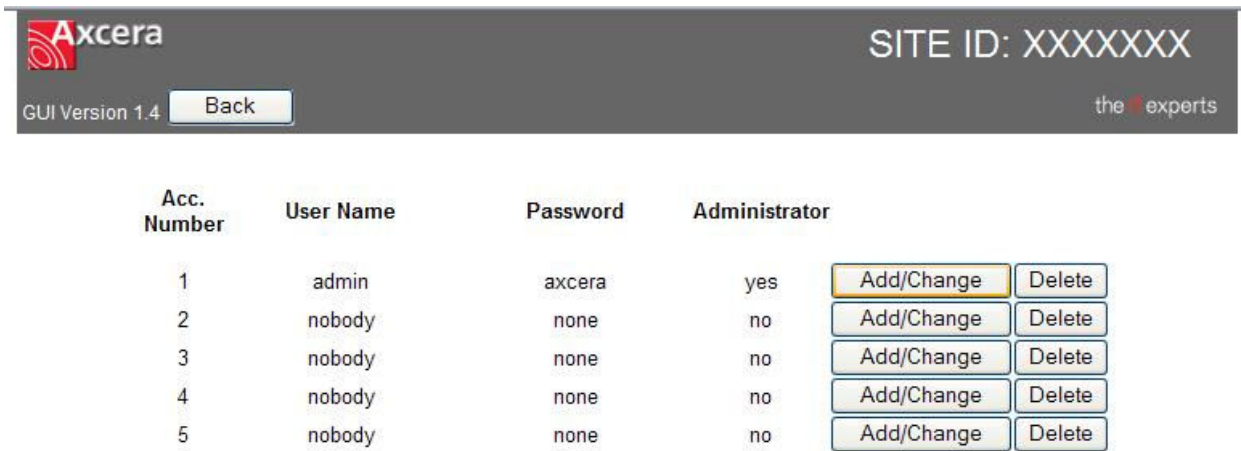

Figure 9: Typical Account Management Screen

The Innovator CXB supports up to 5 different users. To add or change one of the accounts click the Add/Change button in the row of the account you want to modify, then enter the desired name, password, and administrator rights for the user and click save.

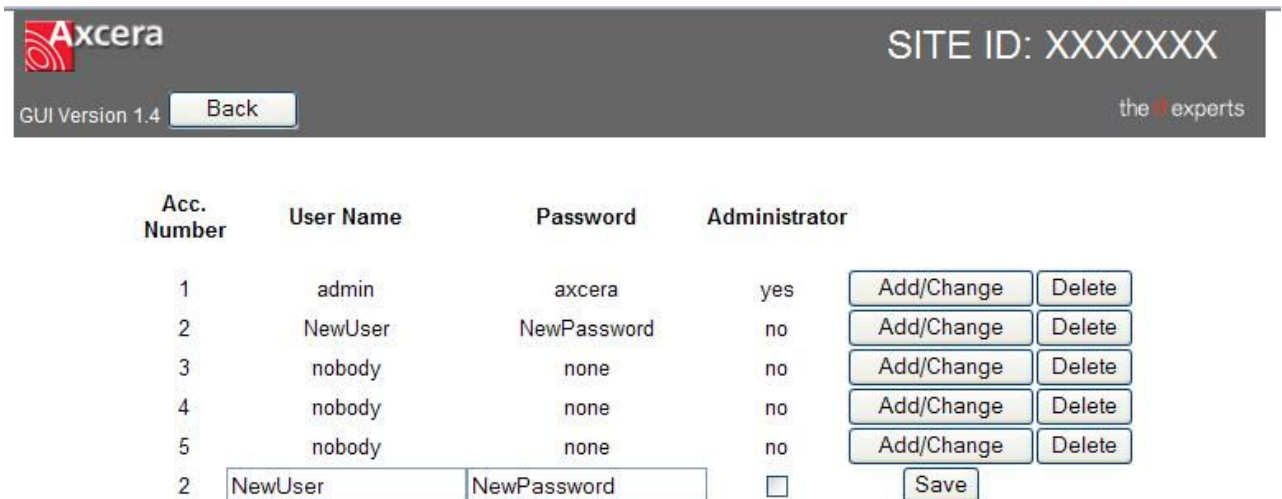

Figure 10: Typical Account Management Screen when Add/Change selected

When you have completed using the web interface, please remember to log out via the 'logout' button at the top of the screen.

NOTES: The Reset Ethernet User ID Screen, in the Set Up Menus on the LCD Display, allows the user the option of resetting the User name and Password for the Ethernet. The Yes or No selection can be changed by pushing the Up or Down Button. After the selection has been made, the user needs to depress the right or left arrow and then the display will ask "PUSH ENTER TO ACCEPT CHANGES". If the ENTER button is depressed, the change will be accepted. If any other button is depressed, the change will not be made. If Yes is selected on the screen, and accepted, the User name and Password will reset to the factory default.

The Reset Ethernet TCP Configuration Screen, in the Set Up Menus on the LCD Display allows the user the option of resetting the TCP Configuration for the Ethernet. The Yes or No selection can be changed by pushing the Up or Down Button. After the selection has been made, the user needs to depress the right or left arrow and then the display will ask "PUSH ENTER TO ACCEPT CHANGES". If the ENTER button is depressed, the change will be accepted. If any other button is depressed, the change will not be made. If Yes is selected on the screen, and accepted, the TCP Configuration will reset to the Default TCP Configuration.

Circuit Descriptions of Boards in the CU5, CU30, CU50, CU100 & CU125 Systems

(A1) 8 VSB Demodulator Board (1308275) - Only used with BRD operation

Overview

The 8 VSB demodulator assembly receives an off air 8 VSB signal on any VHF or UHF channel and demodulates this to an MPEG-2 transport stream that is per the SMPTE-310M standard. The input to the assembly is at an "F" style connector on the shielded tuner and can be at a level of -8 to -78 dBm. The tuner (TU1) down converts the RF channel to a 44 MHz IF signal. This signal is the input to the digital receiver chip U1. The digital receiver chip subsequently decodes the IF and delivers an MPEG-2 transport stream on a parallel data bus to a programmable logic array, U8. U8 clocks the asynchronous MPEG data from the receiver chip and outputs a synchronous data stream at a 19.39 MHz rate to buffer/driver U11. U11 subsequently drives the output at J13 to a lower level that is AC coupled out of the board.

Microcontroller Functions

A microcontroller, U17, is provided on this assembly to supervise the operation of the receiver chip and the tuner. In addition, the microcontroller also interfaces to the front panel LCD display via connector J24 and pushbutton interface on J27. On power up, the microcontroller sets the tuner to the last channel that was selected when the unit was powered down. In addition, the microcontroller also configures the digital receiver to operate as an 8 VSB receiver. The communication between all of the devices on this board is via an I2C serial bus that is local to this board.

Jumper and DIP Switch Settings

This board can be used in various assemblies. When this assembly is installed in the Innovator CXB product, the jumper on J26 should be placed between pins 2 and 3. There are two other jumpers in this assembly, on J7 and J8. Both of these jacks should have the jumper placed between pins 2 and 3 for normal operation.

The DIP switch on this board is reserved for future use and should remain set with all switches in the OFF position.

**(A2) Digital Modulator Board (1304883), Part of the Digital Modulator
w/Power Conditioner (1309629)**

SMPTE-310 Input

The digital modulator board accepts a SMPTE-310 input at the SMA connector J42 from the 8 VSB demodulator board in a BRD system or directly from the RF input jack on the rear of the tray in an BTD system. This input is applied to a high speed window comparator U21 that adjusts the level to a low voltage TTL signal to be used by the Altera FPGA, U3. The SMPTE-310 signal is input to the FPGA to recover the clock and the data. A portion of the clock and recovery circuit is performed by a high-speed comparator, U17, which functions as an external delay circuit.

Channel Coder

The FPGA subsequently uses the SMPTE-310 clock and data as the input to the channel coder contained inside the FPGA. The channel coder is a series of DSP blocks defined by the ATSC standard for 8 VSB data transmission. These blocks include the data randomizer, Reed Solomon Encoder, data interleaver, trellis coder, and sync inserter.

The channel coder portion inside the FPGA generates the 8 distinct levels in an 8 VSB system. These levels are subsequently input to a linear equalizer that provides for frequency response correction in the transmission path. The linear equalizer is a 67 tap FIR filter that is loaded with tap values from the microcontroller, U1, located on this board. The output of the linear equalizer is then input to two pulse shaping filters, an in phase (I) and a quadrature (Q) filter that are also located inside the FPGA. The pulse shaping filters are FIR filters that have fixed tap values that are preset inside the FPGA. The output of the pulse shaping filters is then applied to a Pre-Distortion Linearizer chip, U4, which can be used to correct for nonlinearities in the data transmission path. The output of the Pre-Distortion chip is gain scaled and output to a dual D/A converter, which output a baseband I and Q analog signal.

Analog Output Section

The baseband I and Q signals from the D/A converter are applied to differential analog filters that remove some of digital artifacts from the D/A conversion process. The output of the I channel filter is then mixed with the pilot frequency, 46.69 MHz, using mixer U30. The output of the Q filter is mixed with the pilot frequency that is phase shifted 90 degrees using mixer U34. The mixers are current driven devices so that when the outputs of U30 and U34 are connected together, they provide a combined output. This combined output is subsequently input to a final differential output filter which provides the final IF output at the SMA connector, J38. To maintain signal integrity, this IF output is connected to the SMA connector J39 with a small semi-rigid cable assembly. The final IF output then appears at J1-2B.

Pilot Frequency Generation

The 46.69 MHz pilot, which is used in the mixing process, is generated from a 46.69 MHz VCXO, U37 that is phase locked to a 10 MHz reference. The VCXO and the 10 MHz are divided down to a common frequency, which is then compared internal to the FPGA. The FPGA subsequently provides error signals to an analog phase locked implemented with op amp stages U45-A, B and C. The output of these compensation stages is used as the control voltage to the VCXO, U37. The phase locked output of U37 is applied to an analog filter to remove harmonics of the pilot and then input to the quadrature splitter Z1. The outputs of Z1 are used as the inputs to the mixers in the analog output section.

Voltage Requirements

The ± 12 VDC and +5VDC needed for operation of the board connect to J1 on the Power Conditioner Board which delays the +5VDC so that the ± 12 VDC to the 8 VSB Modulator Board is applied first. The voltage output of the power conditioner board is at J2 that is jumpered to J30 on the 8 VSB modulator board.

The ± 12 VDC connect to the 8 VSB modulator board at J30-1. The +12V SYS connects to J18A, B & C and to regulator circuits. The +12V SYS is filtered by L2, L3, C105 and C106

before it is applied to the rest of the board as +12VQ and +12VI. The -12 VDC SYS connects to J19A, B & C and to regulator circuit. The -12V SYS is filtered by L6, L7, C111 and C112 before it is applied to the rest of the board as -12VI and -12VQ.

The +12V SYS also connects through the resistor R81 to provide +5V EXT to the rest of the board, and to the regulators U23 that provides +3.3V to the rest of the board and to U27 that provides +1.8V output. The +3.3V also connects to U24 that supplies +1.5V output. The +12V SYS connects to the regulator U25 and U26 to supply the +5VA output. The output of U25 also connects to U28, which provides the +5V output to the rest of the board. +12V SYS is filtered by L4 and C107 to provide the +12V output to the board. The -12V SYS also connects to the regulator U22 that provides the -5V VA to the rest of the board. -12V SYS is filtered by L5 and C108 to provide the -12V output to the board.

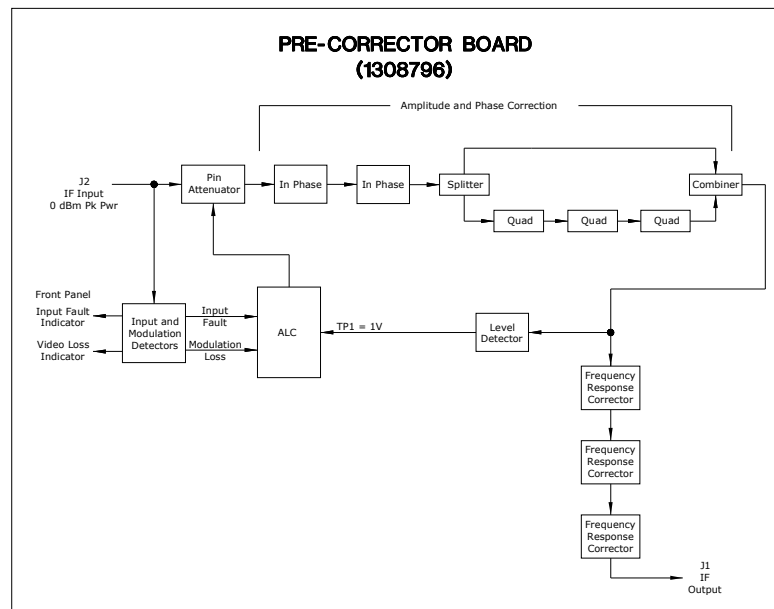

(A3) IF Pre-Corrector Board (1308796)

The IF Pre-Corrector Board provides ALC, automatic or manual, gain control of the IF level. The board also supplies pre-correction Response, In Phase and Quadrature Non-Linear adjustments. The board has the circuitry for ALC Fault, Input Fault and Modulation Fault monitoring and indications.

The input IF signal at J2, typically 0 dBm peak power centered at 36 or 44 MHz, is fed to a splitter circuit Z1 which produces two equal outputs, one at Port 1 and the other at Port 2. The output at Port 1 connects to the input and modulation fault circuitry. The output at Port 2 connects to the pin-diode attenuator circuit.

Pin-Diode Attenuator Circuit

The output of Z1 at Port 2 connects to a pin-diode attenuator circuit that consists of CR1, CR2 & CR3. Each of the pin diodes contains a wide intrinsic region; this makes the diodes function as voltage-variable resistors at this intermediate frequency. The value of the resistance is controlled by the DC bias supplied to the diode. The pin diodes are configured in a pi-type attenuator configuration where CR1 is the first shunt element, CR3 is the series element, and CR2 is the second shunt element. The control voltage, which can be measured at TP2, originates either from the ALC circuit when the switch S1 is in

the ALC Auto position, between pins 2 and 3, or from pot R37, MAN GAIN, when S1 is in the Manual Gain position, between pins 1 and 2. In the pin diode attenuator circuit, changing the amount of current through the diodes by forward biasing them changes the IF output level of the board. By controlling the value of the voltage applied to the pin diodes, the IF signal level is maintained at the set level.

When the IF signal passes out of the pin-diode attenuator through C7, it is applied to the modular amplifier U1. This device contains the biasing and impedance-matching circuits that makes it operate as a wide-band IF amplifier. The output of U1 connects through C8, NON-LIN IN, to the Summing Port input of the splitter Z3. The splitter provides the outputs to the Non-Linear Pre-Corrector stages. The output at Port 1 connects to the Quadrature Pre-Corrector and the output at Port 2 connects to the In Phase Pre-Correctors.

In Phase and Quadrature Corrector Circuits

Two of the Pre-Corrector stages are in the In Phase Amplitude pre-correction path and one stage is in the Quadrature Phase pre-correction path. Each stage has a variable threshold control adjustment, R67 and R69, in the In Phase path, and R89 in the Quadrature path, which determine the point that the gain is changed in each of the stages.

The output of Z3 at Port 2 connects to J10, which is jumpered through W5 to J9. External In-Phase Corrector circuits may be connected between these jacks. The signal from J9 connects to the first corrector stage on the board. The first corrector stage in the In Phase path operates as follows. The In Phase IF signal is applied to the transformer T3, which doubles the voltage swing by means of a 1:4 impedance transformation. Resistors R75 and R78 form an L-pad that lowers the level of the signal. The input signal level, when it reaches a set level, causes the diodes CR9 and CR11 to turn on, generating current flow that puts them in parallel with the L-pad. When the diodes are put in parallel with the resistors, the attenuation through the L-pad is lowered, causing stretch of the signal.

The signal is next applied to amplifier U8 to compensate for the loss through the L-pad. The breakpoint, or cut-in point, for the first corrector is set by controlling where CR9 and CR11 turn on. This is accomplished by adjusting the threshold cut-in resistor R67. R67 forms a voltage-divider network from +6.8 VDC to ground. The voltage at the wiper arm of R67 is buffered by the unity-gain amplifier U5A. This reference voltage is then applied to R68, R71, and C33 through L11 to the CR9 diode. C33 keeps the reference from sagging during the vertical interval. The .9 VDC reference voltage is applied to the unity-gain amplifier U5B. The reference voltage is then connected to diode CR11 through choke L12. The two chokes L11 and L12 form a high impedance for IF that serves to isolate the op-amp ICs from the IF.

After the signal is amplified by U8, it is applied to the second corrector stage in the In Phase path through T4. The second In Phase Stage and the stage in the Quadrature path operate in the same fashion as the first. All three corrector stages are independent and do not interact with each other. The In Phase Correctors can be disabled by moving the jumper W4 on J8 to the Disable position, between pins 1 & 2. This moves all of the breakpoints past the signal peaks so that they will have no affect. The pre-distorted IF signal, in the In Phase path, connects to the op amp U9 whose output level is controlled by R88, the in phase amplifier adjustment. The pre-distorted In Phase IF signal connects to Port 1 on the combiner Z4.

The Port 1 output of Z3 connects from J11 through the W6 jumper to J12. The IF is connected to T5, the 1:4 impedance transformer input to the Quadrature circuit. External Quadrature Corrector stages may be connected between jacks J11 and J12. The pre-distorted IF signal, in the Quadrature Phase path, connects to the op amp U11 whose output gain is set by R102, which provides a means of balancing the level of the Quad Phase pre-distorted IF signal that connects to Port 2 on the combiner Z4.

The Quadrature and In Phase pre-distorted IF signals are combined by Z4, amplified by U10 and connected through C57 to the S Port of the splitter Z2. Z2 provides two outputs of the combined Quadrature and In Phase pre-distorted IF signals.

Frequency Response Corrector Circuit

The output of Z2 at Port 2 connects to the first corrector stage of the three-stage frequency-response corrector circuit. The three stages are adjusted as needed to attain the best response across the bandwidth. The frequency-response corrector circuit operates as follows. Variable resistors R24, R25 and R26 are used to adjust the depth and gain of the notches and variable caps C14, C15 and C16 are used to adjust the frequency position of the notches. These are adjusted as needed to compensate for frequency response problems. The jumpers W1 on J4, W2 on J5 and W3 on J6 are moveable to set the frequency response of the circuits for 44 MHz, which is between pins 2 & 3 or between 1 & 2 for 36 MHz.

The Non-Linear and Frequency Response pre-corrected IF is connected to the op-amp U2. After amplification, the IF is split with one path connected through a divider network to J1 the IF output jack on the board, -12 dBm. The other path is fed through a divider network to J3 the IF Sample Jack, -18dBm.

ALC Circuit

The other non-linear pre-corrector output of Z2 at Port 1 connects to the input of the ALC circuit. The IF signal is applied to the transformer T1, which doubles the voltage swing by means of a 1:4 impedance transformation. It is connected to the ALC detector circuit, consisting of C11, CR4 and R21. The detected ALC level output is amplified by U3A and wired to U3B, pin 6, where it is summed with the power control setting of R40 the ALC Adjust pot.

The output of U3B connects through S1 pins 2 to 3, if it is in the ALC position, to the pin-diode attenuator circuit, CR1, CR2 & CR3. The high forward biases them more or less, that increases or decreases the IF level, therefore the output level. When the input signal level increases, the forward bias on the pin attenuator decreases, therefore the output power decreases, that maintains the output power as set by the customer.

The ALC voltage is set for 1.0 VDC at TP1 with a -12 dBm peak sync output as measured at J1 of the board. The ALC action starts with the ALC detector level monitored at TP1. The detector output at TP1 is nominally, 1.0 VDC, and is applied through resistor R33 to a summing point at op-amp U3B pin 6. The current available from the ALC detector is offset, or complemented, by current taken away from the summing junction. In normal operation, U3B pin 6, is at 0 VDC when the loop is satisfied. If the recovered or peak-detected IF signal level at the IF input to this board should drop, which normally indicates that the output power has decreased, the null condition no longer occurs at U3B pin 6. When the level drops, the output of U3B pin 7 goes more positive. If S1 is in the Automatic position, it will cause the ALC pin-diode attenuators CR1, CR2, and CR3 to have

less attenuation and therefore increase the IF level that will compensate for the decrease in the output power level.

If the ALC cannot increase the input level enough to satisfy the ALC loop, due to the lack of range, an ALC fault will occur. The fault is generated because U3C pin 9, increases above the trip point set by R47 and R50 until it conducts. This makes U3C pin 8, high and causes Q3 to conduct, which lights the Red ALC Fault LED DS1.

Input Fault and Modulation Fault Circuitry

The input IF signal at Z1 Port 1 connects to the input and modulation fault circuitry at T2. T2 doubles the voltage swing by means of a 1:4 impedance transformation. The output is connected to a detector circuit, consisting of R54, CR6, R58 and C19. The detected IF level output is amplified by U4A and then split. There is a Test Point at TP3 for a voltage reference check of the input level.

One output of U4A is connected to the detector CR5 that produces a Peak Sync Voltage, which is applied to the Op-Amp U12A. The detector provides a reference that determines the IF signal level at the input to the Board. The operation of the Threshold Detector is as follows. The Minimum IF Input level at TP3 is fed through detector CR5 to the Op-Amp IC U12A Pin 2. The reference voltage for the Op-Amp is determined by the voltage divider consisting of R52 and R57 off the +12 VDC line. When the detected input signal level at U12A Pin 2 falls below this reference threshold, approximately 10 dB below the normal input level, the output of U12A at Pin 1, goes to the +12 VDC Rail. This High is connected to the Gate of Q4 which forward biases it and creates a current path from the +12 VDC line through the Red LED DS2, the Input Level Fault Indicator which lights, and the Transistor Q4 to Ground. The High also connects through the diode CR7 to the Gate of Q6 that conducts and connects a low to J7-1, Input Loss, which is wired to the Control Board for control and monitoring.

The Video Input Level at TP3 is also fed to a modulation loss circuit consisting of the IC U4B, U12B and associated component. When the input signal level to the U4B falls below the reference set by R62 and R60, which acts as a loss of Modulation Detector, the output of U4B, goes high which is split. One part biases On the Transistor Q9. A current path is then established from the +12 VDC line, the resistors R63 and R64, the Red LED DS3, the Modulation Loss Indicator, which lights, through Q9 to ground. The other High output of U4B is connected to U12B pin 5 whose output at pin 7 goes High. This high connects to the gate of Q8 Biasing it On. With Q8 On, a low is connected to J7-2, Modulation Loss, which is wired to the Control Board for control and monitoring.

±12 VDC, +6.8 VDC, and VREF needed to operate the Board

The ±12 VDC connects to the board at jack J7. The +12 VDC connects to J7 pins 5 and 6 and is filtered by L10 and C25 before it is applied to the rest of the board. The -12 VDC connects to J7 pin 8 and is filtered by L9 and C23 before it is applied to the rest of the board.

Two reference voltages are needed for the operation of the pre-corrector circuits. One +12 VDC input is split by R103 and R104. The split +12 VDC output through R103 connects to the Zener diode VR1, which generates the +6.8 VDC output that is used in the pre-corrector stage. The split +12 VDC output through R104 connects to the diodes CR15 and CR16 that supply a .9 VDC reference output voltage, VREF, which provides

External 10 MHz reference is present. The Red LED DS3 will light if the PLL for the 10 MHz oscillator is not locked.

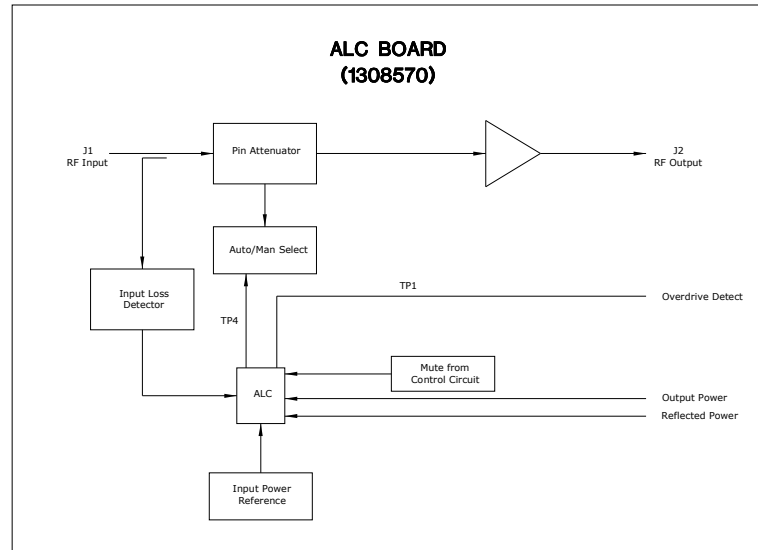

(A5) ALC Board, Innovator CX Series (1308570)

The ALC Board, Innovator CX Series, is used to control the RF drive power to the RF amplifier chain in the CU30, CU50, CU100 and CU125 systems. The board accepts an 8-VSB RF input signal at a nominal input level of -3 dBm average power and amplifies it to whatever drive level is necessary to drive the final RF amplifier in the tray to full power. The input signal to the board at J1 is split by U4, with one half of the signal driving a PIN diode attenuator, DS1 and DS2, and the other half driving a detector, U13, that is used to mute the PIN attenuator when there is no input signal. The output of the PIN attenuator is sent to two cascaded amplifiers, U2 and U3, which are capable of generating +10 dBm average power from the board at J2.

The PIN attenuator is driven by an ALC circuit or by a manual fixed voltage bias, depending on the position of switch S1. When the switch is pointing to the left, looking from the front of the tray, the ALC circuit is enabled. When the switch is pointing to the right, the ALC circuit is disabled and the PIN attenuator is controlled through the Manual gain pot R62. When the switch is in either ALC or manual, the voltage in the unused circuit is preset low by the circuitry connected to pins 4-6 on SW1. This allows the RF power to ramp up slowly to full power when the switch changes positions. CR8, C33 and associated components control the ramp up speed of the manual gain circuit. CR9, C42 and their associated circuits do the same thing for the ALC circuit. The practical effect of this is to preset the RF drive power to near zero output power when enabling and disabling the ALC, followed by a slow controlled ramp up of power.

The ALC circuit normally attempts to hold the tray output power constant, but there are four faults that can override this. These faults are Input Fault, VSWR Cutback Fault, VSWR Shutdown Fault and Overdrive Fault.

The Input Fault is generated by comparator U7C and presets the PIN attenuator and ALC circuit to maximum attenuation whenever the input signal drops below about -7 dBm. Test point TP2 allows the user to measure the detected input voltage.

The VSWR cutback circuit is set so that the ALC circuit will start reducing RF drive once the Reflected power reaches a level of about 6% and will keep reducing the drive to maintain that level. U8A, U8B and their associated components, diode-or the metering voltages, which generates this cutback. The forward power is scaled to $2V = 100\%$ and the reflected power is scaled to $2V = 25\%$. The Reflected metering voltage is doubled again by U8B so that when the voltage of U8B exceeds the voltage at the output of U8A, the reflected power takes over the ALC circuit. Once the U8B voltage drops below the forward power at U8A, the forward power takes over again.

The VSWR shutdown circuit will shut the tray down if the Reflected power increases to 15% or higher, which can happen if the tray sees reflected power when the ALC is in manual.

The Overdrive protection looks at a sample of the RF signal that is applied to J1 of the board. The peak level of this signal is detected and can be measured on TP1. This voltage is applied to a comparator with the threshold set by R38. If this threshold is exceeded, the ALC circuit mutes then ramps up to try again. This circuit also works in manual gain as well.

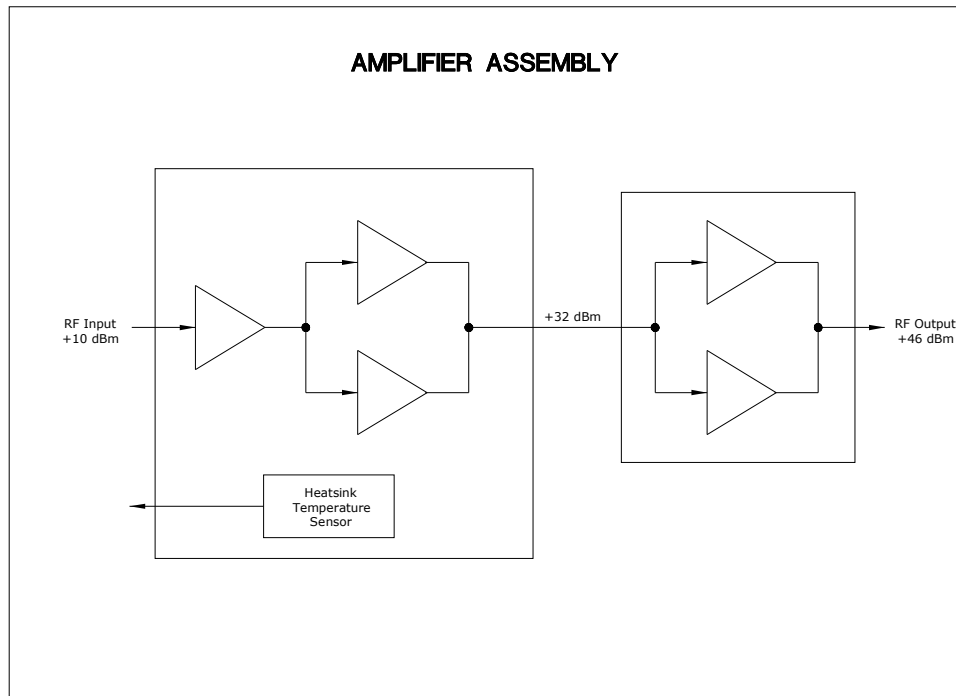

(A6) Amplifier Assembly (1309621) – Used in the CU5

The (A6) Amplifier Assembly (1309621) is made up of (A6-A1) the 2 Stage UHF Amplifier Board, 24V (1309608). The assembly has approximately 33 dB of gain.

(A6-A1) 2 Stage UHF Amplifier Board, 24V (1309608)

The 2 Stage UHF Amplifier Board, 24V (1309608) consists of a driver stage with a gain of +14dB and two parallel connected final amplifier stages each with a gain of +14dB. The working point settings for the 2 Stage Amplifier Board are factory set using the potentiometers R32 for Q2, R15 for Q1, and R24 for Q3 and should not be altered. The input RF connects to the first amplifier stage Q2. The output is split by U2 and

connected to the final amps. The final amplification circuit consists of parallel-connected push-pull LDMOS amplifier circuits Q1 and Q3 operating in class AB each with approximately 14 dB of gain. The board uses a power supply voltage of 24V. The RF transistors are operated at a voltage of 24V generated by the voltage regulators U6 and U7 for Q2, U5 and U3 for Q3 and U1 and U3 for Q1, which provide a separate regulated voltage to each transistor. In order to match the LDMOS impedance to the characteristic impedance of the input and output sides, matching networks are located before and after the amplifier circuits. The hybrid coupler U2 splits the input to the parallel amplifiers and the hybrid coupler U4 combines the amplified outputs. The combined output connects through a directional coupler to J1, the RF output jack of the board. The directional coupler provides an RF sample at J3 that is used by an external overdrive protection circuit located on (A5) the ALC Board. The RF output of the board is 6W maximum 8-VSB. At this power level the board draws approximately 3.6A total from the power supply.

(A6) Amplifier Assembly (1312566) – Used in the CU30 and CU50

The (A6) Amplifier Assembly (1312566) is made up of (A6-A1) the 2 Stage UHF Amplifier Board (1308784) and (A6-A2) the RF Module Pallet w/Philips transistors (1300116). The ALC Board (1308570) is also used with this assembly. The assembly has approximately 36 dB of gain.

(A6-A1) 2 Stage UHF Amplifier Board (1308784)

The 2 Stage UHF Amplifier Board, (1308784) consists of a driver stage and a parallel connected final amplifier stage which have a total gain of approximately 23 dB. The working point settings for the 2 Stage Amplifier Board are factory set using the potentiometers R32 for Q2, R15 for Q1, and R24 for Q3 and should not be altered. The input RF connects to the first amplifier stage U2, which has a gain of approximately 14 dB. The output is split by U2 and connected to the final amps. The final amplification circuit consists of parallel-connected push-pull LDMOS amplifier circuits Q1 and Q3 operating in class AB each with approximately 14 dB of gain. The board uses a power supply voltage of 28-32V. The RF transistors are operated at a voltage of 24V generated by the voltage regulators U1 for Q1, U5 for Q3 and U6 for Q2, which provide a separate regulated voltage to each transistor. In order to match the LDMOS impedance to the characteristic impedance of the input and output sides, matching networks are located before and after the amplifier circuits. The hybrid coupler U2 splits the input to the parallel amplifiers and the hybrid coupler U4 combines the amplified outputs. The combined output connects through a directional coupler to J1, the RF output jack of the board. The directional coupler provides an RF sample at J3 that is used by an external overdrive protection circuit located on (A5) the ALC Board. The RF output of the board is being used as a driver and has a level of 3W maximum 8-VSB. At this power level the board draws approximately 1.8A total from the power supply.

(A6-A2) RF Module Pallet w/Philips Transistors (1300116)

The RF Module Pallet, w/Philips Transistors, is made from the RF Module Pallet w/o Transistors (1152336). This broadband amplifier is for the frequency range of 470 to 860 MHz. The amplifier is capable of delivering a maximum output power of 100 Watts peak, with an amplification factor of approximately 13 dB.

The RF Module Pallet w/Philips Transistors (1300116) is a broadband amplifier for the frequency range of 470 to 860 MHz. The amplifier is capable of delivering a maximum

output power of 100 Watts peak, with an amplification factor of approximately 13 dB. The amplification circuit consists of push-pull amplifier blocks V1 and V2, connected in parallel, operating in class AB. In order to match the impedance of the transistors to the characteristic impedance of the input and output sides, matching networks are placed ahead and behind the amplifier blocks. Transformers Z3 and Z4 at the input to V1 and V2 and Z5 and Z6 at the output of V1 and V2 serve to balance the input and output signals. The paralleling circuit is achieved using the 3-dB input coupler Z1 and the second part of Z1, which is the 3-dB output coupler. The working point settings of the amplifier circuits are factory implemented by means of the potentiometers R9, R11, and R12 and should not be altered. The combined output of Z1 connects to the RF output jack of the board at J2. The output of the amplifier assembly at J2 connects to J1 on (A7) the output detector board.

(A6) Amplifier Assembly (1312191) – Used in the CU100 & CU125

The (A6) Amplifier Assembly (1312191) is made up of (A6-A1) the 1 Watt Amplifier Board (1310282), (A6-A2) the BL871 Single Stage Amplifier Board (1311041), and (A6-A3) the Dual 878 Pallet Assembly (1310138). The ALC Board (1308570) is also used with this assembly. The entire amplifier assembly has approximately 36 dB of gain.

(A6-A1) 1 Watt UHF Amplifier Module (1310282)

This board is a broadband UHF amplifier capable of producing an output power in excess of 1W Peak. It is normally operated at an average power of 100 mW 8VSB or lower. It consists of two AH202 MMICs operating in parallel. The board is powered by +12 VDC and has no adjustments. The board has a gain of approximately 16 dB.

(A6-A2) BL871 Single Stage Amplifier Board (1311041)

This board consists of a single stage amplifier operating at +42 VDC. The board has an overall gain of about 16 dB. The input to the board passes through a 3 dB attenuator consisting of R11-R13, and then is applied to the gain stage, which consists of a single LDMOS transistor Q1 operating in Class AB. The bias voltage for the transistor is generated through the voltage regulator U1, and is adjusted using pots R2 and R3. The Diode CR1 provides temperature compensation for the transistor. The transistor will output over 20 Watts DVB, but is typically used in a driver application at much lower output powers. The Directional Coupler U1 provides a 20 dB down sample of the RF output.

(A6-A3) Dual 878 Pallet Assembly (1310138)

This board is a UHF LDMOS power amplifier consisting of two power transistors operating in parallel. The board operates on a power supply voltage of +42 VDC. The voltage regulator U1 steps down the voltage to provide a bias voltage to each transistor. The diodes CR1 and CR3 are used to temperature compensate the bias voltage. As the RF transistors heat up, the diodes also heat up, causing the voltage across them to drop, lowering the bias voltage to the RF transistors so that it remains constant with device temperature.

The board has a gain of approximately 17 dB, and can operate at an output power of 150 Watts average power DVB, 220 Watts average power ATSC, or 440 Watts Peak Sync plus sound in analog operation. The transistors are operated in quadrature, with one

transistor operating 90 degrees out of phase of the other, which provides for a very good return loss across the UHF band on both the input and output of the board.

(A7) Output Detector Board (1308685 or 1312207 in the CU100BTD/BRD)

The (1308685 and 1312207) output detector boards are identical in operation except the (1312207) board can be used as either an average, for digital, or peak, for analog, detector board using jumpers on J5 and J6. The (A7) Output Detector Board provides forward (2V=100%) and reflected (2V=25%) power samples to the CU Control Board for metering and monitoring purposes. R7 is the reflected power calibration pot and R23 is the forward power calibration pot. A Forward power sample, -10 dBm, connects to J4 on the board, which is cabled to the front panel sample jack of the tray. The RF output of the board, typically +46 dBm, is at J2, which is cabled to J9 the RF Output Jack of the tray.

(A8) Control Card, Innovator CX (1312543)

The Innovator CX control board provides the overall system control for the CXB system. There are two main elements of the board, U7 and U9. U7 is a programmable logic device that is loaded with firmware, which provides the overall system control. It decides whether or not to allow the system to generate RF output power, and turns the +32 VDC power supply on and off depending on whether or not it is receiving any faults, either faults generated on board, or faults generated externally. The second major component of the board is the microcontroller U9, which controls the front panel indications and drives the display. The U9 microcontroller is not involved in the decision making process, U7 does that. Rather, it is layered on top of U7 and is the EPLD's interface to the outside world. Information is passed between the microcontroller and the EPLD. The microcontroller communicates information to and from the front panel and sends the EPLD the information it needs to decide whether or not to allow the system to turn on. The front panel viewable LEDs DS3 for Operate/Standby and DS4 for Status indicate the current operating condition of the system are mounted on and controlled by this board. The U9 microcontroller can also communicate, using the Optional Ethernet Kit, with a daughter card that allows the user to view remote control parameters via a web Ethernet interface.

The ± 12 VDC and +5 VDC from the (A9) power supply and the +32 VDC from the (A10) power supply are routed to the other boards in the tray through this board. The +32 VDC power supply operates all the time, and connects the +32 VDC to the board at J19-1, 2, & 3 with 5 common. Q13 on the control board is turned on and off to gate the +32 VDC, which connects through J19-6, 7 & 8, to the RF output stages.

The ± 12 VDC and +5 VDC input voltages to this board is connected through J21 and filtered before being connected to the rest of the board. +12 VDC connects through J21-1, +5VDC through J21-2 & 3, and -12 VDC through J21-6. Common connections for the input voltages are connected to J21-4 & 5. The ± 12 VDC and +5 VDC are used on this board and also routed to the other boards in the tray through this board. The +3.3 VDC for the microcontroller and programmable logic array, mounted on the board, is provided by the voltage regulator IC U6 from the filtered +5 VDC input. The output of U6 can be adjusted to +3.3 VDC using R120.

(A9 & A10) Power Supplies used in CU5, CU30, CU50, CU100 & CU125 and Driver for CU250 & higher power

Voltages for the operation of the boards in the tray are generated by (A9) a +5VDC and ± 12 VDC power supply and (A10) a +28VDC power supply for the CU30, a +30V supply for the CU50 and Driver for the CU250 and higher power, +39VDC for the CU100 & CU125, and +24VDC for the CU3. The 115VAC or 230VAC input to the CU3-CU50 tray connects through the AC power cord at J6, the power entry module located on the rear panel of the tray.

The CU100/125 tray only operates with 230VAC. An On/Off 10A/250VAC circuit breaker is part of the power entry module. With the circuit breaker switched On, the (L) line input is wired to F1 a 10 Amp fuse for over current protection. The AC lines are connected to terminal block TB1, which distributes the AC to (A9 and A10) the two DC power supplies. There are two varistors, mounted on TB1, connected from the line input to neutral and to ground for surge protection. The AC in the CU100/125 also connects to the (A11) fan mounted on the rear panel of the tray. The fan will run when AC is applied to the tray and the circuit breaker is switched On. The +5VDC and ± 12 VDC outputs of the (A9) power supply connects to the terminal block (TB2) that distributes the DC to the boards in the tray. Some of the +5VDC and ± 12 VDC outputs connect directly to the 8 VSB Demodulator and 8 VSB Modulator boards while the other outputs connect through the CU Control Board to the IF Precorrector, the Digital Upconverter, the ALC, the Amplifier Assembly and the Output Detector Boards.

The +24/+28/+30/+39VDC outputs of the (A10) power supply connect to the (A8) CU Control Board, which then supplies the switched +24/+28/+30/+39VDC to the (A6) Amplifier Assembly. In CU3-CU50 trays the DC output of the (A10) power supply also connects to the (A11) fan mounted on the rear panel, which will operate when AC is applied to the tray, the On/Off circuit breaker is On and the (A10) power supply is operating.

Circuit Description of External Board only used in CU250 and higher power Transmitters with external amplifier trays

(A5) System Metering Board (1312666)

The function of the System Metering Board is to detect forward and reflected output power samples and generate output voltages that are proportional to the power levels of the sampled signals for use by the control monitoring assembly in the exciter/driver tray.

There are two identical signal paths on the board: one for forward power and one for reflected power. A sample of the forward output power, from the external (A11) output coupler, enters the board at the SMA jack J3. The signal is filtered and connected to resistors R5, R3 and R6 that form an input impedance-matching network to Pin 3 on U1. The forward power signal is detected by the RF detector IC U1. The detected output at pin 7 is split with one half connected to the forward average calibration pot R7, digital, which adjusts the level of the signal connected to Pin 11 on U2. The other half of the split is connected to the peak calibration pot R18, analog, which adjusts the level of the signal connected to Pin 8 on U2. U2 is a Bilateral Switch IC whose output, digital or analog, is controlled by the selection of the modulation type in the exciter/driver tray. In this BTC transmitter the average, digital, output connects to the amplifier IC U3A that is wired to the SYS_FWD and RMT_FWD Power Metering Outputs. A reading of 2 VDC measured at

TP1 is equal to a 100% Forward Power reading on the meter. The SYS_FWD level connects to J9 on the board that is cabled to J11 on the exciter/driver tray for use in the control monitoring assembly. The RMT_FWD level connects to J10 on the board for use by remote control and monitoring.

A sample of the reflected output power, from the external (A11) output coupler, enters the board at the SMA jack J8. The signal is filtered and connected to resistors R26, R22 and R27 that form an input impedance-matching network to Pin 3 on U6. The reflected power signal is detected by the RF detector IC U6. The detected output at pin 7 is connected to the reflected calibration pot R25, which adjusts the level of the signal connected to the amplifier IC U3B that is wired to the SYS_RFLD and RMT_RFLD Power Metering Outputs. A reading of 2 VDC measured at TP2 is equal to a 25% Reflected Power reading on the meter. The SYS_RFLD level connects to J9 on the board that is cabled to J11 on the exciter/driver tray for use in the control monitoring assembly. The RMT_RFLD level connects to J10 on the board for use by remote control and monitoring.

+12 VDC enters the board at J9-1, from the exciter/driver tray and is connected through a filter and isolation circuit consisting of C31, C14 and L5 before it is connected to the regulator IC U5. U5 supplies the +5 VDC needed for operation of the ICs on the board. The +5 VDC is connected through a filter circuit consisting of C15, C19 and C21 before it is connected to the rest of the board.

Circuit Descriptions of Boards in the CU250, 250 Watt and CU500, 500 Watt ATSC Amplifier Trays

(A7) Amplifier Control Board (1312260)

The Amplifier Control Board uses a Programmable logic device to control the amplifier tray. It takes an enable signal from an external driver tray, and turns the power supplies on whenever the driver has told it to turn on, unless it detects faults internal to the tray. The board monitors the forward and reflected power, the heatsink temperature, the pallet currents, and the power supply voltage and will generate alarm signals if any of those parameters exceed safe limits. The amplifier tray has no front panel display other than a two LEDs, one for Status and one for Enable. The board sends all its output information, including the forward and reflected levels, back to the driver tray, through J4, so the information can be displayed on that tray's LCD Display. The board will generate a Red Blinking Status LED if it detects an alarm, fault, prompting the operator to look at the LCD display on the driver tray to see what fault has occurred.

The +5 VDC inputs to this board are routed through J4 and J5. The +5 VDC inputs are diode Or connected so that either the +5VDC from the (A8) power supply or the +5VDC from the (A9) power supply will operate the board. The +5VDC is split with one output connected to U1 a voltage regulator IC, which provides +5V and +5V_ANALOG as outputs. The +5 VDC is filtered before being connected to the rest of the board. The other +5 VDC output is connected to the regulator IC U2 that supplies +3.3 V to the microcontroller and programmable logic array.

(A10) Current Metering Board (1309130)

The current metering board measures the current into the RF output amplifier pallets and supplies this value to the control board. In the CU500 amplifier tray, there are four sensing circuits which are used. Each circuit has two parallel .01 Ω series current

sensing resistors and a differential input IC that supplies a voltage output that is proportional to the current for metering purposes. The +42VDC from the (A8) power supply connects to TB2 and TB4 on the board. The +42VDC from the (A9) power supply connects to TB8 and TB10 on the board. The +42VDC input at the TB2 input senses the current to the (A1) 878 output amplifier pallet through TB1 on the board. The +42VDC input at the TB4 input senses the current to the (A2) 878 output amplifier pallet through TB3 on the board. The +42VDC input at the TB8 input senses the current to the (A3) 878 output amplifier pallet through TB7 on the board. The +42VDC input at the TB10 input senses the current to the (A4) 878 output amplifier pallet through TB9 on the board.

The four sensing circuits are identical only one will be described. For the (A1) 878 amplifier pallet, the +42VDC from the (A8) switching power supply connects to TB2. R1 and R2 are the parallel .01 Ω current sensing resistors which supplies the voltage values to the U1 current sense amplifier IC. R11 is a gain adjust, which is adjusted to eliminate any rSense Error and to place the OpAmp output at 2.61V for 40Amps sense as measured at TP3. The current sense output at J1-1 connects to the (A7) control board for metering purposes.

(A5) 4 Way Splitter Board (1308933)

The 4 way splitter board takes the RF Input at J1 (\approx 11Watts ATSC) on the board and splits it into four equal outputs (\approx 4.75Watts ATSC) that connect to the inputs of the four 878 amplifier pallets at J1.

(A1-A4) 878 Amplifier Pallets (1310138)

There are four 878 Amplifier Pallets mounted on the 500 Watt Amplifier Heatsink Assembly. Each of the 878 pallets has approximately +16dB of gain for the UHF frequency range of 470 to 860 MHz. The pallets operate Class AB and generate 150 Watts ATSC with an input of 4.75 Watts ATSC.

(A6) 4 Way Combiner Board (1312368)

The 4 way combiner board takes the four RF Inputs at J4, J5, J6 & J7 (\approx 150Watts ATSC) on the board and combines them to a single output (\approx 500Watts) at J1 that connects to J2 the 7/16" (1.1cm) Din RF output jack of the tray.

(A8 & A9) 250 Watt and 500 Watt Amplifier Tray Power Supplies

The 230VAC, needed to operate the tray, connects through the AC power cord at J3, the power entry module located on the rear panel of the tray. In the 500W amplifier tray, there are two On/Off 20A/250VAC circuit breakers that are mounted on the back panel of the tray on either side of J3 the AC input jack. The AC lines are connected to a terminal block TB1. With the circuit breakers switched On, the AC is distributed to the two (A8 and A9) DC power supplies. TB1 has three varistors (VR1-VR3) connected across the AC input lines for surge and over voltage protection. The AC input from TB1 also connects to through 2 amp fuses to the two fans (A11 & A12) mounted in the tray. Both fans will run immediately when AC is applied to the tray.

The +5VDC for the operation of the amplifier control board in the tray is generated by the (A8 & A9) power supplies at J1-9 on each power supply. The +5VDC from the (A8) power supply connects to J4-8 and the +5VDC from the (A9) power supply connects to

J5-8 on the control board. The +5VDC is produced when AC is connected to the tray and the CB1 and/or the CB2 circuit breakers are turned On. Either or both power supplies provides the +5VDC for use by the control board.

The +42VDC needed by the amplifier modules on the heatsink assembly is generated by the (A8 & A9) power supplies. The power supplies will operate when AC is connected to the tray, the CB1 circuit breaker for the (A8) power supply and the CB2 circuit breaker for the (A9) power supply, are turned On and a Low is provided on the Inhibit Line that connects to J1-6 on the power supplies from the control board. The CB1 circuit breaker supplies the AC to the (A8) power supply which provides the +42VDC to the (A1) and (A2) 878 amplifier pallets. The CB2 circuit breaker supplies the AC to the (A9) power supply which provides the +42VDC to the (A3) and (A4) 878 amplifier pallets.

(Optional) ASI to S310 Converter Module

NOTE: Used only with STL ASI feed inputs.

The ASI to SMPTE310M converter takes the STL ASI feed input, if present in your system, and converts it to a SMPTE310M output which connects to the input to the Axcera system. The converter contains an ASI Motherboard (1311179), an ASI to 310 Conversion Board, Non-SFN (1311219), and a 120 VAC to +12 VDC converter module.

ASI Motherboard (1311179)

The ASI motherboard takes the +12 VDC, from the 120 VAC to 12 VDC converter module, and converts it to +5 VDC and +3.3 VDC which are used by the ASI to S310 conversion board.

U1 is a regulator IC that supplies an output of +5 VDC at J2-7 that connects to the ASI to 310 converter board. U2 is a regulator IC that supplies an output of +3.3 VDC at J2-11 that connects to the ASI to 310 converter board. Also +12 VDC is wired to J2-3 that connects to the ASI to 310 converter board.

The ASI motherboard is the mounting platform for the four LEDs that are displayed on the front of the module. The LEDs will be Green if everything is OK or Red if the indicated function is malfunctioning. The LEDs are Power, which indicates +12 VDC is connected to the converter, FIFO ERROR, which indicates an overflow or underflow condition in the input buffer, S310 Lock, which indicates the converted S310 signal is in a locked condition, and ASI Lock, which indicates the recovered ASI signal is in a locked condition.

ASI to 310 Conversion Board, Non-SFN (1311219)

The ASI signal is input to the ASI to S310 conversion board via J1. U2 de-serializes the ASI input signal into a parallel byte stream. The parallel byte stream is clocked into U6 which buffers and converts it to a valid S310 bi-phase encoded signal. Null packets are added or dropped during this process to obtain the valid 19.393 Mb/s output. U6 is also responsible for re-stamping the PCR clock. The final S310 output of the board is at J5.

System Set Up Procedure

This system was aligned at the factory and should not require additional adjustments to achieve normal operation.

This Innovator CX Series system is of a tray design with multiple boards inside the tray. If a board fails, that board needs to be changed out with a replacement board. The failed board can then be sent back to Axcera for repair. **NOTE:** Contact Axcera Customer Service Department at 1-724-873-8100 or fax to 1-724-873-8105, before sending in any board or module.

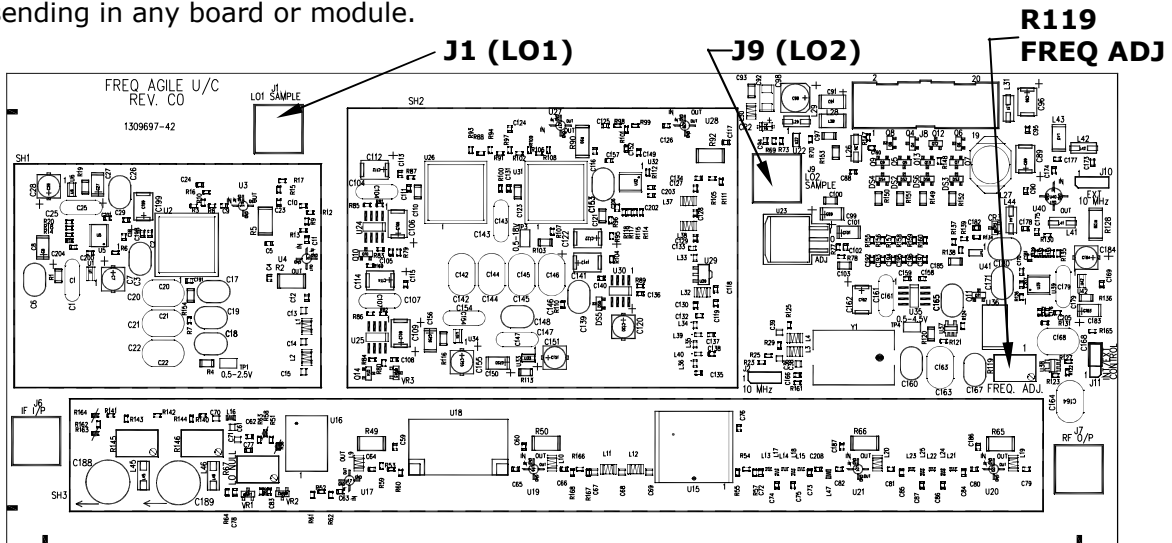

Figure 11: (A4) Digital Upconverter Board (1309695)

Set Up of the LO1 and LO2 Samples on Upconverter Board

The following procedure should only be attempted if the Internal 10 MHz Reference is used and the output carrier frequency is off. On the (A4) Digital Upconverter Board (1309695), there are two Sample Jacks, J1 for LO1, 1GHz sample, and J9 for LO2, the variable LO sample. Monitor the LO1 sample with a frequency counter and adjust R119 to 1 GHz. The output carrier frequency should now be correct.

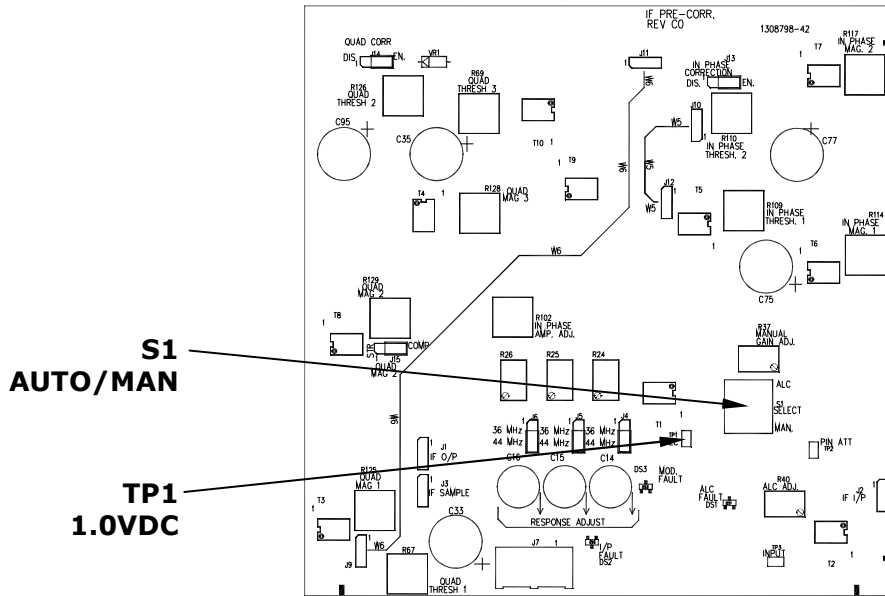

Figure 12: (A3) IF Pre-Corrector Board (1308796)

Set Up of the IF Precorrector Board in the System

Refer to Figure 12. Check that the Auto/Man switch S1 on the IF Pre-Corrector Board is in the Automatic ALC position. This is the normal operating position for the switch. The voltage at TP1 on the IF Pre-Corrector Board should be 1.0 VDC with 100% output power.

Refer to Figure 13. Check that the Auto/Man switch S1 on the ALC Board is in the Automatic ALC position. (**NOTE:** The silkscreen is incorrect on Rev. A, B & C boards. Auto position is with the bat to the left, toward J4.) Adjust R75 the ALC pot on the ALC Board as needed to attain 100% output power. Switch to Manual Gain (Manual ALC) and adjust the Manual Gain pot R62 for 100% output power. Switch the ALC Board back to Automatic ALC.

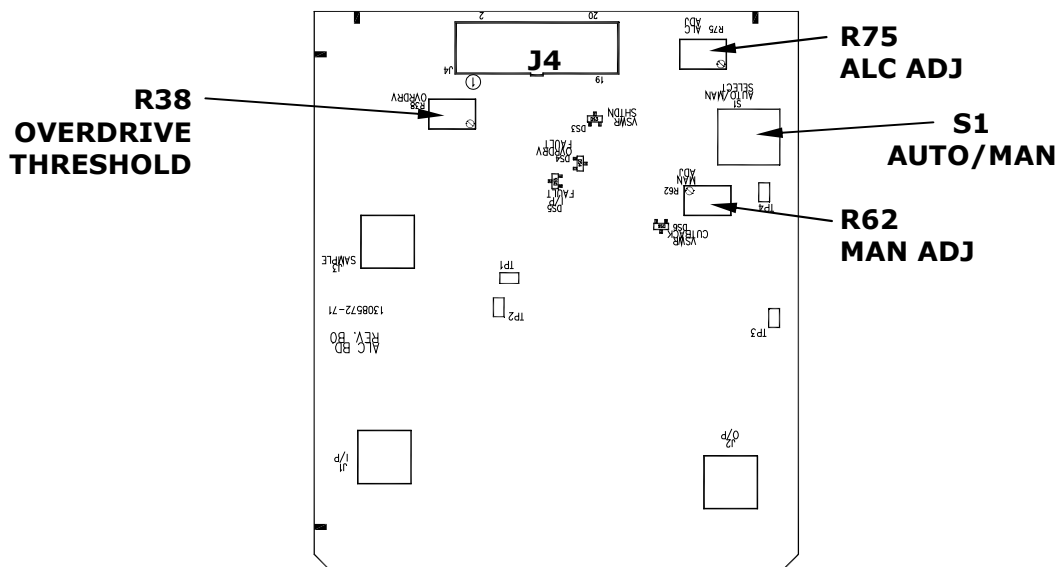

Figure 13: (A5) ALC Board (1308570)

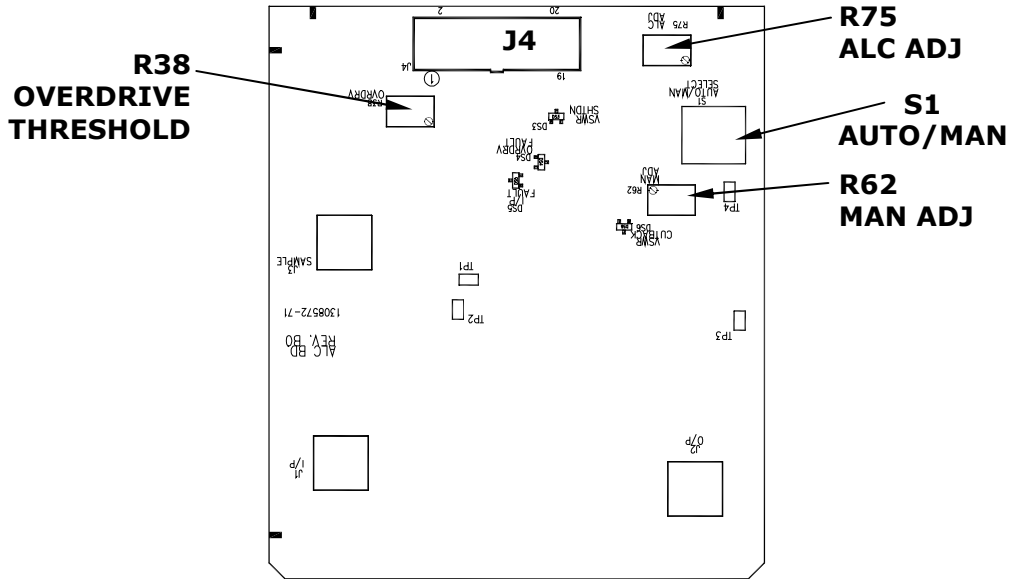

Figure 13A: (A5) ALC Board (1308570)

ALC Board Set-Up, Forward and Reflected Power Calibration for CU5, CU30, CU50, CU100 and CU125 Systems

NOTE: If your system is a CU250 or higher power, refer to the next section for the forward and reflected power calibration procedures.

Refer to Figure 13A. Locate (A5) the ALC Board (1308570), in the preset the Overdrive Threshold pot R38 full CW and set R62, Manual Adjust, and R75, ALC Adjust, full CCW.

Switch S1 to Manual Gain, and increase the output power to 100% using R62. Calibrate the system output power for 100% using R23, the Forward Calibration pot, on the Output Detector Board. Refer to Figure 14.

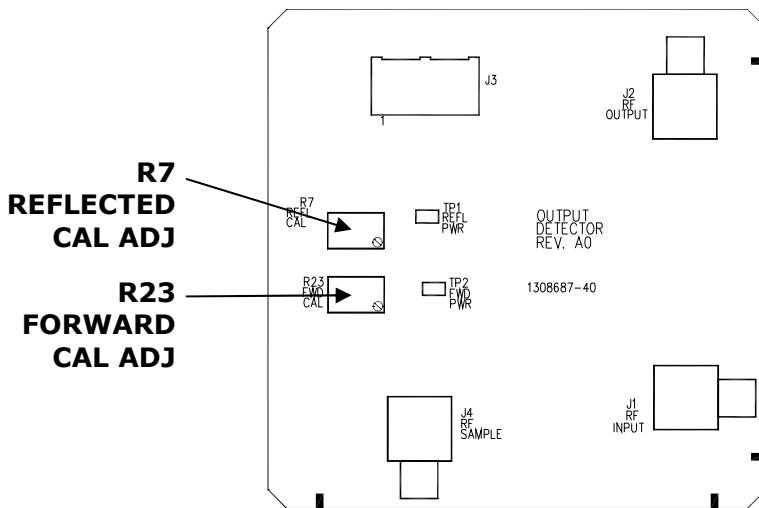

Figure 14: (A7) Output Detector Board (1308685)

Refer to Figure 13A. Turn the output power down to 10% power with R62 on the ALC Board. Remove the output RF connector from J2 on tray and calibrate the reflected power to 10%, using R7, the Reflected Calibration pot, on the Output Detector Board. Refer to Figure 14. Re-connect the RF output connector to the tray and increase the power, in Manual gain using R62 on the ALC Board, to 115%. Adjust the Overdrive pot R38 on the ALC Board, CCW until the overdrive threshold just trips and the Overdrive Fault LED DS4 lights. Turn R38 slightly CW so that power comes back up and DS4 goes out.

Switch S1 on the ALC Board to ALC. Turn the ALC Adjust pot R75 on the ALC Board until the power is 100%. Switch S1 between ALC and Manual to verify smooth switching, with minimal change in power. If necessary repeat the above procedure.

With the tray in ALC, use the ALC Adjust pot, R75, to decrease the power to 10%. Remove the RF output connector from the tray. Verify that the VSWR Cutback LED, DS6, comes on and the Reflected Power drops to approximately 6%. Reconnect the RF output connector and increase the power back up to 100% using R75.

This completes the set up of the ALC board and the Forward and Reflected Power Calibration.

Forward and Reflected Power Calibration of CU250 and Higher Power Systems

NOTE: If your system is a CU5, CU30, CU50, CU100 or CU125, refer to the previous section for the forward and reflected power calibration procedures.

Connect a calibrated coupler and average reading power meter to the output of the DTV mask filter. On the ALC Board (1308570), mounted in the Driver Tray, set the Switch S1, Auto/Manual ALC, to the Manual position. Refer to Figure 13A. Adjust the Manual adjustment Pot, R62, for the desired output power level as indicated on the average reading power meter. In the Amplifier Tray, on the Amplifier Control Board (1309822), refer to Figure 15; adjust the Forward Calibration Adjustment pot, R8, for a reading of 100% on the External Amplifier Forward Power screen of the LCD display mounted on the Driver Tray.

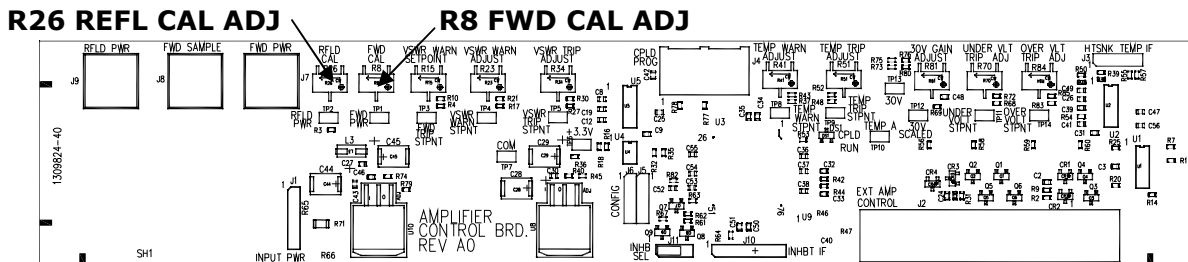

Figure 15: (A5) Amplifier Control Board (1309822)

On the ALC Board (1308570), mounted in the Driver Tray, set the Switch S1, Auto/Manual ALC, to the Auto position. Adjust the ALC adjustment Pot, R75, for a reading of 100% on the External Amplifier Forward Power screen of the LCD display mounted on the Driver Tray. This completes the forward power set up and calibration adjustments.

On the ALC Board (1308570), mounted in the Driver Tray, adjust the ALC adjustment Pot, R75, for a reading of 10% on the External Amplifier Forward Power

screen of the LCD display mounted on the Driver Tray. Disconnect the load or the antenna connected to the system. In the Amplifier Tray, on the Amplifier Control Board (1309822), adjust the Reflected Calibration Adjustment pot, R26, for a reading of 10% on the External Amplifier Reflected Forward Power screen of the LCD display mounted on the Driver Tray. Reconnect the load or the antenna to the system. Adjust the ALC adjustment Pot, R75, for a reading of 100% on the External Amplifier Forward Power screen of the LCD display mounted on the Driver Tray. This completes the reflected power calibration adjustment.

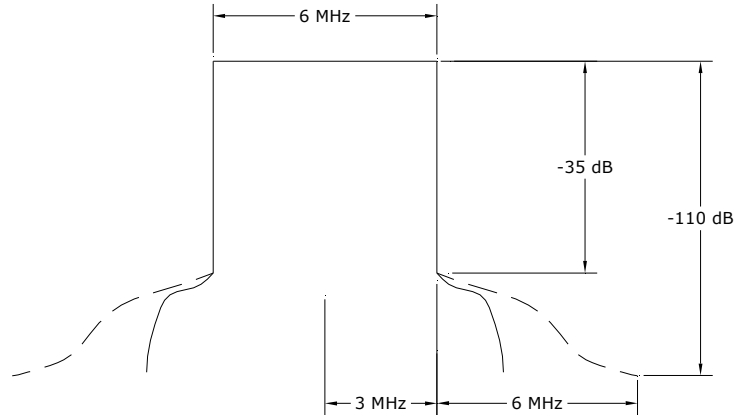

Figure 16: Typical 6 MHz Digital Spectrum

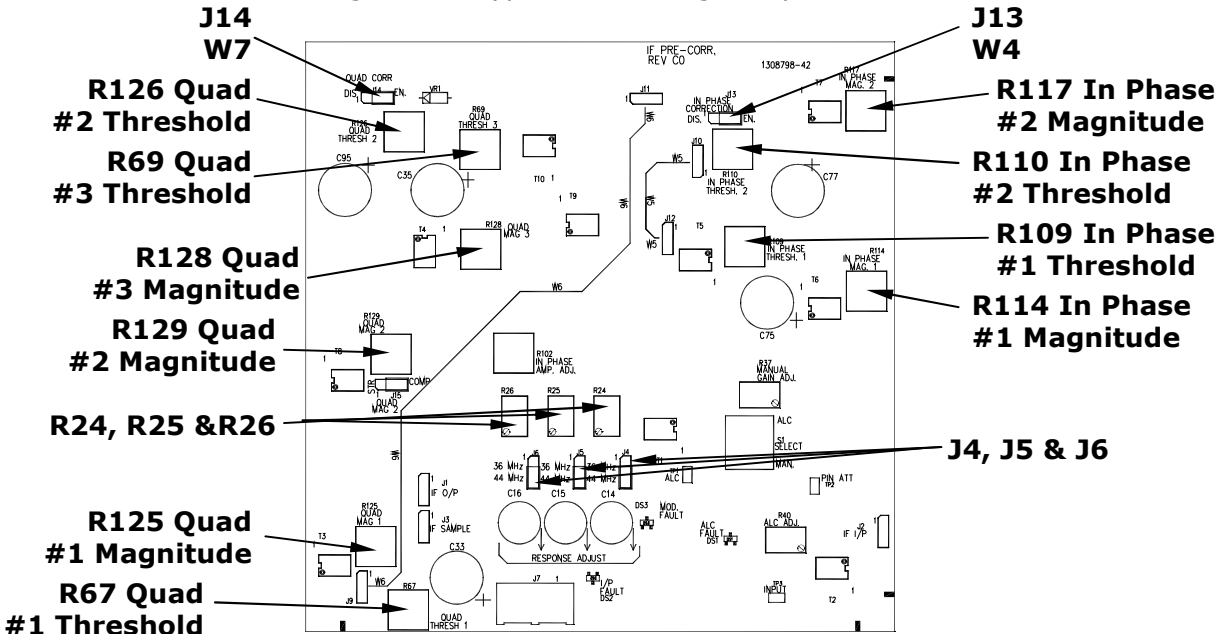

Figure 17: (A3) IF Pre-Corrector Board (1308796)

Linearity Correction Adjustment (Non-Linear Distortions)

As shipped, the system was preset to include amplitude and phase pre-distortion. The pre-distortion was adjusted to approximately compensate the corresponding non-linear distortions of the Power Amplifier.

NOTE: Refer to Figure 17. On (A3) the IF Pre-Corrector Board (1308796), check that the Quadrature Correction enable/disable jumper W7 on J14 and the In Phase

Correction enable/disable jumper W4 on J13 are in the Enable position, between pins 2 & 3.

Set up a spectrum analyzer with 30 kHz resolution bandwidth and 30 kHz video bandwidth to monitor the intermodulation products of the RF output signal of the Tray at J2. A typical 6 MHz digital spectrum is shown in Figure 16.

There are five Corrector stages, two in phase and three quadrature, with adjustments located on the IF Pre-Corrector Board. Each stage consists of a threshold and a magnitude stage. The adjustments are adjusted as needed to correct for any amplitude or phase intermod problems. R109 and R110 are the in phase threshold adjustments. R114 and R117 are the corresponding magnitudes. The threshold adjustments control the point in the signal's amplitude where the correction increases the gain, and the magnitude controls how much the gain is increased for each correction stage.

The quadrature adjustments provide predistortion for fixing Amplitude and Phase Modulation distortion in the amplifiers. R67, R126 and R69 are the threshold adjustments, and R125, R129 and R128 are the corresponding magnitudes.

The above pots are adjusted for the greatest separation between the digital signal and the intermod at the channel edges.

There is also a frequency response correction network on the board consisting of R24-R26 and C14-C16. This has been factory set. Any adjustment of these controls will result in having to reload taps into the digital modulator (See the Linearity Correction Adjustment (Linear Distortions) section below).

Linearity Correction Adjustment (Linear Distortions)

As shipped, the digital linear precorrector is preset in the factory for optimal system performance of the system and output filter. This precorrection should not require readjustment in the field.

However, in the event that field adjustment of the digital linear precorrection is required, Axcera does offer an optional Precorrector Tap Converter (PTC) application. This application allows the frequency response and group delay precorrection to be adjusted using one of the following pieces of test equipment:

- Rohde & Schwarz EFA-53 Demodulator with the FIR Coefficient Readout option
- Tektronix VSA-5000 Vector Signal Analyzer

The PTC application allows tap settings to be downloaded from the test equipment to a PC and then loaded into the Innovator CX through the serial interface. The instructions included with the PTC application software provide the detailed setup procedure.

If a problem occurred during the set up, help can be found by calling Axcera field support at 1-724-873-8100.

APPENDIX A

Innovator,
CU5-1800BTD/BRD,
ATSC Transmitter/
Regenerative Translator
Drawings

Innovator CXB Series System Drawing List

Innovator CXB Series Regenerative Translator/Transmitter Systems

CU5/30/50/100/125BRD Translator/BTD Transmitter Interconnect..... 1310876

CU5BRD Innovator 10 Watt Regenerative Translator

CU5BRD/BTD Block Diagram.....

CU5BRD/BTD Interconnect

CU5BTD Innovator 10 Watt Transmitter

CU5BRD/BTD Block Diagram.....

CU5BRD/BTD Interconnect

CU30BRD Innovator 30 Watt Regenerative Translator

CU30BRD/BTD Block Diagram

CU30BRD/BTD Interconnect..... 1312806

CU30BTD Innovator 30 Watt Transmitter

CU30BRD/BTD Block Diagram

CU30BRD/BTD Interconnect..... 1312806

CU50BRD Innovator 50 Watt Regenerative Translator (Also used as a driver)

CU50BRD/BTD Block Diagram

CU50BRD/BTD Interconnect..... 1312222

CU50BRD Assembly Drawing..... 1312225

CU50BTD Innovator 50 Watt Transmitter (Also used as a driver)

CU50BRD/BTD Block Diagram

CU50BRD/BTD Interconnect..... 1312222

CU100/125BRD Innovator 100/125 Watt Regenerative Translator

CU100BRD/BTD Block Diagram

CU100BRD/BTD Interconnect..... 1312177

CU100/125BTD Innovator 100/125 Watt Transmitter

CU100BRD/BTD Block Diagram

CU100BRD/BTD Interconnect..... 1312177

Innovator CU100/125BTD w/Axciter Transmitter

CU100BTD w/Axciter Transmitter Block Diagram..... 1312647

CU100BTD w/Axciter Transmitter Interconnect

NOTE: The following systems have external amplifier trays.

CU250BRD/BTD Innovator 250 Watt Regenerative Translator/System
(Consists of a CU50BRD/BTD Tray driving a CU250, 250 Watt Amplifier Tray)

CU250BRD/BTD Block Diagram	
CU250BRD/BTD Interconnect	
CU250BRD/BTD Racking Plan	1312889

CU250, 250 Watt ATSC Amplifier Tray

CU250, 250 Watt Amplifier Tray Block Diagram	
CU250, 250 Watt Amplifier Tray Interconnect	

CU500BRD/BTD Innovator 500 Watt Regenerative Translator/System
(Consists of a CU50BRD/BTD Tray driving a CU500, 500 Watt Amplifier Tray)

CU500BRD/BTD Block Diagram	
CU500BRD/BTD Interconnect	
CU500BRD/BTD Racking Plan	1312530

CU1000BRD/BTD Innovator 1000 Watt Regenerative Translator/System
(Consists of a CU50BRD/BTD Tray driving (2) CU500, 500W Amplifier Trays.)

CU1000BRD/BTD Block Diagram	
CU1000BRD/BTD Interconnect	

CU1500BRD/BTD Innovator 1500 Watt Regenerative Translator/System
(Consists of a CU50BRD/BTD Tray driving (3) CU500, 500W Amplifier Trays.)

CU1500BRD/BTD Block Diagram	
CU1500BRD/BTD Interconnect	
CU1500BRD/BTD Racking Plan	1312912

CU1800BRD/BTD Innovator 1800 Watt Regenerative Translator/System
(Consists of a CU50BRD/BTD Tray driving (4) CU500, 500W Amplifier Trays.)

CU1800BRD/BTD Block Diagram	
CU1800BRD/BTD Interconnect	
CU1800BRD/BTD Racking Plan	1312888

CU500, 500 Watt ATSC Amplifier Tray (Used with the CU500-CU1800 systems)

CU500, 500 Watt Amplifier Tray Block Diagram	1312558
CU500, 500 Watt Amplifier Tray Interconnect	1312557

APPENDIX B

Specifications Sheet

Low Power UHF ATSC Transmitter/Translator 5W - 1.8kW



Axcera designed the Innovator CX to provide broadcasters with a compact, affordable and high quality transmitter that will meet their needs like no other solution on the market. This advanced low power transmitter line uses the latest LDMOS devices for broadband operation across the entire UHF band, and can be configured as a DTV transmitter or regenerative translator. This allows users to minimize spare parts stock, which is especially important to multi-transmitter operators, and also enables simple and inexpensive channel changes.

Each very compact unit is completely contained within a single 3RU rackmount chassis, including exciter, up to 125W. Higher power levels are achieved through the addition of one or more of our compact rackmount power amplifiers.

Monitoring is simple with the traditional discrete interface or optional secure Web browser/SNMP interface, allowing users to access all transmitter operating and control parameters through any computer with Internet access.

Low Power UHF ATSC Transmitter/Translator 5W - 1.8kW

Specifications

General Output Parameters

Standard	ATSC
Impedance	50 Ohms
Bandwidth	6 MHz
Test Signal	Internal PRBS-23
Frequency Range ²	470 to 862 MHz
Frequency Stability w/ GPS	0.2 ppm (max. 30 day variation) 0.001 ppm
Regulation of Output Power	3%
SNR	32 dB (typical), 30 dB (min.)

Input Parameters (Transmitter)

Connector Type	BNC
Data Interface	
Input Rate	19.39 Mbps, 6 MHz Channel
Input Interface	SMPTE 310M (ASI optional)

Input Parameters (Translator)

Frequency Range	54 to 862 MHz
Connector Type	BNC
Impedance	50 Ohms
Level	-78 to -8 dBm
White Noise Threshold of Errors	Better than 15.5 dB
Equalization Range	Better than ±45 µsec

Options

- Main/Alternate with Auto Switch
- Dual Exciter/Controller with Auto Switch
- AC Surge Protector
- GPS Receiver
- Spare Parts Kit
- Climate Controlled Outdoor Enclosure
- Equipment Rack *(Included with CU1000BxD and higher)*
- ASI Input
- Output Coupler *(Post-filter, included with CU1000BxD and higher)*
- Dual Power Supply *(Model Specific)*
- Axciter Intelligent Modulator
 - Adaptive Precorrection
 - DTVision
 - ATSC Mobile DTV(M/H)
 - Bandwidth Enhancement Technology (BET)
- Web Interface
- SNMP Interface

¹ Other power levels available upon request

² Consult factory for other frequencies, voltages or altitudes

³ Rackmount chassis are 19"(48 cm) wide, 25"(63 cm) deep.
Some dimensions do not include output filter. Consult Axcera for filter dimensions

Model Information

Model Numbers	CU5BTD	CU30BTD	CU50BTD	CU100BTD	CU125BTD	CU250BTD	CU500BTD	CU1000BTD	CU1600BTD	CU1800BTD
	CU5BRD	CU30BRD	CU50BRD	CU100BRD	CU125BRD	CU250BRD	CU500BRD	CU1000BRD	CU1600BRD	CU1800BRD
Power Output <i>(measured after mask filter)</i>	5W	30W	50W	100W	125W	250W	500W	1kW	1.6kW	1.8kW
Power Consumption	180W	300W	475W	780W	900W	1.7kW	3.4kW	6.3kW	9.7kW	11kW
Input Power										
Line Voltage	115V/230V+10%/-15%				230V+10%/-15%					
Power Requirements	Single Phase, 50 or 60 Hz									
Size (H x W x D) ³										
Inches	3RU				9RU			55 x 22 x 34		76 x 22 x 34
Centimeters								140 x 56 x 86		193 x 56 x 86
Weight (lbs/kg)	21/11	30/14	35/16	38/17	38/17	110/50	125/57	300/136	350/159	450/204
Maximum Altitude ²	8500 ft. (2600m) AMSL									
Operational Temperature Range	0 to +50°C, derate 2°C/1000 ft.									
Operational Humidity Range	0% to 95% non-condensing									

Specifications published here are current as of the date of publication of this document. Because we are continuously improving our products, Axcera reserves the right to change specifications without prior notice. At any time, you may verify product specifications by contacting our office. Axcera views its patent portfolio as an important corporate asset and vigorously enforces its patents. Products or features contained herein may be covered by one or more U.S. or foreign patents.