

Innovator™ HX Series

Digital UHF
Solid State
Transmitter

Volume 1
System and Exciter/Control

AXCERA, LLC

103 FREEDOM DRIVE • P.O. BOX 525 • LAWRENCE, PA 15055-0525 USA

(724) 873-8100 • FAX (724) 873-8105

www.axcera.com • service@axcera.com



TABLE OF CONTENTS

CHAPTER 1 INTRODUCTION

SECTION	PAGE
1.1 Manual Overview	1-1
1.2 Assembly Designators	1-1
1.3 Safety	1-1
1.4 Contact Information.....	1-2
1.5 Material Return Procedure	1-2
1.6 Limited One-Year Warranty for Axcera Products.....	1-3

CHAPTER 2 SYSTEM DESCRIPTION AND REMOTE CONTROL CONNECTIONS

2.0 System Overview	2-1
2.1 HX Exciter Description.....	2-1
2.1.1 Pre Filter Sample.....	2-2
2.1.2 Post Filter Sample	2-2
2.2 UHF Amplifier Cabinet Assembly	2-2
2.3 RF Output Assemblies	2-2
2.4 Exciter Amplifier Chassis Assembly.....	2-4
2.4.1 Control & Monitoring/Power Supply Module	2-4
2.4.2 Exciter Power Amplifier Module	2-5
2.5 Control and Status.....	2-6
2.5.1 Front Panel LCD Display Screens.....	2-6
2.6 System Operation.....	2-6
2.6.1 Principles of Operation	2-6
2.7 Maintenance	2-7
2.8 Customer Remote Connections	2-8

CHAPTER 3 SITE CONSIDERATIONS, INSTALLATION AND SETUP PROCEDURES

3.1 Site Considerations.....	3-1
3.2 Unpacking the Control/Exciter and Amplifier Cabinets.....	3-4
3.3 Installing of the Cabinets.....	3-5
3.3.1 Exciter/Control Cabinet	3-6
3.3.2 Placement and Assembling of the UHF Amplifier Cabinets	3-6
3.3.3 Blower Connections to TB1	3-6
3.4 AC Input.....	3-6
3.4.1 Main AC Connection to the Control/Exciter Cabinet	3-7
3.4.2 Main AC Connections to each of the Amplifier Cabinets.....	3-7
3.5 Setup and Operation.....	3-7
3.5.1 Input Connections	3-7
3.6 Initial Turn On.....	3-9
3.6.1 Driver Amplifier Front Panel LED Indicators	3-9
3.6.1.1 Upconverter Module LEDs on Front Panel.....	3-9
3.6.1.2 Controller Module LEDs on Front Panel	3-9
3.6.1.3 Power Amplifier Module LEDs on Front Panel	3-9
3.6.2 Front Panel Screens for the Driver Amplifier Chassis Assembly	3-10
3.6.3 Front Panel Touch Screens for the UHF Transmitter	3-18
3.6.4 Operation Procedure.....	3-23

TABLE OF CONTENTS (continued)

SECTION	PAGE
CHAPTER 4 CIRCUIT DESCRIPTIONS	
4.1 (R1) Control/Exciter Cabinet Assembly	4-1
4.1.1 Dual Peak Detector Board	4-1
4.1.2 Serial Loop-Thru Board	4-1
4.2 Driver/Amplifier Chassis Assembly	4-2
4.2.1 Control Monitoring/Power Supply Module	4-2
4.2.1.1 Power Protection Board.....	4-2
4.2.1.1.1 +12 VDC Circuits	4-2
4.2.1.1.2 -12 VDC Circuits	4-3
4.2.1.2 Control Board	4-3
4.2.1.2.1 Schematic Page 1	4-3
4.2.1.2.2 Schematic Page 2	4-4
4.2.1.2.3 Schematic Page 3	4-4
4.2.1.2.4 Schematic Page 4	4-4
4.2.1.2.5 Schematic Page 5	4-5
4.2.1.3 Switch Board	4-5
4.2.1.4 Switching Power Supply Assembly	4-6
4.2.2 Driver Power Amplifier Assembly Module	4-6
4.2.2.1 1 Watt UHF Module Assembly	4-6
4.2.2.2 1 Watt UHF Amplifier Board.....	4-6
4.2.2.3 UHF Module Assembly	4-7
4.2.2.4 Coupler Board Assembly	4-7
4.2.2.5 Amplifier Control Board.....	4-7
4.2.2.5.1 Schematic Page 1	4-7
4.2.2.5.2 Schematic Page 2	4-8
4.2.2.5.3 Current Monitoring Sections of the Board.....	4-8
4.2.2.5.4 Schematic Page 3 Digital & Reflected Power Detectors ..	4-9
CHAPTER 5 DETAILED ALIGNMENT PROCEDURES	
5.1 System Preparation	5-1
5.2 Module Replacement.....	5-1
5.3 Initial Test Setup.....	5-1
5.4 Setting Up the Output Power of the Transmitter.....	5-2
5.4.1 Setting Up of AGC 1	5-2
5.4.2 Setting Up of AGC 2	5-3
5.4.3 Setting Up of Overdrive Threshold.....	5-3
5.4.4 Setting Up Axciter Relay Sample Values.....	5-3
5.4.5 Upconverter Downconverter Adjustment.....	5-4
5.5. System Calibration of Forward and Reflected Powers using the HX Driver ...	5-4
5.5.1 Forward Power Calibration.....	5-4
5.5.2 Reflected Power Calibration	5-4

TABLE OF CONTENTS (continued)

APPENDICES

APPENDIX A SYSTEM SPECIFICATIONS

APPENDIX B SYSTEM DRAWINGS AND PARTS LISTS

APPENDIX C CONTROL CABINET DRAWINGS AND PARTS LISTS

APPENDIX D UHF DRIVER/AMPLIFIER ASSEMBLY
DRAWINGS AND PARTS LISTS

FIGURE	LIST OF FIGURES	PAGE
1-1	Brady Marker Identification Drawing.....	1-1
2-1	Driver/Amplifier Chassis Assembly Front View	2-3
2-2	Driver/Amplifier Chassis Assembly Rear View	2-8
3-1	1 kW Minimum Ventilation Configuration.....	3-4
3-2	Typical Front View 15 kW	3-5
3-3	Typical Front View UHF Amplifier Cabinet	3-6
3-4	TB1 Fan Control Connections	3-6
3-5	AC Input Connections to Control/Exciter Cabinet.....	3-7
3-6	AC Input Connections to Amplifier Cabinet	3-7
3-7	Rear View HX Series Digital Driver/Amplifier	3-8
3-8	Control/Exciter Cabinet Screen	3-18
3-9	Amplifier Cabinet and Transmitter Configuration Screen	3-19
3-10	Amplifier Cabinet Screen w/System Error List.....	3-20
3-11	Control Cabinet Screen w/System Error List	3-21
3-12	Serial Port Configuration Screen.....	3-22
5-1	Axciter Upconverter Main Screen.....	5-3

LIST OF TABLES

TABLE		PAGE
2-1	HX Series Trays and Assemblies.....	2-3
2-2	Controller/Power Supply Front Panel Display	2-4
2-3	Controller/Power Supply Front Panel Status Indicators	2-4
2-4	Controller/Power Supply Front Panel Control Adjustments.....	2-5
2-5	Power Amplifier Front Panel Status Indicators.....	2-5
2-6	Power Amplifier Front Panel Control Adjustments.....	2-6
2-7	Power Amplifier Front Panel Samples	2-6
2-8	HX Series Chassis Customer Remote Connections	2-8
3-1	HX Series Transmitter AC Input and Current Requirements.....	3-1
3-2	Rear Chassis Connections for HX Series Digital Transmitter	3-8
HX Series Driver/Amplifier Controller Menu Screens		3-10
3-3	Menu 01 Splash Screen #1.....	3-10
3-4	Menu 02 Splash Screen #2.....	3-10
3-5	Menu 10 Main Screen	3-10
3-6	Menu 11 Error List Access Screen.....	3-11
3-7	Menu 12 Transmitter Device Data Access Screen.....	3-11
3-8	Menu 13 Transmitter Configuration Access Screen.....	3-11
3-9	Menu 20 Error List Display Screen	3-12
3-10	Menu 30 Transmitter Device Details Screen	3-12
3-11	Menu 30-1 System Details Screens.....	3-12
3-12	Transmitter Device Parameters Detail Screens	3-13
3-13	Menu 40 Authorized Personnel Screen	3-14
3-14	Menu 40-1 Transmitter Set Up: Power Control Screen	3-15
3-15	Menu 40-3 Transmitter Set Up: Model Select Screen	3-15
3-15	Menu 40-3 Transmitter Set Up: Model Select Screen	3-15
3-16	Menu 40-4 Transmitter Set Up: Upconverter Channel Select Screen	3-15
3-17	Menu 40-5 Transmitter Set Up: Serial Address Screen	3-16
3-18	Menu 40-5 Transmitter Set Up: System Forward Power Cal. Screen...	3-16
3-19	Menu 40-9 Transmitter Set Up: System Rfltd. Power Cal. Screen	3-16
3-20	Menu 40-13 Transmitter Set Up: Min Fw Pwr Fault Threshold Screen	3-16
3-21	Menu 40-14 Transmitter Set Up: Max Refl Power Flt Threshold Scrn	3-17
3-22	Menu 40-18 Transmitter Set Up: Inner Loop Gain Control Screen....	3-17
3-23	Menu 40-19 Transmitter Set Up: Amplifier Module Control Screen...	3-17
3-24	Menu 40-19 Transmitter Set Up: Remote Command Control Screen	3-17
4-1	DIP Switch Settings for SW2 located on Exciter Control Board.....	4-4
4-2	Module OK LED Red and Blinking Interpretation.....	4-7

Chapter 1 Introduction

The Innovator™ HX Series Digital UHF Transmitter is comprised of two cabinet types, the exciter/control cabinet and the UHF amplifier cabinet. The Innovator™ HX Series Transmitter includes one or more UHF Amplifier cabinets depending on the power configuration ordered.

1.1 Manual Overview

This instruction manual is divided into two volumes. **Volume 1** contains information on the System and Control Cabinet and **Volume 2** contains information on the UHF Amplifier Cabinet.

Volume 1 contains five chapters and supporting appendices. **Chapter 1**, Introduction, contains information on safety, return procedures, and warranties. **Chapter 2** contains the system and assembly descriptions. **Chapter 3** describes the installation and set up procedures and the operation of the overall transmitter. **Chapter 4** contains the detailed circuit descriptions of the boards and subassemblies that are contained in the transmitter. **Chapter 5** describes the alignment of the overall transmitter. **Appendix A** contains the system specifications. **Appendix B** contains the system drawings and parts list. **Appendix C** contains the Control Cabinet interconnects, schematics, assembly drawings and parts lists. **Appendix D** contains the driver/amplifier chassis assembly interconnects, schematics, assembly drawings and parts lists.

1.2 Assembly Designators

Axcera has assigned assembly numbers, Ax designations, where x=1,2,3...etc, to all assemblies, modules, and boards in the system. These designations are referenced in the text of this manual and shown on the block diagrams and

interconnect drawings provided in the appendices. The Block Diagrams, Interconnects, Schematics, Assembly Drawings and Parts Lists are arranged in increasing numerical order in the appendices. Section titles in the text for assembly or module descriptions or alignment procedures contain the associated part number(s) and the relevant appendix that contains the drawings for that item.

The cables that connect between the boards within a tray or assembly and that connect between the trays, racks and cabinets are labeled using Brady markers. Figure 1-1 is an example of a Brady marked cable. There may be as few as two or as many as four Markers on any one cable. These Brady markers are read starting farthest from the connector. If there are four Brady Markers, this marker is the transmitter number such as transmitter 1 or Transmitter 2. The next or the farthest Brady Marker is the rack or cabinet number on an interconnect cable or the board number within a tray. The next number on an interconnect cable is the Tray location or number. The Brady marker closest to the connector is the Jack or Connector number on an interconnect cable or the jack or connector number on the board within a tray.

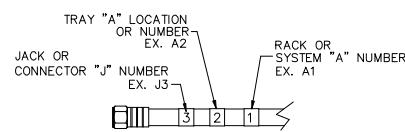

Figure 1-1 Brady Marker Identification Drawing

1.3 Safety

It is important that any user of this equipment read all of the instructions, especially the safety information in this chapter, before operating the transmitter.

Products manufactured by Axcera are designed to be easy to use and repair while providing protection from electrical and mechanical hazards. Listed throughout the manual are notes, cautions, and warnings concerning possible safety hazards that may be encountered while operating or servicing the product. Please review these warnings and familiarize yourself with the operation and servicing procedures before working on the product.

Read All Instructions – All of the operating and safety instructions should be read and understood before operating this equipment.

Retain Manuals – The manuals for the equipment should be retained at the site in which the equipment is operating for future reference. We provide two sets of manuals for this purpose; one set can be left at the office while one set can be kept at the site.

Heed all Notes, Warnings, and Cautions – All of the notes, warnings, and cautions listed in this safety section and throughout the manual must be followed.

Follow Instructions – All of the operating and use instructions for the product should be followed.

Cleaning – Unplug or otherwise disconnect all power from the equipment before cleaning. Do not use liquid or aerosol cleaners. Use a damp cloth for cleaning.

Servicing – Do not attempt to service this product yourself until becoming familiar with the equipment. If in doubt, refer all servicing questions to qualified Axcera service personnel.

Replacement Parts – When replacement parts are needed, be sure that the parts have the same functional and performance characteristics as the original part. Unauthorized substitutions may result in fire, electric shock, or other

hazards. Please contact the Axcera Technical Service Department if you have any questions regarding service or replacement parts.

1.4 Contact Information

The Axcera Field Service Department can be contacted by phone at **1-724-873-8100** or by fax at **1-724-873-8105**.

Before calling Axcera, please be prepared to supply the Axcera technician with answers to the following questions. This will save time and help ensure the most direct resolution to the problem.

1. What are the Customers' Name and call letters?
2. What are the model number and type of transmitter?
3. Is the transmitter digital or analog?
4. How long has the transmitter been on the air? (Approximately, when was the transmitter installed?)
5. What are the symptoms being exhibited by the transmitter? Include the current control/power supply LCD and touch screen readings. Also the status of LEDs on the front panels of the modules. If possible, include the control/power supply LCD and touch screen readings before the problem occurred.

1.5 Material Return Procedure

To insure the efficient handling of equipment or components that have been returned for repair, Axcera requests that each returned item be accompanied by a Return Material Authorization Number (RMA#). An RMA# can be obtained from any Axcera Service Engineer by contacting the Axcera Technical Service Department at 1-724-873-8100 or by fax at 1-724-873-8105. This procedure applies to all items sent to the Technical Service Department regardless of whether the item was originally manufactured by Axcera.

When equipment is sent to the field on loan, an RMA# is included with the unit. The RMA# is intended to be used when the unit is returned to Axcera. In addition, all shipping material should be retained for the return of the unit to Axcera. Replacement assemblies are also sent with an RMA# to allow for the proper routing of the exchanged hardware. Failure to close out this type of RMA# will normally result in the customer being invoiced for the value of the loaner item or the exchange assembly.

When shipping an item to Axcera, please include the RMA# on the packing list and on the Axcera-provided shipping container. The packing slip should also include contact information and a brief description of why the unit is being returned.

Please forward all RMA items to:

**Axcera
Customer Service Department
103 Freedom Drive
P.O. Box 525
Lawrence, PA 15055-0525 USA**

For more information, concerning this procedure, call the Axcera Customer Service Department.

Axcera can also be contacted through e-mail at service@axcera.com and on the Web at www.axcera.com.

1.6 Limited One-Year Warranty for Axcera Products

Axcera warrants each new product that it has manufactured and sold against defects in material and workmanship under normal use and service for a period of one (1) year from the date of shipment from Axcera's plant, when

operated in accordance with Axcera's operating instructions. This warranty shall not apply to tubes, fuses, batteries, or bulbs.

Warranties are valid only when and if (a) Axcera receives prompt written notice of breach within the period of warranty, (b) the defective product is properly packed and returned by the buyer (transportation and insurance prepaid), and (c) Axcera determines, in its sole judgment, that the product is defective and not subject to any misuse, neglect, improper installation, negligence, accident, or (unless authorized in writing by Axcera) repair or alteration. Axcera's exclusive liability for any personal and/or property damage (including direct, consequential, or incidental) caused by the breach of any or all warranties, shall be limited to the following: (a) repairing or replacing (in Axcera's sole discretion) any defective parts free of charge (F.O.B. Axcera's plant) and/or (b) crediting (in Axcera's sole discretion) all or a portion of the purchase price to the buyer.

Equipment furnished by Axcera, but not bearing its trade name, shall bear no warranties other than the special hours-of-use or other warranties extended by or enforceable against the manufacturer at the time of delivery to the buyer.

NO WARRANTIES, WHETHER STATUTORY, EXPRESSED, OR IMPLIED, AND NO WARRANTIES OF MERCHANTABILITY, FITNESS FOR ANY PARTICULAR PURPOSE, OR FREEDOM FROM INFRINGEMENT, OR THE LIKE, OTHER THAN AS SPECIFIED IN PATENT LIABILITY ARTICLES, AND IN THIS ARTICLE, SHALL APPLY TO THE EQUIPMENT FURNISHED HEREUNDER.



WARNING!!!

◀ HIGH VOLTAGE ▶

DO NOT ATTEMPT TO REPAIR OR TROUBLESHOOT THIS EQUIPMENT UNLESS YOU ARE FAMILIAR WITH ITS OPERATION AND EXPERIENCED IN SERVICING HIGH VOLTAGE EQUIPMENT. LETHAL VOLTAGES ARE PRESENT WHEN POWER IS APPLIED TO THIS SYSTEM. IF POSSIBLE, TURN OFF POWER BEFORE MAKING ADJUSTMENTS TO THE SYSTEM.

★ RADIO FREQUENCY RADIATION HAZARD ★

MICROWAVE, RF AMPLIFIERS AND TUBES GENERATE HAZARDOUS RF RADIATION THAT CAN CAUSE SEVERE INJURY INCLUDING CATARACTS, WHICH CAN RESULT IN BLINDNESS. SOME CARDIAC PACEMAKERS MAY BE AFFECTED BY THE RF ENERGY EMITTED BY RF AND MICROWAVE AMPLIFIERS. NEVER OPERATE THE TRANSMITTER SYSTEM WITHOUT A PROPERLY MATCHED RF ENERGY ABSORBING LOAD ATTACHED. KEEP PERSONNEL AWAY FROM OPEN WAVEGUIDES AND ANTENNAS. NEVER LOOK INTO AN OPEN WAVEGUIDE OR ANTENNA. MONITOR ALL PARTS OF THE RF SYSTEM FOR RADIATION LEAKAGE AT REGULAR INTERVALS.

EMERGENCY FIRST AID INSTRUCTIONS

Personnel engaged in the installation, operation, or maintenance of this equipment are urged to become familiar with the following rules both in theory and practice. It is the duty of all operating personnel to be prepared to give adequate Emergency First Aid and thereby prevent avoidable loss of life.



RESCUE BREATHING

1. Find out if the person is breathing.

You must find out if the person has stopped breathing. If you think he is not breathing, place him flat on his back. Put your ear close to his mouth and look at his chest. If he is breathing you can feel the air on your cheek. You can see his chest move up and down. If you do not feel the air or see the chest move, he is not breathing.

2. If he is not breathing, open the airway by tilting his head backwards.

Lift up his neck with one hand and push down on his forehead with the other. This opens the airway. Sometimes doing this will let the person breathe again by himself.

3. If he is still not breathing, begin rescue breathing.

-Keep his head tilted backward.
-Pinch nose shut.
-Put your mouth tightly over his mouth.
-Blow into his mouth once every five seconds
-DO NOT STOP rescue breathing until help arrives.

LOOSEN CLOTHING - KEEP WARM

Do this when the victim is breathing by himself or help is available. Keep him as quiet as possible and from becoming chilled. Otherwise treat him for shock.

BURNS

SKIN REDDENED: Apply ice cold water to burned area to prevent burn from going deeper into skin tissue. Cover area with a clean sheet or cloth to keep away air. Consult a physician.

SKIN BLISTERED OR FLESH CHARRED: Apply ice cold water to burned area to prevent burn from going deeper into skin tissue.

Cover area with clean sheet or cloth to keep away air. Treat victim for shock and take to hospital.

EXTENSIVE BURN - SKIN BROKEN: Cover area with clean sheet or cloth to keep away air. Treat victim for shock and take to hospital.

dBm, dBw, dBmV, dBμV, & VOLTAGE EXPRESSED IN WATTS

50 Ohm System

WATTS	PREFIX	dBm	dBw	dBmV	dBμV	VOLTAGE
1,000,000,000,000	1 TERAWATT	+150	+120			
100,000,000,000	100 GIGAWATTS	+140	+110			
10,000,000,000	10 GIGAWATTS	+130	+100			
1,000,000,000	1 GIGAWATT	+120	+ 99			
100,000,000	100 MEGAWATTS	+110	+ 80			
10,000,000	10 MEGAWATTS	+100	+ 70			
1,000,000	1 MEGAWATT	+ 90	+ 60			
100,000	100 KILOWATTS	+ 80	+ 50			
10,000	10 KILOWATTS	+ 70	+ 40			
1,000	1 KILOWATT	+ 60	+ 30			
100	1 HECTROWATT	+ 50	+ 20			
50		+ 47	+ 17			
20		+ 43	+ 13			
10	1 DECAWATT	+ 40	+ 10			
1	1 WATT	+ 30	0	+ 77	+137	7.07V
0.1	1 DECIWATT	+ 20	- 10	+ 67	+127	2.24V
0.01	1 CENTIWATT	+ 10	- 20	+ 57	+117	0.707V
0.001	1 MILLIWATT	0	- 30	+ 47	+107	224mV
0.0001	100 MICROWATTS	- 10	- 40			
0.00001	10 MICROWATTS	- 20	- 50			
0.000001	1 MICROWATT	- 30	- 60			
0.0000001	100 NANOWATTS	- 40	- 70			
0.00000001	10 NANOWATTS	- 50	- 80			
0.000000001	1 NANOWATT	- 60	- 90			
0.0000000001	100 PICOWATTS	- 70	-100			
0.00000000001	10 PICOWATTS	- 80	-110			
0.000000000001	1 PICOWATT	- 90	-120			

TEMPERATURE CONVERSION

$$^{\circ}\text{F} = 32 + [(9/5) ^{\circ}\text{C}]$$

$$^{\circ}\text{C} = [(5/9) (^{\circ}\text{F} - 32)]$$

USEFUL CONVERSION FACTORS

TO CONVERT FROM	TO	MULTIPLY BY
mile (US statute)	kilometer (km)	1.609347
inch (in)	millimeter (mm)	25.4
inch (in)	centimeter (cm)	2.54
inch (in)	meter (m)	0.0254
foot (ft)	meter (m)	0.3048
yard (yd)	meter (m)	0.9144
mile per hour (mph)	kilometer per hour (km/hr)	1.60934
mile per hour (mph)	meter per second (m/s)	0.44704
pound (lb)	kilogram (kg)	0.4535924
gallon (gal) U.S. liquid	liter	3.7854118
(One U.S. gallon equals 0.8327 Canadian gallon)		
fluid ounce (fl oz)	milliliters (ml)	29.57353
British Thermal Unit	watt (W)	0.2930711
		per hour (Btu/hr)
horsepower (hp)	watt (W)	746

NOMENCLATURE OF FREQUENCY BANDS

FREQUENCY RANGE	DESIGNATION
3 to 30 kHz	VLF - Very Low Frequency
30 to 300 kHz	LF - Low Frequency
300 to 3000 kHz	MF - Medium Frequency
3 to 30 MHz	HF - High Frequency
30 to 300 MHz	VHF - Very High Frequency
300 to 3000 MHz	UHF - Ultrahigh Frequency
3 to 30 GHz	SHF - Superhigh Frequency
30 to 300 GHz	EHF - Extremely High Frequency

LETTER DESIGNATIONS FOR UPPER FREQUENCY BANDS

LETTER	FREQ. BAND
L	1000 - 2000 MHz
S	2000 - 4000 MHz
C	4000 - 8000 MHz
X	8000 - 12000 MHz
Ku	12 - 18 GHz
K	18 - 27 GHz
Ka	27 - 40 GHz
V	40 - 75 GHz
W	75 - 110 GHz

RETURN LOSS VS. VSWR

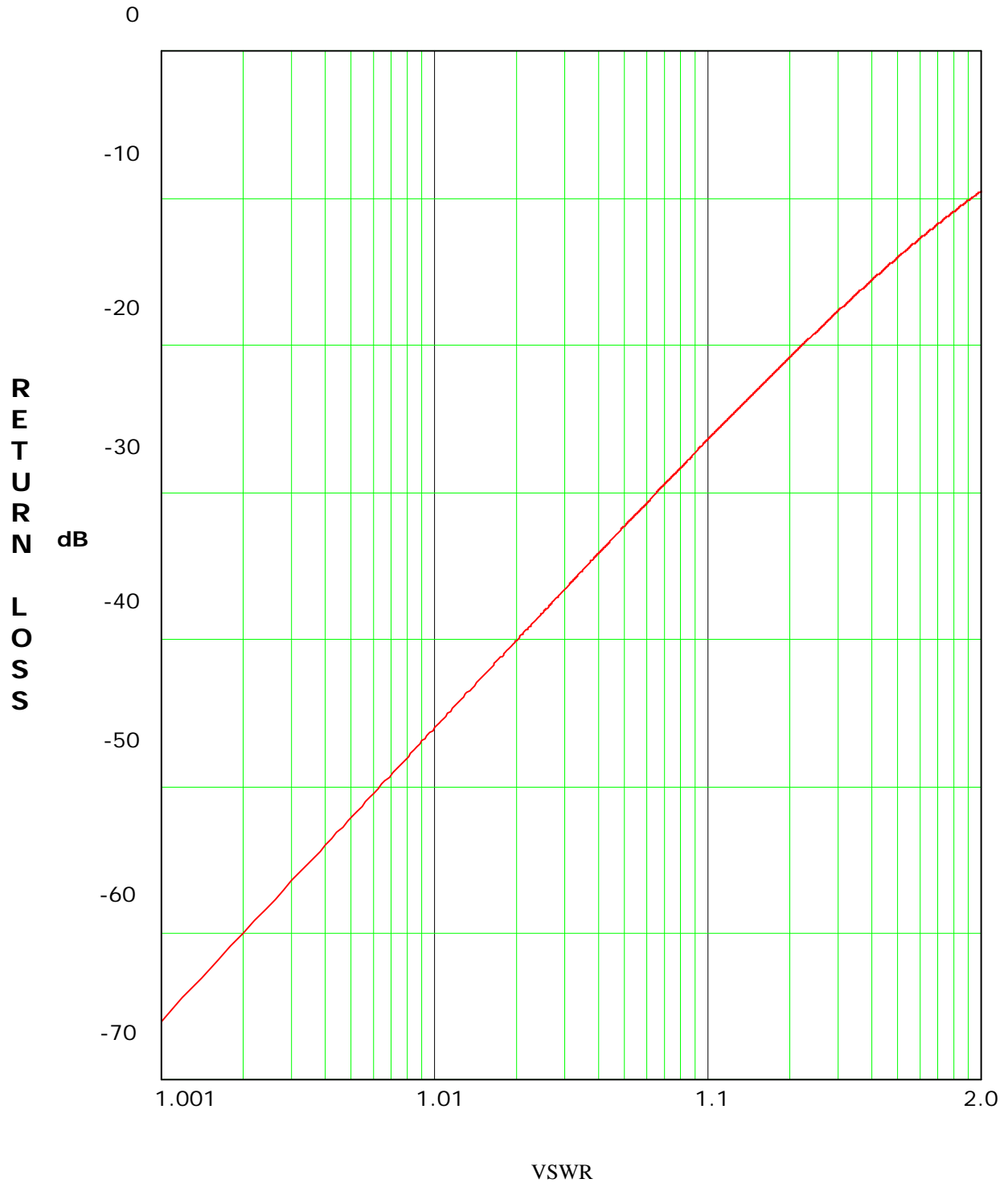

ABBREVIATIONS/ACRONYMS

AC	Alternating Current	IF	Intermediate Frequency
AFC	Automatic Frequency Control	LED	Light emitting diode
ALC	Automatic Level Control	LSB	Lower Sideband
AM	Amplitude modulation	MPEG	Motion Pictures Expert Group
AGC	Automatic Gain Control	O/P	Output
ATSC	Advanced Television Systems Committee	PLL	Phase Locked Loop
AWG	American wire gauge	PCB	Printed circuit board
BER	Bit Error Rate	QAM	Quadrature Amplitude Modulation
BW	Bandwidth	SMPTE	Society of Motion Picture and Television Engineers
DC	Direct Current	VSF	Vestigial Side Band
D/A	Digital to analog		
DTV	Digital Television		
dB	Decibel		
dBm	Decibel referenced to 1 milliwatt		
dBmV	Decibel referenced to 1 millivolt		
dBw	Decibel referenced to 1 watt		
FEC	Forward Error Correction		
FM	Frequency modulation		
Hz	Hertz		
ICPM	Incidental Carrier Phase Modulation		
I/P	Input		

Chapter 2 System Description and Remote Control Connections

2.0 System Overview

Each Innovator™ HX Series UHF transmitter system consists of an Exciter/Driver System Control Cabinet and one or more RF Power Amplifier (PA) Cabinets each of which has a maximum power output of 5 kW DTV. Volume 1, this volume, contains information on the system and the exciter/control cabinet. The information and drawings on the UHF Power Amplifier Cabinet are contained in Volume 2.

The Exciter/Driver System Control Cabinet contains a computer with a touch screen, keyboard and mouse and a UPS power supply. Also part of the exciter/driver cabinet are an HX Series Driver/Amplifier Assembly and an Axciter Modulator. An external Dual Peak Detector Board generates a forward and a reflected power sample for metering purposes in the driver/amplifier assembly. A Serial Loop-Thru board is part of the cabinet assembly and provides system serial interface connection to both the Axciter and the Driver/Amplifier Assembly. A relay is also part of the cabinet assembly and is used to switch the pre-filter and post-filter samples to the Axciter Modulator for use by the Adaptive Digital Equalization.

NOTE: Refer to the separate Axciter Modulator Instruction Manual for detailed information on the Axciter Modulator Tray and the Upconverter and Downconverter Modules mounted in the exciter/driver chassis assembly.

2.1 HX Exciter

The HX Exciter with Axciter accepts the SMPTE-310 encoded digital video and performs all processing necessary to create an ATSC compatible RF output.

The exciter is equipped with a high-speed digital signal processing system that monitors not only the incoming digital video signal but also the amplified RF signal before it is filtered and after it is filtered. The Axciter monitors the output of the RF amplifier cabinet or combiner, which is the pre filter sample (non-linear distortion), and the after filter sample (linear distortion), from the output of the DTV Filter. The Axciter automatically computes pre-correction information that is used to produce the highest quality over-the-air 8VSB signal output possible. This system is called Adaptive Digital Equalization.

The Exciter consists of the (A22) Axciter Modulator, the Axciter Upconverter module and the Axciter Downconverter module mounted in the Driver/Amplifier Assembly, the (A3) Driver/Amplifier Assembly and the (A4) Dual Peak Detector Board.

The output of the (A22) Axciter Modulator, at J40 the IF output jack (-12 dBm, .06 mW), connects to J15 the Modulated IF input jack on the (A3) Driver/Amplifier Assembly. The modulated IF connects to the Upconverter Module which produces a RF on channel frequency signal at J23 the Upconverter RF output jack on the rear of the driver/amplifier chassis assembly. The gain of the upconverter is adjustable and dependent on the number of UHF amplifier cabinets in the system. The output of the upconverter may be padded by a 6 dB attenuator for 3 cabinets or a 10dB attenuator for 1 or 2 cabinets. The RF is jumper cabled to J24 the IPA input jack on the driver/amplifier chassis assembly. The RF input ($\approx +6$ dBm, 4 mW 1 amp cab, or $\approx +9$ dBm, 8 mW 2 Amp Cab, or $\approx +10.8$ dBm, 12 mW 3 amp cab) is connected to the IPA assembly, which amplifies the RF that is connected to J25 the IPA RF output jack of the driver/amplifier assembly. The RF ($\approx +27$ dBm, 0.5 W 1 amp cab, or $\approx +30$ dBm, 1 W 2 amp cab, or $\approx +31.8$ dBm, 1.5

W 3 amp cab) is cabled to the RF Amplifier Cabinet or to a 2 way or 3 way splitter in multi-amplifier configurations.

2.1.1 Pre-Filter Sample (Non-Linear Distortion)

A forward power sample, pre-filtering, of the output of the UHF amplifier cabinet or the combiner is provided from the pre-filter coupler. The sample connects to J1, on the A47 relay. The relay is controlled by the Axciter Modulator through J7.

The selected output of the relay, either the Pre or Post filter sample, connects to the rear of (A3) the driver/amplifier chassis assembly at the SMA Jack J41 that is connected to the downconverter module for use in the adaptive equalization process.

2.1.2 Post-Filter Sample (Linear Distortion)

A forward power sample, after filtering, of the output of the transmitter is provided from the DTV mask filter. The sample connects to J2, on the A47 relay. The relay is controlled by the Axciter Modulator through J7.

The selected output of the relay, either the Pre or Post filter sample, connects to the rear of (A3) the driver/amplifier chassis assembly at the SMA Jack J41 that is connected to the downconverter module for use in the adaptive equalization process in the Axciter.

2.2 UHF Amplifier Cabinet Assembly

The PA cabinets are typically made up of a eight RF amplifier assemblies, using seven 2 way splitters, an 8 way combiner, a Top Power Supply Assembly #1, a Bottom Power Supply Assembly #2, two Transformers, two SCR Controllers, a 480 or 208 VAC Power Distribution Panel that also distributes the 110 VAC.

The RF input, (+27 dBm, 500 mW), from the Exciter or the two way or three way splitter connects to the Amplifier Cabinet at the (A14) 2 Way Splitter in an eight amplifier assembly cabinet. Each output of the 2 Way Splitter is split by another 2 Way Splitter, creating four outputs. Each of these outputs is split again by another Two Way Splitter creating eight total outputs, each (+18 dBm, 63 mW) that connect to the eight Power Amplifier Assemblies. Each PA Assembly has approximately +40.5 dB of gain and generates a RF output of (+58.5 dBm, 700 W). These eight RF outputs are combined in an 8 Way Combiner to produce an RF Output of (+67.2 dBm, 5.2 kW) DTV.

In an amplifier cabinet with six amplifier assemblies, the input connects to a 2 way splitter. Each output of the 2 Way Splitter is split by a 3 Way Splitter, creating six outputs. Each of these outputs (+18 dBm, 63 mW) connect to the six Power Amplifier Assemblies. Each PA Assembly has approximately +40.5 dB of gain and generates a RF output of (+58.5 dBm, 700 W). These six RF outputs are combined in a 6 Way Combiner to produce an RF Output of (+65.7 dBm, 3.7 kW) DTV.

In an amplifier cabinet with three amplifier assemblies, the input connects to a 3 way splitter. Each output of the 3 Way Splitter (+18 dBm, 63 mW) connect to the three Power Amplifier Assemblies. Each PA Assembly has approximately +40.5 dB of gain and generates a RF output of (+58.5 dBm, 700 W). These three RF outputs are combined in a 3 Way Combiner to produce an RF Output of (+62.6 dBm, 1.8 kW) DTV.

NOTE: Detailed information and drawings on the UHF Power Amplifier Cabinet are contained in Volume 2 of this Manual.

2.3 RF Output Assemblies

The RF outputs from the individual amplifier cabinets connect, in 5kW and higher power transmitters, to the (A40) RF combiner assembly. In Transmitters below

5 kW, the output of the amplifier cabinet connects directly to the (A41) coupler assembly and then to J1, the RF input jack on the (A42) DTV mask filter assembly. In 5kW and higher transmitters, the combined output of the (A40) combiner, at a 3-1/8" connector, is cabled through (A41) a coupler assembly to J1 the RF input jack on the (A42) DTV mask filter assembly. In all power level transmitters, the (A41) coupler supplies a forward pre-filter sample that is cabled to the Axciter relay mounted in the exciter control cabinet.

The (A42) DTV mask filter supplies forward and reflected power samples that are cabled to the Exciter Control

Cabinet. The forward sample connects to J1 on the (A4) dual peak detector board and then to the system controller mounted in the HX exciter/driver assembly where it is used for monitoring and control purposes.

The reflected sample from the DTV mask filter connects to the J2 on the (A4) dual peak detector board and then to the system controller mounted in the HX exciter/driver assembly where it is used for monitoring and control purposes.

The RF output of the (A42) DTV mask filter is the UHF on channel RF output of the transmitter that connects to the antenna for your system.

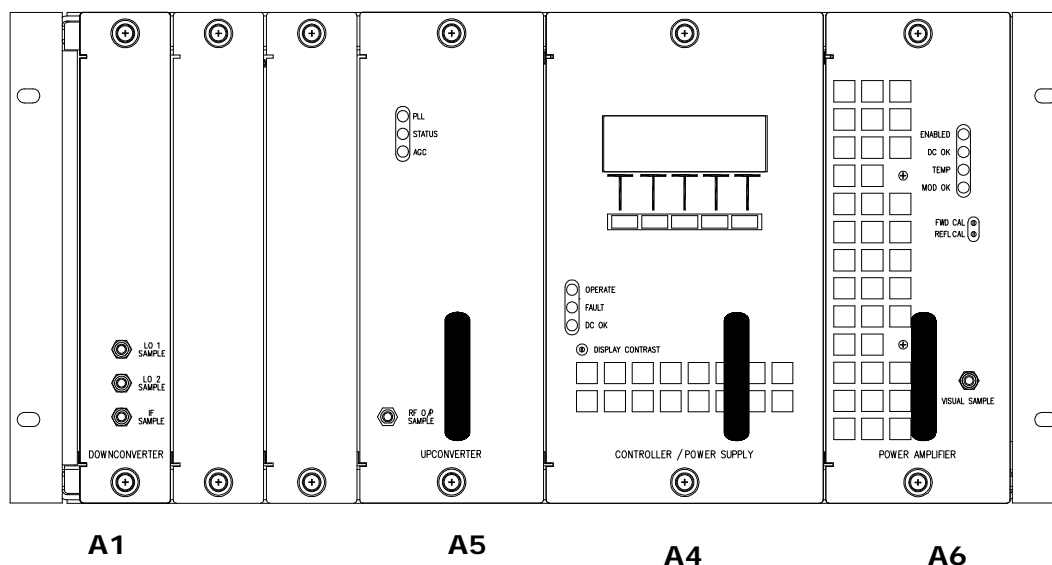

Figure 2-1: Driver/Amplifier Front View

Table 2-1: HX Series Trays and Assemblies

ASSEMBLY DESIGNATOR	TRAY/ASSEMBLY NAME	PART NUMBER
	Exciter Amplifier Chassis Assembly, HX Series	1305801 (110 VAC) Or 1305555 (220 VAC)
A11	Backplane Board, Axciter	1307307
A1	Downconverter Module, Axciter	1306852
A5	Upconverter Module, Axciter	1306850
A4	Control/Power Supply Module	1301936 (110 VAC) Or 1303229 (220 VAC)
A6	Power Amplifier Driver Module	1306019

**2.4 Exciter Amplifier Chassis
Assembly, HX Series, { (1305801,
110 VAC) or (1305555, 220 VAC);
Appendix D}**

The Digital HX Series exciter driver assembly is made up of the modules and assemblies as shown in Figure 2-1 and listed in Table 2-1.

The chassis assembly provides the spaces into which the individual modules slide, using tracks mounted on the top and bottom of the assembly. The chassis assembly is factory set for operation using 110 or 220 VAC as directed by the customer. In this system the modules include, (A4) a System Controller/Power Supply. The System Control Module plugs directly into a backplane board mounted at the rear of the chassis assembly. The backplane board (1307307) provides module to module interconnection as well as interconnection to remote command and control connectors at TB30 and TB31 on the rear of the assembly.

NOTE: Information and drawings on the Axciter, the Upconverter Module and the Downconverter Module are found in the separate Axciter Manual.

**2.4.1 (A4) Control/Power Supply
Module Assembly (110 VAC,
1301936 or 220 VAC, 1303229;
Appendix D)**

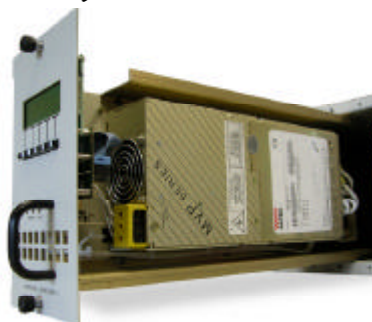

The (A4) Control & Monitoring/Power Supply Assembly is configured at the factory for operation at 110 VAC or 220 VAC. The assembly made up of a Control Board (1302021), a Power Protection Board (1302837), a Switch Board (1527-1406), and a LCD Display. The Assembly also contains a switching power supply that provides ±12 VDC to the rest of the modules in the chassis and +32 VDC to the Power Amplifier module.

The Assembly provides all transmitter control and monitoring functions. The Front panel LCD display, 20 char x 4 lines, allows monitoring of system parameters, including forward and reflected power, transistor currents, module temperatures and power supply voltages. The LCD screens are detailed in Chapter 3.

Table 2-2. Controller/Power Supply Display

DISPLAY	FUNCTION
LCD	A 4 x 20 display providing a four-line readout of the internal functions, external inputs, and status. See Chapter 3, Controller/Power Supply Display Screens, for a listing of displays.

Table 2-3. Controller/Power Supply Status Indicator

LED	FUNCTION
OPERATE (green)	When lit it indicates that the transmitter is in the Operate Mode. If transmitter is Muted the Operate LED will stay lit, the exciter/driver will remain in Operate, until the input signal is returned.
FAULT (red or green)	Red indicates that a problem has occurred in the transmitter. The transmitter will be Muted or placed in Standby until the problem is corrected.
DC OK (red or green)	Green indicates that the switchable fuse protected DC outputs that connect to the modules in the transmitter are OK.

Table 2-4. Controller/Power Supply Control Adjustments

POTENTIOMETERS	DESCRIPTION
DISPLAY CONTRAST	Adjusts the contrast of the display for desired viewing of screen.

2.4.2 (A6) Exciter Power Amplifier Module, UHF (1306019; Appendix D)



The (A6) Power Amplifier Module Assembly is made up of (A5) an Amplifier Control Board (1304774), (A4) a Coupler Board Assembly (1227-1316), (A1) 1 Watt UHF Module Assembly (1302891), and a RF Module Pallet Assembly, 250 Watts (1300116).

The Power Amplifier Module contains Broadband LDMOS amplifiers that cover the section of the UHF band that your channel is contained. The RF output of

the Axciter Upconverter is passed through the attenuator, (+6 to +10.8 dBm), and enters the module at J24. The DTV RF connects to J3 on the (A1) 1 Watt UHF Amplifier Module that contains a 1 Watt UHF Amplifier Board (1302761). The module has approximately 17 dB of gain. The RF output of the module (+27 dBm) at J4 connects to the RF input jack on (A3) the RF module pallet, Philips (1300116) that is made from the RF module pallet w/o transistors (1152336). The RF module pallet, Philips has approximately 12 dB of gain. The amplified RF output (+39 dBm) is cabled to J1 on (A4) the Coupler Board Assembly (1227-1316) that supplies a forward power sample to the (A5) Amplifier Control Board (1304774).

AGC Voltage, control and monitoring lines from the Amplifier Control Board are routed through the floating blind-mate connector to the Control & Monitoring/Power Supply module.

Table 2-5. Power Amplifier Status Indicator

LED	FUNCTION
ENABLED (Green)	When lit Green, it indicates that the PA is in the Operate Mode. If a Mute occurs, the PA will remain Enabled, until the input signal is returned.
DC OK (Green)	When lit Green, it indicates that the fuse protected DC inputs to the PA module are OK.
TEMP (Green)	When lit Green, it indicates that the temperature of the heatsink assembly in the module is below 78°C.
MOD OK (Green)	When lit Green, it indicates that the PA Module is operating and has no faults.
MOD OK (Red)	If the Module OK LED is Red and blinking a fault is present. 1 Blink indicates Amplifier Current Fault. 2 Blinks indicate Temperature Fault. 3 Blinks indicate +32V Power Supply Over Voltage Fault. 4 Blinks indicate +32V Power Supply Under Voltage Fault. 5 Blinks indicate Reflected Power Fault. 6 Blinks indicate +12V or -12V Power Supply Fault.

Table 2-6. Power Amplifier Control Adjustments

POTENTIOMETERS	DESCRIPTION
AVERAGE CAL	Adjusts the gain of the Average Power monitoring circuit
FORWARD CAL	Adjusts the gain of the Forward Power monitoring circuit
REFLECTED CAL	Adjusts the gain of the Reflected Power monitoring circuit

Table 2-7. Power Amplifier Samples

DISPLAY	FUNCTION
FORWARD SAMPLE	RF sample of the amplified DTV RF signal being sent out the module on J25. (~ - 10 dBm)

NOTE: The sample levels will vary depending on the output power level.

2.5 Control and Status

The control and status readings of the driver/amplifier chassis assembly are found by operating the front panel display screen on the front of the assembly. Detailed explanation on the screens information is found in Chapter 3 of this Volume.

2.5.1 Front Panel Display Screens

A 4 x 20 display located on the front of the Control & Monitoring/Power Supply Module is used in the HX Series driver/amplifier for control of the operation and display of the operating parameters of the transmitter. The LCD menu screens are detailed in Chapter 3 of this Volume.

2.6 System Operation

When the transmitter is in operate, as set by the menu screen on the touch screen, the following occurs. The +32 VDC stage of the Power Supply in the Control & Monitoring Module is enabled, the operate indicator on the front panel is lit and the DC OK on the front panel should also be green. The enable and DC OK indicators on the PA Module will also be green.

When the transmitter is in standby, the +32 VDC stage of the Power Supply in the Control & Monitoring Module is disabled, the operate indicator on the front panel will be extinguished and the DC OK on the front panel should remain green. The enable indicator on the PA Module is also extinguished.

If the transmitter does not switch to Operate when the operate menu is switched to Operate, check that all faults are cleared and that the remote control terminal block stand-by signal is not active.

2.6.1 Principles of Operation

Operating Modes

This transmitter is either operating or in standby mode. The sections below discuss the characteristics of each of these modes.

Operate Mode

Operate mode is the normal mode for the transmitter when it is providing RF power output.

Entering Operate Mode

Entering the operate mode can be initiated a few different ways by the transmitter control board. A list of the actions that cause the operate mode to be entered is given below:

- A low on the Remote Transmitter Operate line.
- User selects "OPR" using switches and menus of the front panel.
- Receipt of an "Operate CMD" over the serial interface.

There are several fault or interlock conditions that may exist in the transmitter that will prevent the

transmitter from entering the operate mode. These conditions are:

- Power Amplifier heat sink temperature greater than 78°C.
- Power Amplifier Interlock is high indicating that the amplifier is not installed.

Standby Mode

The standby mode in the transmitter indicates that the output amplifier of the transmitter is disabled.

Entering Standby Mode

Similar to the operate mode, the standby mode is entered using various means. These are:

- A low on the Remote Transmitter Stand-By line.
- Depressing the "STB" key on selected front panel menus.
- Receipt of a "Standby CMD" over the serial interface.

RF System Interlock

A RF System Interlock signal is provided through TB30-5. When this signal circuit is completed to ground such as through a wire between TB30-5 and TB30-15, the transmitter is allowed to operate. If this circuit is opened, the transmitter switches to a Mute condition. This circuit may be completed through coax relay contacts and/or reject load contact closures to assure the RF output system is available to receive the transmitter's output RF signal.

2.7 Maintenance

The Innovator HX Series driver/amplifier is designed with components that require little or no periodic maintenance except for the routine cleaning of the fans and the front panels of the modules.

The amount of time between cleanings depends on the conditions within the

transmitter room. While the electronics have been designed to function even if covered with dust, a heavy buildup of dust, dirt, or insects will affect the cooling of the components. This could lead to a thermal shutdown or the premature failure of the affected module.

When the front panels of the modules become dust covered, the module should be pulled out and any accumulated foreign material should be removed.

NOTE: To remove the driver/power amplifier module, mounted in the driver/amplifier assembly, the input and output cables must be removed from the rear of the module and also a 6/32" x 1/2" Philips screw, mounted between the two connectors, needs to be removed before the module will pull out. After removal of the screw, which is used to hold the module in place during shipping, it does not need to be replaced.

A vacuum cleaner, utilizing a small, wand-type attachment, is an excellent way to suction out the dirt. Alcohol and other cleaning agents should not be used unless you are certain that the solvents will not damage components or the silk-screened markings on the modules and boards. Water-based cleaners can be used, but do not saturate the components. The fans and heatsinks should be cleaned of all dust or dirt to permit the free flow of air for cooling purposes.

It is recommended that the operating parameters of the driver/amplifier be recorded from the LEDs on the modules and the LCD system metering on the control/monitoring module at least once a month. It is suggested that this data be retained in a rugged folder or envelope.

2.8 Customer Remote Connections

The remote monitoring and operation of the driver/amplifier is provided through jacks TB30 and TB31 located on the rear

of the chassis assembly. If remote connections are made to the transmitter, they must be made through plugs TB30 and TB31 at the positions noted on the transmitter interconnect drawing and Table 2-8. TB30 and 31 are 18 position terminal blocks that are removable from

their sockets to make connections easier. Just grasp and pull the connector straight out. After connections are made, replace the connector and push firmly to seat the connector in the socket.

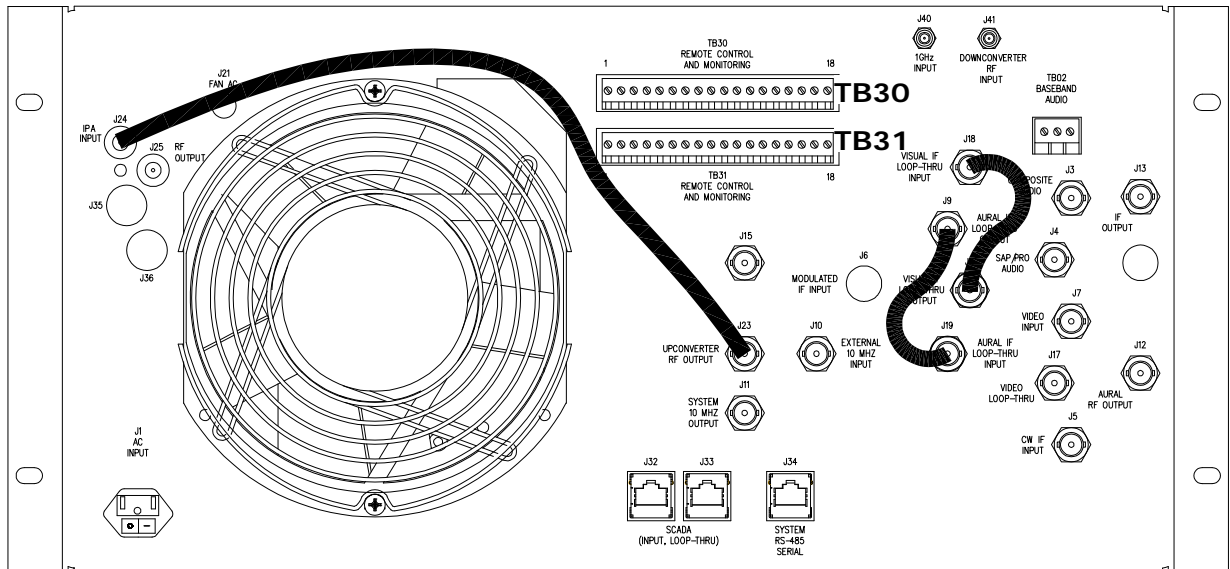

Figure 2-2. Driver/Amplifier Chassis Assembly Rear View

Table 2-8: HX Series Chassis Assembly Hard Wired Remote Interface Connections to TB30 or TB31, 18 pos. Terminal Blocks are located on the rear of the Driver/Amplifier Assembly

Signal Name	Pin Designations	Signal Type/Description
RMT Transmitter State	TB30-1	Discrete Open Collector Output - A low indicates that the Transmitter is in the operate mode.
RMT Transmitter Interlock	TB30-2	Discrete Open Collector Output - A low indicates the transmitter is OK or completes an interlock daisy chain. When the transmitter is not faulted, the interlock circuit is completed.
RMT Transmitter Interlock Isolated Return	TB30-3	Ground - Configurable ground return which can be either jumpered directly to ground or it can be the "source" pin of an FET so that the exciter interlock can be daisy chained with other transmitters. This signal does not directly interface to the microcontroller.
RMT Aux I/O 1	TB30-4	Spare to be used for future expansion.
RMT RF System Interlock	TB30-5	When this signal's circuit is completed to ground such as through a jumper between TB30-5 and TB30-15, the transmitter is allowed to operate. If this circuit is opened, the transmitter switches to a Mute condition. (See note at end of table)

Signal Name	Pin Designations	Signal Type/Description
RMT Transmitter Set to Operate CMD	TB30-6	Discrete Open Collector Input - A pull down to ground on this line indicates that the transmitter is to be placed into the operate mode.
RMT Transmitter Set to Stand-By CMD	TB30-7	Discrete Open Collector Input - A pull down to ground on this line indicates that the transmitter is to be placed into the standby mode.
RMT System Reflect Power	TB30-10	Analog Output (0 to 4.0 V). This is a buffered loop through of the calibrated "System Reflected Power " and indicates the transmitter's reflected output power. The scale factor is 25% = 3.2V.
RMT System Forward Power	TB30-11	Analog Output (0 to 4.0 V). This is a buffered loop through of the calibrated "System Forward Power ". Indicates the transmitter's Forward power. Scale factor is 100% = 3.2V.
RMT Spare 1	TB30-13	Spare to be used for future expansion.
RMT Spare 2	TB30-14	Spare to be used for future expansion
*Ground	TB30-15	Ground pin (Normally jumpered to TB30-5)
*RTN	TB30-17	±12 VDC returns
*System +12VDC	TB30-16	+12 VDC to the (A4) dual peak detector board.
*System -12VDC	TB30-18	-12 VDC to the (A4) dual peak detector.
Ground	TB31-1, 2, 6, 11 12, & 17	Ground pins
*RTN	TB31-12	Reflected and forward metering returns.
*System Reflect Power	TB31-13	Reflected Power Sample to the driver/amplifier obtained from the (A4) dual peak detector
*System Forward Power	TB31-14	Forward Power Sample to the driver/amplifier obtained from the (A4) dual peak detector

* Indicates that these connections are used in the system and are not available for remote use.

NOTE: The RMT RF System Interlock, at TB30-5, provides the customer with a means of connecting the transmitter to protection circuits, for the loads, thermal switches, combiners, or the antenna, in the output of your system, that will Mute the transmitter if the protection circuit opens. If the interlock is not used in the system, a jumper from TB30-5 to TB30-15, which is ground, needs to be connected to TB30. This jumper provides the RF System Interlock, which allows the transmitter to go to operate. Without the jumper, the transmitter will remain Muted.

Chapter 3 Site Considerations, Installation and Setup Procedures

Table 3-1: HX Series Transmitter AC Input and Current Requirements.

Transmitter	Voltage	Current
Less than 5 kW (2 cabinets)	120 VAC (1 connection)	20 Amps to the Control/Exciter Cabinet
	480 or 208 VAC, 3 phase (2 connections) & 120 VAC (1 connection)	Two 30 Amps 480 VAC or 50 Amps 208 VAC and One 1 Amp 120 VAC to the UHF Amplifier Cabinet
5 - 10 kW (3 cabinets)	120 VAC (1 connection)	20 Amps to the Control/Exciter Cabinet
	480 or 208 VAC, 3 phase (4 connections) & 120 VAC (1 connection)	Two 30 Amps 480 VAC or 50 Amps 208 VAC and One 1 Amp 120 VAC to each of the two UHF Amplifier Cabinets.
10-15 kW (4 cabinets)	120 VAC (1 connection)	20 Amps to the Control/Exciter Cabinet
	480 or 208 VAC, 3 phase (6 connections) & 120 VAC (1 connection)	Two 30 Amps 480 VAC or 50 Amps 208 VAC and One 1 Amp 120 VAC to each of the three UHF Amplifier Cabinets.
15-20 kW (5 cabinets)	120 VAC (1 connection)	20 Amps to the Control/Exciter Cabinet
	480 or 208 VAC, 3 phase (8 connections) & 120 VAC (1 connection)	Two 30 Amps 480 VAC or 50 Amps 208 VAC and One 1 Amp 120 VAC to each of the four UHF Amplifier Cabinets.
20-25 kW (6 cabinets)	120 VAC (1 connection)	20 Amps to the Control/Exciter Cabinet
	480 or 208 VAC, 3 phase (10 connections) & 120 VAC (1 connection)	Two 30 Amps 480 VAC or 50 Amps 208 VAC and One 1 Amp 120 VAC to each of the five UHF Amplifier Cabinets.
25-30 kW (7 cabinets)	120 VAC (1 connection)	20 Amps to the Control/Exciter Cabinet
	480 or 208 VAC, 3 phase (12 connections) & 120 VAC (1 connection)	Two 30 Amps 480 VAC or 50 Amps 208 VAC and One 1 Amp 120 VAC to each of the six UHF Amplifier Cabinets.
35-40 kW (9 cabinets)	120 VAC (1 connection)	20 Amps to the Control/Exciter Cabinet
	480 or 208 VAC, 3 phase (16 connections) & 120 VAC (1 connection)	Two 30 Amps 480 VAC or 50 Amps 208 VAC and One 1 Amp 120 VAC to each of the eight UHF Amplifier Cabinets.
45-50 kW (11 cabinets)	120 VAC (1 connection)	20 Amps to the Control/Exciter Cabinet
	480 or 208 VAC, 3 phase (20 connections) & 120 VAC (1 connection)	Two 30 Amps 480 VAC or 50 Amps 208 VAC and One 1 Amp 120 VAC to each of the ten UHF Amplifier Cabinets.

3.1 Site Considerations

There are special considerations that need to be taken into account before the Innovator HX Series Digital UHF

transmitter can be installed. For example, if the installation is completed during cool weather, a heat-related problem may not surface for many months, suddenly appearing during the

heat of summer. This section provides planning information for the installation and set up of the transmitter.

The AC input and current requirements for HX Series transmitters are shown in Table 3-1. Check that your site has the needed power requirements.

NOTES: The transmitter is factory set for operation using one 120 VAC to the Control/Exciter cabinet and two 480 VAC or 208 VAC, 3 phase and one 120 VAC connections to each UHF Amplifier Cabinet.

The HX Series Digital Transmitters are designed and built to provide long life with a minimum of maintenance. The environment in which they are placed is important and certain precautions must be taken. The three greatest dangers to the transmitter are heat, dirt, and moisture. Heat is usually the greatest problem, followed by dirt, and then moisture. Over-temperature can cause heat-related problems such as thermal runaway and component failure. Each amplifier module in the transmitter contains a thermal interlock protection circuit that will shut down that module until the temperature drops to an acceptable level.

A suitable environment for the transmitter can enhance the overall performance and reliability of the transmitter and maximize revenues by minimizing downtime. A properly designed facility will have an adequate supply of cool, clean air, free of airborne particulates of any kind, and no excessive humidity. An ideal environment will require temperature in the range of 40° F to 70° F throughout the year, reasonably low humidity, and a dust-free room. It should be noted that this is rarely if ever attainable in the real world. However, the closer the environment is to this design, the greater the operating capacity of the transmitter.

There are generally three sources of heat that must be considered. The first and most obvious is the heat from the

transmitter itself. The heat generated by the transmitter and other equipment must be temperature controlled or removed from the building. The heat from the amplifier cabinet is exhausted from the room by an 1800 CFM Blower for a single amplifier cabinet or a 3600 CFM Blower for two amplifier cabinets. The heat that is produced inside the room by the Control/Driver Cabinet and from the amplifier cabinet needs to be taken into consideration when cooling the room.

An example of calculating the capacity of the air conditioner needed to cool a site if all the heat and air produced by the transmitter is exhausted into the room. This amount can be determined for a 10 kW transmitter by subtracting the average power to the antenna (10 kW) from the AC input power (55 kW) and taking this number (45 kW) and then multiplying it by 3.41. This gives a result of 153,450, which is the BTUs to be removed every hour. 12,000 BTUs per hour equals one ton. Therefore, a 13-ton air conditioner will cool a 10 kW digital transmitter if all the air is exhausted into the room.

The second source of heat is other equipment in the same room. If exhausted into the room, this heat must also be cooled. The third source of heat is equally obvious but not as simple to determine an amount. This is the heat coming through the walls, roof, and windows on a hot summer day. Unless the underside is exposed, the floor is usually not a problem. Determining this number is usually best left up to a qualified HVAC technician. There are far too many variables to even estimate this number without reviewing the detailed drawings of the site that show all of the construction details. The sum of these three sources is the bulk of the heat that must be removed. There may be other sources of heat, such as personnel, and all should be taken into account. In a typical 10 kW digital transmitter site with the amplifier cabinet exhausted properly,

the cooling can be accomplished by a 1 ton air conditioner.

The following precautions should be observed regarding air conditioning systems:

1. Air conditioners have an ARI nominal cooling capacity rating. In selecting an air conditioner, do not assume that this number can be equated to the requirements of the site. Make certain that the contractor uses the actual conditions that are to be maintained at the site in determining the size of the air conditioning unit.
2. Do not have the air conditioner blowing directly onto the transmitter. Under certain conditions, condensation may occur on, or worse in, the transmitter.
3. Interlocking the transmitter with the air conditioner is recommended to keep the transmitter from operating without the necessary cooling.

While using ventilation alone is not recommended, the following general statements apply:

1. The inlet and outlet vents should be on the same side of the building, preferably the leeward side. As a result, the pressure differential created by wind will be minimized. Only the outlet vent may be released through the roof.
2. The inlet and outlet vents should be screened with 1/8-inch hardware cloth (preferred) or galvanized hardware cloth (acceptable).
3. The inlet and outlet should have automatic dampers that close any time the blower is off.
4. In those cases in which a transmitter is regularly off for a portion of each

day, a temperature-differential sensor that controls a small heater should be installed. This sensor will monitor inside and outside temperatures simultaneously. If the inside temperature falls to within 5° F of the outside temperature, the heater will come on. This will prevent condensation from forming, when the blower comes on, and should be used even in the summer.

5. A controlled air bypass system should be installed to prevent the temperature in the room from falling below 40° F during transmitter operation.
6. The blower supplied with the transmitter provides 1800 CFM of air flow for each amplifier cabinet.
NOTE: Higher elevations require more air flow to provide the same amount of cooling. Consult with Axcera on your blower requirements.
7. Regular maintenance of any filters can not be overemphasized.
8. It is recommended that a site plan be submitted to Axcera for comments before installation begins.

The information presented in this section is intended to serve only as a general guide and may need to be modified for unusually severe conditions.

See Figure 3-1 for a typical transmitter In and Out air flow configuration.

System interlocking and thermostat settings should be reviewed with Axcera. As with any equipment installation, it is always good practice to consult with the manufacturer when questions arise. Axcera can be contacted at (724) 873-8100.

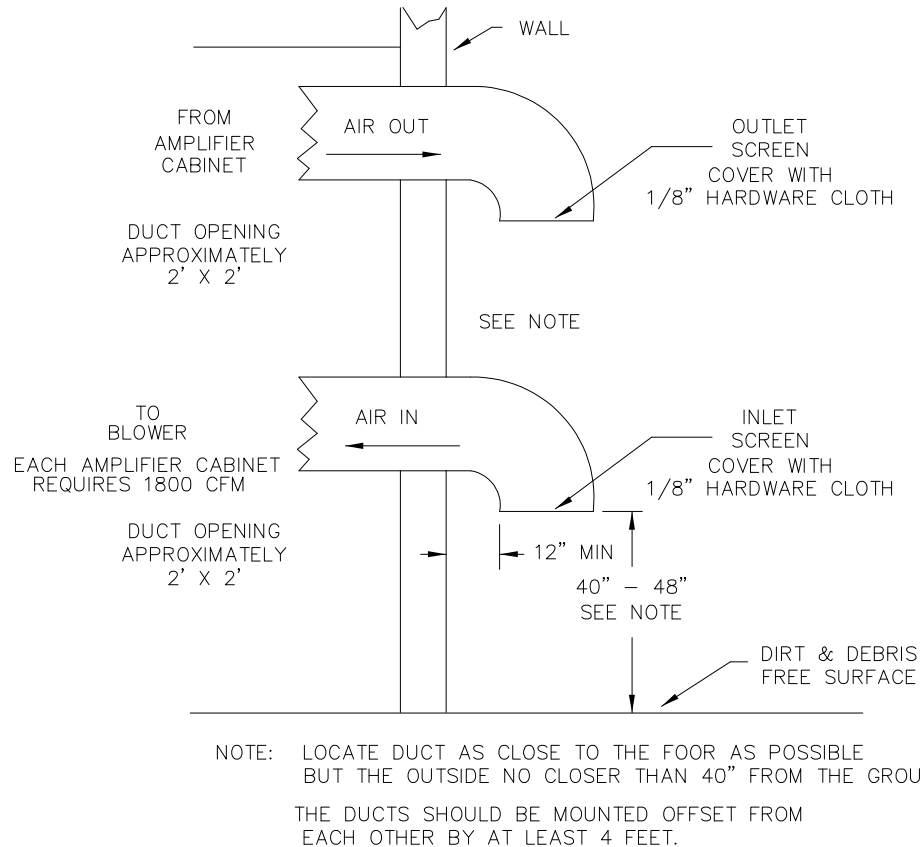

Figure 3-1. Typical Transmitter Air Flow Configuration

3.2 Unpacking the Control/Exciter Cabinet, Amplifier Cabinet(s), the RF Combiner, if present, and the DTV Mask Filter

While completing the installation of the transmitter, refer to the floor plan for your site for the location of the cabinets, combiner, if present, and mask filter.

Thoroughly inspect the cabinets, chassis with modules and all other materials upon their arrival. Axcera certifies that upon leaving our facility the equipment was undamaged and in proper working order. The shipping containers should be inspected for obvious damage that indicates rough handling. Remove the control/exciter cabinet, w/chassis and modules in place, the UHF amplifier cabinet(s), along with the combiner, if present, and mask filter, from the crates and boxes. Remove the straps that hold

the control/exciter cabinet to the shipping skid and slide the cabinet from the skid. Remove the plastic wrap and foam protection from around the cabinet. Do not remove any labeling or tags from any cables or connectors; these are identification markers that make assembly of the transmitter much easier. Check for dents and scratches or broken connectors, switches, display, or connectors. Any claims against in-transit damage should be directed to the carrier. Inform Axcera as to the extent of any damage as soon as possible. Open the rear door and carefully remove any packing material. Open the top touch screen door and bottom front door and check that the exciter/driver assembly and the touch screen and computer are undamaged. Open the tray containing the keyboard and mouse and check that they are undamaged. A key in the front of the computer, when turned clockwise,

gives access to the CD and floppy disk drives, mounted behind the flip down front panel of the computer.

Remove the straps that hold the amplifier cabinets to the shipping skids and slide them from the skids. Remove the plastic wrap and foam protection from around the cabinets. Do not remove any labeling or tags from any cables or connectors; these are identification markers that make assembly and identification of the transmitter much easier. Check for dents and scratches or broken connectors, switches, display, or connectors. Any claims against in-transit damage should be directed to the carrier. Inform Axcera as to the extent of any damage as soon as possible. Open the rear doors to the cabinets and inspect the interior for packing material and carefully remove any that is found.

3.3 Installation of the Cabinets

The cabinets should be positioned with consideration of the air intake and exhaust ducts that mount to the top of

each amplifier cabinet and access to the front of the amplifier cabinet for the installation and removal of the UHF amplifier assemblies. The opening of the rear door on the amplifier and control/exciter cabinets, as well as access to the exciter modules and UHF amplifier trays (including sliding them out for testing) should also be kept in mind.

The control/exciter and amplifier cabinets should be placed in position according to the floor plan drawing for your site. Position the R1 (C1) control/exciter cabinet to the left and even with the front of the R2 amplifier cabinet #1, taking into account the cabinet door alignment. In transmitters above 5 kW, position the R3 amplifier cabinet #2 to the right of amplifier #1 and position the R4 amplifier cabinet #3 to the right of amplifier #2, if present. Refer to Figure 3-2 for a 15 kW typical cabinet location. Predrilled mounting holes and hardware are provided in the cabinets for bolting them together. The hardware is provided in the installation kit.

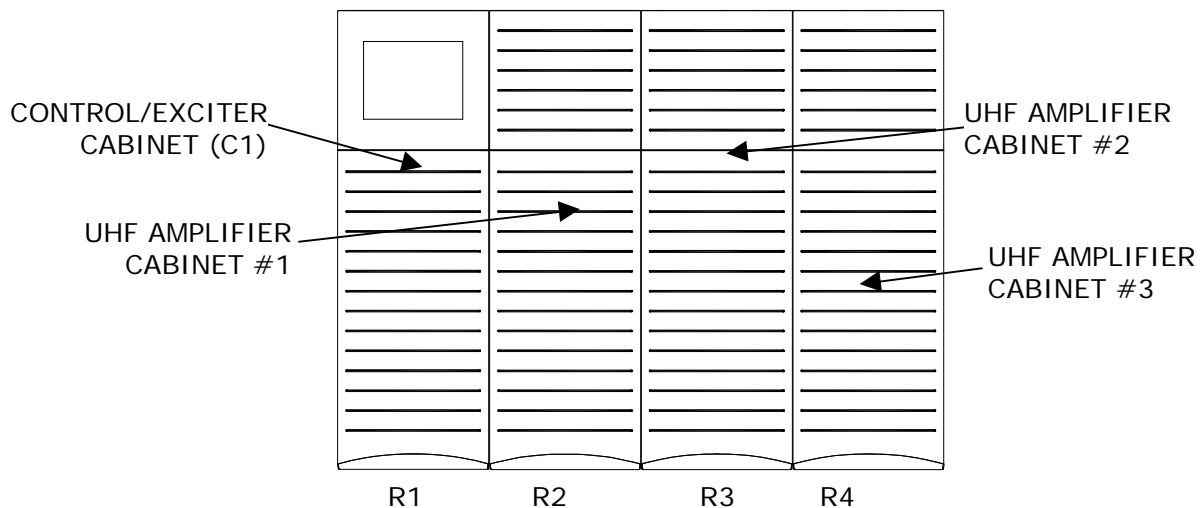

Figure 3-2. 15kW Typical Front View

3.3.1 Exciter/Control Cabinet

The Exciter/Control Cabinet is shipped with all assemblies installed. The driver/amplifier modules are mounted to the chassis assembly with slides that are on the top and the bottom of the modules. There are two thumb screws on the front panel that hold each of the modules in place.

NOTE: To remove the driver/power amplifier module, mounted in the exciter/driver assembly, the RF input and output cables must be removed from the rear of the module and also a 6/32" x 1/2" Philips screw, mounted between the connectors, needs to be removed before the module will pull out. After removal of the screw, which is used to hold the module in place during shipping, it does not need to be replaced.

3.3.2 Placement and Assembling of the UHF Amplifier Cabinets

When the UHF amplifier cabinets were packed at the factory, the individual UHF amplifier trays are removed from the cabinet and placed in boxes for shipment. The UHF amplifier trays must be replaced in the UHF amplifier cabinets. The individual trays are labeled as to their cabinet location.

They will be labeled with the rack number, R2 (UHF Amplifier #1) or in higher than 5 kW, R3 (UHF Amplifier #2) and the amplifier position number, 1 thru 8. An example of amp tray labeling is, 2-1. The amp tray labeled 2-1 will be placed in Rack #2 (UHF Amplifier Cabinet #1), amp position #1, the top left amp position. Refer to Figure 3-3 for a typical UHF Amplifier Cabinet racking plan.

Slide each of the UHF amplifier trays into the proper location(s) in the cabinet and seat firmly in place.

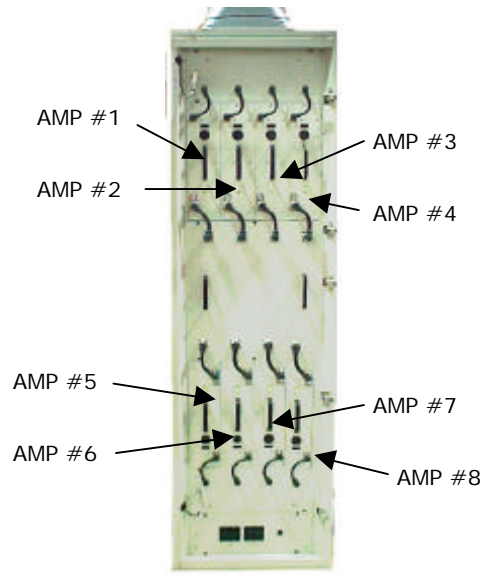

Figure 3-3: Typical 8 Amplifier UHF Amplifier Cabinet Front View

3.3.3 Blower Control Connection to TB1

Connect two 22AWG wires from the 3 position terminal block TB1 located in the rear of each Amplifier Cabinet, the top, right side to the fan control box on the blower assembly. TB1-1 is +12 VDC and TB1-3 is Blower Control. See Figure 3-4.

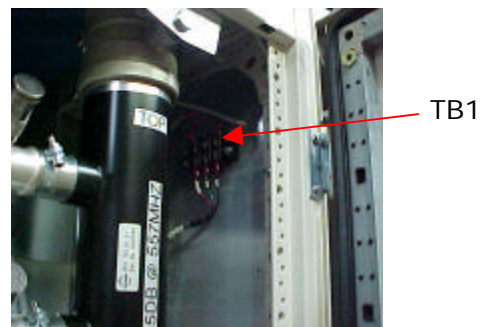

Figure 3-4: TB1 Fan Control Connections

3.4 AC Input

Once the cabinets and all air intake and exhaust ducts are in place, the main AC can be connected to the transmitter. A registered electrician should be used in connection of the electricity to the cabinets.

The AC input and current requirements for HX Series transmitters are as given in Table 3-1 located on page 1 of this chapter.

The AC Inputs to the cabinets of the transmitter connect to the terminal blocks located toward the rear, right side near the top of the control/exciter cabinet and located toward the rear, left side near the top of each amplifier cabinet.

3.4.1 Main AC Connection to the Control/Exciter Cabinet

In the Control/Exciter Cabinet, connect the 120 VAC to the TB1 terminal block, the AC Input Line 1 to terminal 1 on the terminal block, the AC Input Line 2 to terminal 2 on the terminal block and AC Input Ground to terminal 5 on the terminal block. (Refer to Figure 3-5)

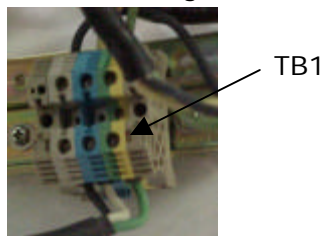

Figure 3-5: AC Input Connections to Control/Exciter Cabinet

3.4.2 Main AC Connections to each of the Amplifier Cabinets

Two 480 VAC or 208 VAC, 3 Phase inputs are required to each UHF Amplifier Cabinet. **NOTE:** In a 2.5 kW UHF amplifier cabinet just one 480 VAC or 208 VAC input is needed to the amplifier cabinet. Also one 120 VAC line input is needed for each UHF amplifier cabinet. In each UHF Amplifier Cabinet, connect one of the 480 VAC or 208 VAC inputs to the A1-A1 terminal block #1, the AC Input Line 1 to Line 1 on the terminal block, the AC Input Line 2 to Line 2, Line 3 to Line 3 and the AC Input Ground to Ground on the terminal block. Connect the other 480 VAC or 208 VAC input to the A2 terminal block #2, the AC Input Line 1 to Line 1 on the terminal block, the AC Input Line 2 to Line 2, Line 3 to Line 3 and the AC Input

Ground to Ground on the terminal block. **NOTE:** In 480 VAC or 208 VAC Delta configurations, connect the HIGH Leg, to Line 1 on the A1-A1 & A2 terminal blocks.

Connect the 120 VAC to the A1-A2 terminal block #3, Black to Line 2 on the terminal block, white of the AC Input to Line 3 on the terminal block and Green AC Input Ground to Ground, Neutral, on the terminal block. (Refer to Figure 3-6)

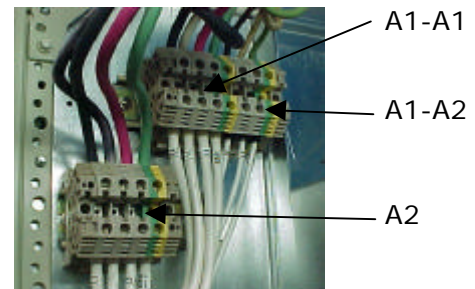

Figure 3-6: AC Input Connections to Amplifier Cabinets

This completes the unpacking and installation of the HX Series UHF television transmitter. Refer to the setup and operation procedures that follow before applying power to the transmitter.

3.5 Setup and Operation

Initially, the transmitter should be turned on with the RF output at the DTV Mask Filter terminated into a dummy load of at least the power rating of the transmitter. If a load is not available, check that the output of the DTV Mask Filter is connected to the antenna for your system.

3.5.1 Input Connections

The input connections to the transmitter are to the rear of the Control/Exciter Cabinet. The SMPTE 310 Input connects to J27 on the rear of the Axciter modulator tray.

The 10 MHz input from the external GPS, if used, connects to J9 on the Axciter Modulator tray. This 10 MHz turns off the internally generated 10 MHz. The 10

MHz from J12 on the Axciter connects to the 10 MHz input jack J10 on the rear of the Driver/Amplifier assembly.

Refer to the table and description that follows for detailed information on the input connections to the driver/amplifier assembly.

Figure 3-7: Rear View of HX Series Digital Driver/Amplifier

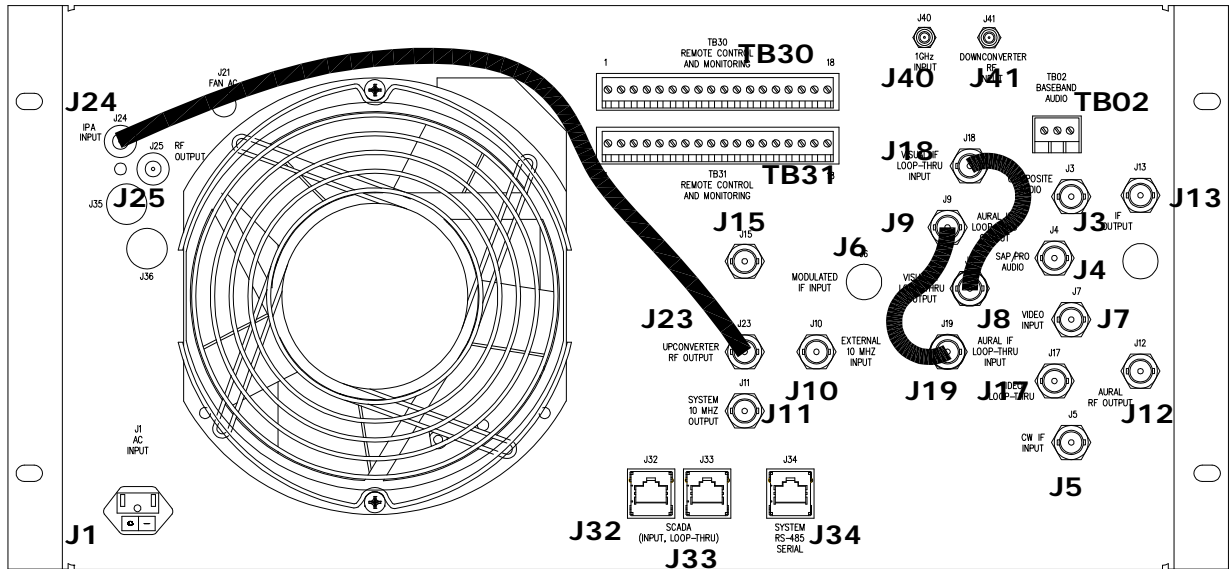

Table 3-2: Rear Chassis Connections for the HX Series Digital Transmitter w/Axciter

Port	Type	Function	Impedance
J1	IEC	AC Input	N/A
TB02	Term	NOT USED Base Band Audio Input	600Ω
J3	BNC	NOT USED Composite Audio Input	75Ω
J4	BNC	NOT USED SAP/PRO Audio Input	50Ω
J5	BNC	NOT USED CW IF Input	50Ω
J6	BNC	NOT USED Modulated IF Input (From Axciter)	50Ω
J7	BNC	NOT USED Video Input (Isolated)	75Ω
J8	BNC	NOT USED Visual IF Loop-Thru Output	50Ω
J9	BNC	NOT USED Modulator Aural IF Output	50Ω
J10	BNC	External 10 MHz Reference Input (From Axciter)	50Ω
J11	BNC	NOT USED System 10 MHz Reference Output	50Ω
J12	BNC	NOT USED MPEG Input to DM8	50Ω
J13	BNC	Downconverter IF Output (To Axciter)	50Ω
J14	BNC	NOT USED RF Spare 2	50Ω
J15	BNC	Digital IF Input (From Axciter)	50Ω
J17	BNC	NOT USED Video Loop-Thru (Isolated)	75Ω
J18	BNC	NOT USED Visual IF Loop-Thru Input	50Ω
J19	BNC	NOT USED Aural IF Loop-Thru Input	50Ω
J23	BNC	Upconverter RF Output (Jumpered to J24)	50Ω
J24	SMA	Power Amplifier RF Input (Jumpered to J23)	50Ω
J25	SMA	Power Amplifier RF Output	50Ω
J35	BNC	NOT USED Power Amplifier Aural RF Input	50Ω
J36	N	NOT USED Power Amplifier Aural RF Output	50Ω
J32	RJ-45	SCADA (Input/Loop-Thru)	CAT5
J33	RJ-45	SCADA (Input/Loop-Thru)	CAT5

Port	Type	Function	Impedance
J34	RJ-45	System RS-485 Serial	CAT5
J40	BNC	1 GHz Input (From Axciter)	500
J41	SMA	Downconverter RF Input (From Relay)	500
TB30	Termination	Remote Control & Monitoring	N/A
TB31	Termination	Remote Control & Monitoring	N/A

NOTE: Bolded Items are used in this configuration.

3.6 Initial Turn On

Once the transmitter has been installed and all connections have been made, the process of turning on the equipment can begin. First verify that AC power is present and connected to the transmitter. Verify all cables are properly connected and are the correct type. Once these checks are completed, the unit is ready to be turned on following the procedures below.

Turn on the main AC power source that supplies the AC to the transmitter. Switch On CB1 the 15 Amp circuit breaker located at the bottom of the control cabinet. If the Driver/Amplifier Chassis Assembly does not turn On, check that the AC breaker located on the rear of the Driver/Amplifier Chassis Assembly located under the AC input plug is On. Switch On CB1 and CB2 the two 30 Amp circuit breakers located at the bottom of each amplifier cabinet.

Caution AC is now applied to the entire transmitter.

3.6.1 Driver/Amplifier Front Panel LED Indicators

Monitor the LCD display located on the front of the control/monitoring module as you proceed through this section. When the transmitter is in the operate mode, the STB menu appears. When in the standby mode, the OPR menu appears. Press the NXT key after each menu to continue through the sequence.

3.6.1.1 Upconverter Module LEDs on Front Panel

Status Indicators:

PLL: This illuminates Green when the phase lock loop circuit is closed, Red if unlocked.

STATUS: This illuminates Green if no faults, Red when a fault has occurred in the upconverter.

AGC: This illuminates Green when in Auto, Amber when in Manual.

3.6.1.2 Controller Module LEDs on Front Panel

Status Indicators:

OPERATE: This illuminates Green when transmitter is in operate.

FAULT: This illuminates Red when a fault has occurred in the transmitter.

DC OK: This illuminates Green when the DC outputs that connect to the modules in the driver/amplifier assembly are present.

3.6.1.3 Power Amplifier Module LEDs on Front Panel

Status Indicators:

ENABLED: This illuminates Green when the PA is in operate.

DC OK: This illuminates Green when the DC inputs to the PA module are present.

TEMP: This illuminates Green when the temperature of the heatsink in the PA is below 78°C.

MOD OK: This illuminates Green when the PA module is operating and has no faults, Red if there is a fault.

If the Module OK LED is Red and blinking a fault is present. The meaning of the blinking LED is as follows.

- 1 Blink:** Indicates Amplifier Current Fault.
- 2 Blinks:** Indicate Temperature Fault.
- 3 Blinks:** Indicate +32V Power Supply Over Voltage Fault.
- 4 Blinks:** Indicate +32V Power Supply Under Voltage Fault.
- 5 Blinks:** Indicate Reflected Power Fault.
- 6 Blinks:** Indicate +12V or -12V Power Supply Fault

3.6.2 Front Panel Screens for the Transmitter using the Driver/ Amplifier Chassis Display

A 4 x 20 display located on the front of the Control & Monitoring/Power Supply Module is used in the HX Series transmitter for control of the operation and display of the operating parameters of the transmitter. Below are the display screens for the system. The ↑ and ↓ characters are special characters used to navigate up or down through the menu screens. Display text flashes on discrete fault conditions for all screens that display a fault condition. When the transmitter is in the operate mode, the STB menu appears. When the transmitter is in the standby mode, the OPR menu appears.

Display Menu Screens for the HX Series Driver/Amplifier

Table 3-3: Menu 01 - Splash Screen #1



This is the first of the two transmitter splash screens that is shown for the first few seconds after reset or after pushing the SPL button on the Main Screen. Will automatically switch to the second splash screen.

Table 3-4: Menu 02- Splash Screen #2



This is the second of the two transmitter splash screens. Will automatically switch to the Main Screen. The Model Number, Code Version Number and Firmware Number for your system are displayed on this screen. Make note of these two numbers when conferring with Axcera on software problems.

Table 3-5: Menu 10 - Main Screen:



This is the default main screen of the transmitter. When the transmitter is in Standby, the 'OPR' characters appear in the lower right. By pushing the right most button located under to display the operator will place the Transmitter in Operate. When the transmitter is in Operate the 'SBY' characters are displayed and the "OFF" is replaced

with 'ON' and the forward power values are displayed. An operator can change the transmitter from STANDBY to OPERATE by pressing the right most button on the front panel display. Pushing the SPL button will display the two splash screens.

If the ↓ key is activated the display changes to Menu 11, the System Error List Access Screen. If the ↑ key is activated the display changes to Menu 13, the Transmitter Configurations Access Screen.

Table 3-6: Menu 11 - Error List Access Screen



This screen of the transmitter shows the current number of errors, displayed in upper, right of screen (0), and provides operator access to view Menu 20, the error list screens, by pushing the ENT button. When ENT is pushed, Menu 20, the Error List Display Screen is displayed. If the ↓ key is pushed the display changes to Menu 12, Table 3-7, the Transmitter Device Data Access Screen. If the ↑ key is activated the display returns to Menu 10, the Main Screen.

Table 3-7: Menu 12 - Transmitter Device Data Access Screen



This screen of the transmitter allows access to various parameters of the transmitter system. This is the entry point to Menu 30, the System Details Screens, by pausing the ENT button. When the ENT button is pushed, Menu 30 is accessed. Go to Menu 30, Table 3-12 for set up details. Before pushing the ENT button: if the ↓ key is activated the display changes to Menu 13, Transmitter Configurations Access Screen. If the ↑ key is activated the display returns to Menu 11, the Error List Access Screen.

Table 3-8: Menu 13 - Transmitter Configuration Access Screen



This screen of the transmitter allows access to various software settings of the transmitter system. If ENT is pushed, go to Menu 40, Table 3-13, the access to transmitter configuration and set up. Before pushing the ENT button: if the ↓ key is activated the display returns to Menu 10, Main Screen. If the ↑ key is activated the display returns to Menu 12, the Transmitter Device Data Access Screen.

Table 3-9: Menu 20 - Error List Display Screen

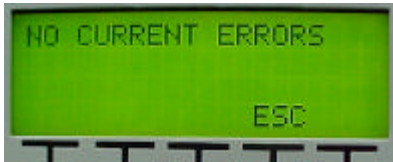

This screen of the transmitter allows access to the system faults screens. Fault logging is stored in non-volatile memory. The transmitter's operating state can not be changed in this screen. The 'CLR' switch is used to clear previously detected faults that are no longer active. The ↑ key and ↓ key allow an operator to scroll through the list of errors that have occurred. The ESC button is used to leave this screen and return to Menu 11, Table 3-6, the Error List Access Screen. **NOTE:** Shown is example of a typical screen.

Menu 30 is entered by selecting ENT at Menu 12, Table 3-7.

Table 3-10: Menu 30 - Transmitter Device Details Screen

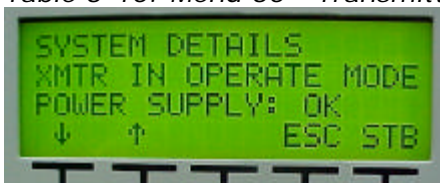

This screen allows access to the transmitter parameters of installed devices. The system is configured to know which devices are present. Current values for all installed devices are shown. If a module is not installed, only a "MODULE NOT PRESENT" message will be displayed. The first screen displayed is Menu 30-1, Table 3-11, the System Details Screen.

Table 3-11: Menu 30-1 – System Details Screen

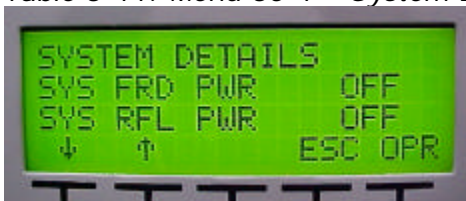

The ↓ and ↑ arrows allow you to scroll through the different parameters of each device as shown in **Table 3-12**. Each System Component is a different screen. The proper modules will be programmed for your system. The External Amplifier Modules are displayed in each amplifier cabinet. Examples of External Amplifier Modules displays are: (AMPLIFIER CABINET 1 MODULE 1) and (AMPLIFIER CABINET 2 MODULE 4).

Table 3-12: Transmitter Device Parameters Detail Screens

System Component	Parameter	Normal	Faulted (Blinking)
Axciter Details	D/C PIN ATTEN VOLTAGE	~ .6V	N/A
	OVERDRIVE FAULT	~ 1.6V	N/A
	AGC MODE	AUTOMATIC	N/A
	ADAPTIVE EQUALIZATION STATUS	RUNNING	N/A
	MEASURED SIGNAL TO NOISE	~ 32.6dB	N/A
	PLL STATUS	LOCKED	N/A
	SMTE310 INPUT STATUS	OK	N/A
	DEMOD FUNCTION STATUS	OK	N/A
	FX VERSION	~ 1.013	N/A
	NB VERSION	~ 0.029	N/A
Upconverter Details	D/C PIN ATTEN VOLTAGE		N/A
	U/C PIN ATTEN VOLTAGE	~ 1.6V	N/A
	AFC 1 LEVEL	~ 0.06V	N/A
	INPUT STATUS	ON	N/A
	OUTPUT STATUS	ON	N/A
	AGC 1 LEVEL	~ 0.32V	N/A
	AGC 2 LEVEL	~ 0.00V	N/A
	PLL	XXXMHz	N/A
	PLL STATUS	~ OK	FAULT
	OVERDRIVE LEVEL STATUS	OK	FAULT
	CODE VERSION	1.6g or higher	N/A
	EPLD	1.4 or higher	N/A
System Control Details	SUPPLY ENABLED FOR	xxx HOURS	N/A
Driver PA Details	POWER SUPPLY STATE, 28V	28 VDC	N/A
	±12V SUPPLY	Enabled or Disabled	FAULT
	FORWARD POWER	xxx%	N/A
	REFL POWER	xxx%	N/A
	AMP 1 CURRENT	xx.xA	N/A
	AMP 2 CURRENT	xx.xA	N/A
	TEMPERATURE	xxC	N/A
	CODE VERSION	x.x	N/A
	PA HAS OPERATED FOR	x.x HRS	N/A
Amplifier Cabinet 1 Details	POWER SUPPLY 1 OFF and OK	ON and OK	FAULT
	POWER SUPPLY 2 OFF and OK	ON and OK	FAULT
	FORWARD POWER	xxx%	N/A
	REFLECTED POWER	xxx%	N/A
	AVG POWER	xxx%	N/A
	AGC LEVEL	0 - 5.00 V	N/A
	IN - INLET AIR TEMP	xxC	N/A
	OUT - EXHAUST AIR TEMP	xxC	N/A
	RL1-4 FLT	xxC	N/A
	RL5-8 FLT	xxC	N/A
	COOLING BLOWER	ON or OFF	N/A
CODE VERSION	x.x	N/A	

System Component	Parameter	Normal	Faulted (Blinking)
Amplifier Cabinet 1 Module 1 Details	RF OUTPUT	Enabled or Disabled	N/A
	POWER SUPPLY	x.xV	N/A
	DRIVER FORWARD POWER	xxx%	N/A
	FINAL FORWARD POWER	xxx%	N/A
	FINAL REFLECTED POWER	xxx%	N/A
	CURRENT 1	xx.xA	N/A
	CURRENT 2	xx.xA	N/A
	CURRENT 3	xx.xA	N/A
	CURRENT 4	xx.xA	N/A
	CURRENT 5	xx.xA	N/A
	CURRENT 6	xx.xA	N/A
	CURRENT 7	xx.xA	N/A
	FLANGE TEMP	xxC	N/A
HEATSINK TEMP	xxC	N/A	
CODE VERSION	x.x	N/A	

NOTE: Pushing the ↓ Down Arrow will show on screen the parameters for the rest of the modules in Cabinet 1, and then the other cabinets in the system, if present.

Pushing the ↓ Down Arrow, after scrolling through all of the detail screens, will put you back to Menu 30, Table 3-10. Push the ESC button to exit the Transmitter Device Parameter Screens to Menu 12, Table 3-7, the Transmitter Device Parameter Access Screen.

Menu 40 (Table 3-13) is entered by selecting ENT at Menu 13.

Table 3-13: Menu 40 - Authorized Personnel Screen

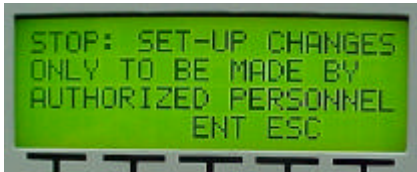

This screen of the transmitter notifies an operator that they are only to proceed if they are authorized to make changes to the transmitter's operation. Changes made within the following set-up screens can affect the transmitters output power level, output frequency, and the general behavior of the transmitter. Please do not make changes within the transmitter's set-up screens unless you are familiar with the operation of the transmitter. This screen is implemented in transmitter software version 1.4 and above.

Pressing ENT will put you into the Transmitter Set Up Screens for Menu 40.

A safeguard is added to the Set Up Menus in software version 2.5 and above. If a change is made to a screen within the Set Up Menus, when you go to the next menu, a new screen asks if you accept the change or want to return to the previous menu to reconsider the changes made.

To accept the changes, the two buttons located under ACCEPT must be pushed simultaneously.

To return to the previous Menu to make corrections, the two buttons located under the RETURN must be pushed simultaneously.

Upon returning to the previous Menu the correct input must be entered and the above procedure repeated, this time accepting the changes

Accept or Return to previous Menu Screen



Pushing these two buttons Simultaneously will accept the change.

Pushing these two buttons Simultaneously will return you to the previous Menu.

Typical Set Up Screens are shown in Table 3-14 Menu 40-1 through Table 3-24 Menu 40-19 that follow.

Table 3-14: Menu 40-1 - Transmitter Set-up: Power Control Screen



This screen of the transmitter is the first of several that allows access to transmitter set-up parameters. When + is selected, the Power will increase. When - is selected, the Power will decrease.

Table 3-15: Menu 40-3 - Transmitter Set-up: Model Select Screen



This screen is used to specify which components are expected to be part of the system. By specifying the model number, the transmitter control firmware knows which components should be installed and it will be able to display faults for components that are not properly responding to system commands.

Table 3-16: Menu 40-4 - Transmitter Set-up: Upconverter Channel Select Screen



The choices of this screen are to the standard UHF / VHF channels. The + and – buttons change the desired channel of the transmitter. The PLL frequency is set for custom Offsets within the upconverter frequency. Any change to the channel is immediately set to the Upconverter Frequency Synthesizer PLL circuit.

Table 3-17: Menu 40-5 - Transmitter Set-up: Serial Address Screen



This screen allows the user to set the serial address of the transmitter. The default address is 5. This value and all other set-up parameters are stored in non-volatile memory.

Table 3-18: Menu 40-6 - Transmitter Set-up: System Forward Power Calibration



This screen is used to adjust the calibration of the system's forward power. A symbol placed under the '6' character is used to show major changes in the calibration value. When the calibration value is at full value, the character will be full black. As the value decreases, the character pixels are gradually turned off. The calibration value is a value between 0 and 255 but the calibration value symbol only has 40 pixels. Therefore small changes in actual calibration value may not affect the symbol's appearance.

Table 3-19: Menu 40-9 - Transmitter Set-up: System Reflected Power Calibration



This screen is used to adjust the calibration of the system's reflected power. Again a calibration value symbol is used for this screen as on the previous screens.

Table 3-20: Menu 40-13 - Transmitter Set-up: Minimum Forward Power Fault
Threshold Screen

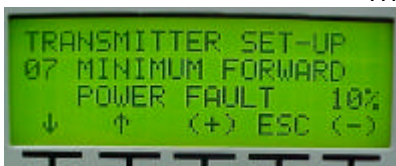

This screen is used to set the minimum forward power fault threshold. When the transmitter is operating, it must operate above this value otherwise the system will shut down with fault for 5 minutes. If after five minutes the fault is not fixed, the transmitter will enable, measure the power and if less than this value it will again shut down for five minutes.

Table 3-21: Menu 40-14 - Transmitter Set-up: Maximum Reflected Power Fault Threshold



This screen is used to set the maximum reflected power fault threshold. When the transmitter is operating, it must not operate above this value otherwise the system will slowly begin to reduce the forward output power. If the system's reflected output power exceeds the maximum reflected power threshold by five percent or more, the transmitter will shut down with fault for 5 minutes. If after five minutes the fault is not fixed, the transmitter will enable, measure power and if above this value plus five percent it will again shut down for five minutes. If the system's reflected output power exceeds the maximum reflected power threshold due to some condition like the formation of ice on an antenna, the transmitter reduces visual forward power to a level where the reflected power is less than this threshold. The transmitter will automatically increase its output power to normal operation when the cause of higher than normal reflected power is corrected.

Table 3-22: Menu 40-18 - Transmitter Set-up: Inner Loop Gain Control



This screen is used to set up the Inner Loop Gain of the driver/amplifier assembly. This feature is implemented in transmitter software version 2.0 and above

Table 3-23: Menu 40-19 - Transmitter Set-up: Amplifier Module Control

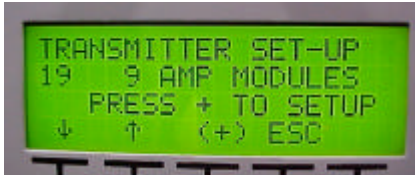

This screen is used to monitor the external amplifier modules in the amplifier cabinets.

Table 3-24: Menu 40-19 - Transmitter Set-up: Remote Commands Control



This screen is used to allow or deny the use of remote control commands. When disabled, remote commands are not used. Remote commands are commands received either through the rear terminal blocks or through serial messages.

Push the ESC button to exit the Transmitter Set Up Screens to Menu 13, Table 3-8, the Transmitter Configuration Access Screen.

This completes the description of the menu screens for the HX Series driver/amplifier chassis assembly.

3.6.3 Front Panel Touch Screens for the UHF Transmitter

The touch screen at the top of the Control/Exciter Cabinet gives the operator access the same information and control of the transmitter as just described in the proceeding section by the screens on the Controller/Power Supply module in the Driver/Amplifier Chassis Assembly. Examples of the typical screens are

shown on the following pages. Your screens may differ from these examples.

By using the cursor and the mouse or by touching the screen, first, the selected control or the amplifier cabinet screen will be highlighted. Then, by selecting a tray or module, that tray or module will highlight and the operating parameters for that tray or module will be displayed.

Figure 3-8 Control/Exciter Cabinet System Controller Screen



Shown above is the control screen for the Control/Exciter Cabinet of the HX Series Transmitter. The cabinet is selected in the **upper left quadrant**. In the above display the Exciter/Control cabinet is selected, it is highlighted. The **lower left quadrant** displays the selected module and displays the parameters for that module. In the above display the System Control Module is selected, it is highlighted, and the operating parameters for the System Control Module are displayed on the right. The **upper right quadrant** contains the Transmitter System Control, which, by touching the Operate or Standby button, places the transmitter in that mode. The Transmitter System parameters, % Visual Forward Power, % Aural Forward Power and % Reflected Power are also displayed in the upper right quadrant.

Figure 3-9 Amplifier Cabinet and Transmitter Configuration Screen

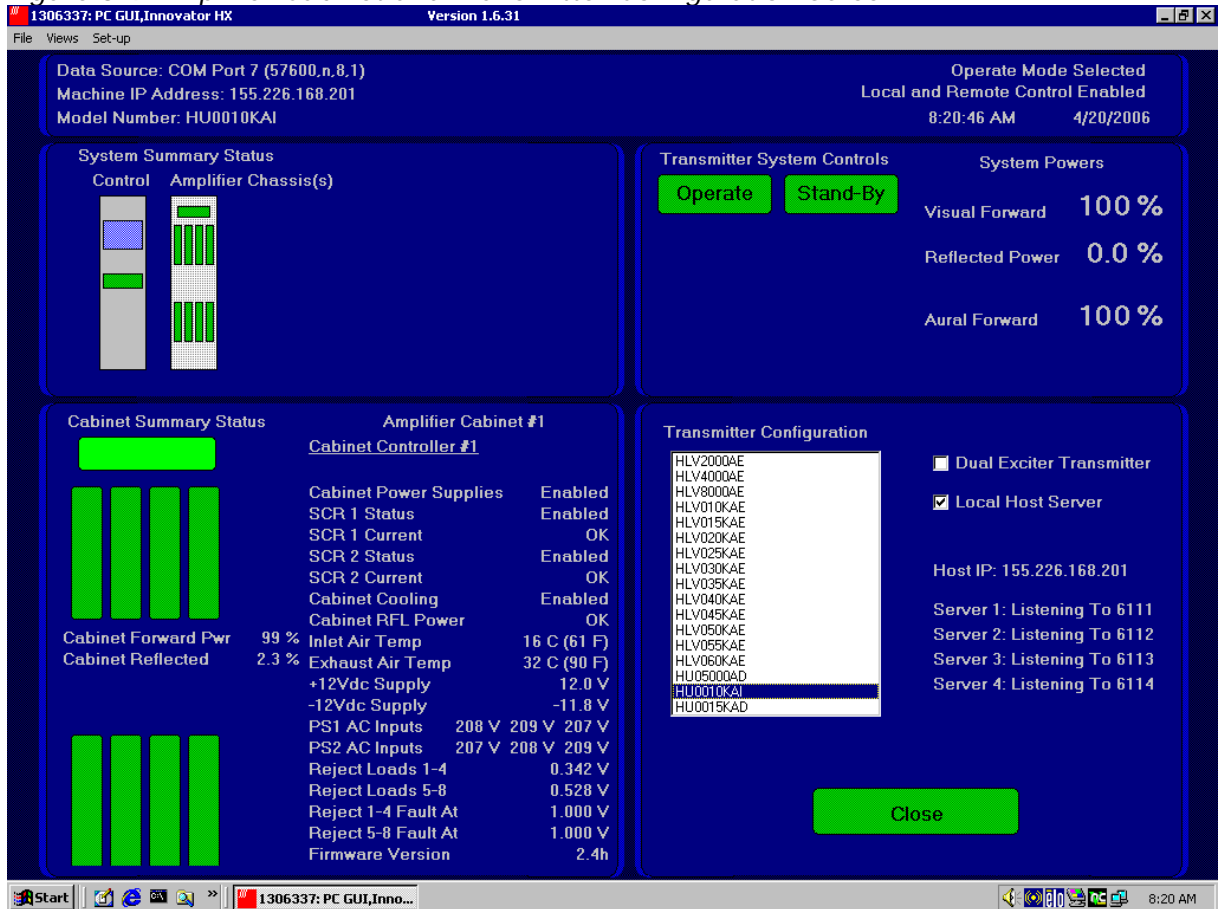

Shown in the above figure is the control screen for the Amplifier Cabinet of the HX Series Transmitter. The cabinet is selected in the **upper left quadrant**. In the above display, the Amplifier Cabinet is selected. The **lower left quadrant** displays the selected module and displays the parameters for that module. In the above display, the Cabinet Controller #1 is selected and the operating parameters for the cabinet is displayed on the right. The **upper right quadrant** contains the Transmitter System Controls, which places the transmitter in Operate or Standby. The Transmitter System parameters are also displayed in the upper right quadrant.

The above screen is also the Transmitter Configuration Screen in the **Lower Right Quadrant** that displays the Transmitter Model number, which will be highlighted, in this case HU0010KAI. This screen shows a local host server IP address of 155.226.168.201. If the Remote Data Client is selected, by removing the check in the Local Host Server box, the application attempts to connect to an On-Site Data Server at the indicated IP address. When a remote client is serviced, the server application indicates the client's address at the specific port that is being used.

Figure 3-10 Amplifier Cabinet Screen w/System Error List

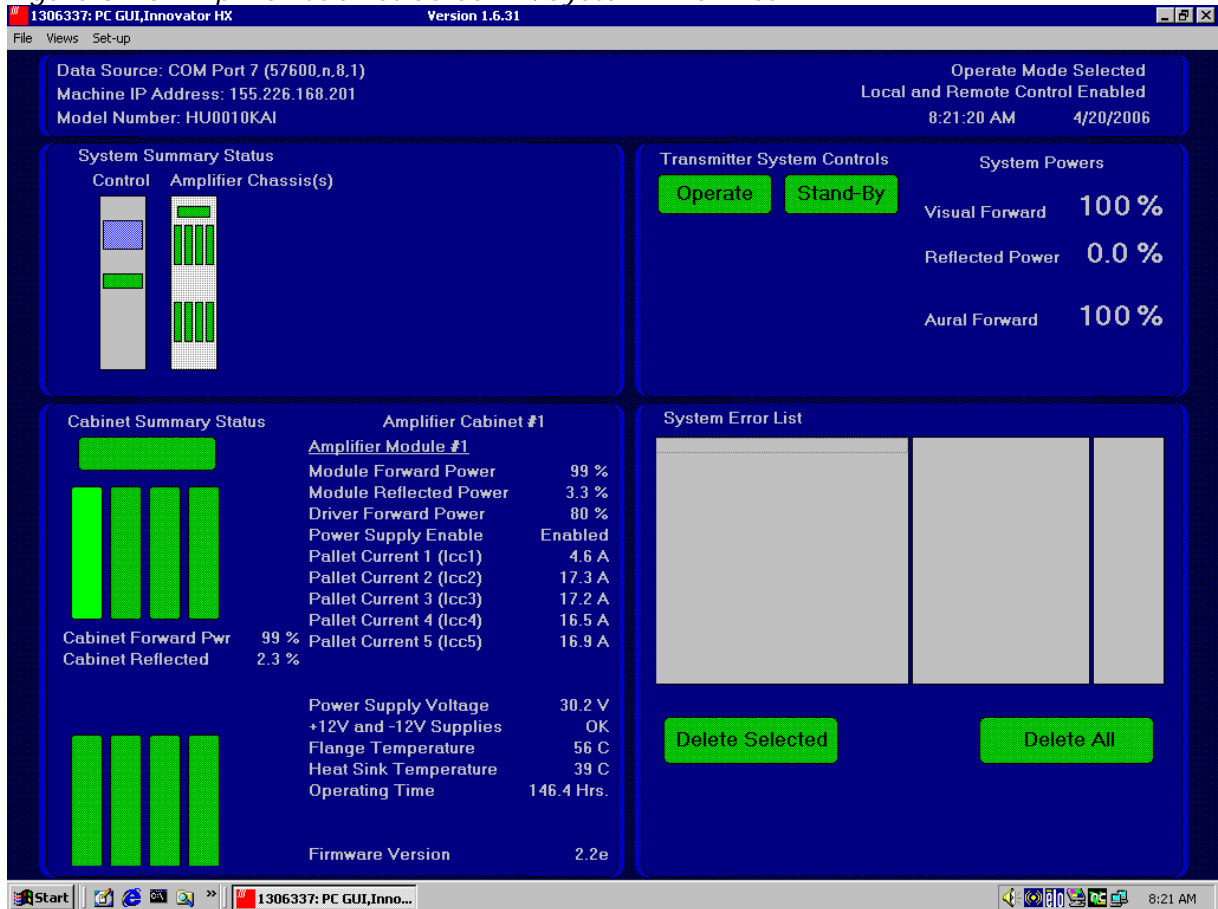

The above screen is the Amplifier Cabinet control screen. The desired amplifier cabinet is selected in the **upper left quadrant**, it will highlight. In the above display, Amplifier Cabinet #1 is selected. The **lower left quadrant** displays the selected module and displays the parameters for that module. In the above display, Amplifier Module #1 is selected and the operating parameters for that module is displayed on the right. The **upper right quadrant** contains the Transmitter System Control, which places the transmitter in Operate or Standby. The Transmitter System parameters are also displayed in upper right quadrant. The **Lower Right Quadrant** displays the Transmitter System Error List. If an error occurs, it will be listed in this area.

Figure 3-11 Control Cabinet Screen w/System Error List



In the above screen, the four quadrants are as described in the previous figures. On this screen, in the **Lower Right Quadrant**, is displayed the Transmitter System Error List. Listed are three separate errors with the dates and times the errors occurred. Also displayed is the status of the error either **Active**, still occurring, or **Cleared**, an error occurred but has reset itself. The two cleared faults, Modulator PLL Not Locked, indicate that the phase lock loop circuit maintaining the lock between the 4.5 MHz and the 45.75 MHz was not closed.

The **Active** fault, IF Processor Not Installed, which indicates the IF Processor is not making contact or missing. With an active fault, a visual Red indication of the fault will be displayed in the Upper Left and Lower left Quadrants. In the above screen, upper left quadrant, the control cabinet is selected and the Driver is Red, indicating a fault within the Driver Assembly. The lower left quadrant indicates the Cabinet Summary Status. In this case, the Driver #1 is Red, indicating a fault in Driver #1. Within the Driver Assembly, the IF Processor Module is Red, indicating the fault is within the IF Processor.

By highlighting the fault in the Transmitter System Error List, that fault can be deleted by touching the Delete Selected button, if that fault is cleared. All of the cleared faults displayed may be deleted by touching the Delete All button.

Figure 3-12 Serial Port Configuration Screen

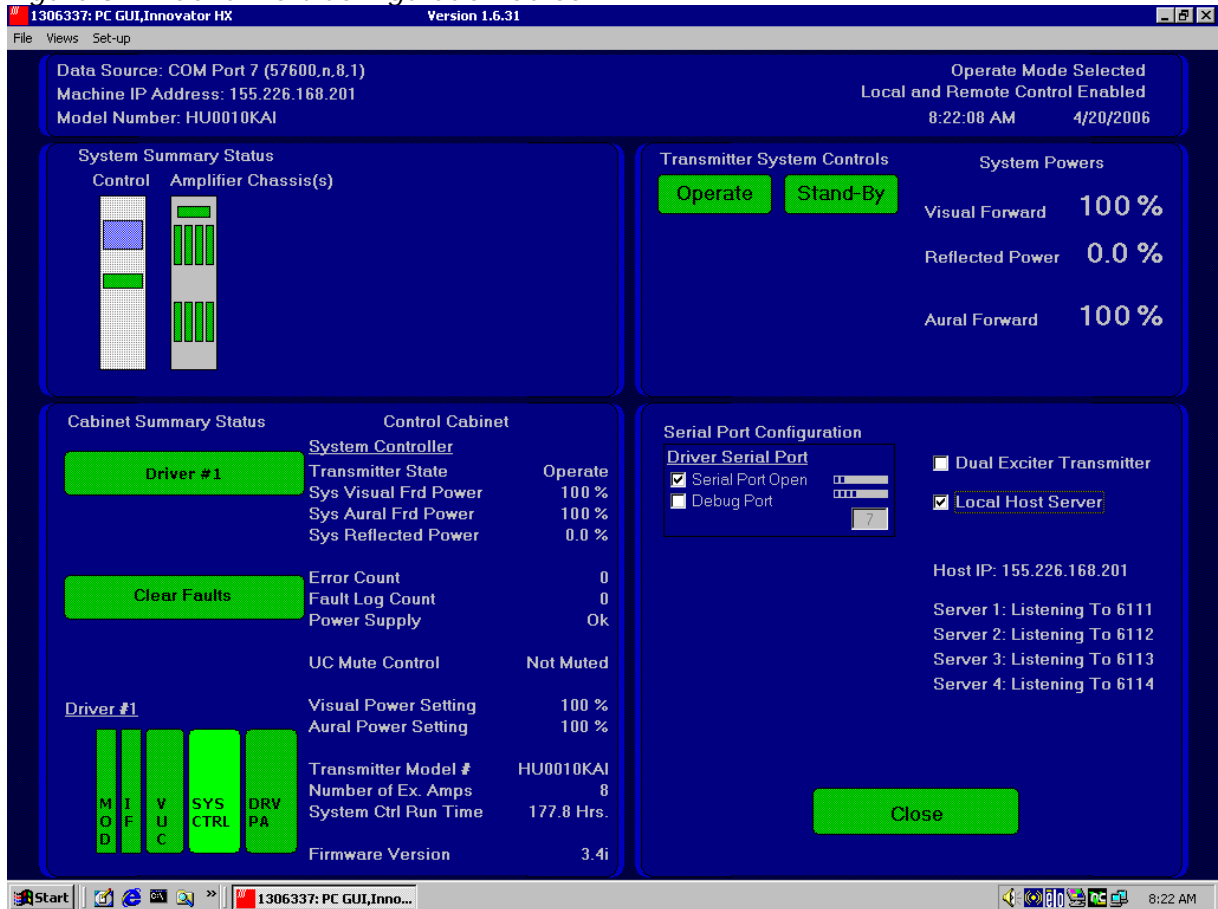

The above screen is the Serial Port Configuration Screen. This screen shows a local host at the TCP/IP Address 155.226.168.201 and no remote clients connected at ports 6111 thru 6114. This screen displays, in the **upper left quadrant**, the cabinets and which cabinet is selected, in this case the Control Cabinet. In the **lower left quadrant**, the selected cabinet parameters are displayed on the left between the module representations. Also in the lower left quadrant, on the right is displayed the parameters of the module selected, which is highlighted on the left, in this case the System Controller. The **upper right quadrant** contains the Transmitter System Control, which places the transmitter in Operate or Standby. The Transmitter System parameters are also displayed in upper right quadrant. The **lower right quadrant** is used to configure and monitor the site serial port status. The settings shown above are typical of a system. An operator can visually determine if data messages are being sent and if the device is responding. If a specific port has debugging enabled, the box is selected. When the GUI application is operating at the transmitter site, the Local Host Server Box must be selected. As an on-site data server, the serial ports are automatically enabled, and the system provides data for up to four remote applications. If the Local Host Server Box is not selected, the application attempts to connect to an On-Site Data Server at the indicated IP address. When a remote client is serviced, the server application indicates the client's address at the specific port that is being used.

3.6.4 Operation Procedure

If necessary, connect to the transmitter to the antenna. Check that the RF output is 100% and if needed adjust the ALC Gain of the Axciter to attain 100% RF Output. The power raise/lower settings, in the menus, are only to be used for temporary reductions or increases in power.

The power set-back values do not directly correspond to the output power of the transmitter.

This completes the Installation, Set Up and Turn On of the Transmitter.

If a problem occurred during the setup and operation procedures, refer to Chapter 5, Detailed Alignment Procedures, of this manual for more information.

Chapter 4 Circuit Descriptions

4.1 (R1) Control/Exciter Cabinet Assembly (1306879; Appendix C)

The Exciter/Driver System Control Cabinet contains a computer with a touch screen, keyboard and mouse and a UPS power supply. There are also an HX Series Driver/Amplifier Assembly and an Exciter Modulator system

NOTE: Information on the Exciter Modulator Tray, the Upconverter and Downconverter modules can be found in the separate Exciter Instruction Manual provided.

4.1.1 (A4) Dual Peak Detector Board (1159965; Appendix C)

The function of the dual peak detector board is to detect forward and reflected output power samples and generate output voltages that are proportional to the power levels of the sampled signals for use by the control monitoring assembly in the exciter.

There are two identical signal paths on the board: one for forward power and one for reflected power. A sample of forward output power, from the external DTV mask filter, enters the board at the SMA jack J1. Resistors R1 and R2 form an input impedance-matching network of 50Ω. The forward power signal is detected by CR1, R7, R25, C1, and C7. For digital operation the jumpers, W1 on J6 and W3 on J8, are both between pins 1 & 2. The detected output is buffered by the operational amplifier U1C before it is split. One part is connected to the forward uncalibrated power output jack J4. The other split output is connected to forward power adjust pot R9, which adjusts the gain of U1D. The output of

U1D is split with one part connected to J3-4 Forward Power Metering Output #1. The other output of U1D is connected to J3-6 Forward Power Metering Output #2.

A sample of reflected output power, from the external DTV mask filter, enters the board at the SMA jack J2. Resistors R3 and R4 form an input impedance-matching network of 50Ω. The reflected power signal is detected by CR2, R26, R8, C3, and C8. For digital operation the jumper W2 on J7 is between pins 1 & 2. The detected output is buffered by the operational amplifier U1B before it is split. One part is connected to the reflected uncalibrated power output jack J5. The other split output is connected to reflected power adjust pot R10, which adjusts the gain of U1A. The output of U1A is split with one part connected to J3-9 Reflected Power Metering Output #3. The other output of U1A is connected to J3-11 Reflected Power Metering Output #4.

The +12 VDC needed for the operation of U1 on the board enters the board at J3-2 and is connected through a filter and isolation circuit consisting of C5, C9 and L3 before it is connected to U1. The -12 VDC needed for the operation of U1 on the board enters the board at J3-8 and is connected through a filter and isolation circuit consisting of C6, C12 and L6 before it is connected to U1.

4.1.2 (A46) Serial Loop-Thru Board (1307811; Appendix C)

The function of the serial loop-thru board is to provide an extra serial loop thru that can connect to the driver/amplifier assembly or the Exciter modulator.

4.2 (A3) Driver/Amplifier Chassis Assembly (1305801, 110 VAC or 1305555, 220 VAC; Appendix D)

This assembly is mounted in Rack 1 the Control/Exciter Cabinet. The assembly contains, as mounted in the assembly from left to right, (A1) the Downconverter Module, (A5) the Upconverter Module, (A4) the System Controller/Power Supply Module, and (A6) the Power Amplifier/Driver Module.

NOTE: Information on the Axciter Upconverter module and Downconverter module can be found in the separate Axciter Instruction Manual provided.

4.2.1 (A4) Control Monitoring/Power Supply Module (1301936, 110 VAC, 1303229, 220 VAC; Appendix D)

The Control Monitoring/Power Supply Module Assembly contains (A1) a Power Protection Board (1302837), (A2) a 600 Watt Switching Power Supply, (A3) a Control Board (1302021), (A4) a Switch Board (1527-1406) and (A5) a LCD Display.

AC Input to Innovator HX Driver/Amplifier Chassis Assembly

The AC input to the Driver/Amplifier Chassis Assembly is connected from J1, part of a fused entry module, located on the rear of the chassis assembly to J50 on the Control Monitoring/Power Supply Module. There are two possible modules that can be part of your system, 1301936 for 110 VAC or 1303229 for 220 VAC operation. J50-10 is line #1 input, J50-8 is earth ground and J50-9 is line #2 input. The input AC connects to J1 on the Power Protection Board where it is fuse protected and connected back to J50, at J50-11 AC Line #1 and J50-12 AC Line #2, for distribution to the cooling Fan.

4.2.1.1 (A1) Power Protection Board (1302837; Appendix D)

The input AC connects through J1 to two 10 Amp AC fuses F1 and F2. The AC line #1 input connects from J1-1 to the F1 fuse. The AC line #1 input after the F1 fuse is split with one line connected back to Jack J1 Pin 4, which becomes the AC Line #1 to the Fan. The other line of the split connects to J4. The AC line #2 input connects from J1-3 to the F2 fuse. The AC line #2 input after the F2 fuse is split with one line connected back to Jack J1 at Pin 5, which becomes the AC Line #2 to the Fan. The other line of the split connects to J2. J1-2 is the earth ground input for the AC and connects to J3.

Three 150 VAC, for 115 VAC input, or three 275 VAC, for 230 VAC input, MOVs are connected to the input AC for protection. One connects from each AC line to ground and one connects across the two lines. VR1 connects from J4 to J2, VR2 connects from J4 to J3 and VR3 connects from J2 to J3.

4.2.1.1.1 +12 VDC Circuits

+12 VDC from the Switching Power Supply Assembly connects to J6 on the board. The +12 VDC is divided into four separate circuits each with a 3 amp self resetting fuse, PS3, PS4, PS5 and PS6.

The polyswitch resettable fuses may open on a current as low as 2.43 Amps at 50°C, 3 Amps at 25°C or 3.3 Amps at 0°C. They definitely will open when the current is 4.86 Amps at 50°C, 6 Amps at 25°C or 6.6 Amps at 0°C.

PS3 protects the +12 VDC 2 Amp circuits for the System Controller, the Amplifier Controller and the Spare Slot through J62 pins 7, 8, 9 and 10. If this circuit is operational, the Green LED DS3, mounted on the board, will be lit.

PS4 protects the +12 VDC 2 Amp circuits for the Modulator and the IF Processor through J62 pins 13, 14, 15 and 16. If

this circuit is operational, the Green LED DS4, mounted on the board, will be lit

PS5 protects the +12 VDC 2 Amp circuits for the Upconverter through J62 pins 17, 18, 19 and 20. If this circuit is operational, the Green LED DS5, mounted on the board, will be lit

PS6 protects the +12 VDC 2 Amp circuits for the Remote through J63 pins 17, 18, 19 and 20. If this circuit is operational, the Green LED DS6, mounted on the board, will be lit

4.2.1.1.2 -12 VDC Circuits

-12 VDC from the Switching Power Supply Assembly connects to J5 on the board. The -12 VDC is divided into two separate circuits each with a 3 amp self resetting fuse, PS1 and PS2.

PS1 protects the -12 VDC 2 Amp circuits for the System through J63 pins 1, 2, 3 and 4. If this circuit is operational, the Green LED DS1, mounted on the board, will be lit

PS2 protects the -12 VDC 2 Amp circuits for the Remote through J62 pins 1, 2, 3 and 4. If this circuit is operational, the Green LED DS2, mounted on the board, will be lit

The connections from J62 and J63 of the Power Protection Board are wired to J62 and J63 on the Control Board.

4.2.1.2 (A3) Control Board (1302021; Appendix D)

The control monitoring functions and front panel operator interfaces are found on the Control Board. Front panel operator interfaces are brought to the control board using a 26 position conductor ribbon cable that plugs into J60. The control board controls and monitors the Power Supply and Power Amplifier module through a 16 position connector J61 and two 20 position connectors J62 & J63.

4.2.1.2.1 Schematic Page 1

U1 is an 8 bit RISC microcontroller that is in circuit programmed or programmed using the serial programming port J4 on the board. When the microcontroller, U1, is held in reset, low on pin 20, by either the programming port or the external watchdog IC (U2), a FET Q1 inverts the reset signal to a high that connects to the control lines of U5, an analog switch. The closed contacts of U5 connect the serial programming lines from J4 to U1. LED DS10 will be lit when programming port J4 is used.

U2 is a watchdog IC used to hold the microcontroller in reset, if the supply voltage is less the 4.21 VDC; (1.25 VDC < Pin 4 (IN) < Pin 2 (Vcc). The watchdog momentarily resets the microcontroller, if Pin 6 (ST) is not clocked every second. A manual reset switch S1 is provided but should not be needed.

Diodes DS1 through DS8 are used for display of auto test results. A test board is used to execute self test routines. When the test board is installed, Auto_Test_1 is held low and Auto_Test_2 is allowed to float at 5 VDC. This is the signal to start the auto test routines.

U3 and U4 are used to selectively enable various input and output ICs found on pages 2 & 3 of the schematic.

U1 has two serial ports available. In this application, one port is used to communicate with transmitter system components where U1 is the master of a RS-485 serial bus. The other serial port is used to provide serial data I/O where U1 is not the master of the data port. A dual RS-232 port driver IC and a RS-485 Port driver are also in the second serial data I/O system. The serial ports are wired such that serial data input can come through one of the three serial port channels. Data output is sent out through each of the three serial port channels.

Switch SW1, transmitter operation select, is used to select either transmitter operation or exciter/driver operation. When the contacts of SW1 are closed, transmitter operation is selected and the power monitoring lines of the transmitter's power amplifier are routed to the system power monitoring lines.

4.2.1.2.2 Schematic Page 2

U9 is a non-inverting transceiver IC that provides 2 way asynchronous communication between data busses. The IC is used as an input buffer to allow the microcontroller to monitor various digital input values.

Digital output latch circuits are used to control system devices. Remote output circuits are implemented using open drain FETs, Q13, Q14, Q16, and Q17, with greater than 60 Volt drain to source voltage ratings.

Remote digital inputs are diode protected, using CR6, CR7, CR8 and CR9 with a 1 kΩ pull-up resistor, to +5 VDC. If the remote input voltage is greater than about 2 Volts or floating, the FET is turned on and a logic low is applied to the digital input buffer, U9. If the remote input voltage is less than the turn on threshold of the FET (about 2 VDC), a logic high is applied to the digital input buffer, U9.

Four of the circuits on page two of the schematic, which include Q2, Q9, Q19 and Q21, are auxiliary I/O connections wired for future use. They are wired similar to the remote digital inputs but include a FET, Q5, Q12, Q20 and Q22, for digital output operations. To operate these signals as inputs, the associated output FET must be turned off. The FETs are controlled by U10 and U12, analog input multiplexer ICs.

4.2.1.2.3 Schematic Page 3

U13, U14, U15, U16, U17 and U18 are 3 state non-inverting transceiver ICs that provide 2 way asynchronous communication between data busses. The ICs are used as input buffers to allow the microcontroller to monitor various digital input values. The digital inputs to the ICs utilize a 10 kΩ pull-up resistor. The buffer IC, U18, used for data transfer to the display is wired for read and write control.

Table 4-1: Innovator HX DIP Switch Settings for SW2 located on the Exciter Control Board (1302021) in the Power Supply/Controller Assembly

Switch Position	Function
SW2-1	0 = No Modulator in a translator configuration 1 = Modulator present.
SW2-2	0 = Normal 1 = Aural Upconverter not to be installed
SW2-3	0 = Normal 1 = IP Processor not to be installed
SW2-4	0 = Normal 1 = Modulator not to be installed
SW2-5	0 = Normal 1 = Visual Upconverter not to be installed
SW2-6	0 = Off 1 = On
SW2-7	0 = Off 1 = On
SW2-8	0 = Off 1 = On

NOTES:

1) The System Controller's DIP Switch 2 (lower bank of 8 switches) settings are 01110000 (1-8). 2) These switch positions are factory set for your system and should not be changed.

4.2.1.2.4 Schematic Page 4

U19 and U20 are digitally controlled analog switches that provide samples back to the microprocessor. Each analog input is expected to be between 0 and 5 VDC. If a signal exceeds 5.1 VDC, a 5.1 Volt Zener diode clamps the signals voltage, to prevent damage to the IC. Most signals are calibrated at their source, however two dual serial potentiometers ICs are used to calibrate four signals, System Average Power, System Aural Power (Not Used), System Reflected Power and the

Spare AIN 1. For these four circuits, the input value is divided in half before it is applied to an op-amp. The serial potentiometer is used to adjust the output signal level to between 80 and 120% of the input signal level. Serial data, serial clock and serial pot enables are supplied by the microprocessor to the dual serial potentiometer ICs. J62 and J63 are two 20 position connectors that provide the +12 VDC and -12 VDC power through the Power Protection Board. The ±12 VDC generated by the switching power supply connects to J62 and J63 after being fuse protected on the Power Protection Board.

4.2.1.2.5 Schematic Page 5

There are three dual element, red/green, common cathode LED indicators mounted on the front panel of the sled assembly; DC OK, Operate and Fault.

There are three, the fourth is a spare, identical circuits that drive the front panel mounted LED indicators. The levels on the 1, 2, 3 and 4 LED Control Lines, for both the red and green LEDs, are generated by the IC U11 as controlled by the DATABUS from the microprocessor U1.

Each LED controller circuit consists of an N-Channel MOSFET w/internal diode that controls the base of an N-P-N transistor in an emitter follower configuration. The emitter of the transistor connects the LED.

With the LED control line LOW, the MOSFET is Off, which causes the base of the transistor to increase towards +12 VDC, forward biasing the transistor. With the transistor forward biased, current will flow from ground through the LED, the transistor and the current limiting resistors in the collector to the +12 VDC source. The effected LED will light.

With the LED control line HIGH, the MOSFET is On, which causes the base of the transistor go toward ground potential that reverse biases the transistor. With the transistor reverse biased, no current through the transistor and LED, therefore the effected LED will not light.

A third color, amber, can also be generated by having both transistors conducting, both control lines LOW. The amber color is produced because the current applied to the green element is slightly greater than the red element. This occurs because the current limiting resistors have a smaller ohmage value in the green circuit.

There are four voltage regulators, three for +5 VDC and one for +7 VDC, which are used to power the Control Board. +12 VDC is applied to U25 the +7 VDC regulator that produces the +7 VDC, which is applied to the LEDs mounted on the board. The +7V is also connected to the input of U26 a precision +5.0 Volt regulator. The +5.0 VDC regulator output is used to power the analog circuits and as the microcontroller analog reference voltage. Another two +5 Volt regulator circuits U27, +5V, and U8, +5 Vserial, are used for most other board circuits.

4.2.1.3 (A4) Switch Board (1527-1406; Appendix D)

The switch board provides five front-panel momentary contact switches for user control and interface with the front-panel LCD menu selections. The switches, SW1 to SW5, complete the circuit through connector J1 to connector J2 that connects to J1 on (A5) the 20 Character by 4 line LCD Display. J1 on the switch board is also cabled to the Control Board. When a switch is closed, it connects a logic low to the control board that supplies the information from the selected source to the display. By pushing the button again, a different source is selected. This occurs for each push button. Refer to Chapter 3 Section 3.5.3, for more information on the Display Menu Screens.

4.2.1.4 (A2) Switching Power Supply Assembly

The power supply module contains a switching power supply, an eight position terminal block for distributing the DC voltages, a three position terminal block to which the AC Input connects. Jack J1 connects to the Control Board and supplies DC OK, at J1-4 & 3, and AC OK, at J1-2 & 1, status to the control board. A Power Supply enable connects from the control board to the power supply at V1-6 & 7. The power supply is configured for three output voltages +12V, -12V, at the 8 position terminal block, and a main output power of +32 VDC at J50 pin A (+) and J50 pin B (Rtn). The power supply is power factor corrected to .98 for optimum efficiency and a decrease in energy consumption. For safety purposes all outputs are over voltage and over current protected. This supply accepts input voltages from 85 to 264 volts AC, but the power entry module, for the exciter/amplifier chassis, must be switched to the proper input voltage setting, for the transmitter to operate.

4.2.2 (A4) Driver Power Amplifier Assembly (1306019; Appendix D)

The Power Amplifier Module Assembly contains (A5) an Amplifier Control Board (1304774), (A1) a 1 Watt UHF Amplifier Assembly (1302891), (A3) a RF Module Pallet, 250W (1300116), and a Coupler Board (1227-1316).

The RF input from the external DT2B Upconverter connects through a 10 dB pad, to the IPA RF Input BNC Jack J24 (≈ 0 dBm), located on the rear of the driver/amplifier chassis assembly.

4.2.2.1 (A1) 1-Watt UHF Module Assembly (1302891; Appendix D)

The 1-watt UHF module assembly provides radio frequency interference (RFI) and electromagnetic interference

(EMI) protection, as well as the heatsink, for the 1-watt UHF amplifier board (1302761) that is mounted inside the assembly. The assembly has approximately 17 dB of gain.

The RF input to the assembly connects to SMA Jack J3. The amplified RF output of the assembly is at the SMA Jack J4. Typically, with an input signal of +0 dBm at J1 of the assembly, an output of +17 dBm can be expected at J2.

The +12-VDC bias voltage connects through J5, a RF-bypassed, feed-through capacitor, to the amplifier board. The -12-VDC bias voltage connects through J6, a RF-bypassed, feed-through capacitor, to the amplifier board. E1 on the assembly connects to Chassis Ground.

4.2.2.2 (A1-A1) 1-Watt UHF Amplifier Board (1302761; Appendix D)

The 1-watt UHF amplifier board is mounted in the 1-watt UHF amplifier assembly (1302891) and provides approximately +17 dB of gain.

The UHF signal enters the board at J3, a SMA connector, and is applied to U3 an IC hybrid coupler assembly that splits the input signal into two equal parts. The two amplifier paths are identical using Q4 and Q5, 1-Watt HFETs as the amplifier devices. Each HFET has approximately 14 dB of gain.

The drain voltage needed to operate each HFET is obtained from the +12 VDC line that connects to the board at J5 and is regulated down to +8.25 volts by U4. The gate negative bias voltage is obtained from the -12 VDC line that connects to the board at J6.

The amplified outputs of the HFETs are applied to U2 an IC hybrid coupler assembly that combines the amplified signals into a single output that connects to J4 of the board.

4.2.2.3 (A3) UHF Module Assembly, RF Module Pallet, Philips (1300116; Appendix D)

The UHF Module Assembly, 250-watt module is a broadband amplifier for the frequency range 470 to 860 MHz. The amplifier is capable of delivering an output power of $\approx 70 W_{rms}$. The amplification is approximately 13 dB.

The amplification circuit consists of the parallel connected push-pull amplifier blocks V1 and V2 operating in class AB. In order to match the transistor impedance to the characteristic impedance of the input and output sides, matching networks are placed ahead and behind the amplifier blocks. Transformers Z3 to Z6 serve to balance the input and output signals. The paralleling circuit is achieved with the aid of 3-dB couplers Z1 and Z2.

The working point setting is factory implemented by means of potentiometers R9, R11, and R12 and should not be altered.

4.2.2.4 (A4) Coupler Board Assembly (1227-1316; Appendix D)

The UHF coupler board assembly provides forward and reflected power samples of the output to (A5) the amplifier control board where it connects to the input of the overdrive-protection circuitry.

The RF input to the UHF coupler assembly, from the UHF amplifier Assembly, connects to SMA jack J1. The RF is connected by a stripline track to the SMA type connector RF Output jack J2. A hybrid-coupler circuit picks off a power sample that is connected to SMA type connector jack J3 as the forward power sample. Another power sample is taken from the coupler circuit that is connected to SMA type connector jack J6 as the reflected power sample. Two 500 terminations, used as dissipation loads,

connect to the reject and reflected ports, J5 and J4, of the coupler.

4.2.2.5 (A5) Amplifier Control Board (1304774; Appendix D)

The amplifier control board provides LED fault and enable indications on the front panel of the module and also performs the following functions: overdrive cutback, when the drive level reaches the amount needed to attain 110% output power; and overtemperature, VSWR, and overdrive faults. The board provides connections to the LCD Display for monitoring the % Reflected Power, % Output Power, and the power supply voltage.

If the Module OK LED, located on the front panel, is Red and blinking, a fault is present. The meaning of the blinking LED is as follows.

Table 4-2: Module OK LED Red and Blinking interpretation

Red LED Blinking	Meaning
1 Blink	Indicates Amplifier Current Fault
2 Blinks	Indicate Temperature Fault
3 Blinks	Indicate +32V Power Supply Over Voltage Fault
4 Blinks	Indicate +32V Power Supply Under Voltage Fault
5 Blinks	Indicate Reflected Power Fault
6 Blinks	Indicate +12V or -12V Power Supply Fault
7 Blinks	Indicate AGC Overdrive Fault

4.2.2.5.1 Schematic Page 1

U4, located upper center of page, is an in circuit microcontroller. The controller is operated at the frequency of 3.6864 MHz using crystal Y1. Programming of this device is performed through the serial programming port J2. U4 selects the desired analog channels of U3 through the settings of PA0-PA2. The outputs of Port A must be set and not changed during an analog input read of channels PA3-PA7. PA3 of U4 is a processor operating LED that monitors the +7 VDC. PA6 is the selected channel of analog switch U1.

U2 is a serial to RS-485 driver IC. U5 is a watchdog IC used to hold the microprocessor in reset, if the supply voltage is less than 4.21 VDC. U5 momentarily resets the microcontroller if Pin 6 (ST) is not clocked every second. A manual reset switch is provided but should not be needed.

In the Upper left corner, U1 is used to determine where the amplifier control board is located. The eight inputs come from the main amp connector and are used to set the SCADA address of the controller. Pull-up resistors set a default condition of logic high.

The IC above U8 controls the four board mounted status LEDs. A FET is turned On to shunt current away from the LED to turn it Off. U8 is not used in this configuration.

4.2.2.5.2 Schematic Page 2

In the lower right corner are voltage regulator circuits. U17 provides a regulated +7 VDC output using the +12 VDC input. U18 and U19 are low drop out +5 VDC, voltage regulators from +7 VDC inputs with a tolerance greater than or equal to 1%. 100mA of current is available from each device. U18 provides +5V_{analog} and U19 provides +5V_{digital} outputs.

In the center left section of the schematic are circuits using U12B and U13A that monitor the +32 VDC power supply voltage level. U12B pin 7 goes Low in the event of high power supply voltage, approximately +35.4 VDC or higher, producing a power supply High fault. U13A pin 1 goes Low if the power supply voltage drops lower than approximately +25.4 VDC, producing a power supply Low fault.

4.2.2.5.3 Current monitoring sections of the board.

The ICs U14 for Amp #1, U15 for Amp #2, and U16 for Amp #3, along with

associated components set up the current monitoring sections of the board.

The IC U10A is controlled by U14. A high at U10A pin 1 indicates normal, a Low indicates high current, above 5 Amps, and a fault alert is generated. The IC U10B is controlled by U15. A high at U10B pin 1 indicates normal, a Low indicates high current, above 15 Amps, and a fault alert is generated. The IC U12A is controlled by U16. A high at U12A pin 1 indicates normal, a Low indicates high current, above 15 Amps, and a fault alert is generated.

R67, R68 and R69, near U14, U15 and U16, are 0.010/5W 1% through hole resistors used for monitoring the current through several sections of the amplifier modules. The voltages developed across these resistors are amplified for current monitoring by U14, U15 or U16. The LT1787HVCS8 precision high side current sense IC amplifier accepts a maximum voltage of 60 VDC. The 43.2 kO resistor from pin 5 to ground sets the gain of the amplifier to about 17.28. This value is not set with much accuracy since the manufacturer internally matches the resistors of this part but their actual resistance value is not closely defined. A trimming resistor is suggested to give a temperature stability of -200 ppm/C, but instead the microcontroller will determine the exact gain of the circuit and use a correction factor for measurements. Circuit loading components are located in the lower portion of each current monitoring circuit. These components allow for short duration high current loading of the supply by measuring the current through the sense resistor with and without the additional four 30.1 O 1% resistors. For very short duration pulses, a 1206 resistor can handle up to 60 watts. The processor requires 226 uSec per conversion. A supply voltage of +32 VDC will pass 1.06 amps + 1% through the load resistors.

A6 is a temperature sensor thermistor, mounted on the heatsink of the amplifier module, which is used to monitor the

temperature of the heat sink. It connects to J6 pins 1 & 2 on the board and is wired to the comparator IC U13B. If the temperature increases above 75°C the output will go Low that is used as a temperature fault output, which generates a Fault alert and disables the Amplifier.

4.2.2.5.4 Schematic Page 3, Digital and Reflected power detector sections of the board.

A Digital Power Sample enters the board at the SMA Jack J3 and is split. One part connects to J4 on the board that is the SMA Digital Power Sample Jack, located on the front panel of the assembly.

NOTE: In this configuration, the Jumper W3 on J12 is connected between pins 1 & 2, which uses the digital average sample path. The other part of the split digital power sample is averaged by U26 and associated components and connected to R201, the Average Power Calibration Adjustment. R201 sets the level to the IC U22B, which amplifies the digital power sample before it is split. One digital power sample (Average Power) connects back to U4 on Page 1. Another average power sample connects through the jumper on J12 to a split point. A sample of the digital power (Selected Forward Power) connects back to U3 on Page 1. The digital power sample connects to amp U27B whose output is level detected by CR29, CR28 and CR30 and connected back to Page 1 (Average Power Remote) at J8-7 for remote use.

A Digital Reflected Power Sample enters the board at the SMA Jack J5 and is detected by CR31 and the DC level amplified by U21B. The output of U21B at pin 7 is connected through the digital/visual reflected calibration pot R203 to U25A. The output is split with one part connected to the (Reflected Pwr V) connection on Page 1 of the schematic that connects to U3. The other part of the split from U25A connects to the comparator IC U25B that has a reference level connected to Pin 5. If the reflected

level increases above the reference level a low Fault output is produced and connected to the Reflected Power Shutdown V circuit on Page 2 at CR14 & CR15, which produces a Reflected Power Fault V that is connected to an output of the board, the Fault Alert circuit and also shuts down the Amplifier.

NOTE: The Aural forward and reflected portions of this board, whose description follows, are not used in this digital transmitter.

An Aural Power Sample enters the board at the SMA Jack J13 and is split. One part connects to J14 on the board that is the Aural Power Sample Jack, located on the front panel of the assembly. The other part of the split aural power sample is detected by CR36 and the DC level amplified by U28A. The output of U28A at pin 1 is connected to R204, the Aural Power Calibration Adjustment. R204 sets the level to the IC U29A, which amplifies the aural power sample before it is split. One aural power sample, Aural Power connects back to U4 on Page 1. Another aural power sample connects to amp U29B whose output is level detected by CR39, CR37 and CR40 and back to Page 1, Aural Power Remote, at J8-9 for remote use. An Aural Reflected Power Sample enters the board at the SMA Jack J15 and is detected by CR41 and the DC level amplified by U28B. The output of U28B at pin 7 is connected through the aural reflected calibration pot R205 to U30A. The output is split with one part connected to the Reflected Pwr A connection on Page 1 of the schematic that connects to U3. The other part of the split from U30A connects to the comparator IC U30B that has a reference level connected to Pin 5. If the reflected level increases above the reference level a low Fault output is produced and connected to the Reflected Power Shutdown A circuit on Page 2 at CR43 & CR44, which produces a Reflected Power Fault A that is connected to an output of the board, the Fault Alert circuit and also shuts down the Amplifier.

The level of the output power measurements is completed through software. Only the Aural Null and Offset Null need to be adjusted through front panel pots.

This completes the circuit description of the Power Amplifier Module Assembly and the entire Driver/Amplifier Assembly.

Chapter 5 Detailed Alignment Procedures

5.1 System Preparation

This transmitter was aligned at the factory and should not require additional adjustments to achieve normal operation.

This transmitter takes the SMPTE 310 digital stream input and converts it to the desired UHF On Channel RF Output that is amplified to produce the systems output power level.

The Driver/Amplifier and the Power Amplifier Assemblies of the Innovator HX Series transmitter are of a Modular design and when a Module fails that module needs to be changed out with a replacement module. The failed module can then be sent back to Axcera for repair. Contact Axcera Customer Service Department at 724-873-8100 or fax to 724-873-8105, before sending in any module.

5.2 Module Replacement

Module replacement on the HX Series products is a relatively simple process. In the Exciter/Driver assembly, the individual modules plug into a blind mating connector located on the chassis. To replace a module, refer to the following procedure.

Loosen the two grip lock connectors, located on the front panel, at the top and bottom of the module, counterclockwise until the module releases. The Modulator, IF Processor, Upconverter and Controller/Power Supply can then be gently pulled from the unit. To remove the Driver/Power Amplifier Module in the exciter/amplifier chassis assembly, the two cables, Input and Output, connected to the rear of the chassis must be removed. These two cables and also a 6/32" x 1/2" shipping screw, located between the two connectors, must be removed before the

module will slide out. After removal of the failed module, slide the replacement module in place and make certain it connects to the backplane board. Tighten the two grip lock connectors.

NOTE: If the replacement module is a driver/PA Module also replace the two cables to the rear of the exciter/amplifier chassis assembly. The 6/32" x 1/2" shipping screw does not need to be replaced. It is only used during shipping. If the replacement module does not slide in easily, verify it is properly aligned in the nylon tracks, located on both the top and bottom of the module.

After removal of the failed module, slide the replacement module in place and make certain it connects to the blind mate connector. Replace the two cables on the rear of the IPA chassis assembly. If the replacement module does not slide in easily, verify it is properly aligned in the nylon tracks, located on both the top and bottom of the module.

Note: Each Module has an assigned slot and will not fit properly or operate in the incorrect slot. Do not try to place a Module in the wrong slot as this may damage the slot or the connectors on the backplane board. Each module has the name of the module on the front, bottom for identification and correct placement. The Modules are placed in the unit from left to right; (1) Axciter Downconverter, (2) Blank panel, (3) Blank Panel, (4) Axciter Upconverter, (5) Controller/Power Supply and (6) Driver Power Amplifier.

5.3 Initial Test Set Up

Check that the RF output at the DTV Mask Filter is terminated into a dummy load of at least the rated output of the system or connected to the antenna for

your system. While performing the alignment, refer to the Test Data Sheet for the transmitter and compare the final readings from the factory with the readings on each of the modules. The readings should be very similar. If a reading is way off, the problem is likely to be in that module.

Switch On the main AC for the system and the individual circuit breakers on each cabinet. Check that AC is present to all systems.

This transmitter operates using a SMPTE 310 input that connects to J27, the MPEG Input Jack, located on the rear of each Exciter Modulator Trays in the exciter control cabinet. Check that the MPEG input is present. If used, check that the 10 MHz input from the GPS is connected to J9 on the Exciter Modulator.

The GUI screen, located at the top front of the Control/Exciter Cabinet, controls the functional operation of the transmitter and in turn the exciter.

The check of and the setup of the drive levels are completed using the LCD Display and the front panel adjustments located on the Exciter Modulator Tray. The level of the RF output which includes adjustment of the drive level of the Intermediate Power Amplifier and the adjustment of the linearity and phase pre-distortion to compensate for any nonlinear response of the Power Amplifiers are controlled within the Exciter Modulator Tray.

NOTE: Refer to the separate Exciter Instruction Manual for detailed information.

5.4 Setting Up the Output Power of the Transmitter

NOTE: In dual exciter systems perform the following procedures with Exciter A as the ON Air Exciter then repeat with Exciter B as the On Air Exciter. The following adjustments are completed using the LCD screen located on the front panel of the Exciter Modulator Tray. On the Exciter Main Screen, push the button next to the Upconverter tab on the right side of the screen. This will open the Upconverter Main Screen. Set the AGC to Manual by selecting 3 on the key board entry. The screen will now indicate AGC Manual. Set the transmitter to full power using the Driver/Amplifier LCD display while viewing the Power Control Screen in the Set Up Menu.

5.4.1 Setting up of AGC 1

To set up the AGC, first the AGC must be activated. Locate the 8 position DIP switch SW1 mounted on the Control Board in the Exciter Upconverter Sled, mounted in the HX Driver/Amplifier Assembly. The Upconverter DIP Switch Position 6 must be switched ON which allows the user to modify the AGC 1 and AGC 2 gain through the Exciter Modulator.

See Figure 5-1 for an example of the Exciter Upconverter Main Screen. On the Exciter Upconverter Screen set AGC 1 to 1.5 Volts, by selecting 4 on the key board entry. This will cause a detail screen to appear prompting you to enter a number value. Monitor the AGC 1 Gain Value on the screen and increase or decrease the value of the number entered until the monitored reading is 1.5 Volts.

Figure 5-1: Axciter Upconverter Main Screen



5.4.2 Setting up of AGC 2

On the Axciter Upconverter Screen set AGC 2 to 1.7 Volts, by selecting 5 on the key board entry. This will cause a detail screen to appear prompting you to enter a number value. Monitor the AGC 2 Gain Value on the screen and increase or decrease the value of the number entered until the monitored reading is 1.7 Volts.

After the setting up of the AGC, the AGC must be de-activated to prevent accidental changes. The Upconverter DIP Switch SW1 Position 6 must be switched OFF which locks the AGC 1 and AGC 2 gain.

5.4.3 Setting up of Overdrive Threshold

On the Axciter Upconverter Screen set the Overdrive Threshold to 1.6 Volts, by selecting 7 on the key board entry. This will cause a detail screen to appear. Increase or decrease the voltage as needed until the monitored reading is 1.6 Volts.

Place the Transmitter into AGC by pushing the 3 of the key board entry on the Axciter Upconverter Screen. This will place the Transmitter AGC into Auto.

5.4.4 Axciter Relay Sample Values

RF samples to the Axciter Relay:
These levels are to be measured with a power meter before connecting them. Your installation may require RF attenuators to be placed in line with the

samples to get them within the desired range.

J1 connection to the FWD power sample of the coupler before the mask filter (Non-Linear Distortion).

Level into Relay at J1 should be 0 dBm to -10 dBm. -5 dBm typical

J2 connection to the forward power sample after the mask filter (Linear Distortion).

Level into Relay at J2 should be 0 dBm to -10 dBm. -5 dBm typical, but within .5 dB of the J1 sample.

5.4.5 Upconverter Down Converter Adjustment

On the Axciter Modulator, activate the Upconverter Main screen by selecting Upconverter using the button next to it on the right side of the Axciter Main Screen. Activate the Downconverter Output Gain by pushing 2 on the key board entry. Monitor the DTVision Linear Display by pushing the button next to the DTVision Linear display on the right side of the Axciter Main Screen. At the bottom of the DTVision linear screen, locate the reading next to RMS. If this reading is between -10 dBm & 0 dBm no adjustment is needed. If it is not, adjust the "Downconverter Gain", then view the RMS value until it is within the -10 dBm to 0 dBm range.

5.5 System Calibration of Forward and Reflected Powers Using the HX Driver/Amplifier

5.5.1 Forward Power Calibration

Check that transmitter is at 100% output power, as shown on the LCD display on the (A3) HX Driver/Amplifier in the Set Up menus.

Measure with a VOM, TP31-14, Red, and TP31-12, Black, at the terminal block TP31 located on the rear chassis of the (A3) HX Series Driver/Amplifier Chassis Assembly. Adjust R9, Forward Calibration Adjustment, on the (A4) Dual Peak Detector Board (1159965) for a reading of .8VDC on the VOM. Locate the Forward Power Adjust screen on the HX Driver/Amplifier LCD display in the Set Up menus and adjust the up or down arrow as needed to achieve 100 % output power.

This completes the forward power set up.

5.5.2 Reflected Power Calibration

Switch the transmitter to Standby. Remove the connector that is on Jack J2, on the (A4) Dual Peak Detector Board (1159965), and replace with the connector now on J1, also inserting a 10 dB pad in series. Switch the transmitter to operate. Monitor the LCD display on the (A3) HX Driver/Amplifier in the Set Up menus, reflected power screen. Adjust R10, Reflected Calibration Adjustment, on the (A4) Dual Peak Detector Board (1159965) for a reading of 10% on the display. Switch the transmitter to Standby. Move the connector back to J1 while removing the 10 dB pad. Replace the original connector onto J2.

NOTE: In a dual exciter system, repeat the above procedure with Exciter B selected as the On Air Exciter.

This completes the set up and adjustment of the transmitter.

If a problem occurred during alignment, contact Axcera field service at 1-(724) 873-8100.

Appendix A

System Specifications

High Power Solid State UHF & VHF Transmitters



With over twenty years of experience in the design and manufacture of solid state transmitters, Axcera continues to provide the latest technology, enabling our customers to focus on the future. The Innovator HX high power solid state transmitter is available in power levels up to 100kW analog and 60 kW DTV using the latest control, signal generation and RF amplifier technology, ensuring long-term support.

These advanced solid state transmitters were designed specifically to meet the needs of today's broadcaster, offering high levels of reliability, efficiency and performance. The modular construction provides a clear upgrade path, allowing broadcasters to begin with a low power transmitter and easily add modules to achieve any power level desired. With parallel amplifiers, in-circuit programmable control system and a choice of parallel linear or switching power supplies, the Innovator HX is perfect for long-term, unattended operation.

High Power Solid State UHF & VHF Transmitters



Digital Exciter-Modulator

100% DSP BASED

The DT2B digital television modulator represents the industry's most advanced ATSC exciter technology. Building on the field proven hardware platform of Axcera's digital exciter family, the DT2B offers terrestrial broadcasters the most flexible solution available. Because it operates using 100% digital signal processing, the DT2B can evolve as broadcast requirements change, helping to protect your investment for many years to come. For COFDM operation, the Innovator™ DT is compatible with modulators from most COFDM modulator manufacturers.

Parallel Broadband Amplifier Modules

NO TUNING REQUIRED

Every Innovator HX transmitter is comprised of highly reliable broadband amplifier modules operating in a parallel configuration. Each module covers the entire operating band with no tuning required and is designed to accept high power transistors from multiple manufacturers, providing very efficient and linear operation and ensuring future support. For convenience, each amplifier module operates independently, allowing easy removal and replacement while the transmitter is on the air, and all digital and analog power amplifier modules are interchangeable.

Linear or Switching Power Supplies

THE CHOICE IS YOURS

The Innovator HX is available with either traditional linear power supplies or modern switching supplies, each offering specific benefits to the user.

High Efficiency Air-Cooling

QUIET, EFFICIENT & STRAIGHTFORWARD COOLING SYSTEM DESIGN

The Innovator HX uses a hollow-fin heat-sink design that minimizes the power amplifier module size without com-

promising cooling efficiency, resulting in a very small overall transmitter footprint. This unique low-pressure system provides higher efficiency and less blower noise than other designs. By providing low junction temperatures for the transistor devices, this cooling system ensures that high reliability and optimum device life are easily achieved.

Adaptive Digital Equalization (ADE™)

AN INDUSTRY FIRST

Standard on all digital Innovator™ HX transmitters, Axcera's exclusive Adaptive Digital Equalization (ADE™) provides dynamic digital pre-correction, automatically tracking and correcting for distortions, both linear and non-linear, in the complete transmitter system.

The continuous, real-time, non-linear component of ADE™ is by far the most critical element of the correction system. Since the majority of linear distortions are caused by factors external to the transmission system, ATSC set-top boxes are designed to correct for large amounts of linear distortions. However, since DTV receivers cannot correct for non-linear distortions, this must be handled in the transmitter system or coverage will be affected in the fringe areas.

Control & Monitoring

IN-CIRCUIT PROGRAMMABLE CONTROLLER ENSURES FUTURE SUPPORT

All control and monitoring functions of the transmitter are brought together in the in-circuit programmable control unit and can be accessed both through the full-color touchscreen graphical user interface (GUI) and the LCD menu located on the front panel of the controller.

Test values, status information, pre-sets and fault indications, as well as diagnostics to the component level are provided through the LCD display and the GUI, and can be accessed remotely through a serial interface.

DTVision Signal Analysis

UNIQUE SYSTEM CONTROL & ANALYSIS

Available on digital Innovator™ HX transmitters is Axcera's exclusive DTVision™ digital signal analysis and test system. Designed to replace expensive DTV test equipment at a fraction of the price, this system samples the transmitter output, measures critical transmitter performance parameters, and displays the sampled information on the modulator's front panel display – no external PC is required.

High Power Solid State UHF & VHF Transmitters

Typical Single PA Cabinet Architecture

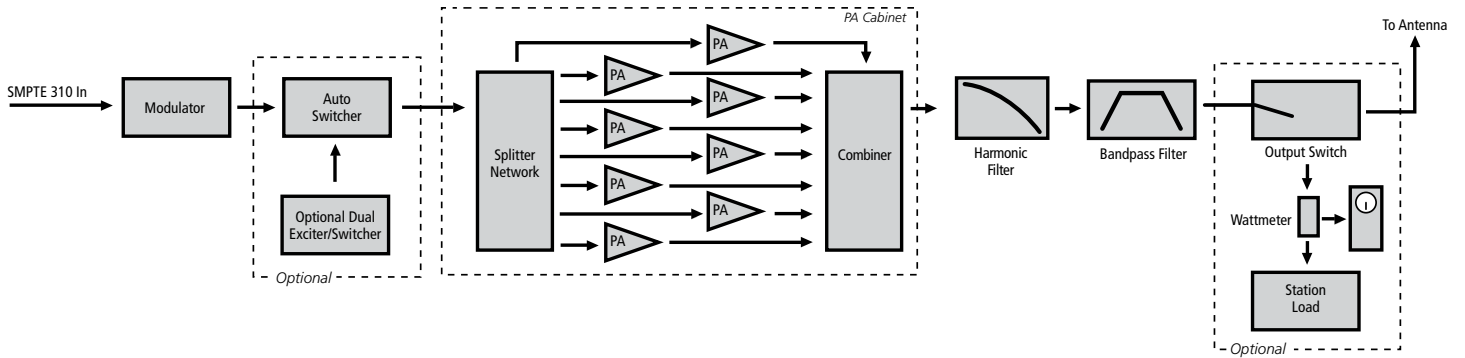

Typical Multiple PA Cabinet Architecture

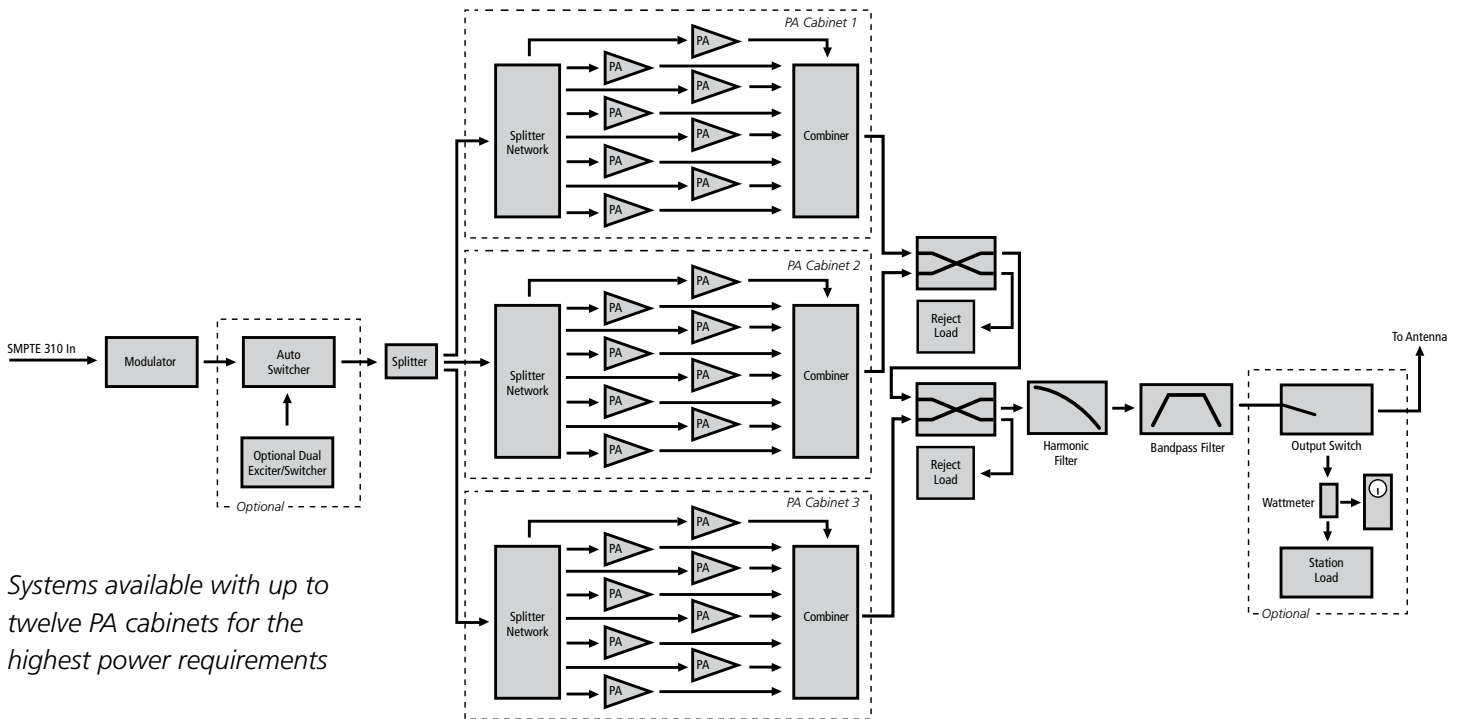

Systems available with up to twelve PA cabinets for the highest power requirements

High Power Solid State UHF & VHF Transmitters

Performance

Frequency Range ¹	
HLV	54 to 88 MHz
HHV	174 to 216 MHz
HU	470 to 806 MHz
Output Impedance	50 Ω - coaxial/waveguide
Frequency Stability	±1 kHz (max 30 day variation)
w/Precise Frequency Option	±2 Hz
Regulation of RF Output Power	3%
Out of Band -Compliant with FCC Mask	
Channel Edge ±500kHz	-47 dB or better
6MHz from Channel Edge	-110 dB or better
Signal to Noise (SNR)	27 dB or better
Data Interface	
Input Rate	19.39 Mbps, 6 MHz Channel
Input Interface	SMPT E 310M

General

Operational Temperature Range	0 to +45° C, derate 2° C/1000 ft.
Maximum Altitude ¹	8500 ft. (2600 m) AMSL
Operational Humidity Range	0% to 95% non-condensing
RF Load Impedance	50 Ω
Line Voltage ¹ (User Specified)	208 or 240 VAC, 3 Phase
Power Factor (With Switching Supplies Option) ²	0.95

Options

Switching Power Supplies²
 DTVision Signal Analysis System
 Bandwidth Enhancement Technology
 Dual Exciter with Automatic Switcher
 AC Surge Protector
 Precise Frequency Kit
 Spare Parts Kit

¹ For other frequencies, altitudes and voltages - Consult Factory

² Switching supplies available for VHF models only

³ "x" denotes operating band

⁴ Measured after Typical RF System. For custom configurations please contact the factory.

Model Specific Specifications

Model Number ³	Hx2500AD	Hx5000AD	Hx7500AD	Hx10KAD	Hx15KAD	Hx20KAD	Hx25KAD
Power Output ⁴	2.5 kW	5 kW	7.5 kW	10 kW	15 kW	20 kW	25 kW
Power Consumption	14 kW	28 kW	41 kW	55 kW	83 kW	110 kW	138 kW
Dimensions (H x W x D)							
Inches	79" x 47" x 50"	79" x 47" x 50"	79" x 71" x 50"	79" x 71" x 50"	79" x 95" x 50"	79" x 118" x 50"	79" x 142" x 50"
Centimeters	200 x 120 x 127	200 x 120 x 127	200 x 180 x 127	200 x 180 x 127	200 x 240 x 127	200 x 300 x 127	200 x 360 x 127

Model Specific Specifications

Model Number ³	Hx30KAD	Hx35KAD	Hx40KAD	Hx45KAD	Hx50KAD	Hx55KAD	Hx60KAD
Power Output ⁴	30 kW	35 kW	40 kW	45 kW	50 kW	55 kW	60 kW
Power Consumption	166 kW	194 kW	220 kW	245 kW	275 kW	300 kW	330 kW
Dimensions (H x W x D)							
Inches	79" x 165" x 50"	79" x 189" x 50"	79" x 212" x 50"	79" x 236" x 50"	79" x 260" x 50"	79" x 284" x 50"	79" x 307" x 50"
Centimeters	200 x 420 x 127	200 x 480 x 127	200 x 540 x 127	200 x 600 x 127	200 x 660 x 127	200 x 720 x 127	200 x 780 x 127

Specifications published here are current as of the date of publication of this document. Because we are continuously improving our products, Axcera reserves the right to change specifications without prior notice. At any time, you may verify product specifications by contacting our office. Axcera views its patent portfolio as an important corporate asset and vigorously enforces its patents. Products or features contained herein may be covered by one or more U.S. or foreign patents.

Appendix B
System Drawings

Appendix B Drawing List

HU5000AD Transmitter System Block Diagram	1310994
HU5000AD Transmitter System Interconnect.....	1310995

Appendix C
Control Cabinet
Drawings

Appendix C Drawing List

Digital UHF Control Cabinet, HX Series	
Control Cabinet Single Exciter Block Diagram.....	1308241
Control Cabinet Single Exciter Interconnect	1307571
Control Cabinet AC Interconnect.....	1307037
Dual Peak Detector Board	
Schematic.....	1159976
Serial Loop-Thru Board	
Schematic.....	1307812

Appendix D

UHF Exciter/Driver Assembly Drawings

Appendix D Drawing List

Exciter/Driver Chassis Assembly, 110 VAC, HX Series

Interconnect..... 1305554

Backplane Board, HX Series, Axciter

Schematic..... 1307308

NOTE: The Upconverter Module and Downconverter Module drawings are located in the separate Axciter Manual.

Control/Power Supply Assembly, 110 VAC

Block Diagram..... 1303889

Interconnect..... 1302062

Control Board

Schematic..... 1302023

Power Protection Board

Schematic..... 1302839

Switch Board

Schematic..... 1527-3406

Power Amplifier Assembly, UHF Driver

Block Diagram..... 1306026

Interconnect..... 1306025

Coupler Board Assembly

Block Diagram..... 1227-3316

RF Module Pallet w/o Transistors (Made into a RF Module Pallet, Phillips 1300116)

Schematic..... 51-5379-309-00WSP

1-Watt UHF Amplifier Board (Mounted in a 1 Watt UHF Module Assembly 1302891)

Schematic..... 1302762

Amplifier Control Board

Schematic..... 1304776