INSTRUCTION MANUAL

INNOVATOR LX SERIES

UHF ANALOG DRIVER/UHF TRANSLATOR

AXCERA, LLC

103 FREEDOM DRIVE P.O. BOX 525 LAWRENCE, PA 15055-0525 USA
(724) 873-8100 • FAX (724) 873-8105
www.axcera.com • info@axcera.com



SECTION	TABLE OF CONTENTS	PAGE
CHAPTER 1 INTRODUCTION		
1.1 Manual Overview		1-1
1.2 Assembly Designation Numbers		1-1
1.3 Safety.....		1-1
1.4 Maintenance		1-2
1.5 Material Return Procedure.....		1-2
1.6 Limited One-Year Warranty for Axcera Products		1-3
CHAPTER 2 SYSTEM DESCRIPTION & REMOTE CONTROL CONNECTIONS		
2.1 System Overview		2-1
2.1.1 Receiver Tray		2-2
2.1.2 IF Processor Module		2-3
2.1.3 LO/Upconverter Module		2-5
2.1.4 Control & Monitoring/Power Supply Module		2-7
2.1.5 Power Amplifier Module		2-8
2.1.6 RF Output Assemblies.....		2-9
2.2 Control and Status		2-9
2.2.1 Front Panel LCD Display Screen.....		2-10
2.3 System Operation		2-10
2.3.1 Principles of Operation.....		2-11
2.4 Customer Remote Connections		2-12
CHAPTER 3 SITE CONSIDERATIONS, INSTALLATION AND SETUP PROCEDURES		
3.1 Site Considerations.....		3-1
3.2 Unpacking the Chassis w/Modules and Receiver Tray.....		3-4
3.3 Installing the Chassis w/Modules and Receiver Tray		3-4
3.4 AC Input		3-6
3.5 Setup and Operation.....		3-6
3.5.1 Input Connections		3-7
3.5.2 Front Panel Screens for the Exciter/Amplifier Chassis Assembly		3-9
CHAPTER 4 CIRCUIT DESCRIPTIONS		
4.1 Receiver Tray.....		4-1
4.1.1 50-Ohm Filter		4-1
4.1.2 Dual Stage Amplifier Assembly		4-1
4.1.3 Channel Filter		4-1
4.1.4 Downconverter Amplifier Assembly		4-2
4.1.5 Channel Oscillator Assembly		4-2
4.1.6 x8, x2, x4 Multiplier Board		4-2
4.1.7 L.O. Filter		4-2
4.1.8 IF Filter/ALC Board		4-2
4.1.9 SAW Board (Optional)		4-2
4.1.10 IF Amplifier Board (Optional)		4-3
4.1.11 IF Filter/Limiter Board (Optional)		4-3
4.1.12 IF PLL Board (Optional)		4-3
4.1.13 IF Carrier Oven Oscillator (Optional)		4-3

TABLE OF CONTENTS - (Continued)

SECTION	PAGE
4.1.14 +/- 12V Power Supply Board	4-4
4.2 IF Processor Module	4-4
4.2.1 IF Processor Board	4-4
4.3 LO/Upconverter Module	4-10
4.3.1 UHF Generator Board	4-10
4.3.2 UHF Filters	4-11
4.3.3 LO/Upconverter Board	4-11
4.4 Control Monitoring/Power Supply Module	4-15
4.4.1 Power Protection Board	4-16
4.4.2 Control Board	4-16
4.4.3 Switch Board	4-19
4.4.4 Switching Power Supply Assembly	4-19
4.5 Power Amplifier Module Assembly	4-19
4.5.1 1-Watt Amplifier Module Assembly	4-19
4.5.2 1-Watt UHF Amplifier Board	4-19
4.5.3 40 Watt UHF Amplifier Assembly	4-20
4.5.4 UHF Module Assembly, RF Module Pallet	4-20
4.5.5 Coupler Board Assembly	4-21
4.5.6 Amplifier Control Board	4-21
CHAPTER 5 DETAILED ALIGNMENT PROCEDURES	
Module Replacement	5-1
Initial Test Setup	5-1
5.1 UHF/VHF Receiver Tray	5-2
5.1.1 UHF Filter	5-2
5.1.2 Dual Stage Amplifier Board	5-2
5.1.3 UHF Filter	5-2
5.1.4 Channel Oscillator Assembly	5-2
5.1.5 x8, x4, x2 Multiplier Board	5-3
5.1.6 UHF Filter	5-4
5.1.7 Downconverter Amplifier Board	5-4
5.1.8 IF Filter/ALC Board	5-4
5.1.9 SAW Filter Board (Optional)	5-4
5.1.10 +/- 12V Power Supply	5-4
5.1.11 IF Carrier Oscillator Board (Optional)	5-4
5.1.12 IF Filter/Limiter Board	5-4
5.1.13 IF PLL Board (Optional)	5-4
5.1.14 IF Amplifier Board, High Gain (Optional)	5-5
5.2 Innovator LX Series Exciter/Amplifier Chassis Assembly	5-6
5.2.1 Linearity Correction Adjustment	5-6
5.2.2 Frequency Response Delay Equalization Adjustment	5-7
5.2.3 Calibration of Output Power and Reflected Power	5-7
5.3 Alignment Procedure for the Band-pass Filter Assembly	5-8
APPENDICES	
APPENDIX A SYSTEM SPECIFICATIONS	
APPENDIX B DRAWINGS AND PARTS LISTS	

LIST OF FIGURES		
FIGURE		PAGE
3-1	1 kW Minimum Ventilation Configuration	3-4
3-2	Tray Slide Cabinet Mounting Diagram.....	3-5
3-3	Front and Rear View Reconnection Drawing	3-6
3-4	Rear View of Innovator LX Series UHF Translator	3-7
5-1	Typical Red Field Spectrum.....	5-7

LIST OF TABLES

TABLE		PAGE
2-1	10-100W Innovator LX Series Translator Assemblies and Tray	2-1
2-5	Receiver Samples	2-2
2-6	IF Processor Front Panel Switch.....	2-4
2-7	IF Processor Front Panel Status Indicators	2-4
2-8	IF Processor Front Panel Control Adjustments.....	2-4
2-9	IF Processor Front Panel Sample	2-4
2-10	LO/Upconverter Front Panel Switch.....	2-6
2-11	LO/Upconverter Front Panel Status Indicators	2-6
2-12	LO/Upconverter Front Panel Control Adjustments.....	2-6
2-13	LO/Upconverter Front Panel Samples.....	2-6
2-14	Controller/Power Supply Front Panel Display	2-7
2-15	Controller/Power Supply Front Panel Status Indicators	2-7
2-16	Controller/Power Supply Front Panel Control Adjustments.....	2-7
2-17	Power Amplifier Front Panel Status Indicators.....	2-9
2-18	Power Amplifier Front Panel Control Adjustments.....	2-9
2-19	Power Amplifier Front Panel Sample	2-9
2-22	VHF Television Frequencies.....	2-11
2-23	UHF Television Frequencies	2-11
2-25	Innovator LX Series Chassis Customer Remote Connections.....	2-13
3-1	Rear Chassis Connections for Receiver Tray	3-7
3-2	Rear Chassis Connections for LX Series Translators (driver)	3-7
3-3	Menu 01 Splash Screen #1.....	3-9
3-4	Menu 02 Splash Screen #2.....	3-9
3-5	Menu 10 Main Screen	3-9
3-6	Menu 11 Error List Screen.....	3-10
3-7	Menu 12 Translator Device Data Access Screen	3-10
3-8	Menu 13 Translator Configuration Access Screen.....	3-10
3-9	Menu 20 Error List Display Screen.....	3-10
3-10	Menu 30 Translator Device Details Screen	3-10
3-11	Translator Device Parameters	3-12
3-12	Menu 40 Translator Set Up: Power Raise/Lower Screen.....	3-13
3-13	Menu 40-1 Translator Set Up: Xltr. Model Select Screen.....	3-13
3-14	Menu 40-2 Translator Set Up: Frequency Select Screen.....	3-13
3-15	Menu 40-3 Translator Set Up: Frequency Table Select Screen.....	3-13
3-16	Menu 40-4 Translator Set Up: IF Frequency Screen.....	3-14
3-17	Menu 40-5 Translator Set Up: Custom Frequency Select Screen.....	3-14
3-18	Menu 40-6 Translator Set Up: Serial Address Screen	3-14
3-19	Menu 40-7 Translator Set Up: Xltr. Visual Power Cal. Screen.....	3-14
3-20	Menu 40-8 Translator Set Up: Xltr. Aural Power Cal. Screen.....	3-15
3-21	Menu 40-9 Translator Set Up: Xltr. Rfltd. Power Cal. Screen.....	3-15
3-22	Menu 40-10 Translator Set Up: Fwd. Power Fault Thresh. Screen.....	3-15
3-23	Menu 40-11 Translator Set Up: Rfltd. Power Fault Thresh. Screen.....	3-15
3-23	Menu 40-12 Translator Set Up: Remote Commands Control	3-16

Chapter 1 Introduction

This manual explains the installation, setup, alignment, and maintenance procedures for the Innovator LX Series modular UHF translator. It is important that you read all of the instructions, especially the safety information in this chapter, before you begin to install or operate the unit.

1.1 Manual Overview

This instruction manual is divided into five chapters and supporting appendices. Chapter 1, Introduction, contains information on the assembly numbering system used in the manual, safety, maintenance, return procedures, and warranties. The second chapter describes the translator and includes discussions on system control and status indicators and remote control connections. Chapter 3 explains how to unpack, install, setup, and operate the translator. Chapter 4 contains circuit-level descriptions for boards and board-level components in the translator. Chapter 5, Detailed Alignment Procedures, provides information on adjusting the system assemblies for optimal operation. The appendices contain a sample log sheet, test data sheet, assembly and subassembly drawings and parts lists, and system specifications.

1.2 Assembly Designators

Axcera has assigned assembly numbers, such as Ax (x=1,2,3...), to all assemblies, trays, and boards that are referenced in the text of this manual and shown on the block diagrams and interconnect drawings provided in the appendices. These supporting documents are arranged in increasing numerical order in the appendices. Section titles in the text for assembly or tray descriptions or alignment procedures contain the associated part number(s) and the

relevant appendix that contains the drawings for that item.

1.3 Safety

The UHF translators manufactured by Axcera are designed to be easy to use and repair while providing protection from electrical and mechanical hazards. Listed throughout the manual are notes, cautions, and warnings concerning possible safety hazards that may be encountered while operating or servicing the translator. Please review these warnings and familiarize yourself with the operation and servicing procedures before working on the translator.

Read All Instructions – All of the operating and safety instructions should be read and understood before operating this equipment.

Retain Manuals – The manuals for the translator should be retained at the translator site for future reference. We provide two sets of manuals for this purpose; one set can be left at the office while one set can be kept at the site.

Heed all Notes, Warnings, and Cautions – All of the notes, warnings, and cautions listed in this safety section and throughout the manual must be followed.

Follow Instructions – All of the operating and use instructions for the translator should be followed.

Cleaning – Unplug or otherwise disconnect all power from the equipment before cleaning. Do not use liquid or aerosol cleaners. Use a damp cloth for cleaning.

Ventilation – Openings in the cabinets and tray front panels are provided for ventilation. To ensure the reliable

operation of the translator, and to protect the unit from overheating, these openings must not be blocked.

Servicing – Do not attempt to service this product yourself until becoming familiar with the equipment. If in doubt, refer all servicing questions to qualified Axcera service personnel.

Replacement Parts – When replacement parts are used, be sure that the parts have the same functional and performance characteristics as the original part. Unauthorized substitutions may result in fire, electric shock, or other hazards. Please contact the Axcera Technical Service Department if you have any questions regarding service or replacement parts.

1.4 Maintenance

The Innovator LX Series Translator is designed with components that require little or no periodic maintenance except for the routine cleaning of the fans and the front panels of the trays.

The amount of time between cleanings depends on the conditions within the transmitter room. While the electronics have been designed to function even if covered with dust, a heavy buildup of dust, dirt, or insects will affect the cooling of the components. This could lead to a thermal shutdown or the premature failure of the affected trays.

When the front panels of the trays become dust covered, the top covers should be taken off and any accumulated foreign material should be removed. A vacuum cleaner, utilizing a small, wand-type attachment, is an excellent way to suction out the dirt. Alcohol and other cleaning agents should not be used unless you are certain that the solvents will not damage components or the silk-screened markings on the trays and boards. Water-based cleaners can be used, but do not saturate the components. The fans and heatsinks

should be cleaned of all dust or dirt to permit the free flow of air for cooling purposes.

It is recommended that the operating parameters of the translator be recorded from the meters on the trays and the system metering control panel at least once a month. It is suggested that this data be retained in a rugged folder or envelope. A sample format for a log sheet is provided in Appendix A. Photocopies of the log sheet should be made to allow for continued data entries.

1.5 Material Return Procedure

To insure the efficient handling of equipment or components that have been returned for repair, Axcera requests that each returned item be accompanied by a Material Return Authorization Number (MRA#).

An MRA# can be obtained from any Axcera Field Service Engineer by contacting the Axcera Field Service Department at (724) 873-8100 or by fax at (724) 873-8105. This procedure applies to all items sent to the Field Service Department regardless of whether the item was originally manufactured by Axcera.

When equipment is sent to the field on loan, an MRA# is included with the unit. The MRA# is intended to be used when the unit is returned to Axcera. In addition, all shipping material should be retained for the return of the unit to Axcera.

Replacement assemblies are also sent with an MRA# to allow for the proper routing of the exchanged hardware. Failure to close out this type of MRA# will normally result in the customer being invoiced for the value of the loaner item or the exchange assembly.

When shipping an item to Axcera, please include the MRA# on the packing list and on the shipping container.

The packing slip should also include contact information and a brief description of why the unit is being returned.

Please forward all MRA items to:

AXCERA, LLC
103 Freedom Drive
P.O. Box 525
Lawrence, PA 15055-0525 USA

For more information concerning this procedure, call the Axcera Field Service Department.

Axcera can also be contacted through e-mail at **info@axcera.com** and on the Web at **www.axcera.com**.

1.6 Limited One-Year Warranty for Axcera Products

Axcera warrants each new product that it has manufactured and sold against defects in material and workmanship under normal use and service for a period of one (1) year from the date of shipment from Axcera's plant, when operated in accordance with Axcera's operating instructions. This warranty shall not apply to tubes, fuses, batteries, or bulbs.

Warranties are valid only when and if (a) Axcera receives prompt written notice of breach within the period of warranty, (b) the defective product is

properly packed and returned by the buyer (transportation and insurance prepaid), and (c) Axcera determines, in its sole judgment, that the product is defective and not subject to any misuse, neglect, improper installation, negligence, accident, or (unless authorized in writing by Axcera) repair or alteration. Axcera's exclusive liability for any personal and/or property damage (including direct, consequential, or incidental) caused by the breach of any or all warranties, shall be limited to the following: (a) repairing or replacing (in Axcera's sole discretion) any defective parts free of charge (F.O.B. Axcera's plant) and/or (b) crediting (in Axcera's sole discretion) all or a portion of the purchase price to the buyer.

Equipment furnished by Axcera, but not bearing its trade name, shall bear no warranties other than the special hours-of-use or other warranties extended by or enforceable against the manufacturer at the time of delivery to the buyer. **NO WARRANTIES, WHETHER STATUTORY, EXPRESSED, OR IMPLIED, AND NO WARRANTIES OF MERCHANTABILITY, FITNESS FOR ANY PARTICULAR PURPOSE, OR FREEDOM FROM INFRINGEMENT, OR THE LIKE, OTHER THAN AS SPECIFIED IN PATENT LIABILITY ARTICLES, AND IN THIS ARTICLE, SHALL APPLY TO THE EQUIPMENT FURNISHED HEREUNDER.**

 **WARNING!!!****◀ HIGH VOLTAGE ▶**

DO NOT ATTEMPT TO REPAIR OR TROUBLESHOOT THIS EQUIPMENT UNLESS YOU ARE FAMILIAR WITH ITS OPERATION AND EXPERIENCED IN SERVICING HIGH VOLTAGE EQUIPMENT. LETHAL VOLTAGES ARE PRESENT WHEN POWER IS APPLIED TO THIS SYSTEM. IF POSSIBLE, TURN OFF POWER BEFORE MAKING ADJUSTMENTS TO THE SYSTEM.

★ RADIO FREQUENCY RADIATION HAZARD ★

MICROWAVE, RF AMPLIFIERS AND TUBES GENERATE HAZARDOUS RF RADIATION THAT CAN CAUSE SEVERE INJURY INCLUDING CATARACTS, WHICH CAN RESULT IN BLINDNESS. SOME CARDIAC PACEMAKERS MAY BE AFFECTED BY THE RF ENERGY EMITTED BY RF AND MICROWAVE AMPLIFIERS. NEVER OPERATE THE TRANSLATOR SYSTEM WITHOUT A PROPERLY MATCHED RF ENERGY ABSORBING LOAD ATTACHED. KEEP PERSONNEL AWAY FROM OPEN WAVEGUIDES AND ANTENNAS. NEVER LOOK INTO AN OPEN WAVEGUIDE OR ANTENNA. MONITOR ALL PARTS OF THE RF SYSTEM FOR RADIATION LEAKAGE AT REGULAR INTERVALS.

EMERGENCY FIRST AID INSTRUCTIONS

Personnel engaged in the installation, operation, or maintenance of this equipment are urged to become familiar with the following rules both in theory and practice. It is the duty of all operating personnel to be prepared to give adequate Emergency First Aid and thereby prevent avoidable loss of life.



RESCUE BREATHING

1. Find out if the person is breathing.

You must find out if the person has stopped breathing. If you think he is not breathing, place him flat on his back. Put your ear close to his mouth and look at his chest. If he is breathing you can feel the air on your cheek. You can see his chest move up and down. If you do not feel the air or see the chest move, he is not breathing.

2. If he is not breathing, open the airway by tilting his head backwards.

Lift up his neck with one hand and push down on his forehead with the other. This opens the airway. Sometimes doing this will let the person breathe again by himself.

3. If he is still not breathing, begin rescue breathing.

-Keep his head tilted backward.
-Pinch nose shut.
-Put your mouth tightly over his mouth.
-Blow into his mouth once every five seconds
-DO NOT STOP rescue breathing until help arrives.

LOOSEN CLOTHING - KEEP WARM

Do this when the victim is breathing by himself or help is available. Keep him as quiet as possible and from becoming chilled. Otherwise treat him for shock.

BURNS

SKIN REDDENED: Apply ice cold water to burned area to prevent burn from going deeper into skin tissue. Cover area with clean sheet or cloth to keep away air. Consult a physician.

SKIN BLISTERED OR FLESH CHARRED: Apply ice cold water to burned area to prevent burn from going deeper into skin tissue.

Cover area with clean sheet or cloth to keep away air. Treat victim for shock and take to hospital.

EXTENSIVE BURN - SKIN BROKEN: Cover area with clean sheet or cloth to keep away air. Treat victim for shock and take to hospital.

Note: Because of possible FCC assigned offset, check for the assigned Carrier Frequency as written on License.

UHF Channels NTSC Standard IF, 45.75 MHz							
Visual Carrier Frequency (MHz)				L.O. (MHz)	Crystal Frequency (MHz)		
Channel	Nominal	Minus	Plus	Nominal	Nominal	Minus	Plus
14	471.25	471.24	471.26	517.00	64.625	64.62375	64.62625
15	477.25	477.24	477.26	523.00	65.375	65.37375	65.37625
16	483.25	483.24	483.26	529.00	66.125	66.12375	66.12625
17	489.25	489.24	489.26	535.00	66.875	66.87375	66.87625
18	495.25	495.24	495.26	541.00	67.625	67.62375	67.62625
19	501.25	501.24	501.26	547.00	68.375	68.37375	68.37625
20	507.25	507.24	507.26	553.00	69.125	69.12375	69.12625
21	513.25	513.24	513.26	559.00	69.875	69.87375	69.87625
22	519.25	519.24	519.26	565.00	70.625	70.62375	70.62625
23	525.25	525.24	525.26	571.00	71.375	71.37375	71.37625
24	531.25	531.24	531.26	577.00	72.125	72.12375	72.12625
25	537.25	537.24	537.26	583.00	72.875	72.87375	72.87625
26	543.25	543.24	543.26	589.00	73.625	73.62375	73.62625
27	549.25	549.24	549.26	595.00	74.375	74.37375	74.37625
28	555.25	555.24	555.26	601.00	75.125	75.12375	75.12625
29	561.25	561.24	561.26	607.00	75.875	75.87375	75.87625
30	567.25	567.24	567.26	613.00	76.625	76.62375	76.62625
31	573.25	573.24	573.26	619.00	77.375	77.37375	77.37625
32	579.25	579.24	579.26	625.00	78.125	78.12375	78.12625
33	585.25	585.24	585.26	631.00	78.875	78.87375	78.87625
34	591.25	591.24	591.26	637.00	79.625	79.62375	79.62625
35	597.25	597.24	597.26	643.00	80.375	80.37375	80.37625
36	603.25	603.24	603.26	649.00	81.125	81.12375	81.12625
37	609.25	609.24	609.26	655.00	81.875	81.87375	81.87625
38	615.25	615.24	615.26	661.00	82.625	82.62375	82.62625
39	621.25	621.24	621.26	667.00	83.375	83.37375	83.37625
40	627.25	627.24	627.26	673.00	84.125	84.12375	84.12625
41	633.25	633.24	633.26	679.00	84.875	84.87375	84.87625
42	639.25	639.24	639.26	685.00	85.625	85.62375	85.62625
43	645.25	645.24	645.26	691.00	86.375	86.37375	86.37625

Note: Because of possible FCC assigned offset, check for the assigned Carrier Frequency as written on License.

UHF Channels NTSC Standard IF, 45.75 MHz							
Visual Carrier Frequency (MHz)				L.O. (MHz)	Crystal Frequency (MHz)		
Channel	Nominal	Minus	Plus	Nominal	Nominal	Minus	Plus
44	651.25	651.24	651.26	697.00	87.125	87.12375	87.12625
45	657.25	657.24	657.26	703.00	87.875	87.87375	87.87625
46	663.25	663.24	663.26	709.00	88.625	88.62375	88.62625
47	669.25	669.24	669.26	715.00	89.375	89.37375	89.37625
48	675.25	675.24	675.26	721.00	90.125	90.12375	90.12625
49	681.25	681.24	681.26	727.00	90.875	90.87375	90.87625
50	687.25	687.24	687.26	733.00	91.625	91.62375	91.62625
51	693.25	693.24	693.26	739.00	92.375	92.37375	92.37625
52	699.25	699.24	699.26	745.00	93.125	93.12375	93.12625
53	705.25	705.24	705.26	751.00	93.875	93.87375	93.87625
54	711.25	711.24	711.26	757.00	94.625	94.62375	94.62625
55	717.25	717.24	717.26	763.00	95.375	95.37375	95.37625
56	723.25	723.24	723.26	769.00	96.125	96.12375	96.12625
57	729.25	729.24	729.26	775.00	96.875	96.87375	96.87625
58	735.25	735.24	735.26	781.00	97.625	97.62375	97.62625
59	741.25	741.24	741.26	787.00	98.375	98.37375	98.37625
60	747.25	747.24	747.26	793.00	99.125	99.12375	99.12625
61	753.25	753.24	753.26	799.00	99.875	99.87375	99.87625
62	759.25	759.24	759.26	805.00	100.625	100.62375	100.62625
63	765.25	765.24	765.26	811.00	101.375	101.37375	101.37625
64	771.25	771.24	771.26	817.00	102.125	102.12375	102.12625
65	777.25	777.24	777.26	823.00	102.875	102.87375	102.87625
66	783.25	783.24	783.26	829.00	103.625	103.62375	103.62625
67	789.25	789.24	789.26	835.00	104.375	104.37375	104.37625
68	795.25	795.24	795.26	841.00	105.125	105.12375	105.12625
69	801.25	801.24	801.26	847.00	105.875	105.87375	105.87625
70	807.25	807.24	807.26	853.00	106.625	106.62375	106.62625

Note: Because of possible FCC assigned offset, check for the assigned Carrier Frequency as written on License.

UHF Frequency Assignments				
Channel Number	Bandwidth (MHz)	Video (MHz)	Color (MHz)	Audio (MHz)
14	470-476	471.25	474.83	475.75
15	476-482	477.25	480.83	481.75
16	482-488	483.25	486.83	487.75
17	488-494	489.25	492.83	493.75
18	494-500	495.25	498.83	499.75
19	500-506	501.25	504.83	505.75
20	506-512	507.25	510.83	511.75
21	512-518	513.25	516.83	517.75
22	518-524	519.25	522.83	523.75
23	524-530	525.25	528.83	529.75
24	530-536	531.25	534.83	535.75
25	536-542	537.25	540.83	541.75
26	542-548	543.25	546.83	547.75
27	548-554	549.25	552.83	553.75
28	554-560	555.25	558.83	559.75
29	560-566	561.25	564.83	565.75
30	566-572	567.25	570.83	571.75
31	572-578	573.25	576.83	577.75
32	578-584	579.25	582.83	583.75
33	584-590	585.25	588.83	589.75
34	590-596	591.25	594.83	595.75
35	596-602	597.25	600.83	601.75
36	602-608	603.25	606.83	607.75
37	608-614	609.25	612.83	613.75
38	614-620	615.25	618.83	619.75
39	620-626	621.25	624.83	625.75
40	626-632	627.25	630.83	631.75
41	632-638	633.25	636.83	637.75
42	638-644	639.25	642.83	643.75
43	644-650	645.25	648.83	649.75

Note: Because of possible FCC assigned offset, check for the assigned Carrier Frequency as written on License.

UHF Frequency Assignments				
Channel Number	Bandwidth (MHz)	Video (MHz)	Color (MHz)	Audio (MHz)
44	650-656	651.25	654.83	655.75
45	656-662	657.25	660.83	661.75
46	662-668	663.25	666.83	667.75
47	668-674	669.25	672.83	673.75
48	674-680	675.25	678.83	679.75
49	680-686	681.25	684.83	685.75
50	686-692	687.25	690.83	691.75
51	692-698	693.25	696.83	697.75
52	698-704	699.25	702.83	703.75
53	704-710	705.25	708.83	709.75
54	710-716	711.25	714.83	715.75
55	716-722	717.25	720.83	721.75
56	722-728	723.25	726.83	727.75
57	728-734	729.25	732.83	733.75
58	734-740	735.25	738.83	739.75
59	740-746	741.25	744.83	745.75
60	746-752	747.25	750.83	751.75
61	752-758	753.25	756.83	757.75
62	758-764	759.25	762.83	763.75
63	764-770	765.25	768.83	769.75
64	770-776	771.25	774.83	775.75
65	776-782	777.25	780.83	781.75
66	782-788	783.25	786.83	787.75
67	788-794	789.25	792.83	793.75
68	794-800	795.25	798.83	799.75
69	800-806	801.25	804.83	805.75
70	806-812	807.25	810.83	811.75

dBm, dBw, dBmV, dB μ V, & VOLTAGE EXPRESSED IN WATTS

50 Ohm System

WATTS	PREFIX	dBm	dBw	dBmV	dB μ V	VOLTAGE
1,000,000,000,000	1 TERAWATT	+150	+120			
100,000,000,000	100 GIGAWATTS	+140	+110			
10,000,000,000	10 GIGAWATTS	+130	+100			
1,000,000,000	1 GIGAWATT	+120	+99			
100,000,000	100 MEGAWATTS	+110	+80			
10,000,000	10 MEGAWATTS	+100	+70			
1,000,000	1 MEGAWATT	+90	+60			
100,000	100 KILOWATTS	+80	+50			
10,000	10 KILOWATTS	+70	+40			
1,000	1 KILOWATT	+60	+30			
100	1 HECTROWATT	+50	+20			
50		+47	+17			
20		+43	+13			
10	1 DECAWATT	+40	+10			
1	1 WATT	+30	0	+77	+137	7.07V
0.1	1 DECIWATT	+20	-10	+67	+127	2.24V
0.01	1 CENTIWATT	+10	-20	+57	+117	0.707V
0.001	1 MILLIWATT	0	-30	+47	+107	224mV
0.0001	100 MICROWATTS	-10	-40			
0.00001	10 MICROWATTS	-20	-50			
0.000001	1 MICROWATT	-30	-60			
0.0000001	100 NANOWATTS	-40	-70			
0.00000001	10 NANOWATTS	-50	-80			
0.000000001	1 NANOWATT	-60	-90			
0.0000000001	100 PICOWATTS	-70	-100			
0.00000000001	10 PICOWATTS	-80	-110			
0.000000000001	1 PICOWATT	-90	-120			

TEMPERATURE CONVERSION

$$^{\circ}\text{F} = 32 + [(9/5) ^{\circ}\text{C}]$$

$$^{\circ}\text{C} = [(5/9) (^{\circ}\text{F} - 32)]$$

USEFUL CONVERSION FACTORS

TO CONVERT FROM	TO	MULTIPLY BY
mile (US statute)	kilometer (km)	1.609347
inch (in)	millimeter (mm)	25.4
inch (in)	centimeter (cm)	2.54
inch (in)	meter (m)	0.0254
foot (ft)	meter (m)	0.3048
yard (yd)	meter (m)	0.9144
mile per hour (mph)	kilometer per hour(km/hr)	1.60934
mile per hour (mph)	meter per second (m/s)	0.44704
pound (lb)	kilogram (kg)	0.4535924
gallon (gal)	liter	3.7854118
U.S. liquid (One U.S. gallon equals 0.8327 Canadian gallon)		
fluid ounce (fl oz)	milliliters (ml)	29.57353
British Thermal Unit per hour (Btu/hr)	watt (W)	0.2930711
horsepower (hp)	watt (W)	746

NOMENCLATURE OF FREQUENCY BANDS

FREQUENCY RANGE	DESIGNATION
3 to 30 kHz	VLF - Very Low Frequency
30 to 300 kHz	LF - Low Frequency
300 to 3000 kHz	MF - Medium Frequency
3 to 30 MHz	HF - High Frequency
30 to 300 MHz	VHF - Very High Frequency
300 to 3000 MHz	UHF - Ultrahigh Frequency
3 to 30 GHz	SHF - Superhigh Frequency
30 to 300 GHz	EHF - Extremely High Frequency

LETTER DESIGNATIONS FOR UPPER FREQUENCY BANDS

LETTER	FREQ. BAND
L	1000 - 2000 MHz
S	2000 - 4000 MHz
C	4000 - 8000 MHz
X	8000 - 12000 MHz
Ku	12 - 18 GHz
K	18 - 27 GHz
Ka	27 - 40 GHz
V	40 - 75 GHz
W	75 - 110 GHz

ABBREVIATIONS/ACRONYMS

AC	Alternating Current	PCB	Printed circuit board
AFC	Automatic Frequency Control	QAM	Quadrature Amplitude Modulation
ALC	Automatic Level Control		
AM	Amplitude modulation		
AGC	Automatic Gain Control		
AWG	American wire gauge		
BER	Bit Error Rate		
BW	Bandwidth		
DC	Direct Current		
D/A	Digital to analog		
dB	Decibel		
dBm	Decibel referenced to 1 milliwatt		
dBmV	Decibel referenced to 1 millivolt		
dBw	Decibel referenced to 1 watt		
FEC	Forward Error Correction		
FM	Frequency modulation		
Hz	Hertz		
ICPM	Incidental Carrier Phase Modulation		
I/P	Input		
IF	Intermediate Frequency		
LED	Light emitting diode		
LSB	Lower Sideband		
MPEG	Motion Pictures Expert Group		
O/P	Output		
PLL	Phase Locked Loop		

RETURN LOSS VS. VSWR

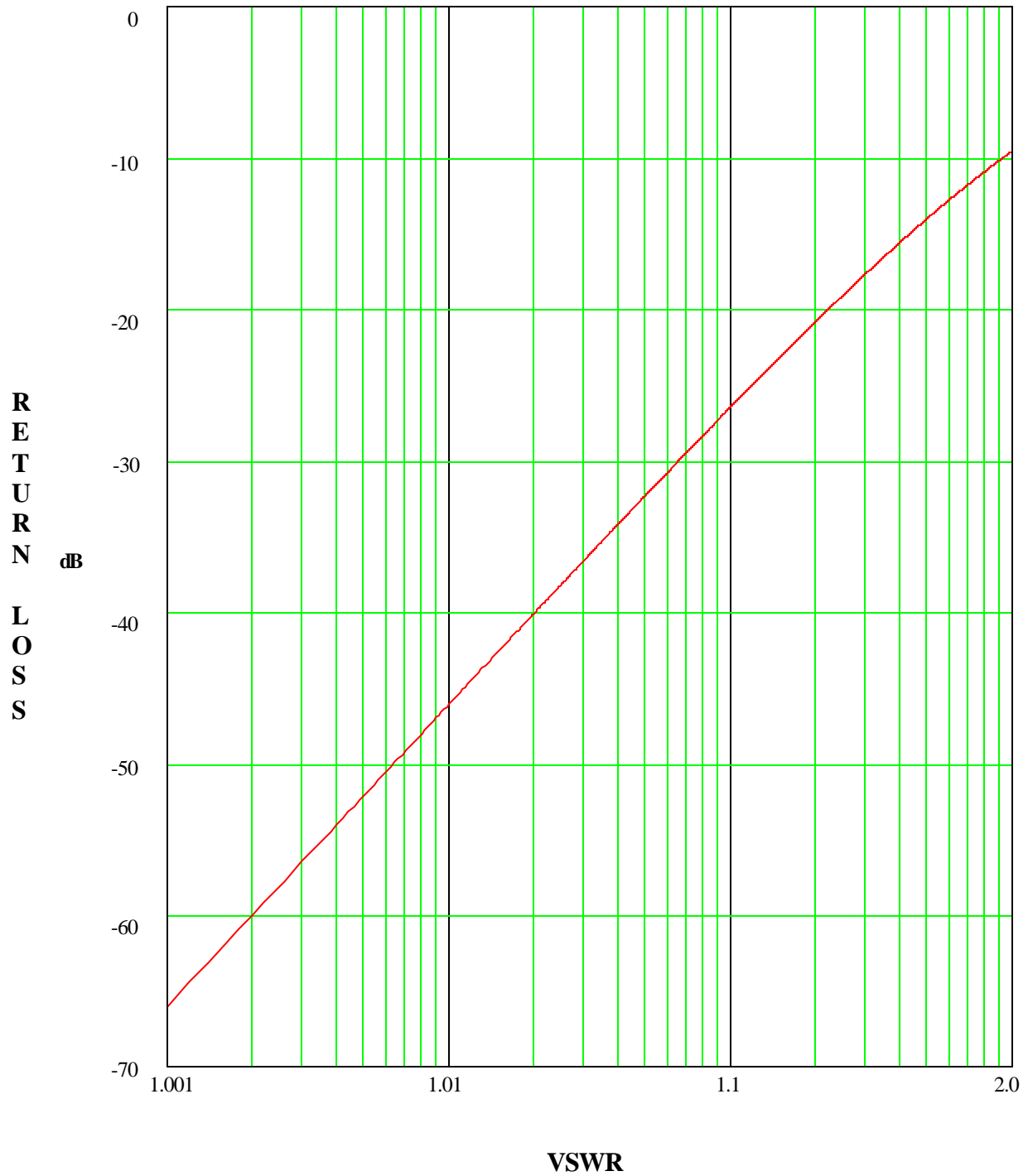

Chapter 2 System Description & Remote Control Connections

The Innovator LX Series of drivers/translators are complete 10W to 100W analog UHF translators that operate at nominal visual output power of 10 to 100 watts peak sync and an aural output power of 1 to 10 watts at an A/V ratio of 10dB, 10% sound or .5 to 5 watts at 13 dB, 5% sound.

2.1 System Overview

The Innovator LX Series translator is made up of a Receiver Tray and an exciter amplifier chassis assembly. The modules and assemblies that make up the translator are listed in Table 2-1.

Table 2-1: Innovator LX Series Translator Trays and Assemblies

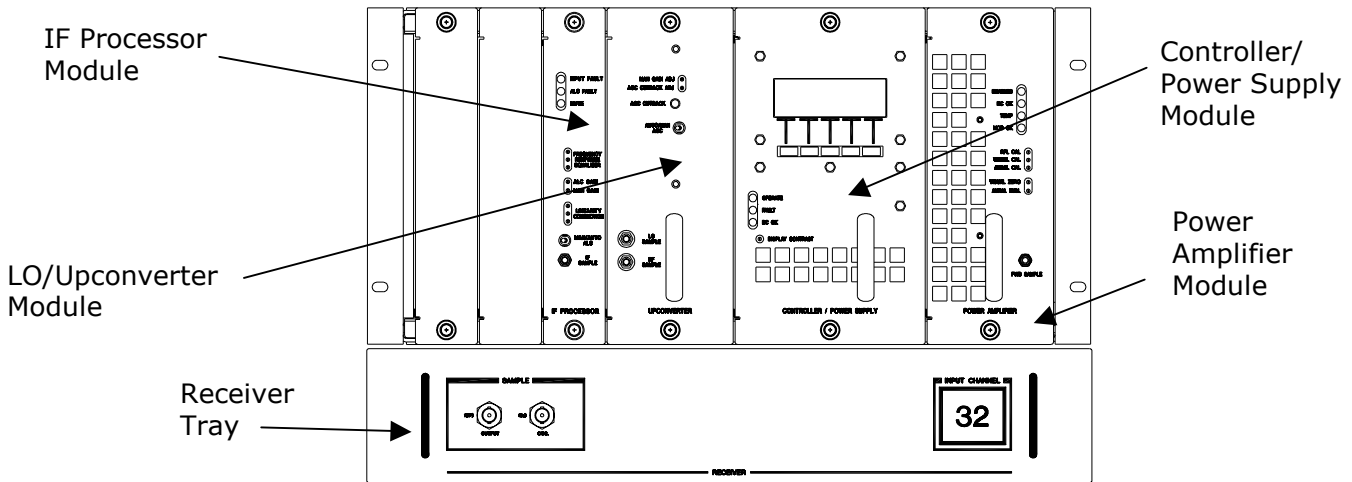

ASSEMBLY DESIGNATOR	TRAY/ASSEMBLY NAME	PART NUMBER
	Receiver Tray	1265-1100
A3	IF Processor Module	1301938
A4	Control & Monitoring/Power Supply Module	1301936
A5	LO/Upconverter Module	1301930
A6	Power Amplifier Module, 100 Watt Translator	1301923
A11	Backplane Board	1301941
A12	Switch Board	1527-1406
A20	LCD Display Board	

**2.1.1 8 Receiver Tray (1265-1100;
Appendix B)**



The Receiver Tray receives a VHF or UHF Channel input at Jack (J1) and converts it to an internally diplexed Visual + Aural IF Output (+0 dBm) at J4. The Visual + Aural IF output of the Receiver Tray at J4 is fed to J6 the IF Input Jack of the exciter.

RECEIVER TRAY	INPUT LEVEL: -61 dBm to -16dBm OUTPUT LEVEL: 0 dBm POWER REQUIREMENTS: 110 or 220 VAC
------------------	---

Table 2-5. Receiver Samples

SAMPLE	DESCRIPTION
Front panel sample - f (IF)	Sample of the IF output
Front panel sample - f (s)	Sample of the channel oscillator

Exciter Amplifier Chassis Assembly

All of the modules except the power amplifier module and the power supply section, located in the Control & Monitoring/Power Supply Module, plug

directly into a backplane board, which provides module to module interconnection as well as interconnection to remote command and control connectors.

2.1.2 (A3) IF Processor Module Assembly (1301938; Appendix B)



A3 IF PROCESSING MODULE	IF INPUT: 44MHz, (6MHz BW)
	INPUT LEVEL: -2 TO +2 dBm PK SYNC.
	MODULATOR & RECEIVER
	INPUT RETURN LOSS: > 15dB
	IF OUTPUT LEVEL: -10dBm TO -0dBm PEP
	IF SAMPLE LEVEL: -21dB (HI GAIN)
	POWER REQUIREMENTS: +12V @ 800mA
	-12V @ 100mA

The (A3) IF Processor Assembly contains the IF Processor Board (1301977). The IF Processor provides pre-correction to ensure broadcast quality output signal. The pre-correction consists of amplitude linearity correction, Incidental Carrier Phase Modulation (ICPM) correction and frequency response correction.

The IF Processor module is configured either for an analog or digital system. Pin 13C of the IF Processor module is grounded in analog systems and left not connected in digital systems. An IF Processor Interlock signal is used to report the presence of the IF Processor module to the Control Monitoring board. If the IF Processor interlock signal is not present, the Innovator LX 100 Watt Translator/Exciter Driver RF output is Muted (turned off). If an analog IF Processor module is installed and the Modulation Present signal is not true, the Innovator LX 100 Watt Translator / Exciter Driver output is Muted (turned off).

The Control & Monitoring/Power Supply module uses the IF Processor module for System output power control. Through the front panel display or a remote interface, an operator can set the translator's RF output power. The range of RF power adjustment is between 0%

(full off) and 105% (full power plus). A front panel IF Processor module potentiometer sets the upper limit of RF power at 120%. The system's Control Monitoring board compares the RF Power Monitoring module RF power level with the desired level and uses the IF Power Control PWM line to correct for errors.

In digital systems, a digital level control (DLC) voltage is generated on the IF Processor module and sent to an external digital modulator (DT1C or DT2B). RF power control is implemented by changing the DLC voltage provided to the external digital modulator. The 'RF High' potentiometer sets the upper adjusted range of RF control circuit output to 120%.

The IF Processor module provides a reference ALC voltage to the system's Upconverter. When the ALC voltage decreases, the Upconverter automatically lowers the system output power through the AGC circuits.

The IF Processor module has a front panel switch to select Auto or Manual ALC. When Manual ALC is selected, the reference ALC voltage is set by a front panel potentiometer. In this condition, the RF power level control circuit is removed from use. When the ALC select switch is changed to Auto, the RF power level control circuit will start at low power and increase the RF output until the desired output power is attained.

The IF Processor module Modulation Present signal is monitored. If the modulation level is too low or non-existent, a Modulation Present fault is reported to the Control Monitoring board. When the controller detects this fault, it can be set to Automatically Mute the translator or in Manual mode the translator will continue to operate at 25% output.

The IF Processor module Input Signal level is monitored. If the signal level is too low or non-existent, an Input fault is

reported on the Control Monitoring board. When the IF Processor board detects an Input Signal fault it

automatically Mutes the translator. The system controller does not Mute on an IF Processor Input fault.

Table 2-6. IF Processor Front Panel Switch

SWITCH	FUNCTION
MAN/AUTO ALC	When Manual ALC is selected, the reference ALC voltage is set by the ALC Gain front panel potentiometer. When Auto ALC is selected, the IF level control circuit will automatically increase the IF output until the desired output power is attained.

Table 2-7. IF Processor Front Panel Status Indicators

LED	FUNCTION
INPUT FAULT (Red)	When lit it indicates that there is a loss of the IF Input signal to the IF Processor. Translator can be set to Mute on an IF Input Fault.
ALC Fault (Red)	When lit it indicates that the required gain to produce the desired output power level has exceeded the operational range of the ALC circuit. The LED will also be lit when ALC is in Manual.
MUTE (Red)	When lit it indicates that the IF input signal is cut back but the enable to the Power Supply is present and the +32 VDC remains on.

Table 2-8. IF Processor Front Panel Control Adjustments

POTENTIOMETERS	DESCRIPTION
FREQUENCY RESPONSE EQUALIZER	These three variable resistors, R103, R106 & R274, adjust the depth of gain for the three stages of frequency response correction.
ALC GAIN	Adjusts the gain of the translator when the translator is in the Auto ALC position.
MAN GAIN	Adjusts the gain of the translator when the translator is in the Manual ALC position.
LINEARITY CORRECTION	These three variable resistors adjust the threshold cut in for the three stages of linearity pre-correction. R211 and R216, the top two pots, are adjusted to correct for in phase amplitude distortions. R 231, the bottom pot, is adjusted to correct for quadrature phase distortions.

Table 2-9. IF Processor Front Panel Sample

SMA CONNECTOR	DESCRIPTION
IF SAMPLE	Sample of the pre-corrected IF output of the IF Processor

2.1.3 (A5) LO/Upconverter Module Assembly, Digital (1301954; Appendix B)



A5 LO/UPCONVERTER MODULE	IF INPUT: 41–47 MHz
	INPUT RETURN LOSS: 18dB MIN @ 41–47 MHz
	INPUT LEVEL: –8dBm – 0dBm PK SYNC.
	CONVERSION GAIN: 0 ±1.5dB
	RF OUTPUT: 470 – 860 MHz
	10MHz INPUT LEVEL: 0 TO +6dBm
	LO OUTPUT LEVEL: 0 TO +6dBm
	LO TUNING STEP SIZE: 500kHz
	POWER REQUIREMENTS: +12V @ 400mA
	–12V @ 50mA

The (A5) LO/Upconverter Module Assembly contains a front panel LED display board (1303033), a UHF Filter (1007-1101), a UHF Generator Board (1585-1265) and a LO/Upconverter Assembly (1303039). The LO/Upconverter Assembly contains the LO/Upconverter Board (1302132).

The Innovator LX Upconverter converts an IF input signal to a RF output signal on the desired channel frequency using a high stability oven controlled oscillator with very low phase noise and an Automatic Level Control (ALC) for stable output signal level.

Several control voltages are used for translator power control. Automatic gain control (AGC) circuits set the RF output level of the translator system.

AGC #1 is provided by the 50 Watt Translator/Exciter Driver Power Amplifier module. This voltage is used by the Upconverter to maintain a constant RF output level at the Power Amplifier module output. If this voltage exceeds 0.9 VDC, the system is in an over-drive condition. The 0.9 VDC over-driver threshold is set by a front panel

Upconverter module potentiometer. When an over-drive condition is detected, the Upconverter module reduces its RF output level. For values less than 0.9 VDC, the Upconverter uses the AGC #1 voltage for automatic gain control by setting its RF output to maintain AGC #1 equal to the AGC voltage set by another front panel potentiometer. When the Upconverter is set for manual gain, the RF output of the Upconverter is set by the front panel AGC potentiometer. In manual gain operation, the AGC #1 feedback voltage from the PA is not used to adjust the RF level unless an over-drive condition is detected.

AGC #2 is provided by each of the optional external amplifier modules. Diodes are used in each of the external amplifier forward power circuits to capture the highest detected sample voltage. This voltage is used by the Upconverter to maintain a constant RF output of the system. As with AGC #1, the Upconverter module reduces its RF output level if AGC #2 is too high. AGC #1 and AGC #2 are diode ORed together in the Upconverter gain circuit. Both AGC voltages are first reduced by an on-board potentiometer before being amplified. If an over-drive condition does not exist, the higher of the two AGC voltages is used to control the Upconverter gain circuit.

An AFC Voltage is generated to control the VCXO of the UHF Generator portion of the Upconverter module. The typical AFC voltage is 1.5 VDC but it can be as high as +5 VDC.

The Upconverter can operate on either its internal 10 MHz source or on a 10 MHz external reference signal. When an external 10 MHz source is present on J10, it is automatically selected. An external reference present signal is provided to the controller for display purposes. The selected 10 MHz signal from the Upconverter is buffered then sent to the backplane on two ports. One

port is sent to the Modulator module, if present, and the other is routed to a BNC connector (J11) on the backplane for a system 10 MHz output signal.

A National Semiconductor frequency synthesizer IC is used in the frequency conversion of the IF signal to a RF signal. The frequency synthesizer IC uses a 10MHz reference frequency for signal conversion. Typically the IF input frequency is 45.75 MHz for analog system and 44 MHz for DTV. To obtain different output RF frequencies, the synthesizer IC is serial programmed by the Control Monitoring board. The part is programmed to use a 5 kHz phase detection frequency. With a 10 MHz input signal, the R counter is set to 2000. With these settings the N counter is set to the desired LO frequency in kHz

/ 5 kHz. The maximum LO frequency setting with these parameters is 1310.715 MHz.

Example:

For a Frequency RF Out = 517.125 MHz,
 $N = 517125 \text{ kHz} / 5 \text{ kHz} = 103425$

An Upconverter PLL Lock indicator is used to insure that the frequency control circuits are operating properly. When the Upconverter PLL is locked, the frequency synthesizer IC is programmed and the Power Amplifier module(s) can be enabled.

The RF output of the LO/Upconverter Module is at J23 on the rear chassis.

Table 2-10. LO/Upconverter Front Panel Switch

SWITCH	FUNCTION
MAN/AUTO AGC	When Manual AGC is selected, the reference AGC voltage is set by the AGC Manual Gain front panel potentiometer. When Auto AGC is selected, the RF power level control circuit will automatically increase the RF output until the desired output power is attained.

Table 2-11. LO/Upconverter Front Panel Status Indicator

LED	FUNCTION
AGC CUTBACK (Red)	When lit it indicates that the required gain to produce the desired output power level has exceeded the level set by the AGC Cutback (Override) adjust. Translator will cut back power to 25%

Table 2-12. LO/Upconverter Front Panel Control Adjustments

POTENTIOMETERS	DESCRIPTION
MAN GAIN ADJ	Adjusts the gain of the translator when the translator is in the Manual AGC position.
AGC CUTBACK ADJ (AGC OVERRIDE)	Adjusts the point at which the translator will cut back in power when the Translator is in the Auto AGC position.

Table 2-13. LO/Upconverter Front Panel Samples

SMA CONNECTOR	DESCRIPTION
LO SAMPLE	Sample of the LO signal to the Upconverter as generated by the UHF Generator Board.
RF SAMPLE	Sample of the On Channel RF Output of the Upconverter

**2.1.4 (A4) Control & Monitoring/
Power Supply Module Assembly
(1301936; Appendix B)**



The (A4) Control & Monitoring/Power Supply Assembly is made up of a Control Board (1302021), a Power Protection Board (1302837) and a Switch Board (1527-1406). The Assembly also contains a switching power supply that provides ± 12 VDC to the rest of the modules in the chassis and +32 VDC to the Power Amplifier module.

The Assembly provides all translator control and monitoring functions. The Front panel LCD allows monitoring of system parameters, including forward and reflected power, transistor currents, module temperatures and power supply voltages.

A4 CONTROL/ MONITORING MODULE	POWER REQUIREMENTS: +12V @ 250mA -12V @ 50mA
A4-A1 POWER SUPPLY	AC INPUT LEVEL: 100-240VAC @ 10A 50/60/400Hz DC OUTPUT LEVEL: +32V @ 15A +12V @ 8A -12V @ 4A

Table 2-14. Controller/Power Supply Display

DISPLAY	FUNCTION
LCD	A 4 x 20 display providing a four-line readout of the internal functions, external inputs, and status. See Chapter 3, Controller/Power Supply Display Screens, for a listing of displays.

Table 2-15. Controller/Power Supply Status Indicator

LED	FUNCTION
OPERATE (green)	When lit it indicates that the translator is in the Operate Mode. If translator is Muted the Operate LED will stay lit, the translator will remain in Operate, until the input signal is returned.
FAULT (red or green)	Red indicates that a problem has occurred in the translator. The translator will be Muted or placed in Standby until the problem is corrected.
DC OK (red or green)	Green indicates that the switchable fuse protected DC outputs that connect to the modules in the translator are OK.

Table 2-16. Controller/Power Supply Control Adjustments

POTENTIOMETERS	DESCRIPTION
DISPLAY CONTRAST	Adjusts the contrast of the display for desired viewing of screen.

2.1.5 (A6) Power Amplifier Module Assembly, Exciter, 5W-50W Translator (1301923; Appendix B)



A6 POWER AMPLIFIER MODULE	RF INPUT/OUTPUT: 470 – 860 MHz INPUT LEVEL: +10dBm ±2dB PK SYNC. INPUT RETURN LOSS: –10dB OUTPUT LEVEL: +51dBm (120W PK SYNC) POWER REQUIREMENTS: +32V @ 15A +12V @ 0.2A –12V @ 0.5A
---------------------------------	--

The (A6) Power Amplifier Module Assembly is made up of a Coupler Board Assembly (1301949), an Amplifier Control Board (1301962), a 1 Watt Module Assembly (1302891), a TFS 40W UHF Module (1206693) and a RF Module Pallet, Philips (1300116).

The Power Amplifier Module contains Broadband LDMOS amplifiers that cover the entire UHF band with no tuning required. They amplify the RF to the 10W to 50W output power level of the translator.

The Power Amplifier of the Translator/Exciter Driver is used to amplify the RF output of the Upconverter module. A cable, located on the rear chassis, connects the RF output from the LO/Upconverter at J23 to J24 the RF input to the PA Assembly. This module contains RF monitoring circuitry for both an analog and a digital system. Control and monitoring lines to the Power Amplifier module are routed through the floating blind-mate connector of the Control & Monitoring/Power Supply module.

The 50 Watt Translator/Exciter Driver Power Amplifier module and any External Amplifier modules contain the same control and monitoring board. This board monitors RF output power, RF reflected power, the current draw of amplifier sections, the supply voltage, and the temperature of the PA heat sink.

The RF power detector circuit outputs vary with operating frequency. These circuits must be calibrated at their intended operating frequency. Front panel adjustment potentiometers are used to calibrate the following:

Table 1: Power Amplifier Calibration Adjustments in Analog Systems

- R201 Reflected Power Cal
- R202 Visual / Forward Power Cal
- R203 Aural Power Cal
- R204 Visual Offset Zero
- R205 Aural Null

In analog systems, the Aural power of an Exciter Driver Power Amplifier and the Aural power of any external amplifier will not be reported by the system Control Monitoring module. Additionally the Visual power of these amplifiers, is reported as Forward Power just like in digital systems. In analog systems, aural and visual power will only be reported for the final system RF output.

In digital systems, the Forward power of an Exciter Driver Power Amplifier and the Forward power of any external amplifier, is reported by the system Control Monitoring module.

If the Control Monitoring module is monitoring a 5-50 Watt Translator, system power is measured in the Power Amplifier module. The wired connections are transferred through the power supply connector to the backplane board on a five position header. All four positions of control board switch SW1 must be set on to

route these lines as the system's RF power signals. In systems of output power greater than 50 Watts, system power is monitored by an external module that is connected to TB31 and control board SW1 switches must be set off.

The Forward Power of the Translator/Exciter Driver Power Amplifier

module is routed to the Upconverter module as AGC #1. A system over-drive condition is detected when this value rises above 0.9 VDC. When an over-drive condition is detected, the Upconverter module reduces its RF output level. For values less than 0.9 VDC, the Upconverter uses this voltage for automatic gain.

Table 2-17. Power Amplifier Status Indicator

LED	FUNCTION
ENABLED (Green)	When lit Green, it indicates that the PA is in the Operate Mode. If a Mute occurs, the PA will remain Enabled, until the input signal is returned.
DC OK (Green)	When lit Green, it indicates that the fuse protected DC inputs to the PA module are OK.
TEMP (GREEN)	When lit Green, it indicates that the temperature of the heatsink assembly in the module is below 78°C.
MOD OK (Green)	When lit Green, it indicates that the PA Module is operating and has no faults.

Table 2-18. Power Amplifier Control Adjustments

POTENTIOMETERS	DESCRIPTION
RFL CAL	Adjusts the gain of the Reflected Power monitoring circuit
VISUAL CAL	Adjusts the gain of the Visual / Forward Power monitoring circuit
AURAL CAL	Adjusts the gain of the Aural Power monitoring circuit
VISUAL ZERO	Adjusts the offset of the Forward Power monitoring circuit
AURAL NULL	Adjusts the offset of the Forward Power monitoring circuit based on the Aural signal level..

Table 2-19. Power Amplifier Sample

DISPLAY	FUNCTION
FWD SAMPLE	RF sample of the amplified signal being sent out the module on J25.

2.1.6 RF Output Assemblies

Modulated IF from the Receiver Tray connects to the rear of the Innovator LX chassis assembly at J6, Modulated IF Input. The power amplifiers RF output jack is at a "N" connector J25, PA RF Output.

The RF output of the PA module is connected to a band-pass and trap filter and then to an output coupler assembly. The coupler assembly provides a forward

and a reflected power sample for test purposes.

2.2 Control and Status

The control and status of the exciter/amplifier Chassis assembly is found by operating the front panel display screens. Detailed information on the use of the screens is found in chapter 3.

2.2.1 Front Panel Display Screen

A 4 x 20 display located on the front of the Control & Monitoring/Power Supply Module is used in the Innovator LX translator for control of the operation and display of the operating parameters of the translator.

2.3 System Operation

When the translator is in operate, as set by the menu screen located on the Control & Monitoring Module. The IF Processor will be enabled, the mute indicator on the front panel will be extinguished. The +32 VDC stage of the Power Supply in the Control & Monitoring Module is enabled, the operate indicator on the front panel is lit and the DC OK on the front panel should also be green. The enable and DC OK indicators on the PA Module will also be turned to green.

When the translator is in standby. The IF Processor will be disabled, the mute indicator on the front panel will be red. The +32 VDC stage of the Power Supply in the Control & Monitoring Module is disabled, the operate indicator on the front panel will be extinguished and the DC OK on the front panel should remain green. The enable and indicator on the PA Module is also extinguished.

If the translator does not switch to Operate when the operate menu is switched to Operate, check that all faults are cleared and that the remote control terminal block stand-by signal is not active.

The translator can be controlled by the presence of the modulated input signal. If the input signal to the translator is lost, the translator will automatically cutback and the input fault indicator on the IF Processor module will light. When the video input signal returns, the translator will automatically return to full power and the input fault indicator will be extinguished.

2.3.1 Principles of Operation

Operating Modes

This translator is either operating or in standby mode. The sections below discuss the characteristics of each of these modes.

Operate Mode

Operate mode is the normal mode for the translator when it is providing RF power output. To provide RF power to the output, the translator will not be in mute. Mute is a special case of the operate mode where the power supply's +32 VDC section is enabled but there is no RF output power, because of a fault condition that causes the firmware to hold the IF Processor module in a mute state.

Operate Mode with Mute Condition

The translator will remain in operate mode but will be placed in mute when the following fault conditions exists in the translator.

- Upconverter is unlocked
- Upconverter module is not present
- IF Processor module is not present
- Modulator (if present) is in Aural/Visual Mute

Entering Operate Mode

Entering the operate mode can be initiated a few different ways by the translator control board. A list of the actions that cause the operate mode to be entered is given below:

- A low on the Remote Translator Operate line.
- User selects "OPR" using switches and menus of the front panel.
- Receipt of an "Operate CMD" over the serial interface.

There are several fault or interlock conditions that may exist in the translator that will prevent the translator from entering the operate mode. These conditions are:

- Power Amplifier heat sink temperature greater than 78°C.
- Translator is Muted due to conditions listed above.
- Power Amplifier Interlock is high indicating that the amplifier is not installed.

Standby Mode

The standby mode in the translator indicates that the translator's output amplifier is disabled.

Entering Standby Mode

Similar to the operate mode, the standby mode is entered various different ways. These are:

- A low on the Remote Translator Stand-By line.
- Depressing the "STB" key on selected front panel menus.
- Receipt of a "Standby CMD" over the serial interface.

Operating Frequency

The Innovator LX translator controller is designed to operate on UHF and VHF frequencies. The exact output frequency of the translator can be set to one of the standard UHF or VHF frequencies, or it can be set to a custom frequency using software set-up menus. Since RF performance of the translator requires different hardware for different frequency bands, not all frequency configurations are valid for a specific translator. Power detectors have frequency dependency, therefore detectors of power amplifiers are calibrated at their frequency of use. The detectors for System RF monitoring are also calibrated at the desired frequency of use.

Table 2-22: VHF Television Frequencies

BAND	CH #	FREQUENCY	BAND	CH #	FREQUENCY
VHF LOW	02	54-60 MHz	VHF HIGH	07	174-180 MHz
VHF LOW	03	60-66 MHz	VHF HIGH	08	180-186 MHz
VHF LOW	04	66-72 MHz	VHF HIGH	09	186-192 MHz
VHF LOW	05	76-82 MHz	VHF HIGH	10	192-198 MHz
VHF LOW	06	82-88 MHz	VHF HIGH	11	198-204 MHz
			VHF HIGH	12	204-210 MHz
			VHF HIGH	13	210-216 MHz

Table 2.23: UHF Television Frequencies

CH #	FREQUENCY	CH #	FREQUENCY	CH #	FREQUENCY
14	470-476 MHz	38	614-620 MHz	61	752-758 MHz
15	476-482 MHz	39	620-626 MHz	62	758-764 MHz
16	482-488 MHz	40	626-632 MHz	63	764-770 MHz
17	488-494 MHz	41	632-638 MHz	64	770-776 MHz
18	494-500 MHz	42	638-644 MHz	65	776-782 MHz
19	500-506 MHz	43	644-650 MHz	66	782-788 MHz
20	506-512 MHz	44	650-656 MHz	67	788-794 MHz
21	512-518 MHz	45	656-662 MHz	68	794-800 MHz
22	518-524 MHz	46	662-668 MHz	69	800-806 MHz
23	524-530 MHz	47	668-674 MHz	70	806-812 MHz

CH #	FREQUENCY	CH #	FREQUENCY	CH #	FREQUENCY
24	530-536 MHz	48	674-680 MHz	71	812-818 MHz
25	536-542 MHz	49	680-686 MHz	72	818-824 MHz
26	542-548 MHz	50	686-692 MHz	73	824-830 MHz
27	548-554 MHz	51	692-698 MHz	74	830-836 MHz
28	554-560 MHz	52	698-704 MHz	75	836-842 MHz
29	560-566 MHz	53	704-710 MHz	76	842-848 MHz
30	566-572 MHz	54	710-716 MHz	77	848-854 MHz
31	572-578 MHz	55	716-722 MHz	78	854-860 MHz
32	578-584 MHz	56	722-728 MHz	79	860-866 MHz
33	584-590 MHz	57	728-734 MHz	80	866-872 MHz
34	590-596 MHz	58	734-740 MHz	81	872-878 MHz
35	596-602 MHz	59	740-746 MHz	82	878-884 MHz
36	602-608 MHz	60	746-752 MHz	83	884-890 MHz
37	608-614 MHz				

2.4 Customer Remote Connections

The remote monitoring and operation of the translator is provided through jacks TB30 and TB31 located on the rear of the chassis assembly. If remote connections are made to the translator, they must be

made through plugs TB30 and TB31 at positions noted on the translator interconnect drawing and Table 2-25.

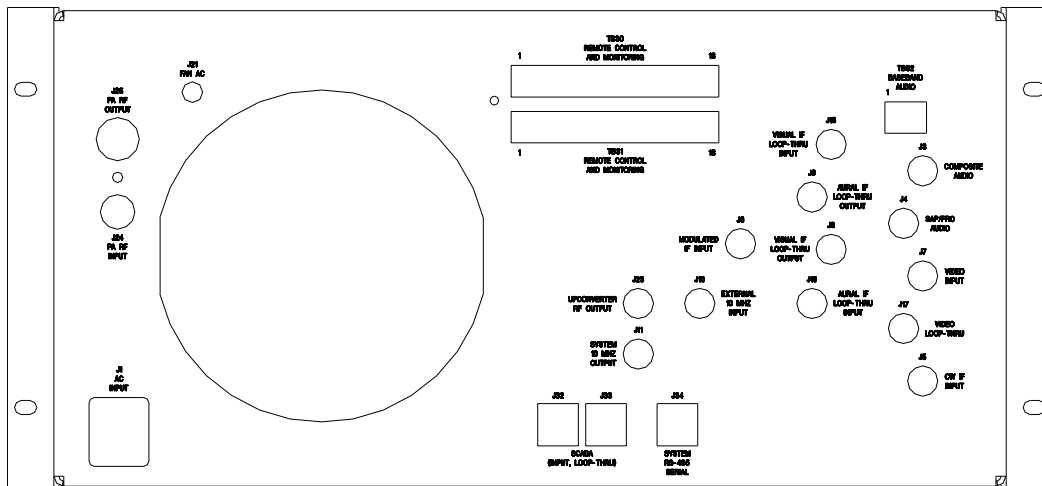

Table 2-25: Innovator LX Chassis Assembly Hard Wired Remote Interface Connections to TB30 or TB31, 18 pos. Terminal Blocks Located on the Rear of the Assembly

Signal Name	Pin Designations	Signal Type/Description
RMT Translator State	TB30-1	Discrete Open Collector Output - A low indicates that the translator is in the operate mode.
RMT Translator Interlock	TB30-2	Discrete Open Collector Output - A low indicated the translator is OK or completes a interlock daisy chain. When the translator is not faulted, the interlock circuit is completed.
RMT Translator Interlock Isolated Return	TB30-3	Ground - Configurable ground return which can be either jumpered directly to ground or it can be the "source" pin of an FET so that the translator interlock can be daisy chained with other translators. This signal does not directly interface to the microcontroller.
RMT AUX IO 1	TB30-4	Discrete Open Collector Inputs, Discrete Open Drain Outputs, or 0 - 5 VDC Analog Input - When used as an output, this line is pulled to +5 VDC with a 1.0 kΩ resistor for logic high and pulled to ground for a low. A diode allows this line to be pulled up to 12 VDC. When used as a digital input, this line considers all values over 2 Volts as high and those under 1 volt as low. As an analog input, this line is protected by a 5.1 zener diode.
RMT AUX IO 2	TB30-5	
RMT Translator Operate	TB30-6	Discrete Open Collector Input - A pull down to ground on this line indicates that the translator is to be placed into the operate mode.
RMT Translator Stand-By	TB30-7	Discrete Open Collector Input - A pull down to ground on this line indicates that the translator is to be placed into the standby mode.
RMT Power Raise	TB30-8	Discrete Open Collector Input - A pull down to ground on this line indicates that the translator power is to be raised.
RMT Power Lower	TB30-9	Discrete Open Collector Input - A pull down to ground on this line indicates that the translator power is to be lowered.
RMT System Reflect Power	TB30-10	Analog Output - 0 to 4.0 V- This is a buffered loop through of the calibrated "System Reflected Power " and indicates the translator's reflected output power. The scale factor is 25 % / 3.2V.
RMT System Visual/Forward Power	TB30-11	Analog Output - 0 to 4.0 V- This is a buffered loop through of the calibrated "System Visual/Avg. Power ". Indicates the translator's Visual / Average power. Scale factor is 100 % / 3.2V.
RMT System Aural Power	TB30-12	Analog Output - 0 to 4.0 V- This is a buffered loop through of the calibrated "System Aural Power ". Indicates the translator's forward Aural output power. The scale factor is 100 % / 3.2V.
RMT Spare 1	TB30-13	Remote connection to spare module - Use is TBD.
RMT Spare 2	TB30-14	Remote connection to spare module - Use is TBD.

Signal Name	Pin Designations	Signal Type/Description
System Reflect Power	TB31-13	Analog Input - 0 to 1.00 V- This is the input of the "System Reflected Power " indicating the translator's reflected output power. The scale factor is 25 % / 0.80V.
System Visual / Forward Power	TB31-14	Analog Input - 0 to 1.00 V- This is the input of the "System Visual / Forward Power " indicating the translator's forward Visual / Forward output power. The scale factor is 100 % / 0.80V.
System Aural Power	TB31-15	Analog Input - 0 to 1.00 V- This is the input of the "System Aural Power " indicating the translator's forward Aural output power. The scale factor is 100 % / 0.80V.
IF Processor IF Signal Select	TB31-3	Discrete Open Collector Input - A low indicates that the modulator IF source is to be used by the IF Processor module. When floating an analog IP Processor module may use the Modulated IF Input if the IF Processor sled is so configured.
IF Processor DLC Voltage	TB31-4	Analog Output - 0 to 5.00 V- This is the input of IF Processor module for digital system RF output power control.
UC AGC #2 Voltage	TB31-5	Auxiliary Analog Input - 0 to 1V- This voltage is used by the Upconverter for gain control. Linear signal with display resolution of 0.01 %. Primary signal source is J34-1.
RMT Ground	TB30-15, and 17	Ground pins available through Remote
RMT Ground	TB31-1, 2, 6 to 12, and 17	Ground pins available through Remote
RMT +12 VDC	TB30-16 TB31-16	+12 VDC available through Remote w/ 2 Amp re-settable fuse
RMT -12 VDC	TB30-18 TB31-18	-12 VDC available through Remote w/ 2 Amp re-settable fuse

J3 Remote Connections

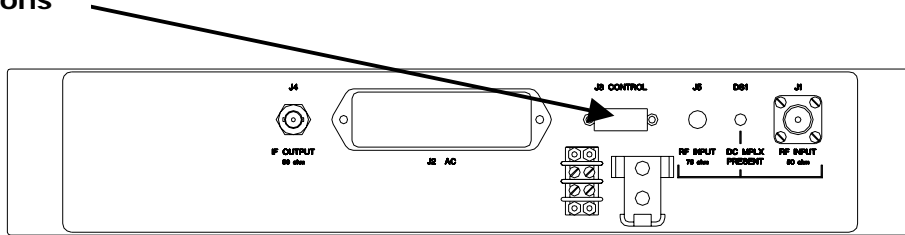

Table 2-26. Receiver Tray hard wired Remote Connections thru J3 a 15-pin, D-Connector located on the rear of the tray

Signal Name	Pin Designations	Signal Type/Description
ALC Voltage (+)	J3-3	ALC Voltage output
ALC Voltage (-)	J3-4	ALC Voltage output ground return

Chapter 3

Site Considerations, Installation and Setup Procedures

There are special considerations that need to be taken into account before the Innovator LX Series translator can be installed. For example, if the installation is completed during cool weather, a heat-related problem may not surface for many months, suddenly appearing during the heat of summer. This section provides planning information for the installation and set up of the translator.

3.1 Site Considerations

The translator requires an AC input line of 117 VAC @ 5 amps for the 10W translator or 117 VAC @ 10 amps for the 100W Translator.

The Innovator LX Series Translators are designed and built to provide long life with a minimum of maintenance. The environment in which they are placed is important and certain precautions must be taken. The three greatest dangers to the translator are heat, dirt, and moisture. Heat is usually the greatest problem, followed by dirt, and then moisture. Over-temperature can cause heat-related problems such as thermal runaway and component failure. Each amplifier module in the translator contains a thermal interlock protection circuit that will shut down that module until the temperature drops to an acceptable level.

A suitable environment for the translator can enhance the overall performance and reliability of the translator and maximize revenues by minimizing downtime. A properly designed facility will have an adequate supply of cool, clean air, free of airborne particulates of any kind, and no excessive humidity. An ideal environment will require temperature in the range of 40° F to 70° F throughout the year, reasonably low humidity, and a dust-free room. It should be noted that this is rarely if ever attainable in the real world.

However, the closer the environment is to this design, the greater the operating capacity of the translator.

The fans are designed and built into the translator will remove the heat from within the modules, but additional means are required for removing this heat from the building. To achieve this, a few issues need to be resolved. The first step is to determine the amount of heat to be removed from the translator room. There are generally three sources of heat that must be considered. The first and most obvious is the heat from the translator itself. This amount can be determined for a 100W translator by subtracting the average power to the antenna (69.5 watts) from the AC input power (675 watts) and taking this number in watts (605.5) and then multiplying it by 3.41. This gives a result of 2,065, the BTUs to be removed every hour. 12,000 BTUs per hour equals one ton. Therefore, a 1/4-ton air conditioner will cool a 100W translator.

The second source of heat is other equipment in the same room. This number is calculated in the same way as the equation for BTUs. The third source of heat is equally obvious but not as simple to calculate. This is the heat coming through the walls, roof, and windows on a hot summer day. Unless the underside is exposed, the floor is usually not a problem. Determining this number is usually best left up to a qualified HVAC technician. There are far too many variables to even estimate this number without reviewing the detailed drawings of the site that show all of the construction details. The sum of these three sources is the bulk of the heat that must be removed. There may be other sources of heat, such as personnel, and all should be taken into account.

Now that the amount of heat that must be removed is known, the next step is to determine how to accomplish this. The options are air conditioning, ventilation, or a combination of the two. Air conditioning is always the preferred method and is the only way to create anything close to an ideal environment.

Ventilation will work quite well if the ambient air temperature is below 100° F, or about 38° C, and the humidity is kept at a reasonable level. In addition, the air stream must be adequately filtered to ensure that no airborne particulates of any kind will be carried into the translator. The combination of air conditioning for summer and ventilation during the cooler months is acceptable when the proper cooling cannot be obtained through the use of ventilation alone and using air conditioning throughout the year is not feasible.

Caution: The use of air conditioning and ventilation simultaneously is not recommended. This can cause condensation in the translators.

The following precautions should be observed regarding air conditioning systems:

1. Air conditioners have an ARI nominal cooling capacity rating. In selecting an air conditioner, do not assume that this number can be equated to the requirements of the site. Make certain that the contractor uses the actual conditions that are to be maintained at the site in determining the size of the air conditioning unit. With the desired conditioned room temperature under 80° F, the unit must be derated, possibly by a substantial amount.
2. Do not have the air conditioner blowing directly onto the translator. Under certain conditions, condensation may

occur on, or worse in, the translator.

3. Do not separate the front of the translator from the back with the thought of air conditioning only the front of the unit. Cooling air is drawn in at the front of all translators and in the front and back of others. Any attempt to separate the front of the translator from the rear of the unit will adversely affect the flow of cooling air.
4. Interlocking the translator with the air conditioner is recommended to keep the translator from operating without the necessary cooling.
5. The periodic cleaning of all filters is a must.

When using ventilation alone, the following general statements apply:

1. The blower, with attendant filters, should be on the inlet, thereby pressurizing the room and preventing dirt from entering the translator.
2. The inlet and outlet vents should be on the same side of the building, preferably the leeward side. As a result, the pressure differential created by wind will be minimized. Only the outlet vent may be released through the roof.
3. The inlet and outlet vents should be screened with 1/8-inch hardware cloth (preferred) or galvanized hardware cloth (acceptable).
4. Cooling air should enter the room as low as practical but in no case higher than four feet above the floor. The inlet must be located where dirt, leaves, snow, etc., will not be carried in with the cooling air.

-
- | | |
|---|--|
| <p>5. The exhaust should be located as high as possible. Some ducting is usually required to insure the complete flushing of heated air with no stagnant areas.</p> <p>6. The filter area must be large enough to insure a maximum air velocity of 300 feet per minute through the filter. This is not a conservative number but a never-exceed number. In a dusty or remote location, this number should be reduced to 150 CFM.</p> <p>7. The inlet and outlet(s) must have automatic dampers that close any time the ventilation blower is off.</p> <p>8. In those cases in which translators are regularly off for a portion of each day, a temperature-differential sensor that controls a small heater must be installed. This sensor will monitor inside and outside temperatures simultaneously. If the inside temperature falls to within 5° F of the outside temperature, the heater will come on. This will prevent condensation when the ventilation blower comes on and should be used even in the summer.</p> <p>9. A controlled-air bypass system must be installed to prevent the temperature in the room from falling below 40° F during translator operation.</p> <p>10. The blower should have two speeds, which are thermostatically controlled, and be interlocked with the translator.</p> <p>11. The blower on high speed must be capable of moving the required volume of air into a half inch of water pressure at the required elevation. The free air delivery method must not be used.</p> | <p>12. Regular maintenance of the filters, if used, can not be overemphasized.</p> <p>13. Above 4000 feet, for external venting, the air vent on the cabinet top must be increased to an 8-inch diameter for a 1-kW translator and to a 10-inch diameter for 5-kW and 6-kW translators. An equivalent rectangular duct may be used but, in all cases, the outlet must be increased by 50% through the outlet screen.</p> <p>14. It is recommended that a site plan be submitted to Axcera for comments before installation begins.</p> <p>In calculating the blower requirements, filter size, and exhaust size, if the total load is known in watts, 2000 CFM into ½ inch of water will be required for each 5000 watts. If the load is known in BTUs, 2000 CFM into ½inch of water will be required for each 17,000 BTUs. The inlet filter must be a minimum of seven square feet, larger for dusty and remote locations, for each 5000 watts or 17,000 BTUs. The exhaust must be at least four square feet at the exhaust screen for each 5000 watts or 17,000 BTUs.</p> <p>The information presented in this section is intended to serve only as a general guide and may need to be modified for unusually severe conditions. A combination of air conditioning and ventilation should not be difficult to design (see Figure 3-1).</p> <p>System interlocking and thermostat settings should be reviewed with Axcera. As with any equipment installation, it is always good practice to consult the manufacturer when questions arise. Axcera can be contacted at (724) 873-8100</p> |
|---|--|

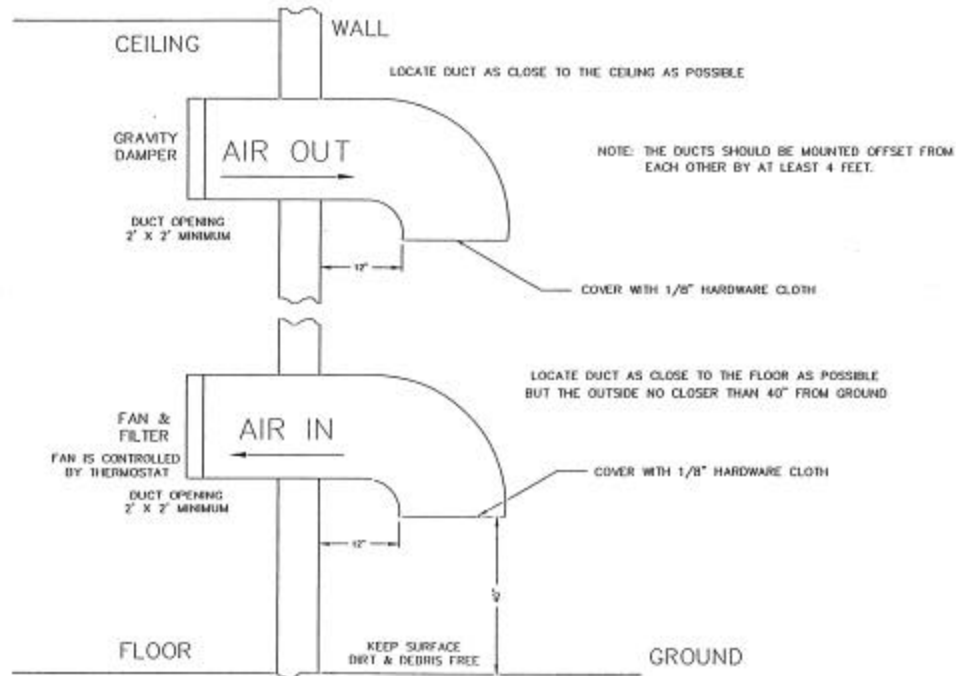

Figure 3-1. 1 kW Minimum Ventilation Configuration

3.2 Unpacking the Chassis w/modules, receiver tray, trap filter and band-pass filter assembly

Thoroughly inspect the chassis with modules and all other materials upon their arrival. Axcera certifies that upon leaving our facility the equipment was undamaged and in proper working order. The shipping containers should be inspected for obvious damage that indicates rough handling.

Remove the chassis and modules, along with the receiver tray, the trap filter and band-pass filter, from the crates and boxes.

Check for dents and scratches or broken connectors, switches, display, or connectors. Any claims against in-transit damage should be directed to the carrier. Inform Axcera as to the extent of any damage as soon as possible.

The modules are mounted to the chassis assembly with slides that are on the top and the bottom of the modules. There

are two thumb screws on the front panel that hold each of the modules in place. The receiver tray is mounted in the cabinet using Chassis Trak cabinet slides. The tray slides are on the side of the tray. Inspect the tray for any loose hardware or connectors, tightening where needed

3.3 Installing the Chassis w/modules, receiver tray, trap filter and band-pass filter assembly

The chassis assembly and receiver tray are made to mount in a standard 19" rack. The chassis assembly mounts using the four #10 clearance mounting holes on the ends. The chassis should be positioned; to provide adequate air intake into the front and the air exhaust of the fan in the rear; the ability to slide the modules out for replacement purposes; the installation of the trap filter; the band-pass filter assembly; and output transmission line. The chassis or cabinet in which it is mounted should be grounded using copper strapping material.

Normally, the receiver tray mounts below the Chassis assembly using Chassis Trak cabinet slides. The Side Rails are pre-mounted on the sides of the Tray. Install the Tray slides found in the Installation Material into the left and right side of the standard 19" Cabinet. Refer to the "Cabinet Mounting Instructions For Tray Slides" drawing below. Check that the Tray Slides are mounted in line with each other. Secure the slides by connecting them to the front and rear mounting bars using the No. 10 bolts and bar nuts provided. Insert the Tray onto the Tray

Slides and slide the Tray into the cabinet. Slowly slide the Tray in and out to verify that it does not rub against the Chassis assembly and has no restriction to free movement. Adjustment to the position of the Tray may be necessary, and is accomplished by loosening the cabinet slide mounting bolts that hold the front of the slide to the mounting frame of the Cabinet and moving the Tray up or down as needed to correct for the rubbing. Retighten after adjusting.

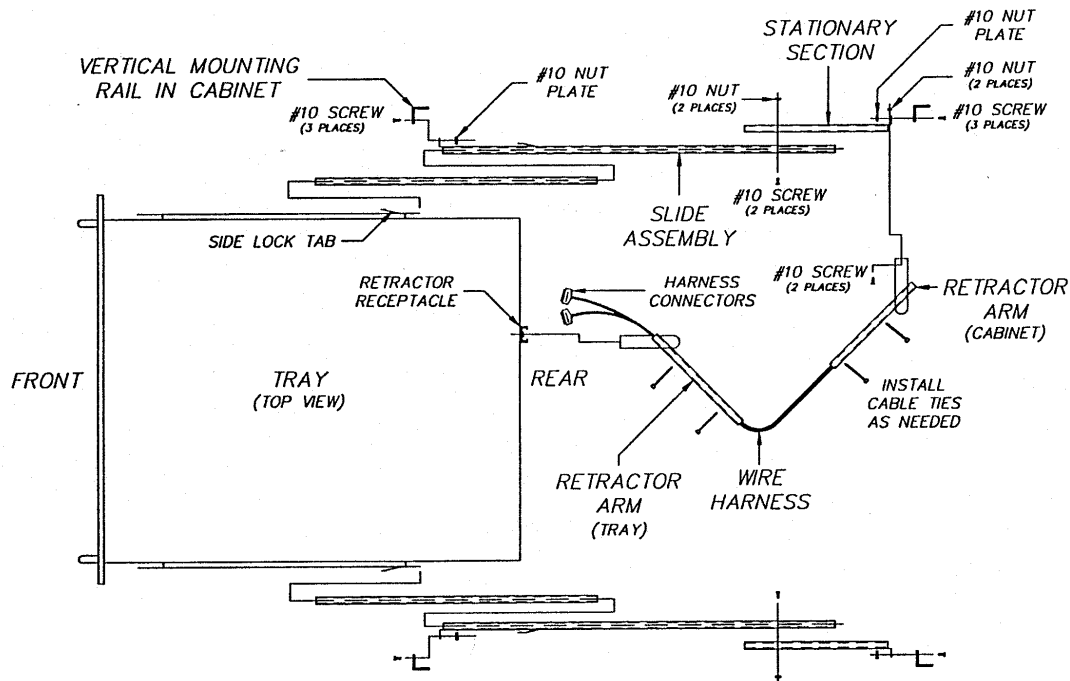

Figure 3-2. Tray Slides Cabinet Mounting Diagram

NOTE: To pull out the power amplifier module for replacement purposes, the input and output coaxial cables must first be removed from the rear of the chassis assembly.

Connect the digital mask filter and coupler assembly to the output of the chassis assembly.

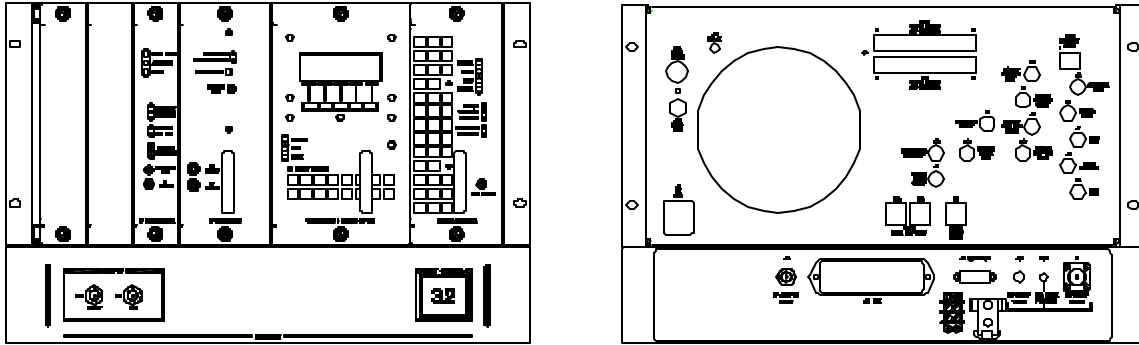

Figure 3-3. Front and Rear View Reconnection Drawing

Connect the transmission line for the antenna system to the band-pass filter output.

3.4 AC Input

The Exciter/Amplifier chassis assembly needs to be plugged into an AC outlet of 115 or 230 VAC, as set at the factory. Current requirements are 5 amps for 10W translators and 10 amps 50W translators, in order to operate. The Receiver Tray requires an AC outlet of 115 VAC or 230 VAC. The AC can be set for the Receiver Tray as follows.

FOR 115 VAC – Verify that 115 volts is indicated on the rear panel cover of the power entry module. If not, gently open the cover, remove the fuse assembly, and reinsert the assembly so that 115 volts is visible with the cover closed.

FOR 230 VAC – Verify that 230 volts is indicated on the rear panel cover of the power entry module. If not, gently open the cover, remove the fuse assembly, and reinsert the assembly so that 230 volts is visible with the cover closed.

When the AC power cord for the exciter/amplifier chassis is plugged in, the AC is always connected to the translator. There is an On/off circuit breaker located on the rear of the Receiver Tray that needs to be

switched on to apply the AC to the rest of the Tray.

This completes the unpacking and installation of the Innovator LX Series UHF television translator. Refer to the setup and operation procedures that follow before applying power to the translator.

3.5 Setup and Operation

Initially, the translator should be turned on with the RF output at the coupler assembly terminated into a dummy load of 10W or 100W depending on the power rating of the translator. If a load is not available, check that the output of the coupler assembly is connected to the antenna for your system.

3.5.1 Input Connections

The input connections to the translator are to the rear of the Receiver Tray and to the rear of the Chassis Assembly for the translator.

Refer to the tables and description that follows for detailed information.

Figure 3-4: Rear View of Innovator LX Series Driver/Translator

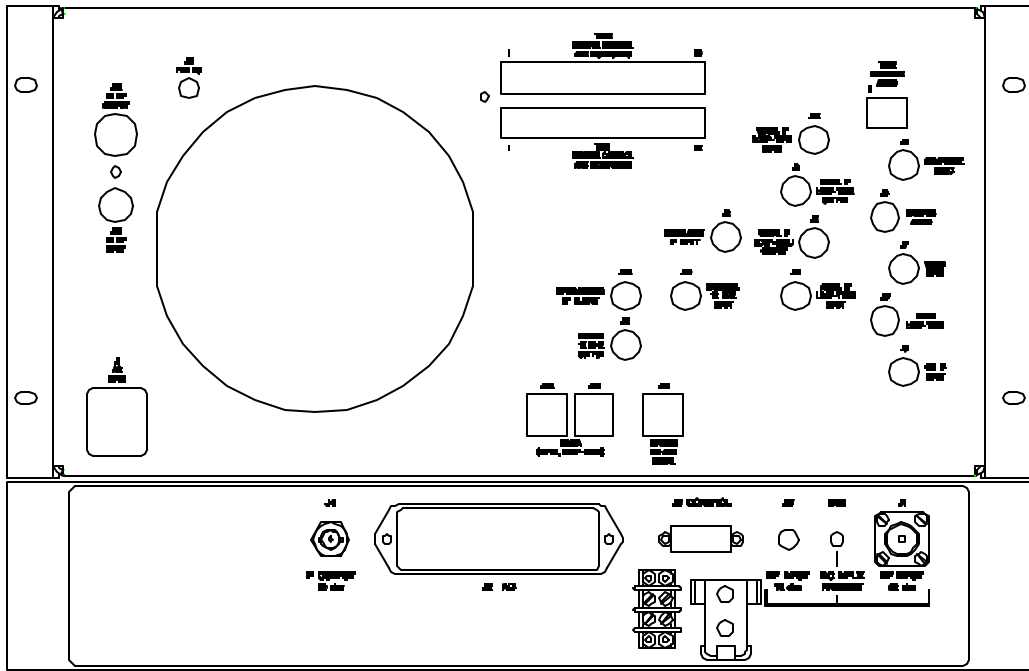

Table 3-1: Rear Chassis Connections for the Receiver Tray.

Port	TYPE	Function	Ohm
J1	N	RF Input	50
J2	IEC	AC Input	N/A
J3	15-pin D	Remote Connections	N/A
J4	BNC	IF Output	50

Table 3-2: Rear Chassis Connections for the Innovator LX Series Driver/Translator.

Port	Type	Function	Ohm
J1	IEC	AC Input	N/A
TB02	Term	Base Band Audio Input	600
J3	BNC	Composite Audio Input	75
J4	BNC	SAP / PRO Audio Input	50
J5	BNC	CW IF Input	50
J6	BNC	Modulated IF Input	50
J7	BNC	Video Input (Isolated)	75
J8	BNC	Visual IF Loop-Thru Output	50
J9	BNC	Aural IF Loop-Thru Output	50
J10	BNC	10 MHz Reference Input	50
J11	BNC	10 MHz Reference Output	50

Port	Type	Function	Ohm
J17	BNC	Video Loop-Thru (Isolated)	75
J18	BNC	Visual IF Loop-Thru Input	50
J19	BNC	Aural IF Loop-Thru Input	50
J23	BNC	Upconverter RF Output	50
J24	BNC	Power Amplifier RF Input	50
J25	N	Power Amplifier RF Output	50
TB30	Term	Remote Control & Monitoring	
TB31	Term	Remote Control & Monitoring	
J32	RJ-45	SCADA (Input / Loop-Thru)	CAT5
J33	RJ-45	SCADA (Input / Loop-Thru)	CAT5
J34	RJ-45	System RS-485 Serial	CAT5

3.5.2 Front Panel Screens for the Exciter/Amplifier Chassis Assembly

A 4 x 20 display located on the front of the Control & Monitoring/Power Supply Module is used in the Innovator LX translator for control of the operation and display of the operating parameters of the translator. Below are the display screens for the system. The ↑ and ↓

characters are special characters used to navigate up or down through the menu screens. Display text flashes on discrete fault conditions for all screens that display a fault condition.

When the translator is in operate mode, the STB menu appears. When the translator is in standby mode, the OPR menu appears.

Display Menu Screens for the Innovator LX Series Translator

Table 3-3: Menu 01 - Splash Screen #1

A	X	C	E	R	A														
1	0	3		F	R	E	E	D	O	M		D	R	I	V	E			
L	A	W	R	E	N	C	E	,		P	A	.	1	5	0	5	5		
(7	2	4)		8	7	3	-	8	1	0	0						

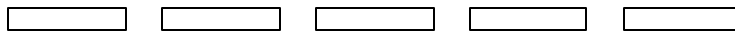

This is the first of the two translator splash screens that is shown for the first few seconds after reset.

Table 3-4: Menu 02- Splash Screen #2

I	N	N	O	V	A	T	O	R		L	U	2	0	0	0	A	L		
C	O	D	E		V	E	R	S	I	O	N		1	.	0				
F	I	R	M	W	A	R	E					1	3	0	2	1	6	4	
S	C	A	D	A		A	D	D	R	E	S	S							5

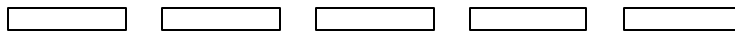

This is the second of the two translator splash screens

Table 3-5: Menu 10 - Main Screen

	F	O	R	W	A	R	D		P	W	R		1	0	0	%			
	R	E	F	L	E	C	T	E	D		P	W	R	1	.	0	%		
↑																	S	T	B
	↓																		

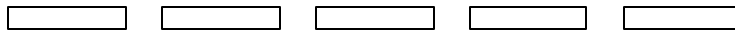

This is the default main screen of the translator. When the translator is in operate, the 'STB' characters appear allowing an operator to place the translator in stand-by. When the translator is in standby the 'STB' characters are replaced with 'OPR' and an operator can place the translator into operate by pressing the right most switch on the front panel display. If the ↓ key is activated the system changes to Menu 11. If the ↑ key is activated the system displays to Menu 13.

Table 3-6: Menu 11 - Error List Access Screen

S	Y	S	T	E	M	E	R	R	O	R	S	6					
E	R	R	O	R	L	I	S	T	D	I	S	P	L	A	Y		
↑					↓				E	N	T				S	T	B
<input type="text"/> <input type="text"/> <input type="text"/> <input type="text"/> <input type="text"/>																	

This screen of the translator shows the current number of errors and provides operator access to view the error list. This is the entry point to Menu 20. If the ↓ key is activated the system changes to Menu 12. If the ↑ key is activated the system returns to Menu 10.

Table 3-7: Menu 12 - Translator Device Data Access Screen

T	R	A	N	S	M	I	T	T	E	R	D	E	T	A	I	L	S		
↑						↓					E	N	T				S	T	B
<input type="text"/> <input type="text"/> <input type="text"/> <input type="text"/> <input type="text"/>																			

This screen of the translator allows access to various parameters of the translator system. This is the entry point to Menu 30. If the ↓ key is activated the system changes to Menu 13. If the ↑ key is activated the system returns to Menu 11.

Table 3-8: Menu 13 - Translator Configuration Access Screen

T	R	A	N	S	M	I	T	T	E	R	S	E	T	-	U	P			
↑						↓					E	N	T				S	T	B
<input type="text"/> <input type="text"/> <input type="text"/> <input type="text"/> <input type="text"/>																			

This screen of the translator allows access to various software setting of the translator system. This is the entry point to Menu 40. If the ↓ key is activated the system returns to Menu 10. If the ↑ key is activated the system returns to Menu 12.

Table 3-9: Menu 20 - Error List Display Screen

S	Y	S	T	E	M	E	R	R	O	R	S	1	/	6			
U	P	C	O	N	V	E	R	T	E	R	M	O	D	U	L	E	
I	N	T	E	R	L	O	C	K	F	A	U	L	T				
↑						↓					C	L	R	E	S	C	
<input type="text"/> <input type="text"/> <input type="text"/> <input type="text"/> <input type="text"/>																	

This screen of the translator allows access to system faults. Fault logging is stored in non-volatile memory. The translator's operating state can not be changed in this screen. The 'CLR' switch is used to clear previously detected faults that are no longer active. The ↑ key and ↓ key allow an operator to scroll through the list. The ESC switch is used to leave this screen.

Table 3-10: Menu 30 - Translator Device Details Screen

S	Y	S	T	E	M	D	E	T	A	I	L	S							
X	M	T	R	I	N	O	P	E	R	A	T	E	M	O	D	E			
P	O	W	E	R	S	U	P	P	L	Y	:	O	K						
↑					↓					←				→			E	S	C
<input type="text"/> <input type="text"/> <input type="text"/> <input type="text"/> <input type="text"/>																			

This screen of the translator allows access to translator parameters of installed devices. The system must be configured for the translator to know which devices are expected to be present. Current values for all installed devices are shown. If a module is not installed, only a "MODULE NOT PRESENT" message will be presented. The ↑ and ↓ arrows scroll through the different parameters of each device.

Table 3-11: Translator Device Parameters

System Component	Parameter	Normal	Faulted (Blinking)
Modulator (Analog Systems)	PLL CIRCUIT	LOCKED	UNLOCKED
	OUTPUT LEVEL	0 - 200 IRE	N/A
	AURAL DEVIATION	0 - 125 kHz	N/A
	CW INPUT	PRESENT	NOT USED
	STATION ID	SEND soft key	N/A
IF Processor (Analog Systems)	INPUT STATE	OK	FAULT
	MODULATION	OK	FAULT
	IF INPUT	MODULATOR or J6	N/A
	ALC LEVEL	0 - 5.00 V	N/A
	ALC MODE	AUTO or MANUAL	N/A
	DLC LEVEL	0 - 5.00 V	N/A
IF Processor (Digital Systems)	ALC LEVEL	0 - 5.00 V	N/A
	ALC MODE	AUTO or MANUAL	N/A
	DLC LEVEL	0 - 5.00 V	N/A
LO / Upconverter	PLL CIRCUIT	LOCKED	FAULT
	AFC LEVEL	0 - 5.00 V	N/A
	AGC 1 LEVEL	0 - 5.00 V	N/A
	AGC 2 LEVEL	0 - 5.00 V	N/A
	EX. 10 MHz	PRESENT or NOT USED	N/A
	LO FREQ	xxx.xxx MHz	N/A
Power Amp (In Analog Systems)	AMP STATE	ENABLED or DISABLED	N/A
	SUPPLY VOLTAGE	OK or OFF	FAULT
	VISUAL POWER	xxx%	xxx%
	AURAL POWER	xxx%	xxx%
	REFLECTED POWER	xxx%	xxx%
	AMP CURRENT 1	xx.xA	xx.xA
	AMP CURRENT 2	xx.xA	xx.xA
	AMP TEMPERATURE	xxC	xxC
CODE VERSION	x.x	N/A	
Power Amp (In Digital Systems)	AMP STATE	ENABLED or DISABLED	N/A
	SUPPLY VOLTAGE	OK or OFF	FAULT
	FORWARD POWER	xxx%	xxx%
	REFLECTED POWER	xxx%	xxx%
	AMP CURRENT 1	xx.xA	xx.xA
	AMP CURRENT 2	xx.xA	xx.xA
	AMP TEMPERATURE	xxC	xxC
	CODE VERSION	x.x	N/A
Ext. Power Supply Tray x Mod y	AMP STATE	ENABLED or DISABLED	N/A
	SUPPLY VOLTAGE	OK or OFF	FAULT
	FORWARD POWER	xxx%	xxx%
	REFLECTED POWER	xxx%	xxx%
	AMP CURRENT 1	xx.xA	xx.xA
	AMP CURRENT 2	xx.xA	xx.xA

System Component	Parameter	Normal	Faulted (Blinking)
	AMP CURRENT 3	xx.xA	xx.xA
	AMP TEMPERATURE	xxC	xxC
	CODE VERSION	x.x	N/A

Table 3-12: Menu 40 - Translator Set-up: Power Raise/Lower Screen

T R A N S M I T T E R S E T - U P				
0 1	P O W E R R A I S E / L O W E R			
	S E T T I N G 1 0 0 %			
↑	↓	(+)	E S C	(-)

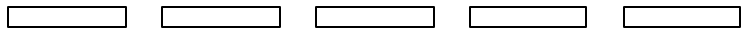

This screen of the translator is the first of several that allows access to translator set-up parameters. When + is selected, the Power will increase. When - is selected, the Power will decrease..

Table 3-13: Menu 40-1 - Translator Set-up: Model Select Screen

T R A N S M I T T E R S E T - U P				
0 2	T R A N S M I T T E R M O D E L			
	N U M B E R L U 0 1 0 0 A L			
↑	↓	(+)	E S C	(-)

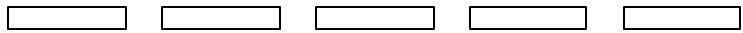

This screen is used to specify which components are expected to be part of the system. By specifying the model number, the translator control firmware knows which components should be installed and it will be able to display faults for components that are not properly responding to system commands.

Table 3-14: Menu 40-2 - Translator Set-up: Frequency Select Screen

T R A N S M I T T E R S E T - U P				
0 2	F R E Q U E N C Y S E L E C T			
	T A B L E O R C U S T O M			
↑	↓	(+)	E S C	(-)

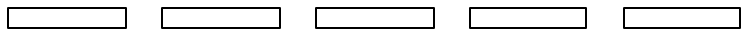

This screen of the translator is allows access to translator frequency set-up parameters. The choices of this screen are 'TABLE' or 'CUSTOM'. When table is selected, the next menu will be used to select the desired operating frequency. When custom is selected, the next menu is used to select a specific operating frequency.

Table 3-15: Menu 40-3 - Translator Set-up: Frequency Table Select Screen

T R A N S M I T T E R S E T - U P				
0 3	F R E Q U E N C Y S E L E C T			
	C H 2 0 5 0 6 - 5 1 2 M H z			
↑	↓	(+)	E S C	(-)

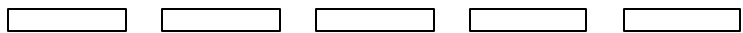

The choices of this screen are from the standard UHF / VHF tables. + and - change the desired value of the translator. Any change to frequency is immediately set to the LO / Upconverter Frequency Synthesizer PLL circuit.

Table 3-16: Menu 40-4 - Translator Set-up: IF Frequency Screen

T	R	A	N	S	M	I	T	T	E	R	S	E	T	-	U	P								
0	3										I	F	F	R	E	Q	U	E	N	C	Y			
											I	N	P	U	T	4	5	.	7	5		M	H	Z
											↑		↓			(+)		E	S	C		>

This screen is used to specify the IF Input frequency. This value plus the desired channel value is used to calculate the desired LO frequency. + is used to increase the selected value from 0 to 9. The > key is used to select from each of the different fields that make up the desired frequency. Any change to frequency is immediately set to the LO / Upconverter Frequency Synthesizer PLL circuit.

Table 3-17: Menu 40-5 - Translator Set-up: Custom Frequency Select Screen

T	R	A	N	S	M	I	T	T	E	R	S	E	T	-	U	P												
0	3										F	R	E	Q	U	E	N	C	Y	S	E	L	E	C	T			
																	0	5	0	7	.	2	5	0		M	H	Z
											↑		↓			(+)		E	S	C		(-)		

This screen is used to specify the operating frequency to an exact value. + is used to increase the selected value from 0 to 9. The > key is used to select from each of the different fields that make up the desired frequency. Any change to frequency is immediately set to the LO / Upconverter Frequency Synthesizer PLL circuit.

Table 3-18: Menu 40-6 - Translator Set-up: Serial Address Screen

T	R	A	N	S	M	I	T	T	E	R	S	E	T	-	U	P										
0	4										S	E	R	I	A	L	A	D	D	R	E	S	S	5		
											↑		↓			(+)		E	S	C		(-)

This screen allows the user to set the serial address of the translator. The default address is 5. This value and all other set-up parameters, are stored in non-volatile memory.

Table 3-19: Menu 40-7 - Translator Set-up: System Forward Power Calibration

T	R	A	N	S	M	I	T	T	E	R	S	E	T	-	U	P										
0	6										S	Y	S	T	E	M	C	A	L	I	B	R	A	T	E	
											F	O	R	W	A	R	D	P	W	R	1	0	0	%		
											↑		↓			(+)		E	S	C		(-)

This screen is used to adjust the calibration of the system's forward power. A symbol placed under the '6' character is used to show minor changes in the calibration value. When the calibration value is at full value, the character will be full black. As the value decreases, the character pixels are gradually turned off.

Table 3-20: Menu 40-8 - Translator Set-up: System Aural Power Calibration

T	R	A	N	S	M	I	T	T	E	R	S	E	T	-	U	P
0	6	S	Y	S	T	E	M	C	A	L	I	B	R	A	T	E
		A	U	R	A	L	P	W	R			1	0	0	%	
↑		↓		(+)	E	S	C		(-)			
<input type="text"/>	<input type="text"/>	<input type="text"/>	<input type="text"/>	<input type="text"/>	<input type="text"/>	<input type="text"/>	<input type="text"/>	<input type="text"/>	<input type="text"/>	<input type="text"/>	<input type="text"/>	<input type="text"/>	<input type="text"/>	<input type="text"/>	<input type="text"/>	

In analog systems, this screen is used to adjust the calibration of the system's aural forward power.

Table 3-21: Menu 40-9 - Translator Set-up: System Reflected Power Calibration

T	R	A	N	S	M	I	T	T	E	R	S	E	T	-	U	P
0	6	S	Y	S	T	E	M	C	A	L	I	B	R	A	T	E
		R	E	F	L	E	C	T	P	W	R	X	X	X	%	
↑		↓		(+)	E	S	C		(-)			
<input type="text"/>	<input type="text"/>	<input type="text"/>	<input type="text"/>	<input type="text"/>	<input type="text"/>	<input type="text"/>	<input type="text"/>	<input type="text"/>	<input type="text"/>	<input type="text"/>	<input type="text"/>	<input type="text"/>	<input type="text"/>	<input type="text"/>	<input type="text"/>	

This screen is used to adjust the calibration of the system's reflected power.

Table 3-22: Menu 40-10 - Translator Set-up: Forward Power Fault Threshold Screen

T	R	A	N	S	M	I	T	T	E	R	S	E	T	-	U	P
0	7	M	I	N	I	M	U	M	F	O	R	W	A	R	D	
		P	O	W	E	R	F	A	U	L	T		5	0	%	
↑		↓		(+)	E	S	C		(-)			
<input type="text"/>	<input type="text"/>	<input type="text"/>	<input type="text"/>	<input type="text"/>	<input type="text"/>	<input type="text"/>	<input type="text"/>	<input type="text"/>	<input type="text"/>	<input type="text"/>	<input type="text"/>	<input type="text"/>	<input type="text"/>	<input type="text"/>	<input type="text"/>	

This screen is used to set the minimum forward power fault threshold. When the translator is operating, it must operate above this value otherwise the system will shut down with fault for 5 minutes. If after five minutes the fault is not fixed, the translator will enable, measure power less than this value and again shut down for five minutes.

Table 3-23: Menu 40-11 - Translator Set-up: Reflected Power Fault Threshold

T	R	A	N	S	M	I	T	T	E	R	S	E	T	-	U	P	
0	8	M	A	X	I	M	U	M	R	E	F	L	E	C	T	E	D
		P	O	W	E	R	F	A	U	L	T		1	0	%		
↑		↓		(+)	E	S	C		(-)				
<input type="text"/>	<input type="text"/>	<input type="text"/>	<input type="text"/>	<input type="text"/>	<input type="text"/>	<input type="text"/>	<input type="text"/>	<input type="text"/>	<input type="text"/>	<input type="text"/>	<input type="text"/>	<input type="text"/>	<input type="text"/>	<input type="text"/>	<input type="text"/>		

This screen is used to set the maximum reflected power fault threshold. When the translator is operating, it must not operate above this value otherwise the system will shut down with fault for 5 minutes. If after five minutes the fault is not fixed, the translator will enable, measure power above this value and again shut down for five minutes.

Table 3-24: Menu 40-12 - Translator Set-up: Remote Commands Control

T	R	A	N	S	M	I	T	T	E	R	S	E	T	-	U	P	
0	9	R	E	M	O	T	E	C	O	N	T	R	O	L			
		C	O	M	M	A	N	D	S	A	C	C	E	P	T	E	D
		↑				↓		(+)	E	S	C		(-)
<input type="checkbox"/>	<input type="checkbox"/>	<input type="checkbox"/>	<input type="checkbox"/>	<input type="checkbox"/>	<input type="checkbox"/>	<input type="checkbox"/>	<input type="checkbox"/>	<input type="checkbox"/>	<input type="checkbox"/>	<input type="checkbox"/>	<input type="checkbox"/>	<input type="checkbox"/>	<input type="checkbox"/>	<input type="checkbox"/>	<input type="checkbox"/>	<input type="checkbox"/>	<input type="checkbox"/>

This screen is used to allow or deny the use of remote control commands. When disabled, remote commands are not used. Remote commands are commands received either through the rear terminal blocks or through serial messages.

This completes the description of the screens for the Innovator LX Series exciter/amplifier chassis assembly.

If the translator is already connected to the antenna, check that the output is 100%. If necessary, adjust the amplifier power detection circuitry or LO / Upconverter AGC settings. The power raise / lower settings are only to be used for temporary reductions in power. The

power set-back values do not directly correspond to the power of the translator. Setting for 50% output sets a linear circuit voltage which is controlling a non-linear power circuit.

If a problem occurred during the setup and operation procedures, refer to Chapter 5, Detailed Alignment Procedures, of this manual for more information.

Chapter 4 Circuit Descriptions

4.1 (A1) UHF/VHF Receiver Tray (1265-1100)

The UHF/VHF Receiver Tray w/(Optional) Frequency Correction selects the desired UHF or VHF On Channel Input Signal and converts it to a Combined IF Signal of 45.75 MHz Visual + 41.25 MHz Aural. The Tray also has provisions for a Frequency Correction Option that consists of a VCXO Channel Oscillator Assembly with a PLL Circuit which maintains an exact IF Output Frequency, over the capture range of the PLL circuit, even if the Input UHF or VHF Frequency may vary.

RF Signal Path

4.1.1 (A7) 50 Filter, DC Multiplexed, UHF (1035-1204), VHF L.B. (1035-1902) or VHF H.B. (2065-1024) or 75 , UHF (1035-1207), VHF L.B. (1035-1903) or VHF H.B. (2065-1023)

The RF Input to the Tray, (-61 dBm to -16 dBm in Level), is fed through J1 for 50Ω to (A7) the input 50Ω Filter, DC Multiplexed (1035-1204 UHF, 1035-1902 VHF LB or 2065-1024 VHF HB) or through J5 for 75Ω to (A7) the 75Ω input Filter, DC Multiplexed (1035-1207 UHF, 1035-1903 VHF LB or 2065-1023 VHF HB), which is of a double tuned design that is adjusted to the desired Input UHF or VHF Channel Frequency. Note: If the input signal is greater than -25dBm, an attenuator should be used to limit the level to -25dBm. +12 VDC, for use by an (Optional) external Preamplifier Assembly, connects to the filter through F1 a 1 Amp Fuse. This +12 VDC is DC Multiplexed onto the input signal cable from the Preamplifier. DS1 a Red LED located on TB1 in the Tray will be lit if the +12 VDC is present on the input cable. If a Preamplifier is not used, F1 should be removed and DS1 should not be lit.

4.1.2 (A8) Dual Stage Amplifier Assembly (1227-1503)

The signal is next amplified +12 dB to approximately the -49 to -4 dBm level by a low noise amplifier located on (A8-A1) the Dual Stage Amplifier Board (1227-1501) that is contained in (A8) the Dual Stage Amplifier Assembly (1227-1503). The board has approximately +13 dB or +26 dB of gain, depending on whether Jumper W1 on J5 is in place. The amplified output connects out of the board at J2.

4.1.3 (A9) Channel Filter, UHF (1007-1101), VHF L.B. (1034-1202) or VHF H.B. (2065-1000)

The signal is then filtered in (A9) a Channel Filter (1007-1101 UHF, 1034-1202 VHF LB or 2065-1000 VHF HB) and then applied back to (A8-A1) the Dual Stage Board at J3.

More amplification of the signal takes place on the Dual Stage Board, if needed. Jumper W1 on J7 should be removed if the Receiver Input level is greater than -40dBm.

4.1.4 (A10) Downconverter Amplifier Assembly, 45.75 MHz. (1227-1505)

The output is connected to (A10) the Downconverter Amplifier Assembly (1227-1505) that contains (A10-A1) the Downconverter Amplifier Board (1227-1502). The RF, at the -47 dBm to -2 dBm Level, connects to the "R" Input Jack of the Mixer Z1 located on the Downconverter Amplifier Board.

Local Oscillator Signal Path

The Local Oscillator Signal is derived from a cut to channel crystal mounted in an oven that is factory set at 45° C. The Oscillator operates at 1/8 for UHF, 1/4 for

VHF High Band or 1/2 for VHF Low Band of the desired local oscillator frequency.

4.1.5 (A4) Channel Oscillator Assembly (1145-1202)

The crystal is mounted on (A4-A1) the Channel Oscillator Board, Dual Oven (1145-1201), that is part of the Channel Oscillator Assembly (1145-1202). The oscillator circuitry is a modified Colpitts design operating in a separate oven set at 50° C. for improved stability. If the Frequency Correction Option is purchased, the VCXO Channel Oscillator Assembly (1145-1206), which contains the VCXO Channel Oscillator Board (1145-1204), is used in place of the standard Channel Oscillator Assembly, and an AFC voltage from the PLL circuit maintains the frequency of the VCXO.

4.1.6 (A5-A1) x8 Multiplier Board (1227-1002), x2 Multiplier Board (1227-1524) or x4 Multiplier Board (1227-1525)

The output of the Channel Oscillator is connected to the (A5-A1) the x8 Multiplier Board (1227-1002) for UHF, the x4 Multiplier Board (1227-1525) for VHF HB or the x2 Multiplier Board (1227-1524) for VHF LB, which is located in (A5) the Multiplier Enclosure (1265-1125). The proper multiplier board takes the output of the Channel Oscillator (+3 dBm) and multiplies it eight, four or two times by a series of three, two or one x2 Broadband Doublers ($2 \times 2 \times 2 = x8$), which produces the L.O. signal on the desired frequency needed for the upconversion process. The signal is then amplified to the +16 dBm level. A sample of the multiplied L.O. Signal is fed to a detector circuit which lights the Green LED DS1 that indicates that the L.O. is present at the Output Jack J2 of the Multiplier Board. This Green LED is seen through a hole the lid of the Multiplier Assembly and is an indication, when lit, that there is a signal present at the output of the Multiplier Board.

4.1.7 (A6) L.O. Filter, UHF (1007-1101), VHF L.B. (1034-1211) or VHF H.B. (2065-1000)

The L.O. signal is filtered in (A6) a L.O. Filter 1007-1101 UHF, 2065-1000 VHF HB or 1034-1211 VHF LB) and then sent (+15 dBm) to J2 on (A10-A1) the Downconverter Amplifier Board.

The L.O. Input to the Downconverter Amplifier Board is connected thru a 3 dB matching pad to the "L" Input of the Mixer (Z1) at a +12 dBm level.

Combined IF Signal Path

The L.O. and the RF signals are mixed in the Mixer Stage of the Downconverter Amplifier Board to produce the desired IF difference frequency at -55 dBm to -10 dBm in level, depending on the RF Input Level.

4.1.8 (A11-A1) IF Filter/ALC Board (1227-1504)

The Combined IF Signal is routed to (A11-A1) the IF Filter/ALC Board (1227-1504), which is mounted in (A11) the IF Filter/ALC Enclosure (1265-1105). The IF Filter/ALC Board contains a Pin Diode Attenuator circuit which is part of the Automatic Level Control (ALC) that controls the level of the IF Signal to the two stage amplifier ICs U1 and U2.

4.1.9 (A11-A2) (Optional) SAW Filter/Amplifier Board (1035-1211)

The (Optional) (A11-A2) SAW Filter/Amplifier Board (1035-1211) is also contained in the IF Filter/ALC Enclosure. The SAW Filter/Amplifier Board connects to J5 and J6 of the IF Filter/ALC Board if more attenuation of the Out Of Band products is needed. If the SAW Filter/Amplifier Board is not needed, a jumper connects the Combined IF from J5 to J6 on the IF Filter/ALC Board.

The Combined IF is then bandpass filtered to the needed 6 MHz IF bandwidth around

the 41.25 MHz + 45.75 MHz Combined IF signal and amplified by U3 to the -41 dBm to +4 dBm Level before it is split. One output is detected by U4 for use as the ALC reference level to the Pin Diode Attenuator Circuit. The ALC comparator drives the Pin Diode Attenuator Circuit to maintain the desired output level, typically +2 dBm. The other split output connects to J2 the Combined IF Output of the board that is cabled to the IF Output Jack of the Tray at J4 (+2 dBm).

Frequency Correction Option

If the Frequency Correction Option (1227-1528) is purchased, (A13) the IF Filter/Limiter Board (1109-1001), (A14) the IF PLL Board (1109-1002), the (A15) IF Carrier Oven Oscillator Board (1100-1206), (A4) the VCXO Channel Oscillator Assembly (1145-1206) and (A16) an IF Amplifier Board, High Gain (1197-1126) are part of the System.

4.1.10 (A13) (Optional) IF Amplifier Board (1197-1126)

A Sample of the amplified and ALC controlled signal from the IF Filter/ALC Board is directed to the IF Amplifier Board, High Gain (1197-1126) where it is amplified and connected to J2 on (A13) the IF Filter/Limiter Board (1109-1001).

4.1.11 (A13) (Optional) IF Filter/Limiter Board (1109-1001)

The IF is filtered by a SAW Filter, which passes Visual Carrier and Aural Carrier only, and amplified before it is split. The Aural IF Output is not used in this Tray. The other output of the splitter is amplified and applied to a Notch Filter. The Notch Filter is tuned to the Aural Frequency by C17 and R10 which reduces or eliminates the Aural IF from the Visual IF signal. The Visual IF Only signal then connects to a video detector circuit which in conjunction with U5 strips the video from the Visual IF signal. The IF CW Signal is amplified and buffered before it is connected to the output of the

board at J6. The IF CW connects to J2 of (A14) the IF PLL Board (1109-1002).

4.1.12 (A14) (Optional) IF PLL Board (1109-1002)

The IF CW Signal (+3 dBm) on the IF PLL Board is wired to U1 a Divider IC which, in conjunction with U2, sets up one of the reference signals to the comparator circuit. The other reference signal is derived from the 50 kHz reference Input at J4 which is a divided down 50 kHz sample of the 38.9 MHz signal generated on (A15) the IF Carrier Oven Oscillator Board (1100-1206).

4.1.13 (A15) (Optional) IF Carrier Oven Oscillator Board (1100-1206)

The 38.9 MHz IF Carrier Oven Oscillator Board is used instead of the 45.75 MHz IF Carrier Oven Oscillator Board to minimize the interference between the generated 45.75 MHz IF and the signal generated on the (A15) IF Carrier Oscillator Board. The 38.9 MHz signal itself is not used, just the divided down 50 kHz reference of the 38.9 MHz Signal is used. The two reference signals applied to the IF PLL Board are compared by U2 and a difference voltage (AFC) is produced. The difference voltage (AFC), approximately -3 VDC, is fed from J3 of the board to FL2 of (A4) the VCXO Assembly. If the frequency of the VHF or UHF Input to the Tray should drift, the ALC voltage will change to increase or decrease the output frequency of the VCXO Assembly which increases or decreases the L.O. Frequency that maintains the IF Frequency at the standard 45.75 + 41.25 MHz Frequency. If the frequency of the Input Signal should drift out of the capture range of the PLL Circuit, DS1 the Red LED Unlock Indicator, located on the IF PLL Board, lights.

Voltages for Operation of the Tray

The AC input to the Tray is 117 VAC or 230 VAC and is directed thru Jack J2, of the (A1) Power Entry Module (1265-1104), to the step down Toroid (A2). The Power Entry Module contains an On/Off Switch, a

4 Amp Slo-Blo Fuse and three MOVs which protect the Tray from transients or surges which may occur on the AC Input Lines. When the On/Off Switch is switched On, AC is applied to the (A2) Toroid. The Toroid steps down the voltage into two 16 VAC outputs which are fed to (A3) the +12V(3A)/-12V Power Supply Board (1092-1206).

4.1.14 (A3) +12V(3A)/-12V Power Supply Board (1092-1206)

The 16 VAC Inputs are connected to the two full wave bridge networks one for +12 VDC and one for -12 VDC. The output of the +12 VDC rectifier is fed to three 7812 IC regulators (U1, U2 and U3) and the output of the -12 VDC rectifier is fed to one 7912 IC regulator (U4). The ± 12 V Power Supply Board provides the voltage regulated and current limited +12 VDC and -12 VDC to the rest of the boards in the Tray.

+12VDC for External Preamplifier

+12 VDC is also applied through a 1 Amp Fuse F1 to (A7) the input DC Multiplexed UHF or VHF Filter. The +12 VDC is multiplexed in the Filter onto the input coaxial cable that connects from the (Optional) Remote Preamplifier Unit to the Receiver Tray. This supplies the Preamplifier with the +12 VDC needed for operation. The Red LED DS1 mounted on the Terminal Block TB1 will be lit if the +12 VDC is applied to the coaxial cable. Note: If the Red LED, DS1, is lit, the +12 VDC may damage Test Equipment that is connected to the input of the Receiver Tray. If a Preamplifier Assembly is not part of your System, F1 should be removed, therefore DS1 should not be lit and the +12 VDC is not multiplexed onto the input coaxial cable. A spare Fuse for F1 is supplied and stored near the fuse holder for F1.

UHF Exciter

4.2 (A3) IF Processor Module Assembly (1301938)

The IF from the Receiver Tray enters the module and the signal is pre-corrected as needed for amplitude linearity correction, Incidental Carrier Phase Modulation (ICPM) correction and frequency response correction.

The IF Module contains the following board.

4.2.1 IF Processor Board (1301977)

The automatic level control (ALC) portion of the board provides the ALC and amplitude linearity correction of the IF signal. The ALC adjusts the level of the IF signal that controls the output power of the transmitter.

The IF from the Receiver Tray enters the board at J1B pin 32B. If the (optional) receiver tray is present, the IF input (0 dBm) from the Receiver Tray connects to the modulated IF input jack J1C Pin 21C. The modulated IF input connects to relay K3 and the receiver IF input connects to relay K4. The two relays are controlled by the Modulator Select command that is connected to J1C Pin 14C on the board. Modulator select enable/disable jumper W11 on J29 controls whether the Modulator Select command at J1C Pin 14C controls the operation of the relays. With jumper W11 on J29 between pins 1 and 2, the Modulator Select command at J1C Pin 14C controls the operation of the relays; with jumper W11 on J29, pins 2 and 3, the modulator is selected all of the time.

4.2.1.1 Modulator Selected

With the modulator selected, J1C-14C low, this shuts off Q12 and causes Pin 8 on the relays to go high that causes relays K3 and K4 to de-energize. When K4 is de-energized, it connects the receiver IF input at J1C-21C, if present, to a 50 Ω load. When K3 is de-energized, it connects the modulator IF input at J1B-32B to the rest of the board; Modulator Enable LED DS5 will be illuminated.

4.2.1.2 External Modulated IF Selected

With the External Modulated IF selected, J1C-14C high, this turns on Q12 and makes pin 8 on the relays low that causes the relays K3 and K4 to energize. When K4 is energized, it connects the receiver IF input at J at J1C-21C, if present, to the rest of the board. When K3 is energized, it connects to the modulator IF input at J1B-32B to a 50Ω load. The Modulator Enable LED DS5 will not be illuminated.

4.2.1.3 Main IF Signal Path (Part 1 of 3)

The selected IF input (-6 dBm average) signal is split, with one half of the signal entering a bandpass filter that consists of L3, L4, C4, L5, and L6. This bandpass filter can be tuned with C4 and is substantially broader than the IF signal bandwidth. It is used to slightly steer the frequency response of the IF to make up for any small discrepancies in the frequency response in the stages that precede this point. The filter also serves the additional function of rejecting unwanted frequencies that may occur if the tray cover is off and the tray is in a high RF environment. (If this is the case, the transmitter will have to be serviced with the tray cover off in spite of the presence of other RF signals). The filtered IF signal is fed through a pi-type matching pad consisting of R2, R3, and R4 to the pin-diode attenuator circuit consisting of CR1, CR2, and CR3.

4.2.1.4 Input Level Detector Circuit

The other part of the split IF input is connected through L2 and C44 to U7. U7 is an IC amplifier that is the input to the input level detector circuit. The amplified IF is fed to T4, which is a step-up transformer that feeds diode detector CR14. The positive-going detected signal is then low-pass filtered by C49, L18, and C50. This allows only the positive digital peaks to be applied through emitter follower Q1. The signal is then connected to detector CR15 to produce a peak

digital voltage that is applied to op-amp U9A. There is a test point at TP3 that provides a voltage-reference check of the input level. The detector serves the dual function of providing a reference that determines the input IF signal level to the board and also serves as an input threshold detector.

The input threshold detector prevents the automatic level control from reducing the attenuation of the pin-diode attenuator to minimum, the maximum signal output, if the IF input to the board is removed. The ALC, input loss cutback, and the threshold detector circuits will only operate when jumper W2 on jack J5 is in the Enabled position, between pins 2 and 3. Without the threshold detector, and with the pin-diode attenuator at minimum, the signal will overdrive the stages following this board when the input is restored.

As part of the threshold detector operation, the minimum IF input level at TP3 is fed through detector CR15 to op-amp IC U9A, pin 2. The reference voltage for the op-amp is determined by the voltage divider that consists of R50 and R51, off the +12 VDC line. When the detected input signal level at U9A, pin 2, falls below this reference threshold, approximately 10 dB below the normal input level, the output of U9A at pin 1 goes high, toward the +12 VDC rail. This high is connected to the base of Q2 that is forward biased and creates a current path. This path runs from the -12 VDC line and through red LED DS1, the input level fault indicator, which lights, resistor R54, and transistor Q2 to +12 VDC. The high from U9A also connects through diode CR16 and R52, to U24D pin 12, whose output at pin 14 goes high. The high connects through the front panel accessible ALC Gain pot R284 and the full power set pot R252 to U24C Pin 9. This high causes U24C pin 8 to go low. A power raise/lower input from the Control/Monitoring Module connects to J42C pin 24C and is wired to Q14. This input will increase or decrease the value of the low applied to U24B and therefore

increase or decrease the power output of the transmitter.

The low connects to U24B pin 5 whose output goes low. The low is wired to U24A pin 2 whose output goes high. The high is applied to U10A, pin 2, whose output goes low. The low connects through the switch SW1, if it is in the auto gain position, to the pin-diode attenuator circuit, CR1, CR2 & CR3. The low reverse biases them and cuts back the IF level, therefore the output level, to 0. When the input signal level increases above the threshold level, the output power will increase, as the input level increases, until normal output power is reached.

The digital input level at TP3 is also fed to a pulse detector circuit, consisting of IC U8, CR17, Q3, and associated components, and then to a comparator circuit made up of U9C and U9D. The reference voltage for the comparators is determined by a voltage divider consisting of R243, R65, R66, and R130, off the -12 VDC line. When the input signal level to the detector at TP3 falls below this reference threshold, which acts as a loss-of-digital peak detector circuit, the output of U9C and U9D goes towards the -12 VDC rail and is split, with one part biasing on transistor Q5. A current path is then established from the +12 VDC line through Q5, the resistors R69 and R137, and the red LED DS3, input loss indicator, which is illuminated. When Q5 is on, it applies a high to the gate of Q6. This causes it to conduct and apply a modulation loss pull-down output to J42C, pin 7C, which is applied to the front panel display on the Control/Monitor module.

The other low output of U9C and U9D is connected through CR18, CR19 & CR20 to jack J5. Jumper W2 on J5, in the Cutback Enable position, which is between pins 2 and 3, connects the low to the base of Q4 that is now forward-biased. **NOTE:** If jumper W2 is in the Disable position, between pins 1 and 2,

the auto cutback will not operate. With Q4 biased on, a negative level determined by the setting of cutback level pot R71 is applied to U24D, pin 12. The level is set at the factory to cut back the output to approximately 25%. The output of U24D at pin 14 goes low and is applied through the power adjust pot to U24C, pin 9, whose output goes low.

The low connects to U24B, pin 5, whose output goes low. The low then connects to U24A, pin 2, whose output goes high. The high is applied to U10A, pin 2, whose output goes low. The low connects through the switch SW1, if it is in the auto gain position, to the to the pin-diode attenuator circuit, CR1, CR2 & CR3. The low reverse biases them and cuts back the level of the output to approximately 25%.

4.2.1.5 Pin-Diode Attenuator Circuit

The input IF signal is fed to a pin-diode attenuator circuit that consists of CR1, CR2 & CR3. Each of the pin diodes contains a wide intrinsic region; this makes the diodes function as voltage-variable resistors at this intermediate frequency. The value of the resistance is controlled by the DC bias supplied to the diode. The pin diodes are configured in a pi-type attenuator configuration where CR1 is the first shunt element, CR3 is the series element, and CR2 is the second shunt element. The control voltage, which can be measured at TP1, originates either from the ALC circuit when the switch SW1 is in the ALC Auto position, between pins 2 and 3, or from pot R87 when SW1 is in the Manual Gain position, between pins 1 and 2.

In the pin diode attenuator circuit, changing the amount of current through the diodes by forward biasing them changes the IF output level of the board. There are two extremes of attenuation ranges for the pin-diode attenuators. In the minimum attenuation case, the voltage, measured at TP1, approaches the +12 VDC line. There is a current path created through R6, through series diode CR3, and finally through R9 to ground. This

path forward biases CR3 and causes it to act as a relatively low-value resistor. In addition, the larger current flow increases the voltage drop across R9 that tends to turn off diodes CR1 and CR2 and causes them to act as high-value resistors. In this case, the shunt elements act as a high resistance and the series element acts as a low resistance to represent the minimum loss condition of the attenuator (maximum signal output). The other extreme case occurs as the voltage at TP1 is reduced and goes towards ground or even slightly negative. This tends to turn off (reverse bias) diode CR3, the series element, causing it to act as a high-value resistor. An existing fixed current path from the +12 VDC line, and through R5, CR1, CR2, and R9, biases series element CR3 off and shunt elements, diodes CR1 and CR2, on, causing them to act as relatively low-value resistors. This represents the maximum attenuation case of the pin attenuator (minimum signal output). By controlling the value of the voltage applied to the pin diodes, the IF signal level is maintained at the set level.

4.2.1.6 Main IF Signal Path (Part 2 of 3)

When the IF signal passes out of the pin-diode attenuator through C11, it is applied to modular amplifier U1. This device contains the biasing and impedance-matching circuits that makes it operate as a wide-band IF amplifier. The output of U1 connects to J40 that is jumpered to J41. The J40 jack is available, as a sample of the pre-correction IF for troubleshooting purposes and system setup. The IF signal is connector to a splitter Z1 that has an in phase output and a 90° Quadrature output, which are then connected to the linearity corrector portion of the board.

4.2.1.7 Amplitude and Phase Pre-Correction Circuits

The linearity corrector circuits use three stages of correction, two adjust for any amplitude non-linearities and one for

phase non-linearities of the output signal. Two of the stages are in the in phase amplitude pre-correction path and one stage is in the quadrature phase pre-correction path. Each stage has a variable threshold control adjustment, R211 and R216, in the in phase path, and R231, in the quadrature path, that determines the point at which the gain is changed for that stage.

Two reference voltages are needed for the operation of the corrector circuits. The Zener diode VR3, through R261, provides the +6.8 VDC reference. The VREF is produced using the path through R265 and the diodes CR30 and CR31. They provide a .9 VDC reference, which temperature compensates for the two diodes in each corrector stage.

The first corrector stage in the in phase path operates as follows. The in phase IF signal is applied to transformer T6, which doubles the voltage swing by means of a 1:4 impedance transformation. Resistors R222 and R225 form an L-pad that lowers the level of the signal. The input signal level when it reaches a certain level causes the diodes CR24 and CR25 to turn on, generating current flow that puts them in parallel with the L-pad. When the diodes are put in parallel with the resistors, the attenuation through the L-pad is lowered, causing signal stretch.

The signal is next applied to amplifier U17 to compensate for the loss through the L-pad. The breakpoint, or cut-in point, for the first corrector is set by controlling where CR24 and CR25 turn on. This is accomplished by adjusting the threshold cut-in resistor R211. R211 forms a voltage-divider network from +6.8 VDC to ground. The voltage at the wiper arm of R211 is buffered by the unity-gain amplifier U16B. This reference voltage is then applied to R215, R216, and C134 through L44 to the CR24 diode. C134 keeps the reference from sagging during the vertical interval. The .9 VDC reference voltage is applied to the unity-gain amplifier U16D. The reference voltage is

then connected to diode CR25 through choke L45. The two chokes L44 and L45 form a high impedance for RF that serves to isolate the op-amp ICs from the IF.

After the signal is amplified by U17, it is applied to the second corrector stage in the in phase path through T7. These two correctors and the third corrector stage in the quadrature path operate in the same fashion as the first. All three corrector stages are independent and do not interact with each other.

The correctors can be disabled by moving jumper W12 on J30 to the Disable position, between pins 1 and 2, this moves all of the breakpoints past the greatest peaks of digital so that they will have no affect.

The pre-distorted IF signal in the in phase path, connects to an op amp U18 whose output level is controlled by R238. R238 provides a means of balancing the level of the amplitude pre-distorted IF signal that then connects to the combiner Z2.

The pre-distorted IF signal in the quadrature path connects to op amp U20 and then step up transformer T9, next op amp U21 and step up transformer T10 and finally op amp U22 whose output level is controlled by R258. R258 provides a means of balancing the level of the Phase pre-distorted IF signal that then connects to the combiner Z2.

The amplitude and phase pre-distorted IF signals are combined by Z2 and connected to J37 that is jumpered to J36 on the board. J37 can be used for testing or monitoring purposes of the IF signal after amplitude and phase pre-distortion. The pre-distorted IF signal connects through a resistor buffer network that prevents loading of the combiner before it is wired to the frequency response circuitry.

4.2.1.8 Main IF Signal Path (Part 3 of 3)

The IF signal, at the input to the frequency-response corrector circuit, is split using L24, L25 and R89. One path is through L24, which is the main IF path through the board. The main IF is fed through a resistor network that controls the level of the IF by adjusting the resistance of R99, the output level adjust. The IF signal is then applied to a three-stage, frequency-response corrector circuit that is adjusted as needed.

The frequency-response corrector circuit operates as follows. Variable resistors R103, R106 and R274 are used to adjust the depth and gain of the notches and variable caps C71, C72 and C171 are used to adjust the frequency position of the notches. These are adjusted as needed to compensate for frequency response problems.

The frequency-response corrected IF is connected to J38 that is jumpered to J39 on the board. J38 can be used for testing or monitoring purposes of the IF signal after frequency response pre-correction. The IF is next amplified by U13 and U14. After amplification, the IF is split with one path connected to J42C pin 1C the IF output to the LO/Upconverter Module. The other path is fed through a divider network to J35 a SMA IF Sample Jack, located on the front panel, that provides a sample of the corrected IF for test purposes.

4.2.1.9 ALC Circuit

The other path of the corrected IF signal at the input to the frequency response corrector circuit is used in the ALC circuit. The IF flows through L25, of the L24 L25 splitter, and connects to the op-amp U12. The IF signal is applied through a resistor divider network to transformer T5. T5 doubles the voltage swing by means of a 1:4 impedance transformation before it is connected to the ALC detector circuit, consisting of C70, CR23 and R91. The detected ALC level output is amplified by U10B and wired to U10A, pin 2, where it is summed with the power control setting,

which is the output power setting that is maintained by the ALC. The output of U10A connects through SW1, if it is in the auto gain position, to the pin-diode attenuator circuit, CR1, CR2 & CR3. The high forward biases them more or less, that increases or decreases the IF level, therefore the output level, opposite the input level. When the input signal level increases, the forward bias on the pin attenuator decreases, therefore the output power will decrease, which keeps the output power the same as set by the customer.

An external power raise/lower switch can be used by connecting it to TB30, at TB30-8 power raise and TB30-9 power lower, on the rear of the exciter/amplifier chassis. The ALC voltage is set for .8 VDC at TP4 with a 0-dBm output at J42C pin 1C of the module. A sample of the ALC at J42C pin 11C, is wired to the Control Monitoring/Power Supply module where it is used on the front panel display and in the AGC circuits.

The ALC voltage, and the DC level corresponding to the IF level after signal correction, are fed to U10A, pin 2, whose output at pin 1 connects to the ALC pin-diode attenuator circuit. If there is a loss of gain somewhere in an IF circuit, the output power of the transmitter will drop. The ALC circuit senses this drop at U10A and automatically decreases the loss through the pin-diode attenuator circuit therefore increasing its gain maintaining the same output power level.

The ALC action starts with the ALC detector level monitored at TP4. The detector output at TP4 is nominally +.8 VDC and is applied through resistor R77 to a summing point at op-amp U10A, pin 2. The current available from the ALC detector is offset, or complemented, by current taken away from the summing junction. In normal operation, U10A, pin 2, is at 0 VDC when the loop is satisfied. If the recovered or peak-detected IF signal level at IF input to this board should drop, which normally means that

the output power will decrease, the null condition would no longer occur at U10A, pin 2. When the level drops, the output of U10A, pin 1, will go more positive. If SW1 is in the Automatic position, it will cause the ALC pin-diode attenuators CR1, CR2, and CR3 to have less attenuation and increase the IF level; this will compensate for the decrease in the level. If the ALC cannot increase the input level enough to satisfy the ALC loop, due to there not being enough range, an ALC fault will occur. The fault is generated because U10D, pin 12, increases above the trip point set by R84 and R83 until it conducts. This makes U10D, pin 14, high and causes the red ALC Fault LED DS2 to light.

4.2.1.10 Fault Command

The board also has circuitry for an external mute fault input at J42 pin 10C. This is a Mute command that protects the circuits of high-gain output amplifier devices against VSWR faults. This action needs to occur faster than just pulling the ALC reference down. Two different mechanisms are employed: one is a very fast-acting circuit to increase the attenuation of the pin-diode attenuator, CR1, CR2, and CR3, and the second is the reference voltage being pulled away from the ALC amplifier device. An external Mute is a pull-down applied to J42 pin 10C, that completes a current path from the +12 VDC line through R78 and R139, the LED DS4 (Mute indicator), and the LED section of opto-isolator U11. These actions turn on the transistor section of U11 that applies -12 VDC through CR21 to U10A pin 3, and pulls down the reference voltage. This is a fairly slow action controlled by the low-pass filter function of R81 and C61. When the transistor section of U11 is on, -12 VDC is also connected through CR22 directly to the pin-diode attenuator circuit. This establishes a very fast muting action, by reverse biasing CR3. This action occurs in the event of an external VSWR fault.

4.2.1.11 ± 12 VDC Needed to Operate the Board

The ± 12 VDC connects to the board at J42C. The +12 VDC connects to J42C pin 16C and is filtered by L30, L41, and C80 before it is applied to the rest of the board. The -12 VDC connects to J42C pin 18C and is filtered by L31 and C81 before it is applied to the rest of the board.

The +12 VDC also connects through R261 to the zener diode VR3 that connects to ground, which generates the +6.8 VDC output to the rest of the board.

The +12 VDC also connects through R265 to the diodes CR30 and CR31 provide a .9 VDC reference output voltage VREF that temperature compensates for the two diodes in each corrector stage.

4.3 (A5) LO/Upconverter Module (1301930)

This module contains the LO/Upconverter board, the UHF Generator Board, LED Display Board and channel filters. This module takes an external IF and converts it to the final RF output frequency using an internally generated local oscillator.

The local oscillator consists of a VCXO that is phase locked to an external 10 MHz reference. The 10 MHz reference and the VCO are both divided down to 5 kHz and compared by the phase lock loop circuit. Any error from this comparison is generated in the form of an error current that is converted to a bias voltage that connects to the VCO. This voltage adjusts the output frequency of the VCO until it is on the desired frequency.

The Phase lock loop is programmed by loading in data generated by the control module. This data sets the dividers so that the 10MHz and the VCXO frequency are divided to 5kHz. These divide numbers are loaded into U6 using the clock, data and LE lines. This data is sent whenever the module is first

plugged into the backplane board or when power is applied to the transmitter. This is necessary because the divide numbers are lost when power is removed from the module.

There is an alarm generated if the phase locked loop is unlocked. This alarm is displayed locally and is also sent to the control module in the transmitter to be displayed as a fault. The bias voltage to the VCO is also available to be monitored at TP1 and also can be viewed on the front panel display of the Transmitter. Typical values for this voltage are 0.1 to 0.5V. The 10 MHz reference is normally an external reference. There is also a high stability internal reference option that is available if there is a desire to operate the transmitter without an external reference. Jumper W1 determines whether an external or internal high stability reference is to be used.

The IF signal is applied at a level of -15 dBm average and is converted to the final RF channel frequency. The RF signal is applied to a filter that selects the right conversion product. Next, the signal is amplified to -7 dBm by A3 and exits the front of the module at J2. There are also a front panel samples of the RF output at J3 and the LO at J1. The RF sample level is approximately -20 dB below the RF output. The LO sample level is -7 dBm.

4.3.1 (A4) UHF Generator Board (1585-1265)

The UHF generator board is mounted in the UHF Generator Enclosure for EMI and RFI protection. The board contains a VCXO circuit and additional circuitry to multiply the VCXO frequency by eight.

The VCXO circuit uses the crystal Y1, mounted in a crystal oven for stability, to produce an output of ≈ 67 MHz to 132 MHz, depending on the desired channel frequency. Course adjustment to the frequency of the crystal is made by C11, while fine adjustments are accomplished by

the AFC voltage at J2 from (A1) the LO/Upconverter board (1302132). The VCXO output level is adjusted by C6, L2, L4 and C18. The output is split and provides an input to the x8 multiplier circuitry as well as a VHF Output sample at J1.

The x8 circuitry consists of three identical x2 broadband frequency doublers. The input signal at the fundamental frequency is fed through a 6-dB pad consisting of R21, R24, and R25 through C29 to amplifier U3. The output of the amplifier stage is directed through a bandpass filter consisting of L8 and C32, which is tuned to the fundamental frequency (67 MHz to 132 MHz). The voltage measured at TP1 is typically +.6 VDC. The first doubler stage consists of Z1 with bandpass filter L9 and C34 tuned to the second harmonic (134 MHz to 264 MHz). The harmonic is amplified by U4 and again bandpass filtered at the second harmonic by C38 and L11 (134 MHz to 264 MHz). The voltage measured at TP2 is typically +1.2 VDC. The next doubler stage consists of Z2 with bandpass filter C40 and L12 tuned to the fourth harmonic of the fundamental frequency (268 MHz to 528 MHz). The fourth harmonic is then amplified by U5 and fed through another bandpass filter tuned to the fourth harmonic consisting of L14 and C44 (268 MHz to 528 MHz). The voltage measured at TP3 is typically +2.0 VDC. The final doubler stage consists of Z3 with bandpass filter C46 and L15 tuned to the eighth harmonic of the fundamental frequency (536 MHz to 1056 MHz). The signal is amplified by U6 and U7 to a typical value of from +2 to +4 VDC as measured at TP4. The amplified eighth harmonic is then fed to the SMA RF output jack of the board at J3. Typical output level of the signal is +16 dBm nominal. This output connects through A5 a channel filter to the LO/Upconverter Board.

The DC voltages needed to operate the UHF generator board are supplied by the LO/Upconverter Board. The +12 VDC for

the board enters through jack J4-3 and is filtered by L22 and C54-C58 before being distributed to the circuits on the board.

The +9 VDC for the board enters through jack J4-1 and is distributed to the rest of the board.

4.3.2 (A2 and A5) UHF Filters (1007-1101)

Both UHF filters are tunable two-section cavity filters that are typically tuned for a bandwidth of 6 MHz and have a loss of -1 dB through the filter.

4.3.3 (A1) LO/Upconverter Board (1302132)

The upconverter portion of the board

The LO/Upconverter board provides upconversion processing by mixing the IF and LO signals in mixer Z1 to produce the desired RF frequency output. The RF output is connected through J4 to A5, an external channel filter, and applied back to the board at J6. The RF is amplified and connected to the RF output jack of the board at J43-25B.

The IF signal (-6 dBm average) enters the board at J43-2B and is applied through a matching pad and filter circuit to the mixer. The pad consists of R6, R2 and R7, which presents a relatively good source impedance. The IF is then connected through a voltage divider network consisting of R3, R4, R8 and R14. R14 is variable and adjusted to set the 0 dBm IF input level to the mixer. The IF is next filtered by L3, C84 and C83 and connected to pin 5, the I input of the mixer Z1.

The local oscillator signal (+13 dBm) from UHF Generator Board, through (A5) a UHF channel filter, connects to the board at jack J1, an SMA connector. THE LO is connected directly to pin 1, the L input of the mixer Z1.

The frequency of the LO is the sum of the IF frequency above the required digital

carrier. For instance, in system M, for digital applications, the LO is the center frequency of the digital channel added to the 44-MHz IF frequency. By picking the local oscillator to be 44 MHz above the digital carrier, a conversion in frequency occurs by selecting the difference product. The difference product, the local oscillator minus the IF, will be at the desired digital carrier frequency output. There will also be other signals present at the RF output connector J3 at a lower level. These are the sum conversion product: the LO and the IF frequencies. Usually, the output product that is selected by the tuning of the external filter is the difference product: the LO minus the 44-MHz IF.

If a bad reactive load is connected to the mixer, the LO signal that is fed through it can be increased because the mixer no longer serves as a double-balanced mixer. The mixer has the inherent property of suppressing signals that may leak from one input port to any of the other ports. This property is enhanced by having inputs and outputs of the mixer at 50 Ω impedance. The RF output of the mixer connects through a pad made up of R12, R15, and R17 before it is wired to the amplifier U2. The RF signal is amplified by U2, a modular amplifier, and includes within it biasing and impedance matching networks that makes U2 act as a wideband-RF amplifier device. This amplifier, in a 50 Ω system, has approximately 12 dB of gain. U2 is powered from the +12 VDC line through RF decoupling components R24, C14, and L4. Inductor L4 is a broadband-RF choke and is resonance free through the UHF band. The amplified RF connects through a pad to the SMA RF output jack J4 and is cabled to (A2) an external channel filter. The reactive channel filter that is externally connected to J4 of the board does not appear as a good 50- Ω load at all frequencies. The pad, in the output line of the board, consisting of R20, R18, and R21 buffers the bad effects of the reactive filter load and makes it appear as a 50 Ω impedance.

The RF input signal from the external filter re-enters the board at J6 (-11 to -17 dBm) and is capacitively coupled to the pin-diode attenuator circuit consisting of CR2, CR3, and CR4. The pin-diode attenuator acts as a voltage-variable attenuator in which each pin diode functions as a voltage-variable resistor that is controlled by the DC bias connected to the diodes. The pin diodes, because of a large, intrinsic region, cannot rectify signals at this RF frequency; therefore, they only act as a linear voltage-variable resistor. These diodes are part of the AGC for the transmitter.

The automatic gain control (AGC) portion of the board

The automatic gain control (AGC) provides automatic gain control for the power amplifier module(s).

The AGC circuitry attempts to maintain the ratio between an input reference proportional to the input power and the output power of either the exciter/amplifier PA output, AGC #1, Inner Loop, or the output of external power amplifiers, AGC #2, Outer Loop, farther downstream. **NOTE:** The AGC #2 Outer Loop is not used in 5W-50W digital transmitters.

An ALC reference input is applied to the board at J43-16A, amplified by U10A, and sent to the front panel board through J5-7 where it is connected to a AGC Manual Gain pot, accessed through the front panel. A switch AUTO/MAN AGC is also located on the front panel. When switched in MAN the MAN GAIN Pot adjusts the output power level. The Gain Control voltage is reapplied to the board at J5-6. The gain control voltage is summed to the added together inner and outer loop AGC reference voltage at U10D.

The AGC output reference from the exciter/amplifier PA module, AGC #1 INNER LOOP, is applied at J43-14C and from the external PA module, AGC #2 OUTER LOOP, is applied at J43-15C.

The larger voltage of either the inner or the outer loop is used to control the AGC loop. Since the outer loop is not used in this system, the inner loop controls the AGC. R82 is adjusted so that the inner loop voltage at TP7 is larger than the voltage at TP4 by approximately .1 VDC. This ensures that the output of the exciter/amplifier is the reference used for AGC. In systems that use the outer loop, that level is adjusted to .1 VDC above the inner loops reference. This ensures that the output of the system is the reference used for AGC. If that reference drops to the point where it is smaller than the inner loop reference, the system switches over to using the inner loop reference.

The AGC reference that is being used is buffered by U10C and connected to U10D. U10D generates an output voltage that is used to bias the pin attenuators, CR2, CR3 and CR4, which sets the gain of the exciter/amplifier.

This Auto AGC circuit can be disabled by the AGC Auto/Man switch, located on the front panel, which switches the pin-attenuator bias to a variable voltage that is set by the Manual Gain Adjust.

The level-controlled RF signal, from the pin-diode attenuator circuit, is amplified by the wideband-hybrid amplifier IC U13 that is configured in the same way as U2. The RF signal is converted by T1 to a balanced, dual feed output that is applied to the push-pull Class A amplifier IC U1. Capacitors C2 and C5 provide DC blocking for the input signal to the IC. The RF outputs of the IC are applied through C3 and C4, which provide DC blocking for the output signals. The RF signals connect to combiner T2 that combines the RF back to a single-RF output at a 50 Ω impedance. The RF then enters a coupler stage, which provides a sample of the RF at J7 (-20dB), the front panel RF sample jack. The main path through coupler is to J43 pin 25B, the

Upconverter RF output jack of the module (+0 to +10 dBm).

The PLL and 10-MHz Reference section of the Board

The PLL and 10-MHz reference portion of the board utilizes either an external 10 MHz reference or an internally generated 10 MHz as the reference for the PLL circuit that generates the AFC voltage, which controls the frequency of the VCXO on the UHF Generator Board.

The (PLL) phase lock loop circuit, provides the automatic frequency control (AFC) voltage, that connects to the VCXO, located on the UHF generator board, and maintains the accurate output frequency of the VCXO. The AFC is generated by comparing a sample of the 10-MHz reference to a sample of the VCXO frequency. The PLL uses an external 10-MHz signal as the reference, unless it is missing, then an internally generated 10-MHz signal is used. The two 10-MHz reference signals are connected to the K1 relay and the selected reference connects to the comparator synthesizer IC U9. The switching between the two references is accomplished by the K1 relay. When the relay is de-energized, it applies the external 10-MHz reference to U9. The relay will remain de-energized as long as an externally generated 10-MHz reference signal is present and the Jumper W3 on J10 is placed in the external position, between Pins 1 & 2. An alternate 10 MHz reference can be connected to J11 on the board. The jumper W3 on J10 must then be moved to pins 2 & 3, internal, to connect the alternate 10 MHz to K1. The alternate 10 MHz will then act in the circuit like the external 10 MHz.

If the external 10-MHz reference is lost, the relay will energized and the internally generated 10-MHz reference is then applied through the K1 relay pin 14 to pin 1 to the IC U9.

With the relay de-energized, the externally generated 10-MHz from jack J43 pin 22B

connects through the normally closed contacts of the relay from pin 1 to pin 7 to the IC U9.

External 10-MHz Reference Present Circuitry

The external 10-MHz reference signal enters the board at J43 pin 22B and is isolated by L8 and connected to the External/Internal Jack J10. W3 on J10 is a manual jumper that must be connected between pins 1 & 2, External, for the external 10 MHz to connect to the rest of the circuit. The external 10 MHz is filtered by C44, R55, L9 and C46 before it split with one path connected to the K1 relay at pin 1 of the normally closed contacts. The other path takes the 10 MHz and rectifies it by CR5 and filters it before it is connected to U7A pin 2. If the sample level of the external 10 MHz is above the reference set by R46 and R48, which is connected to pin 3 of U7A, the output of U7A stays low. The low connects to the gates of Q3, Q5 and Q6, which are biased off and cause their drains to go high. The high from the drain of Q6 is wired to J43, pin 14A, for connection to a remote external 10-MHz present indicator. The high from the drain of Q5 connects to the yellow LED DS2, internal reference indicator, which will not light. This indicates that an external 10-MHz reference is present. The low from U7A also connects to the gate of Q3, biasing it off and causing its drain to go high. This high de-energizes the K1 relay and applies the external 10-MHz reference signal to pin 6 on U9 for use as the reference in the PLL circuits.

Internal 10-MHz Reference Circuitry

The internally generated 10-MHz reference signal connects from U6, the 10-MHz oscillator IC, to pin 14, the Normally Open contacts of relay K1.

With no external 10-MHz reference input, the level connected to U7A Pin 2 will be low. This will be less than the reference set by R46 and R48, which is connected

to pin 3 of U7A, that causes the output of U7A to go high. The high connects to the gates of Q3, Q5 and Q6, which are biased on and causes their drains to go low. The low from the drain of Q6 is wired to J43, pin 14A, for connection to a remote external 10-MHz present indicator. The low from the drain of Q5 connects to the yellow LED DS2, internal reference indicator, which will light. This indicates that an external 10-MHz reference is not present and that the internal 10-MHz is being used as the reference. The high from U7A also connects to the gate of Q3, biasing it on and causing its drain to go low. This low energizes the K1 relay and applies the internal 10-MHz reference signal through K1 pin 14 to pin 7 to pin 6 on U9 for use as the reference in the PLL circuits.

Selected 10-MHz Reference Samples

A sample of the selected 10-MHz is split off the main path through L13 and R95 using L14 and C74 and C73. The sample path connects to another splitter circuit consisting of L2, R94, L11, C71 and C70. One output of the splitter connects to J43 pin 28B that is used by the external digital modulator tray. The other output of the splitter connects to J43 pin 31B that is used by the external analog modulator tray.

Comparator Phase Lock Loop Circuit

The selected 10-MHz reference connects to pin 6, Oscillator In, of the IC U9. The LO generated by the VCXO located on the UHF Generator Board connects to J1 on the LO/Upconverter Board. A sample of the LO is divided off the main line by R105, R106 and R107. The LO sample connects to pin 4, F In, of U9.

The U9 IC takes the 10 MHz reference and divides it down to 5 kHz. It also takes the LO sample input and divides it down to 50 kHz. The two 5 kHz divided down signals are compared inside of U9 and any differences are connected to U9 pin 16. The output of U9 at pin 16 are 5 kHz pulses whose pulse width varies as any

differences between the 10-MHz and VCXO frequencies are detected. These pulses are changed to a DC voltage level by the capacitor-resistor filter network, C32, C36, C42, C38 and R49. The AFC voltage is then connected to the + input of U4B that amplifies it and connects it to jack J9. W2 on J9 must be in the operate position, between pins 1 and 2, for the PLL circuit to operate. With jumper W2 between pins 2 and 3 on J6, set up, the AFC bias is set by R43. **NOTE:** With the VCXO, located on the UHF Generator Board, set on frequency, the voltage as measured at TP2 should be -2 VDC.

The AFC output of J9 is split with one path connected to J43 pin 13A. The other path is amplified by U7B and connected to J12, VCXO AFC Output, on the board that connects to the VCXO on the UHF generator board. The PLL circuit, when locked, will maintain the very accurate VCXO output frequency because any change in frequency will be corrected by the AFC error voltage.

Lock Detector Circuit

IC chip U9 contains an internal lock detector that indicates the status of the PLL circuit. When U9 is in a locked state, pin 12 goes high; the high is applied to Q1, which is biased off. With Q1 off, pin 3 goes low and is connected to DS1, the Red Unlock LED, which does not lit. Q1 pin 3 low also connects to Q2 that is biased off. The drain of Q2, a high, is wired to J43 pin 15A, the PLL Lock Indicator output of the board.

If the 5-kHz from the 10-MHz reference and the 5-kHz from the VCXO become unlocked, out of the capture range of the PLL, pin 12 of U9 goes to a logic low that connects to the base of Q1. This biases On Q1 causing pin 3 to go high. The high connects to DS1, the red Unlock LED, which lights, and to Q2, which is biased on. When Q2 is biased on, it connects a low to jack J43 pin 15A, the PLL Lock Indicator output of the board.

Voltage Requirements

The board is powered by ± 12 VDC that is produced by an external power supply. +12 VDC enters the board through J43 pins 18A, B & C, and is filtered and isolated by L5, L6 and the shunt capacitor C24. The +12 VDC is then applied to the rest of the board and to J14 pin 3 for use by the UHF Generator Board.

One connection of the +12 VDC is to IC U12. U12 and associated circuitry produce a +9 VDC that connects to J14 pin 1 for use by the UHF Generator Board.

Another connection of the +12 VDC is to a +5 VDC regulator. The +12 VDC connects to diodes CR6 and CR7 that along with the pi type filter consisting of C56, L10, C54 and C55 removes any noise from the +12 VDC before it connects to the +5 VDC regulator IC U8. The output of the IC U8, +5 VDC, connects to the rest of the board.

The -12 VDC enters the board through J43 pins 19A, B & C and is filtered and isolated by L7 and the shunt capacitor C28. The -12 VDC is then applied to the rest of the board and to J14 pin 5 for use by the UHF Generator Board.

4.4 (A4) Control Monitoring/Power Supply Module (1301936)

The Control Monitoring/Power Supply Module Assembly contains (A1) a Power Protection Board (1302837), (A2) a 600 Watt Switching Power Supply, (A3) a Control Board (1302021), (A4) a Switch Board (1527-1406) and (A5) a LCD Display.

AC Input to Innovator LX Exciter/Amplifier Chassis Assembly

The AC input to the Innovator LX Exciter/Amplifier Chassis Assembly is connected from J1, part of a fused entry module, located on the rear of the chassis assembly to J50 on the Control

Monitoring/Power Supply Module. J50-10 is line #1 input, J50-8 is earth ground and J50-9 is line #2 input. The input AC connects to J1 on the Power Protection Board where it is fuse protected and connected back to J50, at J50-11 AC Line #1 and J50-12 AC Line #2, for distribution to the cooling Fan.

4.4.1 (A1) Power Protection Board (1302837)

The input AC connects through J1 to two 10 Amp AC fuses F1 and F2. The AC line #1 input connects from J1-1 to the F1 fuse. The AC line #1 input after the F1 fuse is split with one line connected back to Jack J1 Pin 4, which becomes the AC Line #1 to the Fan. The other line of the split connects to J4. The AC line #2 input connects from J1-3 to the F2 fuse. The AC line #2 input after the F2 fuse is split with one line connected back to Jack J1 at Pin 5, which becomes the AC Line #2 to the Fan. The other line of the split connects to J2. J1-2 is the earth ground input for the AC and connects to J3.

Three 150-VAC, for 115 VAC input, or three 275-VAC, for 230 VAC input, MOVs are connected to the input AC for protection. One connects from each AC line to ground and one connects across the two lines. VR1 connects from J4 to J2, VR2 connects from J4 to J3 and VR3 connects from J2 to J3.

+12 VDC Circuits

+12 VDC from the Switching Power Supply Assembly connects to J6 on the board. The +12 VDC is divided into four separate circuits each with a 3 amp self resetting fuse, PS3, PS4, PS5 and PS6.

The polyswitch resettable fuses may open on a current as low as 2.43 Amps at 50 °C, 3 Amps at 25 °C or 3.3 Amps at 0 °C. They definitely will open when the current is 4.86 Amps at 50 °C, 6 Amps at 25 °C or 6.6 Amps at 0 °C.

PS3 protects the +12 VDC 2 Amp circuits for the System Controller, the Amplifier Controller and the Spare Slot through J62 pins 7, 8, 9 and 10. If this circuit is operational, the Green LED DS3, mounted on the board, will be lit.

PS4 protects the +12 VDC 2 Amp circuits for the Modulator and the IF Processor through J62 pins 13, 14, 15 and 16. If this circuit is operational, the Green LED DS4, mounted on the board, will be lit

PS5 protects the +12 VDC 2 Amp circuits for the Upconverter through J62 pins 17, 18, 19 and 20. If this circuit is operational, the Green LED DS5, mounted on the board, will be lit

PS6 protects the +12 VDC 2 Amp circuits for the Remote through J63 pins 17, 18, 19 and 20. If this circuit is operational, the Green LED DS6, mounted on the board, will be lit

-12 VDC Circuits

-12 VDC from the Switching Power Supply Assembly connects to J5 on the board. The -12 VDC is divided into two separate circuits each with a 3 amp self resetting fuse, PS1 and PS2.

PS1 protects the -12 VDC 2 Amp circuits for the System through J63 pins 1, 2, 3 and 4. If this circuit is operational, the Green LED DS1, mounted on the board, will be lit

PS2 protects the -12 VDC 2 Amp circuits for the Remote through J62 pins 1, 2, 3 and 4. If this circuit is operational, the Green LED DS2, mounted on the board, will be lit

The connections from J62 and J63 of the Power Protection Board are wired to J62 and J63 on the Control Board.

4.4.2 (A3) Control Board (1302021)

In this transmitter, control monitoring functions and front panel operator

interfaces are found on the Control Board. Front panel operator interfaces are brought to the control board using a 26 position conductor ribbon cable that plugs into J60. The control board controls and monitors the Power Supply and Power Amplifier module through a 16 position connector J61 and two 20 position connectors J62 & J63.

U1 is an 8 bit RISC microcontroller that is in circuit programmed or programmed using the serial programming port J4 on the board. When the microcontroller, U1, is held in reset, low on pin 20, by either the programming port or the external watchdog IC (U2), a FET Q1 inverts the reset signal to a high that connects to the control lines of U5, an analog switch. The closed contacts of U5 connects the serial programming lines from J4 to U1. LED DS10 will be lit when programming port J4 is used.

U2 is a watchdog IC used to hold the microcontroller in reset, if the supply voltage is less than 4.21 VDC; (1.25 VDC < Pin 4 (IN) < Pin 2 (Vcc). The watchdog momentarily resets the microcontroller, if Pin 6 (ST) is not clocked every second. A manual reset switch S1 is provided but should not be needed.

Diodes DS1 through DS8 are used for display of auto test results. A test board is used to execute self test routines. When the test board is installed, Auto_Test_1 is held low and Auto_Test_2 is allowed to float at 5 VDC. This is the signal to start the auto test routines.

U3 and U4 are used to selectively enable various input and output ICs found on pages 2 & 3 of the schematic.

U1 has two serial ports available. In this application, one port is used to communicate with transmitter system components where U1 is the master of a RS-485 serial bus. The other serial port is used to provide serial data I/O where

U1 is not the master of the data port. A dual RS-232 port driver IC and a RS-485 Port driver is also in the second serial data I/O system. The serial ports are wired such that serial data input can come through one of the three serial port channels. Data output is sent out through each of the three serial port channels.

Switch SW1, transmitter operation select, is used to select either transmitter operation or exciter/driver operation. When the contacts of SW1 are closed, transmitter operation is selected and the power monitoring lines of the transmitter's power amplifier are routed to the system power monitoring lines.

U9 is a non-inverting transceiver IC that provides 2 way asynchronous communication between data busses. The IC is used as an input buffer to allow the microcontroller to monitor various digital input values.

Digital output latch circuits are used to control system devices. Remote output circuits are implemented using open drain FETs, Q13, Q14, Q16, and Q17, with greater than 60 Volt drain to source voltage ratings.

Remote digital inputs are diode protected, using CR6, CR7, CR8 and CR9 with a 1 k Ω pull-up resistor, to +5 VDC. If the remote input voltage is greater than about 2 Volts or floating, the FET is turned on and a logic low is applied to the digital input buffer, U9. If the remote input voltage is less than the turn on threshold of the FET (about 2 VDC), a logic high is applied to the digital input buffer, U9.

Four of the circuits on page two of the schematic, which include Q2, Q9, Q19 and Q21, are auxiliary I/O connections wired for future use. They are wired similar to the remote digital inputs but include a FET, Q5, Q12, Q20 and Q22, for digital output operations. To operate these signals as inputs, the associated output FET must be turned off. The FETs are

controlled by U10 and U12, analog input multiplexer ICs.

U13, U14, U15, U16, U17 and U18 are 3 state non-inverting transceiver ICs that provide 2 way asynchronous communication between data busses. The ICs are used as input buffers to allow the microcontroller to monitor various digital input values. The digital inputs to the ICs utilize a 10 k Ω pull-up resistor. The buffer IC, U18, used for data transfer to the display is wired for read and write control.

U19 and U20 are digitally controlled analog switches that provide samples back to the microprocessor. Each analog input is expected to be between 0 and 5 VDC. If a signal exceeds 5.1 VDC, a 5.1 Volt zener diode clamps the signals voltage, to prevent damage to the IC. Most signals are calibrated at their source, however two dual serial potentiometers ICs are used to calibrate four signals, System Visual/Average Power, System Aural Power, System Reflected Power and the Spare AIN 1. For these four circuits, the input value is divided in half before it is applied to an op-amp. The serial potentiometer is used to adjust the output signal level to between 80 and 120% of the input signal level. Serial data, serial clock and serial pot enables are supplied by the microprocessor to the dual serial potentiometer ICs. J62 and J63 are two 20 position connectors that provide the +12 VDC and -12 VDC power through the Power Protection Board. The ± 12 VDC generated by the switching power supply connects to J62 and J63 after being fuse protected on the Power Protection Board.

There are three dual element, red/green, common cathode LED indicators mounted on the front panel of the sled assembly; DC OK, Operate and Fault.

There are three, the fourth is a spare, identical circuits that drive the front

panel mounted LED indicators. The levels on the 1, 2, 3 and 4 LED Control Lines, for both the red and green LEDs, are generated by the IC U11 as controlled by the DATABUS from the microprocessor U1.

Each LED controller circuit consists of an N-Channel MOSFET w/internal diode that controls the base of an N-P-N transistor in an emitter follower configuration. The emitter of the transistor connects the LED.

With the LED control line LOW, the MOSFET is Off, which causes the base of the transistor to increase towards +12 VDC, forward biasing the transistor. With the transistor forward biased, current will flow from ground through the LED, the transistor and the current limiting resistors in the collector to the +12 VDC source. The effected LED will light.

With the LED control line HIGH, the MOSFET is On, which causes the base of the transistor go toward ground potential, reverse biasing the transistor. With the transistor reverse biased, no current through the transistor and LED, therefore the effected LED will not light.

A third color, amber, can also be generated by having both transistors conducting, both control lines LOW. The amber color is produced because the current applied to the green element is slightly greater than the red element. This occurs because the current limiting resistors have a smaller ohm value in the green circuit.

There are four voltage regulators, three for +5 VDC and one for +7 VDC, which are used to power the Control Board. +12 VDC is applied to U25 the +7 VDC regulator that produces the +7V, which is applied to the LEDs mounted on the board. The +7V is also connected to the input of U26 a precision +5.0 Volt regulator. The +5.0Vdc regulator output is used to power the analog circuits and as the microcontroller analog reference voltage. Another two +5 Volt regulator

circuits U27, +5V, and U8, +5 Vserial, are used for most other board circuits.

4.4.3 (A4) Switch Board (1527-1406)

The switch board provides five front-panel momentary contact switches for user control and interface with the front-panel LCD menu selections. The switches, SW1 to SW5, complete the circuit through connector J1 to connector J2 that connects to J1 on (A5) the 20 Character by 4 line LCD Display. J1 on the switch board is also cabled to the Control Board. When a switch is closed, it connects a logic low to the control board that supplies the information from the selected source to the display. By pushing the button again, a different source is selected. This occurs for each push button. Refer to Chapter 3 Section 3.5.4, for more information on the Display Menu Screens.

4.4.4 (A2) Switching Power Supply Assembly

The power supply module contains a switching power supply, an eight position terminal block for distributing the DC voltages, a three position terminal block to which the AC Input connects, Jacks J1, V1 and V2. Jack J1 connects to the Control Board and supplies DC OK, at J1-4 & 3, and AC OK, at J1-2 & 1, status to the control board. A Power Supply enable connects from the control board to the power supply at V1-6 & 7. The power supply is configured for three output voltages +12V, -12V, at the 8 position terminal block, and a main output power of +32 VDC at J50 pin A (+) and J50 pin B (Rtn). The power supply is power factor corrected to .98 for optimum efficiency and decrease in energy consumption. For safety purposes all outputs are over voltage and over current protected. This supply accepts input voltages from 85 to 264 volts AC, but the power entry module, for the exciter/amplifier chassis, must be switched to the proper input

voltage setting, for the transmitter to operate.

4.5 (A4) Power Amplifier Module Assembly (1301923)

The Power Amplifier Module Assembly contains (A1) a 1 Watt UHF Amplifier Module Assembly (1302891), (A2) a 40 Watt UHF Module Assembly (1206693), (A3) UHF RF Module Pallet Assembly (1300116), (A4) a Coupler Board Assembly (11301949), (A5) an Amplifier Control Board (1301962) and (A6) a Temperature Sensor IC.

The RF from the Upconverter Module Assembly connects from the Upconverter RF Output BNC Jack J23, through a cable, to the PA RF Input BNC Jack J24, located on the rear of the exciter/amplifier chassis assembly.

4.5.1 (A1) 1-Watt UHF Module Assembly (1302891)

The 1-watt UHF module assembly provides radio frequency interference (RFI) and electromagnetic interference (EMI) protection, as well as the heatsink, for the 1-watt UHF amplifier board (1302762) that is mounted inside the assembly. The assembly has approximately 17 dB of gain.

The RF input to the assembly connects to SMA Jack J3. The amplified RF output of the assembly is at the SMA Jack J4. Typically, with an input signal of +4 dBm at J1 of the assembly, an output of +21 dBm can be expected at J2.

The +12-VDC bias voltage connects through J5, a RF-bypassed, feed-through capacitor, to the amplifier board. The -12-VDC bias voltage connects through J6, a RF-bypassed, feed-through capacitor, to the amplifier board. E1 on the assembly connects to Chassis ground.

4.5.2 (A1-A1) 1-Watt UHF Amplifier Board (1302761)

The 1-watt UHF amplifier board is mounted in the 1-watt UHF amplifier assembly (1302891) and provides approximately +17 dB of gain.

The UHF signal enters the board at J3, a SMA connector, and is applied to U3 an IC hybrid coupler assembly that splits the input signal into two equal parts. The two amplifier paths are identical using Q4 and Q5, 1-Watt HFETs as the amplifier devices. Each HFET has approximately 14 dB of gain.

The drain voltage needed to operate each HFET is obtained from the +12 VDC line that connects to the board at J5 and is regulated down to +8.25 volts by U4. The gate negative bias voltage is obtained from the -12 VDC line that connects to the board at J6.

The amplified outputs of the HFETs are applied to U2 an IC hybrid coupler assembly that combines the amplified signals into a single output that connects to J4 of the board.

4.5.3 (A4-A1) 40 Watt UHF Amplifier Assembly (1206693)

The output of the UHF filter is connected to the input J1 of (A2) the 40 Watt UHF

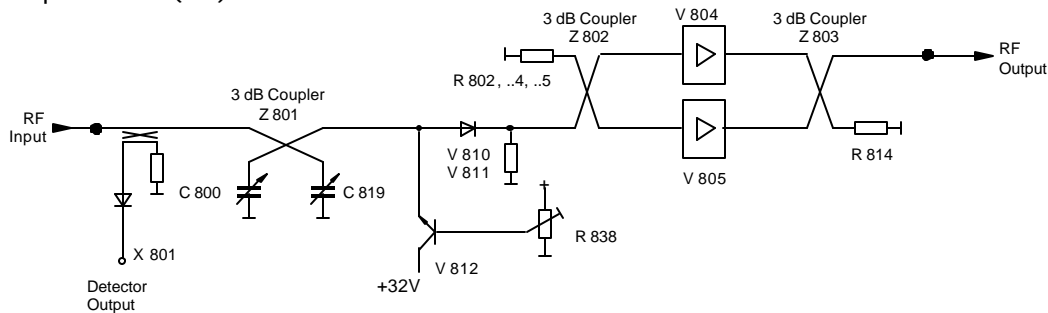

Figure 4-1: 40 Watt UHF Amplifier Module

4.5.4 (A3) UHF Module Assembly, RF Module Pallet, Philips (1300116)

The UHF Module Assembly, 250-watt module (Figure 4-2) is a broadband amplifier for the frequency range 470 to 860 MHz. The amplifier is capable of delivering an output power of 70 W_{rms} .

amplifier assembly (Figure 4-1). The assembly is made up of a (51-5378-308-00) module, which operates class AB and is a highly linear broadband amplifier for the frequency range of 470 to 860 MHz. It can deliver an output power of 40 watts (CW) with approximately 14 dB of gain.

The amplification circuit consists of LDMOS transistors V804 and V805 connected in parallel and operating in class AB. The paralleling network is achieved with the aid of 3 dB couplers Z802 and Z803. A further 3 dB coupler Z801, in conjunction with capacitors C800 and C819, serves as a phase shifter. Phase alignment (for the complete amplifier), as well as quiescent current settings are achieved by means of potentiometers R807 and R808. The settings are factory implemented and should not be altered.

PIN diodes V810 & V811 form a variable-damping circuit that is used to adjust the amplification of the 40-watt module. The adjustment is performed with the Gain potentiometer R838. A readjustment of the amplification may be required, after repair work, to ensure that the PAs in multiple PA transmitters deliver the same output power

The amplification is approximately 13 dB.

The amplification circuit consists of the parallel connected push-pull amplifier

blocks V1 and V2 operating in class AB. In order to match the transistor impedance to the characteristic impedance of the

input and output sides, matching networks are placed ahead and behind the amplifier blocks. Transformers Z3 to Z6 serve to balance the input and output signals. The paralleling circuit is achieved with the aid of 3-dB couplers Z1 and Z2.

The working point setting is factory implemented by means of potentiometers R9, R11, and R12 and should not be altered.

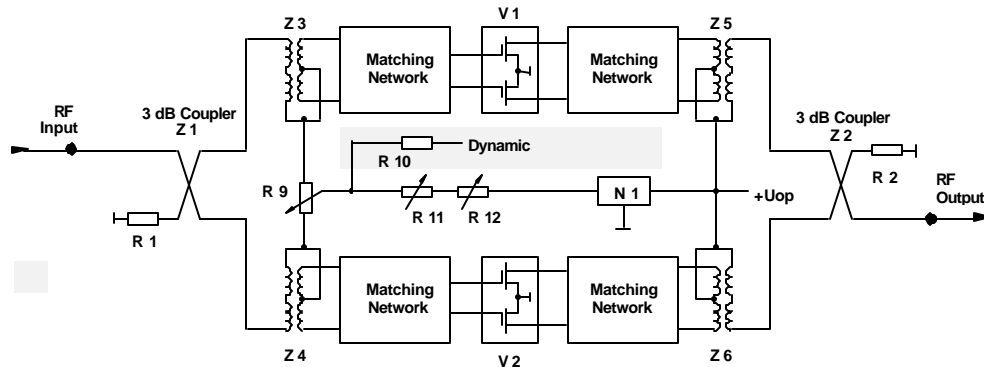

Figure 4-2. UHF Amplifier Module, 250 Watts

4.5.5 (A4) Coupler Board Assembly (1301949)

The UHF coupler board assembly provides a forward and reflected power samples of the output to (A5) the amplifier control board where it connects to the input of the overdrive-protection circuit.

The RF input to the UHF coupler assembly, from the 250 Watt UHF amplifier module, connects to SMA jack J1. The RF is connected by a stripline track to the SMA type connector RF Output jack J2. A hybrid-coupler circuit picks off a power sample that is connected to SMA type connector jack J3 as the forward power sample. Another power sample is taken from the coupler circuit that is connected to SMA type connector jack J6 as the reflected power sample. Two 50Ω terminations, used as dissipation loads, connect to the reject and reflected ports, J5 and J4, of the coupler.

4.5.6 (A5) Amplifier Control Board (1301962)

The amplifier control board provides LED fault and enable indications on the front panel of the module and also performs

the following functions: overdrive cutback, when the drive level reaches the amount needed to attain 110% output power; and overtemperature, VSWR, and overdrive faults. The board also provides connections to the LCD Display for monitoring the % Reflected Power, % Output Power, and the power supply voltage.

U4, located upper center of page, is an in circuit microcontroller. The controller is operated at the frequency of 3.6864 MHz using crystal Y1. Programming of this device is performed through the serial programming port J2. U4 selects the desired analog channel of U1 through the settings of PA0-PA3. The outputs of Port A must be set and not changed during an analog input read of channels PA5-PA7. PA4 of U4 is a processor operating LED that monitors the +/- 12 VDC. PA5 is used to monitor the +12VDC supply to the board. PA6 is the selected channel of analog switch U1. PA7 is connected to a via, V10, for future access.

U6 is a serial to RS-485 driver IC. U7 is a watchdog IC used to hold the microprocessor in reset, if the supply voltage is less than 4.21 VDC. U7 momentarily resets the microcontroller if Pin 6 (!ST) is not clocked every second. A

manual reset switch is provided but should not be needed.

Upper left corner U3 is used to determine where the amplifier control board is located. The eight inputs come from the main amp connector and are used to set the SCADA address of the controller. Pull-up resistors set a default condition of logic high.

U5 below U3 is used for getting digital input information of the board. Page two has several monitoring circuits that provide information on the amplifier's status. Many of these circuits automatically shut down the amplifier if a specific fault occurs.

U8 below U5 is used to control four board mounted status LEDs. A FET is turned On to shunt current away from the LED to turn it Off. U9 below U8 is used to enable different features within the software. Actual use is to be determined.

In the lower right corner are voltage regulator circuits. U22 should allow for 0.14 amps of power using its 92 C/W rating if $T_a = 60^\circ\text{C}$ max and $T_j = 125^\circ\text{C}$ max. 0.26 amps can be obtained from U22 if the mounting pad is 0.5 square inches. The controller will not need this much current.

U23 and U24 are low drop out +5 VDC, voltage regulators with a tolerance greater than or equal to 1%. 100mA of current is available from each device but again the controller will not need this much current.

In the upper left section are circuits with U12 and U13. U12 is used to generate a regulated voltage that is about 5 volts less than the +32 VDC supply, approximately +26.25 VDC. When the +32 VDC supply is enabled, the circuitry around U13B is used to provide gate voltage to Q10 that is 5 volts greater than the source pin of this FET. The gate of Q10 can be turned Off by any one of a few different circuits.

U10A is used to turn Off the gate of Q10 in the event of high current in amplifier #1. At 0.886 VDC the current to amplifier #1 should be greater than 5 Amps. U11B is used to turn off the Q10 FET, if high current is detected in amplifier #2. U11A is used to turn off the Q10 FET, if high current is detected in amplifier #3. With 2.257 VDC at Pin 5 of U11B or Pin 3 of U11A, the voltage output of current sense amplifier U17 or U18 at high current shut down should be greater than 15 Amps.

U14B is used to turn Off the gate of Q10 in the event of high power supply voltage, approximately +35.4 VDC. U14A is used to keep the FET disabled in the event of low power supply voltage, approximately +25.4 VDC.

Current monitoring sections of the board.

The ICs U16, U17 and U18 along with associated components set up the current monitoring sections of the board. R67, R68 and R69 are 0.01 Ω /5W 1% through hole resistor is used for monitoring the current through several sections of the amplifier. The voltage developed across these resistors are amplified for current monitoring by U16, U17 or U18. The LT1787HVCS8 precision high side current sense IC amplifier accepts a maximum voltage of 60 VDC. The 43.2 k Ω resistor from pin 5 to ground sets the gain of the amplifier to about 17.28. This value is not set with much accuracy since the manufacturer internally matches the resistors of this part but their actual resistance value is not closely defined. A trimming resistor is suggested to give a temperature stability of -200 ppm/C, but instead the microcontroller will determine the exact gain of the circuit and use a correction factor for measurements. Circuit loading components are located in the lower portion of each current monitoring circuit. These components allow for short duration high current loading of the supply. By measuring the current through the sense resistor with and without the additional four 30.1 Ω 1%

resistors. For very short duration pulses, a 1206 resistor can handle up to 60 watts. The processor requires 226 uSec per conversion. A supply voltage of +32 VDC will pass 1.06 amps + 1% through the load resistors.

A6 is a temperature sensor thermistor that is used to monitor the temperature of the module's heat sink. It connects to J6 pins 1 & 2 on the board and is wired to the comparator IC U10B. If the temperature increases above 75°C the output will go Low that is used as a temperature fault output, which generates a Fault alert at U15A and disables Amplifier #1.

Aural, Visual/Average and Reflected power detector sections of the board.

A Forward Power Sample enters the board at SMA Jack J3 and is split. One part connects to J4 on the board that is cabled to J1, the SMA Forward Power Sample Jack, located on the front panel of the assembly. The other part of the split forward power sample is detected by CR17 and the DC level amplified by U25A. The output of U25A at pin 1 is split with one part connected to the Aural Power sample, which is not used in this digital transmitter. The other split output connects to U265A that is part of the Forward Average Power circuit. The detected level is connected to L4 that is part of an intercarrier notch filter circuit that is tuned to eliminate the 4.5 MHz aural intercarrier, if present. The Average power sample is amplified by U26D and connected through the average calibration pot R166 to U26C. The output of U26C is connected to the comparator IC U26B that has Aural Null and Offset Null, if present in the system,

connected to the other input. The output Average Forward power level connects to J9 pin 2 of the board.

A Reflected Power Sample enters the board at SMA Jack J5 and is detected by CR20 and the DC level amplified by U28B. The output of U28B at pin 7 is connected through the reflected calibration pot R163 to U28C. The output is split with one part connected to J9 pin 5, the Reflected Power Output level of the board. The other part of the split from U28C connects to the comparator IC U28D that has a reference level connected to the other input. If the reflected level increases above the reference level a low output is produced and connected to the Reflected Power Shutdown circuit at CR28. The low shuts off Q14 causing pin 3 to go high that is connected to the inverter U15C. The output of U15C goes low producing a Reflected Power Fault that is connected to an output of the board, the Fault Alert circuit and also shuts down Amplifier #1.

Gain of the power measurements is completed through software. Only the Aural Null and Offset Null need to be done through front panel pots.

This completes the description of the Power Amplifier Module Assembly and the Exciter/Amplifier chassis assembly.

Bandpass Filter and Trap Filter

The output of the translator is fed to (A9) a Bandpass Filter, (A10) an Output Trap Filter Assembly, and finally to the Antenna for your System. The Bandpass Filter and Trap Filter are tuned to provide high out of band rejection of unwanted generated products.

Chapter 5

Detailed Alignment Procedures

This translator was aligned at the factory and should not require additional adjustments to achieve normal operation.

This translator takes the On channel RF input to the Receiver Tray and converts it to the desired UHF On Channel RF Output at the systems output power level.

If the (Optional) Modulator Kit is purchased, this translator can also operate using the baseband audio and video inputs or, if the (Optional) 4.5-MHz composite input kit is purchased, either a single composite video + 4.5-MHz input or separate baseband video and audio inputs.

The exciter/amplifier of the Innovator LX Series translator is of a Modular design and when a Module fails that module needs to be changed out with a replacement module. The replacement module can then be sent back to Axcera for repair. Contact Axcera Customer Service Department at 724-873-8100 or fax to 724-873-8105, before sending in any module.

Module Replacement

Module replacement on the Innovator LX Series products is a relatively simple process. All modules plug directly into the backplane board except for the power amplifier module, and in higher power units, the power supply and power amplifier modules, that plug into a blind mating connector. To replace a module, refer to the following procedure.

Loosen the two grip lock connectors, located on the front panel, at the top and bottom of the module, counterclockwise until the module releases. The IF Processor, Upconverter and Controller/Power Supply can then be gently pulled from the unit. There are two cables connected to the rear of

the Power Amplifier Module in the exciter/amplifier chassis assembly. These two cables must first be removed before the PA module will slide out.

Slide the new module in place and make certain it connects to the backplane board. If the new module is a PA Module replace the two cables on the rear of the exciter/amplifier chassis assembly. If the new module does not slide in easily, verify it is properly aligned in the nylon tracks both top and bottom.

Note: Each Module has an assigned slot and will not fit properly in the incorrect slot. Do not try to place a Module in the wrong slot as this may damage the slot or the connectors on the backplane board.

Each module has the name of the module on the front, bottom for identification and correct placement. The Modules are placed in the unit from left to right; (1) Blank panel, (2) Modulator (for transmitters) or a Blank panel for a Translator, (3) IF Processor, (4) Upconverter, (5) Controller/Power Supply and (6) Power Amplifier.

Initial Test Set Up

Check that the RF output at the coupler is terminated into a dummy load of at least 100 watts. While performing the alignment, refer to the Test Data Sheet for the translator and compare the final readings from the factory with the readings on each of the modules or tray. The readings should be very similar. If a reading is way off, the problem is likely to be in that module or tray.

Switch On both the main AC for the system and the ON/OFF circuit breaker located on the rear of the Receiver Tray.

5.1 UHF/VHF Receiver Tray. (1142479 or 1265-1100)

Connect a UHF or VHF Input that is at the desired Channel Frequency, to J1 50Ω or J5 75Ω located on the rear of the (A7) VHF/UHF Receiver Tray. Check that the On/Off Switch located on the rear of the Tray is On.

Note: If the Red LED, DS1 is lit, +12 VDC is present at the input of the Receiver Tray and may damage any test equipment connected to it. Remove the fuse F1, DS1 will not be lit, before connecting test equipment to the input jack of the Receiver Tray.

5.1.1 (A7) UHF Filter, DC Multiplexed (1035-1204, 50W or 1035-1207, 75W), VHF Filter, LB, DC Multiplexed (1035-1902, 50W or 1035-1903, 75W) or VHF Filter, HB, DC Multiplexed (2065-1024, 50W or 2065-1023, 75W)

The input UHF or VHF signal (-61 dBm to -16 dBm) is fed to the filter which has been factory swept for 6 MHz Bandwidth at the Channel frequency and should not be tuned in the field. The output of the filter is directed to the J1 input of (A8) the Dual Stage Amplifier Assembly.

5.1.2 (A8-A1) Dual Stage Amplifier Board (1227-1501)

Mounted in: (A8) a Dual Stage Amplifier Assembly (1227-1503).

The Dual Stage Amplifier Board has been factory set to the channel frequency and contains no customer tuning adjustments. The board has approximately +13 dB or +26 dB of gain, depending on whether Jumper W1 on J5 is in place.

5.1.3 (A9) UHF Filter (1007-1101), VHF LB Filter (1034-1202) or VHF HB Filter (2065-1000)

The UHF or VHF Filter has been factory swept for 6 MHz Bandwidth at the

Channel Frequency and should not be tuned in the field. The output of the filter (-50 dBm to -5 dBm) is fed either through the additional amplifier stage on the Variable Gain Amplifier Board or to (A10-A1) the Downconverter/Filter Board.

5.1.4 (A4) Channel Oscillator Assembly, Dual Oven (1145-1202)

Contains: The Channel Oscillator Board, Dual Oven (1145-1201).

1. Connect the main output of the Channel Oscillator (J1) to a spectrum analyzer, adjusted to view the crystal frequency. Peak the tuning capacitors C6 and C18 for maximum output. Then tune L2 and L4 for maximum output. The output level should be approximately +5 dBm and the Oven Temperature should be maintained at 50°C.

If a spectrum analyzer is not available, connect a DVM to TP1 on the x8, x4 or x2 Multiplier Board. Tune capacitors C6 and C18 for maximum voltage at TP1. Then tune L2 and L4 for maximum voltage at TP1.

2. Connect the sample output of the Channel Oscillator at J2 to a suitable counter and tune C11, Coarse Adjust, and C9, Fine Adjust, to the crystal frequency. Do not re-peak C6, C18, L2 or L4 because this may change the output frequency.

Note: While adjusting C9 and C11 to the crystal frequency the peak voltage monitored at TP1 of the Multiplier Board should not decrease. If a decrease does occur a problem with the crystal is likely.

3. Reconnect the main output at J1 of the Channel Oscillator to the Input Jack J1 of the Multiplier Board.

Note: If the Optional Frequency Correction Kit is purchased a VCXO Assembly (1145-1206), containing a VCXO Board (1145-1204), will be used instead of the standard Channel Oscillator Board. The adjustment will be the same as above except that the frequency is adjusted by moving the Jumper W1 on Jack J6, located on the IF PLL Board (1109-1002), to Pins 2 & 3, Fixed Bias, and adjusting R15 on the IF PLL Board for -3 VDC at FL2 of the VCXO Assembly. Move the Jumper W1 on Jack J6 to between Pins 1 & 2, AFC. Connect the Oscillator Sample output, at (J2) of the Channel Oscillator or the Front Panel Sample Jack (J9), to a suitable Frequency Counter and tune C11, Coarse Adjust, to the desired frequency. Do not re-peak C6, C18, L2 or L4 because it may change the output frequency.

Reconnect the main output (J1) of the Channel Oscillator (+5 dBm) to the input (J1) of the Multiplier Board. DS1 the Red Unlock Indicator, located on the IF PLL Board, should not be lit.

5.1.5 (A5-A1) x8 Multiplier Board (1227-1002), x4 Multiplier Board (1227-1525) or x2 Multiplier Board (1227-1524)

Mounted in (A5) a Multiplier Enclosure (1265-1125).

During Normal operation, the Green LED DS1, which can be seen through the access hole in the Enclosure Assembly, will be lit to indicate that the L.O. is present at the output of the x8 Multiplier Board.

1. Connect a Spectrum Analyzer to the Output Jack (J2) of the board.
2. Tune C4, C6, C10, C12, C18 and C20 on the x8 and the appropriate caps on the other boards for maximum output. Readjust all the

Capacitors to minimize the seventh and the ninth harmonics, they should be at least -30 dB down, without affecting the x8 Multiplier Output.

If a Spectrum Analyzer is not available a DC voltmeter can be used as follows but the harmonic frequencies must be minimized to prevent interference with other Channels.

1. While Monitoring each Test Point with a DC voltmeter, maximize the voltage by tuning the Broadband Multipliers in the following sequence.
2. For x8 Multiplier Board: Monitor TP1 with a DVM and tune C4 for maximum. (Typical .6 VDC)
Monitor TP2 and tune C6 and C10 for maximum. (Typical 1.2 VDC)
Monitor TP3 and tune C12 and C18 for maximum. (Typical 2 VDC)
Monitor TP4 and tune C20 for maximum. Re-peak C12 and C10 while monitoring TP4. (Typical 3.5 VDC)

For x4 Multiplier: Monitor TP1 with a DVM and tune C4 for maximum. (Typical .6 VDC)
Monitor TP2 and tune C6 and C10 for maximum. (Typical 1.2 VDC)
Monitor TP3 and tune C12 for maximum. Re-peak C12 and C10 while monitoring TP3. (Typical 2 VDC)
For x2 Multiplier: Monitor TP1 with a DVM and tune C4 for maximum. (Typical .6 VDC)
Monitor TP2 and tune C6 for maximum. Re-peak C4 and C6 while monitoring TP2. (Typical 1.2 VDC)

The Green LED DS1 should be lit which indicates that the L.O. is present at the Output Jack J2 of the Multiplier Board. The output of the Multiplier at J2 is connected to (A6) a UHF or VHF Filter.

5.1.6 (A6) UHF Filter (1007-1101), VHF LB Filter (1034-1211) or VHF HB Filter (2065-1000)

This filter has been factory swept at the L.O. frequency and should not be tuned without proper equipment. The output of the filter (+15 dBm) is connected to J2 on (A10) the Downconverter/Filter Assembly.

5.1.7 (A10-A1) Downconverter/Amplifier Board (1227-1502)

Mounted in: The (A10) Downconverter/Amplifier Assembly (1227-1505).

The Mixer contains no adjustments and has a L.O. input of approximately +12 dBm in level applied to J2 and a -47 dBm to -2 dBm RF input applied to J1. The output IF level at J3 will be -55 dBm to -10 dBm.

1. Connect a Spectrum Analyzer to the Output Jack J3 and adjust L1, C2 and L3 for best frequency response.
2. Adjust C8 and R3 to notch out the Aural IF Frequency.

The IF output at J3 (-55 dBm to -10 dBm) is fed to the IF Filter/ALC Board. If needed a 10 dB Pad can be added to the circuit by moving the jumpers on J4 and J5 to the In position.

5.1.8 (A11-A1) IF Filter/ALC Board (1227-1504) Mounted in: The (A11) IF Filter/ALC Enclosure (1265-1105).

1. Check that Switch S1, located on the IF Filter/ALC Board, is in the Auto ALC and that the output of the Board at J2 is approximately 0 dBm Output, adjust R23 if needed.

5.1.9 (A11-A2) (Optional) SAW Filter/Amplifier Board (1035-1211)

Mounted in: The (A11) IF Filter/ALC Enclosure (1265-1105).

This board is used for additional adjacent Channel rejection only if needed and may not be part of the Tray.

The board contains no tuning adjustments. The Jumpers W1 and W2 on J4 and J5 are placed for Attenuator In or Attenuator Out as needed to give the same output level at J2 as was at J1.

5.1.10 (A2) $\pm 12V$ Power Supply Board (1092-1206)

This board contains no adjustments.

Note: If the (Optional) Frequency Corrector Kit is part of the tray, perform the following adjustments. If the Frequency Corrector Kit is not part of the tray, the tray is aligned and ready for normal operation.

5.1.11 (A15) (Optional) IF Carrier Oscillator Board (1100-1206)

1. Monitor J3 with a Spectrum Analyzer and observe the 38.9 MHz Visual IF signal at +5 dBm.
2. Connect a Frequency Counter to J2 on the board or to J9 on the Front Panel and adjust C17 for 38.9 MHz.
3. Connect a Frequency Counter to J1 and check for the 50 kHz signal. Adjust C17, if needed, to attain the 50 kHz frequency. Remove the Jack on J5. DS2 the Unlock Indicator should light. Replace the Jack onto J5.

5.1.12 (A13) (Optional) IF Filter/Limiter Board (1109-1001)

1. Monitor the Aural Notch Test Output of the board at J5 and move the Jumper W1 on Jack J4 to between Pins 2 & 3, Test Position. Adjust C17 to the Aural IF Frequency, then adjust R10 to

eliminate or minimize the Aural IF signal. Move the Jumper W1 on Jack J4 back to between Pins 1 & 2, Operate Position.

2. Monitor the IF CW Output of the board at J6 with an Oscilloscope and adjust R12 and C21 for maximum Video Signal or connect a Spectrum Analyzer, in Zero Span, to J6 and adjust R12 and C21 for Minimum Video Signal amplitude ripple on the displayed signal.
3. Adjust R15 for +3 dBm or Maximum output level if +3 dBm cannot be attained.

5.1.13 (A14) (Optional) IF PLL Board (1109-1002)

Check that the Red LED DS1, Unlock Indicator, located on the board is not lit.

If DS1 is lit, follow the alignment procedure for setting up the VCXO Channel Oscillator using R9 on the IF PLL Board to set up the AFC Voltage for the Frequency of the VCXO. If it is still lit, check the 50 kHz reference output of the (A15) IF Carrier Oven Oscillator. If needed, follow the alignment procedure for the IF Carrier Oven Oscillator Board.

5.1.14 (A16) (Optional) IF Amplifier Board, High Gain (1197-1126)

This board contains no customer adjustments. The amplified IF output from the IF Filter/ALC Board connects to the IF Filter Limiter Board.

The Receiver Tray is now set up and ready for normal operation.

5.2 Innovator LX Series Exciter/Amplifier Chassis Assembly

The exciter/amplifier chassis assembly operates using an external IF input from an external receiver tray. The IF source connects to J6, the modulated IF Input jack, on the rear of the chassis assembly, which is cabled to the IF Processor Module.

On the LCD Display, located on the Controller/Power Supply Module, push the button to switch the translator to Operate. The setup of the RF output includes adjustments to the drive level of the Power Amplifier, the adjustment of the linearity and phase predistortion to compensate for any nonlinear response of the Power Amplifier on the front panel of the IF Processor module.

Verify that all red LEDs located on the IF Processor front panel are extinguished. The following details the meaning of each LED when illuminated:

- DS1 (input fault) – Indicates that either abnormally low or no IF is present at the input of the module.
- DS2 (ALC fault) – Indicates that the ALC circuit is unable to maintain the signal level requested by the ALC reference. This is normally due to excessive attenuation in the linearity signal path or the IF phase corrector signal path, or that switch SW1 is in the Manual ALC Gain position.
- DS4 (Mute) – Indicates that a Mute command is present to the system.

Switch the translator to Standby. The ALC is muted when the translator is in Standby. To monitor the ALC, preset R3, manual gain adjust, on the front panel of the Upconverter module, fully CCW. Move switch SW1, Auto/Man AGC, on the front panel of the Upconverter module, to the Manual position. Place the translator in Operate. Adjust the ALC GAIN pot on the front panel of the IF Processor to

obtain +0.8 VDC on the LCD Display on the Controller/Power Supply in the ALC screen. Move the MAN/AUTO ALC switch back to Auto, which is the normal operating position.

To adjust the AGC Cutback setting, raise the output power of the translator to 110%. Adjust R2, AGC Cutback, located on the front panel, CCW until the LED DS1, AGC Cutback, just starts to flash. Return the output power of the translator to 100%.

5.2.1 Linearity Correction Adjustment

As shipped, the exciter was preset to include amplitude and phase pre-distortion. The pre-distortion was adjusted to approximately compensate the corresponding non-linear distortions of the Power Amplifier.

NOTE: On the IF processor board inside the module the correction enable/disable jumper W12 on J30 will be in the Enable position, on pins 2 & 3.

Set up a spectrum analyzer with 100 kHz resolution bandwidth and 100 kHz video bandwidth to monitor the intermodulation products of the RF output signal of the Power Amplifier. A typical red field spectrum is shown in Figure 5-1. There are three Linearity Corrector stage adjustments located on the front panel of the IF Processor Module. The adjustments are threshold settings that are adjusted as needed to correct for any amplitude or phase intermod problems. Adjust the top linearity correction adjustment R211 threshold cut in for the in phase amplitude distortion pre-correction that is needed. Next adjust the middle linearity correction adjustment R216 threshold cut in also for the in phase amplitude distortion pre-correction that is needed. Finally adjust the bottom linearity correction adjustment R231 threshold cut in for the quadrature phase distortion pre-correction that is needed. The above

pots are adjusted for the greatest separation between the peak visual

carrier and the intermod products.



Figure 5-1. Typical Red Field Spectrum

5.2.2 Frequency Response Delay Equalization Adjustment

The procedure for performing a frequency response delay equalization adjustment for the translator is described in the following steps:

The center frequency for the first stage is 46.5 MHz. Adjust R103, the top frequency response equalizer pot, located on the front panel of the IF Processor Module, for the best depth of frequency response correction at 46.5 MHz.

The center frequency for the second stage is 41.5 MHz. Adjust R106, the middle frequency response equalizer pot, located on the front panel of the IF Processor Module, for the best depth of frequency response correction at 41.5 MHz.

The center frequency for the second stage is 44 MHz. Adjust R274, the bottom frequency response equalizer pot, located on the front panel of the IF Processor Module, for the best depth of frequency response correction at 44 MHz.

After the three delay attenuation equalizers have been adjusted, fine tune, as needed, for the best frequency response across the channel.

5.2.3 Calibration of Output Power and Reflected Power of the translator

Note: Perform the following procedure only if the power calibration is suspect.

Switch the transmitter to Standby and preset R205, the aural null pot on the Amp Control board, fully CCW. Adjust R204, the null offset pot on the Amp Control board, for 0% visual output. Perform the following adjustments with no aural present by removing the aural carrier from the test modulator. Connect a sync and black test signal to the video input jack of the test modulator. Switch the transmitter to Operate.

Next, set up the transmitter for the appropriate average output power level:

- Sync + black 0 IRE
setup/wattmeter=59.5 watts
- Sync + black 7.5 IRE
setup/wattmeter=54.5 watts

Note: The transmitter must have 40 IRE units of sync.

Adjust R202, visual calibration, on the Amp Control board for 100% on the front

panel display in the % Visual Output position.

With the spectrum analyzer set to zero span mode, obtain a peak reference on the screen. Reconnect the aural carrier from the test modulator. Turn the power adjust pot on the front panel until the original peak reference level is attained. Adjust R203 for a 100% aural power reading. Switch to the Visual Output Power position and adjust R205 (aural null pot) for 100% visual power.

To calibrate the reflected output power reading of the translator. Reduce manual gain pot R3 to a 10% reading on the LCD front panel display in the % Output Power position. Place the translator in Standby. Remove the load from J4 on the (A4) Direction Coupler Board and switch the LCD Display screen to the Reflected Output Power position. Switch the translator to operate. Adjust the reflected power calibration adjust pot R163 on the power amplifier module to a 10% reading. Reconnect the load to J4.

After this calibration is completed, move switch SW1 on the upconverter module to the Automatic AGC position. This is the normal operating position for the switch.

The Translator is now aligned, calibrated, and ready for normal operation.

This completes the detailed alignment procedures for the Innovator LX Series translator.

If a problem occurred during the alignment, help can be found by calling Axcera field support at 724-873-8100.

5.3 Alignment Procedure for the Bandpass Filter Assembly

The Bandpass Filter Assembly is tuned to reject unwanted distortion products generated when the signals are dplexed and also during the amplification process.

The Bandpass Filter is factory tuned to the proper bandwidth and should not need tuned. If you think tuning is needed consult ITS Corp. Field Support Department before beginning.

The Traps are labeled with their Center Frequency relative to the Frequency of the Carrier. (For Example: The Traps labeled -4.5 MHz are tuned for a Center Frequency of 4.5 MHz Lower than the Frequency of the Visual Carrier.)

The Trap Sections are Reflective Notches, adjustable across the entire UHF Frequency Band. The electrical length of the Outer Sleeve and the Center Rod of the Notch can be adjusted to Tune the Notch Frequency. The Depth of the Notch is set by the gap between the Center Conductor of the Trap Section and the Center Conductor of the Main Line. Tight Coupling makes a Deep Notch, while Loose Coupling makes a Shallow Notch.

The Trap Sections have been factory tuned and should not need major adjustments. The Frequency, relative to Visual Carrier, that the Trap is tuned to is marked on the Notch. Fine Tuning of the Notches Center Frequency can be accomplished with the Tuning Bolts located on the side of the Filter Section. Loosen the nut locking the Bolt in place and adjust the Bolt to change the Frequency of the Notch. Monitor the output of the Transmitter with a Spectrum Analyzer and Null the Distortion Product with the Bolt. Red Field is a good Video Test Signal to use to see the +8.08 MHz Product. Tighten the nut when the tuning is completed. Hold the bolt in place with a screwdriver as the nut is tightened to prevent it from slipping.

For major tuning, such as changing the Notch Depth or moving the Notch Frequency more than 1 MHz, the Outer Conductor and the Center Conductor of the Trap Section must both be moved. This requires an RF Sweep Generator to

accomplish. Apply the Sweep signal to the Input of the Trap Filter and monitor the Output. Loosen the Clamp holding the Outer Conductor in place and make the length longer to Lower the frequency of the Notch or shorter to Raise the frequency of the Notch. Loosen the Center Conductor with an Allen Wrench and move it Deeper for a Lower Frequency Notch or out for a Higher Frequency Notch. These adjustments must both be made to change the Notch Frequency. Moving only the Center Conductor or the Outer Conductor will effect the Notch Depth in addition to the Center Frequency. The variable that is being adjusted with this procedure is the length of the Center Conductor inside the Trap Filter. The gap between the Trap and the Main Line should not be changed. Moving only the Inner or the Outer Conductors by itself will effect the Gap and the Notch depth.

To effect the Notch Depth Only, both sections will have to be moved. The Notch Depth is controlled by the Gap between the Center Conductor and the Trap Section. This Gap also has an effect on the Center Frequency. To Deepen the Notch, Shorten the Outer Conductor and pull the Center Conductor Out until the Notch is back in the same place. Move the Sections in the opposite direction to make a Shallow Notch.

After tuning has been completed, tighten the Clamp and the Allen Screws which hold the Conductors. Use the Fine Tuning Bolts to bring the Frequency In. The Final Tuning Adjustments should be completed with the Transmitter driving the Output Trap Filter for at least one hour to allow for warm-up drift.

This completes the Alignment Procedure for the Bandpass Filter Assembly.

APPENDIX A
SYSTEM SPECIFICATIONS

Low Power Transmitter 10W-6kW



Designed to provide broadcasters with a product that will meet their needs like no other solution on the market, this new low to medium power transmitter line uses the latest LDMOS devices for broadband operation across the entire UHF band. This allows users to minimize spare parts stock, which is especially important to group owners and networks, and also enables simple and inexpensive channel changes.

The very compact and completely modular design uses a chassis/backplane configuration with parallel amplifier and power supply modules that can be removed and replaced while the transmitter is on the air. Additionally, the Innovator LX series was designed to be field upgradable to digital operation.

Configurations are available in power levels from 10 watts to 6 kilowatts analog and up to 3 kilowatts DTV, and all are manufactured in the USA by Axcera - *The RF Experts*.

Low Power Transmitter 10W - 6kW

Visual Performance

Frequency Range	470 to 806 MHz
Carrier Stability (<i>Transmitters</i>)	
Standard	±1 kHz
Optional w/PFC	±350 Hz
Frequency Translation Stability (<i>Translators</i>)	
Standard	±1 kHz
Optional w/PFC	±350 Hz
Regulation of RF Output Power	3%
Output Variation (<i>Over 1 Frame</i>)	2%
Sideband Response	
-1.25 MHz and below	-20 dB
-0.75 to -0.5 MHz	+0.5 db, -2 dB
-0.5 to +3.58 MHz	±0.5 dB
+3.58 MHz to +4.18 MHz	+0.5, -1.0 dB
Freq Response vs. Brightness	±0.5 dB
Visual Modulation Capability	1%
Differential Gain	5%
Incidental Phase Modulation	±3°
Linearity (<i>Low Frequency</i>)	5%

Visual Performance (*continued*)

Differential Phase	±3°
Signal-to-Noise Ratio	55 dB
2t K-Factor	2%
Noise Factor (<i>Translators</i>)	5 dB (<i>Max</i>)
w/Input Preamp	3 dB (<i>Max</i>)
Input Dynamic Range (<i>Translators</i>)	-60 dB to -15 dBm
w/Input Preamp	-75 dBm to -30 dBm
Env. Delay (<i>Transmitters</i>)	Per FCC Standard
Video Input (<i>Transmitters</i>)	75 ohms (Loop through)
Harmonics	-60 dB or better
Intermodulation Products	-52 dB or better
Spurious (<i>±3 MHz from channel edge</i>)	
100W and lower	-50dB or better
Greater than 100W	-60dB or better

Aural Performance

Frequency Deviation Capability (<i>Transmitters</i>)	±75 kHz
Distortion	0.5%
FM Noise	-60 dB
AM Noise	-55 dB
Aural to Visual Separation	4.5 MHz ± 100Hz
Composite Audio Input (<i>Multi-channel sound Transmitters</i>)	
Input Level	1V peak, nominal
Input Impedance	75 ohms, unbalanced
Frequency Range	
±0.1 dB response	50 Hz to 50 kHz
±0.5 dB response	30 Hz to 120 kHz
Monaural Audio Input (<i>Transmitters</i>)	
Input Level	0 to +10 dBm
Input	600 ohms, balanced
Freq Range (<i>±0.5 dB resp.</i>)	30 Hz to 15 kHz
Pre-emphasis	75µs
Subcarrier Input (<i>Transmitters</i>)	
Input Level	1V peak, nominal
Input Impedance	75 ohms, unbalanced
Freq Range (<i>±0.5 dB resp.</i>)	20 kHz to 120 kHz

General

Model Number*	LU10Ax	LU100Ax	LU250Ax	LU500Ax	LU1000Ax	LU2000Ax	LU3000Ax	LU4000Ax	LU5000Ax	LU6000Ax
Power Output (<i>Watts</i>)										
Visual (<i>Peak</i>)	10	100	250	500	1000	2000	3000	4000	5000	6000
Aural (<i>Avg.</i>)	1	10	25	50	100	200	300	400	500	600
Output Connector	N	N	7/8" EIA	7/8" EIA	7/8" EIA	7/8" EIA	3 1/8" EIA	3 1/8" EIA	3 1/8" EIA	3 1/8" EIA
Power Consumption (<i>Watts</i>)	250	675	1100	1900	3500	6700	10,250	13,500	16,700	19,900
Input Power										
Line Voltage (<i>Volts</i>)	117/230 ±10%		230 ± 10%							
Power Requirements	Single Phase, 50 or 60 Hz									
Size (<i>H x W x D</i>)	8.75"x19"x23" <i>(Chassis Only)</i>		55"x22"x34"				76"x22"x34"		76"x44"x34"	
Weight (<i>lbs.</i>)	45	45	340	360	400	550	700	1030	1180	1330
Operational Temperature Range	0 to +50°, derate 2°C/1000 ft.									
Maximum Altitude ³	8500 feet (2600m) AMSL									
Operational Humidity Range	0% to 95% non-condensing									
RF Load Impedance	50 Ω									

* For transmitters use "T" suffix, translators use "L" suffix (ex. LU100AT - 100W Transmitter)

Specifications published here are current as of the date of publication of this document. Because we are continuously improving our products, Axcera reserves the right to change specifications without prior notice. At any time, you may verify product specifications by contacting our office. Axcera views its patent portfolio as an important corporate asset and vigorously enforces its patents. Products or features contained herein may be covered by one or more U.S. or foreign patents.

APPENDIX B
SAMPLE LOG SHEET

UHF Exciter

ALC (0 to 1 V) = _____V % Aural Power (0 to 120) = _____%

% Reflected (0 to 120) = _____%

% Visual Power (0 to 120) = _____%

Date _____

Customer Name _____ Call Letters _____

Technician _____

APPENDIX C

SUBASSEMBLY DRAWINGS AND PARTS LISTS

Innovator LX UHF Translator System	1303268	
100 Watt Exciter Block Diagram.....	1302139	
System Block Diagram.....	1303374	
System Interconnect.....	1303375	
Chassis Assembly, Exciter, Innovator LX Series	1301914	
Interconnect	1303108	
Backplane Board, Innovator LX Series	1301941	
Schematic	1301995	
IF Processor Assembly	1301938	
IF Processor Board	1301977	
Schematic	1301983	
Upconverter Assembly, Analog	1301930	
Interconnect	1302060	
Front Panel LED Display Board	1303033	
Schematic	1303035	
UHF Filter.....		1007-1
Schematic	1007-3101	
UHF Generator Board	1585-1265	
Schematic	1585-3265	
L.O./Upconverter Assembly.....	1303039	
Contains a L.O./Upconverter Board (1302132).		
L.O./Upconverter Board	1302132	
Schematic	1302134	
Control/Power Supply Assembly	1301936	
Interconnect	1302062	
Control Board.....	1302021	
Schematic	1302023	
Power Protection Board.....	1302837	
Schematic	1302839	
Switch Board	1527-1406	
Schematic	1527-3406	
Power Amplifier Assembly, Exciter, 100 Watt Transmitter	1301923	
Interconnect	1302061	
Coupler Board Assembly	1301949	
Schematic	1303152	
Amplifier Control Board.....	1301962	
Schematic	1301964	
1 Watt Module Assembly.....	1302891	
Contains a 1 Watt UHF Amplifier Board (1302761).		

1 Watt UHF Amplifier Board.....	1302761
Schematic	1302762
TFS 40W UHF Module, Tested.....	1206693
Made from a TFS 40W UHF Module, Stork (51-5379-308-00).	
TFS 40W UHF Module, Stork	51-5379-308-00
Schematic	51-5379-308-00 WSP
RF Module Pallet, Philips.....	1300116
Made from a RF Module Pallet w/o Transistors (1152336).	
RF Module Pallet w/o Transistors	1152336
Schematic	51-5379-309-00 WSP
UHF/VHF Receiver Tray	1265-1100
Block Diagram	1265-3100
Interconnect	1265-8100
VHF Channel Filter, Low Band	
Schematic	1034-3202
VHF L.O. Filter, Low Band	
Schematic	1034-3211
±12V(3A) Power Supply Board	
Schematic	1092-3206
Channel Oscillator Board, Dual Oven	
Schematic	1145-3201
Dual Stage Amplifier	
Schematic	1227-3501
Downconverter Amplifier Board	
Schematic	1227-3502
IF Filter/ALC Board	
Schematic	1227-3504
x2 Multiplier Board	
Schematic	1227-3524