INSTRUCTION MANUAL

**Innovator,
LX Series
UHF Analog
Driver/Transmitter/Translator**

AXCERA, LLC

103 FREEDOM DRIVE P.O. BOX 525 LAWRENCE, PA 15055-0525 USA
(724) 873-8100 • FAX (724) 873-8105
www.axcera.com • info@axcera.com



TABLE OF CONTENTS

CHAPTER 1 INTRODUCTION	
SECTION	PAGE
1.1 Manual Overview	1-1
1.2 Assembly Designators	1-1
1.3 Safety.....	1-2
1.4 Contact Information.....	1-2
1.5 Material Return Procedure	1-2
1.6 Limited One Year Warranty for Axcera Products.....	1-3
CHAPTER 2 SYSTEM DESCRIPTION, MAINTENANCE & REMOTE CONTROL CONNECTIONS	
System Overview	2-1
2.0 (Optional) Exciter Switcher Tray.....	2-2
2.1 Exciter/Amplifier Chassis Assembly	2-2
2.1.1 Receiver Module (not used in a transmitter system)	2-2
2.1.2 Modulator Module (may not be used in a translator system)	2-4
2.1.3 IF Processor Module	2-5
2.1.4 VHF/UHF Upconverter Module	2-7
2.1.5 Control & Monitoring/Power Supply Module	2-9
2.1.6 Exciter PA Module used in 10-100W Xmitters. or Drvrs above 2kW ..	2-10
2.1.6.1 Driver Amplifier Module, used with 1kW or 2kW transmitters ..	2-12
2.1.7 RF Output Assemblies.....	2-14
2.2 Control and Status	2-14
2.2.1 Front Panel LCD Display Screen.....	2-14
2.3 System Operation	2-14
2.3.1 Principles of Operation.....	2-14
2.4 Maintenance	2-17
2.5 Customer Remote Connections	2-17
CHAPTER 3 SITE CONSIDERATIONS, INSTALLATION AND SETUP PROCEDURES	
3.1 Site Considerations.....	3-1
3.2 Unpacking the Chassis w/Modules, bandpass and trap filters.....	3-5
3.3 Installing the Chassis w/Modules and filters.....	3-5
3.4 AC Input	3-6
3.5 Setup and Operation.....	3-7
3.5.1 Input Connections	3-7
3.5.2 Initial Turn On	3-9
3.5.2.1 (Optional) Receiver Module LEDs on Front Panel.....	3-9
3.5.2.2 Modulator Module LEDs on Front Panel	3-9
3.5.2.3 IF Processor Module LEDs on Front Panel.....	3-10
3.5.2.4 VHF/UHF Upconverter Module LEDs on Front Panel	3-10
3.5.2.5 Controller Module LEDs on Front Panel	3-10
3.5.2.6 Power Amplifier or Driver Module LEDs on Front Panel.....	3-10
3.5.3 Front Panel Screens for the (Optional) Exciter Switcher Assembly	3-10
3.5.4 Front Panel Screens for the Exciter/Amplifier Chassis Assembly	3-13
3.5.5 Operation Procedure	3-22
CHAPTER 4 CIRCUIT DESCRIPTIONS	
4.0 (Optional) Exciter Switcher Tray (Used with dual exciter system)	4-1

TABLE OF CONTENTS - (Continued)

SECTION	PAGE
4.0.1 Exciter Switcher Control Board	4-1
4.1 (Optional) Receiver Module (not used in a transmitter system)	4-1
4.1.1 IF ALC Board	4-1
4.1.2 UHF or VHF Mixer/PLL Board	4-2
4.1.3 UHF, VHF LB or VHF HB Preamplifier Board.....	4-2
4.2 Modulator Module (may not be used in a translator system)	4-3
4.2.1 Analog Modulator Board	4-3
4.2.1.1 Mono, Balanced Audio Input	4-3
4.2.1.2 Stereo, Composite Audio Input	4-3
4.2.1.3 SAP/PRO, Subcarrier Audio Input	4-4
4.2.1.4 Audio Modulation of the 3.4 MHz VCO	4-4
4.2.1.5 Phase Lock Loop (PLL) Circuit	4-4
4.2.1.6 Main Video Signal Path (Part 1 of 2).....	4-5
4.2.1.7 Delay Equalizer Circuits.....	4-5
4.2.1.8 Sync Tip Clamp Circuit	4-6
4.2.1.9 Main Video Signal Path (Part 2 of 2).....	4-6
4.2.1.10 45.75 MHz Oven Oscillator Circuit	4-6
4.2.1.11 Visual Modulator Circuit	4-7
4.2.1.12 Aural Modulator Circuit	4-7
4.2.1.13 Combining the 45.75 MHz & 41.25 MHz IF Signals	4-8
4.2.1.14 Voltage Requirements	4-8
4.3 IF Processor Module.....	4-8
4.3.1 IF Processor Board.....	4-8
4.3.1.1 Modulator Selected.....	4-9
4.3.1.2 External Modulated IF Selected.....	4-9
4.3.1.3 Main IF Signal Path (Part 1 of 3)	4-9
4.3.1.4 Input Level Detector Circuit.....	4-9
4.3.1.5 Pin-Diode Attenuator Circuit	4-10
4.3.1.6 Main IF Signal Path (Part 2 of 3)	4-11
4.3.1.7 Amplitude and Phase Pre-Correction Circuits.....	4-11
4.3.1.8 Main IF Signal Path (Part 3 of 3)	4-12
4.3.1.9 ALC Circuit.....	4-13
4.3.1.10 Fault Command	4-13
4.3.1.11 ± 12 VDC needed to operate Board.....	4-14
4.4 VHF/UHF Upconverter Module	4-14
4.4.1 Downconverter Board	4-14
4.4.2 L-Band PLL Board	4-14
4.4.3 First Conversion Board.....	4-15
4.4.4 Upconverter Control Board	4-15
4.5 Control Monitoring/Power Supply Module	4-16
4.5.1 Power Protection Board.....	4-16
4.5.1.1 +12 VDC Circuits	4-16
4.5.1.2 -12 VDC Circuits	4-17
4.5.2 Control Board	4-17
4.5.2.1 Schematic Page 1.....	4-17
4.5.2.2 Schematic Page 2.....	4-18
4.5.2.3 Schematic Page 3.....	4-18
4.5.2.4 Schematic Page 4.....	4-18
4.5.2.5 Schematic Page 5.....	4-19
4.5.3 Switch Board	4-19
4.5.4 Switching Power Supply Assembly	4-19

TABLE OF CONTENTS - (Continued)

SECTION	PAGE
4.6 Exciter PA Module used in 10-100Watt Xmitters. or Drivers above 2kW	4-20
4.6.1 1 Watt Amplifier Module Assembly	4-20
4.6.2 1 Watt UHF Amplifier Board	4-20
4.6.3 40 Watt UHF Amplifier Assembly	4-21
4.6.4 UHF Module Assembly, RF Module Pallet	4-22
4.6.5 Coupler Board Assembly	4-22
4.6.6 Amplifier Control Board	4-22
4.6.6.1 Schematic Page 1	4-22
4.6.6.2 Schematic Page 2	4-23
4.6.6.3 Current Monitoring Sections of the Board	4-23
4.6.6.4 Schematic Page 3 Aural, Visual. Aural Power Detectors	4-24
4.6.7 Bandpass and Trap Filters	4-24
OR 4.7 Driver Amplifier Module Assembly used in 1kW or 2kW transmitters	4-24
4.7.1 1-Watt Amplifier Module Assembly	4-25
4.7.2 1-Watt UHF Amplifier Board	4-25
4.7.3 40 Watt UHF Amplifier Assembly	4-26
OR 4.7.3.1 250 Watt UHF Amplifier Assembly	4-26
4.7.4 Coupler Board Assembly	4-26
4.7.5 Amplifier Control Board	4-27
4.7.5.1 Schematic Page 1	4-27
4.7.5.2 Schematic Page 2	4-28
4.7.5.3 Current Monitoring Sections of the Board	4-28
4.7.5.4 Schematic Page 3 Aural, Visual. Aural Power Detectors	4-28

CHAPTER 5 DETAILED ALIGNMENT PROCEDURES

5.1 Module Replacement	5-1
5.1.1 Initial Test Setup	5-1
5.2 LX Series Exciter/Amplifier Chassis Assembly	5-2
5.2.1 (Optional) Receiver Module Assembly	5-2
5.2.2 Modulator Module Assembly	5-2
5.2.3 IF Processor Module Assembly	5-3
5.2.4 VHF/UHF Upconverter Assembly	5-4
5.2.5 Setting up the Drive Level of the Transmitter Procedure	5-4
5.2.6 Changing the Transmitter Channel Procedure	5-4
5.2.7 Linearity Correction Adjustment	5-9
5.2.8 Frequency Response Delay Equalization Adjustment	5-10
5.2.9 Calibration of Output Power & Reflected Power of Transmitter	5-10
5.3 Bandpass Filter Assembly	5-11
5.4 UHF Trap Filter Assembly	5-11
5.4.1 Effects of Tuning the Output Trap Filter	5-13

APPENDICES

APPENDIX A LX SERIES SPECIFICATIONS

APPENDIX B LX SERIES DRAWINGS AND PARTS LISTS

APPENDIX C TRANSMITTER LOG SHEET

FIGURE	LIST OF FIGURES	PAGE
1-1	Brady Marker Identification Drawing	1-1
2-1	Exciter/Driver Chassis Assembly Front View	2-1
2-2	Exciter/Driver Chassis Assembly Rear View	2-18
3-1	1 kW Minimum Ventilation Configuration	3-4
3-2	Front and Rear View Reconnection Drawings	3-5
3-3	Ac Input Box Assembly	3-7
3-4	Rear View of LX Series Analog Transmitter	3-8
4-1	40 Watt UHF Amplifier Module	4-21
4-2	250 Watt UHF Amplifier Module	4-21
4-3	40 Watt UHF Amplifier Module	4-25
4-2	250 Watt UHF Amplifier Module	4-26
5-1	Typical Red Field Spectrum.....	5-9
5-2	Bandpass Filter	5-12

LIST OF TABLES

TABLE		PAGE
2-1	LX Series Trays and Assemblies.....	2-1
2-2	Receiver Front Panel Switch.....	2-3
2-3	Receiver Front Panel Status Indicators.....	2-3
2-4	Receiver Front Panel Control Adjustments.....	2-3
2-5	Receiver Front Panel Samples.....	2-3
2-6	Modulator Front Panel Switch.....	2-4
2-7	Modulator Front Panel Status Indicators.....	2-4
2-8	Modulator Front Panel Control Adjustments.....	2-5
2-9	Modulator Front Panel Sample.....	2-5
2-10	IF Processor Front Panel Switch.....	2-6
2-11	IF Processor Front Panel Status Indicators.....	2-6
2-12	IF Processor Front Panel Control Adjustments.....	2-7
2-13	IF Processor Front Panel Sample.....	2-7
2-14	VHF/UHF Upconverter Front Panel Switch.....	2-8
2-15	VHF/UHF Upconverter Front Panel Status Indicators.....	2-8
2-16	VHF/UHF Upconverter Front Panel Control Adjustments.....	2-8
2-17	VHF/UHF Upconverter Front Panel Samples.....	2-8
2-18	Controller/Power Supply Front Panel Display.....	2-9
2-19	Controller/Power Supply Front Panel Status Indicators.....	2-9
2-20	Controller/Power Supply Front Panel Control Adjustments.....	2-9
2-21	Power Amplifier Front Panel Status Indicators.....	2-11
2-22	Power Amplifier Front Panel Control Adjustments.....	2-11
2-23	Power Amplifier Front Panel Sample.....	2-11
2-24	Driver Amplifier Front Panel Status Indicators.....	2-13
2-25	Driver Amplifier Front Panel Control Adjustments.....	2-13
2-26	Driver Amplifier Front Panel Sample.....	2-13
2-27	UHF Television Frequencies.....	2-16
2-28	LX Series Chassis Customer Remote Connections.....	2-18
2-29	(Optional) Dual Exciter Customer Remote Connections.....	2-20
3-1	LX Series Transmitters AC Input and Current Requirements.....	3-1
3-2	LX Series Transmitters AC Input and Current Requirements.....	3-6
3-3	Rear Chassis Connections for LX Series Analog Transmitters.....	3-8
	(Optional) Exciter Switcher Tray Menu Screens.....	3-11
3-4	Exciter Switcher Menu 01 Splash Screen #1.....	3-11
3-5	Menu 02 Splash Screen #2.....	3-11
3-6	Menu 03 Exciter Switcher Control Screen, Automatic Operation.....	3-11
3-7	Menu 04 Exciter Switcher Control Screen, Manual Operation.....	3-11
3-8	Menu 05 Exciter Switcher Control Screen, Amps On Line.....	3-11
3-9	Menu 06 Exciter Switcher Control Screen, Cancel Auto Back up.....	3-12
3-10	Menu 07 Exciter Switcher Control Screen, B Back up to A.....	3-12
3-11	Menu 08 Exciter Switcher Control Screen, back up Changeover.....	3-12
3-12	Menu 09 Exciter Switcher Control Screen, Ext Amp Status.....	3-12
3-13	Menu 10 Exciter Switcher Control Screen, Ext Amp Status.....	3-12
	LX System Controller Menu Screens.....	3-13
3-14	Menu 01 Splash Screen #1.....	3-13
3-15	Menu 02 Splash Screen #2.....	3-13
3-16	Menu 10 Main Screen.....	3-13
3-17	Menu 11 Error List Access Screen.....	3-14
3-18	Menu 12 Transmitter Device Data Access Screen.....	3-14
3-19	Menu 13 Transmitter Configuration Access Screen.....	3-14

LIST OF TABLES – (Continued)

TABLE		PAGE
3-20	Menu 20 Error List Display Screen.....	3-14
3-21	Menu 30 Transmitter Device Details Screen	3-15
3-22	Menu 30-1 System Details Screens	3-15
3-23	Transmitter Device Parameters Detail Screens	3-15
3-24	Menu 40 Authorized Personnel Screen	3-16
3-25	Menu 40-1 Transmitter Set Up: Power Raise/Lower Screen.....	3-17
3-26	Menu 40-2 Transmitter Set Up: Model Select Screen	3-17
3-27	Menu 40-3 Transmitter Set Up: Receiver Channel Configuration	3-18
3-28	Menu 40-4 Transmitter Set Up: Upconverter Channel Select Screen.....	3-18
3-29	Menu 40-5 Transmitter Set Up: Serial Address Screen.....	3-18
3-30	Menu 40-6 Transmitter Set Up: Station ID Screen.....	3-18
3-31	Menu 40-7 Transmitter Set Up: System Visual Power Cal. Screen.....	3-19
3-32	Menu 40-8 Transmitter Set Up: System Aural Power Cal. Screen.....	3-19
3-33	Menu 40-9 Transmitter Set Up: System Rfltd. Power Cal. Screen	3-19
3-34	Menu 40-10 Transmitter Set Up: Modulated Output Cal. Screen.....	3-19
3-35	Menu 40-11 Transmitter Set Up: Aural Deviation Screen	3-20
3-36	Menu 40-12 Transmitter Set Up: Fwrd Pwr Fault Threshold Screen	3-20
3-37	Menu 40-13 Transmitter Set Up: Refl Power Fault Threshold Screen ..	3-20
3-38	Menu 40-14 Transmitter Set Up: DLC Control Screen.....	3-20
3-39	Menu 40-15 Transmitter Set Up: Auto Standby Control Screen.....	3-21
3-40	Menu 40-16 Transmitter Set Up: Receiver ALC Fault Set Up Screen ...	3-21
3-41	Menu 40-17 Transmitter Set Up: Inner Loop Gain Control Screen.....	3-21
3-42	Menu 40-18 Transmitter Set Up: Optional System Control Screen	3-21
3-43	Menu 40-19 Transmitter Set Up: Remote Command Control Screen...	3-22
5-1	Typical Bandpass Values	5-11

Chapter 1 Introduction

1.1 Manual Overview

This manual explains the installation, setup, alignment, and maintenance procedures for the Innovator LX Series UHF analog modular driver/transmitter/translator. It is important that you read all of the instructions, especially the safety information in this chapter, before you begin to install or operate the unit.

This instruction manual is divided into five chapters and supporting appendices. **Chapter 1**, Introduction, contains information on the assembly numbering system used in the manual, safety, contact information, return procedures, and warranties. **Chapter 2**, System Description, Maintenance & Remote Control Connections, describes the driver/transmitter/translator and includes discussions on system control and status indicators, maintenance, and remote control connections. **Chapter 3**, Site Considerations, Installation and Setup Procedures, explains how to unpack, install, setup, and operate the driver/transmitter/translator. **Chapter 4**, Circuit Descriptions, contains circuit level descriptions for boards and board level components in the driver/transmitter/translator. **Chapter 5**, Detailed Alignment Procedures, provides information on adjusting the system assemblies for optimal operation. **Appendix A** contains system specifications. **Appendix B** contains drawings and parts lists. **Appendix C** contains a transmitter log sheet.

1.2 Assembly Designators

Axcera has assigned assembly numbers,

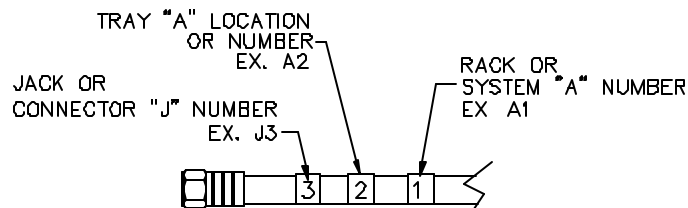

Figure 1-1 Brady Marker Identification Drawing

Ax designations such as A1, where x=1,2,3...etc, to all assemblies, modules, and boards in the system. These designations are referenced in the text of this manual and shown on the block diagrams and interconnect drawings provided in the appendices. The Block Diagrams, Interconnects, Schematics, Assembly Drawings and Parts Lists are arranged in increasing numerical order in the appendices. Section titles in the text for assembly or module descriptions or alignment procedures contain the associated part number(s) and the relevant appendix that contains the drawings for that item.

The cables that connect between the boards within a tray or assembly and that connect between the trays, racks and cabinets are labeled using Brady markers.

Figure 1-1 is an example of a Brady marked cable. There may be as few as two or as many as four Markers on any one cable. These Brady markers are read starting furthest from the connector. If there are four Brady Markers, this marker is the transmitter number such as transmitter 1 or transmitter 2. The next or the furthest Brady Marker is the rack or cabinet number on an interconnect cable or the board number within a tray. The next number on an interconnect cable is the Tray location or number. The Brady marker closest to the connector is the jack or connector number on an interconnect cable or the jack or connector number on the board within a tray.

1.3 Safety

The UHF transmitter systems manufactured by Axcera are designed to be easy to use and repair while providing protection from electrical and mechanical hazards. Please review the following warnings and familiarize yourself with the operation and servicing procedures before working on the transmitter system.

Read All safety Instructions – All of the safety instructions should be read and understood before operating this equipment.

Retain Manuals – The manuals for the transmitter should be retained at the transmitter site for future reference. Axcera provides two sets of manuals for this purpose; one set can be left at the office while one set can be kept at the site.

Heed all Notes, Warnings, and Cautions – All of the notes, warnings, and cautions listed in this safety section and throughout the manual must be followed.

Follow Operating Instructions – All of the operating and use instructions for the transmitter should be followed.

Cleaning – Unplug or otherwise disconnect all power from the equipment before cleaning. Do not use liquid or aerosol cleaners. Use a damp cloth for cleaning.

Ventilation – Openings in the cabinet and module front panels are provided for ventilation. To ensure the reliable operation of the driver/transmitter, and to protect the unit from overheating, these openings must not be blocked.

Servicing – Do not attempt to service this product yourself until becoming familiar with the equipment. If in doubt, refer all servicing questions to qualified Axcera service personnel.

Replacement Parts – When replacement parts are used, be sure that the parts have the same functional and performance characteristics as the original part. Unauthorized substitutions may result in fire, electric shock, or other hazards. Please contact the Axcera Technical Service Department if you have any questions regarding service or replacement parts.

1.4 Contact Information

The Axcera Field Service Department can be contacted by phone at **(724) 873-8100** or by fax at **(724) 873-8105**.

Before calling Axcera, please be prepared to supply the Axcera technician with answers to the following questions. This will save time and help ensure the most direct resolution to the problem.

1. What are the Customers' Name and call letters?
2. What are the model number and type of transmitter?
3. Is the transmitter digital or analog?
4. How long has the transmitter been on the air? (Approximately when was the transmitter installed.)
5. What are the symptoms being exhibited by the transmitter? Include the current control/power supply LCD readings and the status of LEDs on the front panels of the modules. If possible, include the control/power supply LCD readings before the problem occurred.

1.5 Return Material Procedure

To insure the efficient handling of equipment or components that have been returned for repair, Axcera requests that each returned item be accompanied by a Return Material Authorization Number (RMA#).

The RMA# can be obtained from any Axcera Field Service Engineer by contacting the Axcera Field Service Department at (724) 873-8100 or by fax at (724) 873-8105. This procedure applies to all items sent to the Field Service Department regardless of whether the item was originally manufactured by Axcera.

When equipment is sent to the field on loan, an RMA# is included with the unit. The RMA# is intended to be used when the unit is returned to Axcera. In addition, all shipping material should be retained for the return of the unit to Axcera.

Replacement assemblies are also sent with an RMA# to allow for the proper routing of the exchanged hardware. Failure to close out this type of RMA# will normally result in the customer being invoiced for the value of the loaner item or the exchanged assembly.

When shipping an item to Axcera, please include the RMA# on the packing list and on the shipping container. The packing slip should also include contact information and a brief description of why the unit is being returned.

Please forward all RMA items to:

AXCERA, LLC
103 Freedom Drive
P.O. Box 525
Lawrence, PA 15055-0525 USA

For more information concerning this procedure, call the Axcera Field Service Department @ (724) 873-8100. Axcera can also be contacted through e-mail at info@axcera.com and on the Web at www.axcera.com.

1.6 Limited One Year Warranty for Axcera Products

Axcera warrants each new product that it has manufactured and sold against

defects in material and workmanship under normal use and service for a period of one (1) year from the date of shipment from Axcera's plant, when operated in accordance with Axcera's operating instructions. This warranty shall not apply to tubes, fuses, batteries, bulbs or LEDs.

Warranties are valid only when and if (a) Axcera receives prompt written notice of breach within the period of warranty, (b) the defective product is properly packed and returned by the buyer (transportation and insurance prepaid), and (c) Axcera determines, in its sole judgment, that the product is defective and not subject to any misuse, neglect, improper installation, negligence, accident, or (unless authorized in writing by Axcera) repair or alteration. Axcera's exclusive liability for any personal and/or property damage (including direct, consequential, or incidental) caused by the breach of any or all warranties, shall be limited to the following: (a) repairing or replacing (in Axcera's sole discretion) any defective parts free of charge (F.O.B. Axcera's plant) and/or (b) crediting (in Axcera's sole discretion) all or a portion of the purchase price to the buyer.

Equipment furnished by Axcera, but not bearing its trade name, shall bear no warranties other than the special hours-of-use or other warranties extended by or enforceable against the manufacturer at the time of delivery to the buyer.

NO WARRANTIES, WHETHER STATUTORY, EXPRESSED, OR IMPLIED, AND NO WARRANTIES OF MERCHANTABILITY, FITNESS FOR ANY PARTICULAR PURPOSE, OR FREEDOM FROM INFRINGEMENT, OR THE LIKE, OTHER THAN AS SPECIFIED IN PATENT LIABILITY ARTICLES, AND IN THIS ARTICLE, SHALL APPLY TO THE EQUIPMENT FURNISHED HEREUNDER.

 **WARNING!!!****◀ HIGH VOLTAGE ▶**

DO NOT ATTEMPT TO REPAIR OR TROUBLESHOOT THIS EQUIPMENT UNLESS YOU ARE FAMILIAR WITH ITS OPERATION AND EXPERIENCED IN SERVICING HIGH VOLTAGE EQUIPMENT. LETHAL VOLTAGES ARE PRESENT WHEN POWER IS APPLIED TO THIS SYSTEM. IF POSSIBLE, TURN OFF POWER BEFORE MAKING ADJUSTMENTS TO THE SYSTEM.

★ RADIO FREQUENCY RADIATION HAZARD ★

MICROWAVE, RF AMPLIFIERS AND TUBES GENERATE HAZARDOUS RF RADIATION THAT CAN CAUSE SEVERE INJURY INCLUDING CATARACTS, WHICH CAN RESULT IN BLINDNESS. SOME CARDIAC PACEMAKERS MAY BE AFFECTED BY THE RF ENERGY EMITTED BY RF AND MICROWAVE AMPLIFIERS. NEVER OPERATE THE TRANSMITTER SYSTEM WITHOUT A PROPERLY MATCHED RF ENERGY ABSORBING LOAD ATTACHED. KEEP PERSONNEL AWAY FROM OPEN WAVEGUIDES AND ANTENNAS. NEVER LOOK INTO AN OPEN WAVEGUIDE OR ANTENNA. MONITOR ALL PARTS OF THE RF SYSTEM FOR RADIATION LEAKAGE AT REGULAR INTERVALS.

EMERGENCY FIRST AID INSTRUCTIONS

Personnel engaged in the installation, operation, or maintenance of this equipment are urged to become familiar with the following rules both in theory and practice. It is the duty of all operating personnel to be prepared to give adequate Emergency First Aid and thereby prevent avoidable loss of life.



RESCUE BREATHING

1. Find out if the person is breathing.

You must find out if the person has stopped breathing. If you think he is not breathing, place him flat on his back. Put your ear close to his mouth and look at his chest. If he is breathing you can feel the air on your cheek. You can see his chest move up and down. If you do not feel the air or see the chest move, he is not breathing.

2. If he is not breathing, open the airway by tilting his head backwards.

Lift up his neck with one hand and push down on his forehead with the other. This opens the airway. Sometimes doing this will let the person breathe again by himself.

3. If he is still not breathing, begin rescue breathing.

- Keep his head tilted backward. Pinch nose shut.
- Put your mouth tightly over his mouth.
- Blow into his mouth once every five seconds
- DO NOT STOP** rescue breathing until help arrives.

LOOSEN CLOTHING - KEEP WARM

Do this when the victim is breathing by himself or help is available. Keep him as quiet as possible and from becoming chilled. Otherwise treat him for shock.

BURNS

SKIN REDDENED: Apply ice cold water to burned area to prevent burn from going deeper into skin tissue. Cover area with a clean sheet or cloth to keep away air. Consult a physician.

SKIN BLISTERED OR FLESH CHARRED: Apply ice cold water to burned area to prevent burn from going deeper into skin tissue.

Cover area with clean sheet or cloth to keep away air. Treat victim for shock and take to hospital.

EXTENSIVE BURN - SKIN BROKEN: Cover area with clean sheet or cloth to keep away air. Treat victim for shock and take to hospital.

Note: Because of possible FCC assigned offset, check for the assigned Carrier Frequency as written on License.

UHF Frequency Assignments				
Channel Number	Bandwidth (MHz)	Video (MHz)	Color (MHz)	Audio (MHz)
14	470-476	471.25	474.83	475.75
15	476-482	477.25	480.83	481.75
16	482-488	483.25	486.83	487.75
17	488-494	489.25	492.83	493.75
18	494-500	495.25	498.83	499.75
19	500-506	501.25	504.83	505.75
20	506-512	507.25	510.83	511.75
21	512-518	513.25	516.83	517.75
22	518-524	519.25	522.83	523.75
23	524-530	525.25	528.83	529.75
24	530-536	531.25	534.83	535.75
25	536-542	537.25	540.83	541.75
26	542-548	543.25	546.83	547.75
27	548-554	549.25	552.83	553.75
28	554-560	555.25	558.83	559.75
29	560-566	561.25	564.83	565.75
30	566-572	567.25	570.83	571.75
31	572-578	573.25	576.83	577.75
32	578-584	579.25	582.83	583.75
33	584-590	585.25	588.83	589.75
34	590-596	591.25	594.83	595.75
35	596-602	597.25	600.83	601.75
36	602-608	603.25	606.83	607.75
37	608-614	609.25	612.83	613.75
38	614-620	615.25	618.83	619.75
39	620-626	621.25	624.83	625.75
40	626-632	627.25	630.83	631.75
41	632-638	633.25	636.83	637.75
42	638-644	639.25	642.83	643.75
43	644-650	645.25	648.83	649.75

Note: Because of possible FCC assigned offset, check for the assigned Carrier Frequency as written on License.

UHF Frequency Assignments				
Channel Number	Bandwidth (MHz)	Video (MHz)	Color (MHz)	Audio (MHz)
44	650-656	651.25	654.83	655.75
45	656-662	657.25	660.83	661.75
46	662-668	663.25	666.83	667.75
47	668-674	669.25	672.83	673.75
48	674-680	675.25	678.83	679.75
49	680-686	681.25	684.83	685.75
50	686-692	687.25	690.83	691.75
51	692-698	693.25	696.83	697.75
52	698-704	699.25	702.83	703.75
53	704-710	705.25	708.83	709.75
54	710-716	711.25	714.83	715.75
55	716-722	717.25	720.83	721.75
56	722-728	723.25	726.83	727.75
57	728-734	729.25	732.83	733.75
58	734-740	735.25	738.83	739.75
59	740-746	741.25	744.83	745.75
60	746-752	747.25	750.83	751.75
61	752-758	753.25	756.83	757.75
62	758-764	759.25	762.83	763.75
63	764-770	765.25	768.83	769.75
64	770-776	771.25	774.83	775.75
65	776-782	777.25	780.83	781.75
66	782-788	783.25	786.83	787.75
67	788-794	789.25	792.83	793.75
68	794-800	795.25	798.83	799.75
69	800-806	801.25	804.83	805.75
70	806-812	807.25	810.83	811.75

dBm, dBw, dBmV, dBμV, & VOLTAGE EXPRESSED IN WATTS

50 Ohm System

WATTS	PREFIX	dBm	dBw	dBmV	dBμV	VOLTAGE
1,000,000,000,000	1 TERAWATT	+150	+120			
100,000,000,000	100 GIGAWATTS	+140	+110			
10,000,000,000	10 GIGAWATTS	+130	+100			
1,000,000,000	1 GIGAWATT	+120	+ 99			
100,000,000	100 MEGAWATTS	+110	+ 80			
10,000,000	10 MEGAWATTS	+100	+ 70			
1,000,000	1 MEGAWATT	+ 90	+ 60			
100,000	100 KILOWATTS	+ 80	+ 50			
10,000	10 KILOWATTS	+ 70	+ 40			
1,000	1 KILOWATT	+ 60	+ 30			
100	1 HECTROWATT	+ 50	+ 20			
50		+ 47	+ 17			
20		+ 43	+ 13			
10	1 DECAWATT	+ 40	+ 10			
1	1 WATT	+ 30	0	+ 77	+137	7.07V
0.1	1 DECIWATT	+ 20	- 10	+ 67	+127	2.24V
0.01	1 CENTIWATT	+ 10	- 20	+ 57	+117	0.707V
0.001	1 MILLIWATT	0	- 30	+ 47	+107	224mV
0.0001	100 MICROWATTS	- 10	- 40			
0.00001	10 MICROWATTS	- 20	- 50			
0.000001	1 MICROWATT	- 30	- 60			
0.0000001	100 NANOWATTS	- 40	- 70			
0.00000001	10 NANOWATTS	- 50	- 80			
0.000000001	1 NANOWATT	- 60	- 90			
0.0000000001	100 PICOWATTS	- 70	-100			
0.00000000001	10 PICOWATTS	- 80	-110			
0.000000000001	1 PICOWATT	- 90	-120			

TEMPERATURE CONVERSION

$$^{\circ}\text{F} = 32 + [(9/5) ^{\circ}\text{C}]$$

$$^{\circ}\text{C} = [(5/9) (^{\circ}\text{F} - 32)]$$

USEFUL CONVERSION FACTORS

TO CONVERT FROM	TO	MULTIPLY BY
mile (US statute)	kilometer (km)	1.609347
inch (in)	millimeter (mm)	25.4
inch (in)	centimeter (cm)	2.54
inch (in)	meter (m)	0.0254
foot (ft)	meter (m)	0.3048
yard (yd)	meter (m)	0.9144
mile per hour (mph)	kilometer per hour(km/hr)	1.60934
mile per hour (mph)	meter per second (m/s)	0.44704
pound (lb)	kilogram (kg)	0.4535924
gallon (gal)	liter	3.7854118
U.S. liquid (One U.S. gallon equals 0.8327 Canadian gallon)		
fluid ounce (fl oz)	milliliters (ml)	29.57353
British Thermal Unit	watt (W)	0.2930711
horsepower (hp)	watt (W)	per hour (Btu/hr) 746

NOMENCLATURE OF FREQUENCY BANDS

FREQUENCY RANGE	DESIGNATION
3 to 30 kHz	VLF - Very Low Frequency
30 to 300 kHz	LF - Low Frequency
300 to 3000 kHz	MF - Medium Frequency
3 to 30 MHz	HF - High Frequency
30 to 300 MHz	VHF - Very High Frequency
300 to 3000 MHz	UHF - Ultrahigh Frequency
3 to 30 GHz	SHF - Superhigh Frequency
30 to 300 GHz	EHF - Extremely High Frequency

LETTER DESIGNATIONS FOR UPPER FREQUENCY BANDS

LETTER	FREQ. BAND
L	1000 - 2000 MHz
S	2000 - 4000 MHz
C	4000 - 8000 MHz
X	8000 - 12000 MHz
Ku	12 - 18 GHz
K	18 - 27 GHz
Ka	27 - 40 GHz
V	40 - 75 GHz
W	75 - 110 GHz

ABBREVIATIONS/ACRONYMS

AC	Alternating Current	PCB	Printed circuit board
AFC	Automatic Frequency Control	QAM	Quadrature Amplitude Modulation
ALC	Automatic Level Control		
AM	Amplitude modulation		
AGC	Automatic Gain Control		
AWG	American wire gauge		
BER	Bit Error Rate		
BW	Bandwidth		
DC	Direct Current		
D/A	Digital to analog		
dB	Decibel		
dBm	Decibel referenced to 1 milliwatt		
dBmV	Decibel referenced to 1 millivolt		
dBw	Decibel referenced to 1 watt		
FEC	Forward Error Correction		
FM	Frequency modulation		
Hz	Hertz		
ICPM	Incidental Carrier Phase Modulation		
I/P	Input		
IF	Intermediate Frequency		
LED	Light emitting diode		
LSB	Lower Sideband		
MPEG	Motion Pictures Expert Group		
O/P	Output		
PLL	Phase Locked Loop		

RETURN LOSS VS. VSWR

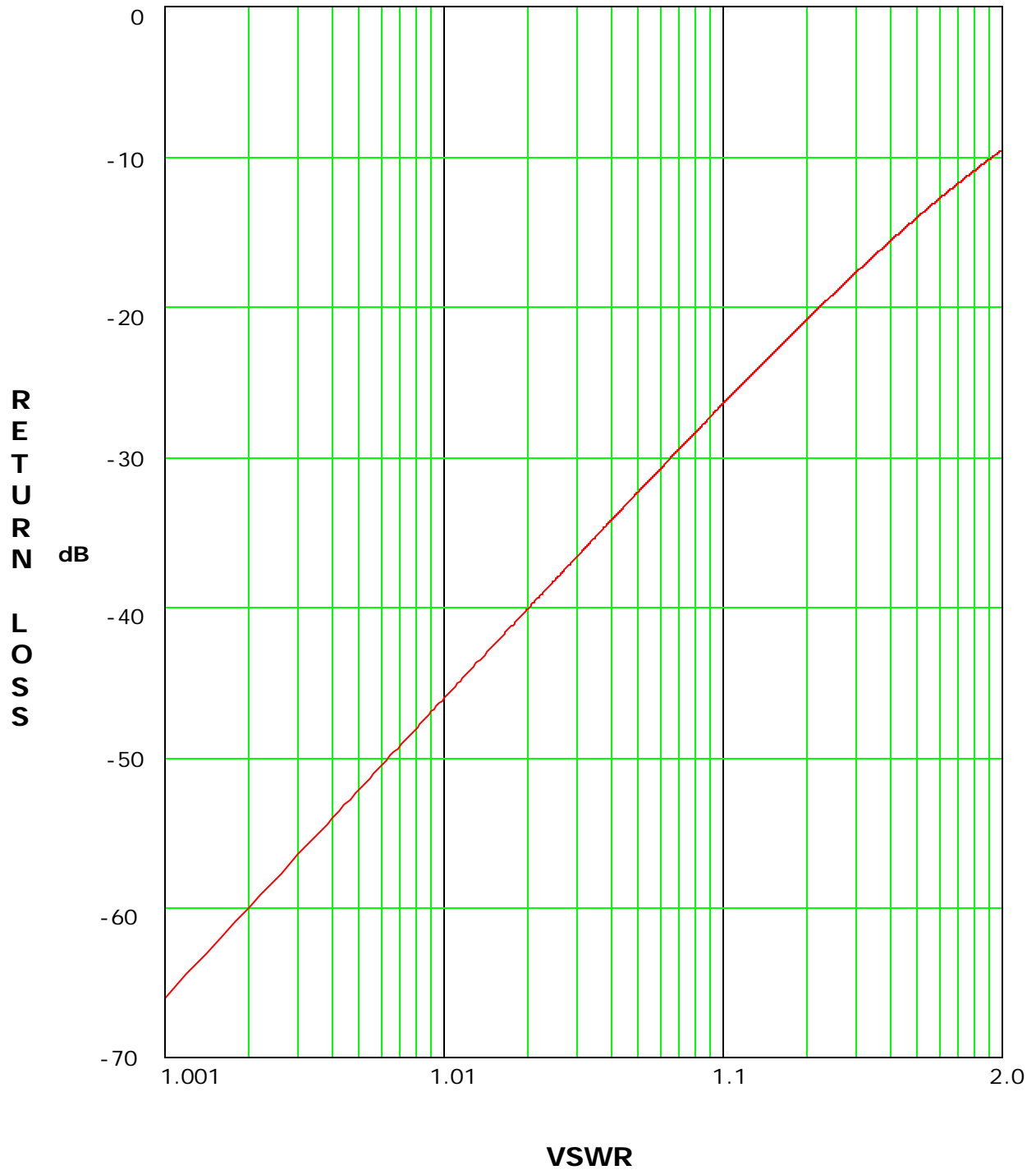

Chapter 2 System Description, Maintenance & Remote Control Connections

System Overview

The analog transmitters in the Innovator LX Series are complete 10W to 100W UHF Analog internally diplexed modular television transmitters that operate at a nominal visual output power of 10 to 100 watts peak sync and an average aural output power of 1 to 10 watts, at an A/V ratio of 10 dB, 10% sound, or .5 to 5 watts at 13 dB, 5% sound.

The LX Series can also be used as a driver for external power amplifiers. The output power of the driver is determined by the level needed to attain the full output power of the transmitter. The driver's maximum output is 7 Watts peak of sync.

The Analog LX Series driver/transmitter/translator is made up of the modules and assemblies as listed in Table 2-1.

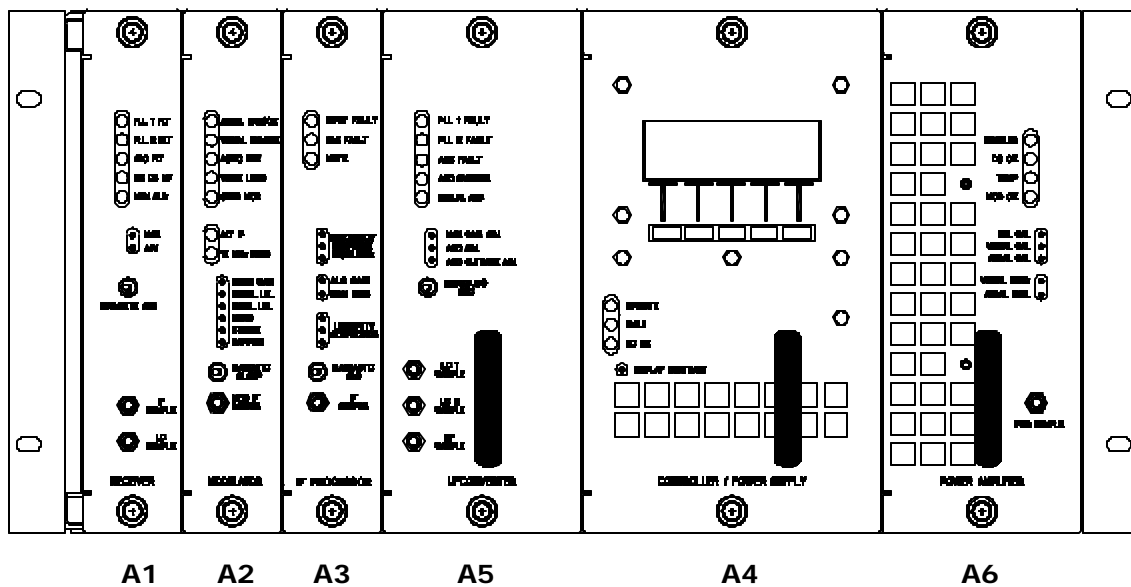

Figure 2-1: Exciter/Driver Front View

Table 2-1: LX Series Trays and Assemblies

ASSEMBLY DESIGNATOR	TRAY/ASSEMBLY NAME	PART NUMBER
	Exciter Amplifier Chassis Assembly, V2, LX Series	1304052 (110 VAC) OR 1304053 (220 VAC)
A1	Receiver Module (used in a translator system)	1304000 VHF LB, 1304001 VHF HB or 1304002 UHF
A2	Modulator Module (may not be present in translator)	1301929
A3	IF Processor Module	1301938
A4	Control/Power Supply Module	1301936 (110 VAC) OR 1303229 (220 VAC)
A5	VHF/UHF Upconverter Module	1303829
A6	Power Amplifier Module, used in 10-100 Watt transmitters & as a driver in Systems above 2kW	1303770

ASSEMBLY DESIGNATOR	TRAY/ASSEMBLY NAME	PART NUMBER
OR A6	Driver Amplifier Module, used in high power transmitters	1303771 (1kW) OR 1303874 (2kW)
A11	Backplane Board, V2, LX Series	1304047
(Optional) A14(500/1kW) or A29(5kW)	Exciter Switcher Assembly (Used in dual exciter systems)	1305727 (110 VAC) OR 1305715 (220 VAC)

2.0 (Optional) Exciter Switcher Tray, 110 VAC (1305727) or 220 VAC (1305715); Appendix B

The (optional) Single Channel Auto Switcher is part of the dual exciter system. The assembly is made up of (A1) a Single Channel Exciter Switcher Tray (1305715) with a separate (A2) coaxial transfer relay, mounted on a bracket that faces toward the rear of the cabinet, behind the Switcher Tray. The tray is factory set. The Exciter Switcher Tray is designed to monitor the selected On Air Exciter and automatically switch to the back up Exciter if the On Air Exciter should malfunction. The coaxial relay has the RF outputs from both Exciters connected to its inputs and, depending on if the energizing voltage is applied or not, the selected Exciter RF Output is connected to the external amplifiers and the RF output from the other exciter is connected to a load. The front panel has a 4 x 20 display providing a four-line readout of the operation and control of the exciter switcher. The LCD screens are detailed in Chapter 3.

2.1 Exciter Amplifier Chassis Assembly, 110 VAC (1304052) or 220 VAC (1304053); Appendix B

NOTE: In dual exciter systems there are two exciter amplifier chassis assemblies.

The chassis assembly is factory set for operation using 110 VAC or 220 VAC. All of the modules except the power amplifier module and the power supply section of the Control & Monitoring/Power Supply Module, plug directly into a backplane board. The backplane board provides module to module

interconnection as well as interconnection to remote command and control connectors. Refer to the block diagram drawing (1302139), located in Appendix B, for the exciter amplifier chassis assembly connections.

2.1.1 (Optional) (A1) Receiver Module Assembly (VHF LB 1304000, VHF HB 1304001 or UHF 1304002; Appendix B)

NOTE: The Receiver module is not present in a transmitter or digital system.



<p>A1 RECEIVER MODULE (NOT USED IN DIGITAL OR TRANSMITTER SYSTEMS)</p>	<p>ON CHANNEL RF I/P: -55 dBm to -25 dBm IF OUTPUT: -2 TO +2dBm PK SYNC 44 MHz (5MHz BW) POWER REQUIREMENTS: +12V @ 1.1-1.6A -12V @ 380mA</p>
---	--

NOTE: If both the Receiver and Modulator are present in your system the Modulated IF output from the Receiver or Modulator must be selected. This is accomplished by connecting a low or removing the low to TB31-Pin 3 located on the rear of the exciter/driver assembly. By connecting the low, the Modulator IF output is used by the IF Processor module. By removing the low, the IF from the internal or external

Receiver is used. (**NOTE:** The IF Processor board must be configured for external switching by placing jumper W11 on J29 between pins 1 & 2).

amplifies the signal, filters off any unwanted out of band energy and controls its own IF gain to make sure that the IF output level is constant.

The UHF/VHF Receiver converts a low level RF input signal to an IF frequency of 44 MHz, filters off any unwanted out of band energy, and normalizes the level so that it can be applied to the IF processor assembly. It consists of three boards. The RF input is applied first to the UHF/VHF preamplifier board, which filters off out of channel energy and amplifies the input signal. The RF output is applied to the Mixer/PLL board, which converts the signal down to an IF frequency of 44 MHz. The IF output is applied to the IF ALC board, which

There is also a provision to apply +12V to the RF input center conductor to power an external preamplifier.

CAUTION: Do not hook up the RF input to any test equipment with the DC bias applied. Always move the jumper W1 on J2, on the UHF Preamplifier Board, to the Bias off position, between pins 2 & 3, to prevent possible damage to the test equipment.

Table 2-2. Receiver Front Panel Switch

SWITCH	FUNCTION
MAN/AUTO ALC SW1	When Manual ALC is selected, the level is set by the Manual ALC Pot R57 located on the mixer/PLL board. (NOTE: The pot is factory set and needs no adjustment by the customer). When Auto ALC is selected, the level control circuit will automatically increase or decrease the ALC to maintain the desired output level.

Table 2-3. Receiver Front Panel Status Indicators

LED	FUNCTION
PLL1 Fault DS6	Displays the status of the Local oscillator PLL
PLL 2 Fault DS8	Displays status of optional input frequency correcting PLL
DC on center conductor DS4	Displays whether or not DC is applied to the RF input center conductor
Man ALC Gain DS7	Displays when ALC is switched to Manual bypass
ALC Fault DS5	Displays ALC status

Table 2-4. Receiver Front Panel Control Adjustments

POTENTIOMETERS	DESCRIPTION
Manual Gain R57	Adjusts the gain of the receiver when the ALC is bypassed.
A/V Ratio R50	Adjusts the ratio between the visual and aural carriers.

Table 2-5. Receiver Front Panel Samples

SMA CONNECTORS	DESCRIPTION
Receiver IF J13	Sample of the IF output of the IF ALC Board.
Receiver LO J2	Sample of the LO generated on the UHF Mixer PLL Board.

**2.1.2 (A2) Modulator Module
Assembly (1301929; Appendix B)**

NOTE: The Modulator module may not be present in a translator system or in a digital system.



(A2) MODULATOR MODULE (NOT USED IN DIGITAL OR TRANSLATOR SYSTEMS)	VIDEO I/P: ♂ - 1V PK-PK COMPOSITE AUDIO: ♂ - 1V PK-PK SAP/PRG: ♂ - 1V PK-PK BASEBAND AUDIO: ♂ - +10dBm 10MHz I/P: ♂ - +8dBm IF OUTPUT: -2 TO +240mV PK SYNC 44 MHz (8MHz BW)
	POWER REQUIREMENTS: +12V @ 1.1-1.5A -12V @ 300mA

NOTE: If both the Modulator and Receiver are present in your system the Modulated IF output from the Modulator or Receiver must be selected. This is accomplished by connecting a low or

removing the low to TB31-Pin 3 located on the rear of the exciter/driver assembly. By connecting the low, the Modulator IF output is used by the IF Processor module. By removing the low, the IF from the internal or external Receiver is used. (NOTE: The IF Processor board must be configured for external switching by placing jumper W11 on J29 between pins 1 & 2).

The (A2) Modulator Assembly contains the Modulator Board (1301797). The modulator is broadcast quality and provides front panel access to control and monitoring points. The video level is controlled through a sync tip clamp and sync and white clipping circuitry. The IF oscillator is oven controlled and locked to a 10 MHz reference for stability. The IF signal is fed through a SAW filter for precise sideband shaping. The Modulator operates using the baseband audio and video inputs to produce a diplexed, modulated, and on-channel frequency visual + aural RF output that is cabled to the IF Processing Module.

Table 2-6. Modulator Front Panel Switch

SWITCH	FUNCTION
MAN/AUTO CLAMP SW1	When Manual Clamp is selected, the video level is set by the Manual Bias Pot R67 located on the board. (NOTE: The pot is factory set and needs no adjustment by the customer). When Auto Clamp is selected, the video level control circuit will automatically increase or decrease the video to maintain the desired video level.

Table 2-7. Modulator Front Panel Status Indicators

LED	FUNCTION
AUR UNLOCK DS5 (Red)	When lit it indicates that the 4.5 MHz VCO and the 10 MHz reference are not PLL locked.
VIS UNLOCK DS6 (Red)	When lit it indicates that the 45.75 MHz VCXO and the 10 MHz reference signal are not PLL locked.
AUD OV DEV DS4 (Red)	When lit it indicates the deviation level is more than ± 80 kHz
VIDEO LOSS DS1 (Red)	When lit it indicates the Video Input to the transmitter is lost.

OVER MOD DS3 (Red)	When lit it indicates the Video input level is too high.
ALT IF DS7 (Green)	When lit it indicates that external or alternate 4.5MHZ is present.
10 MHz PRES DS2 (Green)	When lit it indicates that a 10MHz reference is present to the transmitter.

Table 2-8. Modulator Front Panel Control Adjustments

POTENTIOMETERS	DESCRIPTION
Video Gain (R42)	Adjusts the level of the output video.
Visual Level (R214)	Adjusts the Visual IF level that combines with the Aural IF.
Aural Level (R243)	Adjusts the Aural IF level that combines with the Visual IF.
MONO (R110)	Adjusts the deviation level of the balanced audio input.
STEREO (R132)	Adjusts the deviation level of the composite audio input.
SAP/PRO (R150)	Adjusts the deviation level of the subcarrier audio input.

Table 2-9. Modulator Front Panel Sample

SMA CONNECTOR	DESCRIPTION
MOD IF SAMPLE (J10)	Sample of the combined Aural IF and Visual IF signals.

**2.1.3 (A3) IF Processor Module
Assembly (1301938; Appendix B)**

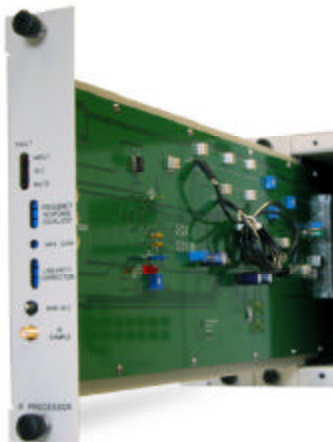

A3 IF PROCESSING MODULE	IF INPUT: 44MHz (6MHz BW) INPUT LEVEL: -2 TO +2 dBm PK SYNC. MODULATOR & RECEIVER INPUT RETURN LOSS: > 15dB IF OUTPUT LEVEL: -10dBm TO -0dBm PEP IF SAMPLE LEVEL: -21dB POWER REQUIREMENTS: +12V @ 800mA -12V @ 100mA
-------------------------------	---

The (A3) IF Processor Assembly contains the IF Processor Board (1301977). The IF Processor provides pre-correction to ensure broadcast quality output signal. The pre-correction consists of amplitude linearity correction, Incidental Carrier Phase Modulation (ICPM) correction and frequency response correction.

The IF Processor module is configured either for an analog or digital system. Pin 13C of the IF Processor module is grounded in analog systems and left not connected in digital systems. An IF Processor Interlock signal is used to report the presence of the IF Processor module to the Control Monitoring board. If the IF Processor interlock signal is not present, the LX Series Transmitter/Exciter Driver RF output is Muted (turned off). If an analog IF Processor module is installed and the Modulation Present signal is not true, the LX Series Transmitter/Exciter Driver output is Muted (turned off).

The Control & Monitoring/Power Supply module uses the IF Processor module for System output power control. Through the front panel display or a remote interface, an operator can set the RF output power level of the transmitter. The range of RF power adjustment is between 0% (full off) and 105% (full power plus). A front panel IF Processor module potentiometer sets the upper limit of RF power at 120%. The system's Control Monitoring board compares the RF Power Monitoring

module RF power level with the desired level and uses the IF Power Control PWM line to correct for errors.

In digital systems, a digital level control (DLC) voltage is generated on the IF Processor module and sent to an external digital modulator (DT1B/C). RF power control is implemented by changing the DLC voltage provided to the external digital modulator. The 'RF High' potentiometer sets the upper adjusted range of RF control circuit output to 120%.

The IF Processor module provides a reference ALC voltage to the system's Upconverter. When the ALC voltage decreases, the Upconverter automatically lowers the system output power through the AGC circuits.

The IF Processor module has a front panel switch to select Auto or Manual ALC. When Manual ALC is selected, the reference ALC voltage is set by a front panel potentiometer. In this condition,

the RF power level control circuit is removed from use. When the ALC select switch is changed to Auto, the RF power level control circuit will start at low power and increase the RF output until the desired output power is attained.

The IF Processor module Modulation Present signal is monitored. If the modulation level is too low or non-existent, a Modulation Present Fault is reported to the Control Monitoring board. When the controller detects this fault, it can be set to Automatically Mute the transmitter or in Manual mode the transmitter will continue to operate at 25% output.

The IF Processor module Input Signal level is monitored. If the signal level is too low or non-existent, an Input Fault is reported on the Control Monitoring board. When the IF Processor board detects an Input Signal Fault it automatically Mutes the transmitter. The system controller does not Mute on an IF Processor Input Fault.

Table 2-10. IF Processor Front Panel Switch

SWITCH	FUNCTION
MAN/AUTO ALC	When Manual ALC is selected, the reference ALC voltage is set by the ALC Gain front panel potentiometer. When Auto ALC is selected, the IF level control circuit will automatically increase the IF output until the desired output power is attained.

Table 2-11. IF Processor Front Panel Status Indicators

LED	FUNCTION
INPUT FAULT (Red)	When lit it indicates that there is a loss of the IF Input signal to the IF Processor. Transmitter can be set to Mute on an IF Input Fault.
ALC Fault (Red)	When lit it indicates that the required gain to produce the desired output power level has exceeded the operational range of the ALC circuit. The LED will also be lit when ALC is in Manual.
MUTE (Red)	When lit it indicates that the IF input signal is cut back but the enable to the Power Supply is present and the +32 VDC remains on.

Table 2-12. IF Processor Front Panel Control Adjustments

POTENTIOMETERS	DESCRIPTION
FREQUENCY RESPONSE EQUALIZER	These three variable resistors, R103, R106 & R274, adjust the depth of gain for the three stages of frequency response correction.
ALC GAIN	Adjusts the gain of the transmitter when the transmitter is in the Auto ALC position.
MAN GAIN	Adjusts the gain of the transmitter when the transmitter is in the Manual ALC position.
LINEARITY CORRECTION	These three variable resistors adjust the threshold cut in for the three stages of linearity pre-correction. R211 and R216, the top two pots, are adjusted to correct for in phase amplitude distortions. R 231, the bottom pot, is adjusted to correct for quadrature phase distortions.

Table 2-13. IF Processor Front Panel Sample

SMA CONNECTOR	DESCRIPTION
IF SAMPLE	Sample of the pre-corrected IF output of the IF Processor

2.1.4 (A5) VHF/UHF Upconverter Module Assembly (1303829; Appendix B)



A5 VHF/UHF UPCONVERTER MODULE	IF INPUT: 44 MHz
	INPUT RETURN LOSS: 18dB MIN @ 41-47 MHz
	INPUT LEVEL: 0dBm PK SYNC
	CONVERSION GAIN: 0 ± 1.5dB
	RF OUTPUT: CH 2-69, -10 TO +10dBm
	10MHz INPUT LEVEL: 0 TO +8dBm
	LO 1 SAMPLE LEVEL: -10dBm
	LO 2 SAMPLE LEVEL: -10dBm
	LO TUNING STEP SIZE: 10kHz
	POWER REQUIREMENTS: +12V @ 1.2-1.1A
	-12V @ 10mA

The VHF/UHF Upconverter Module Assembly contains (A1) a Downconverter Board Assembly (1303834), (A3) a First Conversion Board, LX Series (1303838), (A2) a L-Band PLL Board, LX Series (1303846) and (A4) an Upconverter Control Board (1304760).

A 0 dBm 44 MHz IF input to the upconverter through the backplane board is applied to a mixer mounted on the first conversion board. Also applied to the mixer is a nominal 1 GHz LO1. The mixer converts it to a nominal frequency centered at 1044 MHz. A filter selects the appropriate conversion product, which is then amplified to a level of approximately -4 dBm. The frequency of the first conversion LO1 can be shifted by ± 10 kHz to generate channel offsets of 10kHz. For +offsets the frequency is 999.99 MHz and for -offsets the frequency is 1000.01 MHz.

This signal is applied to a second mixer mounted on the downconverter board that converts it back to a broadcast channel (2-69) by an LO2 that operates in 100kHz steps between 1.1-1.9 GHz depending on the channel selected. The LO2 frequency equals the Channel center frequency plus the LO1 frequency plus 44 MHz. (As an example CH14+ : Center Frequency is 473.01 MHz and LO1 is 999.99 MHz therefore LO2 is 473.01 + 999.99 + 44, which equals 1517.00 MHz.)

The output of the mixer is applied to a 900 MHz Low pass filter to remove unwanted conversion products. The

resulting signal is amplified and applied to a Pin diode attenuator before it is connected to the output of the upconverter. This pin diode attenuator adjusts the gain of the module and is

controlled by an Automatic Gain Control circuit, which maintains a constant power out of the upconverter, and also the transmitter, that connects to the power amplifier module.

Table 2-14. VHF/UHF Upconverter Front Panel Switch

SWITCH	FUNCTION
MAN/AUTO AGC (Left Manual, Right AGC)	When Manual AGC is selected, the reference AGC voltage is set by the AGC Manual Gain front panel potentiometer. When Auto AGC is selected, the RF power level control circuit will automatically increase the RF output until the desired output power is attained.

Table 2-15. VHF/UHF Upconverter Front Panel Status Indicators

LED	FUNCTION
PLL 1 Fault (Red)	When lit it indicates that the 1 GHz PLL is unlocked
PLL 2 Fault (Red)	When lit it indicates that the 1.1 –1.9 GHz PLL is unlocked
AGC Fault (Red)	When lit it indicates that the AGC is out of range.
AGC Override (Red)	When lit it indicates that the AGC is cutting back due to too much drive to the driver module.
Man Gain (Amber)	When lit it indicates that the AGC is bypassed in Manual.

Table 2-16. VHF/UHF Upconverter Front Panel Control Adjustments

POTENTIOMETERS	DESCRIPTION
MAN GAIN ADJ	Adjusts the gain of the upconverter and transmitter when in the Manual AGC position.
AGC ADJ	Adjusts the gain of the upconverter and transmitter when in the Auto AGC position.
AGC CUTBACK ADJ (AGC OVERRIDE)	Adjusts the point at which the transmitter will cut back in power, due to too much drive, when the Transmitter is in Auto AGC.

Table 2-17. VHF/UHF Upconverter Front Panel Samples

SMA CONNECTOR	DESCRIPTION
LO1 SAMPLE	Sample of the 1 GHz nominal LO1 signal in the Upconverter as generated on the L-Band PLL Board.
LO2 SAMPLE	Sample of the 1.1-1.9 GHz LO2 signal in the Upconverter as generated on the First Conversion Board.
RF SAMPLE	Sample of the On Channel RF Output of the Upconverter

**2.1.5 (A4) Control/Power Supply
Module Assembly (110 VAC,
1301936 or 220 VAC, 1303229;
Appendix B)**



A4 CONTROL/ MONITORING MODULE	POWER REQUIREMENTS: +12V @ 200mA -12V @ 50mA
A4-A1 POWER SUPPLY	AC INPUT LEVEL: 100-240VAC @ 10A 50/60/400Hz DC OUTPUT LEVEL: +32V @ 15A +12V @ 8A -12V @ 4A

The (A4) Control & Monitoring/Power Supply Assembly is configured at the factory for operation at 110 VAC or 220 VAC. The assembly made up of a Control Board (1302021), a Power Protection Board (1302837) and a Switch Board (1527-1406). The Assembly also contains a switching power supply that provides ± 12 VDC to the rest of the modules in the chassis and +32 VDC to the Power Amplifier module.

The Assembly provides all transmitter control and monitoring functions. The Front panel LCD allows monitoring of system parameters, including forward and reflected power, transistor currents, module temperatures and power supply voltages. The LCD screens are detailed in Chapter 3.

Table 2-18. Controller/Power Supply Display

DISPLAY	FUNCTION
LCD	A 4 x 20 display providing a four-line readout of the internal functions, external inputs, and status. See Chapter 3, Controller/Power Supply Display Screens, for a listing of displays.

Table 2-19. Controller/Power Supply Status Indicator

LED	FUNCTION
OPERATE (green)	When lit it indicates that the transmitter is in the Operate Mode. If transmitter is Muted the Operate LED will stay lit, the transmitter will remain in Operate, until the input signal is returned.
FAULT (red or green)	Red indicates that a problem has occurred in the transmitter. The transmitter will be Muted or placed in Standby until the problem is corrected.
DC OK (red or green)	Green indicates that the switchable fuse protected DC outputs that connect to the modules in the transmitter are OK.

Table 2-20. Controller/Power Supply Control Adjustments

POTENTIOMETERS	DESCRIPTION
DISPLAY CONTRAST	Adjusts the contrast of the display for desired viewing of screen.

2.1.6 (A6) Exciter Power Amplifier Module in 10-100W Transmitter or driver in systems above 2kW (1303770; Appendix B)



A6 POWER AMPLIFIER	RF INPUT/OUTPUT:	470 - 880 MHz
	INPUT LEVEL:	+10dBm ±2dB PK SYNC.
	INPUT RETURN LOSS:	-10dB
	OUTPUT LEVEL:	+51dBm (120W PK SYNC)
	POWER REQUIREMENTS:	+32V @ 12A +12V @ 0.2A -12V @ 0.5A

NOTE: The (A6) Power Amplifier Module Assembly (1303770) is used in the 10-100 Watt Transmitter or as a driver in systems above 2kW.

The (A6) Power Amplifier Module Assembly is made up of a Coupler Board Assembly (1301949), an Amplifier Control Board (1303682 or 1301962), a 1 Watt Module Assembly (1302891), a 40W UHF Module (1304490) and a RF Module Pallet, Philips (1300116).

The Power Amplifier Module contains Broadband LDMOS amplifiers that cover the entire UHF band with no tuning required. They amplify the RF to the 10 to 100W output power level of the transmitter or the drive level needed to achieve the output power from the external PA assemblies.

The Power Amplifier of the Transmitter/Exciter Driver is used to amplify the RF output of the Upconverter module. A cable, located on the rear chassis, connects the RF output from the LO/Upconverter at J23 to J24 the RF input to the PA Assembly. This module contains RF monitoring circuitry for both an analog and a digital system. Control and monitoring lines to the

Power Amplifier module are routed through the floating blind-mate connector of the Control & Monitoring/Power Supply module.

The 100 Watt Transmitter/Exciter Driver Power Amplifier module and any External Amplifier modules contain the same control and monitoring board. This board monitors RF output power, RF reflected power, the current draw of amplifier sections, the supply voltage, and the temperature of the PA heat sink.

The RF power detector circuit outputs vary with operating frequency. These circuits must be calibrated at their intended operating frequency. Front panel adjustment potentiometers are used to calibrate the following:

Power Amplifier Calibration Adjustments in Analog Systems

- R201 Reflected Power Cal
- R202 Visual/Forward Power Cal
- R203 Aural Power Cal
- R204 Visual Offset Zero
- R205 Aural Null

In analog systems, the Aural power of an Exciter Driver Power Amplifier and the Aural power of any external amplifier will not be reported by the system Control Monitoring module. Additionally the Visual power of these amplifiers, is reported as Forward Power just like in digital systems. In analog systems, aural and visual power will only be reported for the final system RF output.

If the Control Monitoring module is monitoring a 5-50 Watt digital or 10-100 Watt analog Transmitter, system power is measured in the Power Amplifier module. The wired connections are transferred through the power supply connector to the backplane board on a five position header. All four positions of control board switch SW1 must be set on to route these lines as the system's RF power signals. In systems of output power greater than 50 Watts digital or

100 Watts analog, system power is monitored by an external module that is connected to TB31 and control board SW1 switches must be set off.

The Forward Power of the Transmitter/Exciter Driver Power Amplifier module is routed to the Upconverter module as AGC #1. A

system over-drive condition is detected when this value rises above 0.9 VDC. When an over-drive condition is detected, the Upconverter module reduces its RF output level. For values less than 0.9 VDC, the Upconverter uses this voltage for automatic gain.

Table 2-21. Power Amplifier Status Indicator

LED	FUNCTION
ENABLED (Green)	When lit Green, it indicates that the PA is in the Operate Mode. If a Mute occurs, the PA will remain Enabled, until the input signal is returned.
DC OK (Green)	When lit Green, it indicates that the fuse protected DC inputs to the PA module are OK.
TEMP (Green)	When lit Green, it indicates that the temperature of the heatsink assembly in the module is below 78°C.
MOD OK (Green)	When lit Green, it indicates that the PA Module is operating and has no faults.
MOD OK (Red)	If the Module OK LED is Red and blinking a fault is present. 1 Blink indicates Amplifier Current Fault. 2 Blinks indicate Temperature Fault. 3 Blinks indicate +32V Power Supply Over Voltage Fault. 4 Blinks indicate +32V Power Supply Under Voltage Fault. 5 Blinks indicate Reflected Power Fault. 6 Blinks indicate +12V or -12V Power Supply Fault.

Table 2-22. Power Amplifier Control Adjustments

POTENTIOMETERS	DESCRIPTION
RFL CAL	Adjusts the gain of the Reflected Power monitoring circuit
VISUAL CAL	Adjusts the gain of the Visual / Forward Power monitoring circuit
AURAL CAL	Adjusts the gain of the Aural Power monitoring circuit
VISUAL ZERO	Adjusts the offset of the Forward Power monitoring circuit
AURAL NULL	Adjusts the offset of the Forward Power monitoring circuit based on the Aural signal level.

Table 2-23. Power Amplifier Sample

DISPLAY	FUNCTION
FWD SAMPLE	RF sample of the amplified signal being sent out the module on J25.

2.1.6.1 (A6) Driver Amplifier Module Assembly {1303771(1kW) or 1303874(2kW); Appendix B}



A6 DRIVER AMPLIFIER MODULE	RF INPUT/OUTPUT: 470 – 860 MHz INPUT LEVEL: +10dBm ±2dB PK SYNC. INPUT RETURN LOSS: -10dB OUTPUT LEVEL: +38.5dBm (7W PK SYNC) POWER REQUIREMENTS: +32V @ 2A +12V @ 0.2A -12V @ 0.5A
---	--

NOTE: The (A6) Driver Amplifier Module Assembly {1303771(1kW) or 1303874(2kW)} replaces the Power Amplifier Module Assembly (1303770) when the amplifier module is used as a driver for any external PA assemblies.

The (A6) Power Amplifier Module Assembly is made up of a Coupler Board Assembly (1227-1316), an Amplifier Control Board (1303682 or 1301962), a 1 Watt Module Assembly (1302891) and a 40W UHF Module (1304490).

The Driver Power Amplifier Module contains Broadband LDMOS amplifiers that cover the entire UHF band with no tuning required. They amplify the RF to the power level, 7 Watts Peak of Sync is maximum, that is needed to drive the external amplifiers to the output power level of the transmitter. The Driver Power Amplifier is used to amplify the RF output of the Upconverter module. A cable, located on the rear chassis, connects the RF output from the LO/Upconverter at J23 to J24 the RF input to the driver PA Assembly. This module contains RF monitoring circuitry for both an analog and a digital system. Control and monitoring lines to the Driver Power Amplifier module are routed through the floating blind-mate connector of the Control & Monitoring/Power Supply module.

The Driver Power Amplifier module and any External Amplifier modules contain the same control and monitoring board. This board monitors RF output power, RF reflected power, the current draw of amplifier sections, the supply voltage, and the temperature of the PA heat sink.

The RF power detector circuit outputs vary with operating frequency. These circuits must be calibrated at their intended operating frequency. Front panel adjustment potentiometers are used to calibrate the following:

Power Amplifier Calibration Adjustments in Analog Systems

- R201 Reflected Power Cal
- R202 Visual/Forward Power Cal
- R203 Aural Power Cal
- R204 Visual Offset Zero
- R205 Aural Null

In analog systems, the Aural power of an Exciter Driver Power Amplifier and the Aural power of any external PA amplifiers will not be reported by the system Control Monitoring module. Additionally the Visual power of these amplifiers, is reported as Forward Power just like in digital systems. In analog systems, aural and visual power will only be reported for the final system RF output.

In digital systems, the Forward power of an Exciter Driver Power Amplifier and the Forward power of any external amplifiers, are reported by the system Control Monitoring module.

If the Control Monitoring module is monitoring a 10-100 Watt Transmitter, system power is measured in the Power Amplifier module. The wired connections are transferred through the power supply connector to the backplane board on a five position header. All four positions of control board switch SW1 must be set on to route these lines as the system's RF power signals. In systems of output

power greater than 100 Watts, system power is monitored by an external module that is connected to TB31. In this configuration switches SW1 on the control board must be set off.

The Forward Power of the Exciter Driver Power Amplifier module is routed to the Upconverter module as AGC #1. A

system over-drive condition is detected when this value rises above 0.9 VDC. When an over-drive condition is detected, the Upconverter module reduces its RF output level.

For values less than 0.9 VDC, the Upconverter uses this voltage for automatic gain.

Table 2-24. Driver Amplifier Status Indicator

LED	FUNCTION
ENABLED (Green)	When lit Green, it indicates that the PA is in the Operate Mode. If a Mute occurs, the PA will remain Enabled, until the input signal is returned.
DC OK (Green)	When lit Green, it indicates that the fuse protected DC inputs to the PA module are OK.
TEMP (Green)	When lit Green, it indicates that the temperature of the heatsink assembly in the module is below 78°C.
MOD OK (Green)	When lit Green, it indicates that the PA Module is operating and has no faults.
MOD OK (Red)	If the Module OK LED is Red and blinking a fault is present. 1 Blink indicates Amplifier Current Fault. 2 Blinks indicate Temperature Fault. 3 Blinks indicate +32V Power Supply Over Voltage Fault. 4 Blinks indicate +32V Power Supply Under Voltage Fault. 5 Blinks indicate Reflected Power Fault. 6 Blinks indicate +12V or -12V Power Supply Fault.

Table 2-25. Driver Amplifier Control Adjustments

POTENTIOMETERS	DESCRIPTION
RFL CAL	Adjusts the gain of the Reflected Power monitoring circuit
VISUAL CAL	Adjusts the gain of the Visual / Forward Power monitoring circuit
AURAL CAL	Adjusts the gain of the Aural Power monitoring circuit
VISUAL ZERO	Adjusts the offset of the Forward Power monitoring circuit
AURAL NULL	Adjusts the offset of the Forward Power monitoring circuit based on the Aural signal level.

Table 2-26. Driver Amplifier Sample

DISPLAY	FUNCTION
FWD SAMPLE	RF sample of the amplified signal being sent out the module on J25.

2.1.7 RF Output Assemblies

The RF output from the exciter power amplifier is at the RF output jack, an "N" connector J25, PA RF Output, of the chassis assembly. If the exciter assembly is used as a driver, the output connects to the input of the PA Assembly mounted beneath the exciter assembly. If the exciter assembly is used as a 10W to 100W transmitter, then the output connects directly to the bandpass filter for the system.

The RF output of the transmitter is typically connected to a bandpass filter and then to a trap filter mounted on the rear of the assembly. The bandpass and trap filters are tuned to eliminate unwanted sideband and harmonic frequencies. Located on the output of the trap filter is a BNC output sample jack that can be used for test purposes.

2.2 Control and Status

The control and status readings of the exciter/amplifier Chassis assembly are found by operating the front panel display screen on the front of the assembly. Detailed information on the use of the screens is found in chapter 3.

2.2.1 Front Panel Display Screens

A 4 x 20 display located on the front of the Control & Monitoring/Power Supply Module is used in the LX Series transmitter for control of the operation and display of the operating parameters of the transmitter. Refer to Chapter 3 for descriptions of the screens.

2.3 System Operation

When the transmitter is in operate, as set by the menu screen located on the Control & Monitoring Module, the following occurs. The IF Processor will be enabled and the mute indicator on the front panel will be extinguished. The +32 VDC stage of the Power Supply in the Control & Monitoring Module is enabled, the operate indicator on the

front panel is lit and the DC OK on the front panel should also be green. The enable and DC OK indicators on the PA Module will also be green.

When the transmitter is in standby. The IF Processor will be disabled, the mute indicator on the front panel will be red. The +32 VDC stage of the Power Supply in the Control & Monitoring Module is disabled, the operate indicator on the front panel will be extinguished and the DC OK on the front panel should remain green. The enable indicator on the PA Module is also extinguished.

If the transmitter does not switch to Operate when the operate menu is switched to Operate, check that all faults are cleared and that the remote control terminal block stand-by signal is not active.

The transmitter can be controlled by the presence of a modulated input signal. If the input signal to the transmitter is lost, the transmitter will automatically cutback and the input fault indicator on the IF Processor module will light. When the video input signal returns, the transmitter will automatically return to full power and the input fault indicator will be extinguished.

2.3.1 Principles of Operation

Operating Modes

This transmitter is either operating or in standby mode. The sections below discuss the characteristics of each of these modes.

Operate Mode

Operate mode is the normal mode for the transmitter when it is providing RF power output. To provide RF power to the output, the transmitter will not be in mute. Mute is a special case of the operate mode where the +32 VDC section of the power supply is enabled but there is no RF output power from

the transmitter. This condition is the result of a fault that causes the firmware to hold the IF Processor module in a mute state.

Operate Mode with Mute Condition

The transmitter will remain in the operate mode but will be placed in mute when the following fault conditions exist in the transmitter.

- Upconverter is unlocked
- Upconverter module is not present
- IF Processor module is not present
- Modulator (if present) is in Aural/Visual Mute

Entering Operate Mode

Entering the operate mode can be initiated a few different ways by the transmitter control board. A list of the actions that cause the operate mode to be entered is given below:

- A low on the Remote Transmitter Operate line.
- User selects "OPR" using switches and menus of the front panel.
- Receipt of an "Operate CMD" over the serial interface.

There are several fault or interlock conditions that may exist in the transmitter that will prevent the transmitter from entering the operate mode. These conditions are:

- Power Amplifier heat sink temperature greater than 78°C.
- Transmitter is Muted due to conditions listed above.
- Power Amplifier Interlock is high indicating that the amplifier is not installed.

Standby Mode

The standby mode in the transmitter indicates that the output amplifier of the transmitter is disabled.

Entering Standby Mode

Similar to the operate mode, the standby mode is entered using various means. These are:

- A low on the Remote Transmitter Stand-By line.
- Depressing the "STB" key on selected front panel menus.
- Receipt of a "Standby CMD" over the serial interface.

Auto Standby Mode

The FCC requires that certain transmitters automatically switch to standby operation on loss of video input. The LX Series transmitter incorporates this feature as a user configurable setting. When Auto Stand-By on modulation loss is selected in the set-up menus, the transmitter temporarily switches to standby after ten seconds of modulation loss. When the modulated signal as reported by the IF Processor module is again present, the transmitter automatically returns to Operate mode. This feature is implemented in transmitter software versions 1.4 and above.

RF System Interlock

A RF System Interlock signal is provided through TB30-5. When this signal's circuit is completed to ground such as through a wire between TB30-5 and TB30-15, the transmitter is allowed to operate. If this circuit is opened, the transmitter switches to a Mute condition. This circuit may be completed through coax relay contacts and reject load contact closures to assure the RF output system is available to receive the transmitter's output RF signal. This feature is implemented in transmitter software versions 1.4 and above.

Table 2-27: UHF Television Frequencies

CH #	CENTER FREQUENCY	+ Offset	- Offset	CH #	CENTER FREQUENCY	+ Offset	- Offset
14	473 MHz	473.01	472.99	42	641 MHz	641.01	640.99
15	479 MHz	479.01	478.99	43	647 MHz	647.01	646.99
16	485 MHz	485.01	484.99	44	653 MHz	653.01	652.99
17	491 MHz	491.01	490.99	45	659 MHz	659.01	658.99
18	497 MHz	497.01	496.99	46	665 MHz	665.01	664.99
19	503 MHz	503.01	502.99	47	671 MHz	671.01	670.99
20	509 MHz	509.01	508.99	48	677 MHz	677.01	676.99
21	515 MHz	515.01	514.99	49	683 MHz	683.01	682.99
22	521 MHz	521.01	520.99	50	689 MHz	689.01	688.99
23	527 MHz	527.01	526.99	51	695 MHz	695.01	694.99
24	533 MHz	533.01	532.99	52	701 MHz	701.01	700.99
25	539 MHz	539.01	538.99	53	707 MHz	707.01	706.99
26	545 MHz	545.01	544.99	54	713 MHz	713.01	712.99
27	551 MHz	551.01	550.99	55	719 MHz	719.01	718.99
28	557 MHz	557.01	556.99	56	725 MHz	725.01	724.99
29	563 MHz	563.01	562.99	57	731 MHz	731.01	730.99
30	569 MHz	569.01	568.99	58	737 MHz	737.01	736.99
31	575 MHz	575.01	574.99	59	743 MHz	743.01	742.99
32	581 MHz	581.01	580.99	60	749 MHz	749.01	748.99
33	587 MHz	587.01	586.99	61	755 MHz	755.01	754.99
34	593 MHz	593.01	592.99	62	761 MHz	761.01	760.99
35	599 MHz	599.01	598.99	63	767 MHz	767.01	766.99
36	605 MHz	605.01	604.99	64	773 MHz	773.01	772.99
37	611 MHz	611.01	610.99	65	779 MHz	779.01	778.99
38	617 MHz	617.01	616.99	66	785 MHz	785.01	784.99
39	623 MHz	623.01	622.99	67	791 MHz	791.01	790.99
40	629 MHz	629.01	628.99	68	797 MHz	797.01	796.99
41	635 MHz	635.01	634.99	69	803 MHz	803.01	802.99

Operating Frequency

The LX Series transmitter/translator controller is designed to operate on UHF frequencies. Refer to Table 2-27 for the typical UHF channel center and + & - offset frequencies, which are used in setting the LO1 and LO2 frequencies in the Upconverter Module. The exact output frequency of the transmitter can be set to one of the standard UHF frequencies, or to a custom frequency using the software channel set-up menu on the Controller Module. Since RF performance of the transmitter requires different hardware for different frequency bands, not all frequency configurations are valid for a specific transmitter. The Power detectors in the transmitter are frequency dependent, therefore detectors of power amplifiers are calibrated at their frequency of use. The detectors for System RF monitoring are also calibrated at the desired frequency of use.

2.4 Maintenance

The Innovator LX Series Driver/Transmitter/translator is designed with components that require little or no periodic maintenance except for the routine cleaning of the fans and the front panels of the modules.

The amount of time between cleanings depends on the conditions within the transmitter room. While the electronics have been designed to function even if covered with dust, a heavy buildup of dust, dirt, or insects will affect the cooling of the components. This could lead to a thermal shutdown or the premature failure of the affected module.

When the front panels of the modules become dust covered, the module should be pulled out and any accumulated foreign material should be removed.

NOTE: To remove the driver/power amplifier module, mounted in the exciter/driver assembly, the input and

output cables must be removed from the rear of the module and also a 6/32" x 1/2" Philips screw, mounted between the two connectors, needs to be removed before the module will pull out. After removal of the screw, which is used to hold the module in place during shipping, it does not need to be replaced.

NOTE: To remove the Combiner Module, found in the power amplifier assembly in high power transmitters, the output cable must be removed from the rear of the module and also two 8/32" x 1/2" Philips screws, mounted above the connector, need to be removed before the module will pull out. After removal of the screws, which are used to hold the module in place during shipping, they do not need to be replaced.

A vacuum cleaner, utilizing a small, wand-type attachment, is an excellent way to suction out the dirt. Alcohol and other cleaning agents should not be used unless you are certain that the solvents will not damage components or the silk-screened markings on the modules and boards. Water-based cleaners can be used, but do not saturate the components. The fans and heatsinks should be cleaned of all dust or dirt to permit the free flow of air for cooling purposes.

It is recommended that the operating parameters of the driver/transmitter be recorded from the LEDs on the modules and the LCD system metering on the control/monitoring module at least once a month. It is suggested that this data be retained in a rugged folder or envelope.

2.5 Customer Remote Connections

The remote monitoring and operation of the transmitter is provided through jacks TB30 and TB31 located on the rear of the chassis assembly. If remote connections are made to the transmitter, they must be made through plugs TB30 and TB31 at positions noted on the transmitter interconnect drawing and Table 2-28.

If your system contains the Optional Exciter Switcher Assembly, there are also remote connections that can be made to the Exciter Switcher Assembly. They connect to TB1 on the rear of the exciter

switcher tray. Refer to Table 2-29 and to the Exciter Switcher Board schematic drawing (1305705) located in Appendix B for the pin out and descriptions.

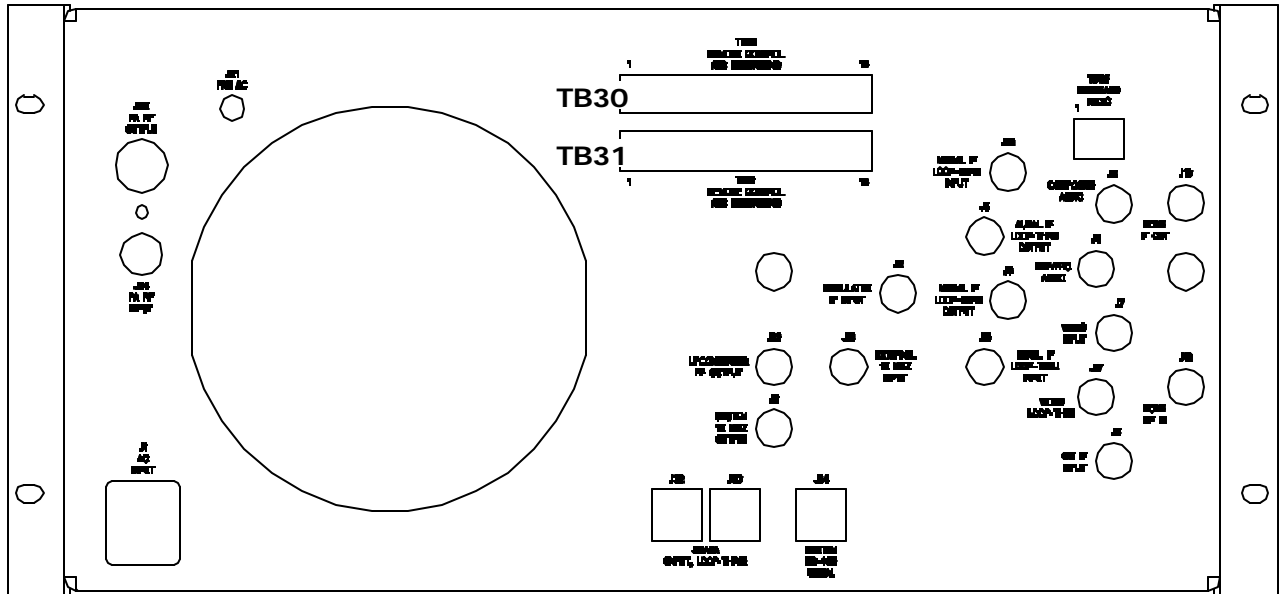

Figure 2-2. Exciter/Driver Chassis Assembly Rear View

Table 2-28: LX Series Chassis Assembly Hard Wired Remote Interface Connections to TB30 or TB31, 18 pos. Terminal Blocks Located on the Rear of the Assembly

Signal Name	Pin Designations	Signal Type/Description
RMT Transmitter State	TB30-1	Discrete Open Collector Output - A low indicates that the transmitter is in the operate mode.
RMT Transmitter Interlock	TB30-2	Discrete Open Collector Output - A low indicated the transmitter is OK or completes a interlock daisy chain. When the transmitter is not faulted, the interlock circuit is completed.
RMT Transmitter Interlock Isolated Return	TB30-3	Ground - Configurable ground return which can be either jumpered directly to ground or it can be the "source" pin of an FET so that the transmitter interlock can be daisy chained with other transmitters. This signal does not directly interface to the microcontroller.
RMT AUX IO 1	TB30-4	Discrete Open Collector Inputs, Discrete Open Drain Outputs, or 0 - 5 VDC Analog Input - When used as an output, this line is pulled to +5 VDC with a 1.0 kΩ resistor for logic high and pulled to ground for a low. A diode allows this line to be pulled up to 12 VDC. When used as a digital input, this line considers all values over 2 Volts as high and those under 1 volt as low. As an analog input, this line is protected by a 5.1 zener diode.

Signal Name	Pin Designations	Signal Type/Description
RMT RF System Interlock	TB30-5	When this signal's circuit is completed to ground such as through a jumper between TB30-5 and TB30-15, the transmitter is allowed to operate. If this circuit is opened, the transmitter switches to a Mute condition. Implemented in transmitter software versions 1.4 and above.
RMT Transmitter Operate	TB30-6	Discrete Open Collector Input - A pull down to ground on this line indicates that the transmitter is to be placed into the operate mode.
RMT Transmitter Stand-By	TB30-7	Discrete Open Collector Input - A pull down to ground on this line indicates that the transmitter is to be placed into the standby mode.
RMT Power Raise	TB30-8	Discrete Open Collector Input - A pull down to ground on this line indicates that the transmitter power is to be raised.
RMT Power Lower	TB30-9	Discrete Open Collector Input - A pull down to ground on this line indicates that the transmitter power is to be lowered.
RMT System Reflect Power	TB30-10	Analog Output (0 to 4.0 V). This is a buffered loop through of the calibrated "System Reflected Power " and indicates the transmitter's reflected output power. The scale factor is 25% = 3.2V.
RMT System Visual/Forward Power	TB30-11	Analog Output (0 to 4.0 V). This is a buffered loop through of the calibrated "System Visual/Avg. Power ". Indicates the transmitter's Visual / Average power. Scale factor is 100% = 3.2V.
RMT System Aural Power	TB30-12	Analog Output (0 to 4.0 V). This is a buffered loop through of the calibrated "System Aural Power ". Indicates the transmitter's forward Aural output power. The scale factor is 100% = 3.2V.
RMT Spare 1	TB30-13	Remote connection to spare module - Use is TBD.
RMT Spare 2	TB30-14	Remote connection to spare module - Use is TBD.
System Reflect Power	TB31-13	Analog Input (0 to 1.00 V). This is the input of the "System Reflected Power " indicating the transmitter's reflected output power. The scale factor is 25% = 0.80V.
System Visual / Forward Power	TB31-14	Analog Input (0 to 1.00 V). This is the input of the "System Visual / Forward Power " indicating the transmitter's forward Visual / Forward output power. The scale factor is 100% = 0.80V.
System Aural Power	TB31-15	Analog Input (0 to 1.00 V). This is the input of the "System Aural Power " indicating the transmitter's forward Aural output power. The scale factor is 100% = 0.80V.
IF Processor IF Signal Select	TB31-3	Discrete Open Collector Input – By connecting a low to this pin, the Modulator IF source is used by the IF Processor module. When floating the IF from the internal or external Receiver is used. (NOTE: The IF Processor board must be configured for external switching by placing jumper W11 on J29 between pins 1 & 2).

Signal Name	Pin Designations	Signal Type/Description
IF Processor DLC Voltage	TB31-4	Analog Output (0 to 5.00 V). This is the input of IF Processor module for digital system RF output power control.
UC AGC #2 Voltage	TB31-5	Auxiliary Analog Input (0 to 1V). This voltage is used by the Upconverter for gain control. Linear signal with display resolution of 0.01 %. Primary signal source is J34-1.
RMT Ground	TB30-15, and 17	Ground pins available through Remote
RMT Ground	TB31-1, 2, 6 to 12, and 17	Ground pins available through Remote
RMT +12 VDC	TB30-16 TB31-16	+12 VDC available through Remote w/ 2 Amp re-settable fuse
RMT -12 VDC	TB30-18 TB31-18	-12 VDC available through Remote w/ 2 Amp re-settable fuse

Table 2-29: (Optional) Exciter Switcher Hard Wired Remote Interface Connections to TB1, 18 pos. Terminal Block are located on the Rear of the Exciter Switcher Tray Assembly.

Signal Name	Pin Designations	Signal Type/Description
Select Automatic Operation	TB1-1	0 = SET, NC = No Change
Select Manual Operation	TB1-2	0 = SET, NC = No Change
Select Exciter A (1)	TB1-3	0 = SET, NC = No Change
Select Exciter B (2)	TB1-4	0 = SET, NC = No Change
Selected Exciter to Operate	TB1-5	0 = SET, NC = No Change
Selected Exciter to Standby	TB1-6	0 = SET, NC = No Change
Selected Exciter Power Raise	TB1-7	0 = SET, NC = No Change
Selected Exciter Power Lower	TB1-8	0 = SET, NC = No Change
Selected Exciter Aural Power Raise	TB1-9	0 = SET, NC = No Change
Selected Exciter Aural Power Lower	TB1-10	0 = SET, NC = No Change
Ground	TB1-11	Ground
Selected Operation	TB1-12	0 = Auto, Open = Manual
Selected Exciter	TB1-13	0 = A, Open = B
Selected Exciter State	TB1-14	0 = OK, Open = Fault

Signal Name	Pin Designations	Signal Type/Description
Selected Exciter Interlock Status	TB1 - 15	0 = OK, Open = Fault
Alternate Exciter State	TB1 - 16	0 = OK, Open = Fault
Alternate Exciter Interlock Status	TB1 - 17	0 = OK, Open = Fault
Ground	TB1 - 18	Ground

Chapter 3 Site Considerations, Installation and Setup Procedures

Table 3-1: LX Series Transmitters/Drivers AC Input and Current Requirements.

Transmitter/ Driver	Voltage	Current
10 Watt	117/220 VAC	5 Amps
100 Watt	117/220 VAC	10 Amps
250 Watt	220 VAC	10 Amps to the Exciter/Amplifier Cabinet
500 Watt	220 VAC	15 Amps to the Exciter/Amplifier Cabinet
1000 Watt	220 VAC	25 Amps to the Exciter/Amplifier Cabinet
2000 Watt	220 VAC	45 Amps to the Exciter/Amplifier Cabinet
3000 Watt	220 VAC	65 Amps to the Exciter/Amplifier Cabinet
4000 Watt	220 VAC	45 Amps to the Exciter/Amplifier Cabinet
	220 VAC	40 Amps to the Amplifier Cabinet
5000 Watt	220 VAC	55 Amps to the Exciter/Amplifier Cabinet
	220 VAC	50 Amps to the Amplifier Cabinet
6000 Watt	220 VAC	65 Amp to the Exciter/Amplifier Cabinet
	220 VAC	60 Amps to the Amplifier Cabinet

3.1 Site Considerations

There are special considerations that need to be taken into account before the Innovator LX Series analog driver/transmitter can be installed. For example, if the installation is completed during cool weather, a heat-related problem may not surface for many months, suddenly appearing during the heat of summer. This section provides planning information for the installation and set up of the driver/transmitter.

The AC input and current requirements for LX Series transmitters are shown in Table 3-1.

NOTES: The transmitter is factory set for either 110 VAC or 220 VAC operation as directed by customer. Transmitters 250 Watts or above use 220 VAC Input only. Transmitters 4000 Watts and above require two 220 VAC Inputs, one to the exciter/driver and one to the amplifier cabinet. All currents are with a Black picture

Check that your site has the needed power requirements.

The LX Series Analog Transmitters are designed and built to provide long life with a minimum of maintenance. The environment in which they are placed is important and certain precautions must be taken. The three greatest dangers to the transmitter are heat, dirt, and moisture. Heat is usually the greatest problem, followed by dirt, and then moisture. Over-temperature can cause heat-related problems such as thermal runaway and component failure. Each amplifier module in the transmitter contains a thermal interlock protection circuit that will shut down that module until the temperature drops to an acceptable level.

A suitable environment for the transmitter can enhance the overall performance and reliability of the transmitter and maximize revenues by minimizing downtime. A properly designed facility will have an adequate supply of cool, clean air, free of airborne particulates of any kind, and no excessive humidity. An ideal environment will require temperature in the range of 40° F to 70° F throughout the year, reasonably low humidity, and a dust-free room. It should be noted that this is

rarely if ever attainable in the real world. However, the closer the environment is to this design, the greater the operating capacity of the transmitter.

The fans are designed and built into the transmitter will remove the heat from within the modules, but additional means are required for removing this heat from the building. To achieve this, a few issues need to be resolved. The first step is to determine the amount of heat to be removed from the transmitter room. There are generally three sources of heat that must be considered. The first and most obvious is the heat from the transmitter itself. This amount can be determined for a 100 Watt transmitter by subtracting the average power to the antenna (69.5 watts) from the AC input power (675 watts) and taking this number in watts (605.5) and then multiplying it by 3.41. This gives a result of 2,065, the BTUs to be removed every hour. 12,000 BTUs per hour equals one ton. Therefore, a 1/4-ton air conditioner will cool a 100W transmitter.

The second source of heat is other equipment in the same room. This number is calculated in the same way as the equation for BTUs. The third source of heat is equally obvious but not as simple to calculate. This is the heat coming through the walls, roof, and windows on a hot summer day. Unless the underside is exposed, the floor is usually not a problem. Determining this number is usually best left up to a qualified HVAC technician. There are far too many variables to even estimate this number without reviewing the detailed drawings of the site that show all of the construction details. The sum of these three sources is the bulk of the heat that must be removed. There may be other sources of heat, such as personnel, and all should be taken into account. Now that the amount of heat that must be removed is known, the next step is to determine how to accomplish this. The options are air conditioning, ventilation, or a combination of the two. Air conditioning is always the

preferred method and is the only way to create anything close to an ideal environment.

Ventilation will work quite well if the ambient air temperature is below 100° F, or about 38° C, and the humidity is kept at a reasonable level. In addition, the air stream must be adequately filtered to ensure that no airborne particulates of any kind will be carried into the transmitter. The combination of air conditioning for summer and ventilation during the cooler months is acceptable when the proper cooling cannot be obtained through the use of ventilation alone and using air conditioning throughout the year is not feasible.

Caution: The use of air conditioning and ventilation simultaneously is not recommended. This can cause condensation in the transmitters.

The following precautions should be observed regarding air conditioning systems:

1. Air conditioners have an ARI nominal cooling capacity rating. In selecting an air conditioner, do not assume that this number can be equated to the requirements of the site. Make certain that the contractor uses the actual conditions that are to be maintained at the site in determining the size of the air conditioning unit. With the desired conditioned room temperature under 80° F, the unit must be derated, possibly by a substantial amount.
2. Do not have the air conditioner blowing directly onto the transmitter. Under certain conditions, condensation may occur on, or worse in, the transmitter.
3. Do not separate the front of the transmitter from the back with the

- thought of air conditioning only the front of the unit. Cooling air is drawn in at the front of all transmitters and in the front and back of others. Any attempt to separate the front of the transmitter from the rear of the unit will adversely affect the flow of cooling air.
4. Interlocking the transmitter with the air conditioner is recommended to keep the transmitter from operating without the necessary cooling.
 5. The periodic cleaning of all filters is a must.
- When using ventilation alone, the following general statements apply:
1. The blower, with attendant filters, should be on the inlet, thereby pressurizing the room and preventing dirt from entering the transmitter.
 2. The inlet and outlet vents should be on the same side of the building, preferably the leeward side. As a result, the pressure differential created by wind will be minimized. Only the outlet vent may be released through the roof.
 3. The inlet and outlet vents should be screened with 1/8-inch hardware cloth (preferred) or galvanized hardware cloth (acceptable).
 4. Cooling air should enter the room as low as practical but in no case higher than four feet above the floor. The inlet must be located where dirt, leaves, snow, etc., will not be carried in with the cooling air.
 5. The exhaust should be located as high as possible. Some ducting is usually required to insure the
- complete flushing of heated air with no stagnant areas.
6. The filter area must be large enough to insure a maximum air velocity of 300 cubic feet per minute through the filter. This is not a conservative number but a never-exceed number. In a dusty or remote location, this number should be reduced to 150 CFM.
 7. The inlet and outlet(s) must have automatic dampers that close any time the ventilation blower is off.
 8. In those cases in which a transmitter is regularly off for a portion of each day, a temperature-differential sensor that controls a small heater must be installed. This sensor will monitor inside and outside temperatures simultaneously. If the inside temperature falls to within 5° F of the outside temperature, the heater will come on. This will prevent condensation when the ventilation blower comes on and should be used even in the summer.
 9. A controlled air bypass system must be installed to prevent the temperature in the room from falling below 40° F during transmitter operation.
 10. The blower should have two speeds, which are thermostatically controlled, and are interlocked with the transmitter. The blower on high speed must be capable of moving the required volume of air into a half inch of water pressure at the required elevation. The free air delivery method must not be used.
 11. Regular maintenance of any filters can not be overemphasized.

12. Above 4000 feet, for external venting, the air vent on the cabinet top must be increased to an 8-inch diameter for a 1 kW transmitter and to a 10 inch diameter for 5 kW and 6 kW transmitters. An equivalent rectangular duct may be used but, in all cases, the outlet must be increased by 50% through the outlet screen.
13. It is recommended that a site plan be submitted to Axcera for comments before installation begins.

feet, larger for dusty and remote locations, for each 5000 watts or 17,000 BTUs. The exhaust must be at least four square feet at the exhaust screen for each 5000 watts or 17,000 BTUs.

The information presented in this section is intended to serve only as a general guide and may need to be modified for unusually severe conditions.

A combination of air conditioning and ventilation should not be difficult to design (see Figure 3-1).

System interlocking and thermostat settings should be reviewed with Axcera. As with any equipment installation, it is always good practice to consult the manufacturer when questions arise. Axcera can be contacted at (724) 873-8100.

In calculating the blower requirements, filter size, and exhaust size, if the total load is known in watts, 2000 CFM into ½ inch of water will be required for each 5000 watts. If the load is known in BTUs, 2000 CFM into ½ inch of water will be required for each 17,000 BTUs. The inlet filter must be a minimum of seven square

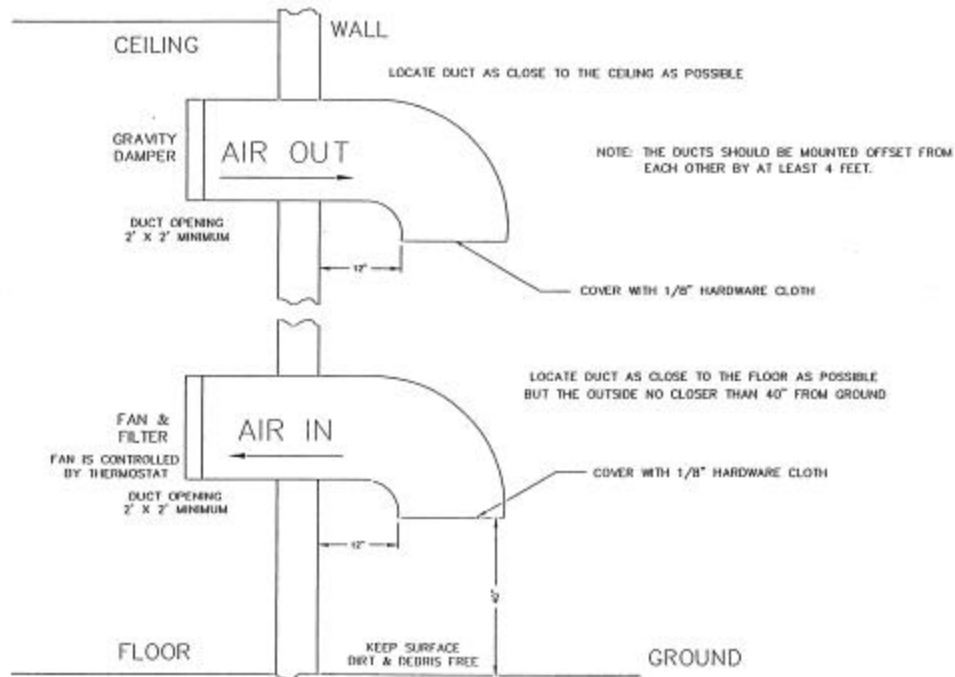

Figure 3-1. 1 kW Minimum Ventilation Configuration

3.2 Unpacking the Chassis w/modules, bandpass and trap filters

Thoroughly inspect the cabinet, if purchased, chassis with modules and all other materials upon their arrival. Axcera certifies that upon leaving our facility the equipment was undamaged and in proper working order. The shipping containers should be inspected for obvious damage that indicates rough handling. Remove the cabinet, if purchased, chassis and modules, along with bandpass filter and trap Filter, from the crates and boxes. Check for dents and scratches or broken connectors, switches, display, or connectors. Any claims against in-transit damage should be directed to the carrier. Inform Axcera as to the extent of any damage as soon as possible.

The modules are mounted to the chassis assembly with slides that are on the top and the bottom of the modules. There are two thumb screws on the front panel that hold each of the modules in place.

NOTE: Typically the transmitter is shipped installed into a cabinet and the following sections may be skipped.

3.3 Installing the Chassis w/modules and filters

The chassis assembly is made to mount in a standard 19" rack. The chassis

assembly mounts using the four #10 clearance mounting holes on the ends. The chassis should be positioned; to provide adequate air intake into the front and the air exhaust of the fan(s) in the rear; the ability to slide the modules out for replacement purposes; the installation of the bandpass filter and trap filter; the coupler assembly; and output transmission line. The chassis or cabinet in which it is mounted should be grounded using copper strapping material.

NOTE: To remove the driver/power amplifier module, mounted in the exciter/driver assembly, the input and output cables must be removed from the rear of the module and also a 6/32" x 1/2" Philips screw, mounted between the two connectors, needs to be removed before the module will pull out. After removal of the screw, which is used to hold the module in place during shipping, it does not need to be replaced. (See Figure 3-2)

NOTE: To remove the Combiner Module, found in the power amplifier assembly in high power transmitters, the output cable must be removed from the rear of the module and also two 8/32" x 1/2" Philips screws, mounted above the connector, need to be removed before the module will pull out. After removal of the screws, which are used to hold the module in place during shipping, they do not need to be replaced.

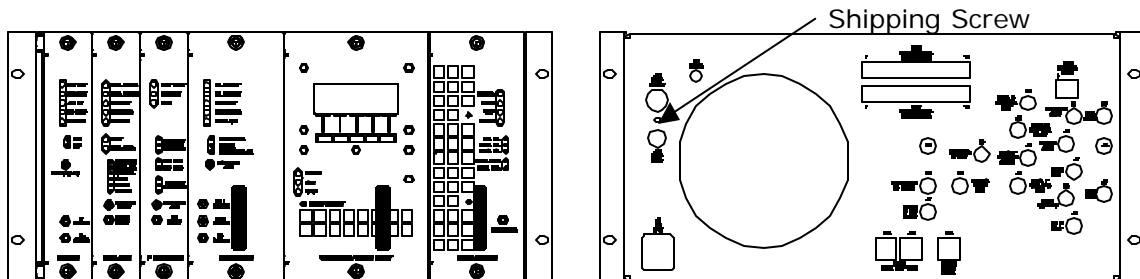
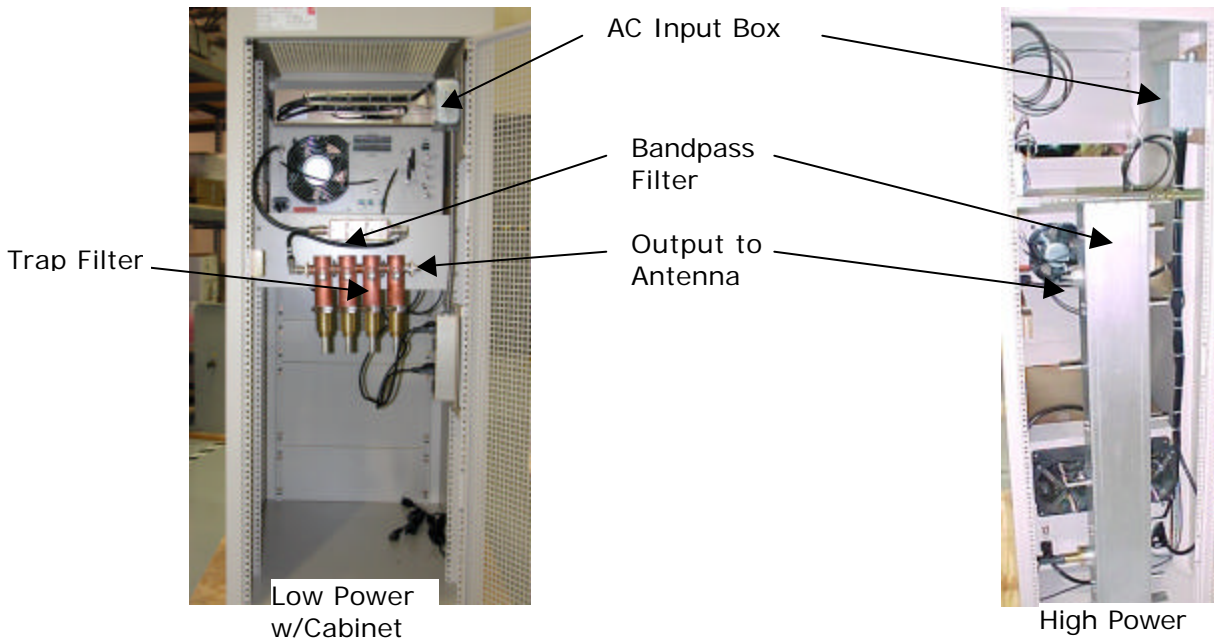

Figure 3-2. Front and Rear View Reconnection Drawing



Connect the bandpass filter and trap filter to the output of the chassis assembly. Connect the transmission line for the antenna system to the output of the trap filter. A BNC sample jack of the output on the trap filter can be used for test purpose.

3.4 AC Input

Once the chassis and output connections are in place, connect the AC power cord from the chassis assembly of the 10 watt or 100 watt transmitter to an AC outlet.

The AC input and current requirements for LX Series transmitter/drivers are as follows.

Table 3-2: LX Series Transmitters AC Input and Current Requirements.

Transmitter/Driver	Voltage	Current
10 Watt	117/220 VAC	5 Amps
100 Watt	117/220 VAC	10 Amps
250 Watt	220 VAC	10 Amps to the Exciter/Amplifier Cabinet
500 Watt	220 VAC	15 Amps to the Exciter/Amplifier Cabinet
1000 Watt	220 VAC	25 Amps to the Exciter/Amplifier Cabinet
2000 Watt	220 VAC	45 Amps to the Exciter/Amplifier Cabinet
3000 Watt	220 VAC	65 Amps to the Exciter/Amplifier Cabinet
4000 Watt	220 VAC	45 Amps to the Exciter/Amplifier Cabinet
	220 VAC	40 Amps to the Amplifier Cabinet
5000 Watt	220 VAC	55 Amps to the Exciter/Amplifier Cabinet
	220 VAC	50 Amps to the Amplifier Cabinet
6000 Watt	220 VAC	65 Amp to the Exciter/Amplifier Cabinet
	220 VAC	60 Amps to the Amplifier Cabinet

NOTES: The transmitter is factory set for either 110 VAC or 220 VAC operation as directed by customer. Transmitters 250 Watts and above use 220 VAC Input only.

Transmitters 4000 Watts and above require two 220 VAC Inputs, one to each cabinet.

All currents are with a Black picture.

The AC Input to the high power transmitter connects to the terminal block mounted in the AC input box located toward the rear, right side near the top of the cabinet. Connect the AC Input Line 1 to Line 1 on the terminal block, the AC Input Line 2 to Line 2 on the terminal block and the AC Input Ground to Ground on the terminal block.



Figure 3-3: AC Input Box Assembly

NOTE: When the AC power cord for the exciter/amplifier chassis is plugged in, or the AC is connected to the AC input box, the AC is always connected to the transmitter.

This completes the unpacking and installation of the LX Series UHF

television transmitter. Refer to the setup and operation procedures that follow before applying power to the transmitter.

3.5 Setup and Operation

Initially, the transmitter should be turned on with the RF output at the Trap Filter terminated into a dummy load of at least the power rating of the transmitter. If a load is not available, check that the output of the trap filter is connected to the antenna for your system.

3.5.1 Input Connections

The input connections to the transmitter or translator are to the rear of the Chassis Assembly. **NOTE:** In dual exciter systems input connections must be made to the rear of both exciters.

Refer to the table and description that follows for detailed information on the input connections.

NOTE: If both the Receiver and Modulator are present in your system the Modulated IF output from the Receiver or Modulator must be selected. This is accomplished by connecting a low or removing the low to TB31-Pin 3 located on the rear of the exciter/driver assembly. By connecting the low, the Modulator IF output is used by the IF Processor module. By removing the low, the IF from the internal or external Receiver is used. (**NOTE:** The IF Processor board must be configured for external switching by placing jumper W11 on J29 between pins 1 & 2).

Figure 3-4: Rear View of LX Series Analog Transmitter

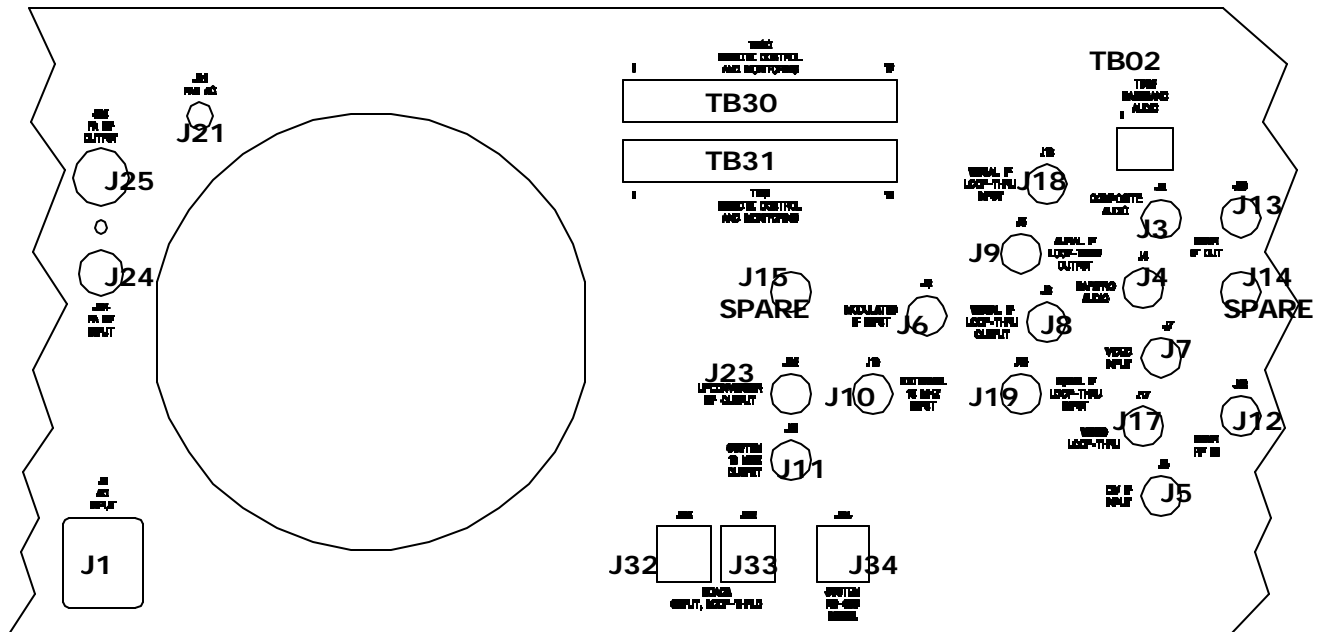

Table 3-3: Rear Chassis Connections for the LX Series Analog Transmitter.

Port	Type	Function	Impedance
J1	IEC	AC Input	N/A
TB02	Term	Base Band Audio Input	6000
J3	BNC	Composite Audio Input	750
J4	BNC	SAP / PRO Audio Input	500
J5	BNC	CW IF Input	500
J6	BNC	Modulated IF Input	500
J7	BNC	Video Input (Isolated)	750
J8	BNC	Visual IF Loop-Thru Output	500
J9	BNC	Aural IF Loop-Thru Output	500
J10	BNC	External 10 MHz Reference Input	500
J11	BNC	System 10 MHz Reference Output	500
J12	BNC	Receiver RF Input	500
J13	BNC	Receiver IF Output	500
J14	BNC	RF Spare 2	500
J15	BNC	RF Spare 1	500
J17	BNC	Video Loop-Thru (Isolated) (May be connected to second exciter)	750
J18	BNC	Visual IF Loop-Thru Input	500
J19	BNC	Aural IF Loop-Thru Input	500
J23	BNC	Upconverter RF Output	500
J24	BNC	Power Amplifier RF Input	500
J25	N	Power Amplifier RF Output	500
TB30	Termination	Remote Control & Monitoring	N/A
TB31	Termination	Remote Control & Monitoring	N/A

Port	Type	Function	Impedance
J32	RJ-45	SCADA (Input / Loop-Thru)	CAT5
J33	RJ-45	SCADA (Input / Loop-Thru)	CAT5
J34	RJ-45	System RS-485 Serial	CAT5

3.5.2 Initial Turn On

Once the unit has been installed and all connections have been made, the process of turning on the equipment can begin. First verify that AC power is present and connected to the transmitter. Verify all cables are properly connected and are the correct type. Once all of these things are done, the unit is ready to be turned on following the procedures below.

NOTE: In systems with two exciters and an exciter switcher, repeat the following procedure with Exciter B as the On Air exciter. The exciter switcher must in Manual.

Turn on the main AC power source that supplies the AC to the transmitter. Check that the AC power plug is connected to J1 on the rear of the chassis assembly.

Monitor the LCD display located on the front of the control/monitoring module as you proceed through this section. When the transmitter is in the operate mode, the STB menu appears. When in the standby mode, the OPR menu appears. Press the NXT key after each menu to continue through the sequence.

3.5.2.1 (Optional) Receiver Module LEDs on Front Panel

Fault Indicators:

PLL 1 FLT: This illuminates Red when the Local Oscillator PLL is unlocked.

PLL 2 FLT: This illuminates Red when the optional input frequency correcting PLL is unlocked.

ALC FLT: This illuminates Red when the ALC can not maintain output level.

Status Indicators:

DC ON I/P: This indicator will illuminate Red when DC is applied to the RF input center conductor.

MAN ALC: This illuminates Red when the ALC can not maintain output level..

3.5.2.2 Modulator Module LEDs on Front Panel

Fault Indicators:

AUR UNLOCK: This illuminates Red when the Aural IF PLL is unlocked.

VIS UNLOCK: This illuminates RED when the Visual IF PLL is unlocked.

AUD OV DEV: This indicator will illuminate Red when the audio over-deviates the aural carrier.

VIDEO LOSS: This indicates the loss of Video to the modulator, when Red.

OVER MOD: This illuminates Red when the video is over-modulated.

Status Indicators:

ALT IF CW: This indicates that there is an external IF CW signal applied to the Modulator

10MHz PRES: This indicates the presence of a 10 MHz reference input.

3.5.2.3 IF Processor Module LEDs on Front Panel

Fault Indicators:

INPUT FAULT: This illuminates Red if the input to the module is missing or low.

ALC FAULT: This illuminates RED when the needed ALC value to maintain the output level is beyond the range of the circuitry.

MUTE: This indicator will illuminate Red when the transmitter is muted.

3.5.2.4 VHF/UHF Upconverter Module LEDs on Front Panel

Fault Indicator:

AGC FAULT: This illuminates Red if the required gain to produce the desired output level is beyond the value set by the AGC circuit. AGC out of range.

AGC OVERRIDE: This illuminates Red if the drive to the driver module is too high.

MAN GAIN: This illuminates Red if the AGC is bypassed in Manual.

PLL 1: This illuminates Red if the 1 GHz PLL is unlocked.

PLL 2: This illuminates Red if the 1.1-1.9 GHz PLL is unlocked.

3.5.2.5 Controller Module LEDs on Front Panel

Status Indicators:

OPERATE: This illuminates Green when transmitter is in operate.

FAULT: This illuminates Red when a fault has occurred in the transmitter.

DC OK: This illuminates Green when the DC outputs that connect to the modules in the transmitter are present.

3.5.2.6 Power Amplifier or Driver Module LEDs on Front Panel

NOTE: Both the PA Module and Driver Module have the same front panel LEDs.

Status Indicators:

ENABLED: This illuminates Green when the PA is in operate.

DC OK: This illuminates Green when the DC inputs to the PA module are present.

TEMP: This illuminates Green when the temperature of the heatsink in the PA is below 78°C.

MOD OK: This illuminates Green when the PA module is operating and has no faults.

If the Module OK LED is Red and blinking a fault is present. The meaning of the blinking LED is as follows.

1 Blink: Indicates Amplifier Current Fault.

2 Blinks: Indicate Temperature Fault.

3 Blinks: Indicate +32V Power Supply Over Voltage Fault.

4 Blinks: Indicate +32V Power Supply Under Voltage Fault.

5 Blinks: Indicate Reflected Power Fault.

6 Blinks: Indicate +12V or -12V Power Supply Fault

3.5.3 Front Panel Screens for the (Optional) Exciter Switcher Assembly

(Used in Dual Exciter Systems only)

The following screens are found on the 4 x 20 display located on the front of the single channel exciter switcher tray.

Display Menu Screens for the (Optional) Exciter Switcher Tray

Table 3-4: Menu 01 - Splash Screen #1

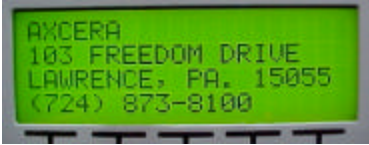

This is the first of the two exciter switcher splash screens that is shown for the first few seconds after reset or after pushing the SPL button on the Main Screen. Will automatically switch to the second splash screen.

Table 3-5: Menu 02 - Splash Screen #2

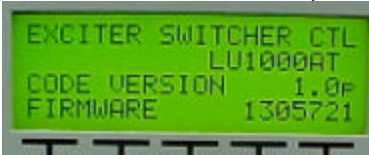

This is the second of the two exciter switcher splash screens. Will automatically switch to the Main Screen. The Name, Model Number, Code Version Number and Firmware Number for your system are displayed on this screen. Make note of these two numbers when conferring with Axcera on software problems.

Table 3-6: Menu 03 – Exciter Switcher Control Screen

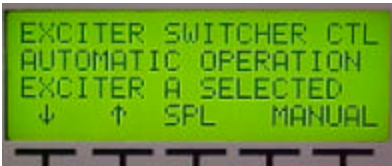

This screen indicates that the exciter switcher is in automatic back-up and that Exciter A is selected as the On Air Exciter. By selecting MANUAL the screen is shown as below.

Table 3-7: Menu 04 – Exciter Switcher Control Screen

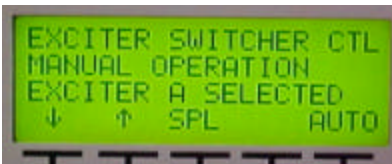

This screen indicates that the exciter switcher is in Manual operation and that Exciter A is selected as the On Air Exciter.

Table 3-8: Menu 05 – Exciter Switcher Control Screen

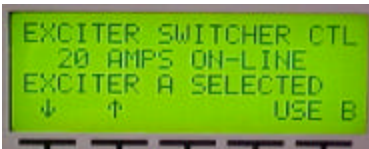

This screen indicates that there are 20 External Amplifiers reporting serial data in the system. Also indicates that Exciter A is selected as the On Air Exciter and that the system is in Manual, because the USE B option is present on the screen. By pushing the button under USE B you are able to select Exciter B as the ON Air Exciter.

Table 3-9: Menu 06 – Exciter Switcher Control Screen



This screen allows you to cancel the automatic back-up and that Exciter B is selected as the On Air Exciter.

Table 3-10: Menu 07 – Exciter Switcher Control Screen

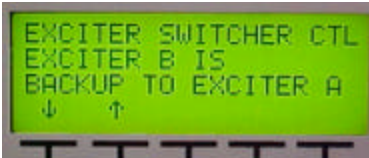

This screen indicates that Exciter B is selected as Back up to the On Air Exciter A.

Table 3-11: Menu 08 – Exciter Switcher Control Screen

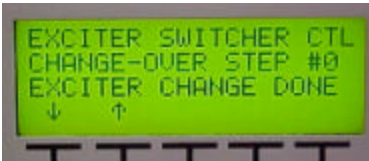

This screen is only displayed when an exciter back up sequence is initiated. The backup sequence runs through 10 steps that are displayed on 10 different screens. 9) Exciter A/B On, 8) Disabling Exciter A, 7) Disabling Exciter B, 6) Changing Relay 1 of 2, 5) Changing Relay 2 of 2, 4) Waiting for Relays, 3) Relay Change Done, 2) Enabling Exciter A, 1) Enabling Exciter B; 0) Exciter Change Done. If a problem occurs during the sequence it will stop on the screen where the problem occurred.

Table 3-12: Menu 09 – External Amplifier Status



These screens indicate the Status of the different Amplifier Modules. This screen is monitoring the power supply for Module 1 in Amplifier Set 1. By arrowing down, the next parameter for that module is viewed and these screens will continue for each individual module in each Amplifier Set.

Table 3-13: Menu 10 – External Amplifier Status with Serial Link Error Icon



Serial Link Icon
Indicates that this module is not present in your System or the module may be present but no serial communication commands are being received from the device.

3.5.4 Front Panel Screens for the Exciter/Amplifier Chassis Assembly

A 4 x 20 display located on the front of the Control & Monitoring/Power Supply Module is used in the LX Series transmitter for control of the operation and display of the operating parameters of the transmitter. Below are the typical display screens for the system and may vary depending on your system. The ↑ and ↓ characters are special characters used to navigate up or down through the

menu screens. Display text flashes on discrete fault conditions for all screens that display a fault condition. When the transmitter is in operate mode, the STB menu appears. When the transmitter is in standby mode, the OPR menu appears.

NOTE: In systems with two exciters and an exciter switcher the following screens are typical on the exciter that is selected as the On Air Exciter.

Display Menu Screens for the LX Series Transmitter/Translator

Table 3-14: Menu 01 - Splash Screen #1



This is the first of the two transmitter splash screens that is shown for the first few seconds after reset or after pushing the SPL button on the Main Screen. Will automatically switch to the second splash screen.

Table 3-15: Menu 02- Splash Screen #2



This is the second of the two transmitter splash screens. Will automatically switch to the Main Screen. The Model Number, Code Version Number and Firmware Number for your system are displayed on this screen. Make note of these two numbers when conferring with Axcera on software problems.

Table 3-16: Menu 10 - Main Screen:

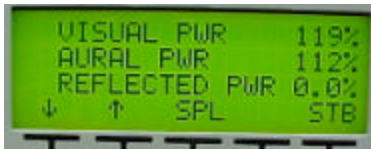

This is the default main screen of the transmitter. When the transmitter is in operate, the 'STB' characters appear, allowing an operator to place the transmitter in STANDBY, by pushing the right most button located under to display. When the transmitter is in standby the 'STB' characters are replaced with 'OPR' and the forward power values are displayed as OFF. An operator can change the transmitter from STANDBY to OPERATE by pressing the right most button on the front panel display. If the transmitter is in operate mode but off due to a modulation fault, the display reports the system power as Auto Off. Pushing the SPL button will display the two splash screens. If the ↓ key is activated the display changes to Menu 11, the System Error List Access Screen. If the ↑ key is activated the display changes to Menu 13, the Transmitter Configurations Access Screen.

Table 3-17: Menu 11 - Error List Access Screen



This screen of the transmitter shows the current number of errors, displayed in upper, right of screen (0), and provides operator access to view Menu 20, the error list screens, by pushing the ENT button. When ENT is pushed, Menu 20, the Error List Display Screen is displayed. If the ↓ key is pushed the display changes to Menu 12, Table 3-18, the Transmitter Device Data Access Screen. If the ↑ key is activated the display returns to Menu 10, the Main Screen.

Table 3-18: Menu 12 - Transmitter Device Data Access Screen



This screen of the transmitter allows access to various parameters of the transmitter system. This is the entry point to Menu 30, the System Details Screens, by pausing the ENT button. When the ENT button is pushed, Menu 30 is accessed. Go to Menu 30, Table 3-23 for set up details. Before pushing the ENT button: if the ↓ key is activated the display changes to Menu 13, Transmitter Configurations Access Screen. If the ↑ key is activated the display returns to Menu 11, the Error List Access Screen.

Table 3-19: Menu 13 - Transmitter Configuration Access Screen



This screen of the transmitter allows access to various software settings of the transmitter system. If ENT is pushed, go to Menu 40, Table 3-24, the access to transmitter configuration and set up. Before pushing the ENT button: if the ↓ key is activated the display returns to Menu 10, Main Screen. If the ↑ key is activated the display returns to Menu 12, the Transmitter Device Data Access Screen.

Table 3-20: Menu 20 - Error List Display Screen

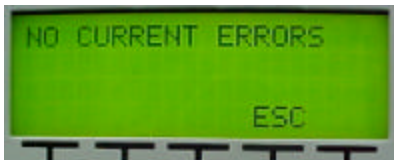

This screen of the transmitter allows access to the system faults screens. Fault logging is stored in non-volatile memory. The transmitter's operating state can not be changed in this screen. The 'CLR' switch is used to clear previously detected faults that are no longer active. The ↑ key and ↓ key allow an operator to scroll through the list of errors that have occurred. The ESC button is used to leave this screen and return to Menu 11, Table 3-17, the Error List Access Screen. **NOTE:** Shown is example of a typical screen.

Menu 30 is entered by selecting ENT at Menu 12, Table 3-8.

Table 3-21: Menu 30 - Transmitter Device Details Screen



This screen allows access to the transmitter parameters of installed devices. The system is configured to know which devices are present. Current values for all installed devices are shown. If a module is not installed, only a "MODULE NOT PRESENT" message will be displayed. The first screen displayed is Menu 30-1, Table 3-22, the System Details Screen.

Table 3-22: Menu 30-1 – System Details Screen



The ↓ and ↑ arrows allow you to scroll through the different parameters of each device as shown in **Table 3-23**. Each System Component is a different screen. The proper IF Processor and the Driver or the Power Amplifier will be programmed for your system. The External Amplifier Modules will only be used in high power transmitters. Examples of External Amplifier Modules displays are: (AMP SET 1 MODULE 1) and (AMP SET 2 MODULE 4).

Table 3-23: Transmitter Device Parameters Detail Screens

System Component	Parameter	Normal	Faulted (Blinking)
Receiver Details (Not used with transmitter.)	AFC 1 LEVEL	0 - 10.00 V	N/A
	PLL 1 CIRCUIT	LOCKED	UNLOCKED
	ALC INPUT	OK	FAULT
	FAULT AT	0 - 10.00 V	FAULT
Modulator Details (May Not be used with receiver.)	PLL CIRCUIT	LOCKED	UNLOCKED
	OUTPUT LEVEL	.24 – 1.00 V	N/A
	AURAL DEVIATION	0 - 125 kHz	N/A
	CW INPUT	PRESENT	NOT USED
IF Processor Details (Analog Systems)	CALL SIGN	NONE	N/A
	INPUT SIGNAL STATE	OK	FAULT
	MODULATION	OK	FAULT
	INPUT IF	MODULATOR or J6	N/A
	DLC CONTROL LOCK	0 - 5.00 V	N/A
	ALC LEVEL	0 - 5.00 V	N/A
(OR) IF Processor Details (Digital Systems)	ALC MODE	AUTO or MANUAL	N/A
	ALC LEVEL	0 - 5.00 V	N/A
	ALC MODE	AUTO or MANUAL	N/A
	DLC LEVEL	0 - 5.00 V	N/A

System Component	Parameter	Normal	Faulted (Blinking)
Upconverter Details	AFC 1 LEVEL	0 – 5.00 V	N/A
	AFC 2 LEVEL	0 - 5.00 V	N/A
	CODE VERSION	x.x	N/A
	PLL 1 CIRCUIT	LOCKED	FAULT
	PLL 2 CIRCUIT	LOCKED	FAULT
	AGC 1 LEVEL	0 - 5.00 V	N/A
	AGC 2 LEVEL	0 - 5.00 V	N/A
	INT. 10 MHz	IS USED	N/A
System Control Details	SUPPLY ENABLED FOR	xxx HOURS	N/A
Driver and PA Details	POWER SUPPLY STATE, 32V	32 VDC	N/A
	±12V SUPPLY	OK or OFF	FAULT
	FORWARD POWER	xxx%	xxx%
	REFLECTED POWER	xxx%	xxx%
	AMP 1 CURRENT	xx.xA	xx.xA
	AMP 2 CURRENT	xx.xA	xx.xA
	TEMPERATURE	xxC	xxC
	CODE VERSION	x.x	N/A
PA HAS OPERATED FOR	xxx HOURS	N/A	
Ext. Power Amplifier Modules Details (Only in high power systems). Will indicate Amp Set and Module within the Set. Will step through each Set and Module.	POWER SUPPLY VOLTAGE, 32V	31 – 32 VDC	N/A
	32V SUPPLY	ENABLED or DISABLED	FAULT
	FORWARD POWER	xxx%	xxx%
	REFLECTED POWER	xxx%	xxx%
	AMP CURRENT 1	xx.xA	xx.xA
	AMP CURRENT 2	xx.xA	xx.xA
	AMP CURRENT 3	xx.xA	xx.xA
	AMP TEMPERATURE	xxC	xxC
CODE VERSION	x.x	N/A	
PA HAS OPERATED FOR	xxx HOURS	N/A	

Pushing the ↓ Down Arrow, after scrolling through all the detail screens, will put you back to Menu 30, Table 3-21. Push the ESC button to exit the Transmitter Device Parameter Screens to Menu 12, Table 3-18 to the Transmitter Device Parameter Access Screen.

Menu 40 (Table 3-24) is entered by selecting ENT at Menu 13.

Table 3-24: Menu 40 - Authorized Personnel Screen

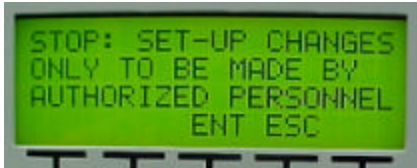

This screen of the transmitter notifies an operator that they are only to proceed if they are authorized to make changes to the transmitter's operation. Changes made within the

following set-up screens can affect the transmitters output power level, output frequency, and the general behavior of the transmitter. Please do not make changes within the transmitter's set-up screens unless you are familiar with the operation of the transmitter. This screen is implemented in transmitter software version 1.4 and above.

Pressing ENT will put you into the Transmitter Set Up Screens for Menu 40.

A safeguard is added to the Set Up Menus in software version 2.5 and above. If a change is made to a screen within the Set Up Menus, when you go to the next menu, a new screen asks if you accept the change or want to return to the previous menu to reconsider the changes made.

To accept the changes, the two buttons located under ACCEPT must be pushed simultaneously.

To return to the previous Menu to make corrections, the two buttons located under the RETURN must be pushed simultaneously.

Upon returning to the previous Menu the correct input must be entered and the above procedure repeated, this time accepting the changes

Accept or Return to previous Menu Screen



Pushing these two buttons Simultaneously will accept the change.

Pushing these two buttons Simultaneously will return you to the previous Menu.

The Set Up Screens are shown in Table 3-25 Menu 40-1 through Table 3-42 Menu 40-18 that follow.

Table 3-25: Menu 40-1 - Transmitter Set-up: Power Control Screen



This screen of the transmitter is the first of several that allows access to transmitter set-up parameters. This is the output Power Control Screen. When + is selected, the Power will increase. When - is selected, the Power will decrease.

Table 3-26: Menu 40-2 - Transmitter Set-up: Model Select Screen



This screen is used to specify which components are expected to be part of the system. By specifying the model number, the transmitter control firmware knows which components should be installed and it will be able to display faults for components that are not properly responding to system commands.

Table 3-27: Menu 40-3 - Transmitter Set-up: Receiver Channel Configuration



This screen of the transmitter allows access to transmitter frequency set-up parameters. The choices of this screen are as follow. **NOTE:** The above screen will only be present if a Receiver is part of the system. Used to set the Receiver Channel designation and for custom Channel Offsets the setting of the PLL operating frequency.

Table 3-28: Menu 40-4 - Transmitter Set-up: Upconverter Channel Select Screen



The choices of this screen are to the standard UHF / VHF channels. The + and – buttons change the desired channel of the transmitter. The PLL frequency is set for custom Offsets within the upconverter frequency. Any change to the channel is immediately set to the LO / Upconverter Frequency Synthesizer PLL circuit.

Table 3-29: Menu 40-5 - Transmitter Set-up: Serial Address Screen



This screen allows the user to set the serial address of the transmitter. The default address is 5. This value and all other set-up parameters, are stored in non-volatile memory.

Table 3-30: Menu 40-6 - Transmitter Set-up: Station ID Screen



This screen allows the user to set the Station ID, Call Sign, in analog transmitters. If blank characters are used for all five positions, then the Station ID feature is disabled. Otherwise the Station ID code is transmitted every 15 minutes. This value and all other set-up parameters, are stored in non-volatile memory. (**NOTE:** If an external Receiver Tray is used in your system, the LX Series Station ID is disabled. Therefore, the Station ID must be set up in the external Receiver Tray.)

Table 3-31: Menu 40-7 - Transmitter Set-up: System Visual Power Calibration



This screen is used to adjust the calibration of the system's visual power. A symbol placed under the '6' character is used to show major changes in the calibration value. When the calibration value is at full value, the character will be full black. As the value decreases, the character pixels are gradually turned off. The calibration value is a value between 0 and 255 but the calibration value symbol only has 40 pixels. Therefore small changes in actual calibration value may not affect the symbol's appearance.

Table 3-32: Menu 40-8 - Transmitter Set-up: System Aural Power Calibration



This screen is used to adjust the calibration of the system's aural forward power. A calibration value symbol is used for this screen as on the previous screen.

Table 3-33: Menu 40-9 - Transmitter Set-up: System Reflected Power Calibration

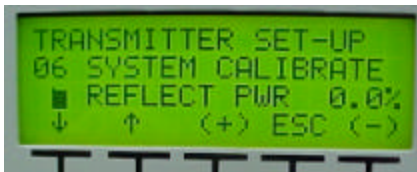

This screen is used to adjust the calibration of the system's reflected power. Again a calibration value symbol is used for this screen as on the previous screens.

Table 3-34: Menu 40-10 - Transmitter Set-up: Modulated Output Calibration



In analog systems this screen is used to adjust the calibration of the system's modulated output signal detector. The calibration value symbol is again used to graphically represent the modulated output signal detector's calibration value.

Table 3-35: Menu 40-11 - Transmitter Set-up: Aural Deviation Calibration



In analog systems this screen is used to adjust the calibration of the system's aural deviation detector. The calibration value symbol is again used to graphically represent the aural deviation detector's calibration value.

Table 3-36: Menu 40-12 - Transmitter Set-up: Forward Power Fault Threshold Screen

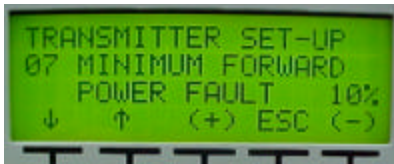

This screen is used to set the minimum forward power fault threshold. When the transmitter is operating, it must operate above this value otherwise the system will shut down with fault for 5 minutes. If after five minutes the fault is not fixed, the transmitter will enable, measure power less than this value and again shut down for five minutes.

Table 3-37: Menu 40-13 - Transmitter Set-up: Reflected Power Fault Threshold



This screen is used to set the maximum reflected power fault threshold. When the transmitter is operating, it must not operate above this value otherwise the system will slowly begin to reduce the forward output power. If the system's reflected output power exceeds the maximum reflected power threshold by five percent or more, the transmitter will shut down with fault for 5 minutes. If after five minutes the fault is not fixed, the transmitter will enable, measure power above this value plus five percent and again shut down for five minutes. If the system's reflected output power exceeds the maximum reflected power threshold due to some condition like the formation of ice on an antenna, the transmitter reduces forward power to a level where the reflected power is less than this threshold. The transmitter will automatically increase its output power to normal operation when the cause of higher than normal reflected power is corrected.

Table 3-38: Menu 40-14 - Transmitter Set-up: Auto Stand-By Control



Certain LX transmitter locations are required to reduce to no output power on the loss of video input. When a LX transmitter is configured for Auto Stand-By On Modulation Loss, the transmitter will switch to stand-by, if a modulated input signal fault is detected by the IF Processor module that lasts for more than ten seconds. Once the modulated input signal fault is cleared, a transmitter in operate mode will return to normal operation. This feature is implemented in transmitter software version 1.4 and above.

Table 3-39: Menu 40-15 - Transmitter Set-up: Receiver ALC Fault Set Up



This screen is used to set up the level of the ALC at which the Receiver will fault. This feature is implemented in transmitter software version 2.0 and above. **NOTE:** The above screen will only be present if a Receiver is part of the system.

Table 3-40: Menu 40-16 - Transmitter Set-up: Inner Loop Gain Control



This screen is used to set up the Inner Loop Gain of the exciter/amplifier assembly. This feature is implemented in transmitter software version 2.0 and above.

Table 3-41: Menu 40-17 - Transmitter Set-up: Optional System Control



This screen is used to set up any optional system, including the addition of the optional Modulator in a translator system. This feature is implemented in transmitter software version 2.0 and above.

Table 3-42: Menu 40-18 - Transmitter Set-up: Remote Commands Control



This screen is used to allow or deny the use of remote control commands. When disabled, remote commands are not used. Remote commands are commands received either through the rear terminal blocks or through serial messages.

Push the ESC button to exit the Transmitter Set Up Screens to Menu 13, Table 3-19, the Transmitter Configuration Access Screen.

This completes the description of the menu screens for the LX Series exciter/amplifier chassis assembly.

3.5.5 Operation Procedure

If necessary, connect to the transmitter to the antenna. Check that the output is 100% and if needed adjust the ALC Gain adjust pot on the front panel of the IF Processor to attain 100%. The power raise / lower settings, in the menus, are only to be used for temporary reductions in power. The power set-back values do not directly correspond to the output power of the transmitter.

This completes the Installation, Set Up and Turn On of the Driver/Transmitter.

NOTE: In dual exciter systems, repeat the above procedure with Exciter B selected as the On Air exciter. The exciter switcher system must be in manual.

If a problem occurred during the setup and operation procedures, refer to Chapter 5, Detailed Alignment Procedures, of this manual for more information.

Chapter 4 Circuit Descriptions

4.0 (Optional) Exciter Switcher Tray, (110 VAC 1305727 or 220 VAC 1305715); Appendix B)

NOTE: Part of a dual exciter system.

4.0.1 Exciter Switcher Control Board (220 VAC 1305704 or 110 VAC 1305725; Appendix B)

The Exciter Switcher Control Boards for 220 VAC and 110 VAC are the same except for the location of the T1 transformer. Location T1-110 is used with 110VAC input and location T1-230 is used with 230VAC input. Refer to the schematic for the board 1305705 Page 3 of 4, located in Appendix B, for a visual representation of the wiring.

The Exciter Switcher Control Board monitors and controls both Exciters and controls automatic switching of the Exciters in case of malfunction in the On-Air Exciter using a coaxial relay. ICs on the board monitor the operating parameters of the Exciters and determine if the Exciters are functioning properly. The front panel of the Exciter Switcher has an LCD display, which provides set up screens for the operation of the switching process.

The coaxial relay has four "N" connectors that provide input and output connections to the relay. The RF Output from Exciter "A" connects to J21. The RF Output from Exciter "B" connects to J23. The Selected Exciter RF Output to the external amplifiers connects to J24. The Exciter "A/B" Load connects to J22, to which the RF output of the Off Air Exciter is connected. An internal wire harness connects the relay to J14 on the Exciter Switcher Control Board. These connections provide the control voltages to the relay from the control board and status indication connections back to the control board.

4.1 (Optional) (A1) Receiver Module (VHF LB 1304000, VHF HB 1304001 or UHF 1304002; Appendix B)

NOTE: Not present in a transmitter system.

4.1.1 IF ALC Board (1304003; Appendix B) Used in the VHF LB 1304000, VHF HB 1304001 and UHF 1304002 Receiver Assemblies

The board provides the interface between the receiver and the backplane and also contains the control and ALC circuits for the sled.

The control portion of the board consists of a microcontroller (U8) and its associated components that communicate to the outside world via an RS-485 serial data link. The microcontroller receives various metering and alarm functions such as AFC and ALC voltages, PLL and ALC faults and communicates them back to the system controller for display on the transmitter's LCD display. It also receives the channel information from the system controller, and converts it to the programming data for the PLL chip on the Mixer/PLL Board in the receiver.

The IF portion of the board consists of an input pin attenuator, which is used to normalize the gain of the board to account for variations in the input level to the board. The pin attenuator consists of DS1, DS2 and associated components. The signal is then amplified by U2-U4 and associated components and applied to a SAW filter that rejects any out of channel signal that made it through the receivers RF front end. Amplifiers U5, U6 and their associated components are used to amplify the signal to make up for the loss through the filter. The final output of U6 is split by a lumped element Wilkinson splitter consisting of C21, C26, C27, L12, and L14. The output from one of the output ports is sent to the output of the

receiver, and the other output is connected to a peak detector and used by the ALC. The ALC circuit, consisting of U1, CR4 and its associated components, varies the gain of the pin attenuator on the front end of the board to maintain a constant output level. The pin attenuator has an overall adjustment range of approximately 50 dB.

There is a comparator that looks at the pin attenuator voltage and generates an alarm if the pin attenuator is close to running out of range. This alarm is likely to occur if the RF input signal to the receiver is weak or missing. This alarm is received by the microcontroller that passes it along to the transmitter's system controller, which mutes the signal in the IF processor until the fault goes away.

4.1.2 UHF Mixer/PLL Board (1304021; Appendix B) Used in the UHF 1304002 Receiver Assembly

OR VHF Mixer/PLL Board (1304013; Appendix B) Used in the VHF LB 1304000 and VHF HB 1304001 Receiver Assemblies

Both the VHF and UHF Mixer/PLL Boards operate the same except for where indicated in the description. This board converts the RF input to the receiver to a 44 MHz IF. It consists of a Mixer, a local oscillator and some IF amplifiers used to make up for the loss of the mixer.

The Local oscillator signal is generated by the VCO (U3), which operates directly at the LO frequency of the channel center frequency (400-800 MHz UHF or (104-176 MHz VHF) + 44 MHz. The oscillator is phase locked to a 10 MHz standard by U2, U8, and their associated components. TP1 shows the AFC voltage, which is also sent back to the IF ALC board to be displayed on the system level controller. The variable resistor R30 sets the LO output level to +10 dBm into the mixer U4. This is done by

looking at the LO sample at J2 with a spectrum analyzer, adjusting R30 until the level is -10 dBm. This ensures that the mixer gets the correct level, as the sample is 20 dB down from the level into the mixer.

Mixer U4 converts the RF input at J1 to an IF frequency of 44 MHz. L13, L14 and C56 form a low pass filter, which rejects any unwanted higher frequency conversion products. U5 and U9 amplify the signal, which exits the board at J5. There are two jumpers on J3 and J4 that allow the user to switch in a 10 dB attenuator if the input level to the receiver is too high. Normally the jumpers are connected between pins 1 and 2 of each connector, but if the user has a high input level, they can be switched to connect pins 2 and 3 of each connector, which switches in the 10 dB pad.

The A/V ratio of the incoming signal can be adjusted via an external front panel pot, which controls the bias on pin attenuator DS3. The pin attenuator controls the Q of a notch set at the aural IF carrier frequency, set by C41 and L7. The A/V ratio control is used if the incoming signal has an aural carrier that is too high relative to the visual carrier.

4.1.3 UHF Preamplifier Board (1304092; Appendix B) Used in the UHF 1304002 Receiver Assembly

OR VHF Low Band Preamplifier Board (1305213; Appendix B) Used in the VHF LB 1304000 Receiver Assembly

OR VHF High Band Preamplifier Board (1303878; Appendix B) Used in the VHF HB 1304001 Receiver Assembly

The VHF Low Band, VHF High Band and UHF Preamplifier Boards operate the same except for where indicated in the description.

This board filters and amplifies the low level RF input signal to the receiver. It consists of two two-pole bandpass filters

and a dual stage preamplifier. The filters are tuned at the RF channel frequency and are about 8 MHz wide. They are intended to filter off the unwanted image product 88 MHz below the Channel center frequency. Each filter is a combination micro-strip lumped element filter. The center frequency of the filter is set by C10 and C11 for the input filter and C20 and C21 for the output filter on the UHF preamplifier. The center frequency of the filter is set by C6, C8 and C10 for the input filter, and C26, C28 and C30 for the output filter on the VHF LB preamplifier. The VHF HB has no adjustments for the input and output filters.

The input filter also has provisions to insert a +12V DC signal onto the center conductor of the receiver's RF input to power an external preamp. The jumper W1 on J2 controls whether or not the DC bias is applied to the center conductor. When it is connected between pins 1 and 2, the +12V bias is applied. When it is between pins 2 and 3, there is no bias applied. The presence of the DC bias is displayed on a front panel LED on the sled.

CAUTION: Do not hook up the RF input to any test equipment with the DC bias applied. Always move the jumper W1 on J2 to the Bias off position, between pins 2 & 3, to prevent possible damage to the test equipment.

The amplifier consists of two cascaded stages, which provide approximately 27 dB of gain across the VHF LB, VHF HB or UHF band.

4.2 (A2) Modulator Module (1301929; Appendix B)

NOTE: May not be present in a translator system.

4.2.1 Analog Modulator Board (1301797; Appendix B)

The board takes the audio and video inputs and produces a modulated visual IF + aural IF output.

Main Audio and Aural IF portion of the board

The analog modulator board takes each of the three possible audio inputs and provides a single audio output.

4.2.1.1 MONO, Balanced Audio Input

The first of the three possible baseband inputs to the board is a 600 Ω , balanced-audio input (0 to +10 dBm) that enters through jack J41A, pins 10A (+), 12A (GND), and 11A (-), and is buffered by U11A and U11B. Diodes CR9, CR10, CR12 and CR13 protect the input to U11A and U11B if an excessive signal level is present on the input. The outputs of U11A and U11B are applied to differential amplifier U11C. U11C eliminates any common mode signals (hum) on its input leads. A pre-emphasis of 75 μ s is provided by R97, C44, and R98 and can be eliminated by removing jumper W6 on J22. The signal is then applied to amplifier U11D whose gain is controlled by jumper W7 on J23. Jumper W7 on jack J23 is positioned according to the input level of the audio signal (0 or +10 dBm). If the input level is approximately 0 dBm, the mini-jumper should be in the high gain position between pins 1 and 2 of jack J23. If the input level is approximately +10 dBm, the mini-jumper should be in low gain position between pins 2 and 3 of jack J23. The balanced audio is then connected to buffer amplifier U12A whose input level is determined by the setting of the MONO, balanced audio gain pot R110, accessed through the front panel. The output of the amplifier stage is wired to the summing point at U13C, pin 9.

4.2.1.2 STEREO, Composite Audio Input

The second possible audio input to the board is the composite audio (stereo) input

that connects to the board at J41A Pin 14A (+) and J41A Pin 13A (-).

NOTE: For the transmitter to operate using the composite audio input the Jumper W1 on J4 must be between Pins 2 and 3, the Jumper W2 on J6 must be between Pins 2 and 3 and the Jumper W4 on J5 must be between Pins 1 and 2. These jumpers connect the composite audio to the rest of the board.

Jumper W14 on jack J26 provides a 75 Ω input impedance when the jumper is between pins 1 and 2 and a high impedance when it is between pins 2 and 3. The Diodes CR17, CR18, CR20 and CR21 protect the input stages of U14A and U14B if an excessive signal level is applied to the board. The outputs of U14A and U14B are applied to the differential amplifier U13A, which eliminates common mode signals (hum) on its input leads. The composite input signal is then applied to the amplifier U13B, whose gain is controlled by the STEREO, composite audio gain pot R132, accessed through the front panel. The composite audio signal is then connected to the summing point at U13C, pin 9.

4.2.1.3 SAP/PRO, Subcarrier Audio Input

The third possible input to the board is the SAP/PRO, SCA audio input at J41A pin 16A(+) and 17A(-). The SCA input has an input matching impedance of 75 Ω that can be eliminated by removing the jumper W15 from pins 1 and 2 on J28. The SCA input is bandpass filtered by C73, C74, R145, C78, C79, and R146 and is fed to the buffer amplifier U13D. The amplified signal is then applied through the SAP/PRO, SCA gain pot R150, accessed through the front panel, to the summing point at pin 9 of U13C.

4.2.1.4 Audio Modulation of the 4.5 MHz VCO

The Mono balanced audio, or the Stereo composite audio, or the SAP/PRO SCA buffered audio signal, is fed to the

common junction of resistors R111, R130, and R152 that connect to pin 9 of amplifier U13C. The output audio signal at pin 8 of U13C is typically .8 Vpk-pk at a ± 25 kHz deviation for Mono balanced audio or .8 Vpk-pk at ± 75 kHz deviation for Stereo composite audio as measured at the Test Point TP1. This audio deviation signal is applied to the circuits containing the 4.5 MHz aural VCO U16. A sample of the aural deviation level is amplified, detected by U15A and U15B, and connected to J41A pin 5A on the board. This audio-deviation level is connected to the front panel LCD display on the Control/Power Supply Assembly.

The audio from U13C is connected through C71, a frequency response adjustment, to varactor diodes, CR24 to CR27, that frequency modulate the audio signal onto the generated 4.5 MHz signal. U16 is the 4.5 MHz VCO that generates the 4.5 MHz continuous wave (CW) signal. The output frequency of the 4.5 MHz signal is maintained and controlled by the correction voltage output of the U21 PLL integrated circuit (IC), at "N", that connects to the varactor diodes. The audio modulated, 4.5 MHz signal is fed through the emitter follower Q13 to the amplifiers U17A and U17B. The amplified output of U17A is connected to a 4.5 MHz filter and then to U17B. The output of U17B is connected to the 4.5 MHz output sample jack at J29 and through the Jumper W4 on J5 pins 1 & 2, "J", to the I input of the mixer Z1.

4.2.1.5 Phase Lock Loop (PLL) Circuit

A sample of the signal from the 4.5 MHz aural VCO at the output of Q13, "M", is applied to the PLL IC U21 at pin 1, the F_{in} connection. In U21, the signal is divided down to 50 kHz and is compared to a 50 kHz reference signal that is a divided-down sample of the 45.75 MHz visual IF signal. This 50 kHz sample is applied to the oscillator-in connection at Pin 27 on the PLL chip. These two 50 kHz signals are compared in the IC and the f_V , and f_R is applied to the differential amplifier U18A.

The output of U18A, "N", is fed back through CR28 and C85 to the 4.5 MHz VCO IC U16, which sets up a PLL circuit. The 4.5 MHz VCO will maintain the extremely accurate 4.5 MHz separation between the visual and aural IF signals. Any change in frequency will be corrected by the AFC error voltage.

The PLL chip U21 also contains an internal lock detector that indicates the status of the PLL circuit. When U21 is in a "locked" state, pin 28 is high. If the 4.5 MHz VCO and the 45.75 MHz oscillator become "unlocked," out of the capture range of the PLL circuit, pin 28 of U21 will go to a logic low and cause the LED DS5 to light red. The Aural Unlock LED is viewed through the front panel of the Assembly. An Aural unlock, PLL Unlocked, output signal from Q16 is also applied to jack J41B pin 1B.

Sync tip clamp and the visual and aural modulator portions of the board

The sync tip clamp and modulator portion of the board is made up of four circuits: the main video circuit, the sync tip clamp circuit, the visual modulator circuit and the aural modulator circuit.

The clamp portion of the board maintains a constant peak of sync level over varying average picture levels (APL). The modulator portion of the board contains the circuitry that generates an amplitude-modulated vestigial sideband visual IF signal output that is made up of the baseband video input signal (.5 to 1 Vpk-pk) modulated onto a 45.75 MHz IF carrier frequency. The visual IF signal and the aural IF signal are then combined in the diplexer circuit to produce the visual IF + aural IF output, "G", that is connected to J41C pin 28C the Combined IF output of the board.

4.2.1.6 Main Video Signal Path (Part 1 of 2)

The baseband video input connects to the board at J41A pins 19A (-), "W", and 20A (+), "V". The +, "V" and -, "W", video inputs are fed to Diodes CR1 to CR4 that form a voltage-limiter network in which, if the input voltages exceed the supply voltages for U2B, the diodes conduct, preventing damage to U2B. CR1 and CR3 conduct if the input voltage exceeds the negative supply and CR2 and CR4 conduct if the input voltage exceeds the positive supply voltage. The baseband video input connects to the non-inverting and inverting inputs of U2B, a differential amplifier that minimizes any common-mode problems that may be present on the incoming signal

The video output of U2B is connected through the Video Gain pot R42, accessed through the front panel, to the amplifier U2A. The output of U2A connects to the delay equalizer circuits

4.2.1.7 Delay Equalizer Circuits

The delay equalizer circuits provide a delay to the video signal, correction to the frequency response, and amplification of the video signal.

The video output of U2A is wired to the first of four delay-equalizing circuits that shape the video signal to the FCC specification for delay equalization or to the shape needed for the system. The board has been factory-adjusted to this FCC specification and should not be readjusted without the proper equipment.

Resistors R53, R63, R61, and R58 adjust the sharpness of the response curve while inductors GD1, GD2, GD3, and GD4 adjust the position of the curve. The group delayed video signal at the output of U3A is split with a sample connected to J8 on the board that can be used for testing purposes of the Post Video Delay signal. The other portion of the video signal connects through the Jumper W5 on J9 pins 2 and 3. The video is split with one part connecting to a sync tip clamp circuit and the other part to the main video output path through R44. A sample of the

video at "P" connects to U32 and U33 that provides a zero adjust and a 1 Volt output level, which connects at "T" to J41A pin 3A. This video level is wired to the Control/Power Supply assembly.

4.2.1.8 Sync Tip Clamp Circuit

The automatic sync tip clamp circuit is made up of U6A, Q8, U5C, and associated components. The circuit begins with a sample of the clamped video that is buffered by U3A, and is split off from the main video path that connects to U6A. The level at which the tip of sync is clamped is -1.04 VDC as set by the voltage-divider network, R77, R78, R75, R76 and R80 connected to U6A. If the video level changes, the sample applied to U6A changes. The voltage from the clamp circuit that is applied to the summing circuit at the base of Q8 will change; this will bring the sync tip level back to -1.04 VDC. Q8 will be turned off and on according to the peak of sync voltage level that is applied to U6A. The capacitors C35 and C24, in the output circuit of Q8, will charge or discharge to the new voltage level. This will bias U5C more or less, through the front panel MANUAL/AUTO CLAMP switch, SW1, when it is in the Auto Clamp-On position, between pins 2 and 3. In AUTO CLAMP, U5C will increase or decrease its output, as needed, to bring the peak of sync back to the correct level. The voltage level is applied through U5C to U2A. In the Manual CLAMP position, SW1 in manual position, between pins 1 and 2, the adjustable resistor R67 provides the manual clamp bias adjustment for the video that connects to U5C. This level is set at the factory and is not adjustable by the customer. In Manual clamp the peak of sync auto clamp circuit will not automatically be clamped to the pre set level.

4.2.1.9 Main Video Signal Path (Part 2 of 2)

A sample of the clamped video output from the group delay circuitry at the

junction of R44, R62 and R300 is connected to a white clipper circuit consisting of Q1 and associated circuitry. The base voltage of Q1 is set by the voltage divider network consisting of R1, R9 and R5. R5 is variable and sets the level of the white clipper circuit to prevent video transients from over modulating the video carrier.

The clamped video output of amplifier U3A is split with one part connected through R35 to J8 that provides a sample of the Post Video Delay Signal.

The other clamped video path from U3A is through the jumper W5 on J9 pins 2 & 3 through R44 to a sync-stretch circuit that consists of Q3 and Q4. The sync-stretch circuit contains R19, which adjusts the Sync Stretch Magnitude (amount), R11, which adjusts the Sync Stretch Cut-In and R6, which adjusts the Sync Clipping point. This sync-stretch adjustment should not be used to correct for output sync problems, but it can be used for input video sync problems. The output of the sync-stretch circuit is amplified by U31A and connected, "K", to pin 5, the I input of Mixer Z2, the Visual IF Mixer.

4.2.1.10 45.75 MHz Oven Oscillator Circuit

The oven oscillator portion of the board generates the visual IF CW signal at 45.75 MHz for NTSC system "M" usage.

The +12 VDC needed to operate the oven is applied through jack J30 pin 1 on the crystal oven HR1. The oven is preset to operate at 60° C. The oven encloses the 45.75 MHz crystal Y1 and stabilizes the crystal temperature. The crystal is the principal device that determines the operating frequency and is the most sensitive in terms of temperature stability.

Crystal Y1 operates in an oscillator circuit consisting of transistor Q24 and its associated components. Feedback that is provided by a voltage divider, consisting of C173, L38 and R295, is fed to the base of

Q24 through C169. This circuitry operates the crystal in a common-base amplifier configuration using Q24. The operating frequency of the oscillator is maintained by a PLL circuit, which consists of ICs U20 and U22 and associated components, whose PLL output connects to R293 in the crystal circuit.

The oscillator circuit around Q24 has a regulated voltage, +6.8 VDC, which is produced from the +12 VDC by a combination of dropping resistor R261, diodes CR37 and CR38 and Zener diode VR2. The output of the oscillator at the collector of Q24 is capacitively coupled through C165 to the base of Q23. The small value of C165, 15 pF, keeps the oscillator from being loaded down by Q23. Q23 is operated as a common-emitter amplifier stage whose bias is provided through R259 from the +12 VDC line. The output of Q23, at its collector, is connected to an emitter-follower transistor stage, Q21. The output of Q21 at its emitter is split. One path connects to the input of the IC U20 in the PLL circuit. The other path is through R270 to establish an approximate 500 source impedance through C166 to the Pin 1 contact of the relay K2. The 45.75 MHz connects through the closed contacts of K2 to a splitter network consisting of L31 and L32.

NOTE: The relay contacts for the internally generated 45.75 MHz signal will be closed unless an external IF signal, such as the IF for offset and precise frequency 45.74 or 45.76 MHz, connects to the board.

The external IF CW Input connects at J41A pin 32A and is connected to J19 and through the external cable assembly W10 back to the board at J20. The external IF CW input is split on the board. One branch connects through C157 to a buffer amplifier Q20 to the K2 relay at pin 14. The other path is through C152 to the amplifier U23A. The output of

U23A is split with one part connecting to Q26 that shuts down the 45.75 MHz oscillator. Another path connects to Q25 the conducts and lights the LED DS7, Alternate IF, viewed on the front panel. The final path connects through R268 to Q22 that is biased on and energizes the relay, K2. The external IF CW Input at contact 14 now connects through the closed contact to the splitter network consisting of L31 and L32.

Either the internal or external CW IF from the K2 relay is split with one path through L31 to the amplifier U28 to the L input of Z1 the Aural IF Mixer. The other path is through L32 to the amplifier U29 to the L input of Z2 the Visual IF Mixer.

4.2.1.11 Visual Modulator Circuit

The video signal is heterodyned in mixer Z2 with the visual IF CW signal (45.75 MHz). The visual IF CW signal from L32 of the splitter connects to U29, where it is amplified and wired to pin 1, the L input of mixer Z2. Adjustable capacitor C168 and resistor R275 are set up to add a small amount of incidental carrier phase modulation (ICPM) correction to the output of the mixer stage to compensate for any non-linearities generated by the mixer.

The modulated 45.75 MHz RF output of mixer Z2, at pin 4 the R output, is amplified by U30 and is fed to J17 through W8, the external cable assembly, "WB", to J13 on the board. J17 is the visual IF loop-through output jack that is normally jumpered to J13 on the board. The modulated visual IF through J13 connects to J41C pin 17C the Visual IF Output of the board.

4.2.1.12 Aural Modulator Circuit

The mixer Z1 heterodynes the aural-modulated 4.5 MHz signal with the 45.75 MHz IF CW signal to produce the modulated 41.25-MHz aural IF signal. The audio modulated 4.5 MHz from the 4.5 MHz VCO IC U16 connects, "J", to the I input at pin 5 of Z1. The visual IF CW

signal from L31 of the splitter connects to U28, where it is amplified and wired to pin 1, the L input of mixer Z1. The R output of the mixer at pin 4 is fed to a bandpass filter, consisting of L18-L21, L25-L28 and C136, C137 and C142-144, that is tuned to pass only the modulated 41.25-MHz aural IF signal. The filtered 41.25 MHz is fed to the amplifier U27. The amplified 41.25 MHz signal is connected by a coaxial cable, W9, from J21, "WC", to J18 on the board. The modulated 41.25 MHz aural IF signal from J18 is connected to J41C pin 6C, the Aural IF Output of the board.

4.2.1.13 Combining the 45.75 MHz Visual IF and 41.25 MHz Aural IF Signals

The Visual IF connects back to the board at J41C pin 3C, through a Visual IF jumper cable connected to the rear chassis of the exciter/driver. IF processing equipment can be connected in place of the jumper if needed. The visual IF is connected to J12, through jumper W7, "WA", to J14. The visual IF is amplified by U24 and filtered by FL1 with T1 and T2 providing isolation. The filtered IF is amplified by U25 and adjusted in level by R214 before it is connected to a summing circuit at the common connection of L16 and L17.

The Aural IF connects back to the board at J41C pin 23C, through an Aural IF jumper cable connected to the rear chassis of the exciter/driver. IF processing equipment can be connected in place of the jumper if needed. The aural IF, "F", is connected through C132, R234, R235 and adjusted in level by R243 before it is connected to a summing circuit at the common connection of L17 and L16.

The Aural IF and Visual IF signals are combined through L16 and L17. The frequency response of the combined 41.25 MHz + 45.75 MHz signal is set by R238 and R239 and associated components. The corrected combined IF signal is amplified by U25 and connected

to a splitter matching network consisting of T3 and T4. One part of signal connects to J10, the 41.25 MHz + 45.75 MHz sample output jack, located on the front panel. The other part, "G", connects to J41C pin 28C the Combined IF Output of the board.

4.2.1.14 Voltage Requirements

The ± 12 VDC needed for the operation of the board enters through jack J41A pins 25A (+12 VDC) and 26A (-12 VDC). The +12 VDC is filtered by L6, L7, and C27 before it is connected to the rest of the board. The +12 VDC also connects to U7, a 5-volt regulator IC, that provides +5 VDC to the rest of the board.

The -12 VDC is filtered by L5, C16, and C17 before it is connected to the rest of the board.

4.3 (A3) IF Processor Module Assembly (1301938; Appendix B)

The IF from the modulator enters the module and the signal is pre-corrected as needed for amplitude linearity correction, Incidental Carrier Phase Modulation (ICPM) correction and frequency response correction.

The Module contains the IF Processor board.

4.3.1 IF Processor Board (1301977; Appendix B)

The automatic level control (ALC) portion of the board provides the ALC and amplitude linearity correction of the IF signal. The ALC adjusts the level of the IF signal that controls the output power of the transmitter.

The IF from the modulator enters the board at J42 pin 32B. If the (optional) receiver is present, the IF input (-6 dBm) from the receiver connects to the modulated IF input jack J42 Pin 21C. The modulator IF input connects to relay K3

and the receiver IF input connects to relay K4.

The Modulator select enable/disable jumper W11 on J29 controls whether the Modulator Select command at J42 Pin 14C controls the operation of the relays. With the jumper W11 on J29 between pins 1 and 2, the external Modulator Select command at J42 Pin 14C controls the operation of the relays. With the jumper W11 on J29 between pins 2 and 3, the Modulator input is selected all of the time.

4.3.1.1 Modulator Selected

With the modulator selected, J42-14C low or the jumper W11 on J29 between pins 2 and 3, the low shuts off Q12 and causes Pin 8 on the relays to go high that causes relays K3 and K4 to de-energize. When K4 is de-energized, it connects the receiver IF input at J42-21C, if present, to a 500 load. When K3 is de-energized, it connects the modulator IF input at J42-32B to the rest of the board and the Modulator Enable LED DS5 will be illuminated.

4.3.1.2 External Modulated IF Selected

With the External Modulated IF selected, J42-14C high and jumper W11 on J29 between pins 1 and 2, this high turns on Q12 and makes pin 8 on the relays Low that causes the relays K3 and K4 to energize. When K4 is energized, it connects the receiver IF input at J42-21C, if present, to the rest of the board. When K3 is energized, it connects the modulator IF input at J42-32B to a 500 load and the Modulator Enable LED DS5 will not be illuminated.

4.3.1.3 Main IF Signal Path (Part 1 of 3)

The selected IF input (-6 dBm average) signal is split, with one half entering a bandpass filter that consists of L3, L4, C4, L5, and L6. This bandpass filter can be tuned with C4 and is substantially broader than the IF signal bandwidth. It

is used to slightly steer the frequency response of the IF to make up for any small discrepancies in the frequency response in the stages that precede this point. The filter also serves the additional function of rejecting unwanted frequencies that may occur if the tray cover is off and the tray is in a high RF environment. (If this is the case, the transmitter will have to be serviced with the tray cover off in spite of the presence of other RF signals). The filtered IF signal is fed through a pi-type matching pad consisting of R2, R3, and R4 to the pin-diode attenuator circuit consisting of CR1, CR2, and CR3.

4.3.1.4 Input Level Detector Circuit

The other part of the split IF input is connected through L2 and C44 to U7. U7 is an IC amplifier that is the input to the input level detector circuit. The amplified IF is fed to T4, which is a step-up transformer that feeds diode detector CR14. The positive-going detected signal is then low-pass filtered by C49, L18, and C50. This allows only the positive digital peaks to be applied through emitter follower Q1. The signal is then connected to detector CR15 to produce a peak digital voltage that is applied to op-amp U9A. There is a test point at TP3 that provides a voltage-reference check of the input level. The detector serves the dual function of providing a reference that determines the input IF signal level to the board and also serves as an input threshold detector.

The input threshold detector prevents the automatic level control from reducing the attenuation of the pin-diode attenuator to minimum, the maximum signal output, if the IF input to the board is removed. The ALC, input loss cutback, and the threshold detector circuits will only operate when jumper W2 on jack J5 is in the Enabled position, between pins 2 and 3. Without the threshold detector, and with the pin-diode attenuator at minimum, the signal will overdrive the stages following this board when the input is restored.

As part of the threshold detector operation, the minimum IF input level at TP3 is fed through detector CR15 to op-amp IC U9A, pin 2. The reference voltage for the op-amp is determined by the voltage divider that consists of R50 and R51, off the +12 VDC line. When the detected input signal level at U9A, pin 2, falls below this reference threshold, approximately 10 dB below the normal input level, the output of U9A at pin 1 goes high, toward the +12 VDC rail. This high is connected to the base of Q2 that is forward biased and creates a current path. This path runs from the -12 VDC line, through red LED DS1, the input level fault indicator, which lights, resistor R54, and transistor Q2 to +12 VDC. The high from U9A also connects through diode CR16 and R52, to U24D pin 12, whose output at pin 14 goes high. The high connects through the front panel accessible ALC Gain pot R284 and the full power set pot R252 to U24C Pin 9. This high causes U24C pin 8 to go low. A power raise/lower input from the Control/Monitoring Module connects to J42C pin 24C and is wired to Q14. This input will increase or decrease the value of the low applied to U24B and therefore increase or decrease the power output of the transmitter.

The low connects to U24B pin 5 whose output goes low. The low is wired to U24A pin 2 whose output goes high. The high is applied to U10A, pin 2, whose output goes low. The low connects through the switch SW1, if it is in the auto gain position, to the pin-diode attenuator circuit, CR1, CR2 & CR3. The low reverse biases them and cuts back the IF level, therefore the output level, to 0. When the input signal level increases above the threshold level, the output power will increase, as the input level increases, until normal output power is reached.

The input level at TP3 is also fed to a pulse detector circuit, consisting of IC U8, CR17, Q3, and associated components, and then to a comparator circuit made up

of U9C and U9D. The reference voltage for the comparators is determined by a voltage divider consisting of R243, R65, R66, and R130, off the -12 VDC line. When the input signal level to the detector at TP3 falls below this reference threshold, which acts as a loss-of-signal peak detector circuit, the output of U9C and U9D goes towards the -12 VDC rail and is split, with one part biasing on transistor Q5. A current path is then established from the +12 VDC line through Q5, the resistors R69 and R137, and the red LED DS3, input loss indicator, which is illuminated. When Q5 is on, it applies a high to the gate of Q6. This causes it to conduct and apply a modulation loss pull-down output to J42C, pin 7C, which is applied to the front panel display on the Control/Monitor module.

The other low output of U9C and U9D is connected through CR18, CR19 & CR20 to jack J5. Jumper W2 on J5, in the Cutback Enable position, which is between pins 2 and 3, connects the low to the base of Q4 that is now forward-biased. **NOTE:** If jumper W2 is in the Disable position, between pins 1 and 2, the auto cutback will not operate. With Q4 biased on, a negative level determined by the setting of cutback level pot R71 is applied to U24D, pin 12. The level is set at the factory to cut back the output to approximately 25%. The output of U24D at pin 14 goes low and is applied through the power adjust pot to U24C, pin 9, whose output goes low. The low connects to U24B, pin 5, whose output goes low. The low then connects to U24A, pin 2, whose output goes high. The high is applied to U10A, pin 2, whose output goes low. The low connects through the switch SW1, if it is in the auto gain position, to the pin-diode attenuator circuit, CR1, CR2 & CR3. The low reverse biases them and cuts back the level of the output to approximately 25%.

4.3.1.5 Pin-Diode Attenuator Circuit

The input IF signal is fed to a pin-diode attenuator circuit that consists of CR1, CR2 & CR3. Each of the pin diodes contains a wide intrinsic region; this makes the diodes

function as voltage-variable resistors at this intermediate frequency. The value of the resistance is controlled by the DC bias supplied to the diode. The pin diodes are configured in a pi-type attenuator configuration where CR1 is the first shunt element, CR3 is the series element, and CR2 is the second shunt element. The control voltage, which can be measured at TP1, originates either from the ALC circuit when the switch SW1 is in the ALC Auto position, between pins 2 and 3, or from pot R87 when SW1 is in the Manual Gain position, between pins 1 and 2.

In the pin diode attenuator circuit, changing the amount of current through the diodes by forward biasing them changes the IF output level of the board. There are two extremes of attenuation ranges for the pin-diode attenuators. In the minimum attenuation case, the voltage, measured at TP1, approaches the +12 VDC line. There is a current path created through R6, through series diode CR3, and finally through R9 to ground. This path forward biases CR3 and causes it to act as a relatively low-value resistor. In addition, the larger current flow increases the voltage drop across R9 that tends to turn off diodes CR1 and CR2 and causes them to act as high-value resistors. In this case, the shunt elements act as a high resistance and the series element acts as a low resistance to represent the minimum loss condition of the attenuator (maximum signal output). The other extreme case occurs as the voltage at TP1 is reduced and goes towards ground or even slightly negative. This tends to turn off (reverse bias) diode CR3, the series element, causing it to act as a high-value resistor. An existing fixed current path from the +12 VDC line, and through R5, CR1, CR2, and R9, biases series element CR3 off and shunt elements, diodes CR1 and CR2, on, causing them to act as relatively low-value resistors. This represents the maximum attenuation case of the pin attenuator (minimum signal output). By controlling the value of the voltage

applied to the pin diodes, the IF signal level is maintained at the set level.

4.3.1.6 Main IF Signal Path (Part 2 of 3)

When the IF signal passes out of the pin-diode attenuator through C11, it is applied to the modular amplifier U1. This device contains the biasing and impedance-matching circuits that makes it operate as a wide-band IF amplifier. The output of U1 connects to J40 that is jumpered to J41. The J40 jack is available, as a sample of the pre-correction IF for troubleshooting purposes and system setup. The IF signal is connected to a splitter Z1 that has an In Phase output and a 90° Quadrature output, which are then connected to the linearity corrector portion of the board.

4.3.1.7 Amplitude and Phase Pre-Correction Circuits

The linearity corrector circuits use three stages of correction, two adjust for any amplitude non-linearities and one for phase non-linearities of the output signal. Two of the stages are in the In Phase Amplitude pre-correction path and one stage is in the Quadrature Phase pre-correction path. Each stage has a variable threshold control adjustment, R211 and R216, in the In Phase path, and R231, in the Quadrature path, that determines the point at which the gain is changed for that stage. Two reference voltages are needed for the operation of the corrector circuits. The Zener diode VR3, through R261, provides the +6.8 VDC reference. The VREF is produced using the path through R265 and the diodes CR30 and CR31. They provide a .9 VDC reference, which temperature compensates for the two diodes in each corrector stage.

The first corrector stage in the In Phase path operates as follows. The In Phase IF signal is applied to transformer T6, which doubles the voltage swing by means of a 1:4 impedance transformation. Resistors R222 and R225 form an L-pad that lowers the level of the signal. The input signal level, when it reaches a set level, causes

the diodes CR24 and CR25 to turn on, generating current flow that puts them in parallel with the L-pad. When the diodes are put in parallel with the resistors, the attenuation through the L-pad is lowered, causing signal stretch.

The signal is next applied to amplifier U17 to compensate for the loss through the L-pad. The breakpoint, or cut-in point, for the first corrector is set by controlling where CR24 and CR25 turn on. This is accomplished by adjusting the threshold cut-in resistor R211. R211 forms a voltage-divider network from +6.8 VDC to ground. The voltage at the wiper arm of R211 is buffered by the unity-gain amplifier U16B. This reference voltage is then applied to R215, R216, and C134 through L44 to the CR24 diode. C134 keeps the reference from sagging during the vertical interval. The .9 VDC reference voltage is applied to the unity-gain amplifier U16D. The reference voltage is then connected to diode CR25 through choke L45. The two chokes L44 and L45 form a high impedance for RF that serves to isolate the op-amp ICs from the IF.

After the signal is amplified by U17, it is applied to the second corrector stage in the In Phase path through T7. These two correctors and the third corrector stage in the Quadrature path operate in the same fashion as the first. All three corrector stages are independent and do not interact with each other.

The correctors can be disabled by moving the jumper W12 on J30 to the Disable position, between pins 1 and 2, this moves all of the breakpoints past the signal peaks so that they will have no affect.

The pre-distorted IF signal in the In Phase path, connects to an op amp U18 whose output level is controlled by R238. R238 provides a means of balancing the level of the amplitude pre-distorted IF signal that then connects to the combiner Z2.

The pre-distorted IF signal in the Quadrature path connects to op amp U20 and then step up transformer T9, next op amp U21 and step up transformer T10 and finally op amp U22 whose output level is controlled by R258. R258 provides a means of balancing the level of the Phase pre-distorted IF signal that then connects to the combiner Z2.

The Amplitude and Phase pre-distorted IF signals are combined by Z2 and connected to J37 that is jumpered to J36 on the board. J37 can be used for testing or monitoring purposes of the IF signal after Amplitude and Phase pre-distortion. The pre-distorted IF signal connects through a resistor buffer network that prevents loading of the combiner before it is wired to the frequency response circuitry.

4.3.1.8 Main IF Signal Path (Part 3 of 3)

The IF signal, at the input to the frequency-response corrector circuit, is split using L24, L25 and R89. One path is through L24, which is the main IF path through the board. The main IF is fed through a resistor network that controls the level of the IF by adjusting the resistance of R99, the output level adjust. The IF signal is then applied to a three-stage, frequency-response corrector circuit that is adjusted as needed.

The frequency-response corrector circuit operates as follows. Variable resistors R103, R106 and R274 are used to adjust the depth and gain of the notches and variable caps C71, C72 and C171 are used to adjust the frequency position of the notches. These are adjusted as needed to compensate for frequency response problems.

The frequency-response corrected IF is connected to J38 that is jumpered to J39 on the board. J38 can be used for testing or monitoring purposes of the IF signal after frequency response pre-correction.

The IF is next amplified by U13 and U14. After amplification, the IF is split with one path connected to J42C pin 1C the IF output to the LO/Upconverter Module. The other path is fed through a divider network to J35 a SMA IF Sample Jack, located on the front panel, which provides a sample of the corrected IF for test purposes.

4.3.1.9 ALC Circuit

The other path of the corrected IF signal at the input to the frequency response corrector circuit is used in the ALC circuit. The IF flows through L25, of the L24 L25 splitter, and connects to the op-amp U12. The IF signal is applied through a resistor divider network to transformer T5. T5 doubles the voltage swing by means of a 1:4 impedance transformation before it is connected to the ALC detector circuit, consisting of C70, CR23 and R91. The detected ALC level output is amplified by U10B and wired to U10A, pin 2, where it is summed with the power control setting, which is the output power setting that is maintained by the ALC. The output of U10A connects through SW1, if it is in the auto gain position, to the pin-diode attenuator circuit, CR1, CR2 & CR3. The high forward biases them more or less, that increases or decreases the IF level, therefore the output level, opposite the input level. When the input signal level increases, the forward bias on the pin attenuator decreases, therefore the output power will decrease, which keeps the output power the same as set by the customer.

An external power raise/lower switch can be used by connecting it to TB30, at TB30-8 power raise and TB30-9 power lower, on the rear of the exciter/amplifier chassis. The ALC voltage is set for .8 VDC at TP4 with a 0-dBm output at J42C pin 1C of the module. A sample of the ALC at J42C pin 11C, is wired to the Control Monitoring/Power Supply module where it is used on the LCD display and in the AGC circuits.

The ALC voltage, and the DC level corresponding to the IF level after signal correction, are fed to U10A, pin 2, whose output at pin 1 connects to the ALC pin-diode attenuator circuit. If there is a loss of gain somewhere in an IF circuit, the output power of the transmitter will drop. The ALC circuit senses this drop at U10A and automatically decreases the loss through the pin-diode attenuator circuit therefore increasing its gain maintaining the same output power level.

The ALC action starts with the ALC detector level monitored at TP4. The detector output at TP4 is nominally +.8 VDC and is applied through resistor R77 to a summing point at op-amp U10A, pin 2. The current available from the ALC detector is offset, or complemented, by current taken away from the summing junction. In normal operation, U10A, pin 2, is at 0 VDC when the loop is satisfied. If the recovered or peak-detected IF signal level at IF input to this board should drop, which normally means that the output power will decrease, the null condition would no longer occur at U10A, pin 2. When the level drops, the output of U10A, pin 1, will go more positive. If SW1 is in the Automatic position, it will cause the ALC pin-diode attenuators CR1, CR2, and CR3 to have less attenuation and increase the IF level; this will compensate for the decrease in the level. If the ALC cannot increase the input level enough to satisfy the ALC loop, due to the lack of range, an ALC fault will occur. The fault is generated because U10D, pin 12, increases above the trip point set by R84 and R83 until it conducts. This makes U10D, pin 14, high and causes the red ALC Fault LED DS2 to light.

4.3.1.10 Fault Command

The board also has circuitry for an external mute fault input at J42 pin 10C. This is a Mute command that protects the circuits of high-gain output amplifier devices against VSWR faults. This action needs to occur faster than just pulling the ALC reference down. Two different mechanisms are

employed: one is a very fast-acting circuit to increase the attenuation of the pin-diode attenuator, CR1, CR2, and CR3, and the second is the reference voltage being pulled away from the ALC amplifier device. An external Mute is a pull-down applied to J42 pin 10C, which completes a current path from the +12 VDC line through R78 and R139, the LED DS4 (Mute indicator), and the LED section of opto-isolator U11. These actions turn on the transistor section of U11 that applies -12 VDC through CR21 to U10A pin 3, and pulls down the reference voltage. This is a fairly slow action controlled by the low-pass filter function of R81 and C61. When the transistor section of U11 is on, -12 VDC is also connected through CR22 directly to the pin-diode attenuator circuit. This establishes a very fast muting action, by reverse biasing CR3. This action occurs in the event of an external VSWR fault.

4.3.1.11 ± 12 VDC Needed to Operate the Board

The ± 12 VDC connects to the board at J42C. The +12 VDC connects to J42C pin 16C and is filtered by L30, L41, and C80 before it is applied to the rest of the board. The -12 VDC connects to J42C pin 18C and is filtered by L31 and C81 before it is applied to the rest of the board.

The +12 VDC also connects through R261 to the zener diode VR3 that connects to ground, which generates the +6.8 VDC output to the rest of the board.

The +12 VDC also connects through R265 to the diodes CR30 and CR31 provide a .9 VDC reference output voltage VREF that temperature compensates for the two diodes in each corrector stage.

4.4 (A5) VHF/UHF Upconverter Module (1303829; Appendix B)

This module contains the Downconverter Board Assembly, the First Conversion

Board, LX Series, L-Band PLL Board, LX Series and the Upconverter Control Board, LX Series. This module takes an external IF and converts it to the final RF output frequency using two internally generated local oscillator frequencies.

4.4.1 (A1) Downconverter Board Assembly (1303834; Appendix B)

This board converts a signal at an input frequency of 1044 MHz to a broadcast VHF or UHF TV channel.

The IF at 1044MHz is applied to the board at J7, and is converted down to VHF or UHF by the mixer IC U6. The LO frequency is applied to the board at a level of +20 dBm at J8. The output of the mixer is applied to a 6 dB attenuator and then to a 900 MHz Low Pass filter. The filter is intended to remove any unwanted conversion products. The signal is next connected to the amplifier U2, and then a pin diode attenuator consisting of DS4, DS5 and their associated components. The attenuator sets the output level of the board and is controlled either by a manual gain pot R7, or an external AGC circuit. This automatic or manual mode of operation is controlled by the switch SW1. When in manual mode, the LED DS6 is illuminated.

The output of the pin attenuator is applied to another amplifier U3 and another low pass filter, before reaching the final amplifier U1. The output of the board is at J5 with a sample of the output available at J6, which is 20 dB in level below the signal at J5.

4.4.2 (A2) L-Band PLL Board (1303846; Appendix B)

This board generates an LO at a frequency of 1.1-1.9 GHz. The board contains a PLL IC U6, which controls the output frequency of a VCO. The PLL IC divides the output of the VCO down to 100kHz, and compares it to a 100kHz reference created by dividing down an external 10 MHz reference that is applied to the board

at J1 pin 4. The IC generates an error current that is applied to U3 and its associated components to generate a bias voltage for the VCO's AFC input.

There are two VCOs on the board, U4, which operates at 1.1-1.3 GHz for VHF channels, and U5, which operates at 1.5-1.9 GHz for UHF channels. The VCO in use is selected by a signal applied to J1 pin 20. This input enables the power supply either U1 or U2 for the appropriate VCO for the desired channel. U7 is a power supply IC that generates +5V for the PLL IC U6.

The output of each VCO is filtered by a low pass filter to remove any harmonic content and applied to a pin diode switch consisting of CR1, CR2, and their associated components. The selected signal is amplified by U9 and U10, then applied to a high pass filter and finally amplified to a level of approximately +21 dBm by U11. The output is connected to a low pass filter to remove any unwanted harmonic content and leaves the board at J3 at a level of +20 dBm.

4.4.3 (A3) First Conversion Board (1303838; Appendix B)

This board generates a 1 GHz LO signal using the VCO U9, the PLL IC U12, and the loop filter, C30-C33 and R49. The PLL IC compares a divided down sample of the VCO to a divided down sample of the transmitter's system 10 MHz reference.

The output of the VCO is amplified by U10 and U11 and applied to a low pass filter before being connected to an image rejection mixer consisting of U1, U2, U3 and U6. The 44 MHz IF input is connected to the board at J2, and then to the image rejection mixer. This mixer converts the 44 MHz input to an output frequency of 1044 MHz. The output of the mixer is amplified by U4 and applied to a band pass filter consisting of C2-C4 and some microstrip line sections. This

filter rejects any LO leakage at 1 GHz and also any unwanted out of band products. The output of the filter is amplified by U5 and then filtered before exiting the board at J1.

4.4.4 (A4) Upconverter Control Board (1304760; Appendix B)

This board performs a variety of functions, which include an interface between the other boards in the upconverter and the rest of the transmitter. It also has a microcontroller U8, which controls and monitors the functions of the other boards in the assembly.

The microcontroller communicates via an RS-485 interface with the transmitter's system control module. It reports any faults and metering information and receives channel information, which it passes along to the PLLs on the L-Band PLL Board and the First Conversion Board.

The board also generates various voltages used by the rest of the boards in the upconverter. U9 converts the +12V input to the board to +20V. U15 converts +12V to +5V for the on board 10 MHz crystal oscillator. U12 converts +12V to +9V for the L-Band PLL board and the First Conversion board. U13 and U14 generate +5V for the microcontroller.

The board also selects whether the internal or external 10 MHz reference source will be used. There is an onboard 10 MHz oscillator, U3, which is used when no external 10 MHz source is present. The Relay K1 is automatically switched to the external 10 MHz reference whenever it is present. The LED DS1 illuminates whenever the internal 10 MHz reference is used. The diode detector CR1 detects the presence of the 10 MHz external reference that connects to U2, which compares the detected level to a reference level and switches the relay whenever the reference is present. It also disables the internal oscillator whenever the external 10 MHz reference is being used.

The output of the relay is split to drive multiple outputs, some internal and some external. The external outputs leave the board at J1-22C and J1-31B and are used by the external receiver and modulator modules.

The board also contains AGC circuitry, which controls a pin diode attenuator on the Downconverter Board. There are three references used by the AGC circuit. The first is the AGC reference #1, which comes from the transmitter's driver module. The second is the AGC reference #2, which is a diode ORed sample of the output stages of the transmitter. The IC U5 normalizes the level of the AGC reference #1 and sets it at a level that is 0.2V less than the level of AGC reference #2. The AGC reference #1 and #2 are diode ORed with only the highest reference used by the AGC circuit.

The highest reference is compared to the ALC reference, which originated on the IF processor module, and the error voltage generated by U4D and applied to the external pin attenuator. The AGC will try to maintain a constant ratio between the ALC voltages and the higher of the two AGC voltages. If something in the output amplifier of the transmitter fails, the AGC reference #1 voltage will take over and the power will be regulated at the output of the driver.

4.5 (A4) Control Monitoring/Power Supply Module (110 VAC, 1301936 OR 220 VAC, 1303229; Appendix B)

The Control Monitoring/Power Supply Module Assembly contains (A1) a Power Protection Board (1302837), (A2) a 600 Watt Switching Power Supply, (A3) a Control Board (1302021), (A4) a Switch Board (1527-1406) and (A5) a LCD Display.

AC Input to Innovator LX Exciter/Amplifier Chassis Assembly

The AC input to the Exciter/Amplifier Chassis Assembly is connected from J1, part of a fused entry module, located on the rear of the chassis assembly to J50 on the Control Monitoring/Power Supply Module. There are two possible modules that can be part of your system, 1301936 for 110 VAC or 1303229 for 220 VAC operation. J50-10 is line #1 input, J50-8 is earth ground and J50-9 is line #2 input. The input AC connects to J1 on the Power Protection Board where it is fuse protected and connected back to J50, at J50-11 AC Line #1 and J50-12 AC Line #2, for distribution to the cooling Fan.

4.5.1 (A1) Power Protection Board (1302837; Appendix B)

The input AC connects through J1 to two 10 Amp AC fuses F1 and F2. The AC line #1 input connects from J1-1 to the F1 fuse. The AC line #1 input after the F1 fuse is split with one line connected back to Jack J1 Pin 4, which becomes the AC Line #1 to the Fan. The other line of the split connects to J4. The AC line #2 input connects from J1-3 to the F2 fuse. The AC line #2 input after the F2 fuse is split with one line connected back to Jack J1 Pin 5, which becomes the AC Line #2 to the Fan. The other line of the split connects to J2. J1-2 is the earth ground input for the AC and connects to J3.

Three 150 VAC, for 115 VAC input, or three 275 VAC, for 230 VAC input, MOVs are connected to the input AC for protection. One connects from each AC line to ground and one connects across the two lines. VR1 connects from J4 to J2, VR2 connects from J4 to J3 and VR3 connects from J2 to J3.

4.5.1.1 +12 VDC Circuits

+12 VDC from the Switching Power Supply Assembly connects to J6 on the board. The +12 VDC is divided into four separate circuits each with a 3 amp self resetting fuse, PS3, PS4, PS5 and PS6.

The polyswitch resettable fuses may open on a current as low as 2.43 Amps at 50°C, 3 Amps at 25°C or 3.3 Amps at 0°C. They definitely will open when the current is 4.86 Amps at 50°C, 6 Amps at 25°C or 6.6 Amps at 0°C.

PS3 protects the +12 VDC 2 Amp circuits for the System Controller, the Amplifier Controller and the Spare Slot through J62 pins 7, 8, 9 and 10. If this circuit is operational, the Green LED DS3, mounted on the board, will be lit.

PS4 protects the +12 VDC 2 Amp circuits for the Modulator and the IF Processor through J62 pins 13, 14, 15 and 16. If this circuit is operational, the Green LED DS4, mounted on the board, will be lit

PS5 protects the +12 VDC 2 Amp circuits for the Upconverter through J62 pins 17, 18, 19 and 20. If this circuit is operational, the Green LED DS5, mounted on the board, will be lit

PS6 protects the +12 VDC 2 Amp circuits for the Remote through J63 pins 17, 18, 19 and 20. If this circuit is operational, the Green LED DS6, mounted on the board, will be lit

4.5.1.2 -12 VDC Circuits

-12 VDC from the Switching Power Supply Assembly connects to J5 on the board. The -12 VDC is divided into two separate circuits each with a 3 amp self resetting fuse, PS1 and PS2.

PS1 protects the -12 VDC 2 Amp circuits for the System through J63 pins 1, 2, 3 and 4. If this circuit is operational, the Green LED DS1, mounted on the board, will be lit

PS2 protects the -12 VDC 2 Amp circuits for the Remote through J62 pins 1, 2, 3 and 4. If this circuit is operational, the Green LED DS2, mounted on the board, will be lit

The connections from J62 and J63 of the Power Protection Board are wired to J62 and J63 on the Control Board.

4.5.2 (A3) Control Board (1302021; Appendix B)

In this transmitter, control monitoring functions and front panel operator interfaces are found on the Control Board. Front panel operator interfaces are brought to the control board using a 26 position conductor ribbon cable that plugs into J60. The control board controls and monitors the Power Supply and Power Amplifier module through a 16 position connector J61 and two 20 position connectors J62 & J63.

4.5.2.1 Schematic Page 1

U1 is an 8 bit RISC microcontroller that is in circuit programmed or programmed using the serial programming port J4 on the board. When the microcontroller, U1, is held in reset, low on pin 20, by either the programming port or the external watchdog IC (U2), a FET Q1 inverts the reset signal to a high that connects to the control lines of U5, an analog switch. The closed contacts of U5 connects the serial programming lines from J4 to U1. LED DS10 will be lit when programming port J4 is used.

U2 is a watchdog IC used to hold the microcontroller in reset, if the supply voltage is less the 4.21 VDC; (1.25 VDC < Pin 4 (IN) < Pin 2 (Vcc). The watchdog momentarily resets the microcontroller, if Pin 6 (ST) is not clocked every second. A manual reset switch S1 is provided but should not be needed.

Diodes DS1 through DS8 are used for display of auto test results. A test board is used to execute self test routines. When the test board is installed, Auto_Test_1 is held low and Auto_Test_2 is allowed to float at 5 VDC. This is the signal to start the auto test routines.

U3 and U4 are used to selectively enable various input and output ICs found on pages 2 & 3 of the schematic.

U1 has two serial ports available. In this application, one port is used to communicate with transmitter system components where U1 is the master of a RS-485 serial bus. The other serial port is used to provide serial data I/O where U1 is not the master of the data port. A dual RS-232 port driver IC and a RS-485 Port driver are also in the second serial data I/O system. The serial ports are wired such that serial data input can come through one of the three serial port channels. Data output is sent out through each of the three serial port channels.

Switch SW1, transmitter operation select, is used to select either transmitter operation or exciter/driver operation. When the contacts of SW1 are closed, transmitter operation is selected and the power monitoring lines of the transmitter's power amplifier are routed to the system power monitoring lines.

4.5.2.2 Schematic Page 2

U9 is a non-inverting transceiver IC that provides 2 way asynchronous communication between data busses. The IC is used as an input buffer to allow the microcontroller to monitor various digital input values.

Digital output latch circuits are used to control system devices. Remote output circuits are implemented using open drain FETs, Q13, Q14, Q16, and Q17, with greater than 60 Volt drain to source voltage ratings.

Remote digital inputs are diode protected, using CR6, CR7, CR8 and CR9 with a 1 k Ω pull-up resistor, to +5 VDC. If the remote input voltage is greater than about 2 Volts or floating, the FET is turned on and a logic low is applied to the digital input buffer, U9. If the

remote input voltage is less than the turn on threshold of the FET (about 2 VDC), a logic high is applied to the digital input buffer, U9.

Four of the circuits on page two of the schematic, which include Q2, Q9, Q19 and Q21, are auxiliary I/O connections wired for future use. They are wired similar to the remote digital inputs but include a FET, Q5, Q12, Q20 and Q22, for digital output operations. To operate these signals as inputs, the associated output FET must be turned off. The FETs are controlled by U10 and U12, analog input multiplexer ICs.

4.5.2.3 Schematic Page 3

U13, U14, U15, U16, U17 and U18 are 3 state non-inverting transceiver ICs that provide 2 way asynchronous communication between data busses. The ICs are used as input buffers to allow the microcontroller to monitor various digital input values. The digital inputs to the ICs utilize a 10 k Ω pull-up resistor. The buffer IC, U18, used for data transfer to the display is wired for read and write control.

4.5.2.4 Schematic Page 4

U19 and U20 are digitally controlled analog switches that provide samples back to the microprocessor. Each analog input is expected to be between 0 and 5 VDC. If a signal exceeds 5.1 VDC, a 5.1 Volt zener diode clamps the signals voltage, to prevent damage to the IC. Most signals are calibrated at their source, however two dual serial potentiometers ICs are used to calibrate four signals, System Visual/Average Power, System Aural Power, System Reflected Power and the Spare AIN 1. For these four circuits, the input value is divided in half before it is applied to an op-amp. The serial potentiometer is used to adjust the output signal level to between 80 and 120% of the input signal level. Serial data, serial clock and serial pot enables are supplied by the microprocessor to the dual serial potentiometer ICs. J62 and J63 are two

20 position connectors that provide the +12 VDC and -12 VDC power through the Power Protection Board. The ± 12 VDC generated by the switching power supply connects to J62 and J63 after being fuse protected on the Power Protection Board.

4.5.2.5 Schematic Page 5

There are three dual element, red/green, common cathode LED indicators mounted on the front panel of the sled assembly; DC OK, Operate and Fault.

There are three, the fourth is a spare, identical circuits that drive the front panel mounted LED indicators. The levels on the 1, 2, 3 and 4 LED Control Lines, for both the red and green LEDs, are generated by the IC U11 as controlled by the DATABUS from the microprocessor U1.

Each LED controller circuit consists of an N-Channel MOSFET w/internal diode that controls the base of an N-P-N transistor in an emitter follower configuration. The emitter of the transistor connects the LED.

With the LED control line LOW, the MOSFET is Off, which causes the base of the transistor to increase towards +12 VDC, forward biasing the transistor. With the transistor forward biased, current will flow from ground through the LED, the transistor and the current limiting resistors in the collector to the +12 VDC source. The effected LED will light.

With the LED control line HIGH, the MOSFET is On, which causes the base of the transistor go toward ground potential, reverse biasing the transistor. With the transistor reverse biased, no current through the transistor and LED, therefore the effected LED will not light.

A third color, amber, can also be generated by having both transistors

conducting, both control lines LOW. The amber color is produced because the current applied to the green element is slightly greater than the red element. This occurs because the current limiting resistors have a smaller ohmage value in the green circuit.

There are four voltage regulators, three for +5 VDC and one for +7 VDC, which are used to power the Control Board. +12 VDC is applied to U25 the +7 VDC regulator that produces the +7 VDC, which is applied to the LEDs mounted on the board. The +7V is also connected to the input of U26 a precision +5.0 Volt regulator. The +5.0 VDC regulator output is used to power the analog circuits and as the microcontroller analog reference voltage. Another two +5 Volt regulator circuits U27, +5V, and U8, +5 Vserial, are used for most other board circuits.

4.5.3 (A4) Switch Board (1527-1406; Appendix B)

The switch board provides five front-panel momentary contact switches for user control and interface with the front-panel LCD menu selections. The switches, SW1 to SW5, complete the circuit through connector J1 to connector J2 that connects to J1 on (A5) the 20 Character by 4 line LCD Display. J1 on the switch board is also cabled to the Control Board. When a switch is closed, it connects a logic low to the control board that supplies the information from the selected source to the display. By pushing the button again, a different source is selected. This occurs for each push button. Refer to Chapter 3 Section 3.5.3, for more information on the Display Menu Screens.

4.5.4 (A2) Switching Power Supply Assembly

The power supply module contains a switching power supply, an eight position terminal block for distributing the DC voltages, a three position terminal block to which the AC Input connects. Jack J1 connects to the Control Board and

supplies DC OK, at J1-4 & 3, and AC OK, at J1-2 & 1, status to the control board. A Power Supply enable connects from the control board to the power supply at V1-6 & 7. The power supply is configured for three output voltages +12V, -12V, at the 8 position terminal block, and a main output power of +32 VDC at J50 pin A (+) and J50 pin B (Rtn). The power supply is power factor corrected to .98 for optimum efficiency and a decrease in energy consumption. For safety purposes all outputs are over voltage and over current protected. This supply accepts input voltages from 85 to 264 volts AC, but the power entry module, for the exciter/amplifier chassis, must be switched to the proper input voltage setting, for the transmitter to operate.

4.6 (A4) Power Amplifier Module Assembly (1303770; Appendix B)

NOTE: Used in 10W-100W Transmitters or as a driver in systems above 2kW. In a 1kW system, a 1303771 Driver PA Assembly is used and in a 2kW system, a 1303874 Driver PA Assembly is used. The Power Amplifier Module Assembly contains (A1) a 1 Watt UHF Amplifier Module Assembly (1302891), (A2) a 40 Watt UHF Module Assembly (1304490), (A3) UHF RF Module Pallet Assembly (1300116), (A4) a Coupler Board Assembly (1301949), (A5) an Amplifier Control Board (1301962) and (A6) a Temperature Sensor IC.

The RF from the Upconverter Module Assembly connects from the Upconverter RF Output BNC Jack J23, through a cable, to the PA RF Input BNC Jack J24, located on the rear of the exciter/amplifier chassis assembly.

4.6.1 (A1) 1-Watt UHF Module Assembly (1302891; Appendix B)

The 1-watt UHF module assembly provides radio frequency interference (RFI) and electromagnetic interference

(EMI) protection, as well as the heatsink, for the 1-watt UHF amplifier board (1302762) that is mounted inside the assembly. The assembly has approximately 17 dB of gain.

The RF input to the assembly connects to SMA Jack J3. The amplified RF output of the assembly is at the SMA Jack J4. Typically, with an input signal of +4 dBm at J1 of the assembly, an output of +21 dBm can be expected at J2.

The +12-VDC bias voltage connects through J5, a RF-bypassed, feed-through capacitor, to the amplifier board. The -12-VDC bias voltage connects through J6, a RF-bypassed, feed-through capacitor, to the amplifier board. E1 on the assembly connects to Chassis Ground.

4.6.2 (A1-A1) 1-Watt UHF Amplifier Board (1302761; Appendix B)

The 1-watt UHF amplifier board is mounted in the 1-watt UHF amplifier assembly (1302891) and provides approximately +17 dB of gain.

The UHF signal enters the board at J3, a SMA connector, and is applied to U3 an IC hybrid coupler assembly that splits the input signal into two equal parts. The two amplifier paths are identical using Q4 and Q5, 1-Watt HFETs as the amplifier devices. Each HFET has approximately 14 dB of gain.

The drain voltage needed to operate each HFET is obtained from the +12 VDC line that connects to the board at J5 and is regulated down to +8.25 volts by U4. The gate negative bias voltage is obtained from the -12 VDC line that connects to the board at J6.

The amplified outputs of the HFETs are applied to U2 an IC hybrid coupler assembly that combines the amplified signals into a single output that connects to J4 of the board.

4.6.3 (A4-A1) 40 Watt UHF Amplifier Assembly (1304490; Appendix B)

The output of the UHF filter is connected to the input J1 of (A2) the 40 Watt UHF amplifier assembly (Figure 4-1). The assembly is made up of a (51-5378-308-00) module, which operates class AB and is a highly linear broadband amplifier for the frequency range of 470 to 860 MHz. It can deliver an output power of 40 watts (CW) with approximately 14 dB of gain.

The amplification circuit consists of LDMOS transistors V804 and V805 connected in parallel and operating in class AB. The paralleling network is achieved with the aid of 3 dB couplers Z802 and Z803. A further 3 dB coupler

Z801, in conjunction with capacitors C800 and C819, serves as a phase shifter. Phase alignment, for the complete amplifier, as well as quiescent current settings are achieved by means of potentiometers R807 and R808. The settings are factory implemented and should not be altered. PIN diodes V810 & V811 form a variable-damping circuit that is used to adjust the amplification of the 40-watt module. The level adjustment is performed with the Gain potentiometer R838. A readjustment of the amplification may be required, after repair work, to ensure that the Power Amplifiers in multiple PA transmitters deliver the same output power.

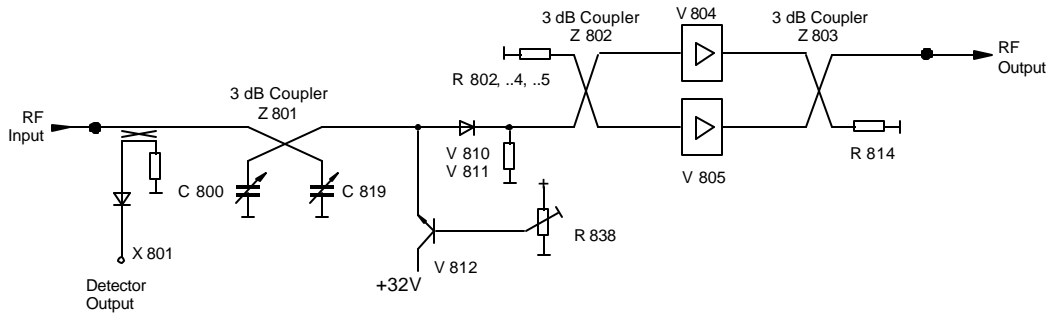

Figure 4-1: 40 Watt UHF Amplifier Module

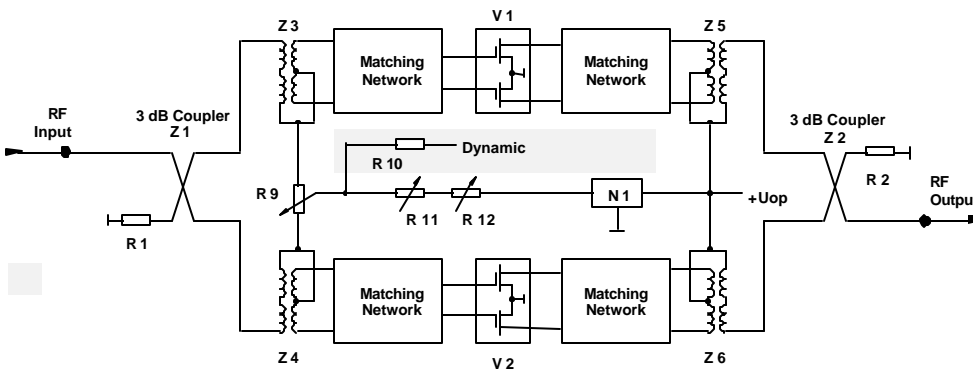

Figure 4-2. UHF Amplifier Module, 250 Watts

4.6.4 (A3) UHF Module Assembly, RF Module Pallet, Philips (1300116; Appendix B)

The UHF Module Assembly, 250-watt module (Figure 4-2) is a broadband amplifier for the frequency range 470 to 860 MHz. The amplifier is capable of delivering an output power of $70 W_{\text{rms}}$. The amplification is approximately 13 dB.

The amplification circuit consists of the parallel connected push-pull amplifier blocks V1 and V2 operating in class AB. In order to match the transistor impedance to the characteristic impedance of the input and output sides, matching networks are placed ahead and behind the amplifier blocks. Transformers Z3 to Z6 serve to balance the input and output signals. The paralleling circuit is achieved with the aid of 3-dB couplers Z1 and Z2.

The working point setting is factory implemented by means of potentiometers R9, R11, and R12 and should not be altered.

4.6.5 (A4) Coupler Board Assembly (1301949; Appendix B)

The UHF coupler board assembly provides forward and reflected power samples of the output to (A5) the amplifier control board where it connects to the input of the overdrive-protection circuit.

The RF input to the UHF coupler assembly, from the 250 Watt UHF amplifier module, connects to SMA jack J1. The RF is connected by a stripline track to the SMA type connector RF Output jack J2. A hybrid-coupler circuit picks off a power sample that is connected to SMA type connector jack J3 as the forward power sample. Another power sample is taken from the coupler circuit that is connected to the SMA type connector jack J6 as the reflected power sample. Two 500 terminations, used as dissipation loads, connect to the reject

and reflected ports, J5 and J4, of the coupler.

4.6.6 (A5) Amplifier Control Board (1303682 or 1301962; Appendix B)

The amplifier control board provides LED fault and enable indications on the front panel of the module and also performs the following functions: overdrive cutback, when the drive level reaches the amount needed to attain 110% output power; and overtemperature, VSWR, and overdrive faults. The board provides connections to the LCD Display for monitoring the % Reflected Power, % Output Power, and the power supply voltage.

If the Module OK LED, located on the front panel, is Red and blinking, a fault is present. The meaning of the blinking LED is as follows.

- 1 Blink:** Indicates Amplifier Current Fault.
- 2 Blinks:** Indicate Temperature Fault.
- 3 Blinks:** Indicate +32V Power Supply Over Voltage Fault.
- 4 Blinks:** Indicate +32V Power Supply Under Voltage Fault.
- 5 Blinks:** Indicate Reflected Power Fault.
- 6 Blinks:** Indicate +12V or -12V Power Supply Fault

4.6.6.1 Schematic Page 1

U4, located upper center of page, is an in circuit microcontroller. The controller is operated at the frequency of 3.6864 MHz using crystal Y1. Programming of this device is performed through the serial programming port J2. U4 selects the desired analog channel of U1 through the settings of PA0-PA3. The outputs of Port A must be set and not changed during an analog input read of channels PA5-PA7. PA4 of U4 is a processor operating LED that monitors the ± 12 VDC. PA5 is used to monitor the +12VDC supply to the board. PA6 is the selected channel of analog switch U1. PA7 is connected to a via, V10, for future access.

U6 is a serial to RS-485 driver IC. U7 is a watchdog IC used to hold the microprocessor in reset, if the supply voltage is less than 4.21 VDC. U7 momentarily resets the microcontroller if Pin 6 (!ST) is not clocked every second. A manual reset switch is provided but should not be needed.

In the Upper left corner, U3 is used to determine where the amplifier control board is located. The eight inputs come from the main amp connector and are used to set the SCADA address of the controller. Pull-up resistors set a default condition of logic high.

U5 below U3 is used for getting digital input information of the board. Page two has several monitoring circuits that provide information on the amplifier's status. Many of these circuits automatically shut down the amplifier if a specific fault occurs.

U8 below U5 is used to control four board mounted status LEDs. A FET is turned On to shunt current away from the LED to turn it Off. U9 below U8 is used to enable different features within the software. Actual use is to be determined.

4.6.6.2 Schematic Page 2

In the lower right corner are voltage regulator circuits. U22 should allow for 0.14 amps of power using its 92 C/W rating if $T_a = 60^\circ\text{C}$ max and $T_j = 125^\circ\text{C}$ max 0.26 amps can be obtained from U22 if the mounting pad is 0.5 square inches. The controller will not need this much current. U23 and U24 are low drop out +5 VDC, voltage regulators with a tolerance greater than or equal to 1%. 100mA of current is available from each device but again the controller will not need this much current.

In the upper left section are circuits with U12 and U13. U12 is used to generate a regulated voltage that is about 5 volts less than the +32 VDC supply, approximately +26.25 VDC. When the +32 VDC supply is enabled, the circuitry

around U13B is used to provide gate voltage to Q10 that is 5 volts greater than the source pin of this FET. The gate of Q10 can be turned Off by any one of a few different circuits. U10A is used to turn Off the gate of Q10 in the event of high current in amplifier #1. At 0.886 VDC the current to amplifier #1 should be greater than 5 Amps. U11B is used to turn off the Q10 FET, if high current is detected in amplifier #2. U11A is used to turn off the Q10 FET, if high current is detected in amplifier #3. With 2.257 VDC at Pin 5 of U11B or Pin 3 of U11A, the voltage output of current sense amplifier U17 or U18 at high current shut down should be greater than 15 Amps.

U14B is used to turn Off the gate of Q10 in the event of high power supply voltage, approximately +35.4 VDC. U14A is used to keep the FET disabled in the event of low power supply voltage, approximately +25.4 VDC.

4.6.6.3 Current monitoring sections of the board.

The ICs U16, U17 and U18 along with associated components set up the current monitoring sections of the board. R67, R68 and R69 are 0.010/5W 1% through hole resistors used for monitoring the current through several sections of the amplifier. The voltage developed across these resistors are amplified for current monitoring by U16, U17 or U18. The LT1787HVCS8 precision high side current sense IC amplifier accepts a maximum voltage of 60 VDC. The 43.2 k Ω resistor from pin 5 to ground sets the gain of the amplifier to about 17.28. This value is not set with much accuracy since the manufacturer internally matches the resistors of this part but their actual resistance value is not closely defined. A trimming resistor is suggested to give a temperature stability of -200 ppm/C, but instead the microcontroller will determine the exact gain of the circuit and use a correction factor for measurements. Circuit loading components are located in the lower portion of each current monitoring circuit. These components

allow for short duration high current loading of the supply. By measuring the current through the sense resistor with and without the additional four 30.1 Ω 1% resistors. For very short duration pulses, a 1206 resistor can handle up to 60 watts. The processor requires 226 uSec per conversion. A supply voltage of +32 VDC will pass 1.06 amps + 1% through the load resistors.

A6 is a temperature sensor thermistor that is used to monitor the temperature of the module's heat sink. It connects to J6 pins 1 & 2 on the board and is wired to the comparator IC U10B. If the temperature increases above 75°C the output will go Low that is used as a temperature fault output, which generates a Fault alert at U15A and disables Amplifier #1.

4.6.6.4 Schematic Page 3, Aural, Visual/Average and Reflected power detector sections of the board.

A Forward Power Sample enters the board at SMA Jack J3 and is split. One part connects to J4 on the board that is cabled to J1, the SMA Forward Power Sample Jack, located on the front panel of the assembly. The other part of the split forward power sample is detected by CR17 and the DC level amplified by U25A. The output of U25A at pin 1 is split with one part connected to the Aural Power sample, which is not used in a digital transmitter. The other split output connects to U265A that is part of the Forward Average Power circuit. The detected level is connected to L4 that is part of an intercarrier notch filter circuit that is tuned to eliminate the 4.5 MHz aural intercarrier, if present. The Average power sample is amplified by U26D and connected through the average calibration pot R166 to U26C. The output of U26C is connected to the comparator IC U26B that has Aural Null and Offset Null, if present in the system, connected to the other input. The output Average Forward power level connects to J9 pin 2 of the board.

A Reflected Power Sample enters the board at SMA Jack J5 and is detected by CR20 and the DC level amplified by U28B. The output of U28B at pin 7 is connected through the reflected calibration pot R163 to U28C. The output is split with one part connected to J9 pin 5, the Reflected Power Output level of the board. The other part of the split from U28C connects to the comparator IC U28D that has a reference level connected to the other input. If the reflected level increases above the reference level a low output is produced and connected to the Reflected Power Shutdown circuit at CR28. The low shuts off Q14 causing pin 3 to go high that is connected to the inverter U15C. The output of U15C goes low producing a Reflected Power Fault that is connected to an output of the board, the Fault Alert circuit and also shuts down Amplifier #1. Gain of the power measurements is completed through software. Only the Aural Null and Offset Null need to be done through front panel pots.

This completes the description of the Power Amplifier Module Assembly that is used with 10W to 100 W transmitters.

4.6.7 (A9) Bandpass and (A10) Trap Filter

NOTE: If your system contains a Teracom manufactured tunable filter assembly, refer to the manufacturers manual included with the filter for the description of the filter.

The RF Output of the exciter assembly in a 10W-100W System is connected to (A9) the Bandpass Filter and then to (A10) the UHF Trap Filter Assembly. Both filters are tuned to provide high out of band rejection of unwanted products. The filtered RF Output at the "N" connector jack (J2) of the Trap Filter is cabled to the Antenna for your System.

4.7 (A4) Driver Amplifier Module Assembly { 1303771(1kW) or 1303874(2kW); Appendix B }

NOTE: In a 1kW system a 1303771 Driver PA Assembly is used and in a 2kW system a 1303874 Driver PA Assembly is used as the driver for high power transmitters with external PA assemblies. A 1303770 Power Amplifier is used in a 10W-100W Transmitter or it is used as a driver in Systems above 2kW.

The Driver Amplifier Module Assembly contains (A1) a 1 Watt UHF Amplifier Module Assembly (1302891), (A2) a 40 Watt UHF Module Assembly (1304490) in a 1kW system or a RF Module Pallet, Philips (1300116) in a 2kW system, (A4) a Coupler Board Assembly (1227-1316), (A5) an Amplifier Control Board (1301962) and (A6) a Temperature Sensor IC.

The RF from the Upconverter Module Assembly connects from the Upconverter RF Output BNC Jack J23, through a cable, to the PA RF Input BNC Jack J24, located on the rear of the exciter/amplifier chassis assembly.

4.7.1 (A1) 1-Watt UHF Module Assembly (1302891; Appendix B)

The 1-watt UHF module assembly provides radio frequency interference (RFI) and electromagnetic interference (EMI) protection, as well as the heatsink, for the 1 watt UHF amplifier board (1302761) that is mounted inside the assembly.

The +12-VDC bias voltage connects through J5, a RF-bypassed, feed-through capacitor, to the amplifier board. The -12-VDC bias voltage connects through J6, a RF-bypassed, feed-through capacitor, to the amplifier board. E1 on the assembly connects to Chassis ground.

4.7.2 (A1-A1) 1 Watt UHF Amplifier Board (1302761; Appendix B)

The 1 watt UHF amplifier board provides approximately +17 dB of gain. Typically, in a 1kW system with an input signal of +6 dBm at J1 of the assembly, an output of +23 dBm can be expected at J2. In a 2kW system an input signal of +6 dBm provides an output of +23 dBm.

The UHF signal enters the board at J3, a SMA connector, and is applied to U3 an IC hybrid coupler assembly that splits the input signal into two equal parts. The two amplifier paths are identical using Q4 and Q5, 1-Watt HFETs as the amplifier devices. Each HFET has approximately 14 dB of gain. The drain voltage needed to operate each HFET is obtained from the +12 VDC line that connects to the board at J5 and is regulated down to +8.25 volts by U4. The gate negative bias voltage is obtained from the -12 VDC line that connects to the board at J6. The amplified outputs of the HFETs are applied to U2 an IC hybrid coupler assembly that combines the amplified signals into a single output that connects to J4 of the board.

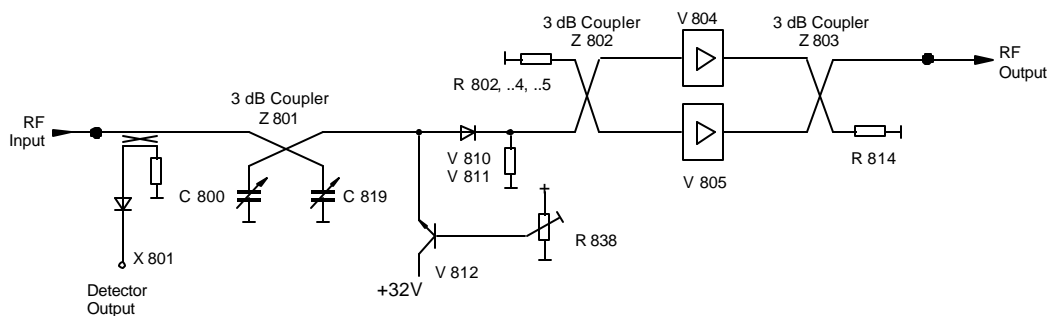

Figure 4-3: 40 Watt UHF Amplifier Module

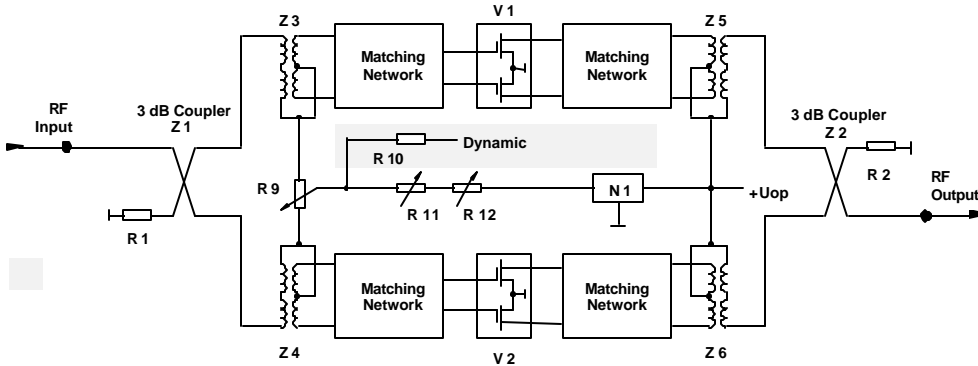

Figure 4-4. 250 Watt UHF Amplifier Module

4.7.3 (A2) 40 Watt UHF Amplifier Assembly (1304490; Appendix B)
(NOTE: Used in 1kW Systems)

The output of the UHF filter is connected to the input J1 of (A2) the 40 Watt UHF amplifier assembly (Figure 4-3). The assembly is made up of a (51-5378-308-00) module, which operates class AB and is a highly linear broadband amplifier for the frequency range of 470 to 860 MHz. It can deliver an output power of 40 watts (CW) with approximately 13 dB of gain. With a typical input of +23dBm an output of +36.2dBm is expected. The output is set as needed to provide the drive level to the external PA Assemblies.

The amplification circuit consists of LDMOS transistors V804 and V805 connected in parallel and operating in class AB. The paralleling network is achieved with the aid of 3 dB couplers Z802 and Z803. A further 3 dB coupler Z801, in conjunction with capacitors C800 and C819, serves as a phase shifter. Phase alignment, for the complete amplifier, as well as quiescent current settings are achieved by means of potentiometers R807 and R808. The settings are factory implemented and should not be altered.

PIN diodes V810 & V811 form a variable-damping circuit that is used to adjust the amplification of the 40-watt module. The adjustment is performed with the Gain potentiometer R838. A readjustment of the amplification may

be required, after repair work, to ensure that the PAs in multiple PA transmitters deliver the same output power.

OR 4.7.3.1 (A3) 250 Watt UHF Amplifier Assembly (1300116; Appendix B)
(NOTE: Used in 2kW Systems)

The UHF Module Assembly, 250-watt module (Figure 4-4) is a broadband amplifier for the frequency range 470 to 860 MHz. The amplifier is capable of delivering an output power of 70 W_{rms}. The amplification is approximately 12 dB. With a typical input of +27dBm an output of +39dBm is expected.

The amplification circuit consists of the parallel connected push-pull amplifier blocks V1 and V2 operating in class AB. In order to match the transistor impedance to the characteristic impedance of the input and output sides, matching networks are placed ahead and behind the amplifier blocks. Transformers Z3 to Z6 serve to balance the input and output signals. The paralleling circuit is achieved with the aid of 3-dB couplers Z1 and Z2.

The working point setting is factory implemented by means of potentiometers R9, R11, and R12 and should not be altered.

4.7.4 (A4) Coupler Board Assembly (1227-1316; Appendix B)

The UHF coupler board assembly provides forward and reflected power samples of the

output to (A5) the amplifier control board where it connects to the input of the overdrive-protection circuit.

The RF input to the UHF coupler assembly, from the 40 Watt UHF amplifier module, connects to SMA jack J1. The RF is connected by a stripline track to the SMA type connector RF Output jack J2. A hybrid-coupler circuit picks off a power sample that is connected to SMA type connector jack J3 as the forward power sample. Another power sample is taken from the coupler circuit that is connected to SMA type connector jack J6 as the reflected power sample. Two 500 terminations, used as dissipation loads, connect to the reject and reflected ports, J5 and J4, of the coupler.

4.7.5 (A5) Amplifier Control Board (1303682 or 1301962; Appendix B)

The amplifier control board provides LED fault and enable indications on the front panel of the module and also performs the following functions: overdrive cutback, when the drive level reaches the amount needed to attain 110% output power; and overtemperature, VSWR, and overdrive faults. The board also provides connections to the LCD Display for monitoring the % Reflected Power, % Output Power, and the power supply voltage.

If the Module OK LED, located on the front panel, is Red and blinking, a fault is present. The meaning of the blinking LED is as follows.

- 1 Blink:** Indicates Amplifier Current Fault.
- 2 Blinks:** Indicate Temperature Fault.
- 3 Blinks:** Indicate +32V Power Supply Over Voltage Fault.
- 4 Blinks:** Indicate +32V Power Supply Under Voltage Fault.
- 5 Blinks:** Indicate Reflected Power Fault.
- 6 Blinks:** Indicate +12V or -12V Power Supply Fault

4.7.5.1 Schematic Page 1

U4, located upper center of page, is an in circuit microcontroller. The controller is operated at the frequency of 3.6864 MHz using crystal Y1. Programming of this device is performed through the serial programming port J2. U4 selects the desired analog channel of U1 through the settings of PA0-PA3. The outputs of Port A must be set and not changed during an analog input read of channels PA5-PA7. PA4 of U4 is a processor operating LED that monitors the +/- 12 VDC. PA5 is used to monitor the +12VDC supply to the board. PA6 is the selected channel of analog switch U1. PA7 is connected to a via, V10, for future access.

U6 is a serial to RS-485 driver IC. U7 is a watchdog IC used to hold the microprocessor in reset, if the supply voltage is less than 4.21 VDC. U7 momentarily resets the microcontroller if Pin 6 (!ST) is not clocked every second. A manual reset switch is provided but should not be needed.

Upper left corner U3 is used to determine where the amplifier control board is located. The eight inputs come from the main amp connector and are used to set the SCADA address of the controller. Pull-up resistors set a default condition of logic high.

U5 below U3 is used for getting digital input information of the board. Page two has several monitoring circuits that provide information on the amplifier's status. Many of these circuits automatically shut down the amplifier if a specific fault occurs.

U8 below U5 is used to control four board mounted status LEDs. A FET is turned On to shunt current away from the LED to turn it Off. U9 below U8 is used to enable different features within the software. Actual use is to be determined.

4.7.5.2 Schematic Page 2

In the lower right corner are voltage regulator circuits. U22 should allow for 0.14 amps of power using its 92 C/W rating if $T_a = 60^\circ\text{C}$ max and $T_j = 125^\circ\text{C}$ max 0.26 amps can be obtained from U22 if the mounting pad is 0.5 square inches. The controller will not need this much current.

U23 and U24 are low drop out +5 VDC, voltage regulators with a tolerance greater than or equal to 1%. 100mA of current is available from each device but again the controller will not need this much current.

In the upper left section are circuits with U12 and U13. U12 is used to generate a regulated voltage that is about 5 volts less than the +32 VDC supply, approximately +26.25 VDC. When the +32 VDC supply is enabled, the circuitry around U13B is used to provide gate voltage to Q10 that is 5 volts greater than the source pin of this FET. The gate of Q10 can be turned Off by any one of a few different circuits.

U10A is used to turn Off the gate of Q10 in the event of high current in amplifier #1. At 0.886 VDC the current to amplifier #1 should be greater than 5 Amps. U11B is used to turn off the Q10 FET, if high current is detected in amplifier #2. U11A is used to turn off the Q10 FET, if high current is detected in amplifier #3. With 2.257 VDC at Pin 5 of U11B or Pin 3 of U11A, the voltage output of current sense amplifier U17 or U18 at high current shut down should be greater than 15 Amps.

U14B is used to turn Off the gate of Q10 in the event of high power supply voltage, approximately +35.4 VDC. U14A is used to keep the FET disabled in the event of low power supply voltage, approximately +25.4 VDC.

4.7.5.3 Current Monitoring sections of the Board.

The ICs U16, U17 and U18 along with associated components set up the current monitoring sections of the board. R67, R68 and R69 are 0.010/5W 1% through hole resistors used for monitoring the current through several sections of the amplifier. The voltage developed across these resistors is amplified for current monitoring by U16, U17 or U18. The LT1787HVCS8 precision high side current sense IC amplifier accepts a maximum voltage of 60 VDC. The 43.2 kO resistor from pin 5 to ground sets the gain of the amplifier to about 17.28. This value is not set with much accuracy since the manufacturer internally matches the resistors of this part but their actual resistance value is not closely defined. A trimming resistor is suggested to give a temperature stability of -200 ppm/C. The microcontroller will determine the exact gain of the circuit and use a correction factor for measurements. Circuit loading components are located in the lower portion of each current monitoring circuit. These components allow for short duration high current loading of the supply. The correction factor is determined by measuring the current through the sense resistor with and without the additional four 30.1 O 1% resistors. For very short duration pulses, a 1206 resistor can handle up to 60 watts. The processor requires 226 uSec per conversion. A supply voltage of +32 VDC will pass 1.06 amps + 1% through the load resistors.

A6 is a temperature sensor thermistor that is used to monitor the temperature of the module's heat sink. It connects to J6 pins 1 & 2 on the board and is wired to the comparator IC U10B. If the temperature increases above 75°C the output will go Low that is used as a temperature fault output, which generates a Fault alert at U15A and disables Amplifier #1.

4.7.5.4 Schematic Page 3, Aural, Visual/Average and Reflected Power Detector sections of the Board.

A Forward Power Sample enters the board at SMA Jack J3 and is split. One part connects to J4 on the board that is cabled to J1, the SMA Forward Power Sample Jack, located on the front panel of the assembly. The other part of the split forward power sample is detected by CR17 and the DC level amplified by U25A. The output of U25A at pin 1 is split with one part connected to the Aural Power sample, which is not used in a digital transmitter. The other split output connects to U265A that is part of the Forward Average Power circuit. The detected level is connected to L4 that is part of an intercarrier notch filter circuit that is tuned to eliminate the 4.5 MHz aural intercarrier, if present. The Average power sample is amplified by U26D and connected through the average calibration pot R166 to U26C. The output of U26C is connected to the comparator IC U26B that has Aural Null and Offset Null, if present in the system, connected to the other input. The output Average Forward power level connects to J9 pin 2 of the board.

A Reflected Power Sample enters the board at SMA Jack J5 and is detected by CR20 and the DC level amplified by U28B. The output of U28B at pin 7 is connected through the reflected calibration pot R163 to U28C. The output is split with one part connected to J9 pin 5, the Reflected Power Output level of the board. The other part of the split from U28C connects to the comparator IC U28D that has a reference level connected to the other input. If the reflected level increases above the

reference level a low output is produced and connected to the Reflected Power Shutdown circuit at CR28. The low shuts off Q14 causing pin 3 to go high that is connected to the inverter U15C. The output of U15C goes low producing a Reflected Power Fault that is connected to an output of the board, the Fault Alert circuit and also shuts down Amplifier #1. Gain of the power measurements is completed through software. Only the Aural Null and Offset Null need to be done through front panel pots.

This completes the description of the Driver Amplifier Module Assembly, which is used in high power transmitters with external PA assemblies.

The RF output of the driver amplifier module assembly connects to the output of the Exciter/Amplifier chassis assembly at the "N" type connector Jack J25. In a High Power System, the RF output at J25 connects to J200 the RF input to the external Power Amplifier Assembly.

NOTE: In systems with two exciters and an exciter switcher, the outputs of the two exciters connect to the exciter switcher tray and the RF output from the selected exciter connects to J200 the RF input to the external Power Amplifier Assembly, or a splitter assembly, or directly to the bandpass filter for the system.

This also completes the description for the entire Exciter/Amplifier chassis assembly.

Chapter 5 Detailed Alignment Procedures

This transmitter/translator was aligned at the factory and should not require additional adjustments to achieve normal operation.

The transmitter takes the baseband audio and video inputs and converts them to the desired UHF On Channel RF Output at the systems output power level. The translator takes the UHF on channel input and converts it to a combined IF output that connects to the exciter, which converts it to the desired UHF On Channel RF Output at the systems output power level.

The exciter/amplifier of the LX Series transmitter is of a Modular design and when a Module fails that module needs to be changed out with a replacement module. The failed module can then be sent back to Axcera for repair. Contact Axcera Customer Service Department at 724-873-8100 or fax to 724-873-8105, before sending in any module.

5.1 Module Replacement

Module replacement on the LX series products is a relatively simple process. All modules plug directly into the backplane board except for the power amplifier module, and in higher power units, the power supply and power amplifier modules, that plug into a blind mating connector. To replace a module, refer to the following procedure.

Loosen the two grip lock connectors, located on the front panel, at the top and bottom of the module, counterclockwise until the module releases. The Modulator, IF Processor, Upconverter and Controller/Power Supply can then be gently pulled from the unit. To remove the Driver/Power Amplifier Module in the exciter/amplifier chassis assembly, the two cables, Input and Output, connected to the rear of the

chassis must be removed. These two cables and also a 6/32" x 1/2" shipping screw, located between the two connectors, must be removed before the module will slide out.

After removal of the failed module, slide the replacement module in place and make certain it connects to the backplane board. If the replacement module is a driver/PA Module replace the two cables to the rear of the exciter/amplifier chassis assembly. The 6/32" x 1/2" shipping screw does not need to be replaced, it is only used during shipping. If the replacement module does not slide in easily, verify it is properly aligned in the nylon tracks, located on both the top and bottom of the module.

Note: Each Module has an assigned slot and will not fit properly or operate in the incorrect slot. Do not try to place a Module in the wrong slot as this may damage the slot or the connectors on the backplane board.

Each module has the name of the module on the front, bottom for identification and correct placement. The Modules are placed in the unit from left to right; (1) Receiver (in translator) or a Blank panel in a transmitter, (2) Modulator (in analog transmitter) or a Blank panel in a translator or digital transmitter, (3) IF Processor, (4) Upconverter, (5) Controller/Power Supply and (6) Power Amplifier.

5.1.1 Initial Test Set Up

Check that the RF output at the coupler is terminated into a dummy load rated at the output power level of the driver/transmitter/translator. While performing the alignment, refer to the Test Data Sheet for the system and compare the final readings from the

factory with the readings on each of the modules. The readings should be very similar. If a reading is way off, the problem is likely to be in that module.

Switch On the main AC for the system.

5.2 LX Series Exciter/Amplifier Chassis Assembly

The transmitter operates using baseband audio and video inputs. The translator uses the on channel UHF input.

NOTE: In systems that contain two exciters with an exciter switcher, both exciters must have audio and video inputs. Each exciter should be operated one at a time using the following procedure by first selecting Exciter A as the On Air exciter then selecting Exciter B as the On Air exciter. The Exciter Switcher must be in the manual mode.

On the LCD Display, located on the Controller/Power Supply Module, in Transmitter Set-Up, push the right button to switch the transmitter to Operate, STB will be displayed. The check of and the setup of the Audio and Video input levels are completed using the LCD Display and the front panel adjustments on the Modulator assembly. The level of the RF output includes adjustments of the drive level to the Power Amplifier and the adjustment of the linearity and phase predistortion to compensate for any nonlinear response of the Power Amplifier. The adjustments are located on the front panel of the IF Processor module.

5.2.1 (Optional) Receiver Module Assembly

NOTE: Not present in a Transmitter system.

Connect an on channel RF input to J12 the receiver RF input jack on the rear of exciter/driver assembly.

Verify that all LEDs located on the front panel of the Receiver are Green. The following details the meaning of each LED:

PLL 1 Fault (DS6) - Displays the status of the Local oscillator PLL

PLL 2 Fault (DS8) - Displays status of optional input frequency correcting PLL

DC on center conductor (DS4) - Displays whether or not DC is applied to the RF input center conductor*

***Caution: Do not hook up the RF input to any test equipment with the DC bias applied. Always move the jumper W1 on J2 on the UHF or VHF Preamplifier board to the Bias off position, between pins 2 & 3, to prevent possible damage to the test equipment.**

5.2.2 Modulator Module Assembly

NOTE: May not present in a Translator system.

The Modulator Assembly has adjustments for video levels and audio modulation levels, and other related parameters.

Connect an NTSC baseband video test signal input (1 Vpk-pk) to the transmitter video input jack J7 on the rear of the exciter. Jacks J7 and J17 are loop-through connected; the J17 jack can be used as a video source for another transmitter. Connect a baseband audio input (+10 dBm) to the balanced audio input terminal block TB02-1 [+], TB02-2 [-], and TB02-3 [ground] or, if stereo/composite audio is provided, connect it to BNC jack J3, the composite audio input jack. Verify that all LEDs located on the front panel of the Modulator are Green. The following details the meaning of each LED:

AURAL UNLOCK (DS5) – Red Indicates that 4.5 MHz Aural IF is unlocked from the Nominal 45.75 MHz visual IF.

VISUAL UNLOCK (DS6) – Red
Indicates that the Nominal 45.75 MHz visual IF is unlocked from the 10 MHz reference.

AUDIO OVER DEVIATION (DS4) – Red
Indicates that the input Audio level is too high. (± 75 kHz max)

VIDEO LOSS (DS1) – Red
Indicates that the input Video level is too low.

OVER MODULATION (DS3) – Red
Indicates that the input Video level is too high.

ALTERNATE IF (DS7) – Red
Indicates that an external Nominal 45.75 MHz IF is not present to the modulator.

10 MHz PRESENT (DS2) – Red
Indicates that an external 10 MHz reference is not present to the modulator.

Look at the front panel LCD meter on the Control/Power Supply Module Assembly. Set the LCD screen to the Modulator Details video output level screen, the screen indicates active video from 0 to 1 Vpk-pk. The normal video input level is 1 Vpk-pk on the front panel screen. If this reading is not at the proper level, the overall video level can be changed by adjusting the VIDEO LEVEL control R42 on the front panel of the Modulator to the 1 Vpk-pk level on the front panel screen.

NOTE: An NTSC or FCC composite signal should be used for video metering calibration.

Switch the LCD display to the Modulator Details screen that indicates the AUDIO DEVIATION (modulation level) of the signal up to ± 75 kHz.

MONO SET UP: The modulator was factory set for a ± 25 kHz deviation with a mono, balanced, audio input of +10 dBm. If the reading is not at the correct level, adjust the MONO Audio Gain pot R110, located on the front panel of the modulator, as necessary, to attain

the ± 25 kHz deviation on the front panel screen.

STEREO SET UP: The modulator was factory set for a ± 75 kHz deviation with a stereo, composite, audio input of 1 Vpk-pk. If this reading is not correct, adjust the STEREO Audio Gain pot R132, located on the front panel of the modulator, as necessary, for the ± 75 kHz deviation.

SECONDARY AUDIO SET UP: NOTE:
Remove any stereo or mono audio modulation input to the transmitter during the set up of the secondary audio. The modulator was factory set for a ± 15 kHz deviation with a secondary audio input of 1 Vpk-pk. If this reading is not correct, adjust the SAP/PRO Audio Gain pot R150, located on the front panel of the modulator, as necessary, for the ± 15 kHz deviation.

5.2.3 IF Processor Module Assembly

Verify that all red LEDs located on the IF Processor front panel are extinguished. The following details the meaning of each LED when illuminated:

- **Input Fault (DS1)** – Indicates that either abnormally low or no IF is present at the input of the IF Processor module.
- **ALC Fault (DS2)** – Indicates that the ALC circuit is unable to maintain the signal level requested by the ALC reference. This is normally due to excessive attenuation in the linearity signal path or the IF phase corrector signal path, or that switch SW1 is in the Manual ALC Gain position.
- **Mute (DS4)** – Indicates that a Mute command is present to the system.

Switch the transmitter to Standby. The ALC is muted when the transmitter is in Standby.

5.2.4 VHF/UHF Upconverter Module Assembly

Switch the transmitter to Operate. Verify that all LEDs located on the front panel of the Upconverter are Green. The following details the meaning of each LED:

PLL 1 Fault (DS1) - Displays the status of the 1 GHz PLL, Green locked or Red unlocked

PLL 2 Fault (DS2) - Displays status of the 1.1-1.9 GHz PLL, Green locked or Red unlocked

AGC Fault (DS7) - Displays status of AGC, Green normal or Red out of range

AGC Override (DS3) - Displays status of AGC cutback, either Green normal drive level, no cutback, or too much drive level to driver module, Red cutback.

Manual Gain (DS6) - Displays status of the control of the AGC level, either Green normal, AGC Adj. using R6 or Amber manual, Man Gain Adj. using R7.

5.2.5 Setting Up the Drive Level of the Transmitter Procedure

Setting the Manual AGC

Preset the front panel "Man Gain" pot on the Upconverter full **Counterclockwise**, and the Man/Auto Gain Switch to the **Left, Man**.

NOTE: The MAN/AUTO switch on this upconverter is the opposite polarity to the switch on the old upconverter for the LX transmitter.

Turn the transmitter to Operate, and slowly adjust the Man Gain pot until the desired % output power, as read on the LCD display, has been reached.

The Manual AGC is now set. Normal operation of the Transmitter is in the Auto AGC position.

Setting the Auto AGC

With the transmitter in **Standby**, preset the AGC pot on the Upconverter full **Counterclockwise**. Preset the AGC Cutback pot on the Upconverter full **Clockwise**. Move the Man/Auto Gain Switch on the Upconverter to the **Right, Auto**. Switch the transmitter to **Operate** and slowly adjust the AGC pot until the desired output power has been reached.

Monitor the output of the transmitter with a Spectrum Analyzer and turn the power up 1 dB higher than desired using the AGC pot. Enter the Transmitter Set-Up menu on the LCD Control Panel and step through the screens until the screen labeled "Inner Loop Gain" is reached. The inner loop is adjustable from 0-255. Use the + button to increase the Inner Loop Gain until the power on the spectrum analyzer just begins to decrease. Use the – button to decrease the inner loop gain by 10%. (If it begins to affect power at setting 160, drop it back down to 160-16=144, if it affects power at 100, drop it down by 10 to 90, etc...).

Slowly turn the AGC Cutback Pot **Counterclockwise** until the AGC Override light begins to flicker, and the output power begins to drop. Turn the pot **Clockwise** slightly, so the light just goes out and the power stabilizes. Turn the AGC pot down to get back to the desired % output power level.

The Auto AGC is now set. Normal operation of the Transmitter is in the Auto AGC position.

5.2.6 Changing the Transmitter Channel Procedure

NOTE: Depending on the new channel frequency, the bandpass filter may need to be retuned or replaced to achieve maximum output power.

Place the transmitter in Standby and go to the Set Up Menu, Transmitter Configuration Access Screen, on the LCD Display by pushing the down arrow on the default main screen and each succeeding screen until the Transmitter Set-Up Main Screen appears.

Transmitter Set-Up, Configuration Access Screen



Enter the Set-Up screens by pushing the ENT button. The following screen will appear.

Authorized Personnel Screen

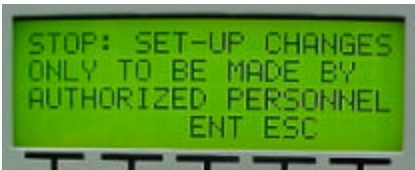

This screen of the transmitter notifies an operator that they are only to proceed if they are authorized to make changes to the transmitter's operation. This screen is implemented in transmitter software version 1.4 and above. Push the ENT button and step through the Set Up screens by pushing the Down Arrow button until the screen labeled "Upconverter CH xx" is reached, as shown below. The example below shows the Transmitter set to Channel 39.

Transmitter Set-up: Upconverter Channel Select Screen



The choices of this screen are to the standard UHF/VHF channels. The channel number should be blinking. To change the channel, hit the + button to

step through the channels until the desired channel is reached.

To select a 10kHz offset to the channel frequency, use the > button to move the curser to the LO frequency listed below the Channel number, and keep pressing the > button until the desired digit is blinking, and then use the + button to change the frequency.

Example:

Nominal LO frequency for Channel 39 = 0667.00 MHz. To generate a + offset, change the LO frequency to 0667.01 MHz. To generate a – offset, change the LO frequency to 0666.99 MHz.

A safeguard is added to the Set Up Menus in software version 2.5 and above. If a change is made to a screen within the Set Up Menu, as was just completed with the channel change, when you go to the next menu, by pushing the Down or Up Arrow, a screen appears that asks if you accept the change or want to return to the previous menu to reconsider the changes made. See the Accept or Return to previous Menu Screen shown below.

To accept the changes, the two buttons located under ACCEPT must be pushed simultaneously. To return to the previous Menu to make corrections, the two buttons located under the RETURN must be pushed simultaneously. Upon returning to the previous Menu the correct input must be entered and the above procedure repeated, this time accepting the changes.

Accept or Return to previous Menu
Screen



Pushing these two buttons together will accept the change.

Pushing these two buttons together will return you to the previous Menu.

Accepting the changes will put you back to the Main Set-Up Screen.

Calibration of Output and Reflected Power for transmitters up to 100W

NOTE: If your transmitter is higher than 100W with external Power Amplifiers then proceed to the next section.

Switch the transmitter to Standby and place the Upconverter into Manual Gain. Preset R205, the aural null pot on the Amp Control board, fully CCW. Adjust R204, the null offset pot on the Amp Control board, for 0% visual output. Perform the following adjustments with no aural present by removing the aural IF carrier jumper on the back of the chassis assembly. Connect a sync and black test signal to the video input jack of the test modulator. Switch the transmitter to Operate.

Next, set up the transmitter for the appropriate average output power level:

Example is for a 100 Watt Transmitter.

- Sync + black 0 IRE
setup/wattmeter=59.5 watts
- Sync + black 7.5 IRE
setup/wattmeter=54.5 watts

NOTE: The transmitter must have 40 IRE units of sync.

Adjust R202, visual calibration, on the Amp Control board for 100% on the front

panel LCD display in the % Visual Output position. (Examples of the screens are shown below).

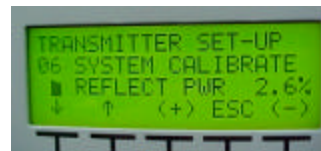

With the spectrum analyzer set to zero span mode, obtain a peak reference on the screen. Reconnect the aural carrier jumper on the rear of the chassis assembly. Turn the power adjust pot on the front panel until the original peak reference level is attained. Adjust R203 for a 100% aural power reading. Switch to the Visual Output Power position and adjust R205 (aural null pot) for 100% visual power.

To calibrate the reflected output power reading of the transmitter. Reduce the manual gain pot R3 to a 10% reading on the LCD front panel display in the % Output Power position. Place the transmitter in Standby. Remove the PA Module Sled. Remove the load from J4 on the (A4) Directional Coupler Board and switch the LCD Display screen to the Reflected Output Power position. Reinstall the PA Module. Switch the transmitter to operate. Adjust the reflected power calibration adjust pot R163 on the power amplifier module to a 10% reading. A reflected power fault should be present on the LCD Display. Reconnect the load to J4 in the module.

After this calibration is completed, move switch SW1 on the upconverter module to the Automatic AGC position. This is

the normal operating position for the switch. Adjust the ALC pot on the IF Processor is needed to attain 100% output power. Switch to Manual Gain (Manual AGC) and adjust the Manual Gain pot for 100 % output power. Switch the upconverter back to Automatic AGC.

This completes the channel change procedure for the LX Series transmitter with 100W or less output power.

If your transmitter is higher than 100W with external Power Amplifiers then proceed to the next section.

Calibration of Output and Reflected Power for transmitters above 100W with external Power Amplifiers

NOTE: If your transmitter is 100W or less in power, then use the previous procedure to recalibrate the system.

Calibration of the Transmitter Forward Output Power Level

Switch the transmitter to Standby and preset R51, the aural null pot on (A4) the visual/aural metering board, fully CCW. Switch the LO/Upconverter sled to Manual Gain. Adjust R48, the null offset pot on the visual/aural metering board, full CW. Adjust CCW until 0% visual output is displayed on the LCD Display in the System Visual Power position. Perform the following adjustments with no aural present by removing the jumper cable, the aural IF loop-through, that is connected on the rear of the exciter/driver chassis. Connect a sync and black test signal to the video input jack of the exciter/driver. Switch the transmitter to Operate.

Next, set up the transmitter for the appropriate average output power level using the Manual Gain pot on the LO/Upconverter sled:

Example is for a 1000 Watt transmitter.

- Sync + black 0 IRE
setup/wattmeter=595 watts
- Sync + black 7.5 IRE
setup/wattmeter=545 watts

NOTE: The transmitter must have 40 IRE units of sync.

Adjust R28, visual calibration, on the (A4) visual/aural metering board for .8V, at TB30-14 and TB30-12 return, on the exciter/driver assembly, then adjust display to read 100% on the front panel meter in the System Forward Power position. (Example of screen shown below).

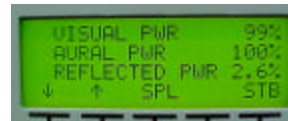

With the spectrum analyzer set to zero span mode, obtain a peak reference on the screen. Reconnect jumper cable on the rear of the exciter/driver. While in the Visual Output Power position, adjust L3 for a minimum visual power reading on the LCD display. Turn the power adjust pot on the LO/Upconverter sled front panel until the original peak reference level is attained. Peak L1 and C8 for a maximum aural power reading, then adjust R20 for .8V, at TB30-15 and TB30-12 return, on the exciter/driver assembly, then adjust LCD display for 100% system aural power reading. Switch to the Visual Output Power position and adjust R51 for 100% visual power on system LCD display. Switch the Upconverter to Auto and adjust the IF ALC Gain Pot for 100% Output. (Example of screen shown above).

NOTE: In Systems with the new frequency agile upconverters the following procedure must also be completed.

With the transmitter in **Standby**, preset the AGC pot on the Upconverter full **Counterclockwise**. Preset the AGC Cutback pot on the Upconverter full **Clockwise**. Move the Man/Auto Gain Switch on the Upconverter to the **Right, Auto**. Switch the transmitter to **Operate** and slowly adjust the AGC pot until the desired output power has been reached.

Monitor the output of the transmitter with a Spectrum Analyzer and turn the power up 1 dB higher than desired using the AGC pot. Enter the Transmitter Set-Up menu on the LCD Control Panel and step through the screens until the screen labeled "Inner Loop Gain" is reached. The inner loop is adjustable from 0-255. Use the + button to increase the Inner Loop Gain until the power on the spectrum analyzer just begins to decrease. Use the – button to decrease the inner loop gain by 10%. (If it begins to affect power at setting 160, drop it back down to 160-16=144, if it affects power at 100, drop it down by 10 to 90, etc....).

Slowly turn the AGC Cutback Pot **Counterclockwise** until the AGC Override light begins to flicker, and the output power begins to drop. Turn the pot **Clockwise** slightly, so the light just goes out and the power stabilizes. Turn the AGC pot down to get back to the desired % output power level.

The Auto AGC is now set. Normal operation of the Transmitter is in the Auto AGC position.

Calibration of the Transmitter Reflected Output Level

On the meter, in the Visual Power position, turn the power adjust pot to 25%. Move the Reflected cable on the

(A11) coupler to the unused "INC" port on the coupler. Then adjust R39 on (A4) the visual/aural metering board for a .2VDC, at TB30-13 and TB30-12 return, on the exciter/driver assembly. Next adjust the LED display for 25% reading in the System Reflected Power position. At this 25% reference power reading a reflected power fault should appear on the System Errors Menu. Turn the power adjust pot slightly CCW and the fault should be clearable on the System Error Menu. Turn the pot CW until the Fault appears. The reflected output power is now calibrated.

Switch the transmitter to Standby and move the Reflected power cable on the A11 Coupler back to the "Reflected Port".

When the transmitter utilizes external amplifier modules, the Forward Power readings for each of the amplifier modules will need to be readjusted to a 100% Forward Power reading. These amplifier readings can be found under the Transmitter Details Main Screen, by arrowing down to each Amp Set and each Module. These adjustments are completed after the System Forward and Reflected Powers have been calibrated to 100% power. (Example of screen shown below).



The Driver PA Assembly's Visual Calibration adjust pot should be adjusted for .8V AGC 1 on the Upconverter Details Screen found in the Transmitter Details Screens. After the Amplifiers are all calibrated for 100% Forward Power readings, the AGC 2 voltage found on the same Upconverter Details screen should be set for .9V. (Example of screen shown below).



Switch the transmitter to Operate and adjust the front panel power pot for a 100% visual power reading. Switch the LO/Upconverter to the Auto AGC position and adjust the ALC Gain adjust pot on the front of the IF Processor module for 100% visual power reading, if needed. (Example of screen shown below).



The Transmitter is ready for normal operation.

This completes the channel change procedure for the LX Series transmitter. If a problem occurred during the procedure, help can be found by calling Axcera field support at 724-873-8100.

5.2.7 Linearity Correction Adjustment

As shipped, the exciter was preset to include amplitude and phase pre-distortion. The pre-distortion was adjusted to approximately compensate the corresponding non-linear distortions of the Power Amplifier.

NOTE: On the IF processor board inside the module the correction enable/disable jumper W12 on J30 must be in the

Enable position, on pins 2 & 3. This is the normal operating position.

Set up a spectrum analyzer with 100 kHz resolution bandwidth and 100 kHz video bandwidth to monitor the intermodulation products of the RF output signal of the Power Amplifier.

A typical red field spectrum is shown in Figure 5-1. There are three Linearity Corrector stage adjustments located on the front panel of the IF Processor Module. The adjustments are threshold settings that are adjusted as needed to correct for any amplitude or phase intermod problems. Adjust the top linearity correction adjustment R211 threshold cut in for the in phase amplitude distortion pre-correction that is needed. Next adjust the middle linearity correction adjustment R216 threshold cut in also for the in phase amplitude distortion pre-correction that is needed. Finally adjust the bottom linearity correction adjustment R231 threshold cut in for the quadrature phase distortion pre-correction that is needed. The above pots are adjusted for the greatest separation between the peak visual carrier and the intermod products. **NOTE:** These pots affect many other video parameters, so care should be taken when adjusting the linearity correction.

Figure 5-1. Typical Red Field Spectrum



5.2.8 Frequency Response Delay Equalization Adjustment

NOTE: Perform the following procedure only if a frequency response delay equalization problem is suspect.

The procedure for performing a frequency response delay equalization adjustment for the transmitter is done at IF and is described in the following steps:

The center frequency for the first stage is 45 MHz. Adjust R103, the top frequency response equalizer pot, located on the front panel of the IF Processor Module, for the best depth of frequency response correction at 45 MHz.

The center frequency for the second stage is 42 MHz. Adjust R106, the middle frequency response equalizer pot, located on the front panel of the IF Processor Module, for the best depth of frequency response correction at 42 MHz.

The center frequency for the second stage is 43.5 MHz. Adjust R274, the bottom frequency response equalizer pot, located on the front panel of the IF Processor Module, for the best depth of frequency response correction at 43.5 MHz.

After the three delay attenuation equalizers have been adjusted, fine tune, as needed, for the best frequency response across the channel.

5.2.9 Calibration of Output Power and Reflected Power of the transmitter

NOTE: Perform the following procedure only if the power calibration is suspect.

Switch the transmitter to Standby and place the Upconverter into Manual Gain. Preset R205, the aural null pot on the Amp Control board, fully CCW. Adjust R204, the null offset pot on the Amp Control board, for 0% visual output. Perform the following adjustments with

no aural present by removing the aural IF carrier jumper on the back of the chassis assembly. Connect a sync and black test signal to the video input jack of the test modulator. Switch the transmitter to Operate.

Next, set up the transmitter for the appropriate average output power level:

Example is for a 100 Watt Transmitter.

- Sync + black 0 IRE
setup/wattmeter=59.5 watts
- Sync + black 7.5 IRE
setup/wattmeter=54.5 watts

NOTE: The transmitter must have 40 IRE units of sync.

Adjust R202, visual calibration, on the Amp Control board for 100% on the front panel LCD display in the % Visual Output position.

With the spectrum analyzer set to zero span mode, obtain a peak reference on the screen. Reconnect the aural carrier jumper on the rear of the chassis assembly. Turn the power adjust pot on the front panel until the original peak reference level is attained. Adjust R203 for a 100% aural power reading. Switch to the Visual Output Power position and adjust R205 (aural null pot) for 100% visual power.

To calibrate the reflected output power reading of the transmitter. Reduce the manual gain pot R3 to a 10% reading on the LCD front panel display in the % Output Power position. Place the transmitter in Standby. Remove the PA Module Sled. Remove the load from J4 on the (A4) Directional Coupler Board and switch the LCD Display screen to the Reflected Output Power position. Reinstall the PA Module. Switch the transmitter to operate. Adjust the reflected power calibration adjust pot R163 on the power amplifier module to a 10% reading. A reflected power fault

should be present on the LCD Display.
Reconnect the load to J4 in the module.

After this calibration is completed, move switch SW1 on the upconverter module to the Automatic AGC position. This is the normal operating position for the switch. Adjust the ALC pot on the IF Processor is needed to attain 100% output power. Switch to Manual Gain (Manual AGC) and adjust the Manual Gain pot for 100 % output power. Switch the upconverter back to Automatic AGC.

5.3 (A9) Bandpass Filter Assembly

NOTE: If your system contains a Teracom manufactured tunable filter assembly, refer to the manufacturers manual included with the filter for instructions on tuning and ignore the following sections on the Axcera manufactured Bandpass and Trap Filter Assemblies.

NOTE: The bandpass filter and the (optional) trap filter are factory swept to the proper channel and should not be tuned without the proper equipment. Do not attempt to tune the filters without a sweep generator or, preferably, a network analyzer. If tuning is thought to be required, consult with the Axcera Field

Support Department before attempting to tune the filters.

The bandpass filter is made of aluminum waveguide and has five resonant cavities. The filter has five bolts for tuning adjustments, three located in the middle on the left and two on the right, and four or six rods on the front of the bandpass filter, depending upon the channel, for coupling adjustments between the sections. The bandpass filter also utilizes two integral traps at -4.5 MHz and +9 MHz from F_V at the top and bottom, respectively, of the left-hand side of the bandpass filter, looking from the rear of the cabinet. Figure 5-2 shows the location of the bolts used for making tuning adjustments.

To tune the filter, connect a sweep signal to the input of the filter and adjust the five tuning bolts for a 6-MHz bandwidth and a flat-frequency response across the desired band.

NOTE: The bandpass ripple should be ≤ 0.25 dB. The 6-MHz band should also have a minimum of 20 dB return loss across the pass band.

See Table 5-1 for typical bandpass values.

Table 5-1. Typical Bandpass Values

FREQUENCY	INSERTION LOSS (dB)	RETURN LOSS (dB)
$F_V - 4.5$	≥ 35	
$F_V - 0.5$		≥ 20
F_V	≤ 0.6	≥ 20
F_a	≤ 0.6	≥ 20
$F_V + 8.08$	≥ 15	
$F_V - 9$	≥ 30	
$2F_V$	≥ 30	

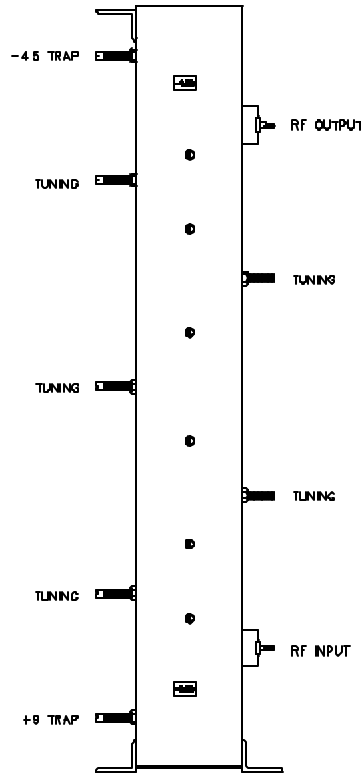

Figure 5-2. Bandpass Filter

5.4 (A10) UHF Trap Filter Assembly

The Traps on the output Trap Filter are labeled with their Center Frequency relative to the Frequency of the Carrier. (For Example: The Traps labeled -4.5 MHz are tuned for a Center Frequency of 4.5 MHz Lower than the Frequency of the Visual Carrier.) The first section of the Trap Filter filters out the Visual Carrier plus 9 MHz ($f_v + 9$ MHz). The second and fourth sections work together to filter out the lower spurious product ($f_v - 4.5$ MHz). The third section is tuned to remove the ($f_v + 8.08$). The output of the Trap Filter is an "N" Type Connector. The Trap Sections have been factory tuned and should not need major adjustments. The Trap Filter is comprised of four trap sections connected to the main transmission line. The Trap Sections are Reflective Notches, adjustable across the entire UHF Frequency Band. The electrical length of the Outer Sleeve and the Center Rod of the Notch can be adjusted

to Tune the Notch Frequency. The Depth of the Notch is set by the gap between the Center Conductor of the Trap Section and the Center Conductor of the Main Line. Tight Coupling makes a Deep Notch, while Loose Coupling makes a Shallow Notch.

FINE TUNING of the Notches Center Frequency can be accomplished with the Tuning Bolts located on the side of the Filter Section. Loosen the nut locking the Bolt in place and adjust the Bolt to change the Frequency of the Notch. Monitor the output of the Transmitter with a Spectrum Analyzer and Null the Distortion Product with the Bolt. Red Field is a good Video Test Signal to use to see the +8.08 MHz Product. Tighten the nut when the tuning is completed. Hold the bolt in place with a screwdriver as the nut is tightened to prevent it from slipping.

MAJOR TUNING, such as changing the Notch Depth or moving the Notch Frequency more than 1 MHz, the Outer Conductor and the Center Conductor of the Trap Section must both be moved. This requires a RF Sweep Generator to accomplish. Apply the Sweep signal to the Input of the Trap Filter and monitor the Output. Loosen the Clamp holding the Outer Conductor in place and make the length longer to Lower the frequency of the Notch or shorter to Raise the frequency of the Notch. Loosen the Center Conductor with an Allen Wrench and move it Deeper for a Lower Frequency Notch or out for a Higher Frequency Notch. These adjustments must both be made to change the Notch Frequency. Moving only the Center Conductor or the Outer Conductor will affect the Notch Depth in addition to the Center Frequency. The variable that is being adjusted with this procedure is the length of the Center Conductor inside the Trap Filter. The gap between the Trap and the Main Line should not be changed. Moving only the Inner or the Outer Conductors by itself will affect the Gap and the Notch depth. To affect the Notch Depth Only, both sections will have to be moved. The Notch Depth is controlled by the Gap between the Center Conductor and the Trap Section. This Gap also has an effect on the Center Frequency. To Deepen the Notch, Shorten the Outer Conductor and pull the Center Conductor Out until the Notch is back in the same place. Move the Sections in the opposite direction to make a Shallow Notch.

NOTE: The Trap Filter is typically adjusted for a notch depth of 10 dB.

5.4.1 The Effects of Tuning the Output Trap Filter

Lengthening Outer Conductor Only - Notch Frequency Up, Shallower Notch.

Shortening Outer Conductor Only - Notch Frequency Down, Deeper Notch.

Inserting Inner Conductor Deeper - Notch Frequency Down, Deeper Notch.

Inserting Less Inner Conductor - Notch Frequency Up, Shallower Notch.

Tuning Bolt In - Notch Frequency Down.

Tuning Bolt Out - Notch Frequency Up.

Moving both Inner and Outer Conductors to keep the Same Gap inside - Center Frequency Moves, Notch Stays the Same.

After tuning has been completed, tighten the Clamp and the Allen Screws that hold the Conductors. Use the Fine Tuning Bolts to bring the Frequency In. The Final Tuning Adjustments should be completed with the Transmitter driving the Output Trap Filter for at least one hour to allow for warm-up drift.

The Transmitter is ready for normal operation.

NOTE: In Dual Exciter Systems, with an exciter switcher, repeat the above procedure with Exciter B selected as the On Air Exciter. The exciter switcher must be in manual.

This completes the detailed alignment procedures for the LX Series transmitter.

If a problem occurred during the alignment, help is available by calling Axcera field support at (724) 873-8100.

APPENDIX A

LX SERIES ANALOG
SYSTEM SPECIFICATIONS

Low Power Transmitter 10W-6kW



Designed to provide broadcasters with a product that will meet their needs like no other solution on the market, this new low to medium power transmitter line uses the latest LDMOS devices for broadband operation across the entire UHF band. This allows users to minimize spare parts stock, which is especially important to group owners and networks, and also enables simple and inexpensive channel changes.

The very compact and completely modular design uses a chassis/backplane configuration with parallel amplifier and power supply modules that can be removed and replaced while the transmitter is on the air. Additionally, the Innovator LX series was designed to be field upgradable to digital operation.

Configurations are available in power levels from 10 watts to 6 kilowatts analog and up to 3 kilowatts DTV, and all are manufactured in the USA by Axcera - *The RF Experts*.

Low Power Transmitter 10W - 6kW

Visual Performance

Frequency Range	470 to 806 MHz
Carrier Stability (<i>Transmitters</i>)	
Standard	±1 kHz
Optional w/PFC	±350 Hz
Frequency Translation Stability (<i>Translators</i>)	
Standard	±1 kHz
Optional w/PFC	±350 Hz
Regulation of RF Output Power	3%
Output Variation (<i>Over 1 Frame</i>)	2%
Sideband Response	
-1.25 MHz and below	-20 dB
-0.75 to -0.5 MHz	+0.5 db, -2 dB
-0.5 to +3.58 MHz	±0.5 dB
+3.58 MHz to +4.18 MHz	+0.5, -1.0 dB
Freq Response vs. Brightness	±0.5 dB
Visual Modulation Capability	1%
Differential Gain	5%
Incidental Phase Modulation	±3°
Linearity (<i>Low Frequency</i>)	5%

Visual Performance (*continued*)

Differential Phase	±3°
Signal-to-Noise Ratio	55 dB
2t K-Factor	2%
Noise Factor (<i>Translators</i>)	5 dB (<i>Max</i>)
w/Input Preamp	3 dB (<i>Max</i>)
Input Dynamic Range (<i>Translators</i>)	-60 dB to -15 dBm
w/Input Preamp	-75 dBm to -30 dBm
Env. Delay (<i>Transmitters</i>)	Per FCC Standard
Video Input (<i>Transmitters</i>)	75 ohms (Loop through)
Harmonics	-60 dB or better
Intermodulation Products	-52 dB or better
Spurious (<i>±3 MHz from channel edge</i>)	
100W and lower	-50dB or better
Greater than 100W	-60dB or better

Aural Performance

Frequency Deviation Capability (<i>Transmitters</i>)	±75 kHz
Distortion	0.5%
FM Noise	-60 dB
AM Noise	-55 dB
Aural to Visual Separation	4.5 MHz ± 100Hz
Composite Audio Input (<i>Multi-channel sound Transmitters</i>)	
Input Level	1V peak, nominal
Input Impedance	75 ohms, unbalanced
Frequency Range	
±0.1 dB response	50 Hz to 50 kHz
±0.5 dB response	30 Hz to 120 kHz
Monaural Audio Input (<i>Transmitters</i>)	
Input Level	0 to +10 dBm
Input	600 ohms, balanced
Freq Range (<i>±0.5 dB resp.</i>)	30 Hz to 15 kHz
Pre-emphasis	75µs
Subcarrier Input (<i>Transmitters</i>)	
Input Level	1V peak, nominal
Input Impedance	75 ohms, unbalanced
Freq Range (<i>±0.5 dB resp.</i>)	20 kHz to 120 kHz

General

Model Number*	LU10Ax	LU100Ax	LU250Ax	LU500Ax	LU1000Ax	LU2000Ax	LU3000Ax	LU4000Ax	LU5000Ax	LU6000Ax
Power Output (<i>Watts</i>)										
Visual (<i>Peak</i>)	10	100	250	500	1000	2000	3000	4000	5000	6000
Aural (<i>Avg.</i>)	1	10	25	50	100	200	300	400	500	600
Output Connector	N	N	7/8" EIA	7/8" EIA	7/8" EIA	7/8" EIA	3 1/8" EIA	3 1/8" EIA	3 1/8" EIA	3 1/8" EIA
Power Consumption (<i>Watts</i>)	250	675	1100	1900	3500	6700	10,250	13,500	16,700	19,900
Input Power										
Line Voltage (<i>Volts</i>)	117/230 ±10%		230 ± 10%							
Power Requirements	Single Phase, 50 or 60 Hz									
Size (<i>H x W x D</i>)	8.75"x19"x23" <i>(Chassis Only)</i>		55"x22"x34"				76"x22"x34"		76"x44"x34"	
Weight (<i>lbs.</i>)	45	45	340	360	400	550	700	1030	1180	1330
Operational Temperature Range	0 to +50°, derate 2°C/1000 ft.									
Maximum Altitude ³	8500 feet (2600m) AMSL									
Operational Humidity Range	0% to 95% non-condensing									
RF Load Impedance	50 Ω									

* For transmitters use "T" suffix, translators use "L" suffix (ex. LU100AT - 100W Transmitter)

Specifications published here are current as of the date of publication of this document. Because we are continuously improving our products, Axcera reserves the right to change specifications without prior notice. At any time, you may verify product specifications by contacting our office. Axcera views its patent portfolio as an important corporate asset and vigorously enforces its patents. Products or features contained herein may be covered by one or more U.S. or foreign patents.

APPENDIX B

DRAWINGS AND PARTS LISTS

Innovator LX Series Analog System

LX Series Analog Transmitter/Translator System Interconnect 1303478

(6 kW Transmitter/Translator) 1304311

Filter Metering Assembly (Used in 10W-100W Systems)

Assembly Drawing 1303566

Parts List 1303566

(Optional) Single Channel Exciter Switcher Tray, 110VAC

Interconnect 1305739

Chassis Assembly, 110 VAC Exciter, V2, LX Series

Interconnect 1304064

OR Chassis Assembly, 220 VAC Exciter, V2, LX Series

Interconnect 1304064

Backplane Board, V2, LX Series

Schematic 1304049

NOTE: Your Translator will contain one of the following Receiver Assemblies as indicated.**Receiver Assembly, VHF Low Band (Part of Translator System)**

Interconnect 1304005

Block Diagram 1304004

Receiver Assembly, VHF High Band (Part of Translator System)

Interconnect 1304005

Block Diagram 1304004

Receiver Assembly, UHF (Part of Translator System)

Interconnect 1304005

Block Diagram 1304004

NOTE: Your Receiver Amplifier Assembly will contain some of the following Boards and Assemblies as indicated.

VHF High Band Preamplifier Board, (Used in VHF HB Receiver Assembly 1304001)

Schematic 1303901

IF ALC Board, (Used in VHF LB Receiver Assembly 1304000, VHF HB Receiver Assembly 1304001 and UHF Receiver Assembly 1304002)

Schematic 1304011

VHF Mixer/PLL Board, (Used in VHF LB Receiver Assembly 1304000 and VHF HB Receiver Assembly 1304001)

Schematic 1304015

UHF Mixer/PLL Board, (Used in UHF Receiver Assembly 1304002)

Schematic 1304023

UHF Preamplifier Board, (Used in UHF Receiver Assembly 1304002)

Schematic 1304091

VHF Low Band Preamplifier Board, (Used in VHF LB Receiver Assembly 1304000) Schematic	1305214
IF Processor Assembly	
Assembly Drawing	1301938
IF Processor Board Schematic	1301983
VHF/UHF Upconverter Assembly	
Block Diagram.....	1303830
Interconnect.....	1303831
Downconverter Board Assembly Schematic	1303836
First Conversion Board, LX Series Schematic	1303840
L-Band PLL Board, LX Series Schematic	1303848
Upconverter Control Board, LX Series Schematic	1304761
Control/Power Supply Assembly, 110 VAC	
Block Diagram.....	1303889
Interconnect.....	1302062
OR Control/Power Supply Assembly, 220 VAC	
Block Diagram.....	1303889
Interconnect.....	1302062
Control Board Schematic	1302023
Power Protection Board Schematic	1302839
Switch Board Schematic	1527-3406
NOTE: Your Transmitter will contain one of the following Power Amplifier or Driver Power Amplifier Assemblies as indicated.	
Power Amplifier Assembly, (Used as the final PA in 10-100 Watt Systems or as the Driver PA in Systems above 2kW)	
Block Diagram.....	1303850
Interconnect.....	1303814
NOTE: Your Power Amplifier or Driver Power Amplifier Assembly will contain some of the following Boards and Assemblies as indicated.	
Coupler Board Assembly, (Used in Driver PA Assemblies 1303771 and 1303874) Schematic	1227-3316
Coupler Board Assembly, (Used in PA Assembly 1303770)	

Schematic 1303152

Amplifier Control Board, (Used in PA Assembly 1303770 and Driver PA Assemblies
1303771 and 1303874)

Schematic 1303683

1 Watt Module Assembly, (Used in PA Assembly 1303770 and Driver PA Assemblies
1303771 and 1303874)
Contains a 1 Watt UHF Amplifier Board (1302761).

1 Watt UHF Amplifier Board, (Used in PA Assembly 1303770 and Driver PA Assemblies
1303771 and 1303874)

Schematic 1302762

40W UHF Module, Tested, (Used in PA Assembly 1303770 and Driver PA Assembly
1303771)
Made from a TFS 40W UHF Module, Stork (51-5379-308-00).

TFS 40W UHF Module, Stork, (Used in PA Assembly 1303770 and Driver PA Assembly
1303771)

Schematic 51-5379-308-00 WSP

RF Module Pallet, Philips, (Used in PA Assembly 1303770 and Driver PA Assembly
1303874)
Made from a RF Module Pallet w/o Transistors (1152336).

RF Module Pallet w/o Transistors, (Used in PA Assembly 1303770 and Driver PA
Assembly 1303874)

Schematic 51-5379-309-00 WSP

APPENDIX C
TRANSMITTER LOG SHEET

DESCRIPTION OF PARAMETER	TRANSMITTER READING FROM LCD DISPLAY					
DATE READINGS TAKEN						
Model Number						
Code Version						
Firmware Number						
OUTPUT MEASUREMENTS						
% VISUAL POWER						
% AURAL POWER						
RECEIVER DETAILS	NOT USED WITH TRANSMITTER					
AFC 1 LEVEL						
PLL 1 CIRCUIT						
ALC INPUT						
FAULT AT						
MODULATOR DETAILS	MAY NOT BE USED WITH TRANSLATOR					
PLL CIRCUIT						
OUTPUT LEVEL						
AURAL DEVIATION						
CW INPUT						
CALL SIGN						
IF PROCESSOR DETAILS						
INPUT SIGNAL STATE						
MODULATION						
INPUT IF						
DLC CONTROL LOCK						
ALC LEVEL						
ALC MODE						
UPCONVERTER DETAILS						
AFC 1 LEVEL						
AFC 2 LEVEL						
CODE VERSION						
PLL 1 CIRCUIT						
PLL 2 CIRCUIT						
AGC 1 LEVEL						
AGC 2 LEVEL						
INT. 10 MHz						
SYSTEM CONTROL DETAILS						
Power Supply Enable For						

DESCRIPTION OF PARAMETER	TRANSMITTER READING FROM LCD DISPLAY					
DRIVER AND PA DETAILS						
POWER SUPPLY STATE, 32V						
FORWARD POWER						
REFLECTED POWER						
AMP 1 CURRENT						
AMP 2 CURRENT						
TEMPERATURE						
CODE VERSION						
PA HAS OPERATED FOR						
EXT. PA AMPLIFIER MODULES	ONLY IN HIGH POWER SYSTEMS					
AMP SET 1 MODULE 1	Will indicate Amp Set and Module within the Set. Will step through each Set and Module.					
POWER SUPPLY VOLTAGE, 32V						
32V SUPPLY						
FORWARD POWER						
REFLECTED POWER						
AMP CURRENT 1						
AMP CURRENT 2						
AMP CURRENT 3						
AMP TEMPERATURE						
CODE VERSION						
PA HAS OPERATED FOR						
AMP SET 1 MODULE 2						
POWER SUPPLY VOLTAGE, 32V						
32V SUPPLY						
FORWARD POWER						
REFLECTED POWER						
AMP CURRENT 1						
AMP CURRENT 2						
AMP CURRENT 3						
AMP TEMPERATURE						
CODE VERSION						
PA HAS OPERATED FOR						
AMP SET 1 MODULE 3						
POWER SUPPLY VOLTAGE, 32V						
32V SUPPLY						
FORWARD POWER						
REFLECTED POWER						
AMP CURRENT 1						
AMP CURRENT 2						
AMP CURRENT 3						
AMP TEMPERATURE						
CODE VERSION						
PA HAS OPERATED FOR						

DESCRIPTION OF PARAMETER	TRANSMITTER READING FROM LCD DISPLAY					
AMP SET 1 MODULE 4						
POWER SUPPLY VOLTAGE, 32V						
32V SUPPLY						
FORWARD POWER						
REFLECTED POWER						
AMP CURRENT 1						
AMP CURRENT 2						
AMP CURRENT 3						
AMP TEMPERATURE						
CODE VERSION						
PA HAS OPERATED FOR						
AMP SET 2 MODULE 1						
POWER SUPPLY VOLTAGE, 32V						
32V SUPPLY						
FORWARD POWER						
REFLECTED POWER						
AMP CURRENT 1						
AMP CURRENT 2						
AMP CURRENT 3						
AMP TEMPERATURE						
CODE VERSION						
PA HAS OPERATED FOR						
AMP SET 2 MODULE 2						
POWER SUPPLY VOLTAGE, 32V						
32V SUPPLY						
FORWARD POWER						
REFLECTED POWER						
AMP CURRENT 1						
AMP CURRENT 2						
AMP CURRENT 3						
AMP TEMPERATURE						
CODE VERSION						
PA HAS OPERATED FOR						
AMP SET 2 MODULE 3						
POWER SUPPLY VOLTAGE, 32V						
32V SUPPLY						
FORWARD POWER						
REFLECTED POWER						
AMP CURRENT 1						
AMP CURRENT 2						
AMP CURRENT 3						
AMP TEMPERATURE						
CODE VERSION						
PA HAS OPERATED FOR						

DESCRIPTION OF PARAMETER	TRANSMITTER READING FROM LCD DISPLAY					
AMP SET 2 MODULE 4						
POWER SUPPLY VOLTAGE, 32V						
32V SUPPLY						
FORWARD POWER						
REFLECTED POWER						
AMP CURRENT 1						
AMP CURRENT 2						
AMP CURRENT 3						
AMP TEMPERATURE						
CODE VERSION						
PA HAS OPERATED FOR						
AMP SET 3 MODULE 1						
POWER SUPPLY VOLTAGE, 32V						
32V SUPPLY						
FORWARD POWER						
REFLECTED POWER						
AMP CURRENT 1						
AMP CURRENT 2						
AMP CURRENT 3						
AMP TEMPERATURE						
CODE VERSION						
PA HAS OPERATED FOR						
AMP SET 3 MODULE 2						
POWER SUPPLY VOLTAGE, 32V						
32V SUPPLY						
FORWARD POWER						
REFLECTED POWER						
AMP CURRENT 1						
AMP CURRENT 2						
AMP CURRENT 3						
AMP TEMPERATURE						
CODE VERSION						
PA HAS OPERATED FOR						
AMP SET 3 MODULE 3						
POWER SUPPLY VOLTAGE, 32V						
32V SUPPLY						
FORWARD POWER						
REFLECTED POWER						
AMP CURRENT 1						
AMP CURRENT 2						
AMP CURRENT 3						
AMP TEMPERATURE						
CODE VERSION						
PA HAS OPERATED FOR						

DESCRIPTION OF PARAMETER	TRANSMITTER READING FROM LCD DISPLAY					
AMP SET 3 MODULE 4						
POWER SUPPLY VOLTAGE, 32V						
32V SUPPLY						
FORWARD POWER						
REFLECTED POWER						
AMP CURRENT 1						
AMP CURRENT 2						
AMP CURRENT 3						
AMP TEMPERATURE						
CODE VERSION						
PA HAS OPERATED FOR						
AMP SET 4 MODULE 1						
POWER SUPPLY VOLTAGE, 32V						
32V SUPPLY						
FORWARD POWER						
REFLECTED POWER						
AMP CURRENT 1						
AMP CURRENT 2						
AMP CURRENT 3						
AMP TEMPERATURE						
CODE VERSION						
PA HAS OPERATED FOR						
AMP SET 4 MODULE 2						
POWER SUPPLY VOLTAGE, 32V						
32V SUPPLY						
FORWARD POWER						
REFLECTED POWER						
AMP CURRENT 1						
AMP CURRENT 2						
AMP CURRENT 3						
AMP TEMPERATURE						
CODE VERSION						
PA HAS OPERATED FOR						
AMP SET 4 MODULE 3						
POWER SUPPLY VOLTAGE, 32V						
32V SUPPLY						
FORWARD POWER						
REFLECTED POWER						
AMP CURRENT 1						
AMP CURRENT 2						
AMP CURRENT 3						
AMP TEMPERATURE						
CODE VERSION						
PA HAS OPERATED FOR						

DESCRIPTION OF PARAMETER	TRANSMITTER READING FROM LCD DISPLAY					
AMP SET 4 MODULE 4						
POWER SUPPLY VOLTAGE, 32V						
32V SUPPLY						
FORWARD POWER						
REFLECTED POWER						
AMP CURRENT 1						
AMP CURRENT 2						
AMP CURRENT 3						
AMP TEMPERATURE						
CODE VERSION						
PA HAS OPERATED FOR						
AMP SET 5 MODULE 1						
POWER SUPPLY VOLTAGE, 32V						
32V SUPPLY						
FORWARD POWER						
REFLECTED POWER						
AMP CURRENT 1						
AMP CURRENT 2						
AMP CURRENT 3						
AMP TEMPERATURE						
CODE VERSION						
PA HAS OPERATED FOR						
AMP SET 5 MODULE 2						
POWER SUPPLY VOLTAGE, 32V						
32V SUPPLY						
FORWARD POWER						
REFLECTED POWER						
AMP CURRENT 1						
AMP CURRENT 2						
AMP CURRENT 3						
AMP TEMPERATURE						
CODE VERSION						
PA HAS OPERATED FOR						
AMP SET 5 MODULE 3						
POWER SUPPLY VOLTAGE, 32V						
32V SUPPLY						
FORWARD POWER						
REFLECTED POWER						
AMP CURRENT 1						
AMP CURRENT 2						
AMP CURRENT 3						
AMP TEMPERATURE						
CODE VERSION						
PA HAS OPERATED FOR						

DESCRIPTION OF PARAMETER	TRANSMITTER READING FROM LCD DISPLAY					
AMP SET 5 MODULE 4						
POWER SUPPLY VOLTAGE, 32V						
32V SUPPLY						
FORWARD POWER						
REFLECTED POWER						
AMP CURRENT 1						
AMP CURRENT 2						
AMP CURRENT 3						
AMP TEMPERATURE						
CODE VERSION						
PA HAS OPERATED FOR						
AMP SET 6 MODULE 1						
POWER SUPPLY VOLTAGE, 32V						
32V SUPPLY						
FORWARD POWER						
REFLECTED POWER						
AMP CURRENT 1						
AMP CURRENT 2						
AMP CURRENT 3						
AMP TEMPERATURE						
CODE VERSION						
PA HAS OPERATED FOR						
AMP SET 6 MODULE 2						
POWER SUPPLY VOLTAGE, 32V						
32V SUPPLY						
FORWARD POWER						
REFLECTED POWER						
AMP CURRENT 1						
AMP CURRENT 2						
AMP CURRENT 3						
AMP TEMPERATURE						
CODE VERSION						
PA HAS OPERATED FOR						
AMP SET 6 MODULE 3						
POWER SUPPLY VOLTAGE, 32V						
32V SUPPLY						
FORWARD POWER						
REFLECTED POWER						
AMP CURRENT 1						
AMP CURRENT 2						
AMP CURRENT 3						
AMP TEMPERATURE						
CODE VERSION						
PA HAS OPERATED FOR						

DESCRIPTION OF PARAMETER	TRANSMITTER READING FROM LCD DISPLAY					
AMP SET 6 MODULE 4						
POWER SUPPLY VOLTAGE, 32V						
32V SUPPLY						
FORWARD POWER						
REFLECTED POWER						
AMP CURRENT 1						
AMP CURRENT 2						
AMP CURRENT 3						
AMP TEMPERATURE						
CODE VERSION						
PA HAS OPERATED FOR						

NOTE: The previous Log Sheet readings can be taken from the System Details Screen, Menu 30-1, on the 4 x 20 Display located on the front of the Control & Monitoring/Power Supply Module.