

PET Immune SAW PIR Motion Sensors Installation Sheet

Description

This is the Installation Sheet for SAW PIR and PET Immune Motion Sensors. See Table 1.

Table 1: Motion Sensors

60-807-95R	Pet Immune SAW PIR Motion Sensor
60-807-01-95R	Pet Immune SAW PIR Motion Sensor with Lithium Battery.
60-807-02-95R	Pet Immune SAW PIR Motion Sensor with 1.5 V Lithium Batteries.

A motion sensor (passive-infrared or PIR) detects movement within a specific area by sensing the infrared energy emitted from a body as it moves across the sensor's field of view. When this motion is detected, the sensor transmits an alarm signal to the control panel.

Figure 1: Pet Immune SAW PIR Motion Sensors

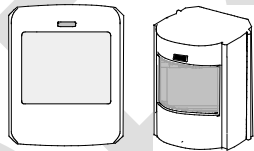

Use these motion sensors to protect locations where door/window sensors are impractical or not needed. For example, use a motion sensor to protect large areas or open floor plans. Motion sensors also provide backup protection for door/window sensors.

The Pet Immune SAW PIR 60-807 utilizes advanced signal processing, a new custom designed lens, and a new custom designed sensing element. The combination of these improvements provides false alarm immunity for pets with a combined weight of up to 40 pounds while still providing superior human catch performance.

These wireless motion sensors include the following features:

- 35 by 40 ft. (10.6 m by 12 m) coverage area.
- Three minute transmitter lockout time after an alarm that helps extend battery life.
- Cover-activated tamper (optional wall-activated tamper is included).

- Supervisory signals transmitted every 64 minutes to the control panel.
- Sensor low battery reports (trouble) to the control panel.
- Field-selectable sensitivity options.

Installation

Installation Guidelines

- Temporarily place the sensor in its intended mounting location. Program and final test the sensor before permanently mounting it.
- If possible, locate sensors within 100 ft. (30.5 m) of the panel. While a transmitter may have a range of 500 ft. (152 m) or more out in the open, the environment at the installation site can have a significant effect on transmitter range. Sometimes a change in sensor location can help overcome adverse wireless conditions.
- The recommended mounting height is 7 1/2 ft.
- Position the sensor to protect an area where an intruder would be most likely to walk across the detection pattern. See Figure 2.

Figure 2: Overhead Detection Path

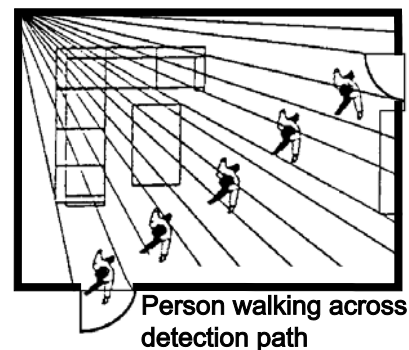

- Mount the motion sensor on a rigid surface which is free from vibrations.
- Do not mount the sensor near duct work or other large metallic surfaces which may affect the RF signals (see RF Testing). Actual acceptable transmitter range should be verified for each installation.

- Mount the sensor permanently on a flat wall or in a corner. Do not set it on a shelf.
- Windows should be closed in any area which has an armed motion sensor.
- The sensor must be incline-mounted at a mounting height of 7.5 ft. See Figure 3.

Figure 3: Wall Mount Options

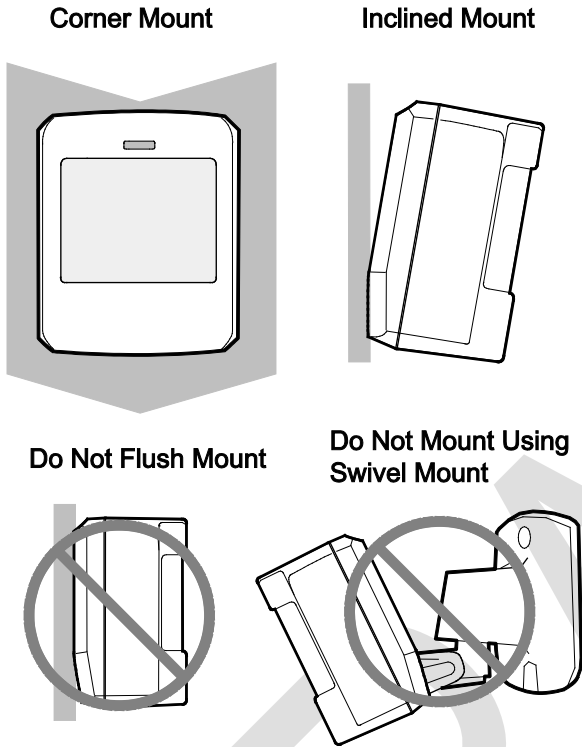

- Room temperature must be kept between 60° and 120°F (16° and 49° C).
- Position the sensor so it faces a solid reference point, like a wall.

Programming

Refer to the panel documentation for information on programming the sensor into the panel.

To Trip the Sensor

1. Set the panel to program mode.
2. Proceed to the Learn Sensors menu.
3. Remove the PIR from its mounting plate (activating the tamper switch).
4. Select the appropriate sensor group and number.
5. Exit the panel's programming mode.
6. Return the PIR to its mounting plate.

Final Testing

Final testing should be done to verify radio signal integrity and confirm control panel programming and response. The actual transmitter range can be determined by performing a sensor test as follows:

1. With the PIR temporarily mounted at its intended location, remove the PIR from its mounting plate and activate the tamper switch to start the walk test mode.
2. Replace the sensor in its mounting plate.
3. Place the control panel in Sensor test mode. Move across the detection pattern until the sensor's LED turns on. STOP your motion.
4. Listen for the appropriate system response. Refer to the specific panel installation manual for details on system response. If the system does not respond as expected, proceed to the "Troubleshooting" section.

Mounting

The sensors must be incline-mounted on a wall surface or incline-mounted in a corner at a mounting height of 7.5 ft. (2.5 m).

To Mount the Sensor

1. Remove the mounting plate by depressing the button on the top of the sensor body. With the opposite hand pull the mounting plate away from the body of the sensor.
2. Punch out the mounting holes that best fit your application. See Figure 3 for wall mount options.
3. See Figure 4 to determine which knockouts to use when mounting the motion sensor. Use the lower-side holes for corner mounting, or the lower-back holes for surface mounting.
4. If wall-tamper functionality is desired, remove the wall-tamper knockout See Figure 4.

Figure 4: PIR Mounting Plate Knockouts

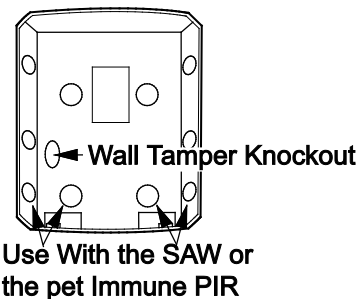

6. Mark the location of the required holes on the mounting surface.

7. Use wall anchors and screws to secure into place. Attach the sensor to the mounting plate.
8. When testing is completed the PIR can be securely attached to its mounting plate by screwing the smallest enclosed screw into the hole at the top of the mounting plate.

Setting the Sensitivity

The PIR has two sensitivity settings (standard and high sensitivity). The sensor is set to standard sensitivity at the factory. This sensitivity is preferred for most applications and provides the best immunity to false alarms.

Note: If the shorting jumper is not used or is placed incorrectly, the sensor defaults to standard sensitivity.

Figure 5: Sensitivity Pin Locations

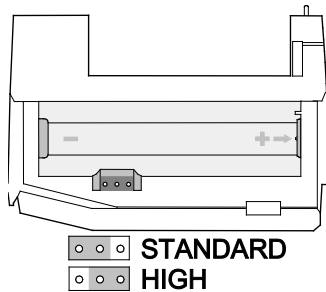

CAUTION: High sensitivity should only be used in environments where the room temperature is very stable.

1. Remove the mounting plate by depressing the button on the top of the sensor body. With the opposite hand pull the mounting plate away from the body of the sensor.
2. Remove the PIR cover by depressing the three tabs
3. Locate the sensitivity pins under the battery on the right side of the PIR when looking at the front of the PIR.
4. To change to high sensitivity move the shorting jumper to the pair of pins that are closer to the top of the PIR. See Figure 5.
5. Walk test the PIR to verify the sensitivity.

The difference between the two settings are indicated in Figures 6 and 7 below.

Figure 6: Standard Sensitivity Setting

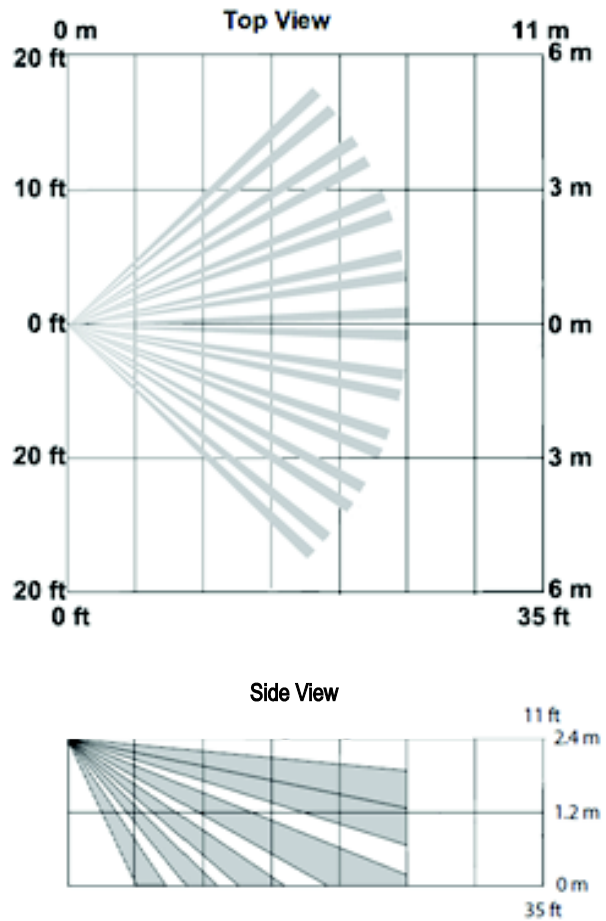
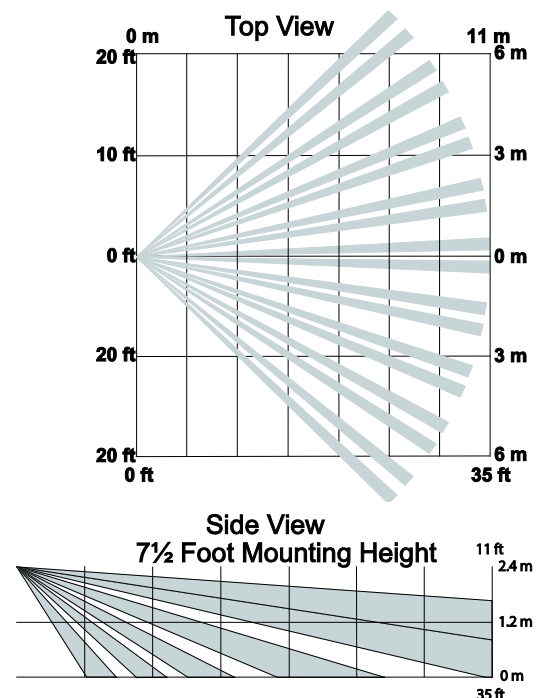

Figure 7: High Sensitivity Setting



Important information Regarding Sensitivity Settings

The sensitivity settings should be set as followed:

Standard Sense:

- Rooms < 25ft
- Pets < 40 pounds

High Sense:

- Rooms < 35ft
- Pets < 20 pounds

Testing

Walk Testing

Walk testing should be done to determine the sensor's actual coverage area. The edge of the coverage pattern is determined by the first flash of the LED. This may change slightly depending upon the sensitivity setting. Walk test the unit from both directions to determine the pattern boundaries.

CAUTION: Excessive use of the walk test mode may reduce battery life. Use only for initial setup and maintenance testing.

1. Remove the sensor body from the mounted mounting plate and then remount the body to activate the 60 second walk test mode.
2. Walk across the coverage pattern to determine the coverage area, indicated by LED activation. Each activation extends the walk test mode for an additional 60 seconds.

After 60 seconds without motion the walk test mode and the LED will no longer activate when motion is detected.

Note: When the walk test mode has ended, an alarm can be transmitted only after 3 minutes have passed since the previous alarm. This 3 minute lockout time reduces unnecessary RF transmissions in high traffic areas thereby extending battery life.

Environment Testing

Turn on all heating or air conditioning sources which would normally be active during the protection period. Stand away from the sensor and outside the coverage pattern and watch for alarms. When testing the Pet Immune PIR also verify the pets allowed in the coverage pattern do not trip the PIR.

Maintenance

At least once a year, the range and coverage should be verified for proper operation. The end user should be instructed to put the sensor in walk test mode and walk through the far end of the coverage pattern to verify proper detection.

Replacing the Batteries

When the system indicates the sensor has low batteries, replace the batteries immediately. The sensors are powered by the batteries shown in Table 2. Use only the batteries indicated in Table 2 for the appropriate sensor. See the steps listed after Table 2 for replacing the batteries.

Table 2: Battery Replacement

60-807-95R	Two AA Alkaline Batteries
60-807-01-95R	One AA Lithium Battery (#60-619).
60-807-02-95R	Two 1.5 AA Lithium Iron Disulfide Batteries (#60-931).

1. Remove the mounting plate by depressing the button on the top of the sensor body. With the opposite hand pull the mounting plate away from the body of the sensor. See Figure 8.
2. Remove the PIR cover by depressing the three tabs. See Figure 8.
3. Remove the old batteries and replace them with new batteries as noted in Table 2 and Figure 8.

Note: Observe polarity when replacing the batteries. For all units install the battery on the right side as shown in Figure 8 with the positive end of the battery facing down (near the tamper switch). For 60-807-95R and 60-807-02-95R units with two batteries, install the second battery on the left side with the positive end of the battery facing up. See Figure 8.

If a battery is installed incorrectly the unit will not function and the red LED will not light up. The sensor may be damaged if a battery is installed incorrectly. For sensors with two batteries, always replace both batteries.

4. Dispose of the batteries as required by local requirements
5. Walk test the PIR to verify proper operation.
Note: When the battery is replaced, wait at least three minutes after installing the battery before activating the walk test mode.

Figure 8: PIR Components, Battery Locations & Tamper Switch

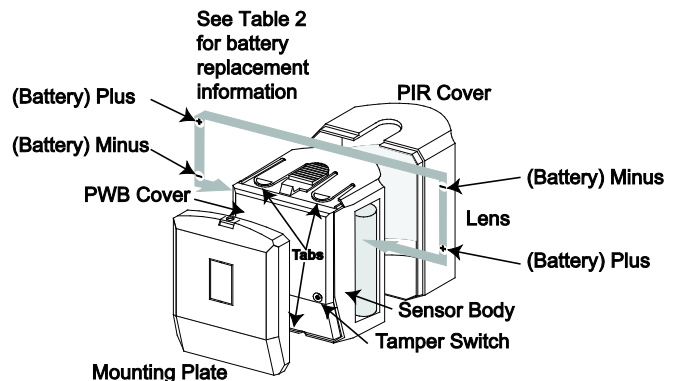

Troubleshooting

Use the following guidelines if the system does not respond correctly when the sensor final testing is conducted.

- Check programming and re-program sensor into panel if necessary.
- Move the sensor to another location and test for correct response.
- Check the mounting height and angle are according to “Mounting” section.

To Relocate a Sensor

1. Test the sensor a few inches from the original position.
2. Increase the distance from the original position and retest until an acceptable location is found.
3. Mount the sensor in the new location.
4. If no location is acceptable, test the sensor as described below:
 - Test a known good sensor at the same location.
 - If the system does not respond, avoid mounting a sensor at that location.
 - If the replacement sensor functions, return the problem sensor for repair or replacement.

Specifications

60-807-95R

RF Frequency	319.5 MHz
Compatibility	Interlogix 319.5 MHz control panels/receivers
Battery Type	Two AA Alkaline Batteries
Typical Battery Life	2 – 4 years at 68° F (20° C)
Operating Temperature Range	32° to 110°F (0° to 43°C) Non-pet applications 60° to 110°F (16° to 43°C) Pet applications
Supervisory Interval	64 Minutes
Relative Humidity	0 – 90% non-condensing
Storage Temperature Range	-30 to 140°F (-34 to 60°C)
Weight	0.3 lbs (0.136 kg)
Dimensions (L x W x H)	2.875 x 2.375 x 1.875 in. (7.303 x 6.033 x 4.763 cm)

60-807-01-95R

RF Frequency	319.5 MHz
Compatibility	Interlogix 319.5 MHz control panels/receivers
Battery Type	One AA Lithium Battery Interlogix part #60-619
Typical Battery Life	4 – 6 years at 68° F (20° C)
Operating Temperature Range	32 to 120°F (0 to 49°C) Non-pet applications 60 to 120°F (16 to 49°C) Pet applications
Supervisory Interval	64 Minutes
Relative Humidity	0 – 90% non-condensing
Storage Temperature Range	-30 to 140°F (-34 to 60°C)
Weight	0.3 lbs (0.136 kg)
Dimensions (L x W x H)	2.875 x 2.375 x 1.875 in. (7.303 x 6.033 x 4.763 cm)

60-807-02-95R

RF Frequency	319.5 MHz
Compatibility	Interlogix 319.5 MHz control panels/receivers
Battery Type	Two 1.5V AA Lithium Iron Disulfide Batteries (Interlogix part # 60-931, six pack of batteries). Note: Use only AA 1.5 Volt Lithium Iron Disulfide batteries (part # 60-931) with this product. Do not substitute any other brand/type of batteries.
Typical Battery Life	2-5 years at 68° F (20° C)
Operating Temperature Range	32 to 120°F (0 to 49°C) Non-pet applications 60 to 120°F (16 to 49°C) Pet applications
Supervisory Interval	64 Minutes
Relative Humidity	0 – 90% non-condensing
Storage Temperature Range	-30 to 140°F (-34 to 60°C)
Weight	0.3 lbs (0.136 kg)
Dimensions (L x W x H)	2.875 x 2.375 x 1.875 in. (7.303 x 6.033 x 4.763 cm)

Regulatory Information

This equipment has been tested and found to comply with the limits for a Class B digital device, pursuant to Part 15 of the FCC Rules. These limits are designed to provide reasonable protection against harmful interference in a residential installation.

This equipment generates, uses and can radiate radio frequency energy and, if not installed and used in accordance with the instructions, may cause harmful interference to radio communications. However, there is no guarantee that interference will not occur in a particular installation.

If this equipment does cause harmful interference to radio or television reception, which can be determined by turning the equipment off and on, the user is encouraged to try to correct the interference by one or more of the following measures:

- Reorient or relocate the receiving antenna.
- Increase the separation between the equipment and receiver.
- Connect the equipment into an outlet on a circuit different from that to which the receiver is connected.
- Consult the dealer or an experienced radio/TV technician for help.

Changes or modifications not expressly approved by UTC Fire and Security could void the user's authority to operate the equipment.

This device complies with Industry Canada licence-exempt RSS standard(s). Operation is subject to the following two conditions: (1) this device may not cause interference, and (2) this device must accept any interference, including interference that may cause undesired operation of the device.

Cet appareil est conforme avec Industrie Canada exempts de licence standard RSS (s). Son fonctionnement est soumis aux deux conditions suivantes: (1) cet appareil ne doit pas provoquer d'interférences et (2) cet appareil doit accepter toute interférence, y compris celles pouvant causer un mauvais fonctionnement de l'appareil.

In accordance with FCC requirements of human exposure to radiofrequency fields, the radiating element shall be installed such that a minimum separation distance of 20 cm is maintained from the general population.

FCC: B4Z-680F-PIR
IC: 1175C-680PIR

This Class B digital apparatus complies with Canadian ICES-3B.

Cet appareil numérique de la classe B est conforme à la norme NMB-3B du Canada.

Contact Information

For general information, see www.interlogix.com. For customer/technical support, see www.interlogix.com/customer-support or call +1 855 286 8889.

© 2014 United Technologies Corporation. Interlogix is part of UTC Building and Industrial Systems, a United Technologies Corporation. All rights reserved. The Product Name and logo are trademarks of United Technologies. Other trade names used in this document may be trademarks or registered trademarks of the manufacturers or vendors of the respective products.

Limitation of Liability

To the maximum extent permitted by applicable law, in no event will Interlogix be liable for any lost profits or business opportunities, loss of use, business interruption, loss of data, or any other indirect, special, incidental, or consequential damages under any theory of liability, whether based in contract, tort, negligence, product liability, or otherwise. Because some jurisdictions do not allow the exclusion or limitation of liability for consequential or incidental damages the preceding limitation may not apply to you. In any event the total liability of Interlogix shall not exceed the purchase price of the product. The foregoing limitation will apply to the maximum extent permitted by applicable law, regardless of whether Interlogix has been advised of the possibility of such damages and regardless of whether any remedy fails of its essential purpose.

Installation in accordance with this manual, applicable codes, and the instructions of the authority having jurisdiction is mandatory.

While every precaution has been taken during the preparation of this manual to ensure the accuracy of its contents, Interlogix assumes no responsibility for errors or omissions.