

# SuperBus®2000 RF Receiver Module

Document Number: 466-1565-01 Rev. A  
June 2000

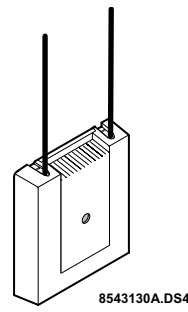

## Installation Instructions

### Product Summary

The SuperBus 2000 RF Receiver Module is a UL listed device that adds or expands panel wireless zone capacity. See the specific panel *Installation Instructions* for complete UL requirements for the system you are installing.

The receiver is compatible with all ITI 319.5 MHz (crystal and SAW) Learn Mode™ wireless sensors and touchpads, and can be mounted inside the panel cabinet or located up to 2,800 feet away from the panel (see Table 2). It receives information from wireless sensors and touchpads then sends the data to the panel via the SuperBus 2000 digital data bus. Power for the module is provided by the panel.

Receivers are available in 16-zone (-16Z), 32-zone (-32Z), or panel maximum (-MAX) capacities.

#### SuperBus 2000 vs. SuperBus

SuperBus 2000 panels have the ability to auto-address module unit numbers. When the panel is powered up, the panel automatically reads the unique SuperBus 2000 device ID number and assigns a unit number to the module. This eliminates manually setting DIP switches and the chance of identical unit number conflicts.

SuperBus panels communicate with SuperBus 2000 modules but require the module unit number to first be set manually using DIP switches.

#### The SuperBus 2000 RF Receiver Module features:

- Spatial diversity, which minimizes wireless signal nulls or dead spots.
- Compatibility with all ITI 319.5 MHz (crystal or SAW) Learn Mode™ wireless sensors, touchpads, and sirens.
- Backward compatibility with SuperBus panels.
- 1,500 feet nominal, open air receiving range.

Figure 1 shows the receiver module components and Table 1 describes them.

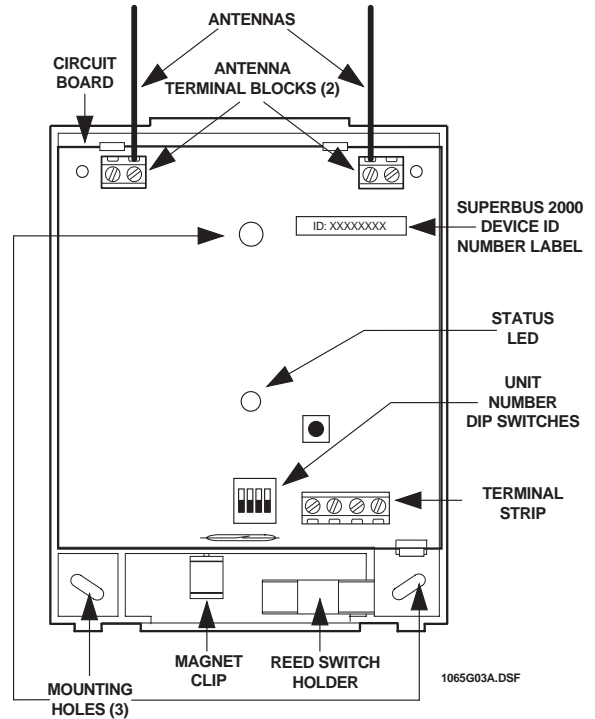

Figure 1. RF Receiver Module Components

Table 1. Component Descriptions

Component	Function
Antennas	Provide communication with wireless devices.
SuperBus 2000 Device ID Number Label	Identifies unique module SuperBus 2000 device ID number (SuperBus 2000 panels).
Receiver Status LED	On continuously when the receiver is powered. Flashes when an RF signal is received.
Unit Number DIP Switches	Used for manually setting unit numbers (SuperBus panels).
Terminal Strip	Used for power and bus connections to panel.

## Installation Guidelines

Observe the following guidelines when installing the receiver module:

- ❑ Concord™ systems can accommodate a maximum of 76 wireless sensors/zones.
- ❑ In Concord systems, up to 16 SuperBus 2000 devices can be connected to the panel (SuperBus 2000 Touchpads, Receivers, HIMs, HOMs, ESMs, etc.).
- ❑ Each bus device must have a different unit number.
- ❑ Leave 10-inches above the module for the antennas.
- ❑ If mounting the module inside the panel cabinet, use a support standoff included with the Concord panel.

If mounting the module away from the panel, use the wire length guidelines in Table 2.

**Table 2. Maximum Module Wire Lengths**

Wire Gauge (Unshielded or Shielded)	Max. Wire Length Between Module and Concord Panel
18	2,800 feet
22	1,100 feet

- ❑ Avoid areas that are likely to expose the module to moisture.
- ❑ Avoid areas with excessive metal or electrical wiring, including furnace and utility rooms.

If unavoidable, mount on or near metal with the antennas extending above the metallic surfaces, as shown in Figure 2.

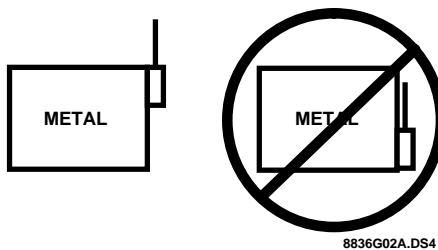

**Figure 2. Mounting on or Near Metal**

## Tools and Supplies

- ❑ Screwdrivers
- ❑ Drill with bits
- ❑ Mounting screws and anchors (included)
- ❑ 2 antennas (included)
- ❑ 4-conductor, 22-gauge or larger, stranded wire
- ❑ Support standoff (included with Concord cabinet)
- ❑ ¼-inch press-fit reed switch and magnet (not included)
- ❑ Small hammer

## Installation

The module can be mounted inside the panel cabinet or on any interior wall (protected from the elements).

 **CAUTION**  
To prevent damaging the panel or module, remove the panel AC power transformer and disconnect the backup battery before installation.

 **CAUTION**  
You must be free of static electricity before handling circuit boards. Wear a grounding strap or touch a bare metal surface to discharge static electricity.

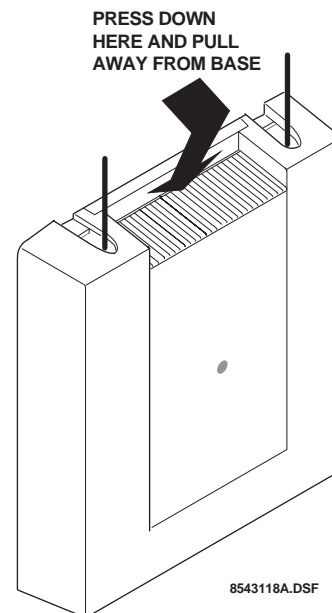

**Figure 3. Removing the Cover**

### To mount the module on a wall:

1. Remove the panel AC power transformer and disconnect the backup battery.
2. Remove the module cover and set it aside (Figure 3).
3. Hold the base against the mounting surface and mark the three mounting holes (Figure 1). Remember to leave at least 10 inches above the base for the antennas.
4. Drill holes and insert the appropriate anchors.
5. Secure the back-plate to the wall with included pan-head screws.

### To mount the module in a Concord panel cabinet:

1. Remove the panel AC power transformer and disconnect the backup battery.
2. Remove and discard the module cover (Figure 3).

3. Insert a support standoff shown in Figure 4 (supplied with panel) into the panel circuit board location shown in Figure 5.

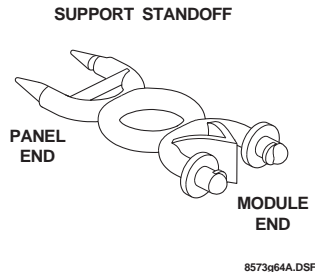

Figure 4. Support Standoff

4. Slide the module back-plate into the two top mounting clips located on the top-right side of the cabinet and onto the right-side support on the cabinet (see Figure 5).

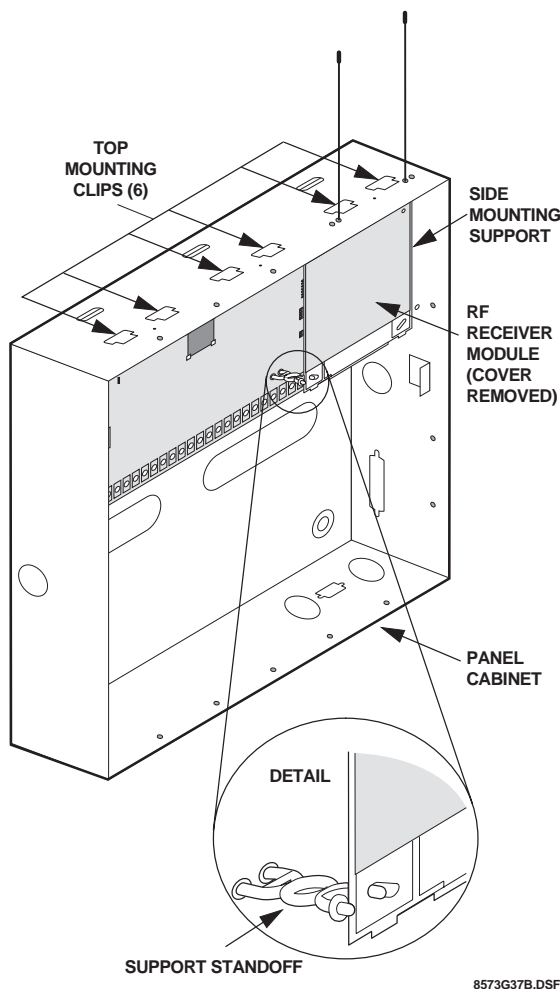

Figure 5. Mounting the module in a Concord Cabinet

5. Push the lower-left corner of the module onto the support standoff (see detail in Figure 5).

## Connecting the Antennas to the Module

1. Loosen the **inside** terminals of the left and right antenna terminal blocks (see Figure 1).
2. Insert an antenna into each **inside** terminal. (Insert antennas through cabinet top holes when module is mounted inside panel cabinet.)
3. Tighten the antenna terminal screws.

## Concord Panel Wiring

This section describes how to wire the receiver module to Concord panels.

### To wire the receiver module to Concord panels:

1. Disconnect the panel power transformer and backup battery.
2. Wire the module to the panel power and bus terminals as shown in Figure 6.

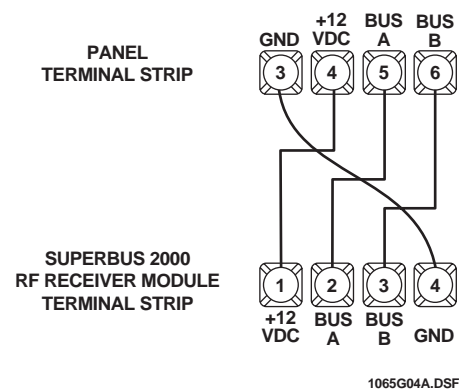

Figure 6. Wiring the Receiver Module to Concord Hard-wire and Wireless Panels

## Installing an Optional Cover Tamper Switch

If you are mounting the module in its own plastic and not mounting it inside a cabinet, you may want to add cover tamper detection.

To do this, install a UL listed 1/4-inch press-fit reed switch on the module back-plate and wire the switch to any unused panel, HIM, or SnapCard™ zone input terminals. Once programmed, if someone opens the module cover, the tamper switch opens and causes an alarm.

The reed switch holder and magnet clip are located at the bottom of the back-plate (see Figure 1 for details).

### To install the tamper reed switch (Figure 7):

1. Slide the reed switch into the reed switch holder located on the module back-plate as shown in Figure 7.

- Insert the magnet into the nibs on the module cover. Remove the magnet clip from the module back-plate and press the magnet clip down over the magnet until it clicks into place (Figure 7).
- Connect the normally closed reed switch (in series with a 2.0K ohm EOL resistor) to the desired panel, HIM, or SnapCard zone input terminals. The resistor should be located at the reed switch inside the module housing.

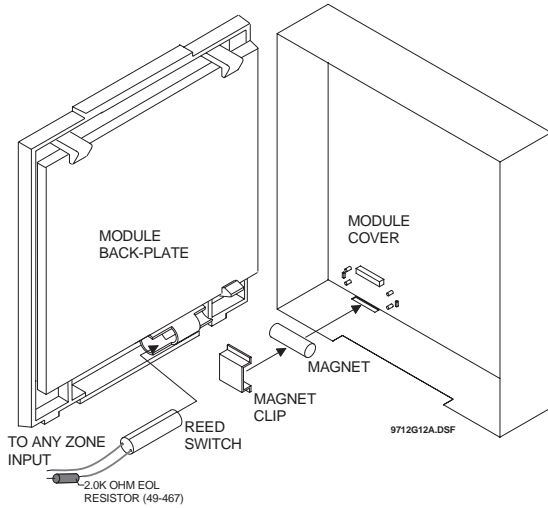

Figure 7. Installing the Optional Reed Switch

## Setting the Unit Number

Each bus module connected to the panel must have a different unit number set for correct communication.

### Setting the Unit Number on Concord Panels with Software Versions 1.0–1.6

The module can be set to any unit number 0–15, using the module DIP switches.

**Note**

Do not set the SuperBus 2000 RF Receiver unit number to 15 if it is installed in a Concord RF system, since the built-in receiver is factory set to unit number 15 and cannot be changed.

Locate the DIP switches on the module and set them to the desired unit number (0–15) *before* applying power (see Figure 8).

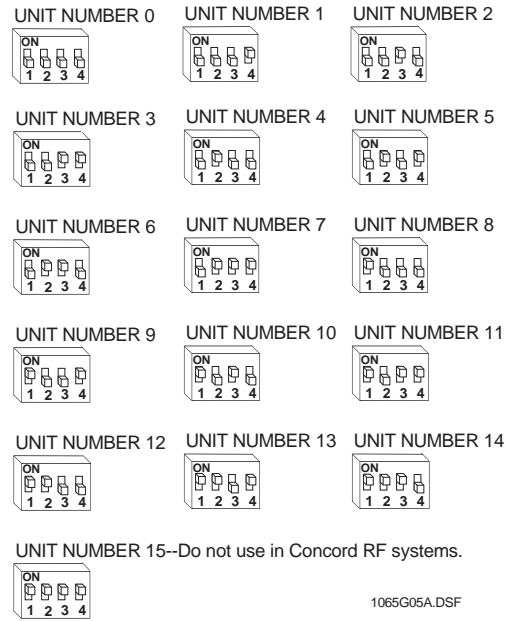

Figure 8. Unit Number DIP Switch Settings

### Setting the Unit Number on Concord Panels with Software Version 2.0 or Later

The unit number will be automatically set when powering up the system. No action is required by the installer.

## Power Up and Bus Communication

Use the following procedures for powering up the system and verifying bus communication.

**Note**

In order to enter panel program mode to verify unit numbers, an alphanumeric touchpad must be connected to all Concord panels.

#### To power up the panel and receiver module:

- Verify that all wiring at the panel, touchpad, and receiver is correct.
- Connect the panel backup battery and plug in the panel AC power transformer.
- Verify that the receiver module status LED is on.
- If desired, enter panel program mode to verify unit number exists (see panel *Installation Instructions* for more information).

**Note**

If the receiver module LED is not on, unplug the panel AC power transformer, disconnect the backup battery, and see Table 3 "Troubleshooting".

## Changing the Receiver Module Unit Number (software versions 1.0–1.6)

### Note

Whenever the receiver module unit number is changed, you must remove the panel AC power transformer and backup battery, then reconnect them for the panel and module to communicate successfully.

Use the following guidelines when changing unit number assignments to avoid communication conflicts between bus devices and the panel:

- ❑ Whenever possible, assign alphanumeric touchpad unit numbers before all other panel programming.
- ❑ All unit number DIP switches must be set before applying power and entering program mode.

### To change the receiver module unit number:

1. Remove panel AC power transformer and backup battery.
2. Change the DIP switch setting on the module (see Figure 8). Remember, the setting must be different from all other bus devices.
3. Connect the panel backup battery and plug in the AC power transformer. The panel automatically scans all bus devices and learns any new settings.
4. The system may still indicate a bus failure if the panel learned a unit number that is no longer assigned to any bus device. To delete the unused unit number, please refer to the specific panel *Installation Instructions*.
5. Exit from program mode. The touchpad and all other bus devices should operate correctly and any bus failures should be cleared.

### Replace Module Cover/Close Cabinet

- ❑ If you mounted the receiver module on a wall, replace the cover.
- ❑ If you mounted the receiver module in a cabinet, close the cabinet door.

## Programming

Refer to the panel *Installation Instructions* for learning wireless devices into panel memory.

## Testing

Test the receiver module at the desired location to evaluate performance in the particular environment.

Verify that the receiver module LED flashes when wireless devices are activated.

For complete testing procedures, refer to the panel *Installation Instructions*.

## Troubleshooting

Table 3 describes what to do if the module does not work correctly.

**Table 3. Troubleshooting**

Problem	Action/Solution
The receiver module status LED stays off.	<ol style="list-style-type: none"> <li>1. Check for incorrect wiring connections.</li> <li>2. Make sure the panel AC power transformer is plugged in and the backup battery is connected.</li> <li>3. If the LED still remains off, replace the module.</li> </ol>
The receiver module status LED stays lit but doesn't blink when wireless devices are tripped (limited or no wireless operation).	<ol style="list-style-type: none"> <li>1. Verify that the panel recognizes the module by entering program mode (see specific panel <i>Installation Instructions</i>).</li> <li>2. Check for incorrect wiring connections.</li> <li>3. Check receiver antenna connections.</li> <li>4. Check for receiver antenna proximity to metal obstructions such as ducting or AC wiring.</li> <li>5. If the LED still doesn't flash, replace the module.</li> </ol>
The receiver module status LED stays lit and blinks when wireless devices are tripped, but system doesn't respond.	<p><i>Concord Panels 1.0–1.6</i></p> <ol style="list-style-type: none"> <li>1. Check that no bus devices are set to the same unit number.</li> <li>2. Change the module unit number and re-initialize the panel/module by disconnecting and reconnecting panel power.</li> </ol> <p><i>All Concord Panels</i></p> <ol style="list-style-type: none"> <li>1. Make sure that the wireless zone capabilities of the module and panel have not been exceeded. (Removing one of two receiver modules connected to a panel after wireless devices are learned can cause this problem.)</li> <li>2. If the system still doesn't respond, replace the module.</li> </ol>

## Specifications

- Compatibility: ITI Concord panels. ITI 319.5 MHz (crystal and SAW) Learn Mode wireless sensors and touchpads
- Wireless Zones: 60-764-01-95R-16Z  
Up to 16 wireless zones  
60-764-01-95R-32Z  
Up to 32 wireless zones  
60-764-01-95R-MAX  
Maximum panel capacity
- Power Required: 12 VDC nominal  
30 mA maximum draw  
(from panel)
- Storage Temperature: -30° to 140°F (-34° to 60°C)
- Operating Temperature: 32° to 140°F (0° to 60°C)
- Maximum Humidity: 90% relative humidity,  
noncondensing
- Wireless Signal Range: 1,500 feet nominal, 2,000 feet  
typical open air (may vary with  
application)
- UL Listings (see note): UL 985 Household Fire Warning  
System Units (applied for)
- UL 1023 Household Burglar-Alarm  
System Units (applied for)
- UL 1610 Central Station Burglar-  
Alarm Units (applied for)
- Note  
See specific panel *Installation Instructions* for  
complete UL installation requirements for the system  
you are installing.
- Dimensions: 4.125" x 5.25" x 1.0" (L x W x H),  
excluding antennas

## Notices

This device complies with FCC Rules Part 15. Operation is subject to the following two conditions:

This device may not cause harmful interference.

This device must accept any interference that may be received, including interference that may cause undesired operation.

Changes or modifications not expressly approved by Interactive Technologies, Inc. can void the user's authority to operate the equipment.



**INTERACTIVE TECHNOLOGIES, INC.**

2266 SECOND STREET NORTH  
NORTH SAINT PAUL, MN 55109

T: 651-777-2690

F: 651-779-4890

W I R E L E S S

Security

Automation

Access Control

© 2000 interlogix™, inc. interlogix is a trademark of interlogix, inc.  
ITI is a registered trademark of interlogix, inc. SuperBus is a registered  
trademark of Interactive Technologies, Inc. Concord, Learn Mode, and  
SnapCard are trademarks of Interactive Technologies, Inc.