

# AP750W Wireless PIR Motion Sensor Installation Instructions



## Contents

Product Summary .....	1
Installation Guidelines .....	1
Tools and Supplies Needed .....	2
Mounting the Sensor.....	3
Setting the Sensor Coverage Area and Sensitivity .....	3
Walk Testing .....	4
Environment Testing.....	4
Installing Masks .....	4
Self-Adhesive Masks .....	4
Plastic Masks.....	4
Programming .....	5
Final Testing .....	5
Maintenance .....	5
Replacing Batteries.....	5
Lithium Battery Disposal .....	6
Troubleshooting .....	6
Specifications.....	6
Regulatory information .....	6
Contact Information .....	7

## Product Summary

The AP750W Wireless PIR (passive-infrared) Motion Sensor detects movement by sensing the infrared energy emitted from a body as it moves across its field of view. When this motion is detected, the sensor transmits an alarm signal.

Install motion sensors to protect areas where door/window sensors are impractical or not needed. For example, use a motion sensor to protect large areas or open floor plans. Motion sensors can also provide backup protection in areas where door/window sensors exist.

This wireless motion sensor includes the following features:

- Field-selectable coverage area; 33 or 50 feet
- Field-selectable sensitivity modes; 2-pulse or 4-pulse
- 135-second transmitter lockout time after an alarm that helps extend battery life
- Cover-activated tamper
- Supervisory signal transmitted every 64 minutes to the control panel
- Sensor low battery reports (trouble) to the control panel

Included with the sensor is a thin cardboard under-crawl mask and snap-in plastic masks (installed at the factory). Self-adhesive masking strips are also included.

## Installation Guidelines

If possible, locate sensors within 100 feet of the panel. While a transmitter may have an open-air range of 500 feet or more, the installation site can have a significant effect on transmitter range. Changing the sensor location may help overcome adverse wireless conditions.

- Mount the sensor permanently on a flat wall or in a corner. Do not set it on a shelf.
- For installations without pets, the required mounting height is 7½ feet.
- Mount the motion sensor on an insulated, outside wall facing in.
- Mount the motion sensor on a rigid surface which is free from vibrations.
- Position the sensor so it faces a solid reference point, like a wall.
- Do not aim the sensor at windows, fireplaces, air conditioners, heaters/heating vents, or place it in direct sunlight.
- Position the sensor to protect an area where intruders are most likely to walk across the detection pattern (see Figure 1: Overhead View Walking Across Detection Pattern).

**Figure 1: Overhead View Walking Across Detection Pattern**

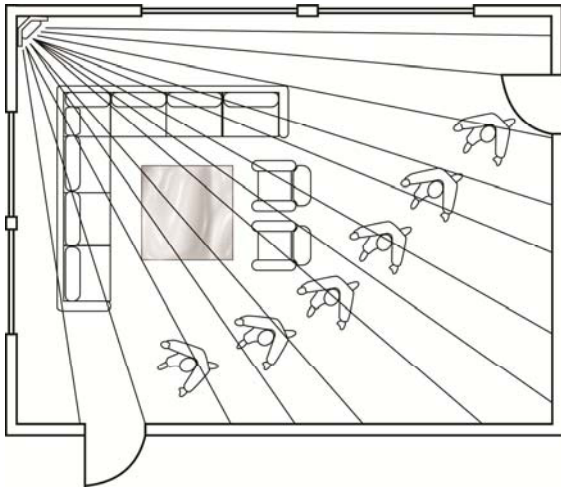

- Do not mount the sensor near duct work or other large metallic surfaces which may affect the RF signals (see "Final Testing" on page 4). Actual acceptable transmitter range should be verified for each installation.
- Windows should be closed in any area which has an armed motion sensor.
- The cardboard under-crawl mask installed at the factory (see Figure 2) blocks coverage within 5 feet of the sensor.

**Figure 2: Cardboard Under-crawl Mask Location**

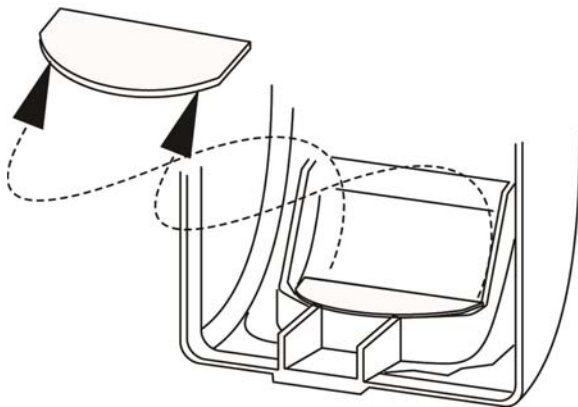

**Note:** The cardboard under-crawl mask should remain installed when sensor jumper J1 is set to the BI position. See the section "Setting the Sensor Coverage Area and Sensitivity" for complete information on sensor jumper settings.

- For installations where pets are present, mount the sensor upside down about 3.5 feet above the floor (see Figure 3). Leave the factory-installed under-crawl mask in place to block any detection pattern directed at the ceiling.

**Figure 3: Pet Alley Application**

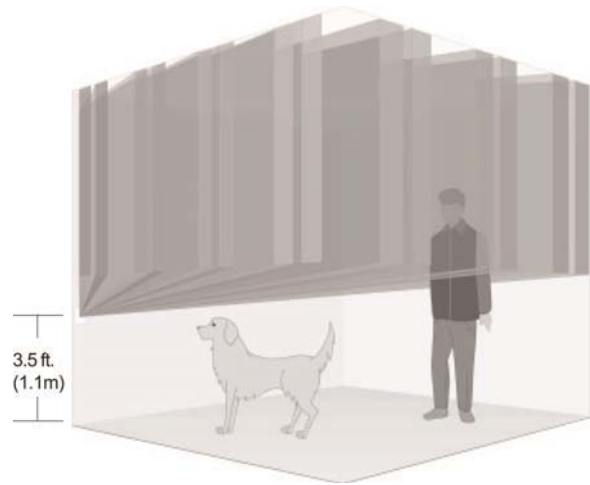

### Tools and Supplies Needed

- Phillips screwdriver
- Anchors and screws for mounting (included)
- Masks (included)

# Mounting the Sensor

This section describes how to mount the sensor on a flat wall or in a corner.

**Note:** Remove the factory-installed plastic masks before mounting. Re-install as desired after walk testing.

**Caution:** You must be free of all static electricity before handling sensor circuit boards. Touch a grounded, bare metal surface before touching circuit boards or wear a grounding strap.



1. Remove the small cover (see Figure 4).

**Figure 4: Removing the Small Cover**

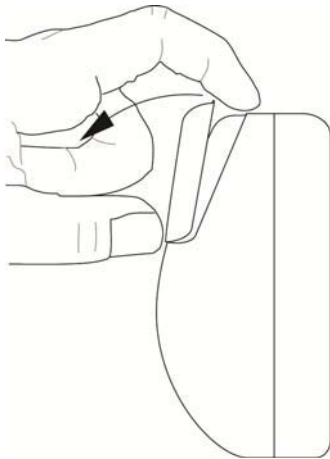

2. Open the sensor housing by pressing down on the top rear and pulling the front cover at the top (see Figure 5). Set the front cover aside.

**Figure 5: Opening the Sensor Housing**

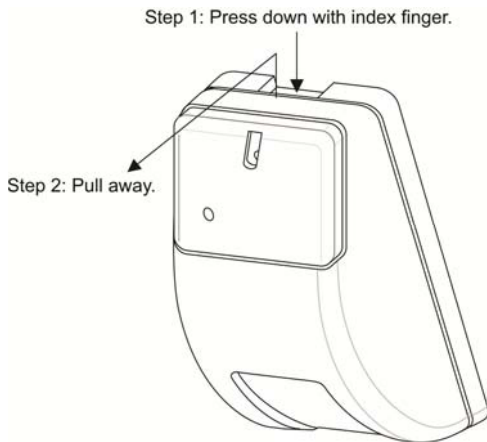

3. Mount the sensor on a flat wall or in a corner, using the appropriate mounting holes (see Figure 6). Use wall anchors and screws to secure the sensor.

**Note:** Avoid touching the mirror. Fingerprints may affect detection coverage.

**Figure 6: Mounting Hole Locations**

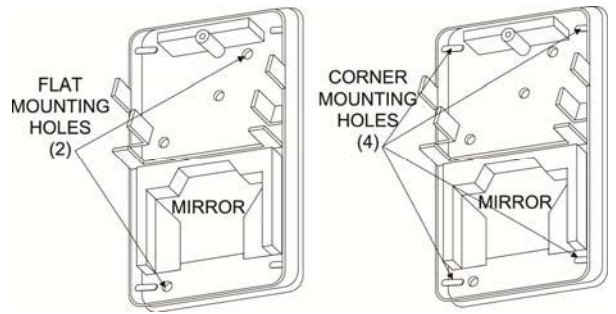

## Setting the Sensor Coverage Area and Sensitivity

Jumper J1 determines the sensitivity mode of the sensor, either standard or bi-curtain. Jumper J2 determines the coverage area of the sensor, either 33 or 50 feet. See Figure 7 for jumper positions.

Use the standard (STD) setting for wide-angle coverage and single curtain pattern. Use the bi-curtain (BI) setting for added stability to help reduce false alarms. This mode requires intruders to be detected by two curtains of coverage.

**Note:** Do not use the bi-curtain mode for detection in areas within 5 feet of the sensor. When selecting bi-curtain mode, always leave the cardboard under-crawl mask installed.

**Caution:** You must be free of all static electricity before handling sensor circuit boards. Touch a grounded, bare metal surface before touching circuit boards or wear a grounding strap.



**Figure 7: Sensitivity Mode and Coverage Area Jumper Settings**

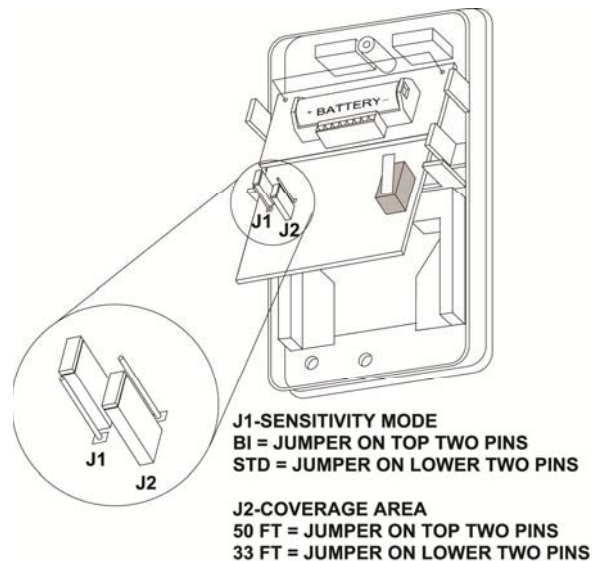

## Walk Testing

Walk testing should be done to determine the actual coverage area of the sensor. The edge of the coverage pattern is determined by the first LED flash. This may change slightly depending on the sensitivity setting. Walk test the unit from both directions to determine the pattern boundaries.

1. Remove the sensor cover to activate the tamper switch and then reattach it to activate the 2-minute walk test mode.
2. Walk across the coverage pattern to determine the coverage area, indicated by LED activation.

After 2 minutes, the walk test mode and the LED will no longer activate when motion is detected.

**Note:** Excessive use of the walk test mode may reduce battery life. Use only for initial setup and maintenance testing.

**Note:** In normal operation mode, the sensor only transmits an alarm signal 135 seconds after the previous alarm. This reduces unnecessary RF transmissions in high traffic areas, thereby extending battery life.

## Environment Testing

Activate the walk test mode and then turn on all heating or air conditioning sources which would normally be active during the protection period. Stand away from the sensor and outside the coverage pattern and watch for alarms.

## Installing Masks

After determining the full coverage area and performing the environment test, you may need or want to mask (block) certain parts of the coverage.

### Self-Adhesive Masks

Block the appropriate mirror sections with these masks. Figure 8 shows an example of where to apply the masks and the resulting coverage area.

**Caution:** To avoid damaging the mirror, do not remove masks using a sharp tool. If necessary, remove masks by carefully peeling them off with your fingers.

Figure 8: Installing Self-Adhesive Masks

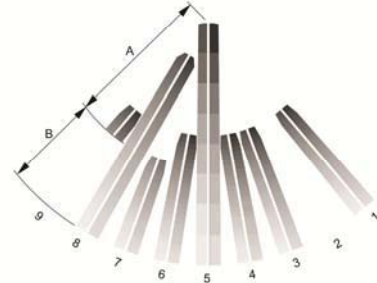
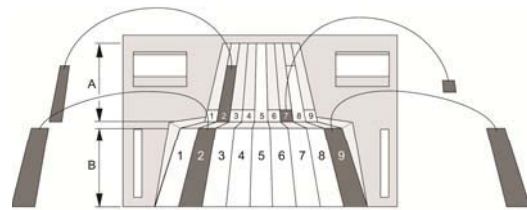

### Plastic Masks

Install these masks for half coverage or narrow coverage applications (see Figure 9).

Figure 9: Installing Plastic Masks

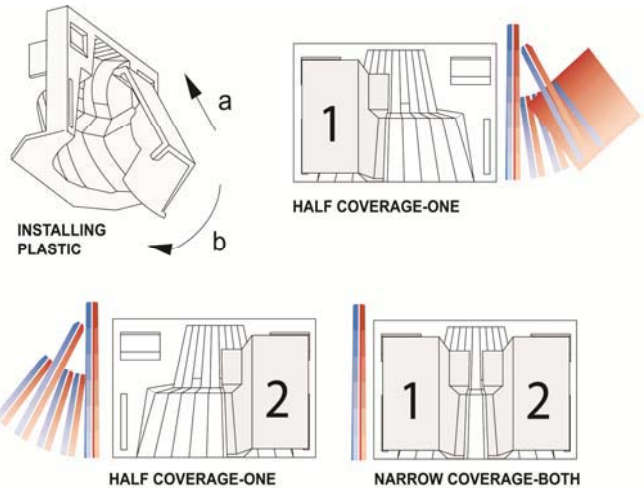

**Note:** After installing masks, always conduct a walk test and environment test to verify the coverage area is correct for the application.

## Programming

The following describes the basic steps for adding (learning) the sensor into panel memory. Refer to the specific panel installation instructions for complete programming information.

1. Put the panel into program mode.
2. Advance to the learn sensors menu.
3. Enter the appropriate sensor group and desired sensor number.
4. When the panel prompts you to trip the sensor, activate the sensor tamper switch by removing the sensor cover.
5. Reattach the sensor cover.
6. Exit from program mode.

## Final Testing

Final testing should be done to verify radio signal integrity and confirm control panel programming and response. The actual transmitter range can be determined by performing a sensor test as described below. Refer to the specific panel installation instructions for complete sensor testing information.

1. After the sensor has been mounted, remove the sensor cover to trip the tamper switch and activate the walk test mode.
2. Replace the sensor cover.
3. Place the control panel in test mode.
4. Move across the detection pattern until the sensor LED turns on and then STOP your motion.
5. Listen for the appropriate system response. If the system does not respond, proceed to the "Troubleshooting" section.

## Maintenance

At least once a year, the sensor should be tested to verify correct operation. The end user should be instructed to put the sensor in walk test mode and walk through the far end of the coverage pattern to verify proper detection.

## Replacing Batteries

When battery replacement is necessary, observe proper polarity (positive +, negative -) when installing the new batteries, or the sensor may be damaged.

Use only exact replacement 3-volt lithium batteries (CR123A).

**Caution:** You must be free of all static electricity before handling sensor circuit boards. Touch a grounded, bare metal surface before touching circuit boards or wear a grounding strap.



1. Remove the sensors cover (see Figures 4 and 5) and set it aside.
2. Remove the transmitter (upper) circuit board battery (see Figure 10).

**Figure 10: Removing the Transmitter Battery**

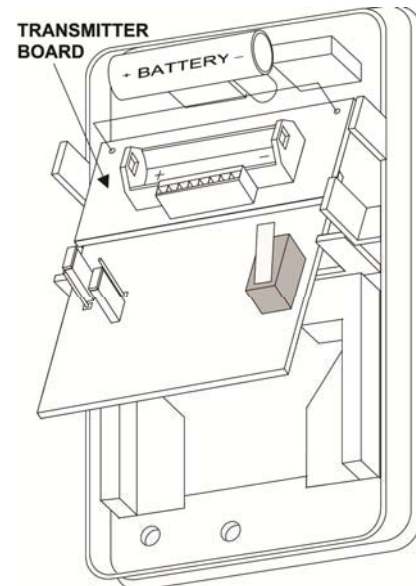

3. Remove the transmitter circuit board and place it inside the cover (see Figure 11).

**Figure 11: Removing the Transmitter Circuit Board**

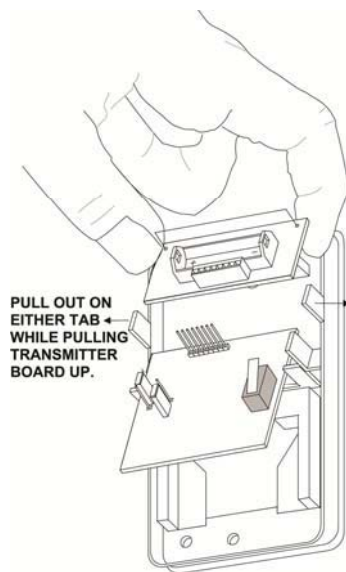

- Carefully remove the PIR (lower) circuit board by pressing outward on either side tab, then pull up on the circuit board (see Figure 12).

**Note:** Avoid touching the mirror. Fingerprints may affect detection coverage.

**Figure 12: Removing the PIR Circuit Board**

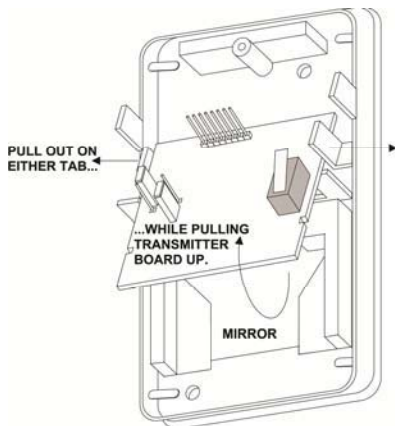

- Remove the PIR circuit board battery (located on opposite side of components) and install a new one, observing polarity (marked on the circuit board).
- Re-install the PIR circuit board into the sensor plastic.
- Re-install the transmitter circuit board onto the PIR circuit board.
- Install a new battery in the transmitter circuit board, observing polarity (marked in battery bucket).

After replacing batteries, wait at least 3 minutes before activating the walk test mode.

## Lithium Battery Disposal

Lithium batteries that are no longer usable are considered hazardous waste. Be sure to properly dispose of the old batteries. Contact your local city government for hazardous waste disposal laws.

## Troubleshooting

Use the following guidelines if the system does not respond correctly when the sensor is activated.

- Check programming and re-program sensor into panel if necessary.
- Move the sensor to another location and test for correct response.
- Test a known good sensor at the same location.
- If the system does not respond, avoid mounting a sensor at that location.
- If the replacement sensor functions, return the problem sensor for repair or replacement.

## Specifications

Compatibility	All ITI 319.5 MHz. Learn Mode Panels
Power source	Two 3-volt lithium (CR123A) batteries
Typical battery life	2-4 years at 68°F (not verified by U.L.)
Operating temperature range	10° to 110°F (-12° to 43°C)
Storage temperature	-40° to 140°F (-40° to 60°C)
Operating relative humidity	5% to 95% non-condensing
Storage relative humidity	95% maximum non-condensing (up to 6 months)
Dimensions (L x W x D)	4.75" (120.65 mm) x 2.6" (66.04 mm) x 2.0" (50.8 mm)

## Regulatory information

---

**Manufacturer** UTC Fire & Security Americas Corporation, Inc. 1275 Red Fox Rd., Arden Hills, MN 55112-6943, USA

---

**FCC compliance** This device complies with part 15 of the FCC Rules. Operation is subject to the following two conditions: (1) This device may not cause harmful interference, and (2) this device must accept any interference received, including interference that may cause undesired operation.

This device complies with Industry Canada license-exempt RSS standard(s). Operation is subject to the following two conditions: (1) this device may not cause interference, and (2) this device must accept any interference, including interference that may cause undesired operation of the device.

Cet appareil est conforme aux normes RSS exempts de licence d'Industrie Canada. Son fonctionnement est soumis aux deux conditions suivantes: (1) cet appareil ne doit pas causer d'interférences et (2) cet appareil doit accepter toute interférence, y compris les interférences pouvant entraîner un fonctionnement non souhaité.

This Class B digital apparatus complies with Canadian ICES-003.

Cet appareil numérique de la classe B est conforme à la norme NMB-003 du Canada.

Changes or modifications not expressly approved by Interactive Technologies, Inc. can void the users' authority to operate the equipment.

**FCC ID:** B4Z-779A-PIR

**IC:** 1175C-779APIR

U.S. Patent Nos: 4,855,713, 4,864,636, 5,761,206, 5,805,063, 5,872,512, and 5,942,981

---

---

## Disclaimer

Information in this document is subject to change without notice. No part of this document may be reproduced or transmitted in any form or by any means, electronic or mechanical, for any purpose, without the express written permission of UTC Fire & Security Americas Corporation, Inc.

---

## Contact Information

For contact information, see [www.utcfireandsecurity.com](http://www.utcfireandsecurity.com) or [www.interlogix.com](http://www.interlogix.com)

For technical support, toll-free: 888.437.3287 / 855.286.8889  
in the US including Alaska, Hawaii, Puerto Rico, and  
Canada.  
Outside toll-free area, contact your dealer.

© 2019 UTC Fire & Security Americas Corporation, Inc.

Interlogix is part of UTC Climate Controls & Security, a unit  
of United Technologies Corporation.  
All rights reserved.

February 11, 2019