

# Allegro

Document Number: 466-1821 Rev. A PRELIMINARY  
February 2002

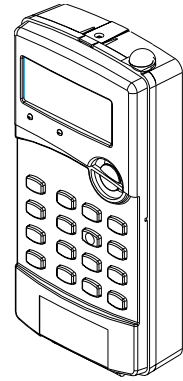

## Contents

- About This Manual ..... 1
- Special Installation Requirements ..... 1
  - UL Listed Systems ..... 1
    - Basic System ..... 1
    - Household Burglary Alarm System Unit (UL 1023) ..... 1
    - Household Fire Warning System (UL 985) ..... 1
    - Digital Alarm Communicator System (UL 1635) . 1
    - Central Station Reporting ..... 1
  - UL-Canada Listed Systems ..... 1
  - California State Fire Marshall Listed Systems ..... 1
- Planning the Installation ..... 1
  - Standard System ..... 1
    - Panel ..... 1
    - DTIM ..... 1
  - Additional System Components ..... 2
- Installing the System ..... 2
  - Determine the Panel Location ..... 2
  - Mounting the Panel ..... 2
  - Connecting Detection Devices to Panel Zone Inputs . 3
    - Connecting Intrusion Detection Devices ..... 3
  - Connecting the AC Power Transformer ..... 3
  - Connecting the Backup Battery Pack ..... 3
  - Powering Up the Panel ..... 4
- Programming the Panel ..... 4
  - Panel Keypad Button Programming Functions ..... 4
  - Moving Through Program Mode Tiers and Menus ..... 4
  - Installer Programing Menu Items ..... 4
    - Entering Installer Programming Mode ..... 4
    - Clearing Memory ..... 5
    - Learning the DTIM into the Panel ..... 5
    - Account Menu ..... 5
      - Account ..... 5
    - Phones Menu ..... 5
      - Number 1 and 2 ..... 5
      - FMT - CID ..... 6
      - High Lvl ..... 6
      - Low Lvl ..... 6
      - Openings ..... 6
      - Closings ..... 6
      - Backup ..... 6
      - Dial Dly ..... 6
      - Pre-Dial String ..... 7

## Installation Instructions

- DTMF Dial ..... 7
- Devices ..... 7
  - Add ..... 7
  - Delete ..... 7
  - Review ..... 8
  - Text ..... 8
- Downloader ..... 9
  - Number ..... 9
  - DL Code ..... 9
- Codes ..... 9
  - Install Code ..... 9
  - Dealer Code ..... 9
  - Duress Code ..... 9
  - Apartment Manager ..... 9
- Timers ..... 10
  - Entry Dly ..... 10
  - Exit Dly ..... 10
  - Phone Test Frequency ..... 10
  - Next Phone Test ..... 10
  - Sleepy Time ..... 10
  - Sleep Hour ..... 10
- Options ..... 10
  - KTP Arm ..... 10
  - Police Panic ..... 10
  - Emergency Panic ..... 11
  - Fire Panic ..... 11
  - Rcvr Trouble ..... 11
  - Panel Tamper ..... 11
  - Exit Ext ..... 11
  - Swinger Shutdown ..... 11
  - Quick Arm ..... 11
  - Quick Exit ..... 12
  - Auto Stay Arm ..... 12
  - Supv Time ..... 12
  - Alarm Verify ..... 12
  - Demo Kit ..... 13
  - Zones ..... 13
- Reports ..... 13
  - AC Fail ..... 13
  - Low CPU Battery ..... 13
  - Phone Test ..... 13
  - Auto Phone Test ..... 14
- Siren ..... 14
  - Siren Time Out ..... 14
  - Trouble Beeps ..... 14
  - Alarm Volume ..... 14
- Exit - DL ..... 14
- User Programing Menu Items ..... 14
  - Entering User Programming Mode ..... 14

## Preliminary 2/5/02

Codes .....	14	Testing Sensors/Zones .....	17
Apartment Manager .....	14	If a Wireless Sensor Does Not Test .....	17
Primary .....	15	Testing Phone Communication .....	17
User 2, 3, 4 .....	15	Testing Central Station Communication .....	17
Time .....	15	Appendix A: Troubleshooting .....	18
Phone Test .....	15	Appendix B: Reference Tables .....	22
Sensor Test .....	15	Appendix C: Installation Menus.....	28
Volume .....	16	Specifications.....	29
Exiting User Programming Mode .....	16		
Downloader Programming .....	16		
ToolBox Downloader Programming .....	16		
Testing the System .....	16		
Basic System Commands .....	16		

## FCC Notices

### FCC Part 15 Information to the User

Changes or modifications not expressly approved by Interlogix Inc. can void the user's authority to operate the equipment.

### FCC Part 15 Class B

This equipment has been tested and found to comply with the limits for a Class B digital device, pursuant to part 15 of the FCC Rules. These limits are designed to provide reasonable protection against interference in a residential installation.

This equipment generates, uses, and can radiate radio frequency energy and, if not installed and used in accordance with the instructions, may cause harmful interference to radio communications. However, there is no guarantee that interference will not occur in a particular installation.

If this equipment does cause harmful interference to radio or television reception, which can be determined by turning the equipment off and on, the user is encouraged to try to correct the interference by one or more of the following measures:

- Reorient or relocate the receiving antenna.
- Increase the separation between the equipment and receiver.
- Connect the affected equipment and the panel receiver to separate outlets, on different branch circuits.
- Consult the dealer or an experienced radio/TV technician for help.

FCC ID: B42-785B-ALGRO



2266 Second Street North | North Saint Paul Mn | 55109 | 800-777-2624 | [www.interlogixinc.com](http://www.interlogixinc.com)  
© 2001 Interlogix,™ Inc. Interlogix is a trademark of Interlogix, Inc. ITI is a registered trademark of Interlogix, Inc.

## About This Manual

This manual provides information for planning, installing, programming, and testing this security system. When necessary, this manual refers you to other documentation included with compatible devices.

Planning sheets are included for you to record hardware layout and software programming settings.

## Special Installation Requirements

This security system can be used as an intrusion alarm system, a fire alarm system, and an emergency notification system.

Some installations may require configurations dictated by city/state codes, insurance, or Underwriter's Laboratories (UL). This section describes the various component and configuration listings.

## UL Listed Systems

This section describes the requirements for UL Listed systems.

### Basic System

- Control Panel (60-874-95R).
- Standard Class II 8.0 VAC, 300 mA Power Transformer; manufacturer—Sino America, (A1014444-0) ITI Part No. 22-117.
- Dialog Telephone Interface Module (DTIM) (60-879-95R).
- Backup Battery 4.8 VDC rechargeable NiCd battery pack (34-057).

### Household Burglary Alarm System Unit (UL 1023)

Basic system, plus:

- Hardwire Magnetic Contact (13-068 or 13-071) or Wireless Learn Mode Door/Window Sensor (60-362), Wireless Learn Mode PIR Motion Sensor (60-703-95 or 60-639).
- RECEIVER TROUBLE set to on.
- EXIT DELAY set to 60 seconds or less.
- QUICK EXIT set to off.
- SIREN TIMEOUT set to 4 minutes or more.
- ENTRY DELAY set to 45 seconds or less.
- SLEEPY TIME set to off.

### Household Fire Warning System (UL 985)

Basic system, plus:

- Wireless Smoke Sensor (60-506-319.5 or 60-848-95) learned into sensor group 26.
- RECEIVER TROUBLE set to on.
- SLEEPY TIME set to off.
- EXIT EXTENSION set to off.

## Digital Alarm Communicator System (UL 1635)

Basic system, plus:

- AC FAILURE set to on.
- LOW CPU BATTERY set to on.
- AUTO PHONE TEST set to on.
- PHONE TEST FREQUENCY set to one.
- NEXT PHONE TEST set to one.

### Central Station Reporting

The panel has been tested with the following central station receivers using SIA and Contact ID reporting formats:

- ITI CS-5000 Central Station Receiver.
- Sur-Gard Central Station Receiver with models SG-DRL2A and SG-CPM2.

## UL-Canada Listed Systems

This section describes the requirements for ULC (UL Canada) Listed systems.

### CSA Certified Accessories

#### Residential Burglary Alarm System Unit (ULC-S309)

Same as "UL Basic System and Household Burglary Alarm System Unit (UL 1023)."

### California State Fire Marshall Listed Systems

Same as Household Fire Warning System (UL 985).

## Planning the Installation

This section describes the systems's capabilities to help you get familiar with the system. Appendix B provides planning sheets with tables that let you record the hardware and programming configuration of the system to help prepare for system installation.

## Standard System

### Panel

The panel keypad provides complete system programming and operation control. Displays system messages and indicates system status.

### DTIM

The DTIM allows the panel to communicate with the central monitoring station.

#### Note

The DTIM does not have a backup battery.

The following describes the system's basic (out-of-box) hardware capabilities.

- Power: AC Class II, 8 VAC transformer.
- Backup Battery 4.8 VDC rechargeable NiCd battery pack. (34-057)
- One Supervised Hardwire Zone: Input for various hard-

wired detectors.

- Built-In Radio Receiver: Allows use of up to 20 ITI 319.5 MHz. crystal and/or SAW Learn Mode wireless sensors and touchpads.
- Built-In Siren: Capable of 85 dBa @ 3m.
- Built-In Panel Keypad.
- Liquid Crystal Display (LCD).

### Additional System Components

The system can monitor up to 20 sensors using any combination of the following sensors:

- Door/Window Sensor (60-670-95R).
- 2-Button Keychain Touchpad (60-607-319.5).
- Remote Handheld Touchpad (60-671-95R).
- Indoor Motion Sensor (60-639-95R).
- Carbon Monoxide Alarm (60-652-95)\*.
- Smoke Sensor (60-747-95).
- ShatterPro Glass Break (60-873-95)\*.
- Other supported ITI 319.5 Sensors (excluding other touchpads).

**Note**  
Both ITI SAW and Crystal sensors function with this control panel.

## Installing the System

Before starting the installation, plan your system layout and programming using the worksheets provided in Appendix B.

Installing the system consists of the following:

- Determining the Panel Location.
- Mounting the Panel.
- Identifying Main Panel Components.
- Connecting Detection Devices to Panel Zone Input.
- Installing an RJ-31X Phone Jack for the DTIM.
- Connecting the AC Power Transformer.
- Powering Up the Panel.

### Determine the Panel Location

Before permanently mounting the panel, determine panel location using the following guidelines:

- Avoid running wires parallel with electrical wiring or fixtures such as fluorescent lighting, to prevent wire runs from picking up electrical noise.

\*) Not investigated by UL.

- Mount the panel at a comfortable working height (about 45 to 55 inches from the floor to the bottom of the panel).
- Leave space above the panel for optional antenna plastic (min 4 inches).

**Important !**

The panel must be mounted at least 10 feet from any DTIM or between any two DTIMs.

## Mounting the Panel

Use the following procedure to mount the panel to the wall or wall studs.



**CAUTION**

Make sure you are free of static electricity whenever you work on the panel with the back mounting plate removed. Using an approved grounding strap is recommended.

**To mount the panel:**

1. Remove the panel from the back mounting plate by lifting the tab located on the top and pulling back.

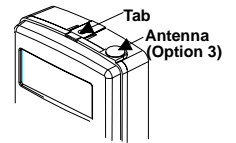

**Figure 1. Remove back by lifting tab**

2. Remove the wiring knockout.

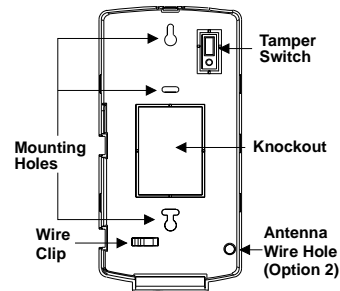

**Figure 2. Back Mounting Plate**

3. Feed all device wires through the knockout and place the back mounting plate in position against the wall.
4. Level the back mounting plate and mark the top and bottom mounting holes.
5. Install anchors where studs are not present.
6. Partially insert a screw into the top mounting hole location then hang the back mounting plate on the screw.
7. Recheck for level, insert the lower screw, and tighten both mounting screws.
8. Install the antenna. There are three antenna options to choose from:

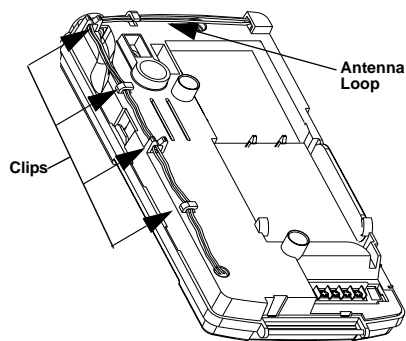

Figure 3. Antenna wiring as shipped

- ❑ **Option 2:** Hang antenna in wall (longest range).
  - When you mark the back mounting plate's two mounting holes, also mark where the antenna hole is (see Figure 2 for antenna wire hole location).
  - Where the antenna hole was marked, drill a hole into the wall.
  - Remove the antenna loop (see Figure 3) from the panel cabinet clips and feed through the antenna hole and down into the wall.

- ❑ **Option 3:** Optional antenna housing (included in accessory pack) and attach it to the panel (medium range).
  - Push the antenna housing down into the top-right hole of the panel until it snaps into place (see Figure 4).
  - Remove the antenna loop from the last clip on the panel cabinet and insert it into the antenna housing.

9. Place panel cabinet into back mounting plate and snap into place.

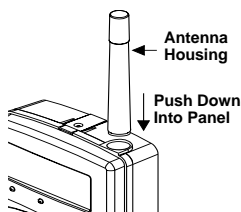

Figure 4. Optional Antenna Housing

### Connecting Detection Devices to Panel Zone Inputs

Zone input is supervised using a 2k-ohm, end-of-line (EOL) resistor (included with panel) at the last device on the circuit. It accepts either normally open (N/O) or normally closed (N/C) detection devices.

The maximum loop resistance for each zone input is 300 ohms, plus the 2k EOL resistor.

### Connecting Intrusion Detection Devices

Figure 5 shows the typical wiring for N/C and N/O door/window intrusion detection.

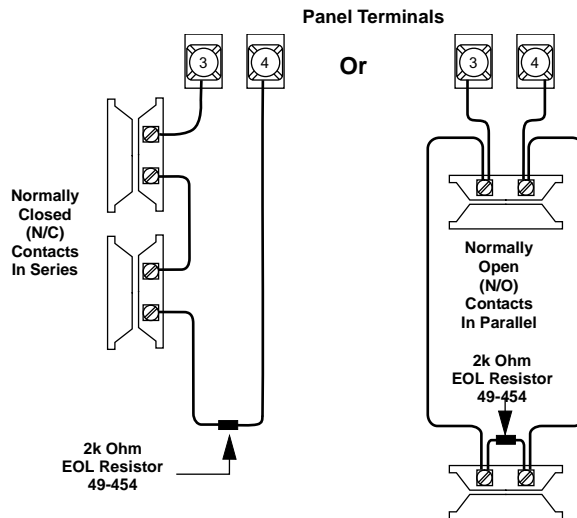

Figure 5. Wiring N/O or N/C Intrusion Detection devices

### Connecting the AC Power Transformer (22-117)

The panel must be powered by a plug-in stepdown transformer that supplies 8 VAC, 300 mA.

Connect the power transformer to the panel as shown in Figure 6.

#### CAUTION

Do not plug in the power transformer at this time. The panel must be powered up using the sequence of steps described in the "Powering Up the Panel" section

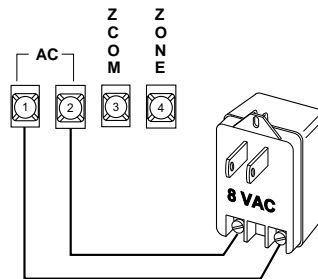
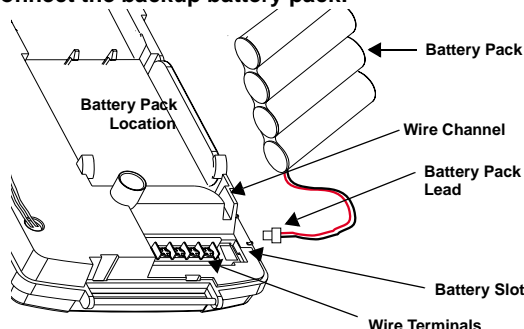

Figure 6. Connecting a Power Transformer

### Connecting the Backup Battery Pack

The panel will receive its primary power from an AC class II transformer. In the event of an AC power failure, the panel will be powered by a battery pack containing four rechargeable NiCd batteries.

**To connect the backup battery pack:**



**Figure 7. Connecting the Battery Pack**

1. Remove the panel housing from the back mounting plate by lifting the tab located on the top of the panel and pulling back.
2. Slide the battery pack into the space provided on the back of the panel (Figure 8).

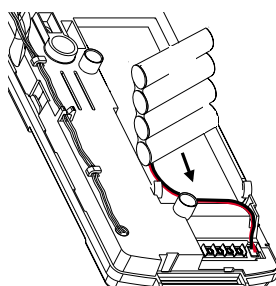

**Figure 8. Placement of Battery**

3. Plug the battery pack lead into the slot provided next to the wire terminals (Figure 7).

**Note**

Be sure to run the battery pack wires below the battery and thru the wire channel.

4. Replace the panel housing into back mounting plate and snap into place.

**Note**

See Appendix A: Troubleshooting on page 19 if the panel displays LOW BATTERY.

**Powering Up the Panel**

After connecting and wiring all devices to the panel, you are ready to apply AC power to the panel.

**To power up the panel:**

- Plug the transformer into an outlet that is not controlled by a switch or ground fault circuit interrupt (GFCI). Be sure to screw the top of the transformer onto the outlet so that doesn't fall out of the outlet.
- The message, PANEL POWERED UP, will be displayed

**⚠ WARNING**

Be careful when securing the transformer to an outlet with a metal cover. Hold the cover tightly in place. You could receive a serious shock if the metal outlet cover drops down onto the prongs of the plug while you are securing the transformer and cover to the outlet box.

**Note**

If the panel does not display anything, immediately unplug the transformer and disconnect the backup battery. Refer to the "Troubleshooting" (on page 19) section.

**Programming the Panel**

This section describes how to program all settings found in programming mode. You can program the panel manually

using the panel keypad to program on site. Or, using the ToolBox software, you can automatically program remotely via a modem and phone line.

**Panel Keypad Button Programming Functions**

In program mode, panel keypad buttons let you navigate to all installer programming menus for configuring the system. Table 1 describes the panel keypad button functions in program mode.

**Table 1: Button Functions**

Button	Programming Function
	Selects menu item or data entry. Toggles between on and off whenever needed.
	Deselects menu item or data entry (if pressed before #).
	Scroll through available options at the current menu tier.
0 thru 9	Enter numeric values wherever needed.

**Moving Through Program Mode Tiers and Menus**

There are three tiers of programming menus. Tier 1 menus are accessible immediately after entering program mode.

In Figure 9 arrows pointing right represent pressing ▼ to advance forward through the menus. Arrows pointing left represent pressing ▲ to move through the menus in reverse.

The arrows below the tier 1 menu represents pressing # and \* buttons.

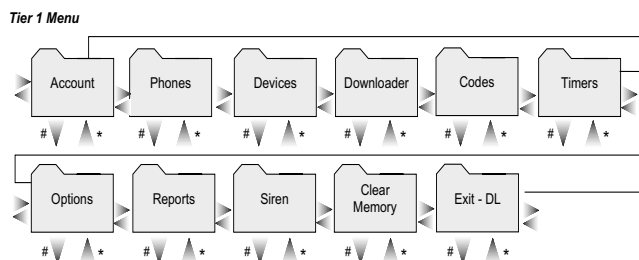

**Figure 9. Tier 1 Programming Menus**

To advance to tier 2 program menus press the up or down arrow keys to scroll thru the tier 1 menus. When you find the menu you want to make changes to press # once. This will take you to tier 2 program menus.

**Installer Programming Menu Items**

This section guides you through the installer programming menu items as they appear in sequence with the exception of clearing memory.

**Entering Installer Programming Mode**

Entering programming mode on site is done from the panel, using an installer code. The default installer code is

4321. The system can be put into program mode only when the system is disarmed.

**To enter programming mode:**

With the system disarmed, press **[\*] + [0][0][\*]**.

**To clear memory:**

It is strongly recommended that you clear memory on all newly installed panels before programming.

Clearing Memory 1st Tier	(Clear Memory)
<p>(Default = none) Clear memory deletes all existing programming information and then resets the panel settings to their default settings. The dealer code is not erased when panel memory is cleared.</p>	
<p><b>To clear panel memory:</b></p> <ol style="list-style-type: none"> <li>1. Press <b>[*]</b>, and enter the dealer or installer code. The display shows ACCOUNT.</li> <li>2. Press <b>[▲]</b> twice. The display shows EXIT - DL; CLEAR MEMORY.</li> <li>3. Press <b>#</b>.</li> <li>4. Enter code to clear memory. After a few seconds the system restarts and the message PANEL POWERED UP is displayed.</li> </ol>	

**Learning the DTIM into the Panel**

The module learns in using the 3-2-1 procedure similar to the encrypted key fob. There is no time limit between learn in attempts. The LED will blink when the correct number of tamper switch presses have been entered. Be sure to wait for the LED to turn off after each flash. The tamper switch sequence of 3-2-1 must be mirrored by the LED for the user to continue.

**Important !**

Do not wait more than 1-2 seconds between steps 5 and 6 or steps 6 and 7 after releasing the tamper switch. If you wait too long between these steps, the LED will not flash and you will have to start over.

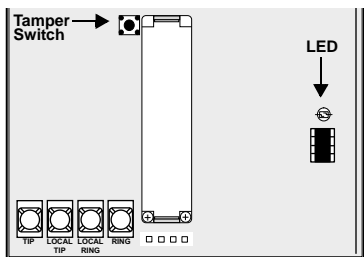

Figure 10. DTIM Tamper Switch and LED Locations

**To learn the DTIM into the panel:**

1. Remove the DTIM cover.
2. Press **[▼]** twice and **#** once. The display shows PHONES; DEVICES; ADD.
3. Press **#**. The display shows ZONE 01 - TRIP.

**Note**

The DTIM is normally learned into zone 01, Phone Module.

4. Press the DTIM's tamper switch three times, holding the tamper switch down on the third press and wait for the LED to flash three times. Release the tamper switch after the third flash.
5. Press the DTIM tamper switch twice, holding the tamper switch down on the second press and wait for the LED to flash two times. Release the tamper switch after the second flash.
6. Press and hold the tamper switch down until the LED flashes once. The panel beeps once indicating the DTIM was learned into the panel.

Once the DTIM has been learned into the panel, proceed to programming the rest of the panel.

**Account Menu (1st Tier)**

The account menu lets you set up the account number used for customer identification for the central monitoring station.

Account 1st Tier
<p>(Default = 00000, Parameters = 4-10 digits; 0-9, A-F) The account number is used as panel (or customer) identification for the central monitoring station. The panel sends the account number every time it reports to the central station. Account numbers must be 4 to 10 characters long.</p> <p>Alpha characters A-F can be assigned to the account number by pressing and holding buttons 1-6 respectively, until the character appears.</p>
<p><b>Note</b> The CID format only supports account numbers with letters B through F, or numbers 0 through 9 (or a combination of those letters and numbers).</p>
<p><b>To program an account number:</b></p> <ol style="list-style-type: none"> <li>1. Press <b>#</b>, then enter the 4-10 digit code (0-9 and A-F) and press <b>#</b>.</li> </ol>



**Phones Menu (1st Tier)**

The phone menu lets you set up central station reporting for the system.

**Number 1 and 2 (Phones—Phone 1 and Phone 2)  
3rd Tier**

(Default = none, Parameters = 24 digits; 0-9, \*, #) This setting is used for programming the central station receiver phone number. Phone numbers can be 1 to 24 digits long, including pauses or \* and # characters.

To enter pauses, press the silent key. A pause is displayed as P.

To enter \*, press and hold the 7 key until \* appears. A star (\*) is displayed as \*.

To enter #, press and hold the 9 key until + appears. A pound (#) is displayed as +.

**Note**

The phone numbers are not accessible if a Dealer Code is programmed and the Installer Code is used to enter installer programming mode. To access these numbers when a Dealer Code is programmed, you must enter installer programming mode using the Dealer Code.

**Note**

Call-waiting services should be disabled to prevent interrupting panel communication to the central monitoring station. To program a dialing prefix that disables call-waiting, see *Pre-Dial String on page 8*.

**To program number 1/2:**

- Enter 1-24 digit number and press #.

**FMT - CID (Phones—Phone 1 and Phone 2)  
3rd Tier**

(Default = CID) This setting determines whether the panel uses the SIA (off) or CID (on) reporting format for central station communication.

**To select reporting format under phone 1/2:**

- Press # to select on or off.

**High Lvl (Phones—Phone 1 and Phone 2)  
3rd Tier**

(Default = Phone 1: on, Phone 2: off) When High Level Reporting is on, the following conditions report to the central station:

- Fire, Police, Emergency, and Duress alarms
- Phone Test
- Receiver Trouble
- Entering or Exiting Sensor Test Mode
- Tamper Conditions, including Zone Tamper and System Tamper (40 incorrect key presses)
- No Activity

See Table B4: “Central Station Reports,” on page 27 for a complete list of reports.

**Note**

For UL listed installations, High and Low-level reports must be set to on.

**To turn high-level reports on or off under phone 1/2:**

- Press # to turn it on or off.

**Low Lvl (Phones—Phone 1 and Phone 2)  
3rd Tier**

(Default = Phone 1: on, Phone 2: off) When this setting is on, the following non-alarm conditions report to the central station:

- Forced Arming
- Hardwire Zone Trouble
- RF Supervisory
- RF Low Battery
- Phone Test

See Table B4: “Central Station Reports,” on page 27 for a complete list of reports.

**To turn low-level reports on or off under phone 1/2:**

- Press # to turn it on or off.

**Openings (Phones—Phone 1 and Phone 2)  
3rd Tier**

(Default = off) This setting determines whether an opening report is sent to the central station. When turned on, the panel sends an opening report when the system is disarmed.

**To turn opening reports on or off under phone 1/2:**

- Press # to turn it on or off.

**Closings (Phones—Phone 1 and Phone 2)  
3rd Tier**

(Default = off) This setting determines whether a closing report is sent to the central station. When turned on, the panel sends a closing report when the system is armed.

**To turn closing reports on or off under phone 1/2:**

- Press # to turn it on or off.

**Backup (Phones—Phone 2)  
3rd Tier**

(Default = on) This setting determines whether the DTIM uses phone number 2 for reporting if three initial attempts on phone number 1 are unsuccessful. PHONE 1 is backed up by PHONE 2. The DTIM makes up to 16 attempts (8 per phone number), alternating between the two programmed phone numbers.

For example, if Backup is on and three failed reporting attempts occur using PHONE 1, (panel displays PHONE 1 FAIL), the DTIM switches to PHONE 2 for three more reporting attempts. If these attempts fail, (panel displays PHONE 2 FAIL), the DTIM switches back to PHONE 1 for five more reporting attempts and, if necessary, switches back to PHONE 2 for five final attempts. If these final attempts fail, the panel will display PHONE FAILURE.

**To turn backup on or off:**

- Press # to turn it on or off.

**Dial Dly** (Phones)  
2nd Tier

(Default = 30 seconds, Parameters = 15-120 seconds) Dial Delay determines how much time the user has to stop a panel before it sends a false alarm to the central station.

Alarm reports from sensors in groups 00-03, 10, and 13-20 can be aborted. To abort the dialing attempt, the user must disarm the system within the Dial Dly time setting. Cancel and restoral reports from these sensor groups are aborted at the same time. The following reports can also be aborted.

- System Tamper Alarm/Cancel.
- Touchpad Police and Emergency Panic/Cancel.
- Forced Arming
- Recent Closing and Two Trip Error.

**Note**  
Fire alarm reports to the central station cannot be aborted.

**To set the dial dly:**

- Enter the desired amount of time (15-120 seconds) and then press #.

**Pre-Dial String** (Phones)  
2nd Tier

(Default = none, Parameters = 8 digits; 0-9, \*, #, pause) This feature lets you set up a dialing prefix to disable the call waiting feature before the panel makes its first dialing attempt to any programmed central monitoring station or downloader phone number. The prefix can be up to eight digits. Contact your local phone company for call waiting disable numbers and characters. See Number 1 and 2 programming on page 7 for information on how to program \* and # characters.

**Note**  
The pre-dial string is not accessible if a Dealer Code is programmed and the Installer Code is used to enter installer programming mode. To access the pre-dial string option when a Dealer Code is programmed, you must enter installer programming mode using the Dealer Code.

**To set the pre-dial string:**

- Enter the desired numbers and then press #.

**DTMF Dial** (Phones)  
2nd Tier

(Default = on) This setting determines whether the panel uses DTMF tones (on) or pulse (off) for dialing programmed phone numbers.

**To turn DTMF dialing on or off:**

- Press # to turn it on or off.

**Devices (1st Tier)**

(Default = none) Devices include a HW sensor, RF sensors, RF touchpads, and other RF devices such as the DTIM.

**Table 2: Sensor Group Assigned to Device**

Device	Sensor Group
Keyfob or RF Touchpad	1
Portable Panic	1
HW Input	10
DWS	10
PIR	17
Sound	17
Glassguard	17
Smoke	26
Rate of Rise	26
DTIM	36

**Table 3: Device Programming**

Device	To Program
Door/Window Sensor (SAW)	Press button on top of sensor (cover removed).
Motion Sensor	Press button on back of sensor (mounting plate removed).
Keychain Touchpad (non encrypted)	Press lock & unlock buttons until LED blinks.
Keychain Touchpad (encrypted)	See Note.
Crystal Sensors	See Note.
DTIM	3-2-1 sequence (on page 6).
Hardwire Sensor	For normally closed - separate sensor from magnet.  For normally opened - close sensor then reopen.
<b>Note</b> When installing crystal sensors and encrypted keychain touchpads, use the installation instructions included in their packing boxes.	

**Add** (Devices)  
2nd Tier

(Default = none) When adding devices, the panel will automatically assign the device to a sensor group based on the type of device. Table 2 outlines the sensor group assigned to each device.

**Note**  
To override the preassigned sensor number, use the arrow keys to skip to the desired sensor number.

**To add a device:**

1. Press #. The display shows ZONE {01- 20} - TRIP.
2. Trip the sensor (see Table 3). The panel beeps twice to indicate the sensor was successfully learned into the panel.
3. Repeat step 2 until all desired zones are added.

Delete 2nd Tier	(Devices)
<p>(Default = none) The following procedure describes how to remove hardwire and wireless sensors from panel memory.</p> <p><b>Note</b> Deleting zones/sensors does not delete text associated with the deleted zone/sensor number.</p> <p><b>To delete a device:</b></p> <ol style="list-style-type: none"> <li>To select a different zone press ▼ to scroll thru the learned zones. Press # to delete the displayed zone. The display shows the next sensor.</li> <li>Repeat step 1 until all desired zones are deleted.</li> </ol>	

Review 2nd Tier	(Devices)
<p>(Default = none) This allows you to view the zone number and the group for each learned zone or sensor. For example, the display shows:</p> <p style="margin-left: 40px;">ZONE 01 GRP 10</p> <p>where:</p> <p>ZONE 01 = zone/sensor number, GRP 10 = sensor group 10.</p> <p>Review devices allows the installer to change the group assigned to devices. The panel accepts the group numbers defined in Table B1 in Appendix B.</p> <p><b>To review a device:</b></p> <ol style="list-style-type: none"> <li>To select a different zone press ▼ to scroll thru the learned zones. The display shows the current setting.</li> <li>Enter the desired group number to modify then press #. The display shows the new setting.</li> </ol>	

Text 2nd Tier	(Devices)
<p>(Default = none) The panel allows sensor text to be associated with each device. The sensor text consists of a prefix field, base field, and suffix field. Table 4 shows the words available for each field. The default text for zones 1-3 are:</p> <ul style="list-style-type: none"> <li><input type="checkbox"/> Zone 1 - Phone Module (DTIM)</li> <li><input type="checkbox"/> Zone 2 - Front Door</li> <li><input type="checkbox"/> Zone 3 - Back Door</li> </ul> <p><b>To add text:</b></p> <ol style="list-style-type: none"> <li>To select the zone you want to add text to press ▼, till you get to the correct zone then press #. Base is the first to be displayed.</li> <li>Press # then ▼ to scroll thru the base words, press # to select the word you want.</li> <li>Press ▼ to change to the prefix words. Press # then ▼ to scroll thru the prefix words. Press # to select the word you want.</li> <li>Press ▼ to change to the suffix words. Press # then ▼ to scroll thru the suffix words. Press # to select the word you want.</li> <li>Press * to review what has been selected, then press ▼ to go to the next zone to change.</li> <li>Repeat steps 2 thru 4 to change all zones.</li> </ol>	

**Table 4: Sensor Text**

Prefix Field	Base Field	Suffix Field
None	None	None
North	Keychain	Door
NE	Touchpad	Window
East	Front	Remote
SE	Back	Smoke
South	Garage	Emergency
SW	Bedroom	Motion
West	Guest Room	Fire
NW	Childs Room	Freeze
	Utility Room	CO
	Living Room	0
	Dining Room	1
	Bathroom	2
	Laundry Room	3
	Kitchen	4
	Office	5
	Den	6
	Special Chime	7
	Basement	8
	Upstairs	9
	Downstairs	
	Hallway	
	Medicine Cabinet	
	Closet	
	Attic	
	System Panic	
	Phone Module	

**Note**  
Some combinations of the sensor text selections are too long for the display.

**Downloader (1st Tier)**

Number 2nd Tier	(Downloader)
<p>(Default = none, Parameters = 24 digits; 0-9, *, #, pause) Use this setting to enter the phone number of an off-site computer that can be used to program the panel through the phone line. Phone numbers can be 1 to 24 digits long, including pauses or * and # characters (see Number 1 and 2 (Phones—Phone 1 and Phone 2) on page 7).</p>	
<p><b>Note</b> The phone numbers are not accessible if a Dealer Code is programmed and the Installer Code is used to enter installer programming mode. To access these numbers when a Dealer Code is programmed, you must enter installer programming mode using the Dealer Code.</p>	
<p><b>Note</b> For this feature to work, the DTIM must be connected to a phone line with a Downloader phone number, and with a Downloader code.</p>	
<p><b>Note</b> Call-waiting services should be disabled to prevent interrupting panel communication to the downloader. To program a dialing prefix that disables call-waiting, see the <i>Pre-dial String</i> setting on page 8.</p>	
<p><b>To program a downloader number:</b></p> <p><input type="checkbox"/> Enter 1-24 digit number and then press #.</p>	

DL Code 2nd Tier	(Downloader)
<p>(Default = 12345, Parameters = 5 digits; 0-9) The 5-digit downloader code is used in conjunction with downloader programming. The downloader operator must have the panel account number, dealer code, and downloader code in order to perform any programming.</p>	
<p><b>Note</b> The Downloader Code cannot be deleted from panel memory. To change the Downloader Code to its default setting, enter 12345 when programming the Downloader code.</p>	
<p><b>To program a downloader code:</b></p> <p><input type="checkbox"/> Enter 5-digit code and then press #.</p>	

**Codes (1st Tier)**

Install Code 2nd Tier	(Codes)
<p>(Default = 4321, Parameters = 4 digits; 0-9) The 4-digit installer code is used for entering program mode and changing system settings. If a dealer code is programmed, all settings except phone numbers, pre-dial string, and downloader number and dealer code can be changed.</p>	
<p><b>To change an installer code:</b></p> <p><input type="checkbox"/> Enter 4-digit code and then press #.</p>	

Dealer Code 2nd Tier	(Codes)
<p>(Default = none, Parameters = 4 digits; 0-9) The 4-digit dealer code is used to prevent unauthorized persons from changing the programmed central station phone numbers. When this feature is enabled, central station phone numbers, pre-dial string, and downloader phone number cannot be changed (unless you enter the program mode by using the dealer code). All other system settings are still accessible by entering program mode with the installer code.</p>	
<p><b>Note</b> When memory is cleared the dealer code will not be deleted from panel memory.</p> <p>If a dealer code has already been programmed into the system, use that code to change the dealer code.</p>	
<p><b>To program a dealer code:</b></p> <p><input type="checkbox"/> Enter 4-digit code and then press #.</p>	
<p><b>To delete a dealer code:</b></p> <p><input type="checkbox"/> Press # twice, once to delete code and then again to accept the command.</p>	

Duress Code 2nd Tier	(Codes)
<p>(Defaults = none, Parameters = 4 digits; 0-9) The duress code is a unique 4-digit access code that allows users to operate the system and, at the same time, instructs the panel to send a silent alarm report to the central station.</p>	
<p><b>To program a duress code:</b></p> <p><input type="checkbox"/> Enter 4-digit code and then press #.</p>	

Apartment Manager 2nd Tier	(Codes)
<p>(Default = none, Parameters = 4 digits; 0 to 9) The apartment manager code functions the same as the primary code within the user programming menu, and can arm or disarm the system.</p>	
<p><b>To program apartment manager code:</b></p> <p><input type="checkbox"/> Enter 4-digit code and then press #.</p>	
<p><b>To delete the apartment manager code:</b></p> <p><input type="checkbox"/> Press # twice, once to delete code and then again to accept the command.</p>	

**Timers (1st Tier)**

<b>Entry Dly</b> 2nd Tier	<i>(Timers)</i>
<p>(Default = 30 seconds, Parameters = 30-240 seconds) Entry Delay determines how much time the user has to disarm the system after entering the armed premises through a “designated delay door,” (grp 10) without causing an alarm.</p> <p><b>Note</b> For UL Listed installations, the Entry Delay must be set to 45 seconds or less.</p> <p><b>To set the entry delay:</b></p> <p><input type="checkbox"/> Press #, enter desired time and then press #.</p>	

<b>Exit Dly</b> 2nd Tier	<i>(Timers)</i>
<p>(Default = 60 seconds, Parameters = 45-254 seconds) Exit Delay determines how much time the user has after arming the system to leave the premises through a “designated delay door,” (group 10 or 19) without causing an alarm.</p> <p><b>Note</b> For UL Listed installations, the Exit Dly must be set to 60 seconds or less.</p> <p><b>To set the exit delay:</b></p> <p><input type="checkbox"/> Press #, enter desired time and then press #.</p>	

<b>Phone Test Frequency</b> 2nd Tier	<i>(Timers)</i>
<p>(Default = 7 days, Parameters = 1-255 days) Phone Test Frequency determines how often the panel conducts the automatic phone test. The system can be set to perform an automatic phone test anywhere from every day to every 255 days. To turn this option off, turn off Auto Phone Test under the Reports option.</p> <p><b>Note</b> For UL Listed installations, the Next Phone Test and Phone Test Frequency must be set to 1.</p> <p><b>To set the phone test frequency:</b></p> <p><input type="checkbox"/> Press #, enter desired number of days and then press #.</p>	

<b>Next Phone Test</b> 2nd Tier	<i>(Timers)</i>
<p>(Default = 7 days, Parameters = 1-255 days) Next Phone Test is used by the Auto Phone Test feature to determine when the next automatic phone test should occur. This setting should be the same as, or less than, the Phone Test Frequency setting. To turn this option off, turn off Auto Phone Test under the Reports option.</p> <p><b>To set the next phone test:</b></p> <p><input type="checkbox"/> Press #, enter desired time (1-255 days) and press #.</p>	

<b>Sleepy Time</b> 2nd Tier	<i>(Timers)</i>
<p>(Default = on) Sleepy Time determines whether sleep hour is enabled or disabled. If enabled, proceed to Sleep Hour to set the sleep time desired.</p> <p><b>Important !</b> Fire related trouble beeps are not affected by Sleepy Time.</p> <p><b>Note</b> For UL Listed installations the Sleepy Time option must be set to off.</p> <p><b>To set the sleepy time:</b></p> <p><input type="checkbox"/> Press # to turn on or off.</p>	

<b>Sleep Hour</b> 2nd Tier	<i>(Timers)</i>
<p>(Default = 22, Parameters = 0-23) Sleep Hour determines the start time of a 10 hour window during which trouble beeps are suppressed. For example, if sleep time is set to 22 (10 p.m.) then non-fire related trouble beeps will not start between 10 p.m. and 8 a.m.</p> <p><b>To set the sleep hour:</b></p> <p><input type="checkbox"/> Enter desired time (00-23) and then press #.</p>	

**Options (1st Tier)**

<b>KTP Arm</b> 2nd Tier	<i>(Options)</i>
<p>(Default = off) When Keychain Touchpad Arm is on, pressing the lock button on keychain touchpads arms the system directly with NO DELAY.</p> <p>When this setting is off, each key-press increments the arming level without NO DELAY.</p> <p><b>To turn keychain touchpad arm on or off:</b></p> <p><input type="checkbox"/> Press # to turn on or off.</p>	

<b>Police Panic</b> 2nd Tier	<i>(Options)</i>
<p>(Default = on) This setting determines whether panel keypad police panic buttons are enabled (on) or disabled (off). If enabled, an immediate Police alarm will occur after the police panic buttons are pressed for two seconds and the panel displays the alarm as a police panic. If the DTIM is installed with the system;</p> <p><input type="checkbox"/> An alarm report will be issued.</p> <p><input type="checkbox"/> If the dialer delay option is on, the report will be delayed or can be aborted.</p> <p><b>To turn the police panic on or off:</b></p> <p><input type="checkbox"/> Press # to turn on or off.</p>	

**Emergency Panic** (Options)  
2nd Tier

(Default = off) This setting determines whether panel keypad emergency panic buttons are enabled (on) or disabled (off). If enabled, an immediate alarm will occur after the emergency panic buttons are pressed for two seconds and the panel displays the alarm as an emergency panic. If the DTIM is installed with the system;

- An alarm report will be issued.
- If the dialer delay option is on, the report will be delayed or can be aborted.

**To turn the emergency panic on or off:**

- Press # to turn on or off.

**Fire Panic** (Options)  
2nd Tier

(Default = on) This setting determines whether panel keypad fire panic buttons are enabled (on) or disabled (off). If enabled, an immediate Fire alarm will occur after the fire panic buttons are pressed for two seconds and the panel displays the alarm as a fire panic. If the DTIM is installed with the system, an immediate alarm report will be issued.

**Note**  
The alarm report cannot be aborted or cancelled.

**To turn the fire panic on or off:**

- Press # to turn on or off.

**Rcvr Trouble** (Options)  
2nd Tier

(Default = off) When Receiver Trouble is on, the panel reports a receiver failure under the following conditions:

- A wireless sensor signal has not been received for two hours or
- The receiver is being jammed with a constant signal.

**Note**  
For UL Listed installations using wireless devices, Receiver Trouble must be set to on.

**To turn receiver trouble reports on or off:**

- Press # to turn on or off.

**Panel Tamper** (Options)  
2nd Tier

(Default = on) Panel Tamper determines how the panel handles possible tamper situations. When this feature is on, the panel reports a panel tamper if the panel back cover or DTIM cover is opened while the panel is armed. A police alarm will sound and PANEL TAMPER will be displayed. If this feature is off, the panel will display a status message only.

**To turn the panel tamper on or off:**

- Press # to turn on or off.

**Exit Ext** (Options)  
2nd Tier

(Default = on) When Exit Extension is on, the panel restarts the exit delay timer if the user re-enters the premises through a standard delay door before the standard exit delay time expires.

This helps prevent exit faults and false alarms by allowing users to re-enter the premises for a forgotten item.

When this feature is off, the exit delay timer does not restart if the user re-enters the premises, forcing the user to disarm the system to avoid setting off an accidental alarm.

**Note**  
For UL Listed Installations the Exit Extension option must be set to off.

**To turn exit extension on or off:**

- Press # to turn on or off.

**Swinger Shutdown** (Options)  
2nd Tier

(Default = 1, Parameters = 1-2) This setting determines the maximum number of times a sensor or zone can go into alarm (during a single arming period) before the panel automatically bypasses that sensor or zone. This feature only applies to sensors or zones in groups 0, 1, 4, 6, 8-10, and 13-23.

When set to 1, the panel automatically bypasses a sensor or zone after it causes an alarm. When set to 2, the panel waits until a sensor or zone has caused a second alarm (during the same arming period) before bypassing it. At any setting, the automatic bypass is logged into the event buffer and can only be viewed thru ToolBox.

The bypassed sensor or zone will be cleared (automatically unbypassed) if the system receives no further activations from that sensor or zone over the next 48-50 hours.

Changing the arming level also clears all bypassed sensors and zones and resets the Swinger Limit count on all sensors and zones.

**To set the swinger shutdown:**

- Press #, enter desired number and then press #.

**Quick Arm** (Options)  
2nd Tier

(Default = off) Quick Arm allows system arming without using an access code. When Quick Arm is on, the system arming level can be increased without entering an access code.

A valid access code is still required to disarm the system.

**To turn quick arm on or off:**

- Press # to turn on or off.

Quick Exit 2nd Tier	<i>(Options)</i>
<p>(Default = on) This setting determines whether or not users can open and close a standard entry/exit door without causing an alarm (while the system is armed).</p> <p>When Quick Exit is on, (while the system is armed) pressing the Quick Exit button starts a 2-minute timer that allows exit/entry thru one standard entry/exit door (sensor group 10) to be activated (opened, then closed) for 2 minutes.</p> <p>When this feature is turned off, the system must be disarmed if a protected door is opened.</p> <p><b>Note</b> For UL Listed installations, this feature must be set to off.</p> <p><b>To turn quick exit on or off:</b></p> <p><input type="checkbox"/> Press # to turn on or off.</p>	

Auto Stay Arm 2nd Tier	<i>(Options)</i>
<p>(Default = on) This setting determines whether or not the system automatically arms only doors and windows if the user arms the system without exiting the premises. This can help prevent accidental alarms by deactivating interior motion sensors during occupied arming periods.</p> <p>When this feature is on and the system is armed, the display counts down the exit delay time. If the exit delay time expires with no group 10 sensor activation, the system automatically arms to Level 2, doors and windows.</p> <p><b>Note</b> Arming the system to "Level 3 with No Delay" overrides the Auto Stay Arming feature.</p> <p><b>To turn auto stay arm on or off:</b></p> <p><input type="checkbox"/> Press # to turn on or off.</p>	

Supv Time 2nd Tier	<i>(Options)</i>
<p>(Default = random, Parameters = 1:00 am - 5:00 am) Supervisory Time determines what time of day the panel sends supervisory, low battery, and auto phone test reports to the central station.</p> <p><b>Note</b> The panel clock must be set with the correct time for accurate supervisory time reporting. See programming Time (Time) on page 16.</p> <p><b>To set the supervisory time:</b></p> <p><input type="checkbox"/> Press #, enter desire time, use scroll keys to select am or pm, and then press #.</p>	

Alarm Verify 2nd Tier	<i>(Options)</i>
<p>(Default = off) This setting determines whether the panel reports to the central monitoring station after a single sensor or zone trip (off) or waits for a second trip before reporting (on).</p> <p><b>Note</b> The first trip of a sensor will be a local alarm (doesn't call in), the second trip must be a different sensor within 4 minutes of the first trip.</p> <p>This setting affects sensors/zones in groups 10 through 20. If Alarm Verify is set to on, group 18 responds the same as group 17.</p> <p><b>Note</b> For UL Listed installations, Alarm Verify must be set to off.</p> <p><b>To turn alarm verify on or off:</b></p> <p><input type="checkbox"/> Press # to turn on or off.</p>	

**Demo Kit 2nd Tier** (Options)

(Default = off) This setting determines whether the panel is used for a standard installation (off) or as a demo kit (on). The demo kit will include:

- Allegro panel
- SAW D/W
- 2 button key fob
- PIR plastic (motion sensor)
- DTIM plastic
- 9V alkaline battery with battery strap
- Soft-sided case
- Demo kit Instructions

The following contains the modifications to Allegro Software that embody the Demo Kit Software. All features work exactly as on the production version except those listed here.

**Power Up Default Deviations**

The power-up defaults are the same as the production version except the following:

**Zones**

Zone Number	Text
<input type="checkbox"/> 1	KEYCHAIN REMOTE
<input type="checkbox"/> 2	FRONT DOOR

**Miscellaneous**

Item	Default
<input type="checkbox"/> Demo kit	ON
<input type="checkbox"/> CPU low battery	OFF
<input type="checkbox"/> Quick arming	ON
<input type="checkbox"/> Panel panics	ON
<input type="checkbox"/> Entry delays	8 seconds
<input type="checkbox"/> Exit delays	8 seconds
<input type="checkbox"/> Siren time-out	1 minute
<input type="checkbox"/> Trouble beeps	OFF
<input type="checkbox"/> Panel tamper	OFF

All program items can be changed by the operator but will return to defaults upon a memory clear execution.

**Behavioral Differences**

A transformer is not required for the Demo Kit. AC power tests will never be performed and AC power failure will never be shown.

The prompt for setting time after a power cycle will never be shown.

**Reports (1st Tier)**

**AC Fail 2nd Tier** (Reports)

(Default = off) When AC Failure is on, the panel reports to the central station 15 minutes after AC power to the panel is lost.

**Note**  
For UL Listed installations, AC Failure must be set to on.

**To turn AC failure reports on or off:**

- Press # to turn on or off.

**Low CPU Battery 2nd Tier** (Reports)

(Default = on) When this setting is on, the panel reports a low panel battery to the central station before shutting down.

**Note**  
Panel will not call in a low CPU battery within the first 24 hours of being powered up.

**Note**  
For UL Listed installations, the Low CPU Battery feature must be set to on.

**To turn low CPU battery reports on or off:**

- Press # to turn on or off.

**Phone Test 2nd Tier** (Reports)

(Default = on) This setting determines if the user can, at any time when disarmed, test the communication between the panel and the central station. If a DTIM is installed with the system:

- The panel sends a packet to the DTIM informing it to send a phone test report to the central station. The report will be sent out immediately.
- The DTIM will send a successful or failed phone test message to the panel.
- The panel will display PHONE TEST FAILURE, if the phone test is unsuccessful.
- The panel will display TEST PASS, if the phone test is successful.
- If a central station phone number is not programmed the panel will not display the option to do a phone test.
- If a DTIM is not enrolled the panel will not display the option to do a phone test.
- High or Low level reporting must be on.

**To turn the phone test setting on or off:**

- Press # to turn on or off.



<b>Auto Phone Test</b> 2nd Tier	<i>(Reports)</i>
<p>(Default = off) This setting determines if the panel sends a phone test automatically to the central station at Supervisory Time. Refer to the “Phone Test Frequency” and “Next Phone Test” on page 11.</p> <p><b>Note</b> For UL Listed installations, the Auto Phone Test feature must be set to on.</p> <p><b>To turn automatic phone test on or off:</b></p> <p><input type="checkbox"/> Press # to turn on or off.</p>	

**Siren (1st Tier)**

<b>Siren Time Out</b> 2nd Tier	<i>(Siren)</i>
<p>(Default = 4 minutes, Parameters = 1-30) Siren Time-out determines how long sirens sound if no one is present to disarm the system.</p> <p><b>Note</b> For UL Listed installations, the Siren Time-out must be set to 4 minutes or more.</p> <p><b>To set siren time out:</b></p> <ol style="list-style-type: none"> <li>1. Press #, enter the desired time and then press #.</li> </ol>	

<b>Trouble Beeps</b> 2nd Tier	<i>(Siren)</i>
<p>(Default = on) When this setting is on, the panel will beep to alert users of system trouble.</p> <p><b>Note</b> For UL Listed installations, Trouble Beeps must be set to on.</p> <p><b>To turn trouble beeps on or off:</b></p> <p><input type="checkbox"/> Press # to turn on or off.</p>	

<b>Alarm Volume</b> 2nd Tier	<i>(Siren)</i>
<p>(Default = 6, Parameters = 0 to 6) This setting allows you to adjust the panel’s siren volume. The volume can be set from 0 to 6, with 0 being the lowest volume.</p> <p><b>Note</b> Alarm Volume must be set to 6 for UL installations.</p> <p><b>To set the alarm volume:</b></p> <ol style="list-style-type: none"> <li>1. Press #, enter the desired volume level and then press #.</li> </ol>	

**Exit - DL (1st Tier)**

If Exit is selected, the panel returns to active mode. If the installer/dealer code is entered, a downloader session will begin.

After all installer programming is completed, use the following procedure to exit programming mode.

**To exit programming mode:**

- Press \* until EXIT - DL is displayed and then press #. The current time will be displayed.
- Or
- Press \* until EXIT - DL is displayed and then enter installer or dealer code to start a Downloader session.

**User Programing Menu Items**

This section guides you through the user programing menu items as they appear in sequence.

**Entering User Programming Mode**

There are two tiers of user programming menus. Tier 1 menus are accessible immediately after entering the program mode.

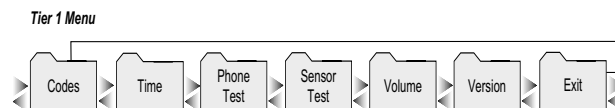

Figure 11. Tier 1 User Programming Menus

Arrows pointing left and right represent the up and down arrows on the panel.

You can enter the user programming mode using the primary access code. The default primary access code is 1234.

**To enter user programming mode:**

With the system disarmed, press [8] + [0][0][0][0]. This will take you to CODES, the first menu item in Tier 1.

**Codes (1st Tier)**

<b>Apartment Manager</b> 2nd Tier	<i>(Codes)</i>
<p>(Default = none, Parameters = 4 digits, 0 to 9) The apartment manager code functions the same as the primary code within the user programming menu, and can arm or disarm the system.</p> <p><b>Note</b> This code will only be displayed in user programming if the apartment manager code was used to enter user program mode.</p> <p><b>To program/change apartment manager code:</b></p> <ol style="list-style-type: none"> <li>1. Enter the apartment manager code. The display shows CODES.</li> <li>2. Press #. The display shows MANAGER.</li> <li>3. Press # to display the current code (if any).</li> <li>4. Press #, enter the desired code and then press #.</li> </ol>	

<b>Primary</b> 2nd Tier	<i>(Codes)</i>
<p>(Default = 1234, Parameters = 4 digits, 0 to 9) The primary code performs all system operations and user programming.</p> <p><b>To set the primary code:</b></p> <ol style="list-style-type: none"> <li>1. Press # to display the current code.</li> <li>2. Press #, enter the desired code and then press #.</li> </ol>	

**User 2, 3, 4** (Codes)  
2nd Tier

(Default = none, Parameters = 4 digits, 0 to 9) User Codes performs arming and disarming functions. The user codes cannot directly bypass sensors or program the primary code. The system allows up to 3 user codes (user 2 - 4).

**To program/change user 2, 3, 4 code:**

1. Press # to display the current user code (if any).
2. Press #, enter the desired user code and then press #.

**Time** (Time)  
1st Tier

(Default = 00:00) This setting lets you adjust the panel's clock to the correct time. The panel uses a 12-hour clock.

**To set the time:**

1. Press # to display the time.
2. Press #, enter the current time, use the arrow key to select am or pm and then press #.

**Phone Test** (Phone Test)  
1st Tier

This setting lets you perform a manual phone test to check the phone communication between the panel and the central monitoring station.

**Note**  
The DTIM and phone number must be programmed before the panel will display the Phone Test option.

**To perform a phone test:**

- Press # to perform a phone test. The panel will indicate if the test was successful or not.

**Sensor Test** (Sensor Test)  
1st Tier

This setting lets you perform a manual sensor test to check that all the sensors are working properly.

- A DTIM and battery test are performed at the start of the sensor test. The panel will display the DTIM zone number and beep once for every received transmission.
- The panel will beep indicating the number of transmissions received, (see Table B4: "Minimum Beeps," on page 18), and display the sensor name + OK to indicate a satisfactory test of the sensor. For the first 10 to 20 seconds of test, the volume is set to a lower level.
- Panel will automatically leave sensor test after 15 minutes.
- The panel will display ALL OK when all sensors have been tested.
- If Low Lvl reports are on, the panel will send a start of test central station report when a sensor test is initiated.
- The panel will send an end of test central station report when the sensor test ends.

**To run a sensor test:**

1. Press # to display the sensor test (TEST; ZONE XX). The display then scrolls thru the untested zones, and beeps indicating the number of sensor packets received.
2. To trip a sensor, follow the instructions in Table 5.
3. To restart the list, press 1. This will also restart the 15 minute timer.

**Table 5: Sensor Tripping Instructions**

Sensor	Do This
DTIM	Initiate a sensor test.
Door/Window	Open the secured door or window
Carbon Monoxide Alarm	Unplug the CO Alarm. Plug it back in, then press the TEST/RESET button until the unit beeps 8 times
Glass Guard	Tap the glass 3 or 4 inches from the sensor
Motion Sensor	Avoid the Motion Sensor field of view for 5 minutes, then enter its view
Rate-of-Rise Heat Detector	Rub your hands together until warm, then place one hand on the detector for 30 seconds
Shock	Tap the glass twice, away from the sensor. Wait at least 30 seconds before testing again
Smoke	Press and hold the test button until the system sounds transmission beeps
Panic Buttons	Press and hold the appropriate panic button(s) for 3 seconds
KeyChain Touchpad	Press and hold LOCK and UNLOCK simultaneously for 3 seconds
Remote Handheld Touchpad	Press and hold the 2 EMERGENCY buttons simultaneously for 3 seconds

<b>Volume 1st Tier</b>	<i>(Volume)</i>
<p>(Default = 0, Parameters = 0-5) This setting allows the user to adjust the panel's status and arming level beep volume. The volume can be set from 0 to 5, with 0 being the lowest volume.</p> <p><b>To set the volume:</b></p> <ol style="list-style-type: none"> <li>1. Press # to display the current volume.</li> <li>2. Press #, enter the desired volume level and then press #.</li> </ol>	

### Exiting User Programming Mode

After all user programming is completed, use the following procedure to exit programming mode.

**To exit programming mode:**

- Press \* until EXIT is displayed and then press #. The current time will be displayed.

### Downloader Programming

The panel can be programmed remotely using ToolBox. Allegro has a 100 event buffer that can only be viewed by ToolBox. Use the information you recorded in Appendix B to inform the downloading operator of the programming requirements for this system.

### ToolBox Downloader Programming

**Note**

A Downloader Phone Number and DL Code must be programmed for remote downloader programming to work.

**To initiate a ToolBox download session:**

1. Contact your downloader station and ask the operator to prepare to download to the panel.
2. Make sure the system is disarmed.
3. Go into installer program mode.
4. Press \* to go to the EXIT - DL display.
5. Enter the installer or dealer code.
6. When the downloader session completes, a panel programmed status message will be displayed.

If the panel display does not flash DOWNLOADING, call the downloader operator to verify the downloader phone number. Also, make sure ToolBox is set up properly. Refer to the "Troubleshooting" section (on page 19) if the problem persists.

**To initiate a ToolBox download session using the Ring/Hang/Ring method:**

For off-site access where an answering machine does not exist, the user or ToolBox operator simply calls the panel location once and listens for 10 rings. The panel should answer after the tenth ring.

For off-site access where an answering machine exists, the user or ToolBox operator must perform the following steps:

1. Call the panel location.
2. Let the phone ring once, then hang up.

3. Wait at least 10 seconds but not more than 40, then call the panel location again. The panel should answer on the first ring.

## Testing the System

You should test the system after installing, servicing, and after adding or removing devices from the system (see Testing Sensors/Zones on page 18).

**Note**



















UL Listed systems must be tested weekly.

Refer to "Appendix A: Troubleshooting" (on page 19) if correct test results are not achieved.



## Basic System Commands

Table 6 describes the system's basic panel keypad operating commands. For complete details on system operation, including user programming, refer to the system's owner's manual.

**Table 6: Basic Operating Commands**

How to...	Command
Check system status.	 Press once
Clears current display.	 + 
Arms doors and windows.	 + Code
Arms doors and windows, no delay.	 + Code +  4
Arms motions, doors, and windows.	 (twice) + Code
Arms motions, doors, and windows, no delay.	 (twice) + Code +  4
Arms doors and windows.	 Press once if quick arm in on
Arms motions, doors, and windows.	 Press twice if quick arm in on
Arms system silently (no arming status beeps, until the last 10 seconds of delay). Key press beeps still sound.	 +  + Code
Turns chime feature on and off.	 7 Press once
Identifies alarms in memory.	 Press once
Bypass	 # + Primary Code
Unlock	 + Code
Quick Exit	 Press once, starts a 2 minute timer

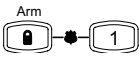
**Table 6: Basic Operating Commands (Continued)**

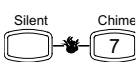
How to...	Command
Police Panic	 Press and hold both buttons until panel indicates alarm.
Emergency Panic	 Press and hold both buttons until panel indicates alarm.
Fire Panic	 Press and hold both buttons until panel indicates alarm.

**Testing Sensors/Zones**

We recommend that you test sensors/zones after all programming is completed and whenever a sensor/zone-related problem occurs.

If the system does not respond as described in Sensor Test (on page 18), see “Appendix A: Troubleshooting on page 19.”

**Note**

While the sensor test is a valuable installation and service tool, it only tests sensor operation for the current conditions. You should perform a sensor test after any change in environment, equipment, or programming.

**To test sensors:**

1. Go into sensor test; trip sensor.
2. Count the number of beeps that the panel emits.

Refer to Table 7 for the preferred number of beeps required.

**Table 7: Minimum Beeps**

Type of Sensor	Number of Beeps
Wireless Intrusion Sensors	7-8 beeps
Wireless Smoke & Heat Sensors	7-8 beeps

**Table 7: Minimum Beeps**

Type of Sensor	Number of Beeps
Wireless Environmental/Panic Buttons	7-8 beeps
Hardwire Loops	1
Emergency Buttons (Remote Handheld Touchpads only)	7-8 beeps
Keychain Touchpad	3 beeps
DTIM's	7-8 beeps

**If a Wireless Sensor Does Not Test**

When possible, locate wireless sensors within 100 feet of the panel. While a transmitter may have a range of 500 feet or more out in the open, the environment at the installation site can have a significant effect on transmitter range. Refer to “Appendix A: Troubleshooting” (on page 19) to resolve the problem.

For wireless sensors that don't respond, use an ITI RF Sniffer (60-401) test tool to verify that the sensor is transmitting. Constant beeps from the RF Sniffer indicate a runaway (faulty) sensor. Remove the sensor's battery and replace the sensor.

**Testing Phone Communication**

Perform a phone test to check the phone communication between the panel and the central monitoring station, see Phone Test (Reports) on page 14.

**Testing Central Station Communication**

After performing sensor and phone tests, check that the system is reporting alarms successfully to the central station.

**To test communication with the central station:**

1. *To avoid the dispatch of emergency personnel, call the central station and tell the operator that you will be testing the system!*
2. Arm the system.

## Appendix A: Troubleshooting

Feature	Problem	Action/Solution
<b>Panel Power</b>		
	Panel does not power up and does not display or respond.	<ol style="list-style-type: none"> <li>1. Check that panel transformer is plugged into an unswitched outlet.</li> <li>2. Check the AC circuit breaker to be sure the circuit is live.</li> <li>3. Check that the backup battery is installed correctly and the AC power transformer is plugged in.</li> <li>4. Check for proper panel and transformer wiring.</li> <li>5. Measure the incoming AC voltage at panel terminals 1 and 2. It should read about 8 VAC.</li> </ol>
	No incoming AC voltage at panel terminals 1 and 2.	<ol style="list-style-type: none"> <li>1. Unplug the AC power transformer and disconnect the wires from the transformer and the panel.</li> <li>2. Check transformer to panel wire for short or open circuits.</li> <li>3. Plug in the transformer and check for 8.0 VAC at the transformer unconnected terminals. If zero (0) volts, replace the transformer. If transformer is good, call Tech Support.</li> </ol>
	Panel display indicates <i>Low CPU Battery</i> .	<p><b>Note</b> If the AC power was out for an extended period of time, the battery may not be fully charged yet.</p> <ol style="list-style-type: none"> <li>1. Perform a battery test by entering and exiting sensor test.</li> <li>2. Check that the backup battery is installed correctly and the AC power transformer is plugged in.</li> <li>3. Measure the incoming AC voltage at the panel terminals 1 and 2. It should read about 8 VAC.</li> <li>4. Remove the backup battery power by disconnecting the battery and replace the battery.</li> </ol> <p><b>Note</b> If AC power is present, the battery voltage is only monitored during a backup battery test. The panel automatically runs a backup battery test under the following conditions: (1) during user sensor test, (2) once every 4 hours, (3) when the back cover is closed. In order for the panel to update the battery status, a backup battery test must be run.</p> <p><b>Note</b> With the AC power transformer plugged in, the panel automatically charges the battery. While the battery is charging for the first time it is normal for the system to indicate <i>Low CPU Battery</i>. Charging the battery can take a number of hours depending on the battery's initial charge. Once the battery reaches 4.8 VDC (full charge as measured while in battery test), the condition clears. If the trouble condition persists after 24 hours, replace the backup battery. A Low Battery report to the central station will not be made for the first 24 hours after power up.</p>
	After pressing <b>STATUS</b> the panel flashes <i>AC Fail</i> , (panel continues to operate from backup battery).	<ol style="list-style-type: none"> <li>1. Check the AC circuit breaker to be sure the circuit is live.</li> <li>2. Check for proper panel and transformer wiring.</li> <li>3. Check that the transformer is supplying AC to the panel.</li> <li>4. Check that the transformer is plugged into a nonswitched outlet and secured with the provided screw.</li> </ol> <p><b>⚠ WARNING</b> <b>Be careful when securing the transformer to an outlet with a metal cover. Hold the cover tightly in place. You could receive a serious shock if the metal outlet cover drops down onto the prongs of the plug while you are securing the transformer and cover to the outlet box.</b></p>
<b>Access Code</b>		
	Customer cannot remember access code(s).	<ol style="list-style-type: none"> <li>1. Check your records to see if you have the customer's access code(s) on file.</li> <li>2. Verify the access code(s) using the Downloader.</li> <li>3. Clear memory and reprogram the panel locally.</li> <li>4. Use Apartment Manager code to enter program mode and view the primary and user codes.</li> </ol>
	Installer cannot remember install code.	<ol style="list-style-type: none"> <li>1. Check your records to see if you have the install code on file.</li> <li>2. Verify the install code using the Downloader.</li> <li>3. Use the Dealer Code to enter program mode and view the installer code.</li> <li>4. Call Technical Support for assistance.</li> </ol>
<b>Arming/Disarming</b>		

Feature	Problem	Action/Solution
	System protests and will not arm immediately.	<ol style="list-style-type: none"> <li>1. Press <b>STATUS</b> for an indication of the problem.</li> <li>2. Make sure all monitored perimeter doors and windows are closed.</li> <li>3. Make sure all perimeter and interior sensors are closed.</li> </ol>
<b>Bypassing</b>		
	Sensor to bypass is not listed.	<ol style="list-style-type: none"> <li>1. Attempting to bypass a 24-hour sensor (a sensor that is active in all levels) that cannot be bypassed.</li> <li>2. Sensor is not active in the current arming level.</li> <li>3. Sensor is not learned in.</li> </ol>
<b>Wireless Sensor/Touchpad Battery</b>		
	System indicates <i>Sensor/Touchpad low battery</i> .	<p>Replace the indicated device battery. Perform a sensor test to test the sensor/touchpad after replacing the battery.</p> <p><b>Note</b> If the sensor/touchpad is not tested after battery replacement, the system continues to show a low battery condition, since that was the last signal it received from the device. Testing the sensor/touchpad with new batteries allows the panel to receive a signal with good battery information.</p>
<b>Central Station Reporting</b>		
	Central station is not receiving reports.	<ol style="list-style-type: none"> <li>1. Check that the premises phone line is working.</li> <li>2. Perform a phone test.</li> <li>3. Check for correct phone line wiring between the DTIM and RJ-31X Jack (see DTIM Installation Instructions).</li> <li>4. Verify that central station phone number is programmed into the panel. If necessary, reprogram the phone number and retest.</li> <li>5. Verify that the correct phone format (SIA or CID) is being used.</li> </ol>
<b>Hardwire Zone</b>		
	System doesn't go into alarm when zone is tripped.	<ol style="list-style-type: none"> <li>1. Sensor is not active in current arming level. Verify sensor group and retest.</li> <li>2. Zone is not learned into panel memory. Enter installer program mode. Go to Devices, then Add and learn zone into memory.</li> <li>3. Verify wiring.</li> </ol>
<b>Wireless Sensor Zone</b>		
	System doesn't respond (in sensor test or when armed) when sensor is tripped.	<ol style="list-style-type: none"> <li>1. Check that the wireless sensor battery is installed.</li> <li>2. Check the sensor battery for low voltage. Replace batteries, if necessary.</li> <li>3. Use an RF Sniffer (60-401) to verify that sensor is transmitting.</li> <li>4. Constant beeps from the RF Sniffer indicate a runaway (faulty) sensor. Remove the sensor's battery and replace the sensor.</li> <li>5. Sensor is not learned into panel memory. Enter installer program mode—Devices, Add, and learn sensor into memory (maximum zones = 20).</li> <li>6. Sensor may be out of range. Move sensor to another location.</li> </ol>
	Sensor reports trouble condition.	<ol style="list-style-type: none"> <li>1. Sensor tamper switch is tripped—sensor cover is off, not latched securely, or sensor is not mounted securely. Secure sensor mounting and/or cover, then trip sensor to clear the condition.</li> <li>2. Check the sensor battery for low voltage. Replace batteries, if necessary.</li> </ol>

Feature	Problem	Action/Solution
<b>Wireless Sensor Zone (Continued)</b>		
	Panel indicates <i>[sensor #] supervisory</i> .	<ol style="list-style-type: none"> <li>1. Use an RF Sniffer (60-401) to verify that sensor is transmitting. If sensor is not transmitting, check battery for low or no voltage and replace.</li> <li>2. Change mounting position of sensor (from horizontal to vertical or vice versa) and test sensor several times for consistency.</li> <li>3. Sensor signal is not reaching panel/receiver because sensor is too far away or there is too much interference. Remove sensor from mounted location and test from other locations. Mount sensor in area where signal can reach panel/receiver.</li> </ol>
	Smoke sensor beeps once every minute.	<p>Sensor batteries are getting low. Replace batteries.</p> <p><b>Note</b> System Sensor smoke sensors do not transmit a low battery signal to the panel/receiver until battery voltage drops to within a range of 7.0 to 7.8 VDC. The sensor sounds beeps to notify occupants that the sensor's batteries need replacing, but the sensor does not transmit a low battery signal to the panel until the next supervisory signal (69 minutes later).</p>
<b>Wireless Touchpad</b>		
	System doesn't respond to commands entered from wireless touchpad.	<ul style="list-style-type: none"> <li><input type="checkbox"/> Check for dead batteries.</li> <li><input type="checkbox"/> Perform a sensor test.</li> </ul>
	Touchpad reports trouble condition.	Check the touchpad battery for low voltage. Replace battery, if necessary.
<b>DTIM</b>		
	Panel displays <i>phone module memory failure, or Service required</i> .	<ol style="list-style-type: none"> <li>1. Perform a sensor test.</li> <li>2. Call technical support for assistance.</li> </ol>
	Panel displays <i>Phone Module Low Battery</i> .	<ol style="list-style-type: none"> <li>1. Replace the battery and perform a sensor test.</li> <li>2. Call technical support.</li> </ol>
<b>Phone</b>		
	Constant dial tone, preventing dial-out on premises phones.	One or more polarity-sensitive phones exist on-site.
	Panel displays <i>phone 1 fail, phone 2 fail, or phone failure</i> .	<ol style="list-style-type: none"> <li>1. Perform a phone test.</li> <li>2. Check to make sure manual phone test option is on.</li> <li>3. Verify that high and/or low level reporting option is on.</li> <li>4. Perform a sensor test to verify communication between the DTIM and panel. See Phone Test (Reports) on page 14</li> <li>5. Check DTIM wiring (see DTIM installation instructions).</li> </ol>
<b>Phone Test</b>		
	Panel does not display option to perform a phone test.	<ul style="list-style-type: none"> <li><input type="checkbox"/> The central station phone number is not programmed in.</li> <li><input type="checkbox"/> DTIM has not been enrolled.</li> </ul>
<b>Downloader</b>		
	Download/upload session fails on a pre-programmed panel.	<ol style="list-style-type: none"> <li>1. Verify Downloader Phone Number matches ToolBox setting.</li> <li>2. Verify Downloader CODE matches ToolBox setting.</li> <li>3. Verify Dealer CODE matches ToolBox setting.</li> <li>4. Verify panel Account Number matches ToolBox setting.</li> </ol>

## Preliminary 2/5/02

Feature	Problem	Action/Solution
	Download/upload session fails on an unprogrammed panel.	<ol style="list-style-type: none"><li>1. Verify Downloader Phone Number matches ToolBox setting.</li><li>2. Verify Downloader CODE matches ToolBox setting.</li><li>3. Verify Dealer CODE matches ToolBox setting.</li></ol>



## Appendix B: Reference Tables

**Table B1: Sensor Group Characteristics**

No.	Name	Application	Alarm	Delay	Restoral	Supervisory	CS Report	Chime	Active Levels
00	Fixed Panic	24-hour audible fixed emergency buttons.	Police	Instant		√	√		1, 2, 3
01	Portable Panic	24-hour audible portable emergency buttons.	Police	Instant			√		1, 2, 3
02	Fixed Panic	24-hour silent fixed emergency buttons.	Silent	Instant		√	√		1, 2, 3
03	Portable Panic	24-hour silent portable emergency buttons.	Silent	Instant			√		1, 2, 3
04	Fixed Emergency	24-hour emergency sensor, such as Pendant Panic or holdup button.	Emergency	Instant		√	√		1, 2, 3
06	Portable Emergency	24-hour portable emergency alert button.	Emergency	Instant			√		1, 2, 3
08	Special Intrusion	Special belongings, such as gun cabinets and wall safes.	Police	Instant	√	√	√		1, 2, 3
09	Special Intrusion	Special belongings, such as gun cabinets and wall safes.	Police	Standard	√	√	√		1, 2, 3
10	Entry/Exit Delay	Entry and exit doors that require a standard delay time.	Police	Standard	√	√	√	√	2, 3
13	Instant Perimeter	Exterior doors and windows.	Police	Instant	√	√	√		2, 3
14	Instant Interior	Interior doors.	Police	Follower	√	√	√		2, 3
15	Instant Interior	Interior PIR motion sensors. *	Police	Follower		√	√		2, 3
16	Instant Interior	Interior doors.	Police	Follower	√	√	√		3
17	Instant Interior	PIR motion sensors. *	Police	Follower		√	√		3
18	Instant Interior	PIR motion sensors subject to false alarms. * †	Police	Follower		√	√		3
19	Delayed Interior	Interior doors that initiate a delay before going into alarm. *	Police	Standard	√	√	√		3
20	Delayed Interior	PIR motion sensors that initiate a delay before going into alarm. *	Police	Standard		√	√		3
21	Local Instant Interior	24-hour local alarm zone protecting anything that opens and closes.	Police	Instant	√	√			1, 2, 3
22	Local Delayed Interior	Same as group 21, plus activation initiates a delay before going into alarm.	Police	Standard	√	√			1, 2, 3
23	Local Instant Emergency	24-hour local alarm zone protecting anything that opens and closes. ‡	Emergency	Instant	√	√			1, 2, 3
25	Local Special Chime	Notify the user when a door is opened. Sounds emit from a local annunciator. *  <b>Note</b> If using a PIR motion sensor, use only ITI part no. 60-511-01-95.	Special Chime	Instant		√			1, 2, 3
26	Fire	24-hour fire, rate-of-rise heat, and smoke sensors.	Fire	Instant	√	√	√		1, 2, 3
34	Gas	Carbonmonoxide (CO) Gas Detectors ‡	Emergency	Instant	√	√	√		1, 2, 3
36	DTIM	Dialog Telephone Interface Module (DTIM) ⌘	Police	Instant		√	√		1, 2, 3

**Table B1: Sensor Group Characteristics (Continued)**

No.	Name	Application	Alarm	Delay	Restoral	Supervisory	CS Report	Chime	Active Levels
<p><b>Note</b>                      Check marks (√) represent characteristics present in a group.</p> <p>* This group is not certified as a primary protection circuit for UL-listed systems and is for supplementary use only.</p> <p>† Sounds instant police siren if two or more sensors are tripped within 4 minutes. Otherwise sensors are followers to delayed sensors. If Alarm Verification is on, group 18 functions like group 17.</p> <p>‡ This group has not been investigated by UL.</p> <p>⌘ The DTIM will report in all levels.</p> <p><b>Siren Type:</b></p> <p>Police - A sensor of this type will output a police siren when an alarm occurs. The panel's LCD will display a message indicating to the end user a police alarm has occurred.</p> <p>Fire - A sensor of this type will output a fire siren when an alarm occurs.</p> <p>Silent -If an alarm of this type occurs, the siren will not sound and there will be no visual indication.</p> <p>Emergency -</p> <p><b>Delay:</b></p> <p>Instant -A sensor of this type will cause an immediate alarm if a violation occurs anytime in an active arming level.</p> <p>Standard - A sensor of this type will cause an entry delay if a violation occurs anytime in active arming level. A violation during an exit delay will not cause an alarm.</p> <p>If the arming level modifier No Delay is enabled a sensor of this type will cause an immediate alarm if the violation occurs during an active arming level.</p> <p>Follower - A sensor of this type will cause an immediate alarm if a violation occurs during an active level unless an entry or exit delay is in progress. If violated during an entry delay and the entry delay expires the sensor will go into alarm.</p>									

**Table B2: System Settings**

Menu Name & Default	Parameters	Settings
Account (00-000)	4-10 digits; 0-9, A-F	
Number 1 (none)	24 digits; 0-9, *, #, pause	
FMT - CID/SIA (CID)	1=CID, 0=SIA	
High LVL (on)	off, on	
Low LVL (on)	off, on	
Openings (off)	off, on	
Closings (off)	off, on	
Number 2 (none)	24 digits; 0-9, *, #, pause	
FMT - (CID)	1=CID, 0=SIA	
High LVL (off)	off, on	
Low LVL (off)	off, on	
Openings (off)	off, on	
Closings (off)	off, on	
Backup (on)	off, on	
Dial DLY (30)	15-120	
Pre-dial String (none)	8 digits; 0-9, *, #, pause	
DTMF Dial (on)	off, on	
Number (none)	24 digits; 0-9, *, #, pause	

**Table B2: System Settings (Continued)**

Menu Name & Default	Parameters	Settings
DL Code (12345)	5 digit code, 0-9	
Install Code, 4321	4 digit code, 0-9	
Dealer Code, none	4 digit code, 0-9	
Duress Code, none	4 digit code, 0-9	
Apartment Manager Code, none	4 digit code, 0-9	
Entry DLY, 30	30-240	
Exit DLY, 60 (60 for UL1023)	45-254	
PH TST Freq, 7	1-255	
NXT PH Test, 7	1-255	
Sleepy Time, on (off for UL installations)	off, on	
Sleep Hour, 22	0-23	
KTP Arm, off	off (ratchet arm), on (all on), No Delay	
Police Panic, on	off, on	
Emergency Panic, off	off, on	
Fire Panic, on	off, on	
Rcvr Trouble, off (on for UL installations)	off, on	
Panel Tamper, on	off, on	
Exit EXT, on (off for UL installations)	off, on	
Swinger Shutdown, 1	1-2	
Quick Arm, off	off, on	
Quick Exit, on (off for UL installations)	off, on	
Auto Stay Arm, on	off, on	
Supv Time, random	1 am - 5 am	
Alarm Verify, off (off for UL installations)	off, on	
Demo Kit, off	off, on	
AC Fail, off (on for UL 1635)	off, on	
Low CPU Battery, on (on for UL 1635)	off, on	
Phone Test, on	off, on	
Auto Phone Test, off (on for UL 1635)	off, on	
Siren Time Out, 4 (min for UL installations)	1-30	
Trouble Beeps, on (on for UL installations)	off, on	
Alarm Volume, 6 (min for UL installations)	0-6	

**Table B3: Sensor Information**

Sensor Number	Sensor Text	Sensor Type	Sensor Group
01			
02			
03			
04			
05			
06			
07			
08			
09			
10			
13			
14			
15			
16			
17			
18			
19			
20			

**Table B4: Central Station Reports**

Report Condition	Report Types		
	High-Level Events	Low-Level Events	Opening/Closing
Sensor 01-MaxZones Alarm	√		
Sensor 01-MaxZones Low Batter		√	
Sensor 01-MaxZones Tamper	√		
Sensor 01-MaxZones Supervisory		√	
Phone Test	√	√	
AC Power Fail		√	
CPU Low Battery		√	
Auto Phone Test	√	√	
Receiver Failure (or Receiver Trouble?)	√		
Receiver Jam	√		
Event Buffer Full		√	
System Tamper	√		
Fire Panic	√		
Police Panic	√		
Auxiliary Panic	√		
Opening report			√
Closing Report			√
Duress Alarm	√		
Force Arm		√	
Recent Closing	√		
Sensor Test Entry/Exit		√	

# Appendix C: Installation Menus

## TIER 1 MENUS

To enter Programming Mode: 8 + Installer or 8 + Dealer Code



## TIER 2 MENUS

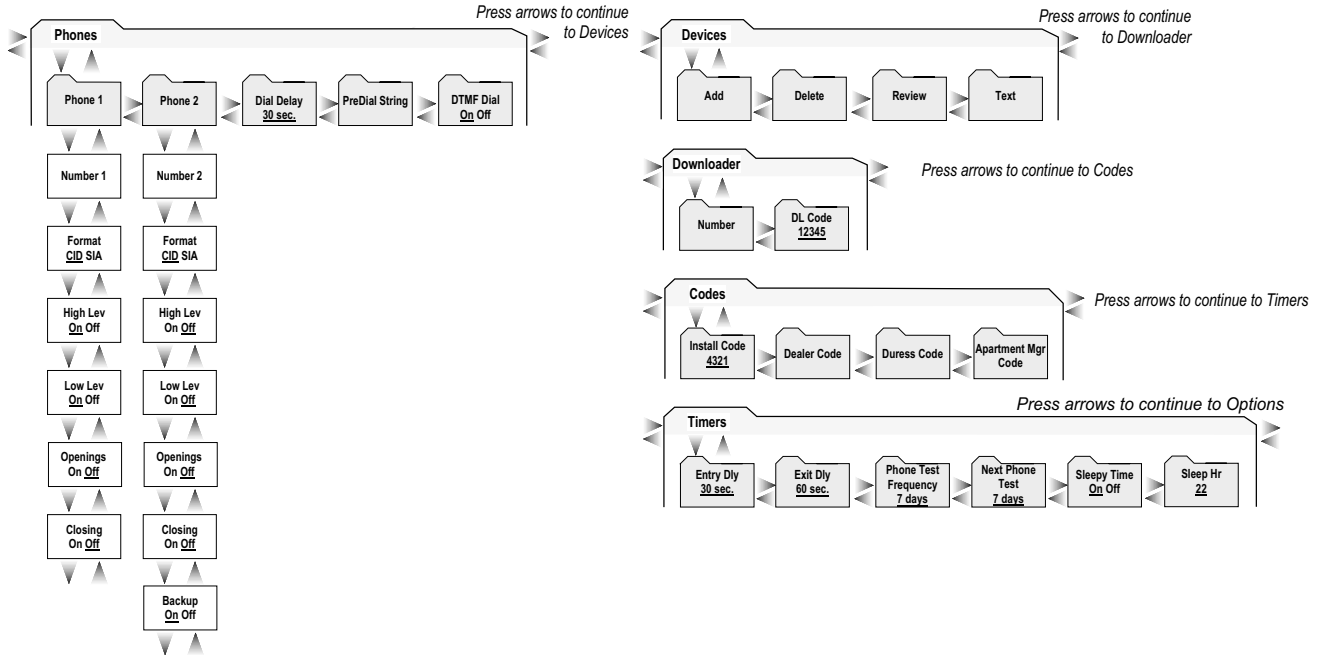

## TIER 2 MENUS (continued)

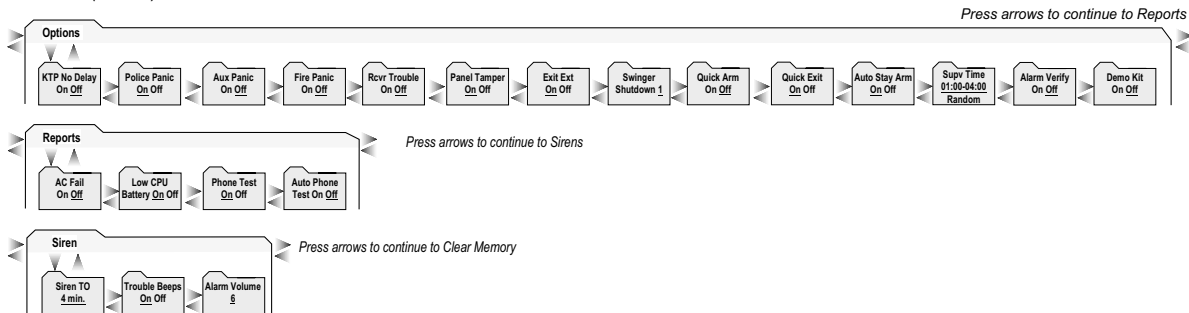

**Note:**  
Underlined settings indicate defaults

## Specifications

**Power Requirements:** .....8 VAC, 300 mA

**Rechargeable Battery:**.....4.8 VDC Rechargeable NiCd Battery pack

**Radio Frequency:** .....319.5 MHz + or - 140 kHz

**Nominal Range:** ..... 500 feet, open-air receiving range

### Temperature Range

Storage:.....-30° to 140° F (-34° to 60° C)

Operating: ..... 32° to 122° F (0° to 49° C)

**Maximum Humidity:** ..... 90% relative humidity, noncondensing