

# PrecisionLine™ RCR-50

## Dual Technology Motion Sensor

### Installation Instructions



## Description

The RCR detector combines range-controlled radar (RCR) technology with a passive infrared (PIR) system to increase false alarm immunity by allowing it to sense human-sized objects within a specified range. Both the RCR and PIR systems must be triggered to set off an alarm, unless in radar-only mode.

The detector is designed to use a 12VDC power supply provided by a UL Listed alarm control panel.

## Features

The detector provides the following features:

- **High-security (radar-only) mode** - Internal jumper allows you to disable the PIR, and use the radar-only mode to detect intruders faster. This mode can be used for covert installations (mounted behind ceiling panels or walls).
- **Selectable range up to 50 feet (15.2m)** - Internal jumper allows radar range selection to optimize coverage.
- **LED indicator** - A multi-color LED provides detector status.
- **Tamper switch** - Activated when the pins on the circuit board are removed from the terminal sockets on the base.

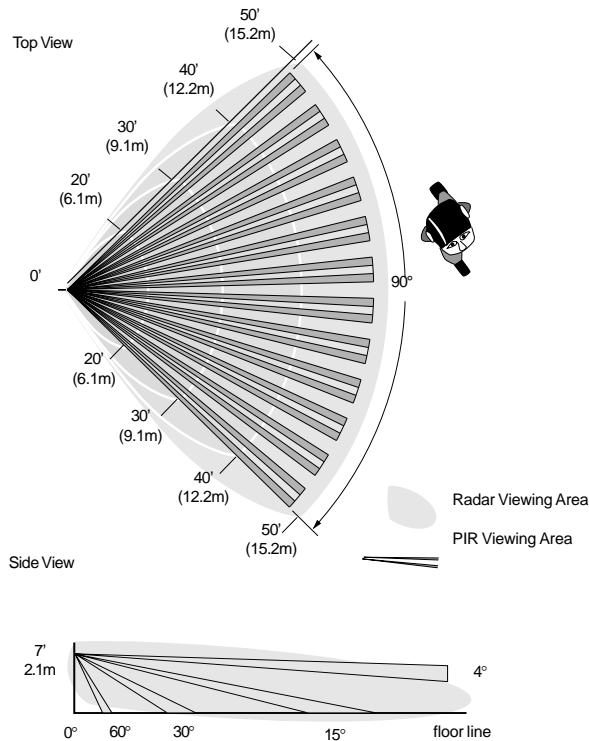

Figure 1. Coverage Patterns

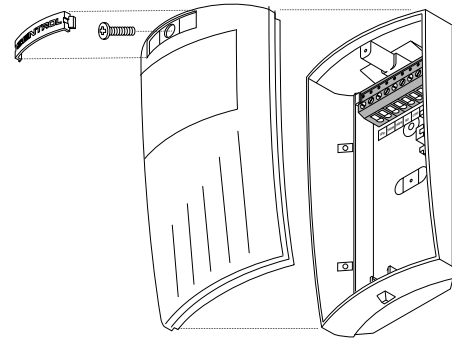

Figure 2. Detector (Exploded)

## Parts

The following parts are included:

- RCR detector
- 1 screw to join the case halves
- 3 factory-installed jumpers

## Selecting a Location for the Detector

The detector can be mounted in a corner or on a flat wall. Use the following guidelines to determine the best location to install the detector:

- Mount the detector so the expected movement of an intruder is across the detection pattern. See Figure 1.
- Mount the detector on a stable surface 7 to 9 feet (2.1 to 2.7m) high.
- DO NOT mount the detector within 2 feet (0.6m) of metallic objects or within 5 feet (1.5m) of florescent lights.
- DO NOT place objects in front of the detector that may prevent a clear line of sight. (Not applicable in radar-only mode.)
- Avoid locations that expose the detector to possible false alarm sources such as:
  - Moving or vibrating objects (fans, pulleys, conveyor belts)
  - Electronic fields (electric motors, high voltage equipment)
  - Water spray or corrosive environments
  - Heat sources in the field of view (heaters, radiators)
  - Windows in the field of view
  - Strong air drafts on the detector (fans, air conditioners)
- When installing multiple detectors:
  - DO NOT mount detectors facing each other.
  - Mount detectors at least 20 feet (6.1m) apart.
  - Use shorter range settings to avoid overlapping radar coverage.
  - Mounting detectors back to back is not recommended, but if an application requires such mounting, use the 20-foot (6.1m) range and walk test the installation to ensure proper operation.

## Installing the Detector

All wiring must conform to the National Electric Code (NEC) and/or local codes having jurisdiction.

**Important: DO NOT use this device for safety interlock applications.**

To install the detector:

1. Run the security system wiring to the detector location.
2. To remove the front cover/electronic module, remove the nameplate and loosen the screw if necessary. To remove the nameplate, insert a small screwdriver into one of the nameplate side slots and gently push in and pry up with the screwdriver. See Figure 2. Then press down on the top of the front cover with one hand, while holding the sides at the top of the back cover and squeezing in and pulling back with the other hand.



### CAUTION

**You must be free of all static electricity before handling sensor circuit boards. Touch a grounded, bare metal surface before touching circuit boards or wear a grounding strap.**

3. If necessary, set the jumpers on the circuit board. See *Setting the Jumpers*.
4. Remove the appropriate wiring and mounting knockouts from the back cover. The detector can be mounted on a flat wall or in a corner. See Figure 3.
5. Pull the wires through the knockout holes and use screws to attach the base to the wall. Use screw anchors if necessary.
6. Strip 1/4 inch (6.4mm) of insulation from each wire.
7. Run each wire through the strain relief and under the appropriate screw terminals on the base and tighten the screws. See Figure 3.
8. Line up the tabs on the bottom of the cover/electronic module with the corresponding tabs on bottom of the base and snap the cover/electronic module firmly down onto the base.
9. Tighten the screw and replace the nameplate. See Figure 2.
10. Apply power. The green LED should light for approximately 25 seconds and then go out.
11. Walk test the coverage pattern as follows:
  - Walk throughout the intended coverage area.
  - Verify the detector alarms. See *Understanding the LED*.

### Note

Most units walk test more accurately if the person testing waits 10 seconds between tripping the unit and walking again. This allows the detector to stabilize between trips.

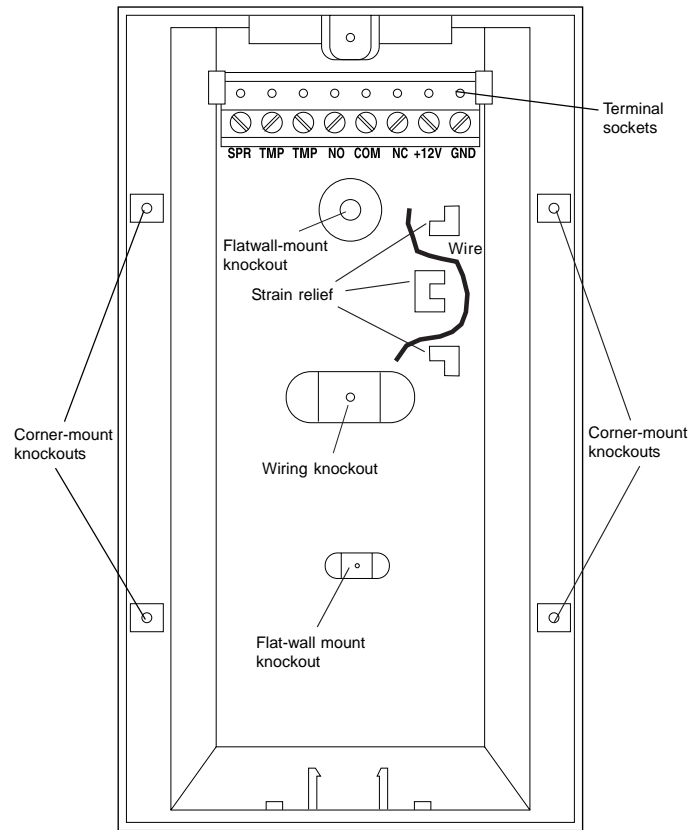

Figure 3. Detector Base

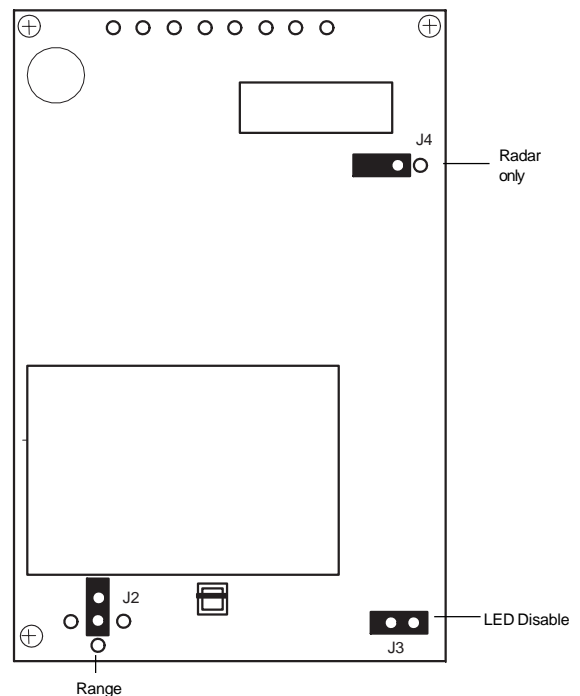

Figure 4. Main Circuit Board

## Setting the Jumpers

The detector provides jumpers to select the detection range and PIR and LED operation. See Figure 4.

**J2 Range** - Use the jumper to cover the center pin and the pin indicating the desired range. No jumper = 50 feet (15.2m) and under.

50 feet (15.2m) and under (factory default)      40 feet (12.2m) and under

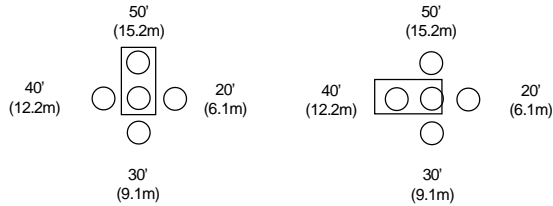

30 feet (9.1m) and under      20 feet (6.1m) and under

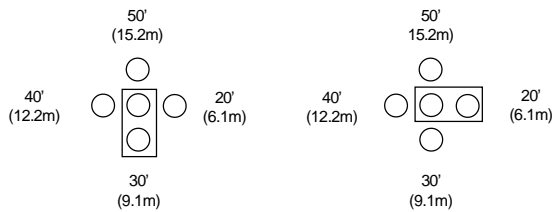

### Note

**You need to set J2 as close to the intended coverage range as possible. Overshooting the coverage area may cause false alarms.**

### J3 LED -

ON = LED enabled (factory default)

OFF = LED disabled

### J4 PIR -

ON = Radar only enabled

OFF = PIR and Radar enabled (factory default)

## SB01 Swivel-Mount Bracket

For ceiling-mount applications that require 90 degree coverage, an optional swivel-mount bracket (SB01) is available from GE Security. See Figure 5.

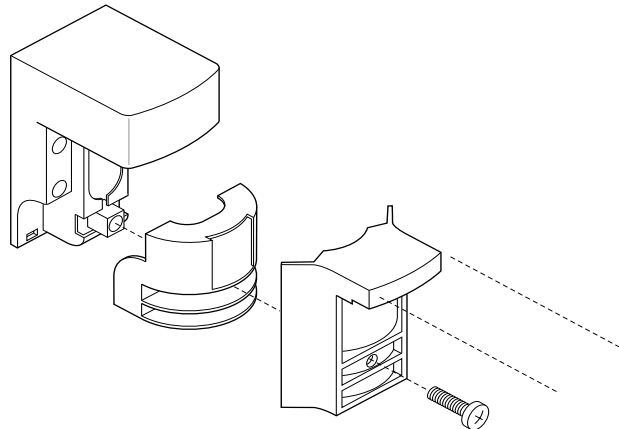

Figure 5. SBO1 Swivel-Mount Bracket

## Maintaining the Detector

When installed and used properly, the detector provides many years of service with minimal maintenance. You should walk test the detector annually to ensure proper operation.

Clean the inside of the unit with a soft-bristled brush or compressed air. Clean the outside with a damp (water) cloth as needed to keep it free of dust and dirt. **Always test the unit after cleaning.**

When the cover is removed, power is interrupted to the sensor. Once the cover has been replaced, the green LED will illuminate for 25 seconds while the sensor warms up. After the green LED goes off, wait one minute and walk test the sensor.

## Understanding the LED

The multi-color LED located on the bottom of the detector indicates the status of the unit as described in the following table.

| LED    | Status   |
|--------|--|
| Red in | PIR and Radar detection. The detector is alarm and the relay has switched. |
| Green  | PIR detection only (no alarm).   |
| Yellow | Radar detection only (no alarm).   |

### In Radar-only mode:

| LED | Status           |
|-----|------------------|
| Red | Radar detection. |

## Specifications

|                          |   |
|--------------------------|---|
| Input voltage            | 8.5 to 18VDC (UL: 10 to 16VDC)                    |
| Typical current          | 27mA  |
| Maximum current          | 35mA  |
| Electrical configuration | Form C  |
| Relay rating             | 28VDC, 100mA max.                                 |
| Tamper                   | 100ma, 40VDC                                      |
| Detection range          | 50' (15.2m) x 90°                                 |
| Target velocity          | 0.5 ft/sec to 5 ft/sec                            |
| Alarm duration           | 5 sec ± 10%                                       |
| Mounting height          | 7' to 9' (2.1m to 2.7m)                           |
| Operating temperature    | 32° F to 122° F (0° C to 50° C)                   |
| Relative humidity        | 5 to 93% non-condensing                           |
| Dimensions:              | 2.8" (7.1cm) W<br>5.1" (13cm) H<br>2.3" (5.7cm) D |
| Weight                   | 6 oz (170g)                                       |
| Color                    | white   |
| Field wiring size        | 12-24 AWG   |
| Microwave frequency      | 5.8GHz  |
| Listing                  | C-UL US   |

## FCC Compliance

This device complies with Part 15 of the FCC rules. Operation is subject to the following three conditions:

- (1) This device may not cause harmful interference.
- (2) This device must accept any interference received, including interference that may cause undesired operation.
- (3) Changes or modifications not expressly approved by the party responsible for compliance could void the user's authority to operate the equipment.

**FCC ID:** CGGAA3

## Product Ordering

| Model Number | Description   |
|--------------|---|
| RCR-50       | Range-controlled radar, passive infrared detector with form C relay, stealth mode, tamper contacts, 50 foot (15.2m) maximum range |
| Accessories  |   |
| SB01         | Swivel-mount bracket  |



**GE Security**  
12345 SW Leveton Drive  
Tualatin, OR 97062  
503-692-4052  
USA & Canada: 800-547-2556

**Tech Support**  
800-648-7424  
FaxBack: 800-483-2495  
[www.ge-security.com](http://www.ge-security.com)

1036806 Rev B 04/04