

DD669-U Dual Detector Installation Sheet

EN

1

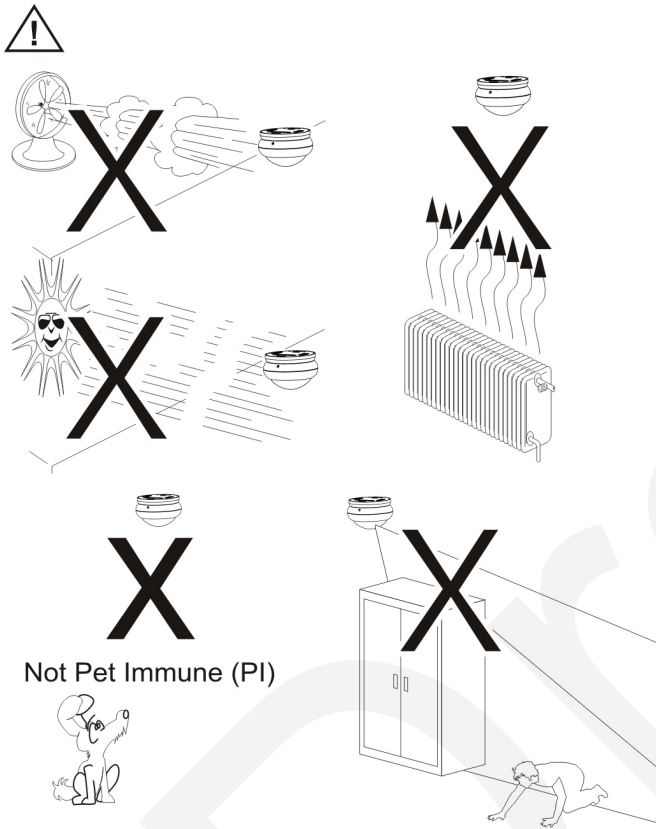

2

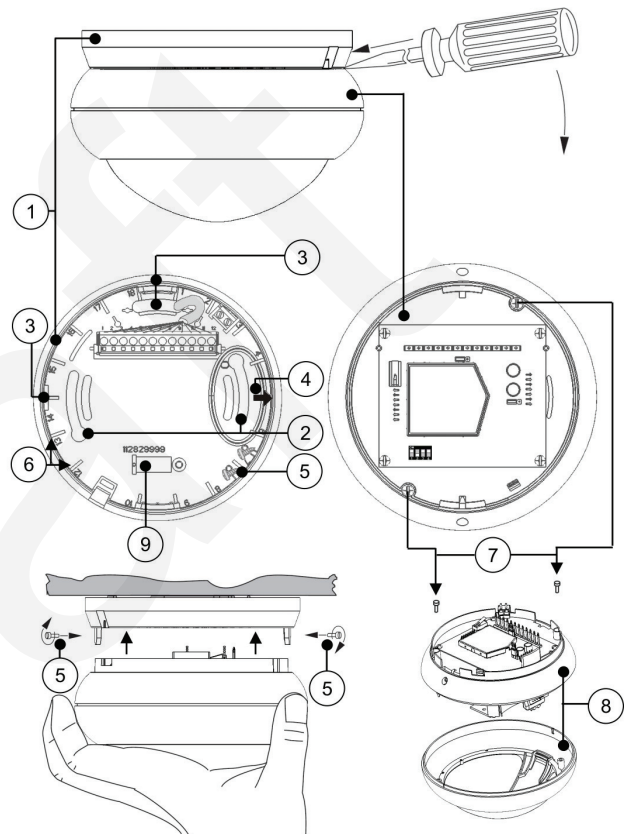

3

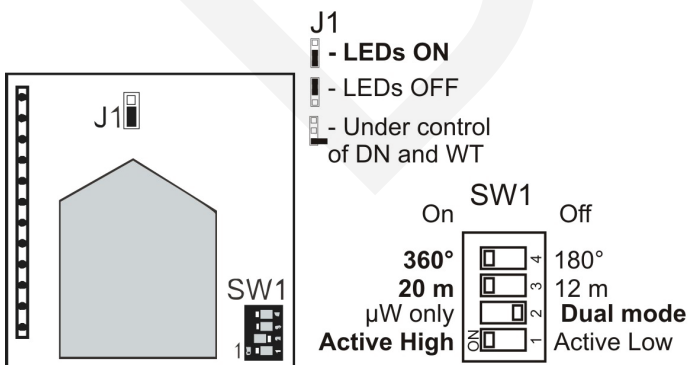

4

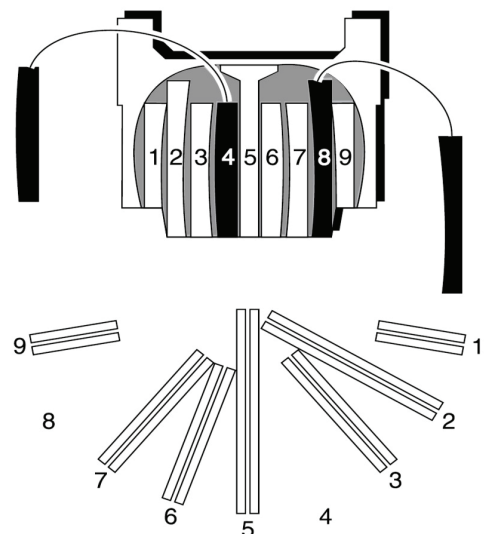

Floor pattern at mounting heights between 2.5 and 3.0 m (8 ft. 2 in. and 9 ft. 10 in.)

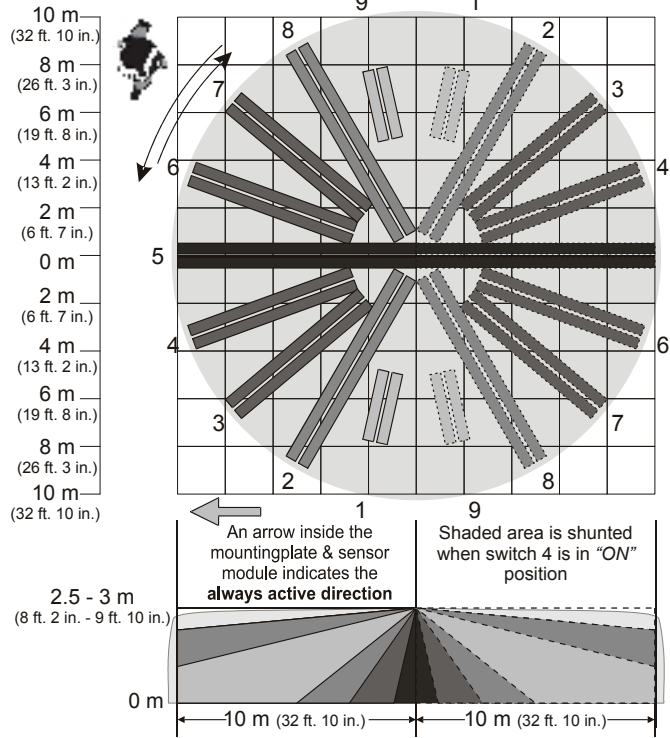

Floor pattern at mounting heights above 3.0 m (9 ft. 10 in.)

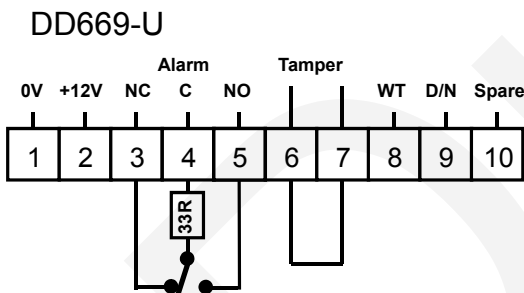
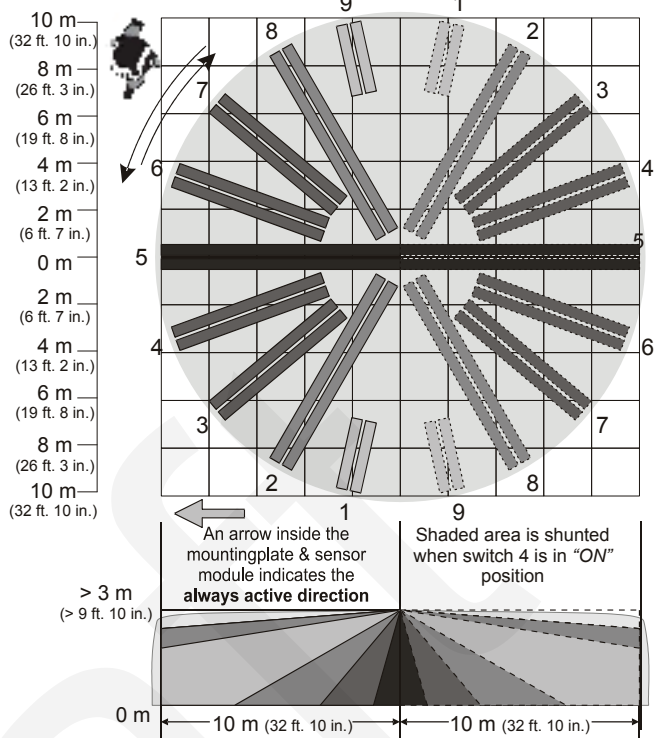

EN: Installation Sheet

Introduction

The DD669-U is a dual motion sensors. It has the patented Range Controlled Radar technology.

Installation guidelines

The detector can be mounted to a ceiling. Use the following guidelines to determine the best location to install the detector:

- Mount the detector so the expected movement of an intruder is across the detection pattern (Figures 5 and 6).
- Mount the detector at a stable surface at a height between 2.5 m (8 ft. 2 in.) and 5.0 m (16 ft. 5 in.).
- Do not mount the detector within 0.5 m (1 ft. 8 in.) of metallic objects or within 1.5 m (4 ft. 11 in.) of fluorescent lights.

- Do not place objects in front of the detector that may prevent a clear line of sight (Figure 1).
- Mount detectors at least 6 m (19 ft. 8 in.) apart, and use the short-range setting to avoid interference.

The dual technology processing of this detector is very resistant to false alarm hazards. However, avoid potential causes of instability, such as:

PIR hazards (Figure 1)

- Direct sunlight on the detector
- Heat sources within the detector field of view
- Strong air draughts onto the detector
- Animals in the field of view
- Obscuring the detector field of view with large objects, such as furniture

Microwave hazards

- Mounting surface susceptible to vibrations
- Metal surfaces reflecting microwave energy
- Water movement through plastic pipes
- Moving or vibrating objects like fans, heating or air-conditioning ducts

We recommend that the detector is regularly walk tested and checked at the control panel.

Installing the detector

1. Lift off mounting plate (see Figure 2, item 1).
2. Fasten the mounting plate to the ceiling in the required position using mounting holes (see Figure 2, item 2). Specified mounting height: min. 2.5 m (8 ft. 2 in.), max. 5.0 m (16 ft. 5 in.). Specified screws: DIN 7996, 4 mm.
3. The detection pattern can be adjusted by up to $\pm 15^\circ$ (max 30°) by rotation of the mounting plate prior to tightening the screws.

- Wire the detector (see Figures 2 and 7).

UL/cUL installations: All wiring must be made according to National Electrical Code, NFPA70, and CSA C22.1, Canadian Electrical Code Part I, Safety Standards for electrical Installations.

Increase of mounting heights beyond the specified 2.5 to 5.0 m (8 ft. 2 in. to 16 ft. 5 in.) will reduce sensitivity. Range varies from 12 to 14 meter (39 ft. 4 in. to 45 ft. 11 in.) in short range and 20 to 22 meter (65 ft. 7 in. to 72 ft. 2 in.) in long range depending on the mounting height.

Note: The arrow (Figure 2, item 4) indicates the centre curtain direction and the active direction when switch 4 is OFF.

- Select the desired jumper and DIP switch settings (see Figure 3). See section "Setting the detector" below for more information.
- To screw the sensor module to the mounting plate, use the screws that are placed for transport in the mounting plate (see Figure 2, item 5).

The curtain directions 1 through 9 clockwise, are indicated on the mounting plate (see Figure 2, item 6). Curtain number 5 is the centre curtain.

Selecting the coverage patterns

For access to the mirror undo screws (Figure 2, item 7) and open the sensor module (Figure 2, item 8). Mask the appropriate mirror curtains with the adhesive labels provided and reassemble the sensor module (see Figure 8 for example).

Setting the detector

See Figure 3 for the jumper locations in the detector.

J1: Setting LEDs

On: Enables both LEDs on the detector at all times (factory default).

Off: Disables both LEDs on the detector at all times.

Removed: Puts both LEDs under the control of the Walk Test and Day/Night input. This activates the memory feature of the detector. When the detector is Disarmed and the input Walk Test is disabled, the microwave section is turned off for DD669-U. In this configuration the detector operates as a PIR only.

SW 1: Polarity setting of the control voltage (CV)

On: Active High. Provides the standard UTC Fire & Security logic with "Active High" logic to enable Walk Test (WT), Day/Night (D/N), and Remote Test inputs (factory default).

Off: Active Low. Provides "Active Low" logic to enable Walk Test (WT), Day/Night (D/N) and Remote Test inputs.

SW 2: μ W only / Dual mode

On: μ W only mode. Consequently the PIR circuitry is switched off and the detector will only signal alarms caused by the microwave circuitry.

Off: Dual mode. In dual mode the detector signals an alarm when both technologies (microwave and PIR) have identified a target moving in the protected area (factory default).

SW 3: Detector range

The microwave can be selected between 20 ± 0.5 m, and 12 ± 0.5 m (65 ft. 7 in. \pm 1 ft. 8 in., and 39 ft. 4 in. \pm 1 ft. 8 in.)

Note: Only the microwave range will be reduced, not the PIR section.

SW 4: Detection coverage

The detection coverage can be selected between 360 degrees for normal application, and 180 degrees for special applications.

Note: Only the coverage of the PIR will be adjusted.

Walk testing the detector

The DD669-U provides a walk test mode for testing the detectors operation and coverage pattern if the detector is set to LED's disabled. To walk test the detector, remove the supply voltage and apply it back on. The walk test mode can be started once the startup sequence has completely finished (LED flashes for 45 seconds). The unit stays in walk test mode for 30 minutes. The detector returns to normal operating mode after the walk test mode times out.

Green mode

The detector can be programmed in several ways to minimize the exposure of microwave radiation to human and animal, although the detector is already sending microwave signal on a very low power level.

The detector will switch the microwave section off for 3 minutes after a dual alarm. The detector is in PIR only during this timer.

| | | |
|-------------------|--------------------------|------------------------|
| Settings option 1 | J1: Off SW 2: Off | |
| Settings option 2 | J1: Removed SW 2: Off | System in Armed status |

The microwave section is switched off and the detector operates in PIR mode only.

| | | |
|---------|--------------------------|--|
| Setting | J1: Removed SW 2: Off | System in Disarmed status System Walk Test Disabled |
|---------|--------------------------|--|

LED indication

| | Red [1] | Green [1] | Yellow [1] | Alarm relay | To reset |
|------------------------------|---------|-----------|------------|--------------|--------------------------|
| Start up | | | | Closed | Automatically after 45 s |
| Low voltage | | | | Open (Alarm) | Apply correct voltage |
| PIR intruder alarm | | | | | Automatically after 3 s |
| Microwave intruder alarm | | | | | Automatically after 3 s |
| (Dual) motion intruder alarm | | | | Open (Alarm) | Automatically after 3 s |
| Latched PIR (Memory) | | | | | Switch to Night mode |

Continuously on Normal blinking (1 Hz)

[1] Tri-colour LED.

Specifications

| | |
|-----------------------------|---|
| Detector | Dual |
| Range diameter (selectable) | 20 ± 0.5 m (65 ft. 7 in. \pm 1 ft. 7 in.) or 12 ± 0.5 m (39 ft. 4 in. \pm 1 ft. 7 in.) |

| | |
|--|--|
| Viewing angle (selectable) | 360 degrees or 180 degrees |
| Optical | 2 x 9 curtains |
| Microwave frequency | 5.8 GHz |
| Max microwave output at 1 m | 0.003 μ W/cm ² |
| Memory | Yes |
| Input power | 9 to 15 VDC (12 V nominal) |
| Peak-to-peak ripple | 2 V (at 12 VDC) |
| Detector start-up time | 45 s |
| Normal current consumption | 12 mA |
| Current consumption in Alarm | 10 mA |
| Maximum current consumption | 15 mA |
| Mounting height | 2.5 to 5.0 m (8 ft. 2 in. to 16 ft. 5 in.) |
| Target speed range | 0.3 to 3.0 m/s (1 ft./s to 9 ft. 10 in./s) |
| Alarm (NC) / Tamper relay characteristic | 80 mA, 30 VDC, Form C |
| Pry-off tamper (not evaluated by UL/cUL) | Optional |
| Alarm time | 3 s |
| Operating temperature | 0 to 49°C (32 to 120°F) |
| Dimensions (Ø x H) | Ø 138 x 92 mm (Ø 5.43 in. x 3.62 in.) |
| Relative humidity | max. 95% |
| Weight | 255 g (9 oz.) |
| IP/IK rating | IP30 IK02 |

The product must be connected to a listed burglar system compatible control unit or power supply unit, which provides a minimum 4 hours of standby power.

Perform walk test at least one per year.

Use only a listed power-limited supply.

Certification and compliance

Manufacturer UTC Fire & Security Americas Corporation, Inc.
1275 Red Fox Rd., Arden Hills, MN 55112-6943, USA

Authorized EU manufacturing representative:
UTC Fire & Security B.V.
Kelvinstraat 7, 6003 DH Weert, Netherlands

Certification **CE**

FCC This device complies with Part 15 of the FCC rules.

Compliance Operation is subject to the following two conditions:

1. This device may not cause harmful interference.
2. This device must accept any interference received, including interference that may cause undesired operation.

FCC ID: YFYDD669-U



2002/96/EC (WEEE directive): Products marked with this symbol cannot be disposed of as unsorted municipal waste in the European Union. For proper recycling, return this product to your local supplier upon the purchase of equivalent new equipment, or dispose of it at designated collection points. For more information see: www.recyclethis.info.

Contact information

For contact information see our Web site:
utcfireandsecurity.com.