



360 Herndon Parkway
Suite 1400
Herndon, VA 20170
<http://www.rheintech.com>

Work Order: 2002018Revision: 2
Quote Number: QRTL02-241 Revision:
FCC CFR 47 Rules and Regulations
Industry Canada Standard(s)

APPENDIX I: MANUAL

PHS Desktop Telephone
PHS Desktop Telephone

MODEL UTS600

Instruction Manual

CONTENTS

<u>WARNING! FCC RF EXPOSURE COMPLIANCE</u>	1
1. BEFORE USING THIS PRODUCTS	2
1.1 EXPLANATION OF ALERT SYMBOLS USED IN THIS MANUAL	2
1.2 FOR SAFE OPERATION - IT IS IMPORTANT YOU READ THIS	3
■ Telephone handling instructions.....	3
FOR SAFE OPERATION - IT IS IMPORTANT YOU READ THIS (continue)	4
1.3 FOR SAFE OPERATION - IT IS IMPORTANT YOU READ THIS	5
■ AC Adapter handling instructions.....	5
FOR SAFE OPERATION - IT IS IMPORTANT YOU READ THIS (continue)	6
1.4 CAUTION OF USING	7
1.5 FEATURES OF DESKTOP TELEPHONE UTS600	8
■ Benefits.....	8
1.6 CHECK PACKAGE CONTENTS	9
1.7 NAMES AND FUNCTIONS	10
2. OPERATION	12
2.1 PREPARATION	12
2.2 Antenna Orientation.....	13
Antenna Type Determination Guidelines.....	13
Main Unit Site Selection.....	14
Installation Accessories, Standard and Special Tools.....	14
Coaxial Cable Installation.....	16
Antenna Installation.....	17
2.3 OPERATION	21
■ Placing a Call.....	21
■ Receive a Call.....	22
3. MAINTENANCE	22
4. SPECIFICATIONS	22

WARNING! FCC RF EXPOSURE COMPLIANCE

This PCS base station complies with the Federal Communications Commission (FCC) RF exposure limits for General Population/Uncontrolled exposure environment. In addition, it complies with the following Standards and Guidelines:

- FCC 96-326, Guidelines for Evaluating the Environmental Effects of Radio-Frequency Radiation.
- FCC OET Bulletin 65 Edition 01-01 (2001) Supplement C, Evaluating Compliance with FCC Guidelines for Human Exposure to Radio Frequency Electromagnetic Fields.
- ANSI/IEEE C95.1-1992, IEEE Standard for Safety Levels with Respect to Human Exposure to Radio Frequency Electromagnetic Fields, 3 kHz to 300 GHz.
- ANSI/IEEE C95.3-1992, IEEE Recommended Practice for the Measurement of Potentially Hazardous Electromagnetic Fields - RF and Microwave.

Antenna Installation Requirement:

The antenna(s) used for this transmitter must be installed to provide a separation distance of at least 20 cm from all persons and must not be co-located or operating in conjunction with any other antenna or transmitter.



1. BEFORE USING THIS PRODUCTS

1.1 **EXPLANATION OF ALERT SYMBOLS USED IN THIS MANUAL**

So that user can use this product in the correct safe manner, this instruction manual uses various alert symbols. These symbols are for the prevention of injury to the user or others and for the prevention of property damage.

The following shows the symbols and explains their meaning.

Please learn these symbols before reading this manual.

 DANGER	This symbol indicates that ignorance of the symbol and the instruction given together with it or erroneous on the product may cause an imminent hazard which directly results in personal serious injury or death.
 WARNING	This symbol implies a factor that may cause personal serious injury or death due to ignorance of the symbol and of the instructions given together with it or erroneous operations of the product.
 CAUTION	This symbol implies a factor that may cause personal injury or property damage due to ignorance of the symbol and of the instructions given together with it or erroneous operations on the product.

Example of alert symbols



This symbol indicates CAUTION (includes DANDER and WARNING), the pictures in the triangle show caution details.(The left picture shows a general warning.)



DO NOT
DISASSEBLE



DO NOT
PERFORM

These symbol indicate actions that must not be performed.

Carefully read the given instructions and DO NOT carry out these actions. (The left picture shows DO NOT DISASSEMBLE.)

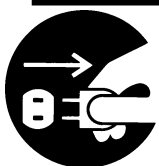

REMOVE
PLUG



INSTRUCTIONS

These symbol indicate actions that must be followed.

Carefully read the given instructions and always carry them out. (The left picture shows REMOVE PLUG.)

1.2 **FOR SAFE OPERATION - IT IS IMPORTANT YOU READ THIS**

■ Telephone handling instructions

WARNING

	Do not turn this telephone on where there is dust or flammable substance such as propane gas or gasoline.
Otherwise, it may cause fire or explosion	

	Do not insert any metal pieces or foreign matter into crevices on this phone.
Otherwise, it may cause electric shock or breakage.	

	Do not turn this telephone on near electronic equipment that uses sensitive controls or weak signals.
Use this phone may cause electric equipment to malfunction. Examples of sensitive electronic equipment include: Hearing aids, medical apparatus (pacemakers included), fire alarms, automatic doors and other automatic control equipment. If you are using a pacemaker or some other medical apparatus, ask medical apparatus makers or dealers about the effect which will be caused by the radio wave from the telephone.	

	When using in hospitals, always follow the directions of that medical facility
Otherwise, use of telephone may adversely affect medical electronic equipment.	

	Do not give it a strong shock or throw it.
Otherwise, it may cause breakage.	

	In the event that smoke (or strange odors) comes from this telephone, immediately
Otherwise, continued use may cause fire. Take it to the dealer promptly.	

	Do not disassemble or modify this telephone.
Otherwise, it may cause damage or an accident such as fire or injury.	

⚠ CAUTION

 Never attempt to dry your telephone if it gets wet by placing it in a microwave oven, also never place this phone in or on microwave ovens, high voltage containers or electronic cooking equipment.

 Do not get on this telephone. (Especially be careful with small children.)

Otherwise, it may cause injury by tumbling or breakage.

 Do not put this telephone in a dusty, humid or hot place.

Otherwise, it may cause a fire or a breakage.

 Do not put this telephone near heaters or fires.

Otherwise, it may cause a breakage.

1.3 **FOR SAFE OPERATION - IT IS IMPORTANT YOU READ THIS**

■ AC Adapter handling instructions

WARNING



Always use the designed power source.

Connecting to the wrong power source may cause a fire or breakage.



Do not make a short circuit between the DC output terminals.

Otherwise, it may cause breakage, fire or injury.



Do not insert any metal pieces or foreign matter into crevices on this phone.

Otherwise, it may cause electric shock or breakage.



Do not swing the AC adapter by holding the cord.

Otherwise, it may cause breakage and injury by hitting you or others.



In case of dropping or breaking AC adapter, immediately unplug AC adapter from AC outlet.

Otherwise, it may cause an electric shock or breakage. Take it to the dealer promptly.



Do not handle AC adapter or DC plug of the AC adapter with wet hand.

Otherwise, it may cause an electric shock.



Do not damage AC adapter by forcefully bending or bundling the AC adapter cord.

Otherwise, it may cause an electric shock or fire.



Do not place heavy items on AC adapter cord and do not modify it.

Otherwise, it may cause an electric shock or fire.

FOR SAFE OPERATION - IT IS IMPORTANT YOU READ THIS (continue)



In the event that smoke or strange odors from AC adapter, unplug the AC Adapter from the AC outlet immediately.

Otherwise, continued use may cause a fire or electric shock.
Repairing by yourself is dangerous, so take it to the dealer promptly.



If the AC adapter is exposed to water, unplug the AC adapter from the AC outlet immediately.

Otherwise, it may cause a fire, electric shock or emission.



Do not use table tap, divergence point or divergence socket adapter to put many loads on one AC outlet.

Otherwise, it may cause a fire.



Do not leave pr use in direct sunshine or places with high temperature.

Otherwise, it may cause a fire.



Unplug AC adapter from AC outlet during thunder shower.

Otherwise, it may cause a fire, electric shock and breakage.



Always use the designated AC adapter.

Using AC adapter may cause a breakage.



Do not get on the AC adapter.

(Especially, be careful with small children.)

Otherwise, it may cause injury by tumbling or breaking.



Always unplug the AC adapter to be by holding its case.

Pulling the AC adapter by its cord may cause cord damage, with may result in fire or sock.

1.4 **CAUTION OF USING**

■ **About water and rain**

Do not use it in bathroom or plunge it into water.

Try to avoid telephone from getting wet by rain drops etc.

If the phone gets wet, immediately wipe it with dry cloth.

■ **Operating environment**

You may hear some noise when cars or motor cycles pass by.

You may hear some noise or your phone call may be cut off if you use it by OA equipment or electrical equipment.

You may hear some noise or your phone call may be cut off if you use it near a microwave oven because of the electromagnetic waves.

If you use this telephone near the TV or radio, the screen may get messy or you may hear some noise.

Try to use this telephone where it can get strongest radio wave. The usable area can be restricted by the surrounding environment (wall, furniture etc.).

Radio waves can be jammed by material of furniture, so avoid using it near them.

1.5 **FEATURES OF DESKTOP TELEPHONE UTS600**

UTS600 Desktop Telephone is a digital wireless telephone that incorporated PHS digital cordless-phone technology in an ordinary touch-tone telephone.

- UTS600 connects wirelessly to existing PHS network rather than a landline.
- UTS600 operates just like an ordinary wire-line telephone.

You pick up the handset, hear a dial tone, and enter the phone number on the keypad and waits for a connection.

UTS600 includes common wire-line phone features such as call waiting, redial and hook flash, which can be accessed with a single key.

■ **Benefits**

- High Voice Quality
- Removable Whip Antenna
- External Directional High-gain Antenna (Option, Ga=10dBi, 14dBi)
- External Power Supply Unit with built-in back-up battery (Option)
- External Earphone & Microphone Jack for FAX
- 3 Function keys

1.6 CHECK PACKAGE CONTENTS

Check package components after opening box.

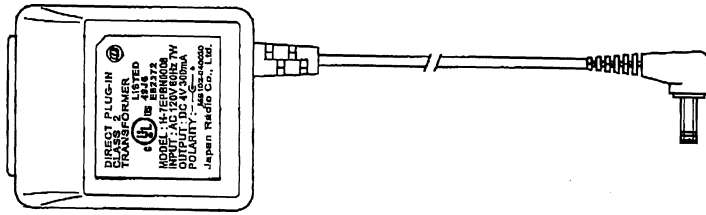

AC Adapter

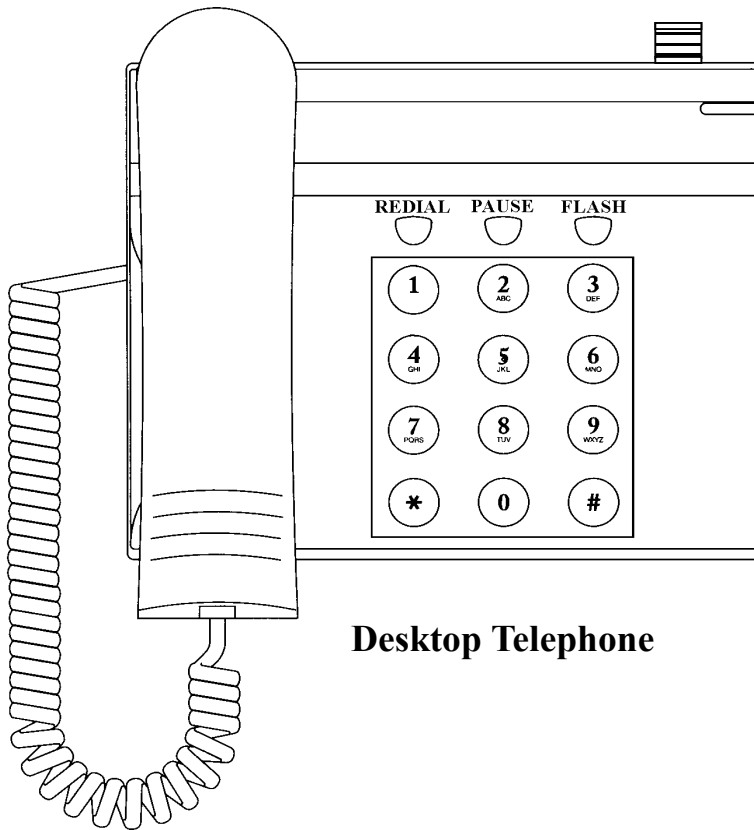

Desktop Telephone

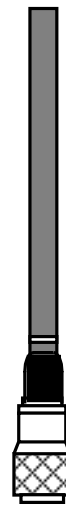

Whip Antenna

1.7 NAMES AND FUNCTIONS

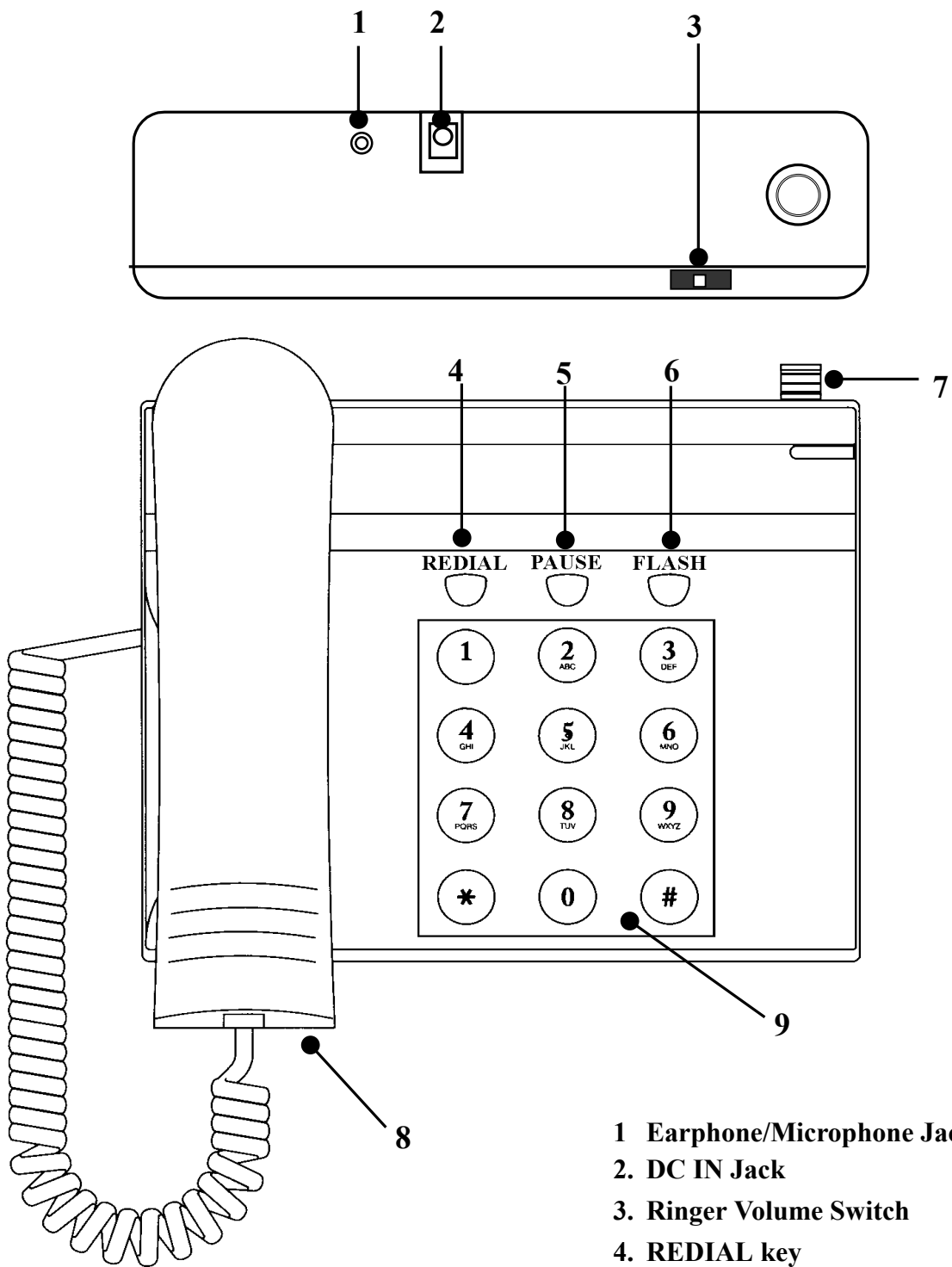

- 1 Earphone/Microphone Jack
- 2 DC IN Jack
- 3 Ringer Volume Switch
- 4 REDIAL key
- 5 PAUSE key
- 6 FLASH Key
- 7 Antenna Connector
- 8 Handset
- 9 Keypad

a. Earphone/Microphone Jack

Connect earphone and external microphone instead of handset receiver and microphone.

b. DC IN Jack

DC Power supply connector for telephone.
Connect DC plug of attached AC adapter

c. Ringer Volume Switch

Select Ringer Sound Level by this switch to "High" or "Low".

d. REDIAL Key

Press this key to place a call by redial.

e. PAUSE Key

Press this key to hold a conversation.

f. FLASH Key

Press this key to use "Hook Flash" function.

g. Antenna Connector

Connect attached whip antenna or an external high gain antenna (option).

h. Handset

i. Key Pad

2. OPERATION

2.1 **PREPARATION**

Connect Whip Antenna to Desktop Telephone antenna connector.

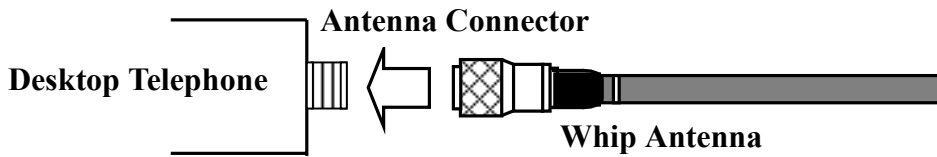

Flex the Whip Antenna as shown below.

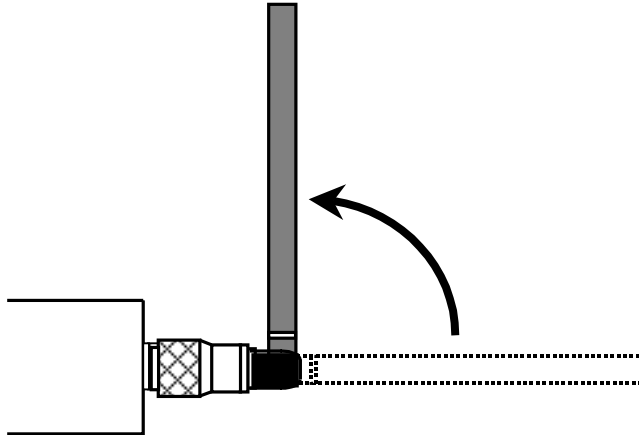

Insert AC plug of AC adapter into AC outlet, and insert DC plug into the Desktop Telephone DC IN jack..

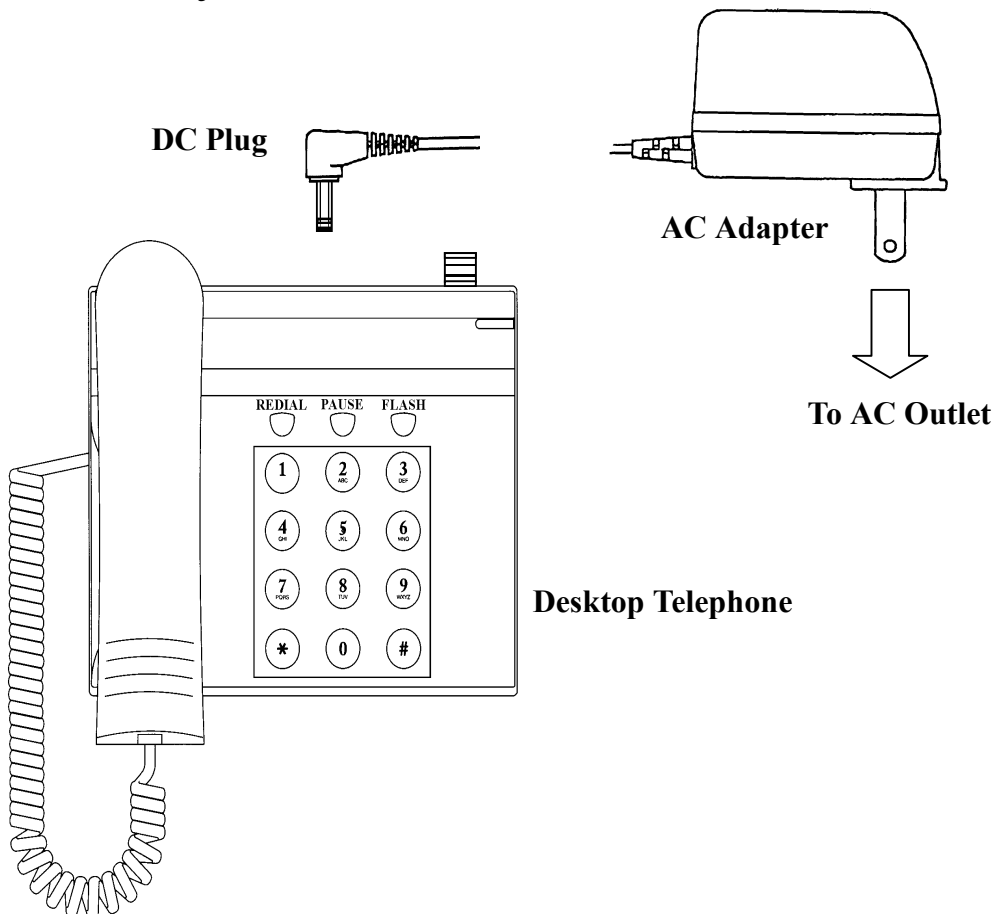

2.2 Antenna Orientation

Careful placement of the antenna is necessary to ensure clear reception. Position the antenna so that it is:

- In clear view of a Radio Port
- Not blocked by buildings, summer foliage nor heavy traffic of large vehicles
- At least 2 meters in height, use Coverage Map and on-site measurements to determine exact height, usually 2 meters or higher
- Directed towards the strongest RSS measurement, for directional antenna only
- On a wall or pole that is sufficiently strong, make sure wall or pole can withstand winds common to the area
- Away from other objects such as poles, trees, buildings, and so on that block the signal from the Radio Port; in general the minimum distance is 750 mm.

Antenna Type Determination Guidelines

The Coverage Map shows Radio Port locations and the area covered by the RP. The type of antenna installed depends on its distance from the Radio Port. In general:

If distance is...	Then use...
Less than 500m	4.5 dBi omni or directional antenna
Between 400m and 700m	7 dBi omni or directional antenna
Greater than 700m	10 dBi directional antenna

Table 2-1: Antenna Type Determination Guidelines

There may be exceptions to the requirements in Table 2-1 identified by on-site RSS measurements and/or by the specific radio environment.

Main Unit Site Selection

Choose a suitable location for the FSU Main Unit. Make sure the site will not expose the device to:

- Direct sunlight
- Dampness or moisture
- Dust
- Magnetic fields
- Vibration
- Extremes of heat, cold or humidity.

Install the FSU on a stable surface, such as a desk or wall. Consider the length of the AC Adapter cord in determining the Main Unit's location. To avoid possible interference from the connected telephone, make sure the Main Unit is installed at least 1 meter away. To minimize the length of coaxial cable between the main unit and the antenna, position the indoor main unit as close as possible to the outdoor antenna.

Note : Make sure that the FSU Main Unit is positioned so that the green LEDs are visible to the subscriber. When reporting trouble, the subscriber will be asked the status of the LEDs.

Installation Accessories, Standard and Special Tools

This section lists all the equipment needed for and FSU installation. Be sure to have all of these items on hand before beginning.

Accessories:

- Coaxial cable
- Coaxial cable connector (2 pieces)
- Marker
- PVC tape
- Self-adhesive rubber tape
- Earth cable
- Solderless grounding terminal (optional)
- Bracket for cable

- U-bolt for pole mount
- Terminal lug
- Terminal lug crimper

Note : In areas where lightning may strike, a lightning protector is required.

Standard Installation Tools:

- Wire cutter
- Adjustable wrench
- Pliers
- Cutter
- Flat screwdriver
- Phillips (or Plus) screwdriver
- Electric drill
- Step ladder
- AC power extension cord

Special Tools for Cable Termination:

- Cable stripper
- Crimper

Antenna Orientation Instruments:

- Map
- Compass
- Binoculars

Measuring Receiver or Equivalent:

- Measuring receiver
- Memory card
- AC adapter
- Adapter (3-poles→2-poles conversion)

- Coaxial cable adapter TNC-J/SM-J (optional)
- 5 meters of coaxial cable (optional)
- Power cable

Coaxial Cable Installation

Once the locations for the antenna and the main unit have been determined, use the procedures in this section to install the cable.

1. Measure and cut a length of cable to fit between the main unit and the antenna.
2. Run the cable between the main unit and the antenna.
3. Using the cable stripper, strip both ends of the coaxial cable. Refer to the figure below for exact dimensions to strip.

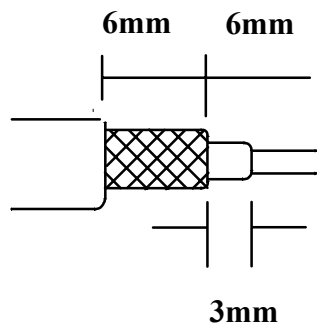

Figure 2-1: Stripped Coaxial Cable

4. Carefully mount the coaxial cable terminals onto the cable ends.
5. Affix the cable terminals using the crimper.

Antenna Installation

NOTE : The antenna shown in this manual is one of the three types of antennae used in the UTStarcom-WLL system.

1. Unpack the FSU Antenna and accessories. Make sure all parts are in good condition. The FSU Antenna and accessories are shown in Figure 2-2.

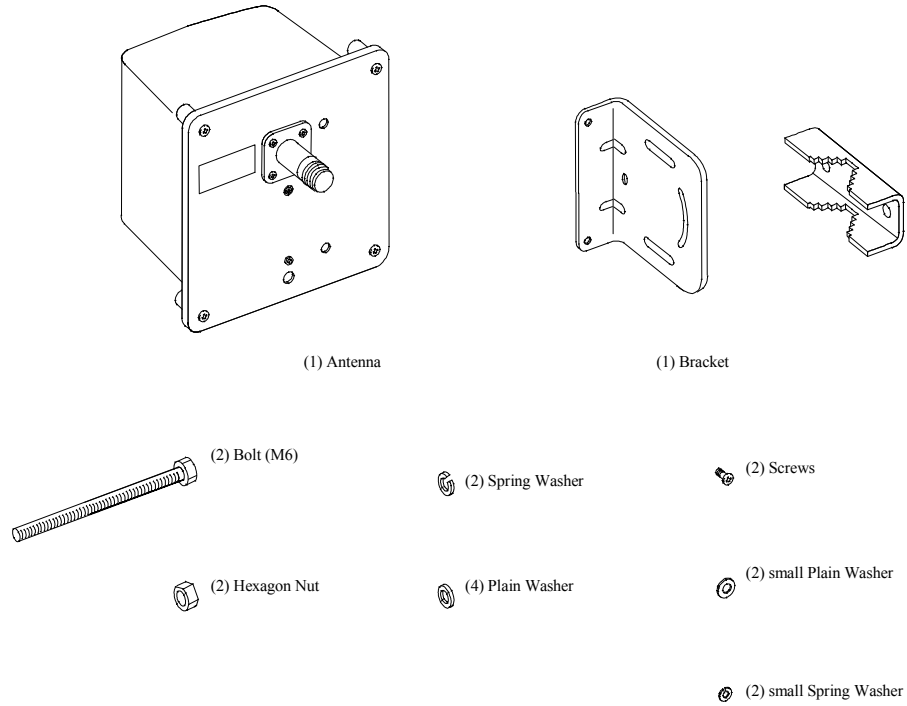

Figure 2-2 : FSU Antenna and Accessories

2. Assemble the FSU antenna by attaching the bracket to the antenna according to Figure 2-3.

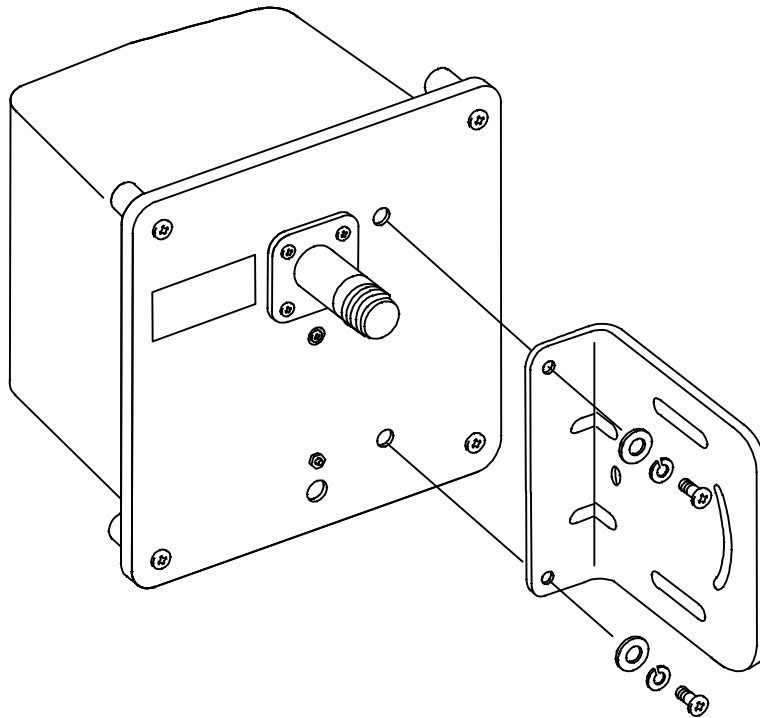

Figure 2-3: Antenna Bracket Assembly

3. After installing the antenna, use the PHS Signal Analyzer to check the receiving signal level. Measure the reception level (RX LVL) at the TNC connector on the FSU. Target values are as follows:
 - RX LVL: more than -78dBm (35dB μ V)
 - Frame Error Rate: less than 2%

4. At the site selected for the FSU antenna, tentatively mount the antenna and take several RSS measurements approximately 15 cm from the antenna. Position the antenna where it receives that strongest signal. Then mount the antenna on a pole. Refer to the figure below for assembly of the bracket onto the pole

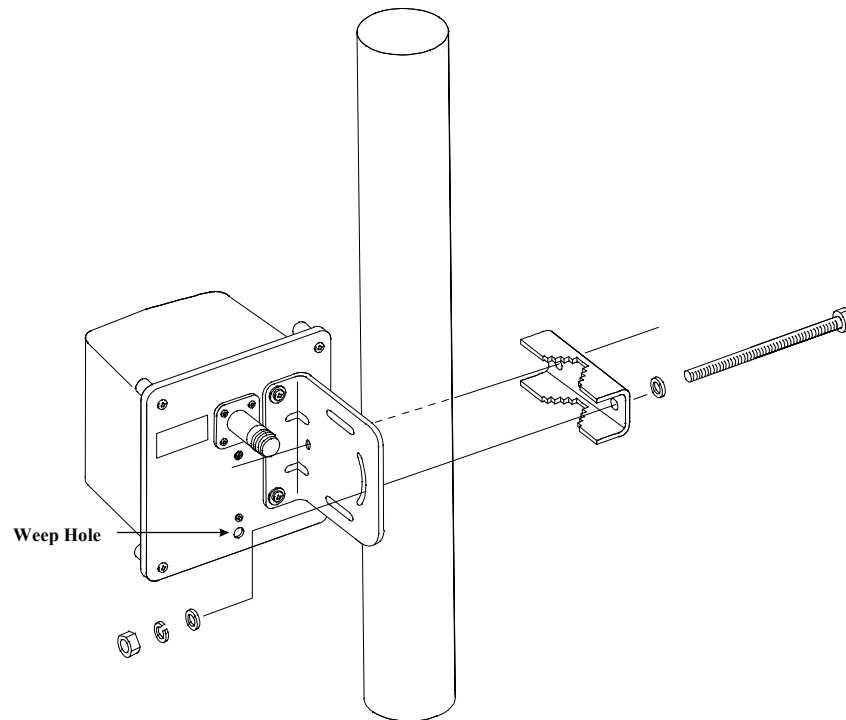

Figure 2-4 : Antenna Mounted On Pole

Note : Make sure that the weep hole is positioned at the lower edge of the antenna bracket as shown in Figure 2-4.

5. After installing the antenna, use the PHS Signal Analyzer to check the receiving signal level. Measure the reception level (RX LVL) at the TNC connector on the FSU. Target values are as follows:
 - RX LVL: more than -78 dBm (35 dB μ V)
 - Frame Error Rate: less than 2%

WARNING : DEPENDING ON LOCATION, IT MAY BE NECESSARY TO GROUND THE ANTENNA TO PREVENT DAMAGE BY LIGHTNING. REFER TO THE FIGURE BELOW FOR A DIAGRAM OF THE EARTH CABLE CONNECTION.

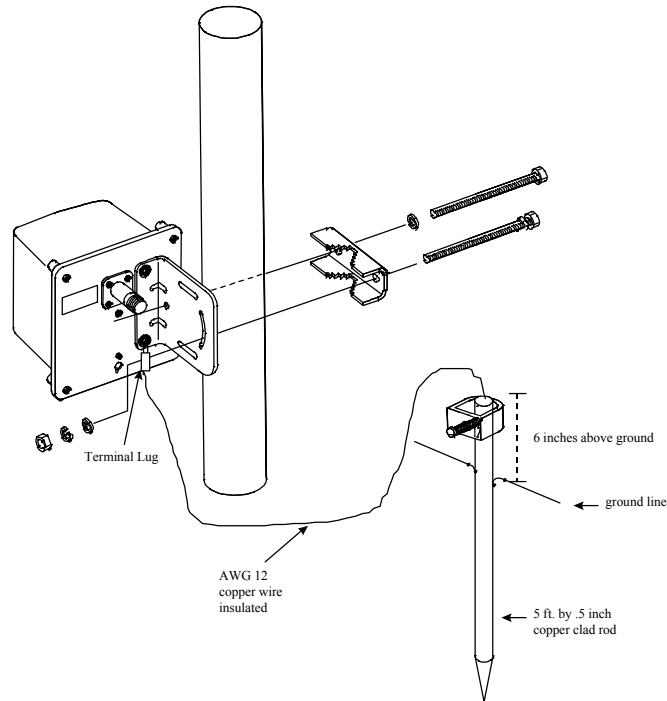

Figure 2-5 : Earth Cable Connection

6. Attach a terminal lug to the lower bracket screw and tighten screw.
7. Plug insulated copper wire into the terminal lug and use the terminal lug crimper to affix the copper wire to the terminal lug.
8. Attach the other end of the copper wire to a copper clad rod as shown in the figure above.

9. Connect the coaxial cable to the antenna as shown in Figure 2-6.

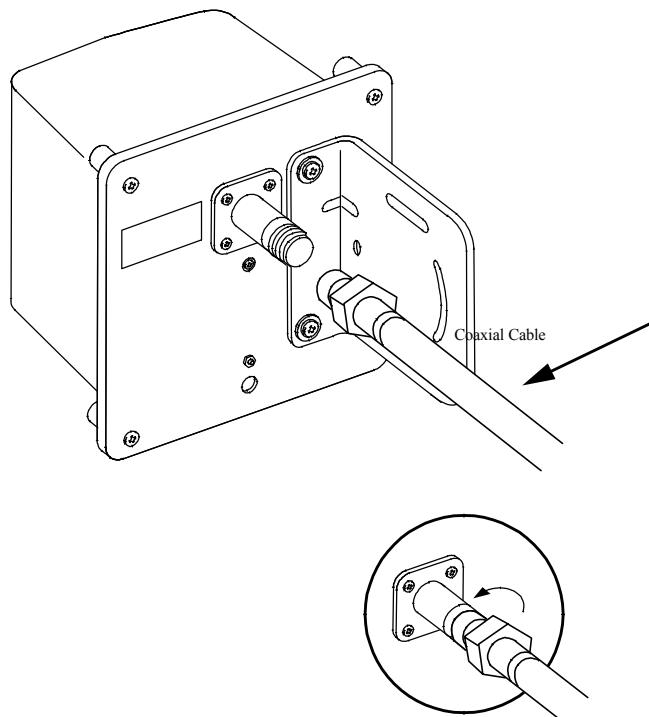

Figure 2-6 : Coaxial Cable Connection to Antenna

10. Wrap the cable connection first with the self-adhesive rubber tape. Stretch the tape until it is $\frac{1}{2}$ its original width. Then wrap the PVC tape around the rubber tape.

2.3 OPERATION

Desktop Phone will start its function when you insert the DC plug into DC IN jack. It will communicate with PHS base station automatically, and operation will be available after few seconds.

■ Placing a Call

Pick up handset.

Dial tone will be heard from the handset receiver.

Dial a telephone number of your party.

Ring-back tone will be heard from handset receiver.

When your party answer your call, conversation will be available.

Hang up the handset when you finish the conversation.

You can call the party you last called by depressing "REDIAL" key for less than 1 second after hearing dial tone.

- **Receive a Call**

Ringtone will be heard from desktop telephone when it receives a call. Conversation will be available when you pick up the handset.

- **Placing a call on hold**

Place a call on hold by depressing "PAUSE" key when you want to temporarily stop the conversation.

While the other party is placed on hold, they can not hear you.

They hear a hold melody during holding.

You can go back to the conversation by depressing "PAUSE" key again.

- **Using the Flash function**

You can catch the another call during conversation by depressing "FLASH" key.

3. MAINTENANCE

Whip it with a dry soft cloth.

When the dirt is too much, use a diluted neutral detergent with a well wrung towel, then wipe with a dry soft cloth.

Do not use benzene, thinner or alcohol.

It may cause color-change or deterioration of the paint or writing.

4. SPECIFICATIONS

Radio frequency band 1,900MHz

Transmission power 10mW

Power source DC 4V, 300mA

External dimensions Approximately 197 (width) x 162 (depth) x 85.5 (height) mm

Mass Approximately 650g