



# Wireless Local Loop

## RPC/RP Installation & Configuration Manual

WLL-RPC/RP-IN/UM-1.0

June 19, 2000

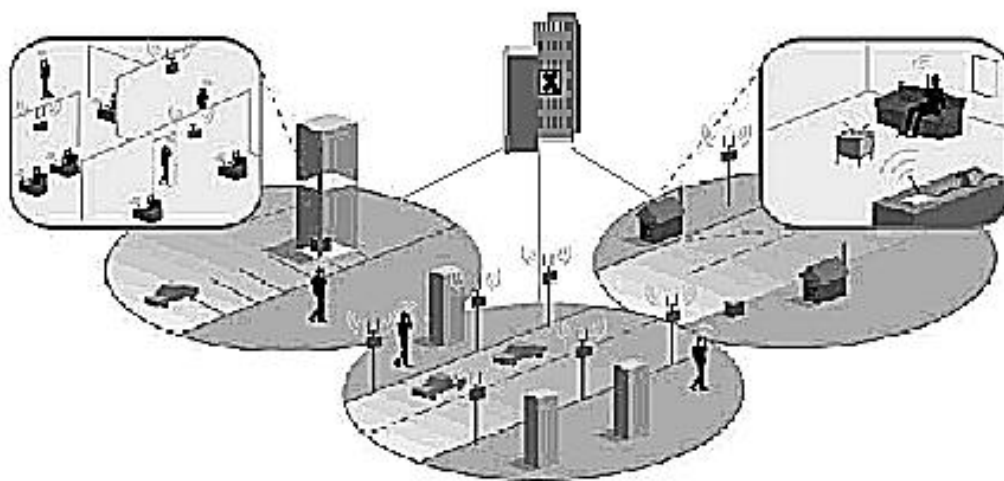

Compiled by (Joseph) Guangping Zhang

© Copyright 2000 UTStarcom Inc. All Rights Reserved.

This manual has been prepared for UTStarcom customers, UTStarcom personnel, and licensees. The information contained herein is the property of UTStarcom Inc. and shall be neither reproduced nor utilized in any form or by any means, electronically or mechanically, in whole or in part, without prior written approval from UTStarcom Inc.

# Important Safety Instructions



## Safety Information:

### Installer and User WARNING

The device is to be installed and operated at a “fixed location”. The term "fixed location" means that the device is physically secured at one location and is not able to be easily moved to another location.

It must be located - (for indoor RPs) up on or near the ceiling away from users or bystanders – (for outdoor RPs) on the roof top site, pole, building, or traffic light away from users or bystanders. It must be mounted in a manner to ensure that a minimum separation distance of 20cm is normally maintained between all users, bystanders and the antenna (including any radiating structure).

The installer may be required to perform an MPE evaluation and an Environmental Assessment (EA) of the location at the time of licensing per CFR 47 Part 1.1307. Fixed mounted antennae that are co-located with other antennae must satisfy the co-location requirements of Part 1.1307.

### Limits:

The limit for general population/uncontrolled environment exposures is 1  $mW / cm^2$  for the band 1895-1910 MHz.

### MPE evaluation:

The following calculations are provided for the more restrictive limit: uncontrolled environment/general population.

The calculated minimum safe distance, Radii(cm), is approximately 10 times lower than the minimum required installation distance of 20 cm per Part 2.1091.

Therefore, the transmitter model numbers EA7H74B and EA7H75B complies with the MPE requirements by providing a safe separation distance between the antenna (including any radiating structure) and any persons.

The calculations were performed using formulas found in OET Bulletin 65 Edition 97-01(1997).

### Transmitter Specifications:

Antenna Type	Gain (dBi)	Output power EIRP (dBm)	Output Power (dBm)	Base stations M/N	Minimum Installation Distance (cm)
Built-in	2.4	21.4	19 dBm (Peak)	EA7H74B	20
	2.4	12.4	10 dBm (avg)	EA7H74B	20
Omni-Directional	7	26	19 dBm(Peak)	EA1H75B	20
	7	17	10 dBm (avg)	EA1H75B	20

### MPE Radii (m) For general population/uncontrolled environment

Power P(W) Max. Peak	Antenna G numeric	Radii(cm)	Base stations M/N
0.08	1.7	1.5	EA7H74B
0.08	5.0	2.5	EA1H75B

## General Safety Instructions:

- The sign on the top right corner is intended to alert the user the presence of important operation and maintenance (service) instructions in the literature accompanying the product. Also notice warnings such as “WARNING!” or “CAUTION.”
- When installing, operating, or maintaining the system, please follow the basic safety procedures in order to reduce the risk of fire, electric shock, and injury to persons, as listed below:
- Read and understand all instructions.
- Follow all warnings and instructions marked on this product.
- For information on proper mounting instructions, consult the Installation Manual provided with this product.
- Install only equipment identified in the Installation Manual provided with this product. Use of other equipment may result in improper connection of circuitry leading to fire or injury to persons.

- The telecommunication interfaces should not leave the building unless connected to telecommunication devices providing primary and secondary protection, as applicable.
- This product should only be operated from the type of power source indicated on the marking label.
- This equipment must be provided with a readily accessible disconnect device as part of the building installation.
- Installation must include an independent frame ground drop to building ground. Refer to installation instructions.
- Do not use this product near water, for example in a wet basement.
- Do not place this product on an unstable cart, stand, or table. The product may fall, causing serious damage to the product.
- Use caution when installing or modifying telecommunications lines.
- Never install telecommunications wiring during a lightning storm.
- Never install telecommunications in wet locations.
- Never touch uninsulated telecommunications wires or terminals unless the telecommunications line has been disconnected at the network interface.
- Never touch uninsulated telecommunications wires or terminals carrying direct current or ringing current or leave this wiring exposed. Protect and tape such wiring and terminals to avoid risk of fire, electric shock, and injury to service personnel.
- Never push objects of any kind into this product through slots as they may touch dangerous voltage points or short-out parts that could result in a risk of fire or electrical shock. Never spill liquids of any kind on this product.
- Slots and openings in the unit are provided for ventilation, to protect it from overheating. These openings must not be blocked or covered. This product should not be placed in a built-in installation unless proper ventilation is provided.
- To reduce the risk of an electrical shock, do not disassemble this product. Service should be performed by trained personnel only. Opening or removing covers and/or circuit boards may expose you to dangerous voltages or other risks. Incorrect re-assembly can cause electrical shock when the unit is subsequently used.

- This equipment is intended for installation in restricted access locations where access is controlled or where access can only be gained by service personnel with a key or tool. Access to this equipment is restricted to qualified service personnel.

**Save These Instructions!**

# Table of Contents

<b>1 INTRODUCTION .....</b>	<b>1-1</b>
1.1 PURPOSE.....	1-1
1.2 ORGANIZATION .....	1-1
1.3 DOCUMENTATION CONVENTIONS .....	1-2
<b>2 RPC INSTALLATION .....</b>	<b>2-1</b>
2.1 GENERAL DESCRIPTION.....	2-1
2.1.1 Main RPC Features.....	2-2
2.1.2 RPC Module Descriptions.....	2-3
2.1.2.1 Enhanced Control Module .....	2-4
2.1.2.2 E1 Interface Module .....	2-5
2.1.2.3 Radio Port Interface Module .....	2-7
2.1.2.4 Application Software Loading Module .....	2-9
2.1.2.5 ADPCM Highway.....	2-10
2.2 SYSTEM CONSTRUCTION .....	2-10
2.3 INSTALLATION.....	2-12
2.3.1 Before Beginning.....	2-12
2.3.2 RPC Site Selection.....	2-12
2.3.3 Tools Required.....	2-13
2.3.4 Installation Instructions.....	2-13
<b>3 RP INSTALLATION .....</b>	<b>3-1</b>
3.1 GENERAL DESCRIPTION.....	3-1
3.1.1 Traffic Handling.....	3-3
3.1.2 Cell Overlap .....	3-5
3.1.3 Air Interface Handling.....	3-6
3.2 SYSTEM CONSTRUCTION .....	3-8
3.3 INDOOR RP INSTALLATION INSTRUCTIONS .....	3-10
3.3.1 Before Beginning.....	3-10
3.3.2 Site Selection .....	3-11
3.3.3 Indoor RP Installation .....	3-11
3.4 OUTDOOR RP INSTALLATION INSTRUCTIONS.....	3-13
3.4.1 Before Beginning.....	3-14
3.4.2 Outdoor RP Installation.....	3-14
<b>4 RPC/RP CONFIGURATION .....</b>	<b>4-1</b>
4.1 INITIALIZE AN RPC NODE.....	4-1
4.1.1 Background Map.....	4-5
4.1.2 Add RPC Icons on the Map .....	4-7
4.1.3 Add RP Icons.....	4-9
4.2 RPC CONFIGURATION .....	4-11
4.2.1 Set Time.....	4-12
4.2.2 RPC Change .....	4-13
4.2.3 Unit Control.....	4-13
4.2.3.1 Blockade/Unblockade.....	4-14
4.2.3.2 TimeSlot Layout .....	4-16
4.2.3.3 Maintenance.....	4-17
4.2.3.4 Change Master RP.....	4-18
4.2.3.5 RPC Synchronization .....	4-18
4.2.3.6 Online Trace .....	4-20
4.2.4 Function Status.....	4-21

4.2.4.1	RPC Status .....	4-22
4.2.4.2	RP Status .....	4-23
4.2.4.3	RP-I/F Board Status .....	4-28
4.2.4.4	E1 Signal Status .....	4-29
4.2.4.5	E1 Interface Status .....	4-30
4.2.4.6	Air Channel Status .....	4-31
4.2.4.7	Time Slot Status .....	4-32
4.2.5	Self Messages.....	4-33
4.2.6	Reset RPC.....	4-34
4.2.7	Antenna Information.....	4-36
4.2.8	RPC Connection.....	4-37
4.2.9	Version Window.....	4-37
4.3	MANAGE RPC DATA .....	4-38
4.3.1	Program Load .....	4-38
4.3.2	Program Switch.....	4-40
4.3.3	Data Load.....	4-41
4.3.4	Data Switch.....	4-42
4.3.5	Read Data .....	4-43
4.3.6	Write Data .....	4-44
4.3.7	Copy Data.....	4-46
4.3.8	Edit Data.....	4-46
4.3.8.1	Service Data 1: RP Installation .....	4-47
4.3.8.2	Service Data 2: Group Control Configuration.....	4-48
4.3.8.3	Service Data 3: System Parameters .....	4-50
4.3.9	Change Data (RP Installation).....	4-58
4.3.10	Change Data (E1-IF Board Installation).....	4-60
4.3.11	Change Data (Data Value).....	4-61
4.4	MANAGE RPC ALARMS.....	4-62
4.4.1	Warning Status.....	4-62
4.4.2	Alarm History.....	4-63
4.5	RESET RPC.....	4-64
4.6	RPC STATISTICS .....	4-67
4.6.1	RPC Traffic Report .....	4-67
4.6.2	RPC Outstanding Alarms .....	4-69
4.6.3	RP Status Report .....	4-70
<b>A</b>	<b>SPECIFICATIONS .....</b>	<b>A-1</b>
A.1	RPC SPECIFICATIONS .....	A-1
A.1.1	Champ Connector Pin Assignments.....	A-2
A.2	RP SPECIFICATIONS .....	A-4
A.2.1	Radio Features.....	A-4
A.2.2	Outdoor Type RP .....	A-4
A.2.2.1	Antenna .....	A-5
A.2.3	Indoor Type RP.....	A-5
<b>B</b>	<b>GLOSSARY.....</b>	<b>B-1</b>
<b>C</b>	<b>EDITOR'S NOTE .....</b>	<b>C-1</b>
C.1	NOTICE TO CUSTOMERS .....	C-1
C.2	HOW TO COMMENT ON THIS DOCUMENT .....	C-3
C.3	FEEDBACK FORM .....	C-5







---

# Introduction

# 1

---

## 1.1 Purpose

This manual describes the installation and configuration procedures for the Radio Port Controller (RPC) and Radio Port (RP). It is intended for the following customer personnel who participate in the engineering, installation, operations, and maintenance of the system.

- Equipment Engineers and outside plant engineers
- Installation, Operation, and Maintenance Personnel
- System Administrators
- Training Personnel

## 1.2 Organization

Listed below is the brief description of each chapter in this manual:

*Introduction* - Describes the contents of this manual and the conventions used.

*RPC Installation* - Details the steps necessary to install the Radio Port Controller.

*RP Installation* - Represents the procedures to install the Radio Port.

*RPC/RP Configuration* - Explains the configuration process for both the RPC and the RP.



*Appendix A: Specifications* – Describes the RPC/RP specifications and Champ connector pin assignments.

*Appendix B: Glossary* – Lists the meaning of the acronyms used in this manual.

*Appendix C: Editor's Note* – Provides the notice to the customers, customer service office addresses, and feedback form.

## 1.3 Documentation Conventions

Certain conventions are used in this document to denote types of information, such as commands, screen titles, options, and so on. The table below defines these conventions.

Style	Used For:	Example
<i>Italics</i>	Cited titles of books, chapters, and sections in the literature	<i>Performance Management</i>
<b>Bold</b>	Window and dialog box names, icon names, and field names	<b>Netman Database Window</b>
<b><u>Bold and Underlined</u></b>	Menu names	<b><u>Configuration</u></b>
<b><i>Bold and Italics</i></b>	Menu options, command, and button names	<b><i>Configure DLC</i></b>
 followed by <i>italic text</i>	Notes, cautions, and warnings	 NOTE: <i>This feature does not apply to RPC nodes.</i>
Initial Capital Letters	Names of functions, window tabs, and directory and file names	Double click the E1 Port Index field.
<b>&lt;Angled Brackets with Bold and Italicized Contents&gt;</b>	Variable sytem output	The status displayed is <b>COMM</b> <b>&lt;DLC#&gt;</b>

**Table 1-1: Documentation Conventions**



---

# RPC Installation

# 2

---

## 2.1 General Description

The Radio Port Controller (RPC) functions as the controller and power distributor for the Radio Ports (RPs). It is also the concentrator of the speech paths and the protocol converter for the PHS protocol and the Q.931 protocol. It has Dual Tone Multi Frequency (DTMF) senders for dialing to the Local Exchange (LE) through the Central Office Terminal (COT). In addition, the RPC synchronizes the associated RPs by extracting the synchronous clock from the E1 line connected to the COT and distributing it to all of the associated RPs.

RPCs can be co-located with a COT or located remotely and communicate with the COT using E1 transmission over:

- High Density Subscriber Loop (HDSL)
- Fiber Optic Transmission (FOT)
- Digital microwave radio

Figure 2-1 presents an overview of the RPC and RPs in the WLL system.

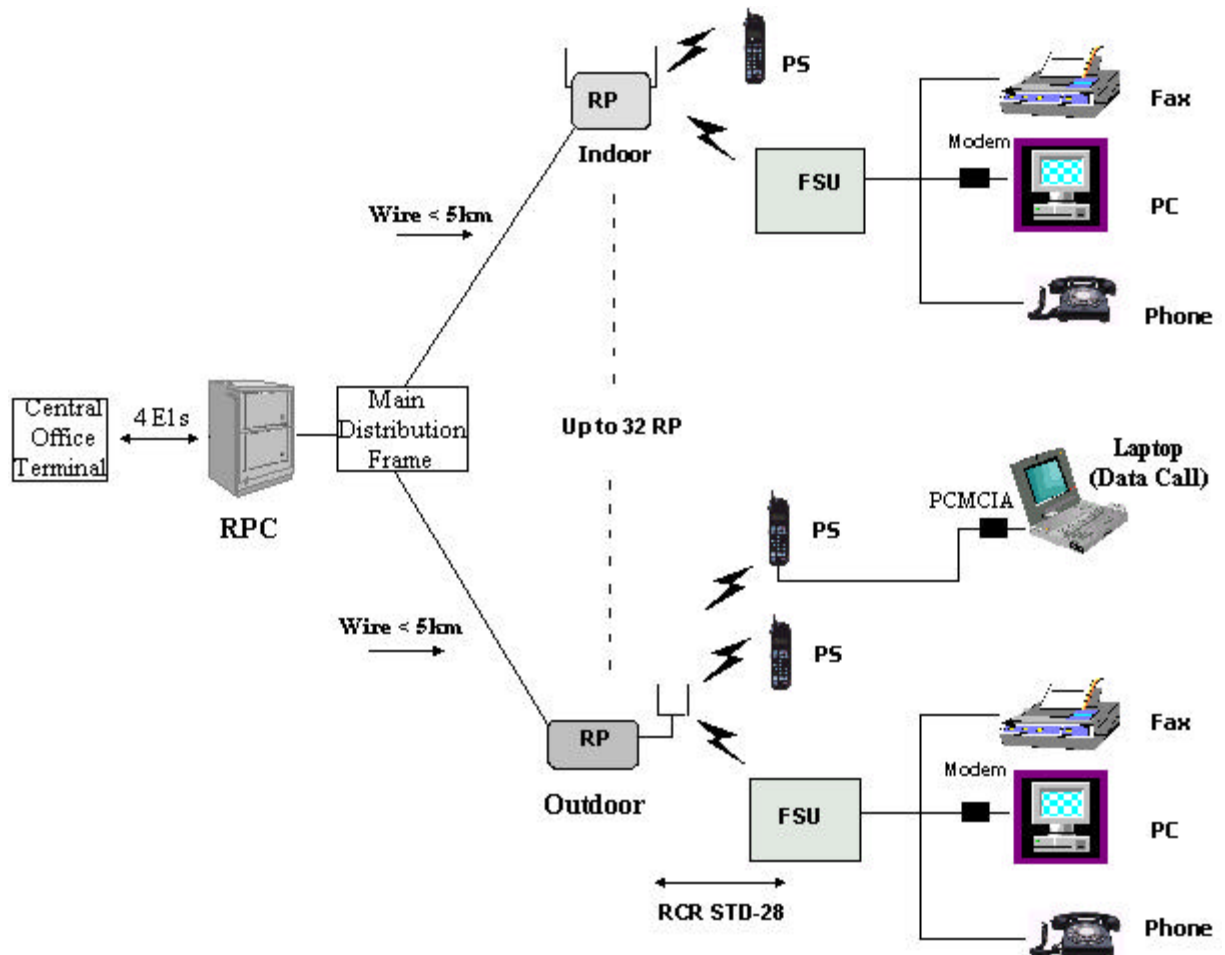

Figure 2-1: RPC in the WLL System

### 2.1.1 Main RPC Features

An RPC consists mainly of four types of function modules:

- One ECNT (Enhanced Control) module
- Up to four E1IF (E1 Interface) modules
- Up to eight RPIF (RP Interface) modules
- One APL (Application Software Loading) module - Optional

Figure 2-2 displays the four types of the function modules in the RPC.

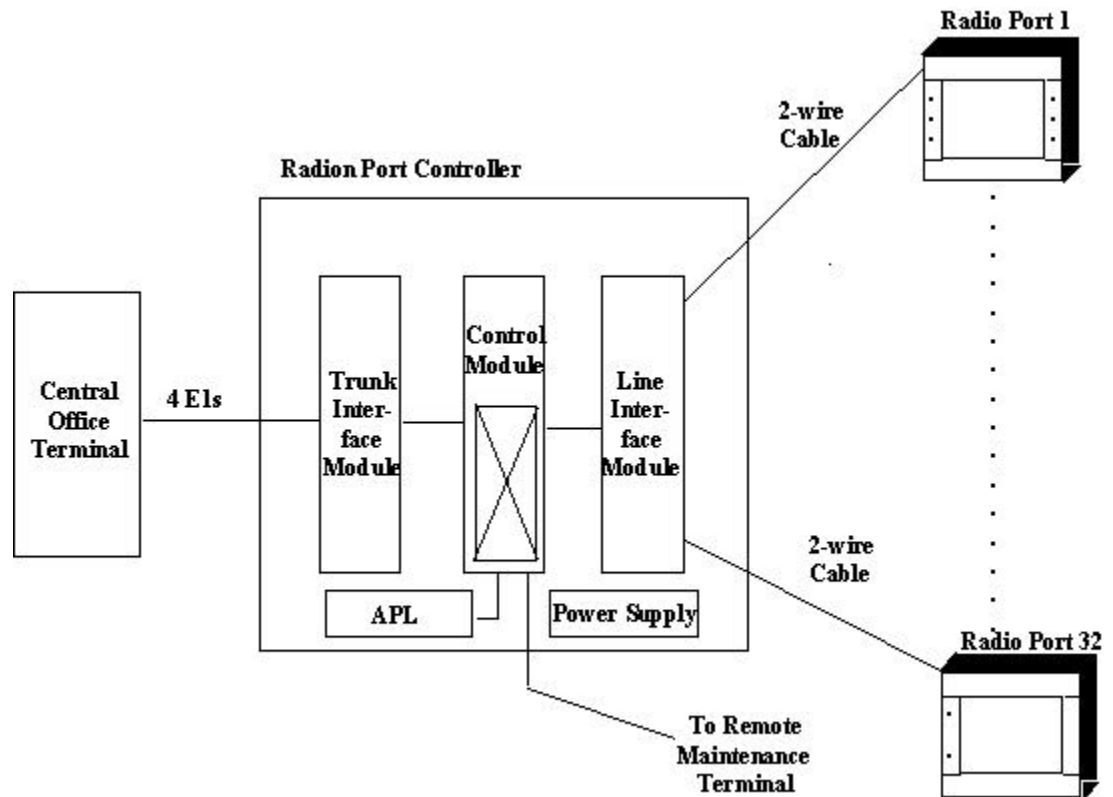

**Figure 2-2: Function Modules inside the RPC**

Each RPC can handle traffic loads of up to 120 simultaneous telephone calls. Four E1 trunks connect to the COT side and support 30 subscriber channels each. In normal traffic conditions, a single RPC can service approximately 1000 subscribers.

The RPC is monitored and controlled from the network management system connected to the COT. With this setup the program data, the operation data, and the system parameters can be changed and the alarm information and traffic data can be gathered easily.

## 2.1.2 RPC Module Descriptions

The following sections describe the RPC component modules, including the physical configuration, Light Emitting Diodes (LEDs), and switch operations.



### 2.1.2.1 Enhanced Control Module

The ECNT module provides the Operation, Administration and Maintenance (OA&M) support for the RPC. In addition, it provides the time slot cross connect switch for communications between the E1IFs and the RPIFs. Figure 2-3 represents the ECNT functions.

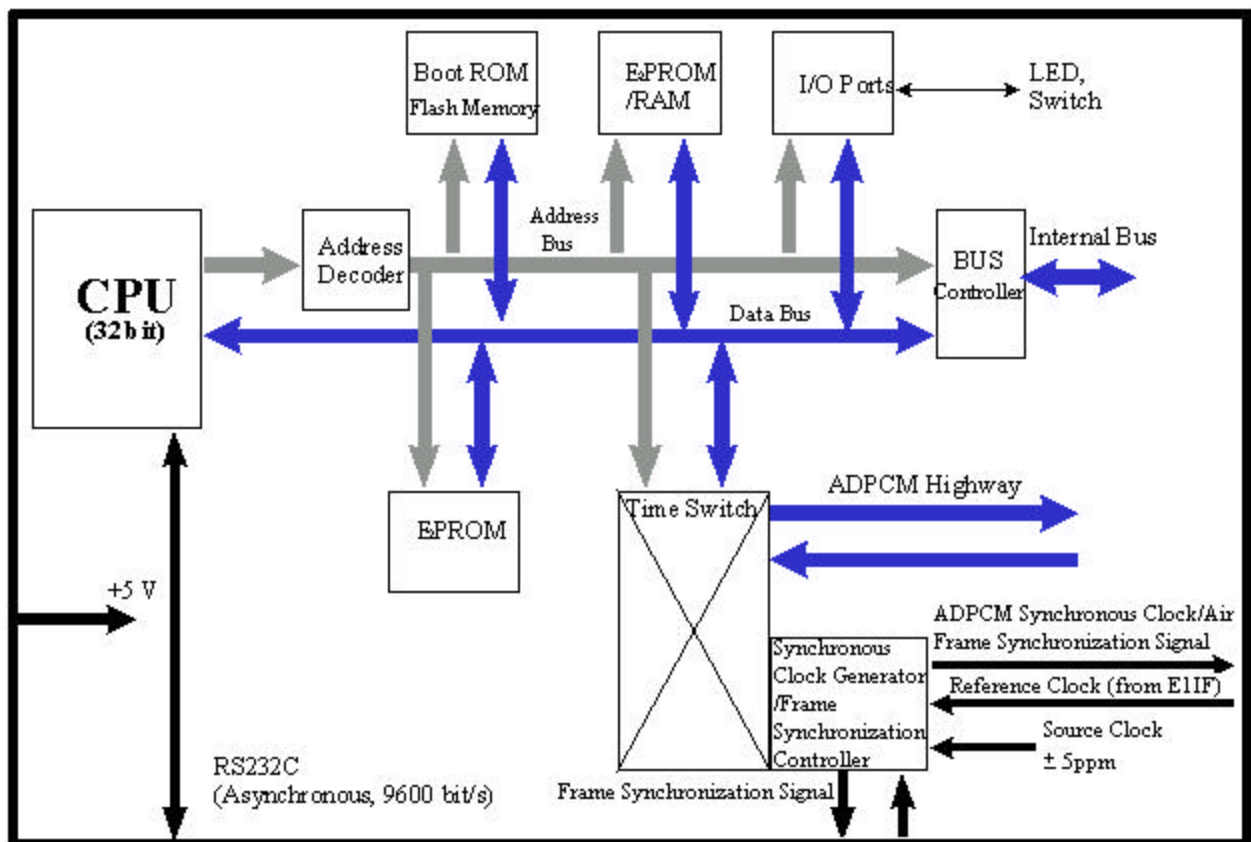

Figure 2-3: ECNT Block Diagram

The ECNT module performs the clock synchronization by generating a synchronized clock from the extracted clock signal from the E1 line on the E1 interface card and delivers it to the RP lines on the RP interface cards.

The RPC uses a control bus via the ADPCM highway on the mother board to synchronize the system. The Control Bus is an 8-bit mixed bus address with data and First-in First-out (FIFO) type bus. The main CPU on the ECNT card, the local CPUs on E1 Interface cards and the RP-interface cards are all connected by this bus. The main CPU on the ECNT card controls the bus.

Figure 2-4 shows the module's physical configuration and describes the function of the LEDs and the reset switch.

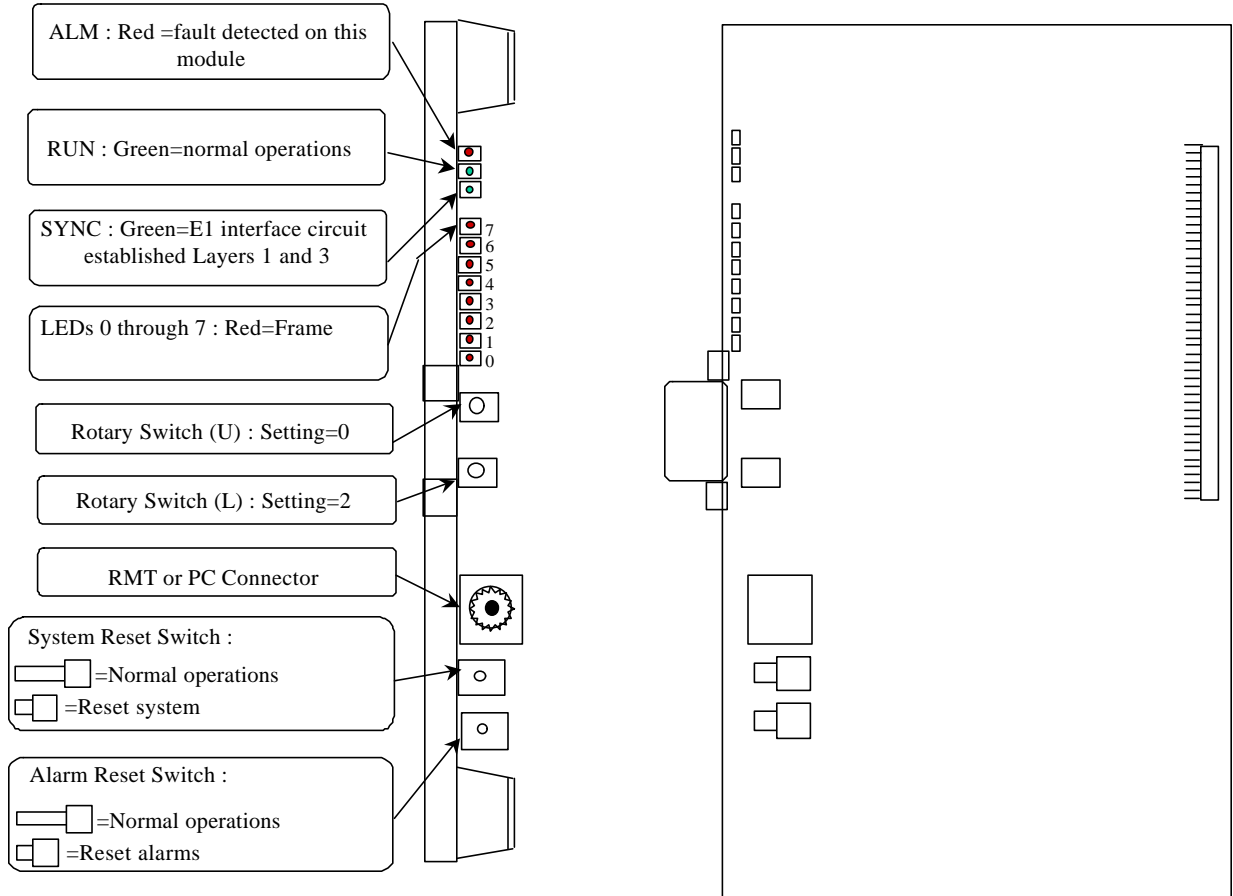

Figure 2-4: ECNT Module Layout

### 2.1.2.2 E1 Interface Module

The RPC connects to the COT through a 2.048 Mbps E1 Interface that carries all the control and voice channels, that is, PCM encoded voice or voice band data, between the COT and the RPC. The E1 Interface (E1IF) module communicates externally with the COT through 1 G.703 E1 interface and uses Q.931 non-facility associated signaling protocol.

Transmission between the RPC and RP is based on a proprietary, echo-canceled transmission standard, which is similar to the recognized G.961 ISDN standard. The E1IF provides the speech coding conversion between A-law PCM from the COT and Adaptive Differential Pulse Code Modulation (ADPCM), which is ITU-

Rec.726 compliant, from the RP. It supports 32 kbps channel signaling for encoded voice and voice band data calls.

In addition, the E1IF communicates internally with the Radio Port Interface (RPIF) module for interfacing RPs through the backplane busses and the switch in the ECNT module.

The E1IF module is an E1 module (E1M) that provides 4 E1 connections to the E1 network. The E1 module has the following functions:

- Originates/terminates 4 G.703/G.704 2.048 Mbps E1 interface
- Provides 75 ohm unbalanced interface
- Provides LEDs for module and port status and alarms
- Performs CRC-4 on the E1 line according to G.706
- Monitors performance of each E1 line
- Detects errors and alarms on the E1 lines.

Figure 2-5 depicts the processing of the E1IF module

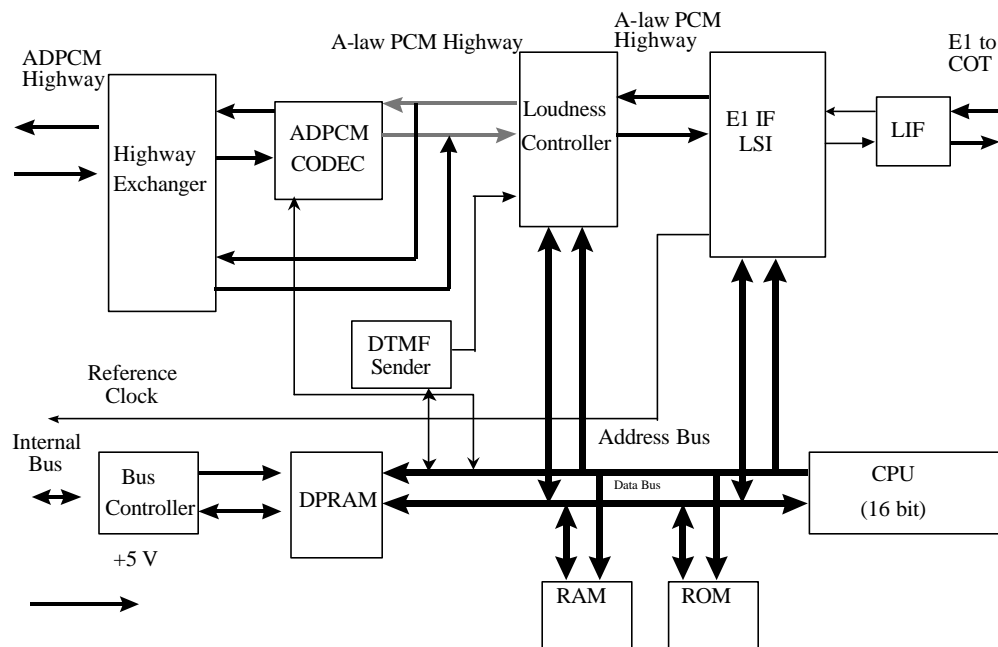

**Figure 2-5: E1 Interface (E1IF) Module Block Diagram**

Figure 2-6 shows the module's physical configuration and describes the function of the LEDs and the reset switch.



**Figure 2-6: E1IF Module Layout**

### 2.1.2.3 Radio Port Interface Module

Each RPC controls and feeds a maximum of 32 RPs. The RPC connects to the RPs through a 2-wire proprietary interface. Line power feeding from the RPC provides a power source of 116V DC to the RPs.

The RPC controls the RPs via 8 RPIF modules. Each RPIF module provides an ISDN Basic Rate interface to 4 RPs. The RP is extended from the RPC to a maximum distance of 5.0km using a pair of  $\phi 0.5$  wires and approximately 3.5 km using a pair of  $\phi 0.4$  wires.

The Radio Port Interface (RPIF) module communicates externally with four RPs through ISDN Basic Rate Interfaces (BRI). In addition, it communicates

internally with the E11F through the backplane busses and the switch in the ECNT module. Refer to Figure 2-7 for a block diagram of the RPIF module's processing.

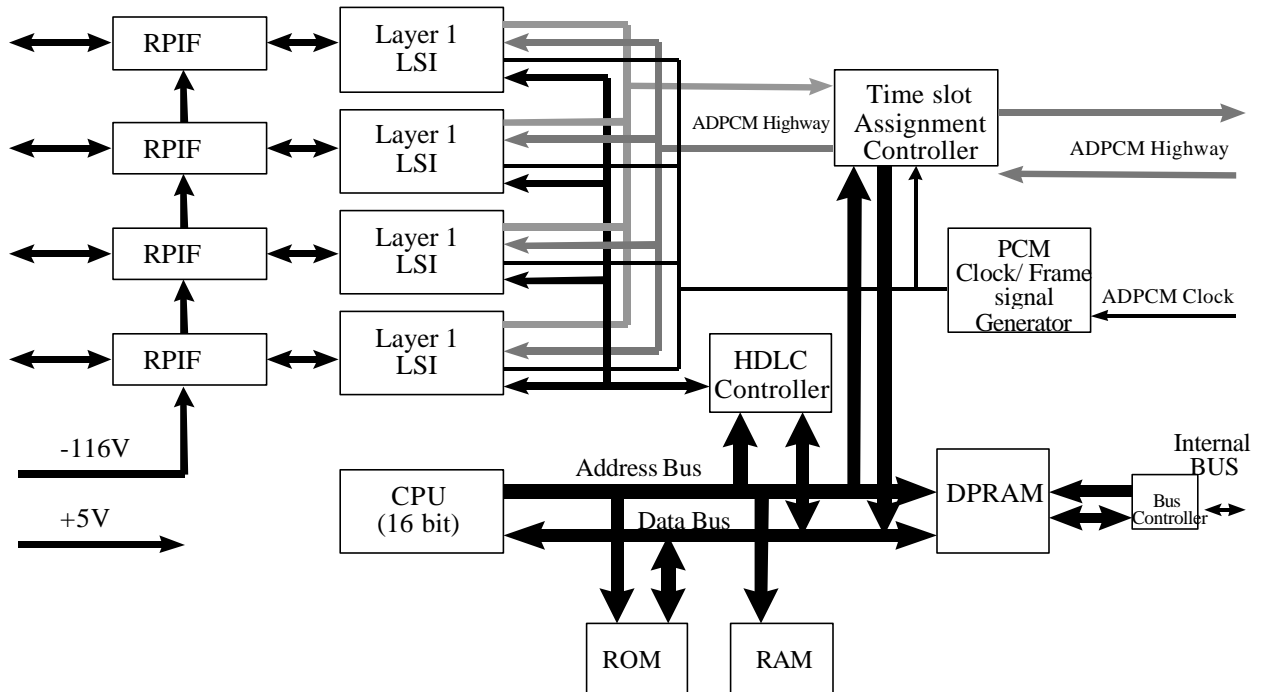

**Figure 2-7: RPIF Module Block Diagram**

Figure 2-8 shows the module's physical configuration and describes the function of the LEDs and the reset switch.

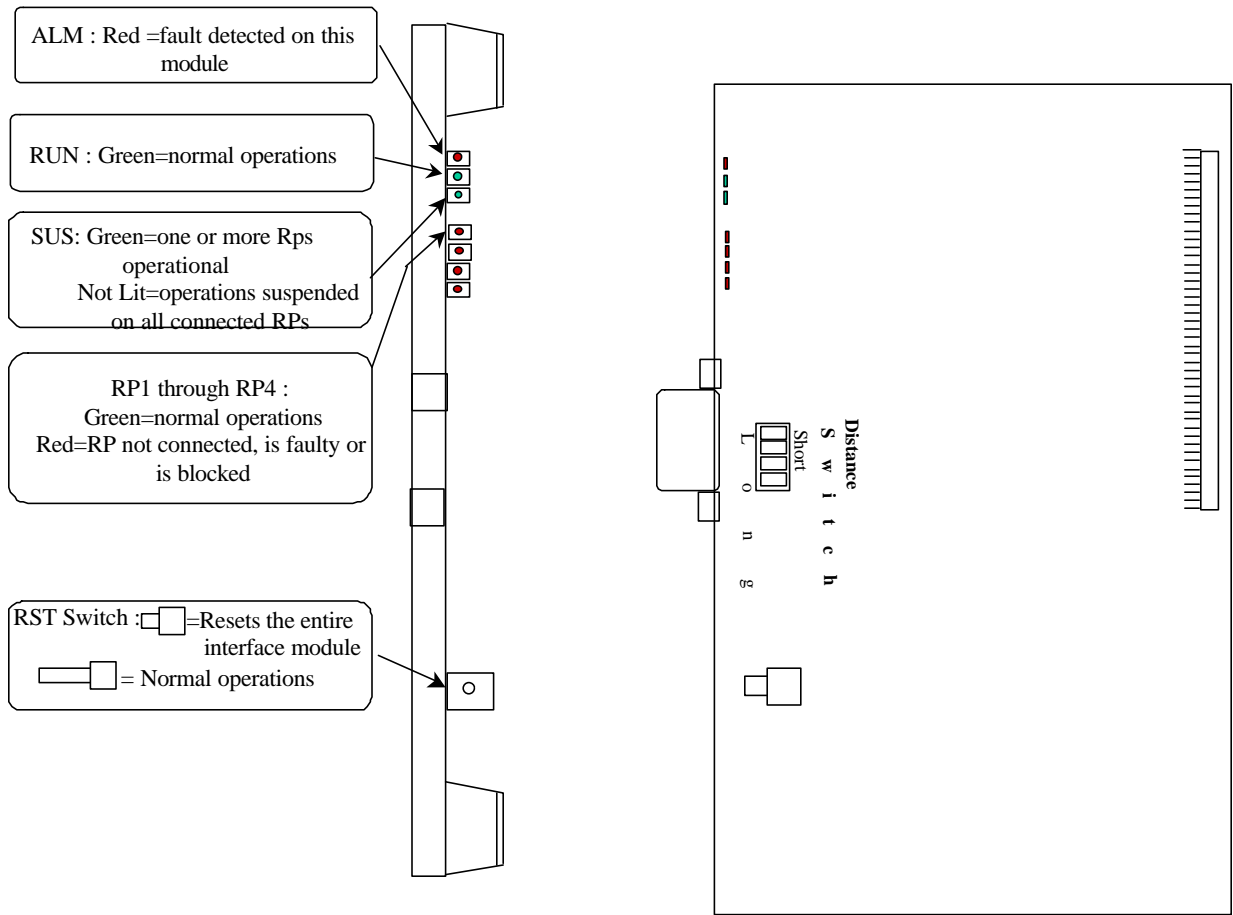
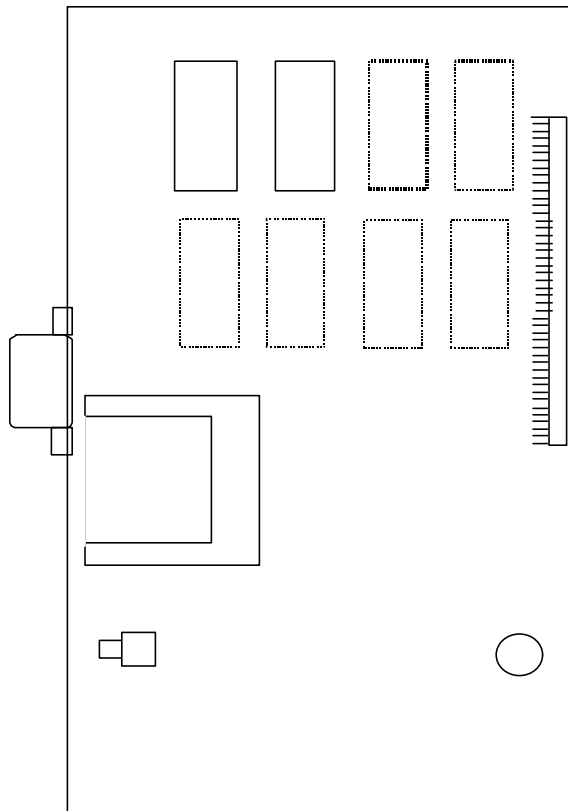

Figure 2-8: RPIF Module Layout

### 2.1.2.4 Application Software Loading Module

The Application Software Loading (APL) Module facilitates the downloading of software in the event there is a problem in loading software. It permits the upgrading of the ECNT module firmware. In addition, any software upgrades can be downloaded remotely from a PC to an RPC. The APL module is installed only when the software or firmware needs to be upgraded or downloaded. It is not intended to remain in the system during the normal operations.

Figure 2-9 demonstrates the module's physical configuration:



**Figure 2-9: Application Module Layout**

### 2.1.2.5 ADPCM Highway

The ADPCM (Adaptive Differential Pulse Code Modulation) highway is the synchronous time multiplex digital voice/data path, and consists of up-stream and down-stream for Time Switch on the ECNT card. Time Switch and the digital voice and data paths on the E1IF cards and the RPIF cards are connected by the ADPCM highway.

There are 8 ADPCM highways in an RPC. Half of them are assigned for E1IF cards, and the rest are assigned for RPIF cards. The bit rate of an ADPCM highway is 2048 kbps, and the frame repetition rate is 8 kHz.

## 2.2 System Construction

An RPC has two types of installation scenarios:

- Rack mount
- Stand-alone

Figure 2-10 shows the physical configuration of the rack mount type RPC.

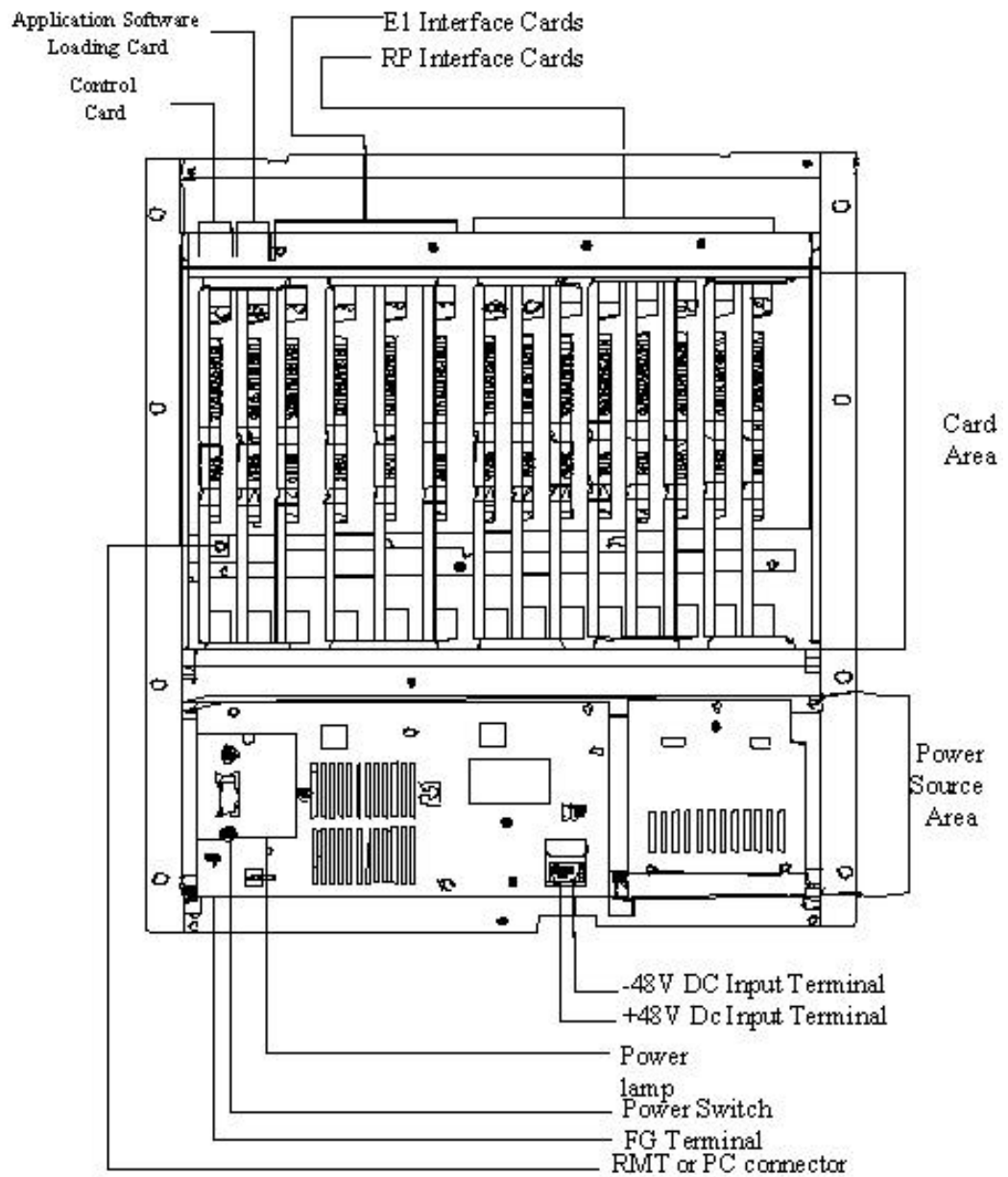

**Figure 2-10: Layout of Rack Mount Type RPC**

The RPC is 532.6mm high, 482.6mm wide, and 265mm deep.



## 2.3 Installation

This section provides the instructions for installing an RPC. The flow chart in Figure 2-11 depicts the steps involved in the installation.

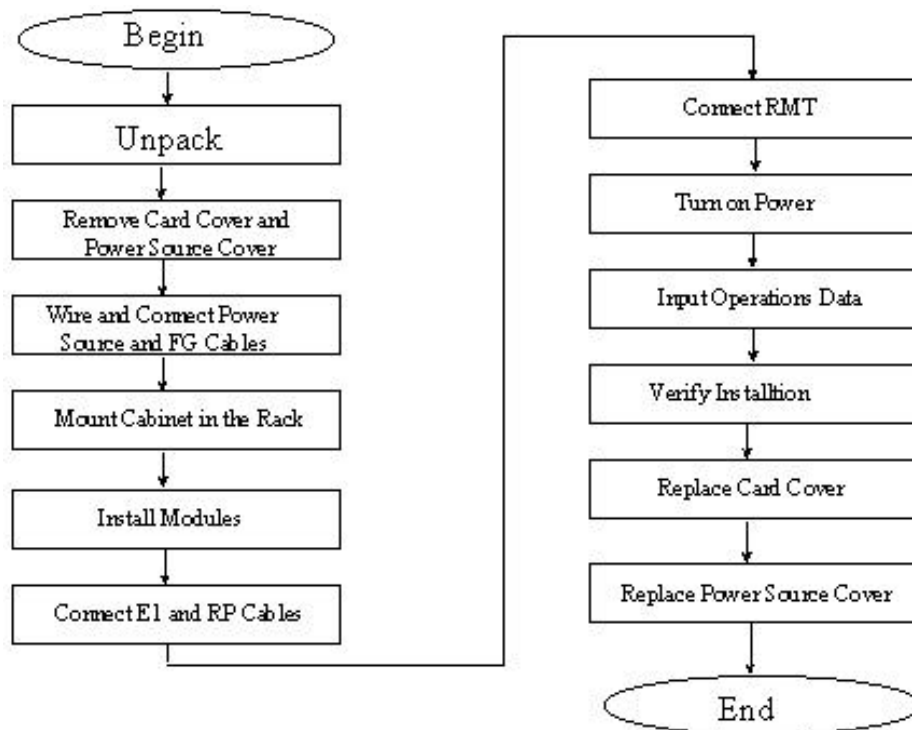

Figure 2-11: RPC Installation Flow Chart

### 2.3.1 Before Beginning

To ensure that the RPC installation goes smoothly, it is necessary to do adequate planning prior to the installation, including:

- Location of the RPC
- Tools required
- Number of people needed to complete an installation.

### 2.3.2 RPC Site Selection

The RPC needs an environment that is relatively dust and moisture free. Make sure the location meets the following requirements:

- Not in direct sunlight
- Free from extremes of heat, cold, and moisture
- 0° to 40° C ambient temperature

### **2.3.3 Tools Required**

Be sure to have the following necessary tools:

- Screwdrivers
- Soldering iron and solder
- Tie bands for cabling

### **2.3.4 Installation Instructions**

Follow the steps below to install the RPC:

1. Carefully unpack the RPC and the accessories and make sure that they are in good condition. Accessories include 2 connectors for the RP connection cables. Refer to Figure 2-12 for unpacking.

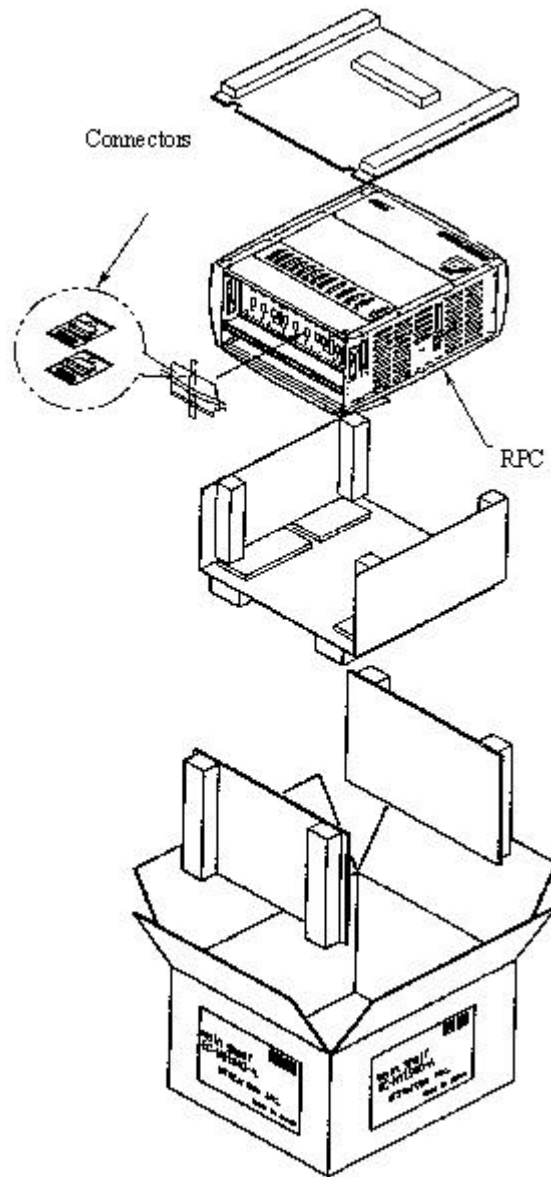

**Figure 2-12: Unpacking the RPC and Accessories**

2. Before installing the RPC in the rack, make sure to remove the card cover and the power source cover.



**CAUTION:** *Do not take a photo with a flash once the card cover has been removed. RPC may not operate.*

3. Loosen the thumbscrews. Tilt open the cover and slide it out as shown in Figure 2-13.



**CAUTION:** *The card cover cannot hold itself when opened. Be sure to detach it from the cabinet.*

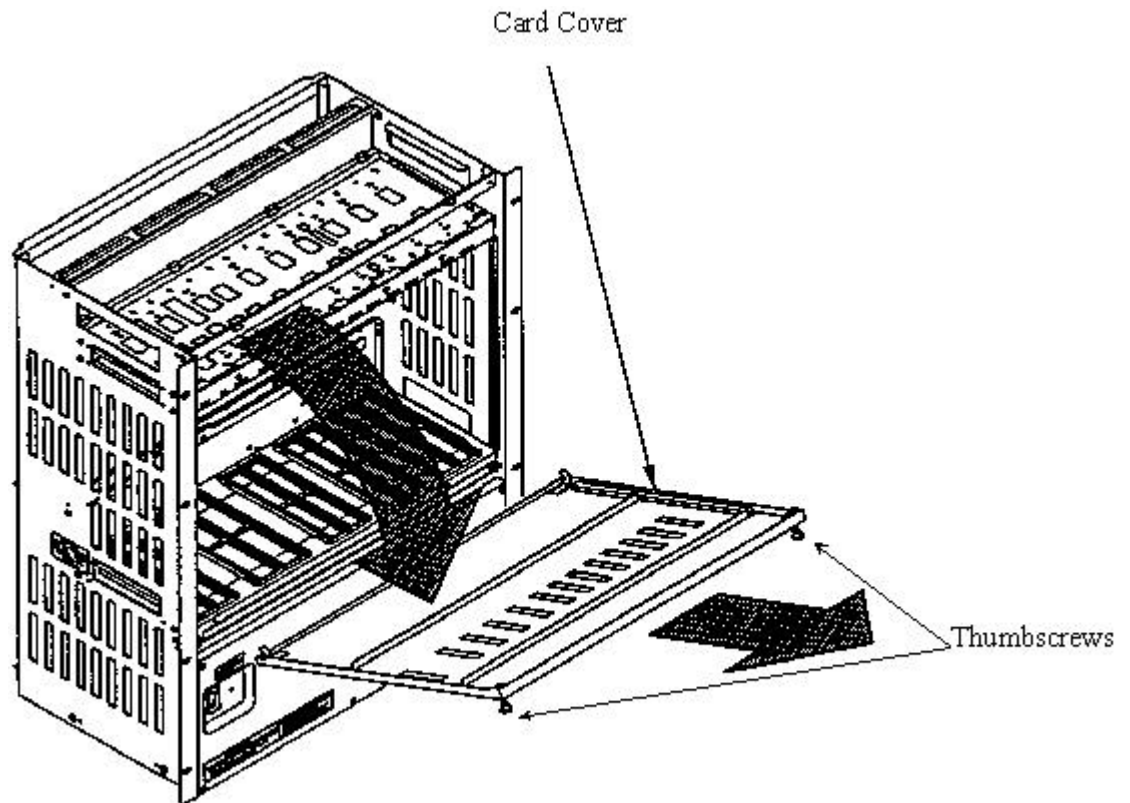

**Figure 2-13: Removal of the Card Cover**

4. Remove the 5 M3 screws in the power source cover and remove it, as illustrated in Figure 2-14.

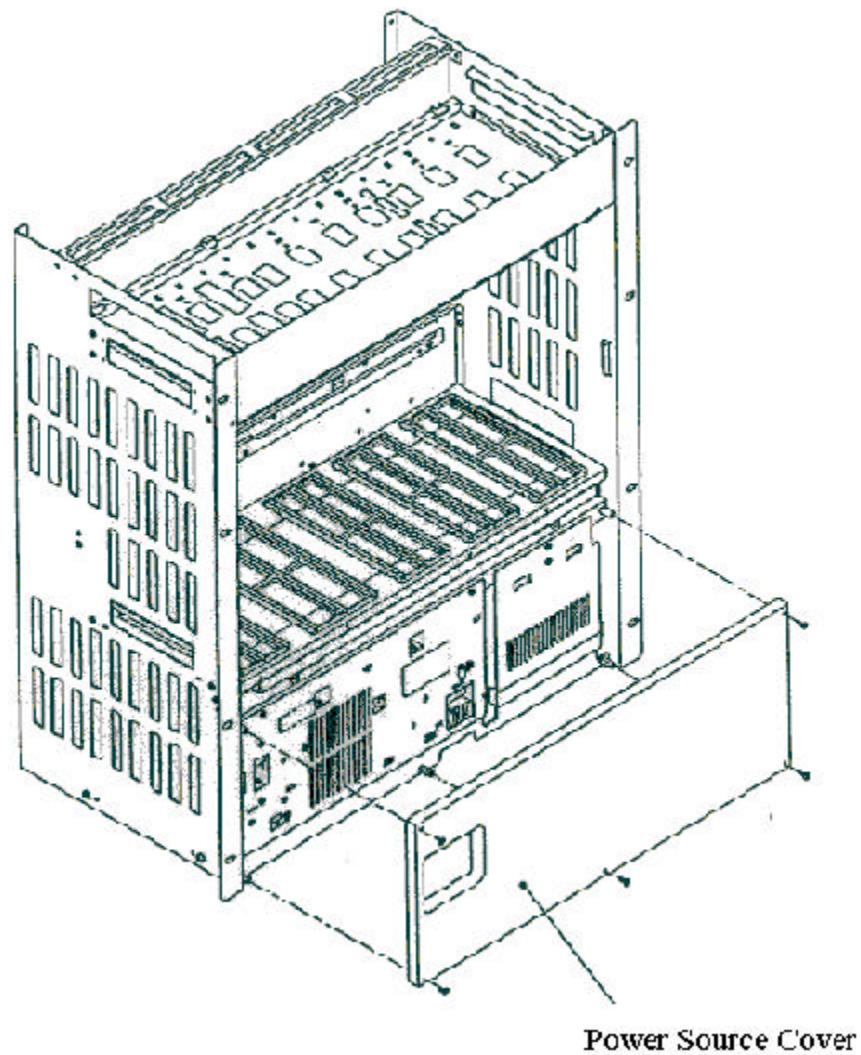

**Figure 2-14: Removal of the Power Source Cover**



*CAUTION: When inserting and removing each component, make sure to follow the proper electro-static discharge (ESD) procedures.*

5. Connect and wire the power source and FG cables, as shown in the figure below.

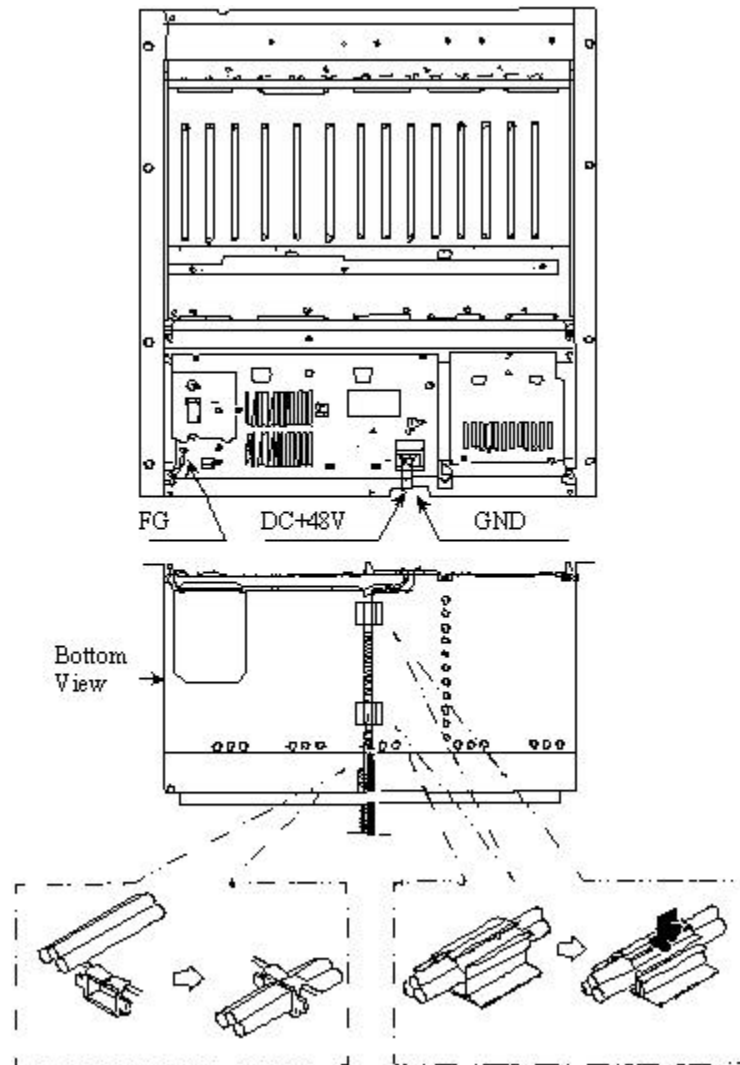
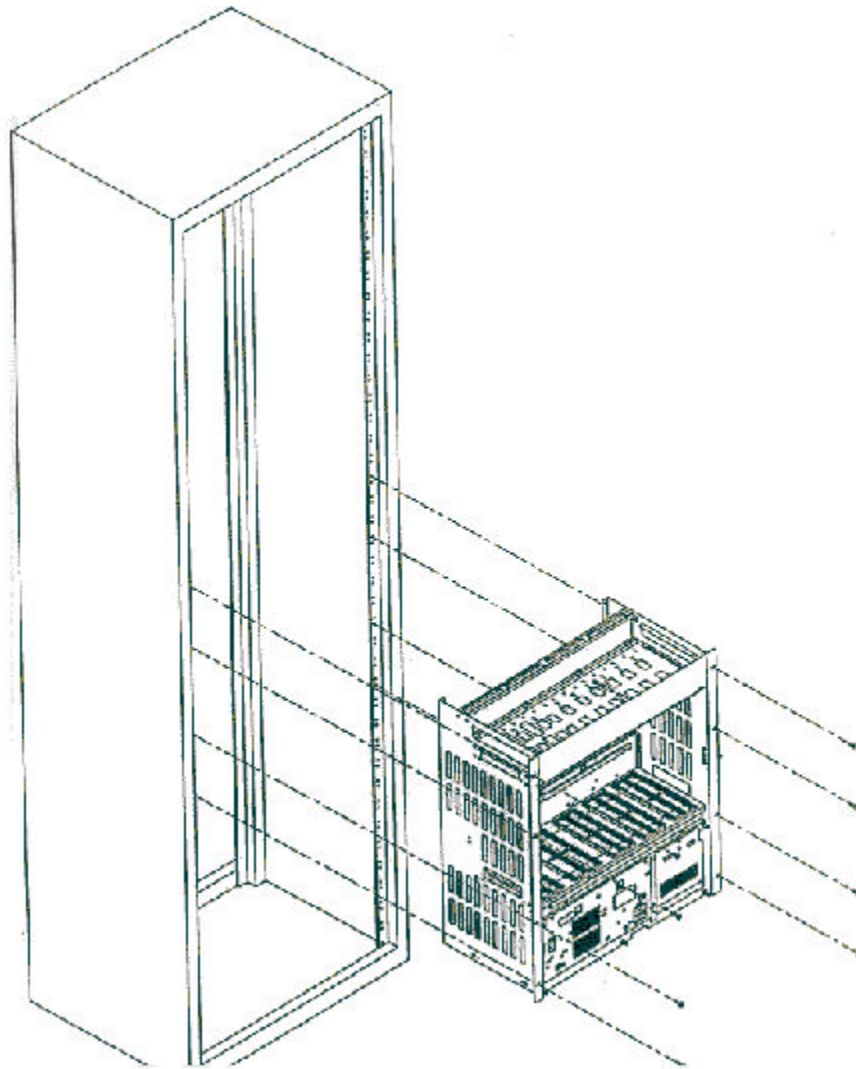

Figure 2-15: Power and FG Cable Connectors

6. Insert the RPC in the rack and fasten to the rack with 8 screws as indicated in Figure 2-16.



**CAUTION:** Make sure the RPC is firmly mounted in the rack. Serious injury could occur if the RPC fell out of the rack.



**Figure 2-16: Mounting the RPC in the Rack**

7. After installing the RPC in the rack, affix the wiring as indication in Figure 2-17. Redirect the support according to the direction of the wiring, as shown in Figure 2-17.

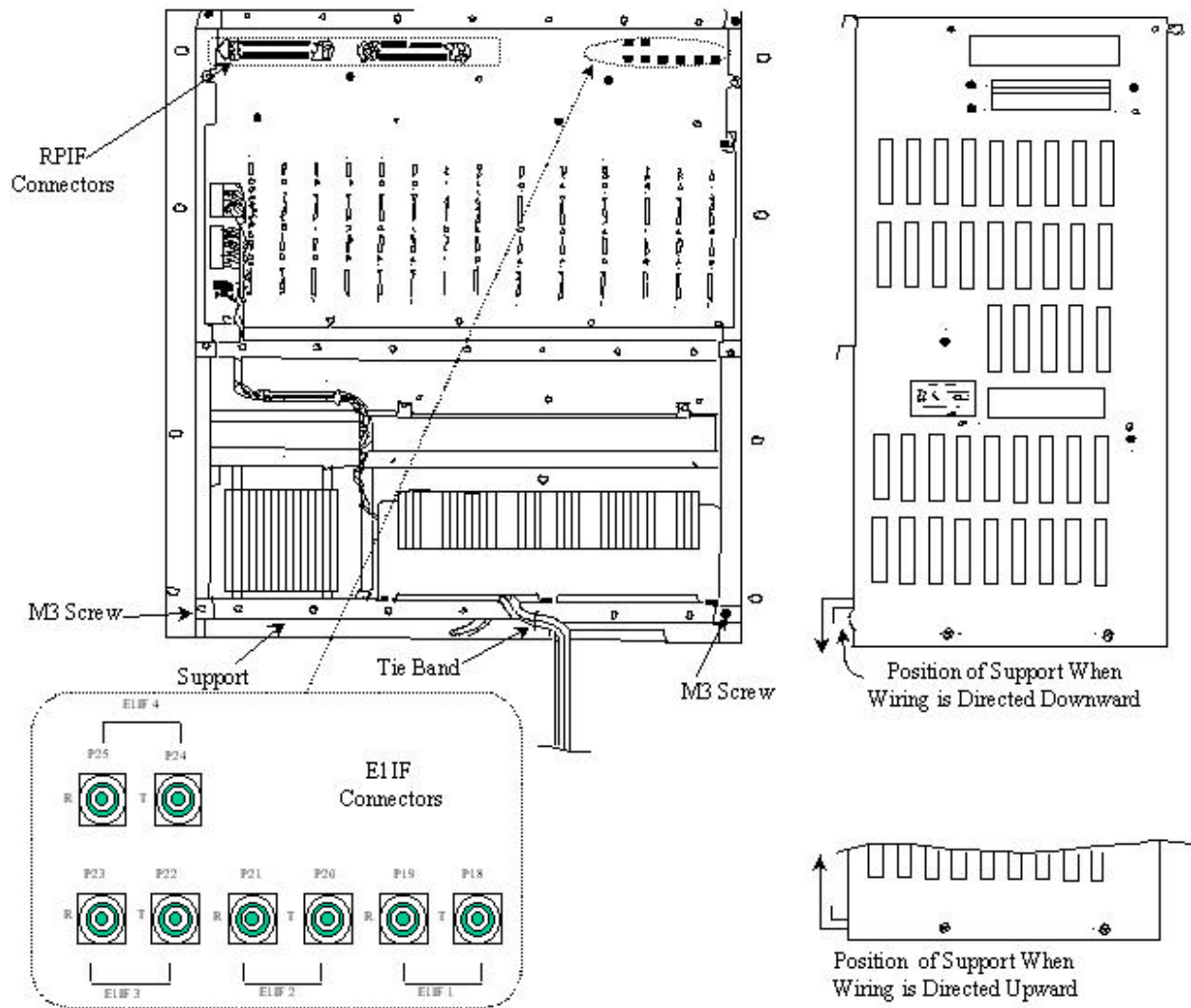

Figure 2-17: Wiring – Back of RPC

8. Connect the coaxial cable with an SMB coaxial cable plug having an impedance of 75 ohms into the E1IF connectors on the back of the RPC, as shown in Figure 2-17
9. Connect the cable with a Champ plug to the RPIF connector on the back of the RPC. Refer to Figure 2-17. Table 2-1 provides the maximum cable lengths between the RPC and the RP for 2 different wire gauges. Refer to *Appendix A* for the description of the 2 Champ RPIF connector pin assignments.



Wire Guage	Maximum Cable Length
φ0.4 m	3.5Km
φ0.5 m	5.0Km

**Table 2-1: Maximum RP Cable Length**



NOTE: Be sure to use a twisted pair cable or a 2 pair twisted cable. Avoid any 2 pair twisted cable splits before connecting cables.

10. When the RP and E1 cables are connected, attach the cabling to the supports with tie bands. Refer to Figure 2-18.



NOTE: Tie Bands are to be prepared on-site.

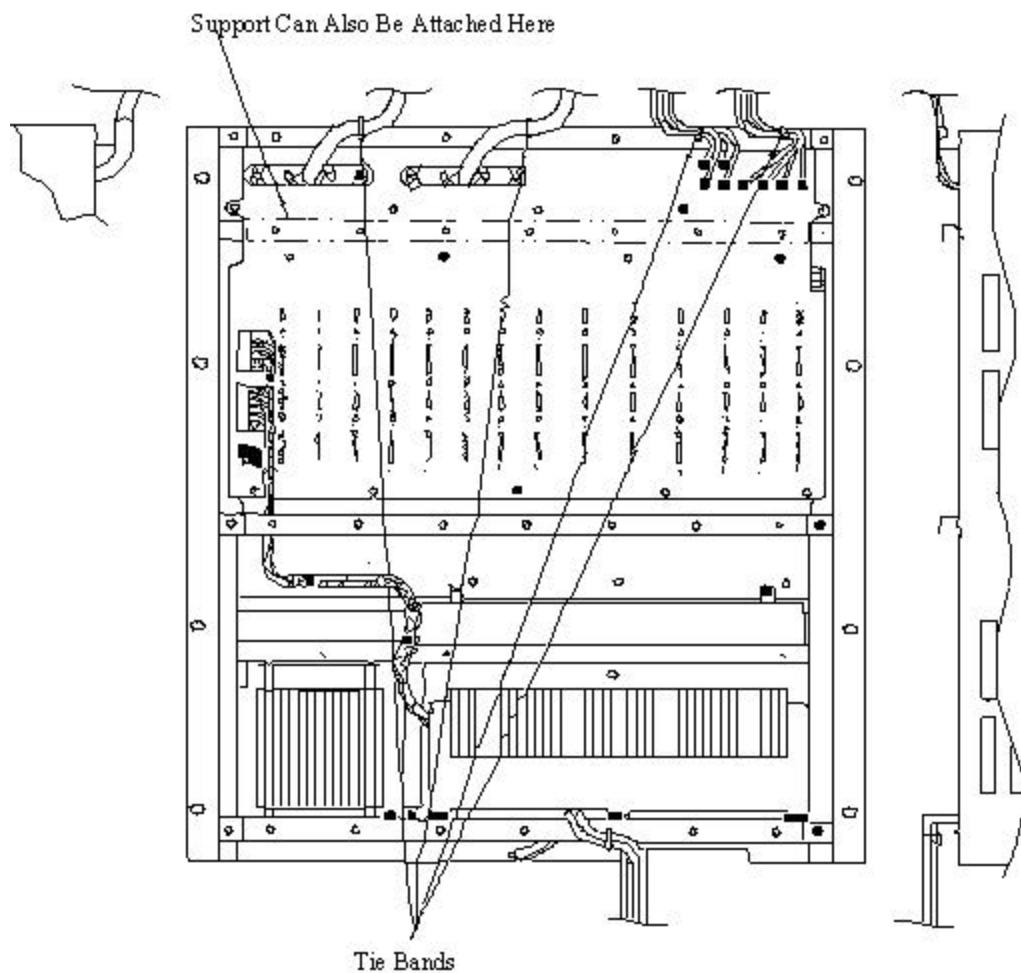
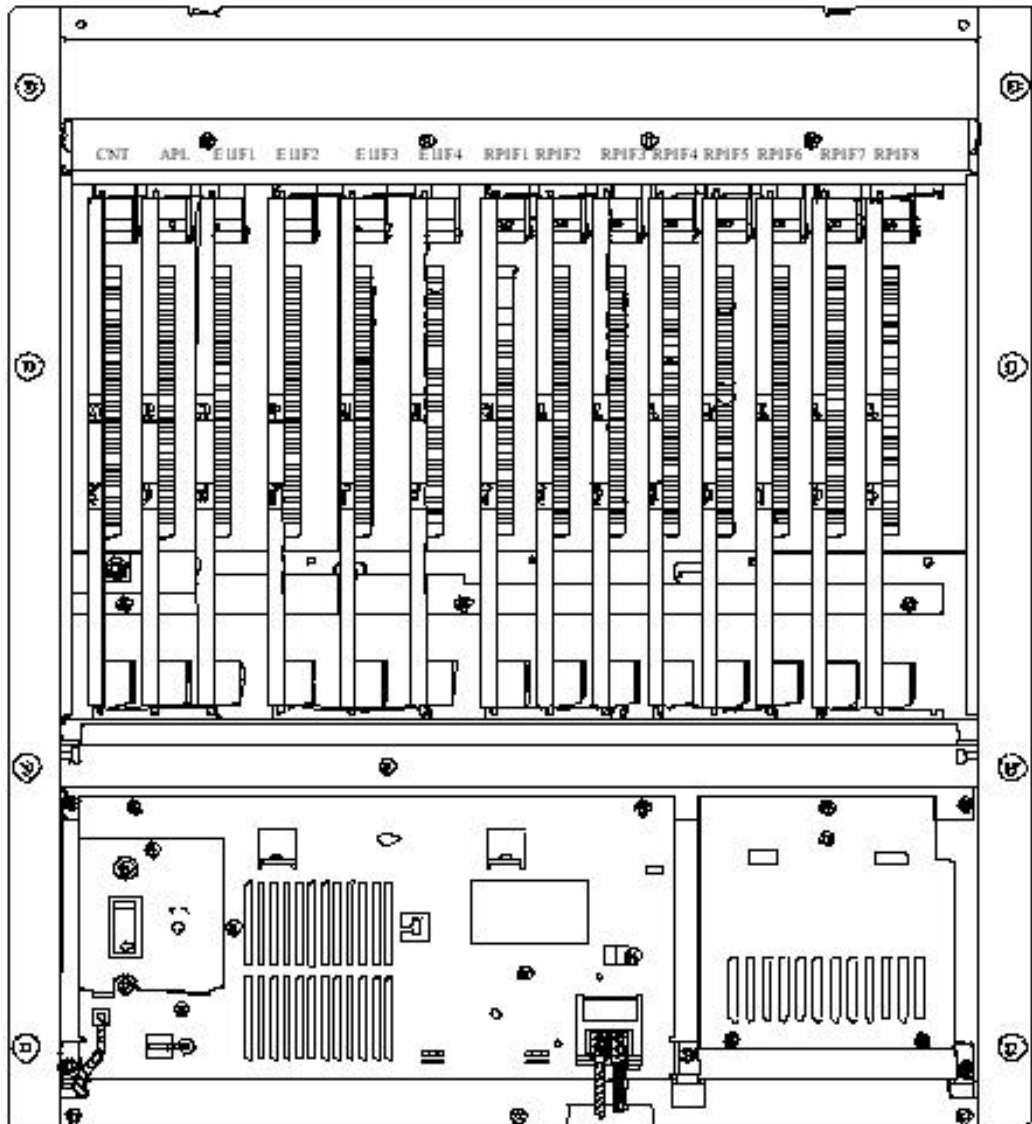

**Figure 2-18: Cabling Example**

11. Install the modules in the RPC slots according to the labels on the cabinet.  
Refer to Figure 2-19 for the slot assignment.



*NOTE: The APL module is installed only when the software upgrades are unsuccessful without it. It is not intended to remain in the system during normal operations.*



**Figure 2-19: RPC Slot Assignment**

12. Make sure that the rotary switches on the ECNT module are correctly set before applying power. The correct switch settings are shown in Table 2-2.

Switch Name	Setting
Rotary Switch (U):S4	0
Rotary Switch (L):S5	2

**Table 2-2: Rotary Switch Settings**

- Slide the card into the RPC shelf using the upper and lower slot guides. When properly seated, the lower edge of the card is recessed from the outer edge of the lower slot guide. And the upper edge of the card is flush with the outer edge of the upper card guide. Refer to Figure 2-20.

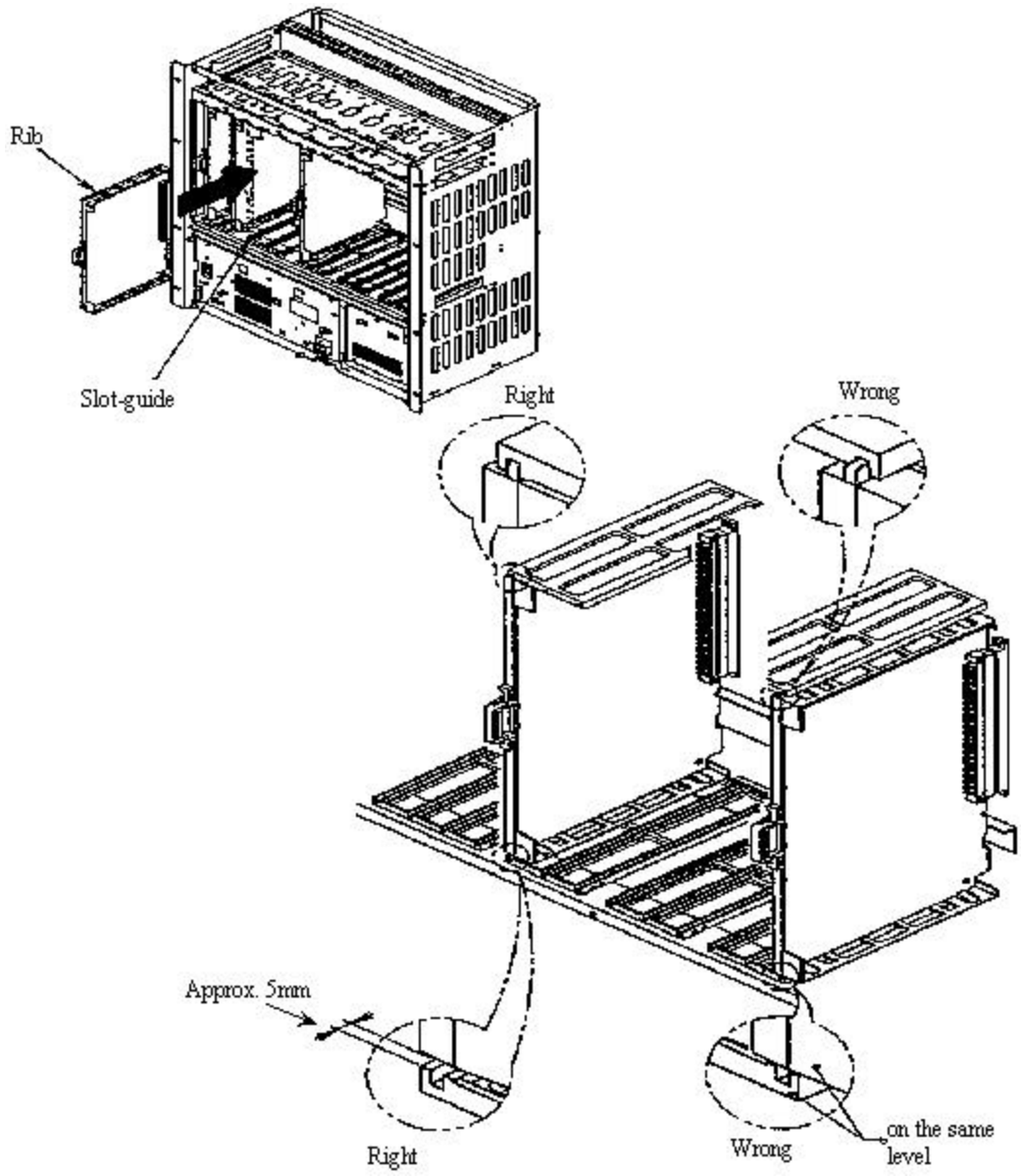

**Figure 2-20: Card Installation**

14. Connect the RMT or PC to the connector on the ECNT module. See Figure 2-21.

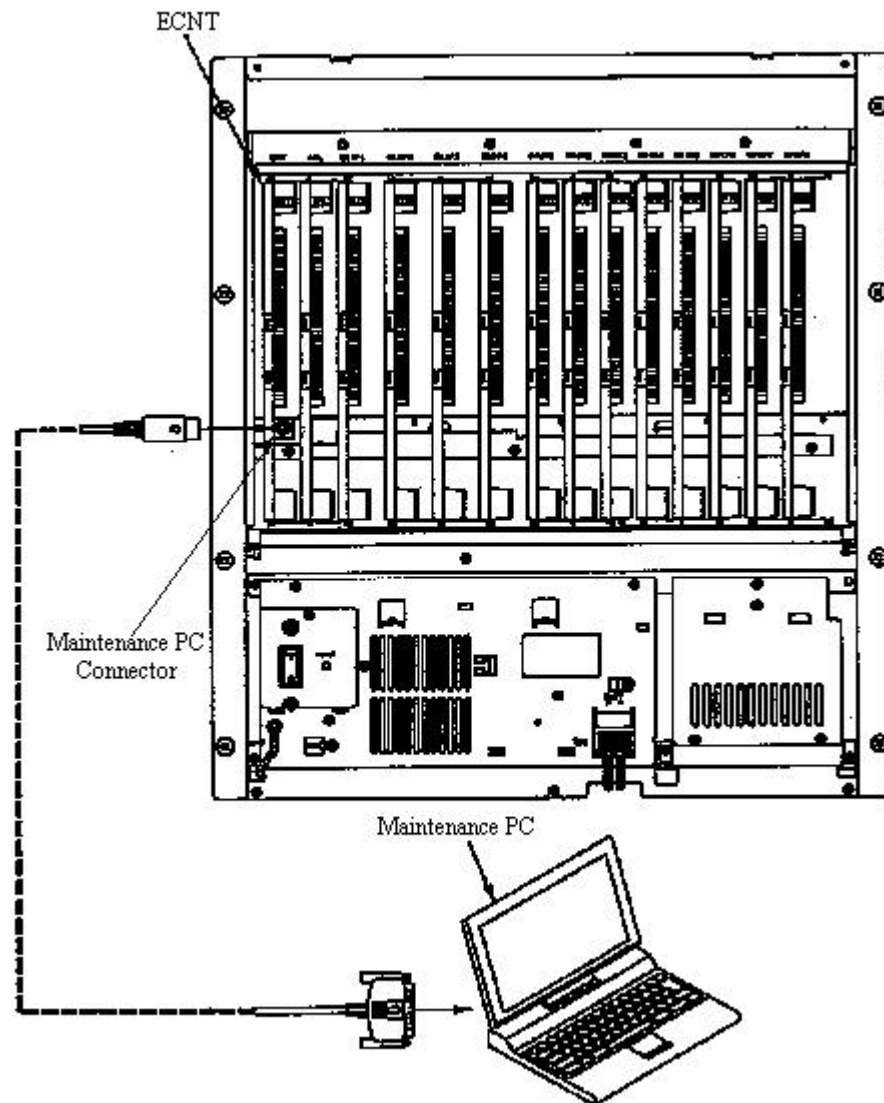

**Figure 2-21: Maintenance Terminal or PC Connection**



*NOTE: RPC maintenance and configuration can also be made through the network management system via the COT which is connected to the RPC.*

15. Load operation data.

16. Replace the power source cover on the front of the RPC and secure it with screws as shown in Figure 2-22.

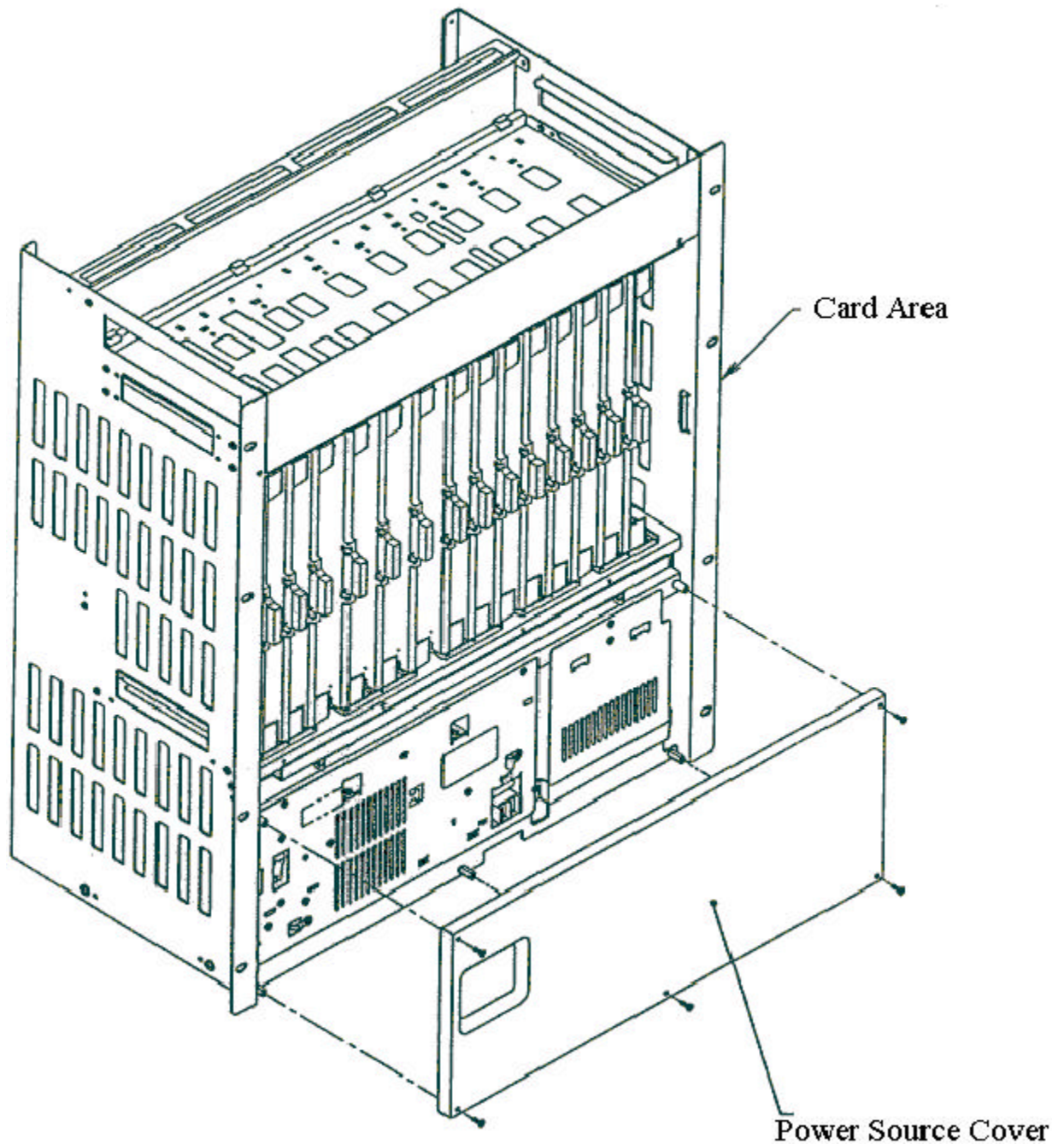

**Figure 2-22: Replacement of Power Source Cover**

17. Replace the card cover. Make certain the hinge pins are properly aligned with the hinge. Tighten the thumbscrews.

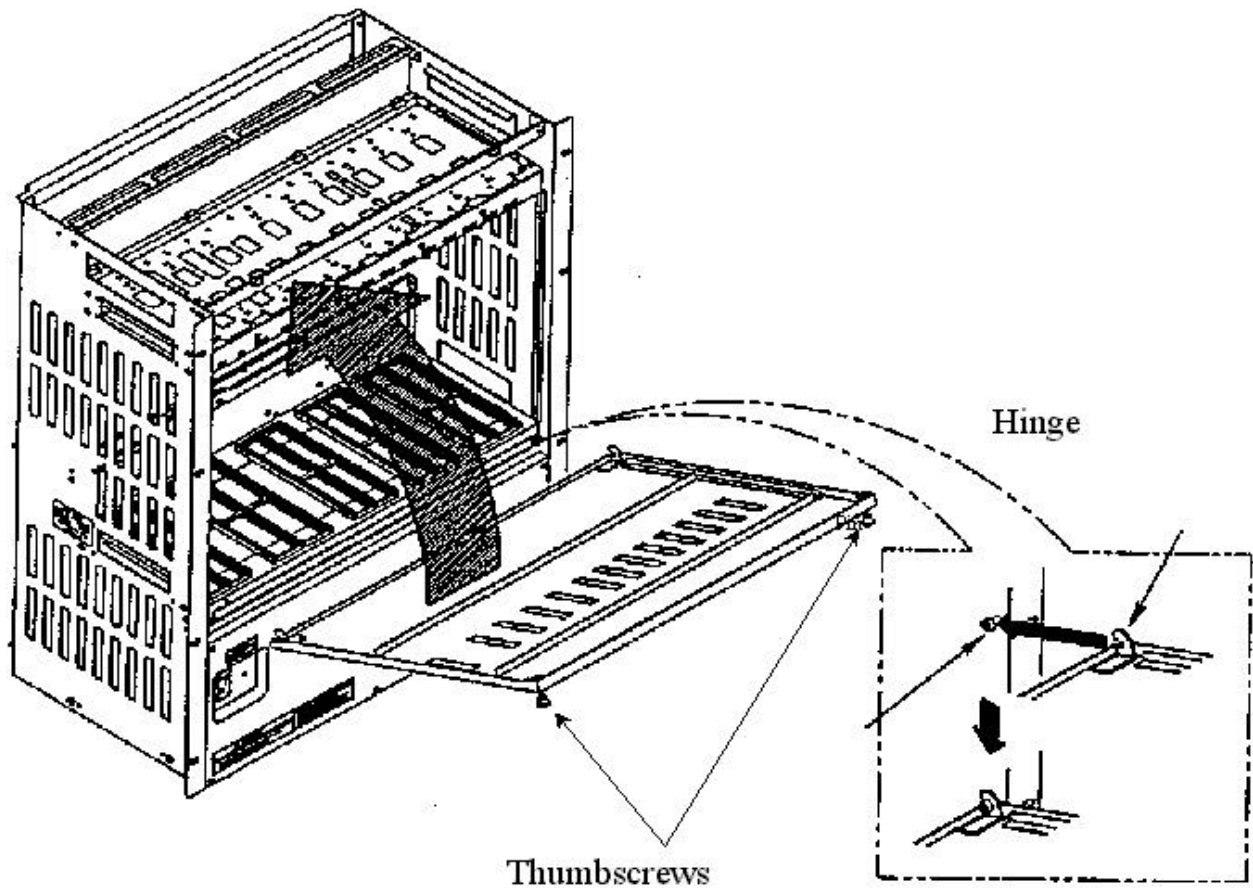
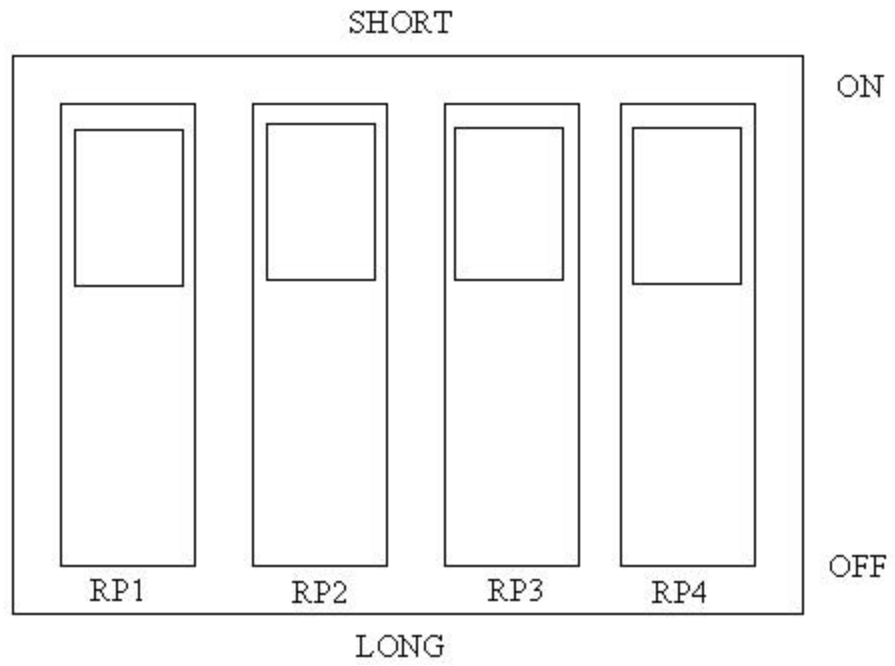

**Figure 2-23: Replacement of the Card Cover**

18. This concludes the RPC installation.
19. When the RPs have been installed and connected to the RP Interface cards, measure the loop resistance of the cable. Then set the Distance Switch on the RP Interface card based on the loop resistance value. Refer to the table and figure below. The factory setting is Short.

Setting	Loop Resistance
Long	150Ω or more
Short	Less than 150Ω

**Table 2-3: Distance Switch Settings**



**Figure 2-24: Distance Switch**





---

# RP Installation

# 3

---

## 3.1 General Description

The Radio Port (RP) is the radio equipment base station that relays the communication from the user side to the operator/network side or vice versa. A standard installation for RP applications places several RPs in a common service area. However, the number of RPs and their distribution deployment depend on the following factors:

- Topography of the service area
- Subscriber distribution in the service area
- Desired Grade of Service and traffic load.

There are two types of RPs:

- Outdoor - is small in size and is encased in a weather-proof cabinet. This gives it the potential for various mounting scenarios - installed on the dedicated poles, buildings, or street lamp poles.
- Indoor - is also small in size and can be installed in public and semi-public locations like an office building, a shopping mall, or an underground parking lot.

The power for the RP is fed from the RPC and a synchronous clock is delivered from the RPC. The radio link between the RP and the FSU, or the RP and the PS is based on RCR-STD 28 Ver.2 PHS technology, which defines frequency bands, protocol, and so on. Both the indoor and the outdoor RPs have a 2 branch built-in antenna.

The architecture of the WLL system is illustrated in Figure 3-1, which is followed by a block diagram of the RP.

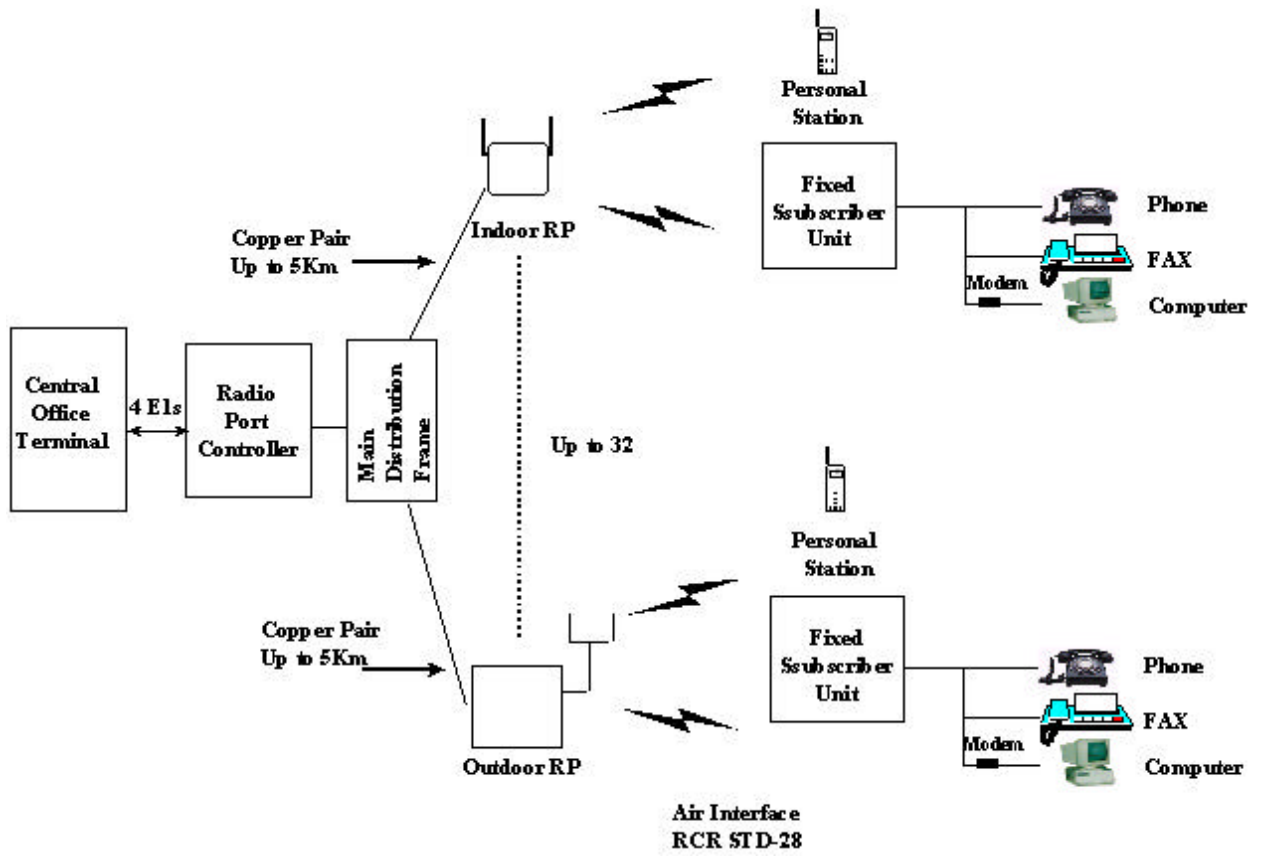

Figure 3-1: RP in the WLL System

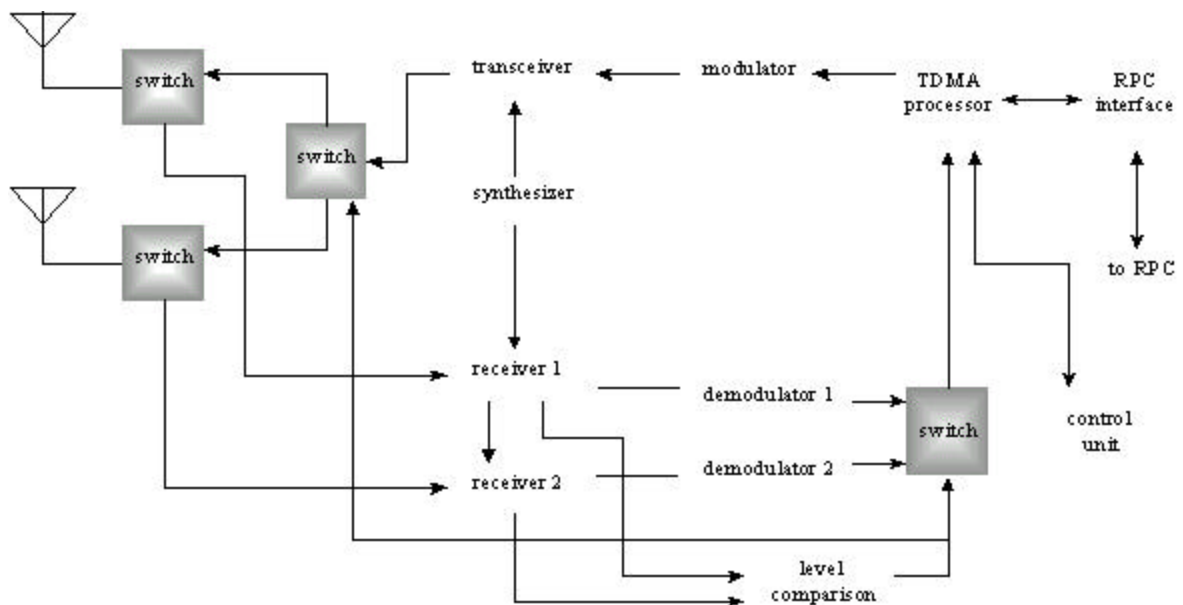

Figure 3-2: Radio Port Block Diagram

### 3.1.1 Traffic Handling

PHS applies Time Division Multiplex Access (TDMA) and Time Division Duplex (TDD) techniques. Each individual radio link between the RP and the FSU/PS is assigned 1 time slot for a control channel (C-ch) and 3 slots for traffic channels (T-chs).

In the case of a single RP, there are 4 time slots installed for radio links. One slot is the control channel for signaling and the other three are the traffic channels. The number of accommodated subscribers in that RP covering the zone calculated according to the erlang theory is as follows:

- Erlang per zone (3 T-chs, GOS=5%) = 0.899 erlang
- Subscribers (FSUs or PSs)  $(0.899 \div .08) = 11$  subscribers

Group Control maximizes the number of channels available for traffic by allowing one control channel to control up to 8 RPs (up to 31 traffic channels), which is an efficient application for high traffic areas. One master RP can control a maximum of 7 RPs in the same area. The master RP has one control channel, and all the other channels are assigned for traffic, leaving 31 channels open for traffic. Figure 3-3 represents the group control configuration with 4 RPs in the group.

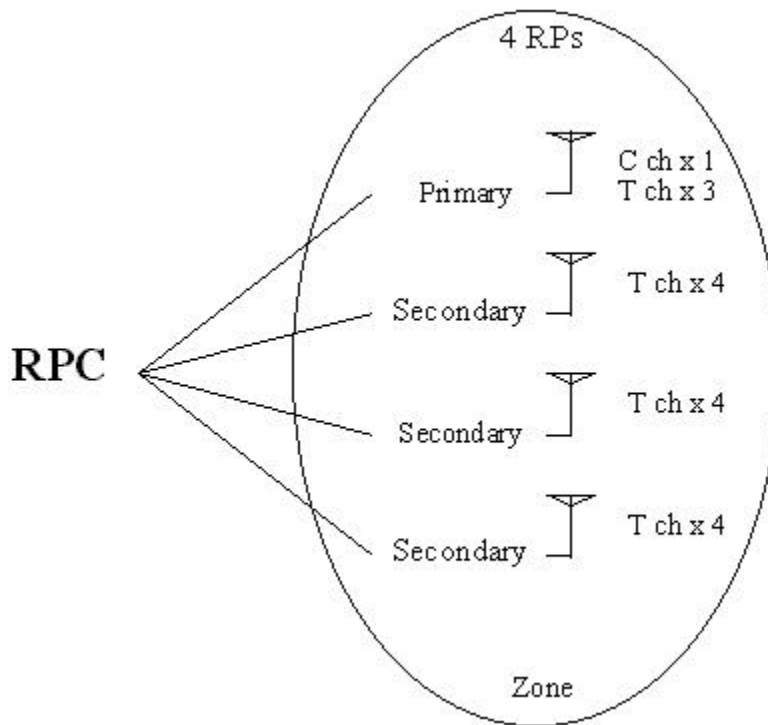

**Figure 3-3: Group Control RPs**

In the group control mode, the number of accommodated subscribers in the group control coverage zone is calculated in accordance with the erlang theory as follows (with 4 RPs in the group):

- Erlang per zone (15 T-chs, GOS=5%) = 10.663 erlang
- Subscribers (FSUs or PSs)  $(10.663 \div .08) = 132$  subscribers

The comparison for the number of accommodated subscribers between the group controlled RPs and the single RP is shown in Figure 3-4.



*NOTE: Figure 3-4 represents the group control with 4 RPs. Each group can have a maximum of 8 RPs.*

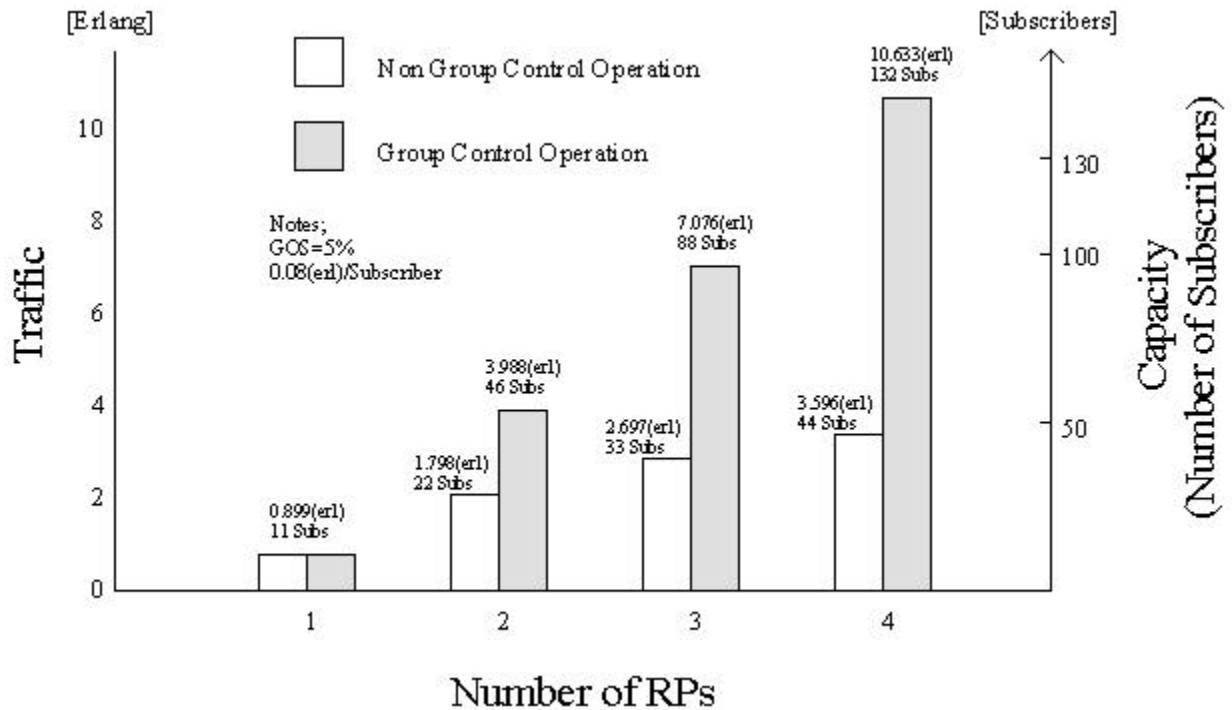

Figure 3-4: Accommodated Subscribers per RP in Group and Non-group Control

The recommended installation design for RPs is as follows:

- A zone of sparse subscribers should be covered by non-group controlled RPs.
- A zone of dense subscribers should be covered by group-controlled RPs.

The number of accommodated subscribers is the greatest when all of the RPs connected to an RPC are configured in the group control mode. In this case (with 4 RPs in each group), the number of service zones is eight (32÷4), and the maximum number of subscribers is 1,056 (132x8). Each Group Control zone supplies 15 traffic channels. Eight zones require 120 channels (15x8) provided by 4 E1 lines with 30 channels each.

### 3.1.2 Cell Overlap

Maximum service results are achieved when the RP coverage area is strategically installed in a Cell Overlap Capacity.

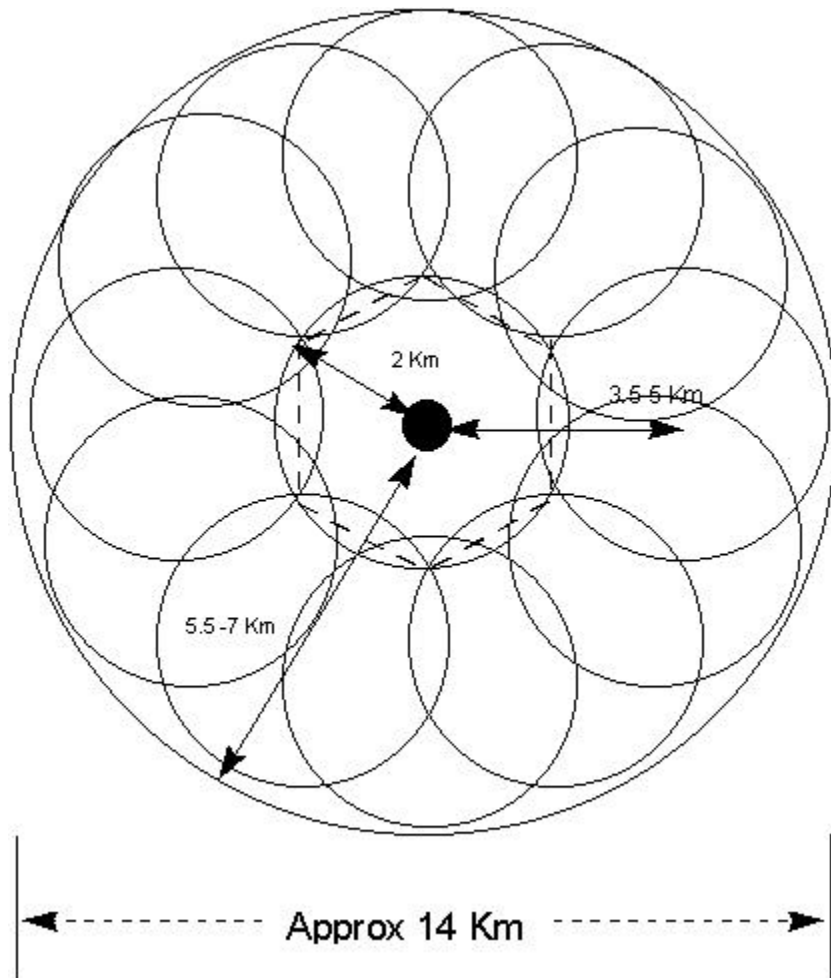
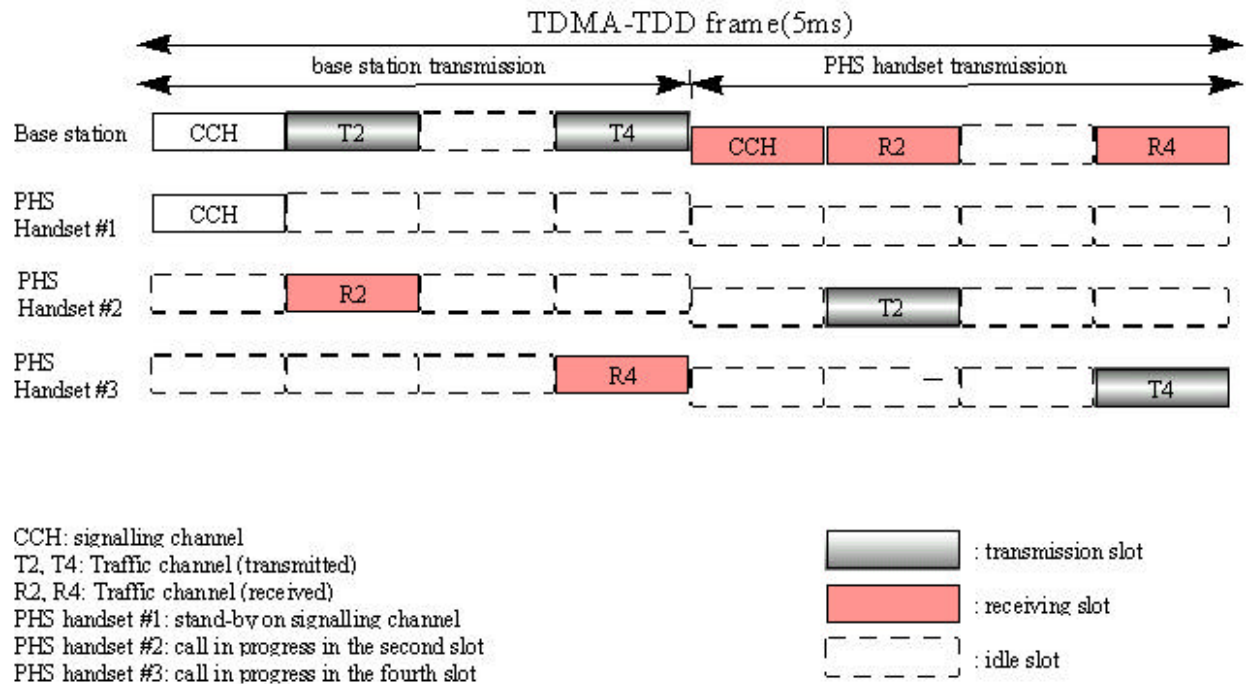

**Figure 3-5: Coverage Service Area with Cell Overlap**

The combination of Cell Overlap and Dynamic Channel Allocation increases the flexibility and the capacity of the system. Every user has access to all channels (77x4) due to the overlapping base station topology. Cell Overlap enhances the reliability and service quality. One malfunctioning base station does not affect the performance of the system. Due to the Dynamic Channel Allocation, there is no need for frequency planning, which allows the network to meet operators current demands with the option to easily expand at a later date.

### 3.1.3 Air Interface Handling

The radio interface has four-channel time division multiple access capability with time division duplexing (4-channel TDMA-TDD), which provides one control channel and three traffic channels for each cell station.



**Figure 3-6: Radio Channel Structure**

The radio frequency allocation shown in Figure 3-6 displays a typical radio channel structure when three cordless handsets are operating through a single RP. RCR STD-28 does not designate a control channel prior to the operation. Instead, it assigns the control slot to any one of the four available slots.

Traffic channels are not preassigned. Channel assignment is performed by a distributed-autonomous dynamic channel assignment scheme and is an essential function of the WLL radio system. Channel assignment for new communication is selected from the available channel resources mapped in a two-dimensional frequency-time matrix renewed by the result of checking signal strength when the call is established. The RP also completes handling of the signaling process over the radio segment.

Due to the separation of the traffic and control channels, traffic channels can be allocated in a distributed and autonomous manner by employing the switching TDMA mechanism. In order to maximize the benefit of carrier switching TDMA, the RP uses a system that synchronizes radio frames by superimposing synchronization data on the B interface. The result of this synchronization is an improved utilization of frequency as compared to asynchronous systems.

In addition, with TDMA-TDD and the diversity of the RP transmission and reception, it is not necessary to install the multiple antenna or receiver-branch diversity mechanisms in the PS handsets to improve the data communication



quality. TDMA enables the antennas to share both transmitting and receiving with the RF switches. To implement receiving diversity, the receiving units have two receiving branches, while the transmitting unit has switches for switching antennas to provide the transmission diversity.

## 3.2 System Construction

Figure 3-7 represents the RPC and RP configuration.

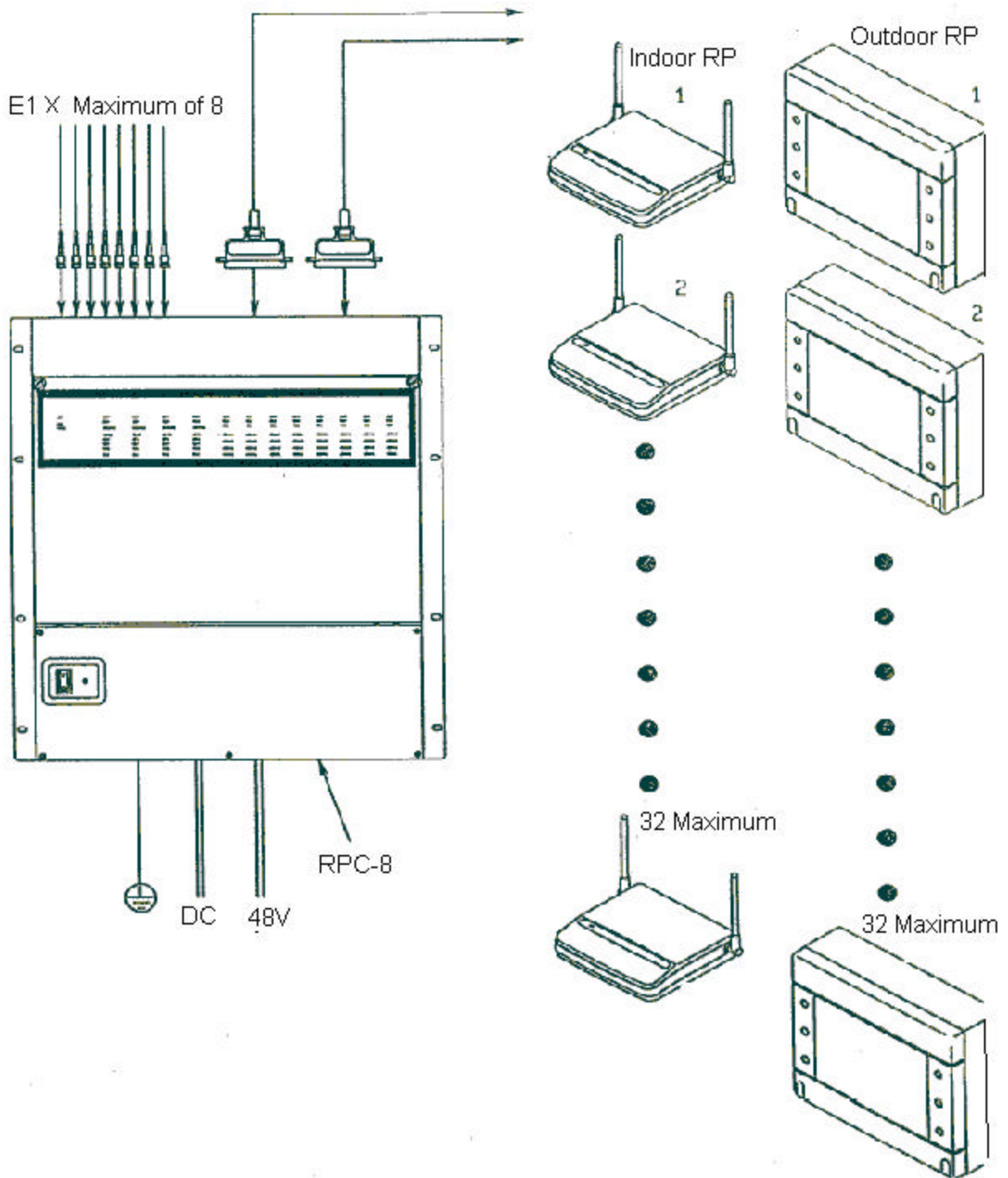

**Figure 3-7: RPC and RP Configuration**

The dimensions of the indoor Radio Port are as follows:

- Height:142 mm

- Width:154 mm
- Depth:47 mm

The dimensions of the outdoor Radio Port are as follows:

- Height:214±2.5 mm
- Width:260±2.5 mm

### 3.3 Indoor RP Installation Instructions

This section provides the instructions for installing an indoor RP. The flow chart in Figure 3-8 describes the steps involved in the installation.

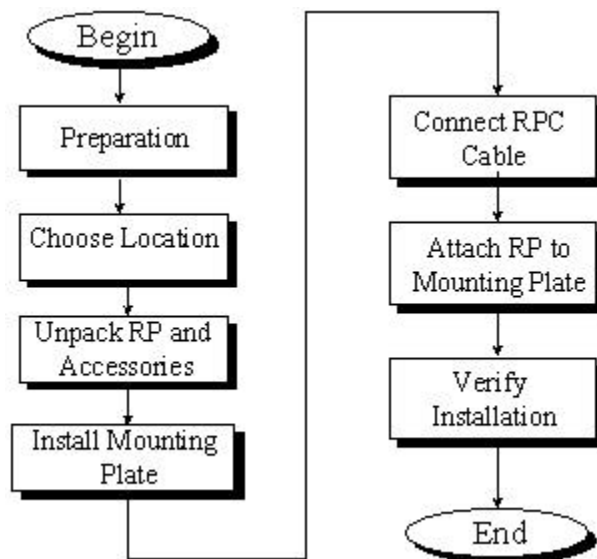

Figure 3-8: Indoor RP Installation Flow Chart

#### 3.3.1 Before Beginning

To ensure that the RP installation goes smoothly, it is necessary to do adequate planning prior to the installation. Things to consider:

- Correct placement of the RP
- Tools required
- Number of people needed to complete the installation

### 3.3.2 Site Selection

For indoor RP installation, select a site that satisfies the following requirements:

- Less than 3 meters from the RP antenna
- Not in direct sunlight or near a heat source such as a radiator
- Free from excessive humidity; not more than 95% non-condensing
- Free from excesses of heat or cold, not lower than  $-10^{\circ}\text{C}$  nor higher than  $+50^{\circ}\text{C}$



NOTE: *If more than 3 meters, consult a qualified field engineer.*

### 3.3.3 Indoor RP Installation

Follow the steps below to install an indoor RP:

1. Carefully unpack the indoor RP and make sure it is in good condition.
2. Attach the mounting plate to a wall with 2 screws as shown in Figure 3-9.

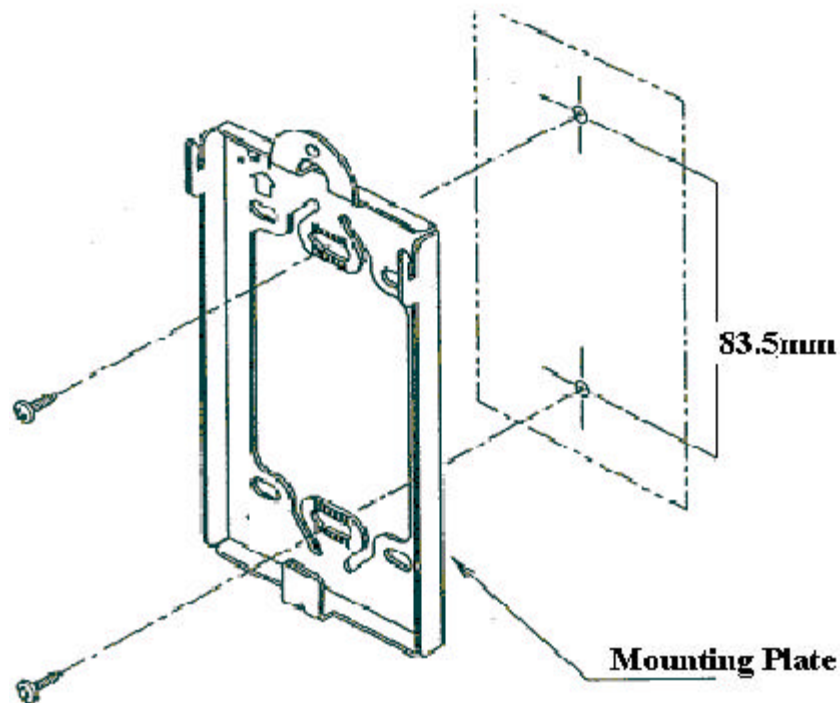
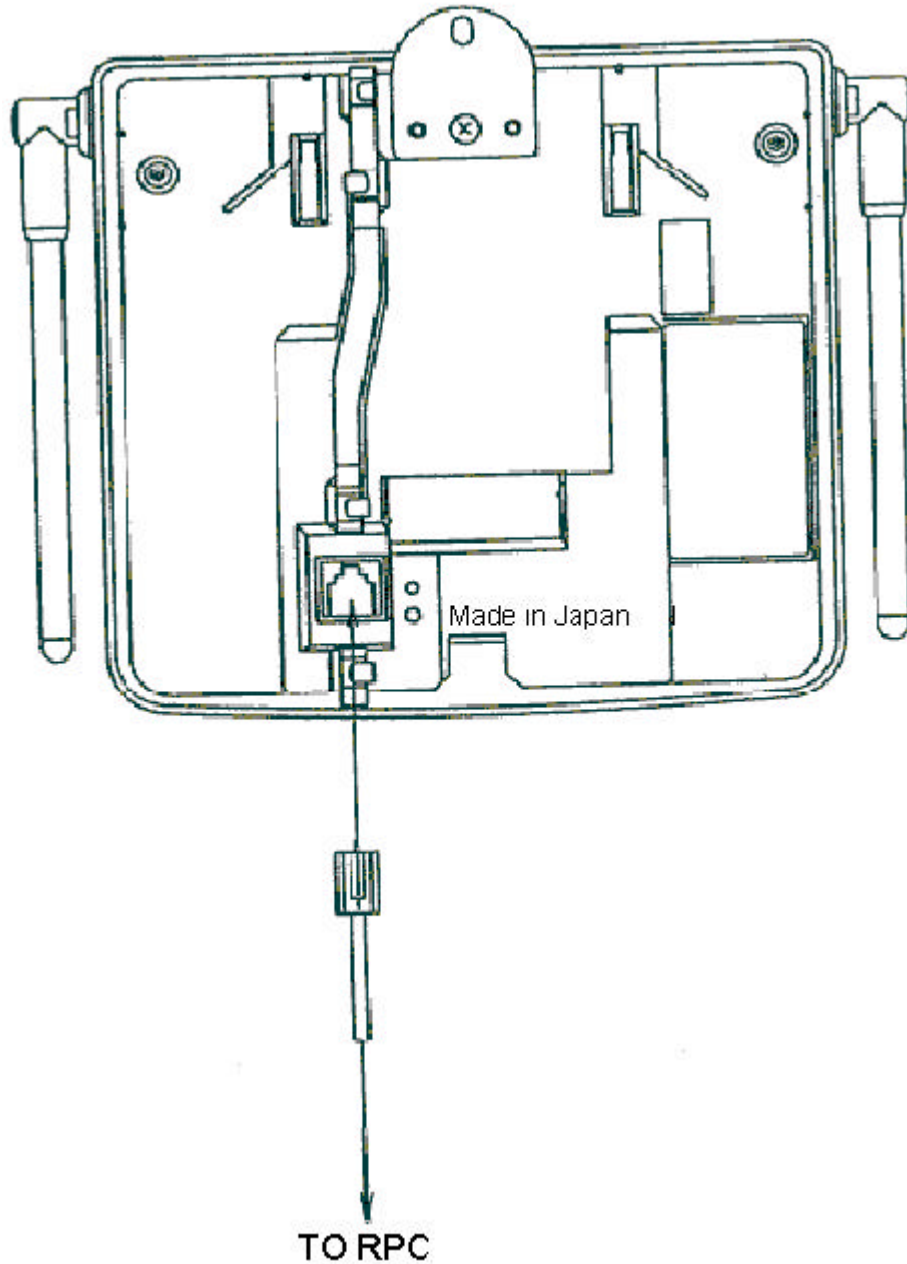

Figure 3-9: Indoor RP Mounting Plate

3. Insert the RJ-11 end of the RPC cable into the connector on the back of the indoor RP. Refer to Figure 3-10.



**Figure 3-10: Connection to RPC**

4. Attach the indoor RP to the mounting plate with the special screw as indicated in Figure 3-11.

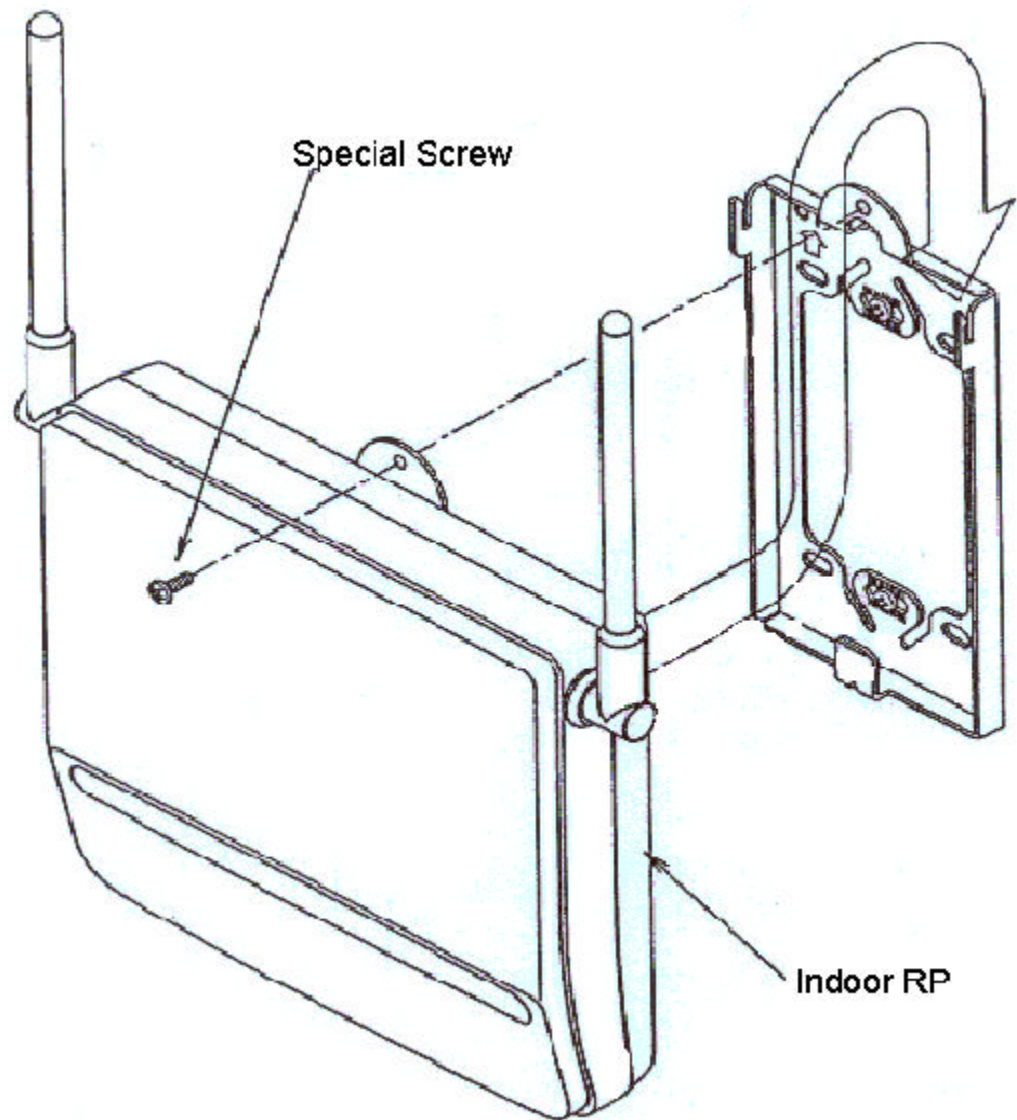

**Figure 3-11: Indoor RP and Mounting Plate**

5. This concludes the installation of the indoor RP.

## 3.4 Outdoor RP Installation Instructions

This section provides the instructions for installing the outdoor RP. The flow chart in Figure 3-12 defines that steps involved in the installation.

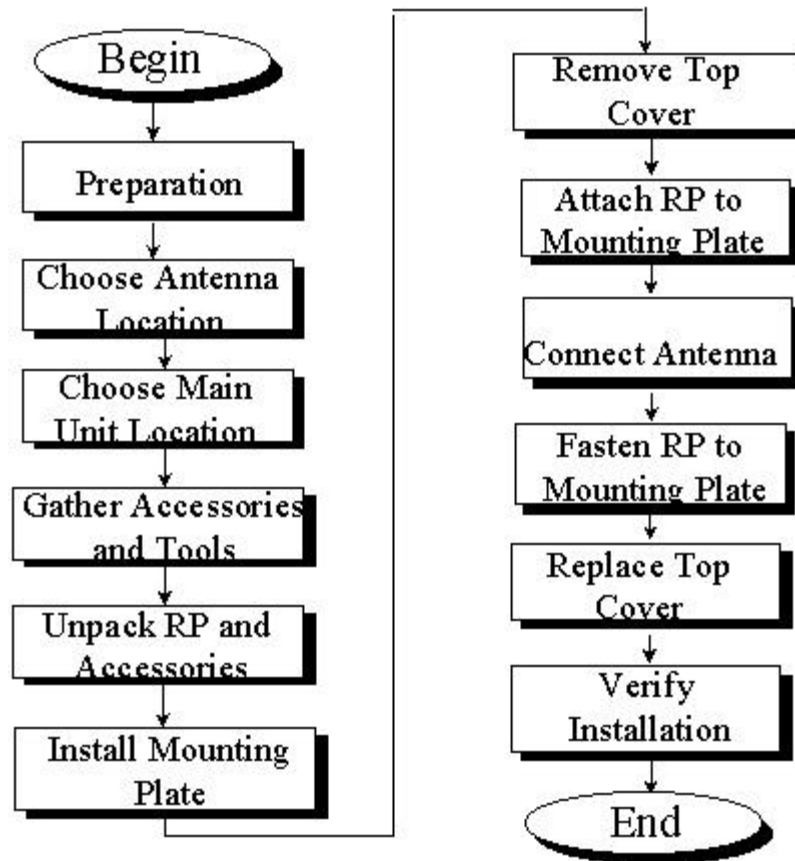

Figure 3-12: Outdoor RP Instruction Flow Chart

### 3.4.1 Before Beginning

To ensure that the outdoor RP installation goes smoothly, it is necessary to make adequate planning prior to the installation, including:

- Tools required
- Number of people needed to complete the installation
- Location of the RP Main Unit

### 3.4.2 Outdoor RP Installation

Follow the steps below to install an outdoor RP:

1. Unpack the outdoor RP and accessories and make sure they are in good condition. Refer to Figure 3-13. The package includes:
  - Outdoor RP (1)

- Mounting plate (2)
- One M4 screw (3)
- Four M6 screws (4)

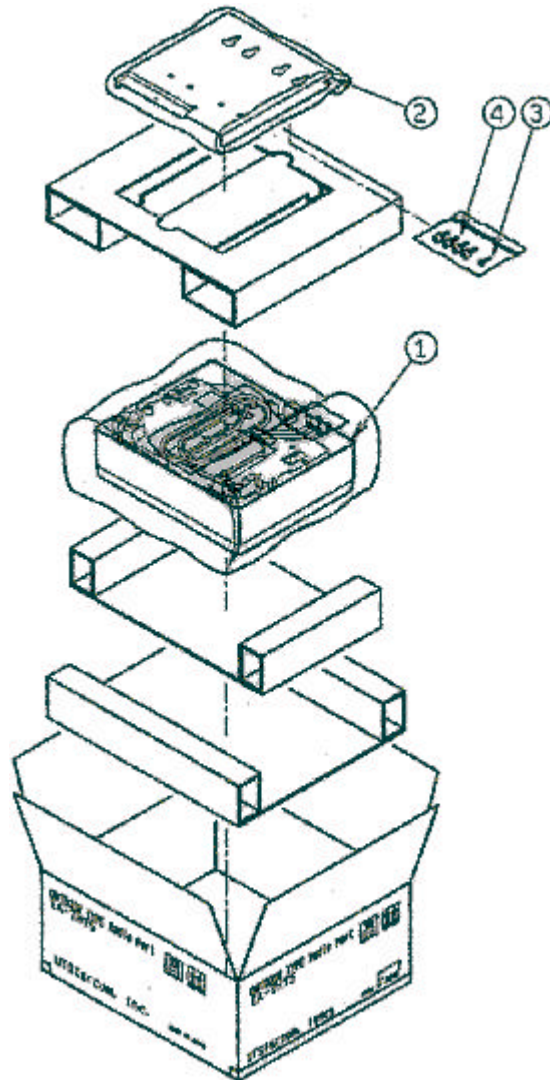

**Figure 3-13: Overview of the RP, Packing, and Accessories**

2. Make sure that the outdoor RP is installed in one of the positions shown in Figure 3-14.



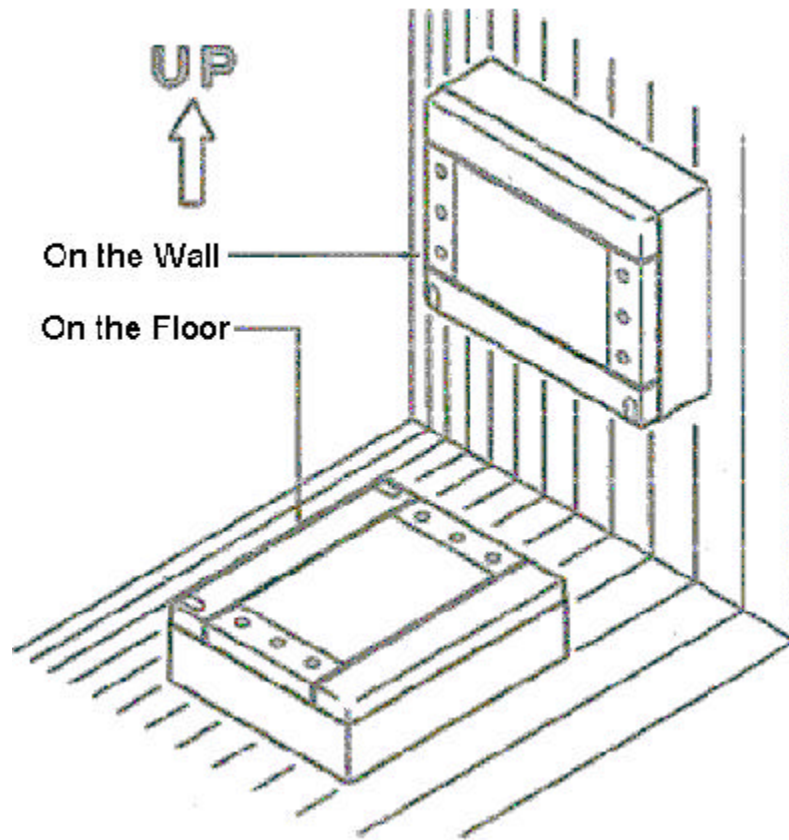
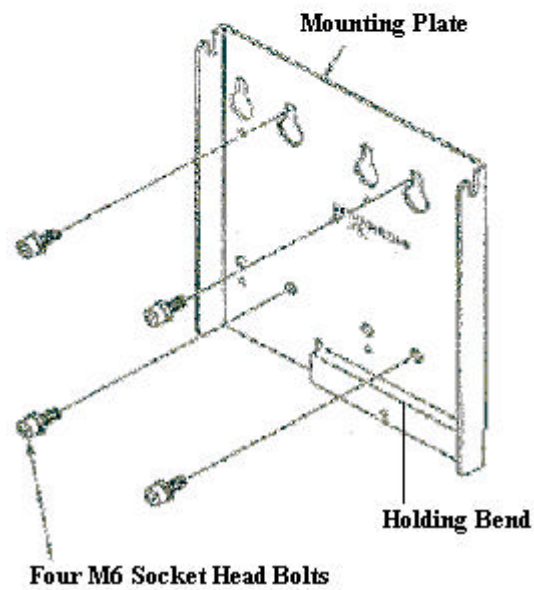
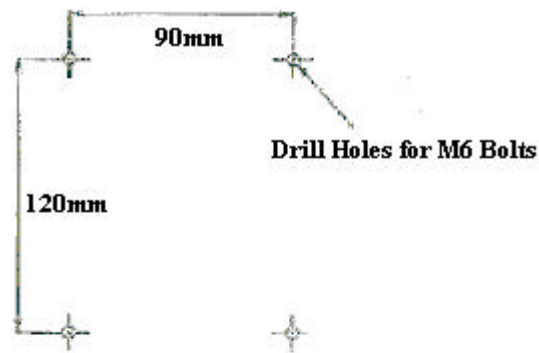

**Figure 3-14: Outdoor RP Recommended Positions**



**WARNING:** *Installation of the RP in any other position may permit moisture to enter the device possibly causing damage or injury.*

3. Pre-drill holes for bolts according to the dimensions shown in Figure 3-15. Attach the mounting plate to a wall with 4 bolts. Notice that the lower right edge of the mounting plate has a bend in it. The purpose of this bend is to hold the antenna connectors in place. Refer to Figure 3-15.



**Figure 3-15: Mounting Plate**

4. To remove the top cover, lower the screw caps and loosen the screws with the special screwdriver. Pull the top cover backward and upward from the main unit as shown in Figure 3-16.

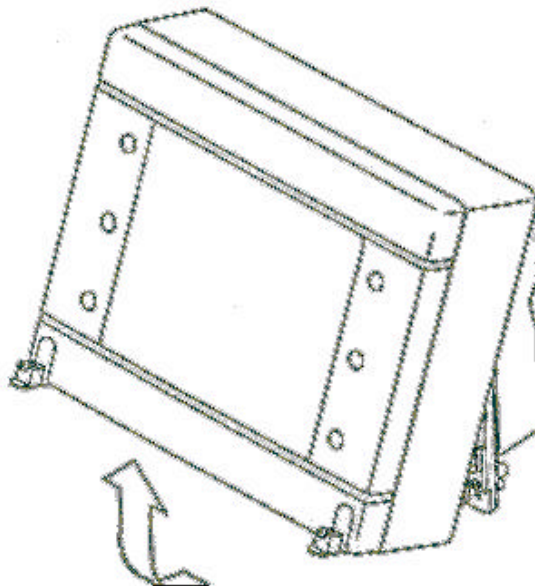
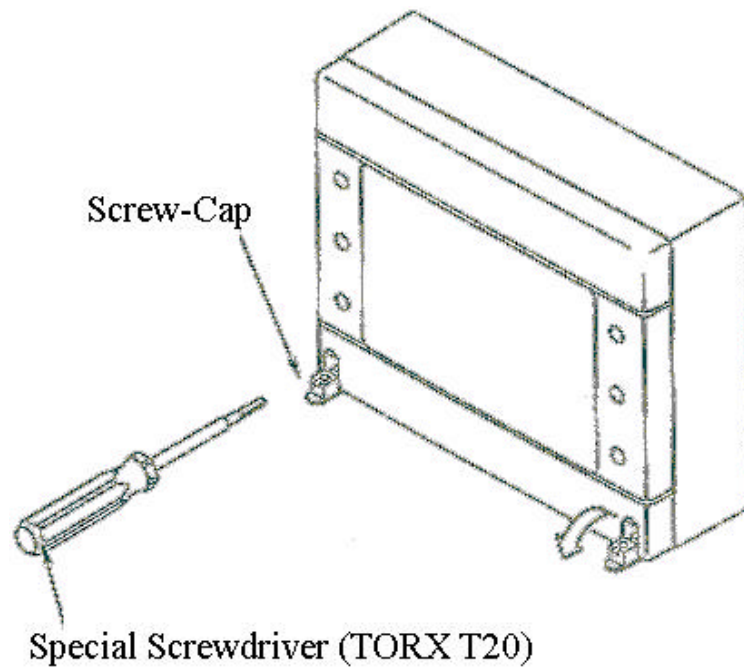

**Figure 3-16: Top Cover Removal**

5. Mount main unit on the mounting plate. Position both the hinge pins in the u-notches on the mounting plate. Refer to Figure 3-17. Do not fasten with the screws right now. The antenna cables must be connected first.

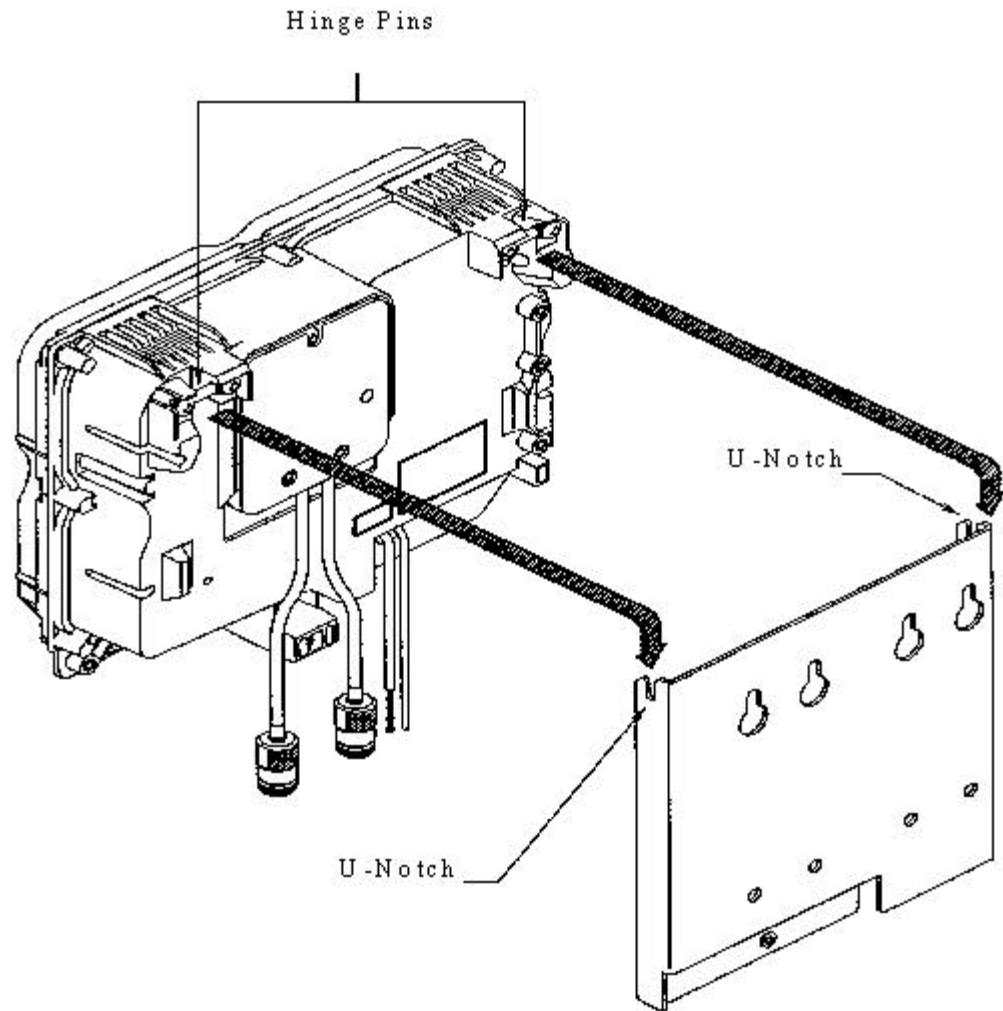

**Figure 3-17: Mount Main Unit**

6. Connect each antenna cable and push the antenna connectors and surplus antenna cable in between the mounting plate and the RP main unit. Make sure that the antenna connectors are above the holding bend of the mounting plate and that the antenna cables are not caught by it.

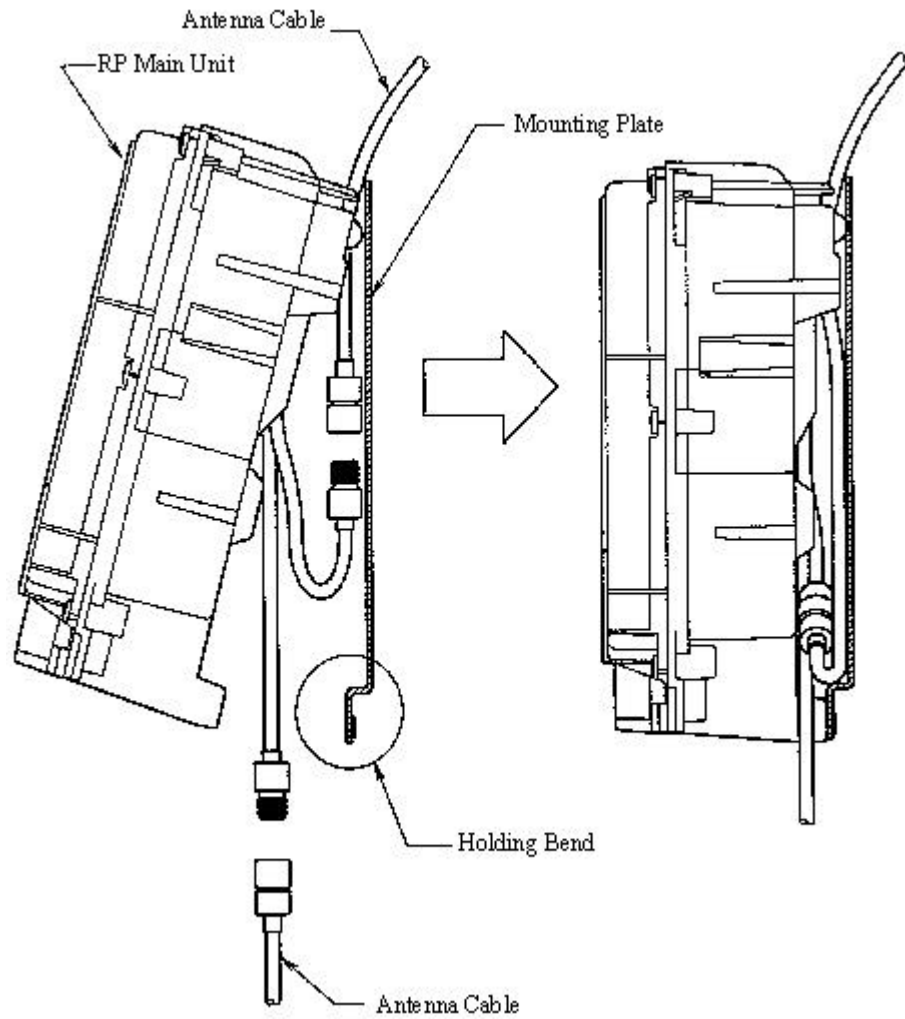

**Figure 3-18: Antenna Cable Connections**

7. Affix main unit to the mounting plate with the M4 screw as shown in Figure 3-19.

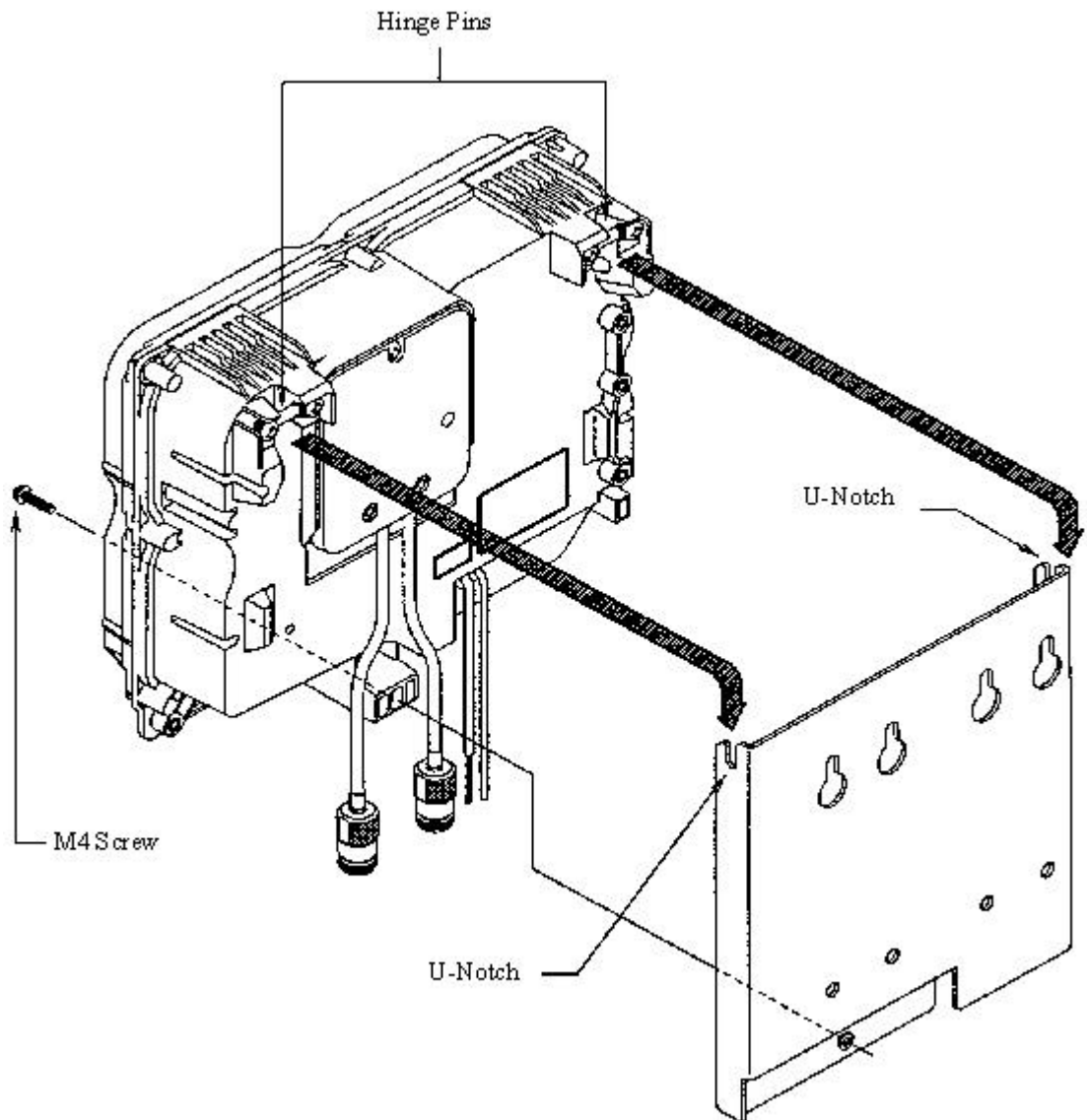

**Figure 3-19: RP Attachment to the Mounting Plate**

8. Replace the top cover. Make sure it is properly positioned over the fin on the main unit as shown in Figure 3-20. Tighten the screws in the top cover and replace the screw caps.

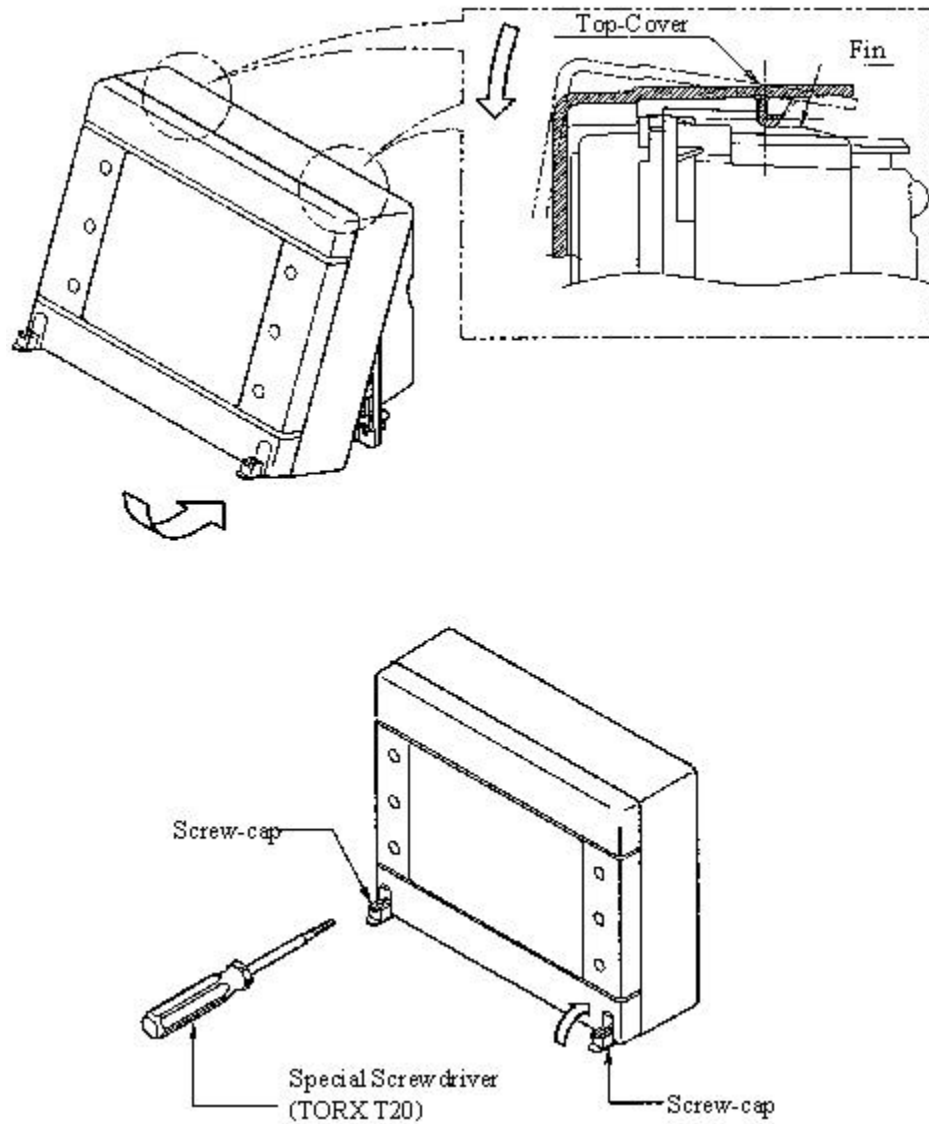

Figure 3-20: Top Cover Attachment

9. This completes the installation of the outdoor RP.





---

# RPC/RP Configuration

---

# 4

After the installation of the RPC and RP, configuration must be made to provision the RPC and RP. This is done through the Netman network management system. Netman is the network management tool for the system. It centralizes the management of all the DMs in the network, including the RPCs. This chapter describes the RPC/RP configuration process through Netman 2000.

## 4.1 Initialize an RPC Node

RPCs are represented as independent DMs on the Netman **Main View** window although they are actually controlled by the COT node to which they are attached. Figure 4-1 and Figure 4-2 represent the toolbar and pull-down menu of the RPC DM window.

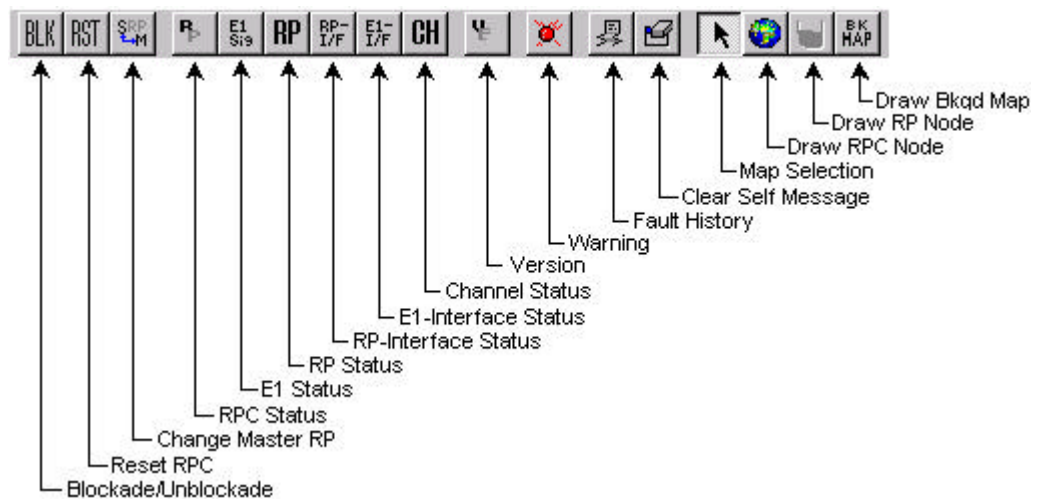

Figure 4-1: Toolbar and Description (RPC R2.4)

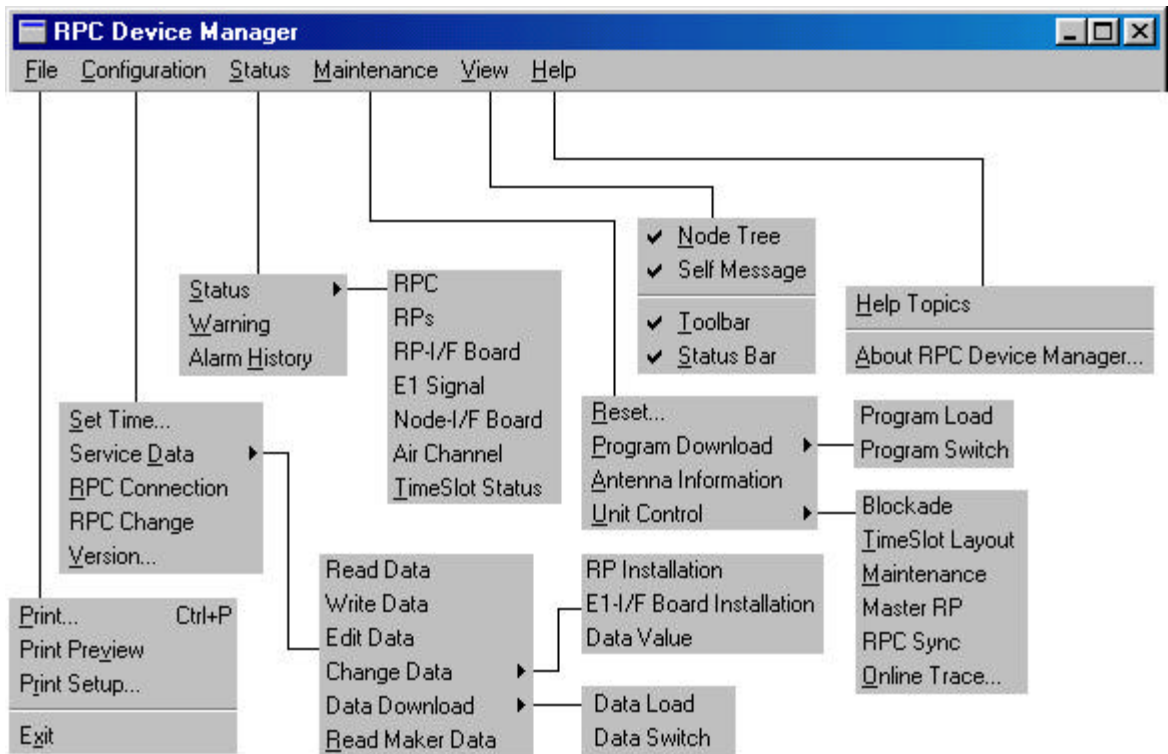

Figure 4-2: Netman Pull-down Menus (RPC R2.4)

This section describes the procedures to initialize an RPC node. Follow the steps below to get connected to an RPC:

1. On the **Main View** window of the Netman network management system, double click the target RPC icon. This opens the **Connect RPCs** window, as shown below.

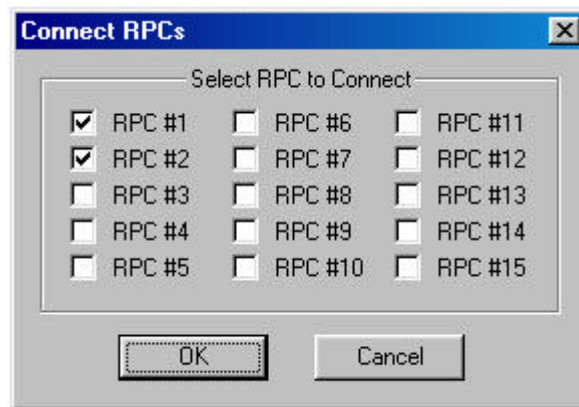
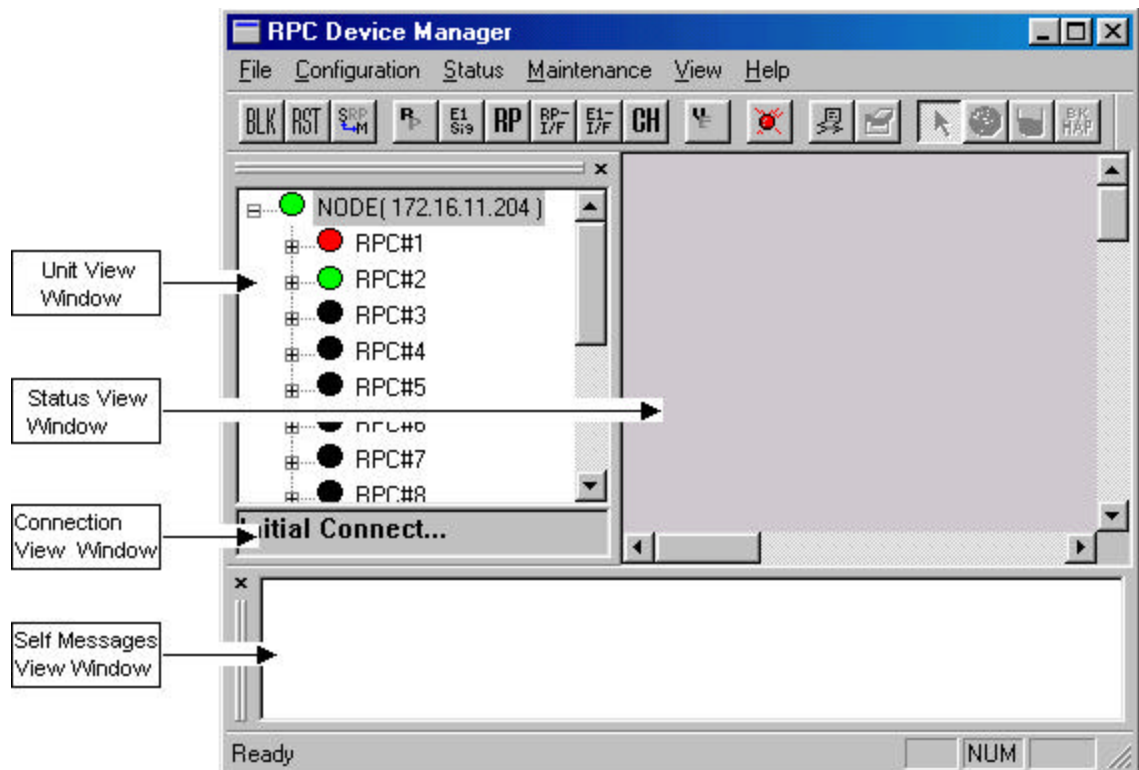

Figure 4-3: Connect RPCs Window

2. There are 15 RPCs to select from. Click the check boxes of the RPCs to be connected and then click **OK**.
3. A connection status box appears, displaying the connection process. When the process is complete, the **RPC** window opens with four frames, as displayed in Figure 4-4.



**Figure 4-4: RPC Window**

The top left frame is called the **Unit View** window. It lists the current units, such as, RPCs, RPs, interfaces, etc. The NODE displays its IP address. The connection status of the RPC nodes on the tree structure is represented in three different colors. The green and red color indicate connected and unconnected RPCs respectively, whereas the RPC nodes in black color indicate that they are not selected for connection.

The top right frame is called the **Status View** window. It displays the relevant status information corresponding to the selection on the left, on the menu bar, or on the toolbar.

The small frame under the **Unit View** window is the **Connection View** window. It displays the connection status and the connected RPC.

Finally, the frame at the bottom is the **Self Messages** window. It displays messages about the command execution results, trap messages, or warnings, if there is any.

4. To get connected to a certain RPC, reselect the RPC by clicking the RPC on the **Unit View** window. A connection status box appears, displaying the connection process. If the connection is successful, a message will appear on the **Connection View** window, stating “Connected to RPC#...” If the connection fails, the message will be: “Not Connected!”
5. When the connection is complete, the **Status View** window displays the relevant status information about the RPC or other units under it, depending on which unit is selected. The figure below illustrates an **RPC** window.

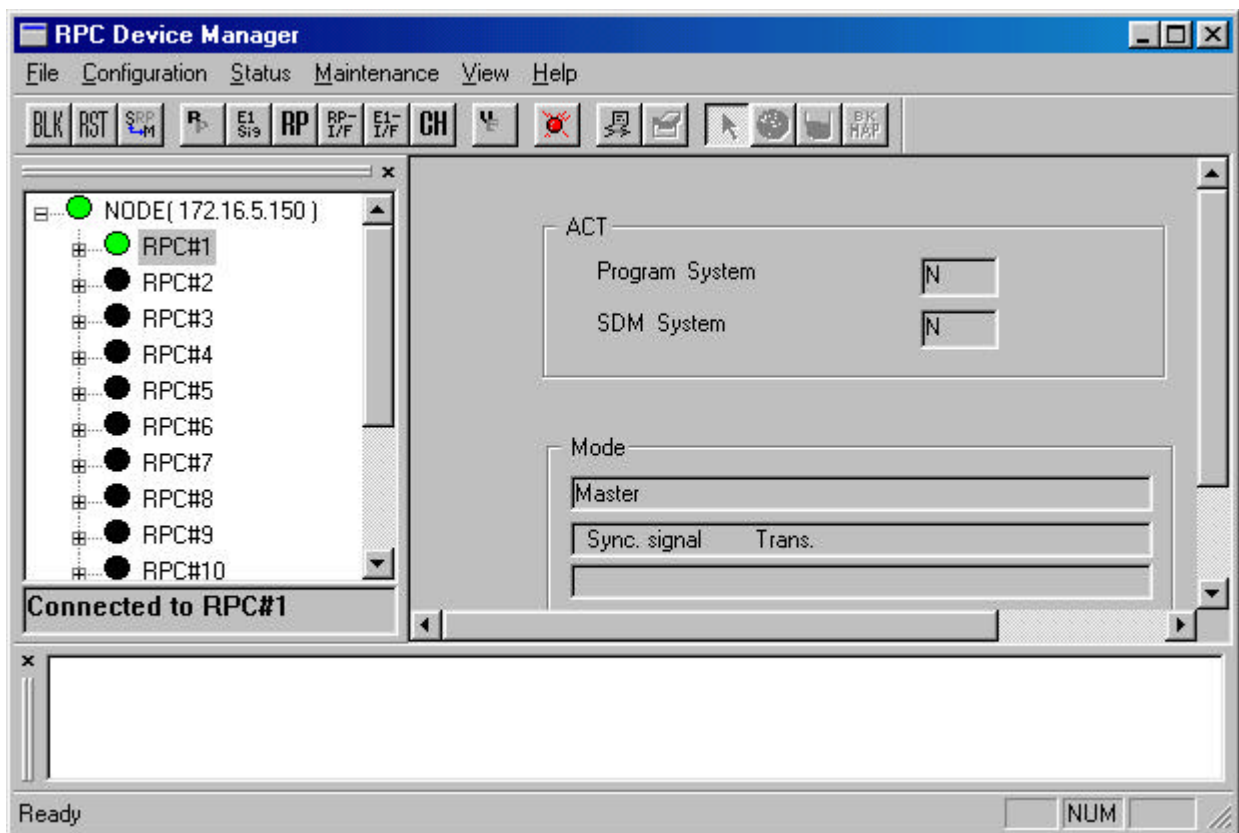

**Figure 4-5: RPC Window**

6. Open an RPC by clicking the + sign to the left of the RPC. This displays the RPs, RP Interface Board, E1 Signal, Node Interface Board, and Air Channel inside. Users may access each of the RPs by clicking the + sign to the left of the RPs. Each RPC controls 32 RPs.

### 4.1.1 Background Map

A street map can be added as a background image on the **Status View** window to highlight the location of the RPC or RP.

1. Click **NODE** on the **Unit View** window to enable the **Draw Background Map** button on the **RPC** window.
2. Click the **Draw Background Map** button and click anywhere on the **Status View** window. The **Background Map** window opens, as shown in Figure 4-6.

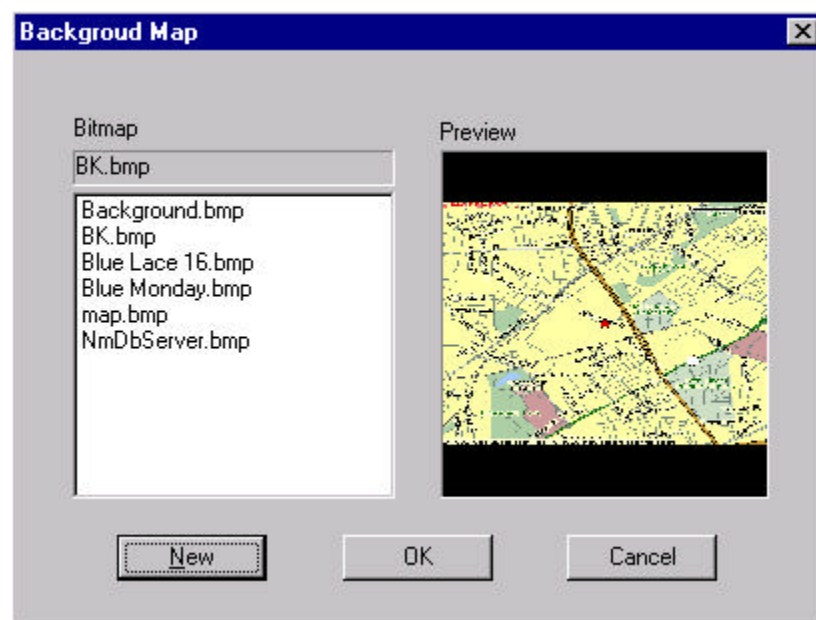

Figure 4-6: Background Map Window

3. Select the target background file from the **Bitmap** field. The **Preview** field displays the selected background image. If users are satisfied with the image, click **OK**. The image is pasted to the background of the **Status View** window, as illustrated in Figure 4-7.

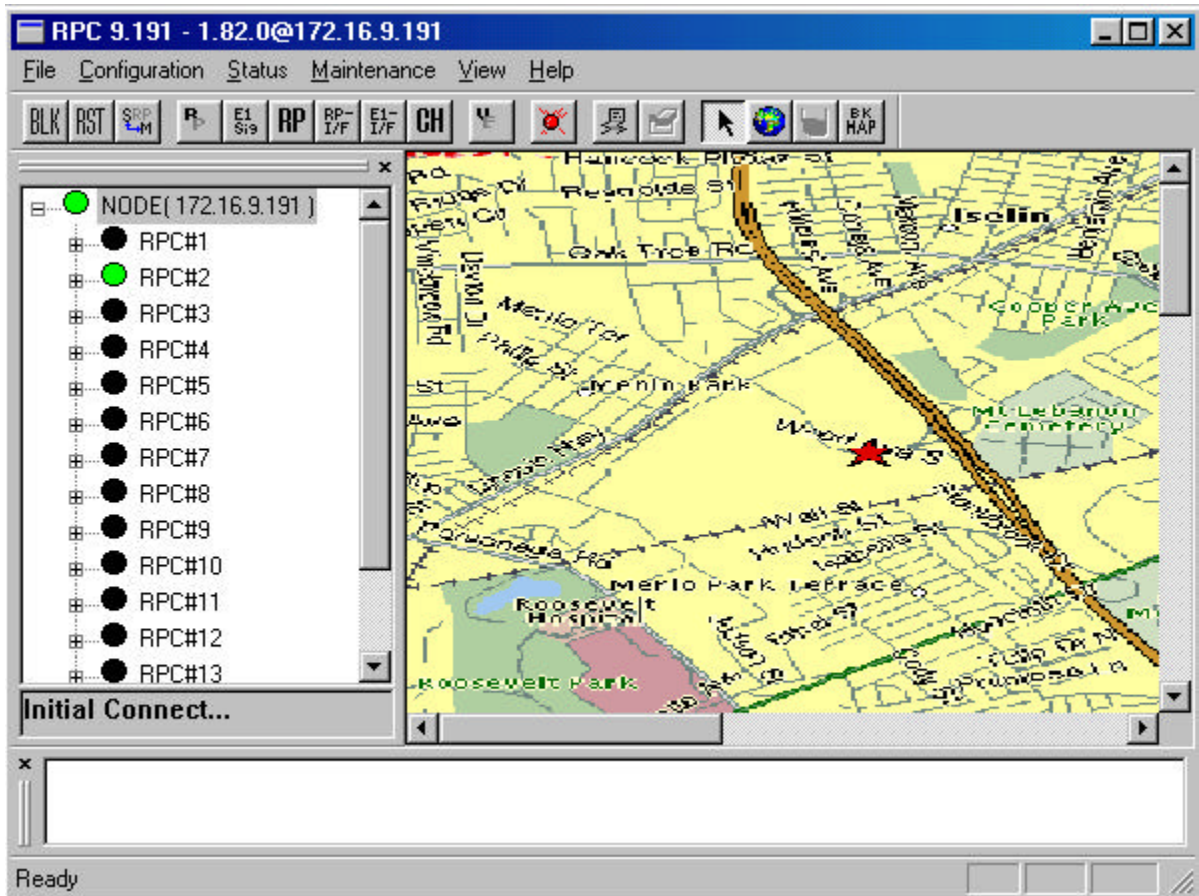
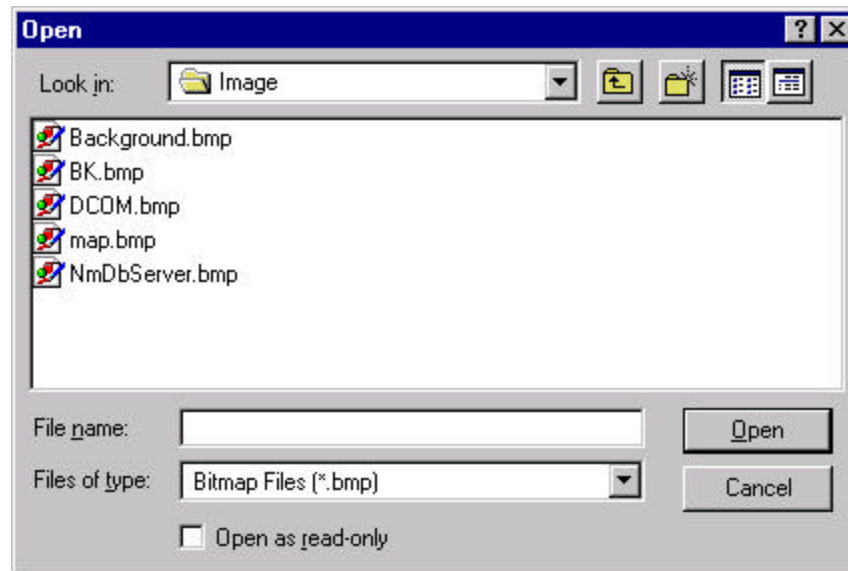

Figure 4-7: RPC Window with Background Image

4. To select another background image other than those on the **Bitmap** field, click the **New** button. The **Open** window appears, as illustrated in Figure 4-8.



**Figure 4-8: Open Window**

5. Select the target bitmap file and click **Open**. The selected image file is added to the **Bitmap** list and displayed on the **Preview** field. Click **OK** to paste the image to the background of the **Status View** window if users are satisfied with the image. A similar window appears, as illustrated previously in Figure 4-7.

### 4.1.2 Add RPC Icons on the Map

RPC icons can be added to the background map to highlight the location information of the RPCs. They can be added, deleted or moved. All map information is stored in the database.

1. To add an RPC icon to the map click the **Draw RPC Node** button on the **RPC** window and click again on the target location of the map. The **Property** window opens as shown in Figure 4-9.

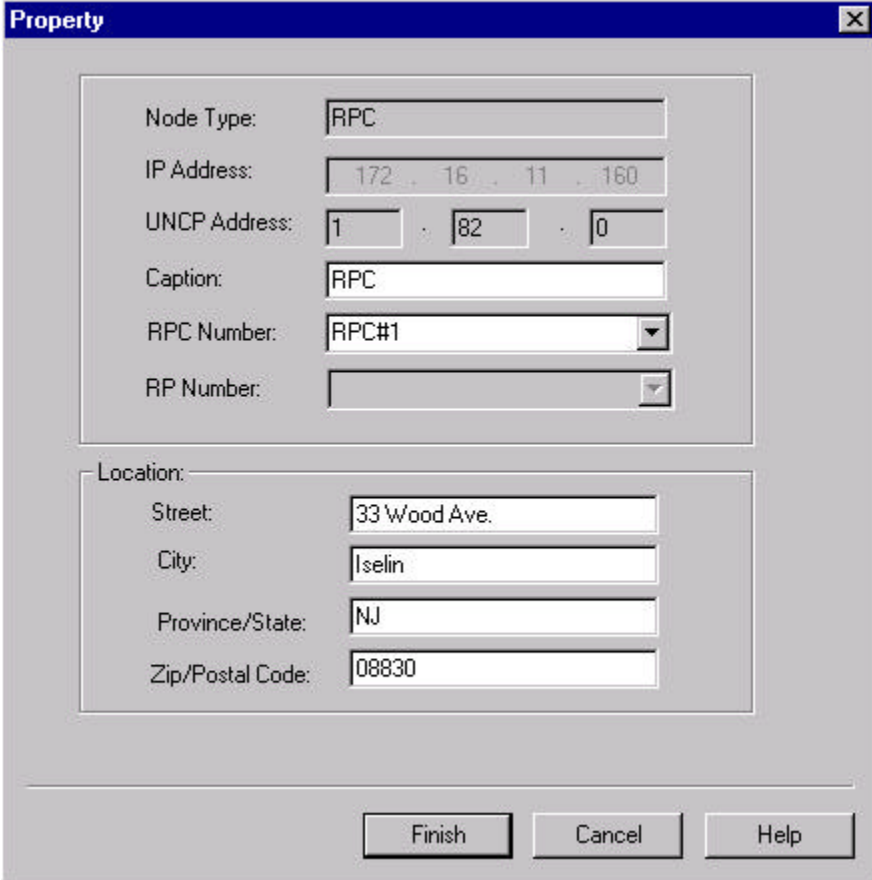

The image shows a Windows-style dialog box titled "Property" with a close button (X) in the top right corner. The dialog is divided into two main sections. The top section contains several input fields: "Node Type" is a text box containing "RPC"; "IP Address" is a text box containing "172 . 16 . 11 . 160"; "UNCP Address" consists of three separate text boxes containing "1", "82", and "0" respectively; "Caption" is a text box containing "RPC"; "RPC Number" is a dropdown menu showing "RPC#1"; and "RP Number" is an empty dropdown menu. The bottom section is titled "Location:" and contains four text boxes: "Street" containing "33 Wood Ave.", "City" containing "Iselin", "Province/State" containing "NJ", and "Zip/Postal Code" containing "08830". At the bottom of the dialog are three buttons: "Finish", "Cancel", and "Help".

**Figure 4-9: RPC Property Window**

2. Users enter the caption name, select the desired RPC number, enter the address for that RPC, and click ***Finish***. The RPC icon appears on the map and the data are stored in the database, as illustrated in the figure below.



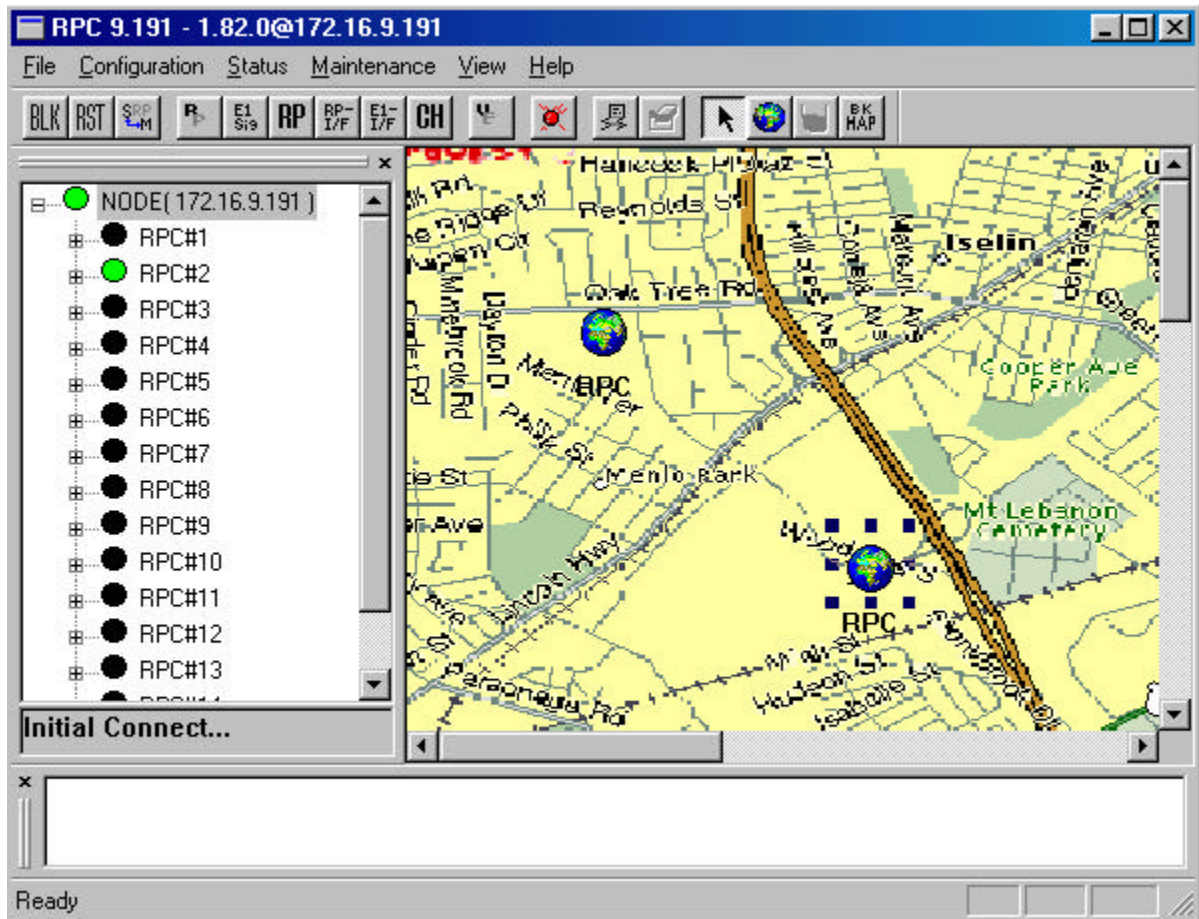

Figure 4-10: RPC Window with RPC icons on the Map

3. The RPC icons can be moved, deleted, or moved to the front or back of the background map. Their properties can also be modified. To perform these operations right click the target RPC icon and select the relevant option from the pop-up menu.

### 4.1.3 Add RP Icons

RP icons can be added to the map under the dominant RPC. Follow the steps below to perform the operation.

1. Double click the target RPC to access the blank **Status View** window and to enable the **Draw RP Node** button. Now users can add the same background map to the window. Following the procedure in the previous section to add the background map. To add the RP icons on the map, click the **Draw RP Node** button and click again on the target location of the map. The RP Property window opens as illustrated in Figure 4-11.

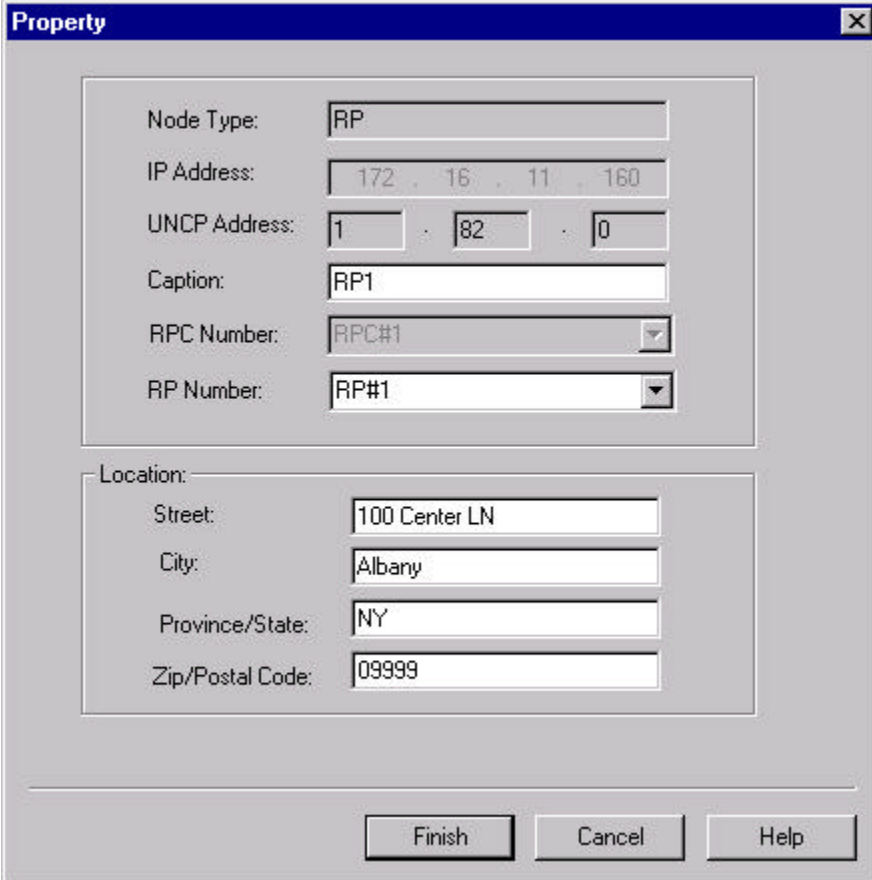

The image shows a Windows-style dialog box titled "Property" with a close button (X) in the top right corner. The dialog is divided into two main sections. The top section contains several input fields: "Node Type" with a text box containing "RP"; "IP Address" with a dotted text box containing "172 . 16 . 11 . 160"; "UNCP Address" with three dotted text boxes containing "1", "82", and "0"; "Caption" with a text box containing "RP1"; "RPC Number" with a dropdown menu showing "RPC#1"; and "RP Number" with a dropdown menu showing "RP#1". The bottom section is titled "Location:" and contains four text boxes: "Street" with "100 Center LN", "City" with "Albany", "Province/State" with "NY", and "Zip/Postal Code" with "09999". At the bottom of the dialog are three buttons: "Finish", "Cancel", and "Help".

**Figure 4-11: RP Property Window**

2. This window is similar to that in Figure 4-9. Enter the relevant data into the fields and click ***Finish***. The RP icon appears on the map and the data are stored in the database. Repeat this process to add as many RP icons as needed. Figure 4-12 illustrates a map with three RP icons.

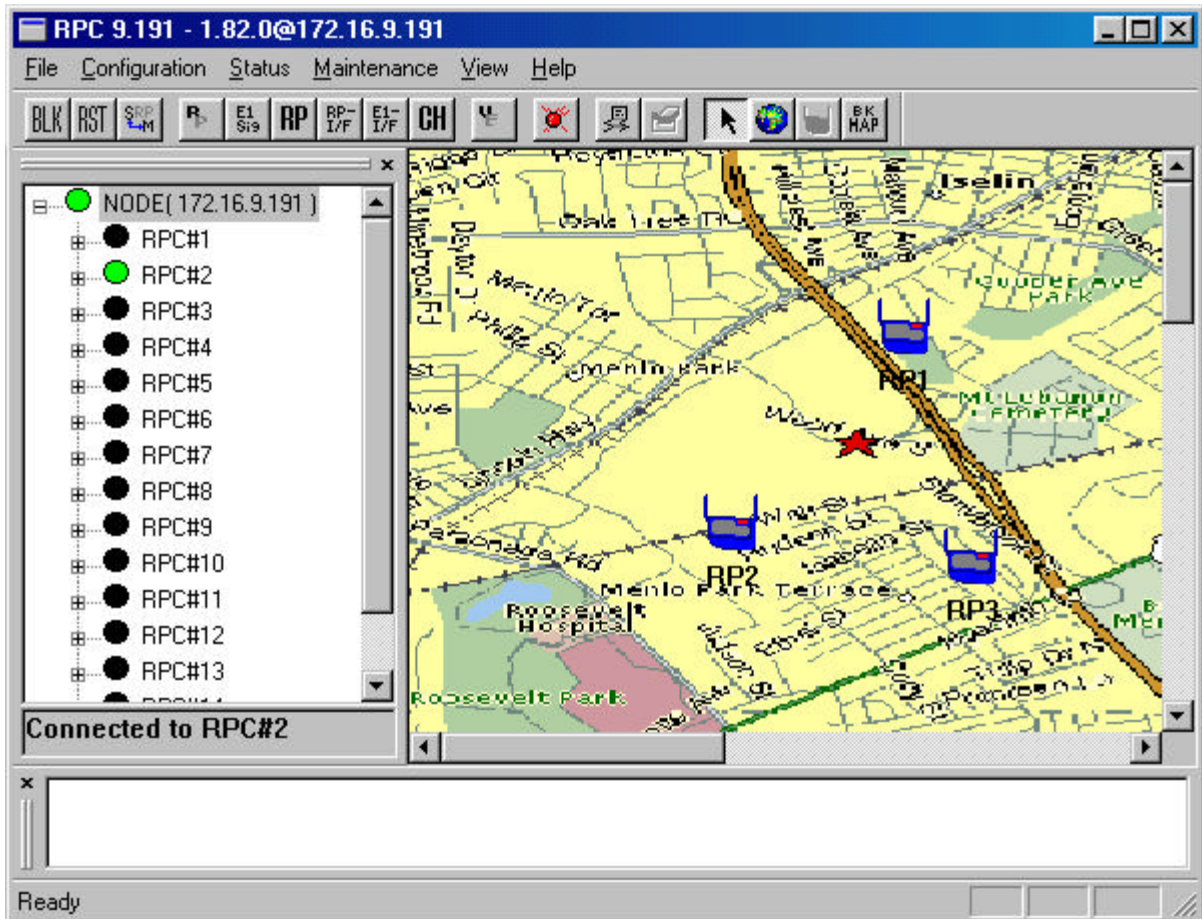

Figure 4-12: RP Map Window

3. To return to the RPC map, click Node on the **Unit View** window. To re-access the RP map, double click the target RPC icon on the RPC map.
4. The RP icons can be moved, deleted, or moved to the front or back of the background map. Their properties can also be modified. To perform these operations right click the target RP icon and select the relevant option from the pop-up menu.

## 4.2 RPC Configuration

This section describes the procedures of provisioning an RPC. Double click the target RPC node on the **Main View** window to open the **Connect RPCs** window. Select the target RPCs and click **OK**. This opens the **RPC** window, as illustrated in Figure 4-13. With this window open we can perform various types of configuration to the connected RPCs.