



## Table of Contents

### Chapter 1:

Product Overview .....	1
Package Contents .....	1
System Requirements .....	1
Network Topology Requirements .....	1
Front .....	2
Back .....	2

### Chapter 2:

Installation .....	3
Hardware Installation.....	3
Software Installation.....	5

### Chapter 3:

Using the UniFi Controller Software .....	7
Map.....	7
Statistics .....	9
Access Points.....	9
Users.....	10
Guests .....	10
Recent Events .....	11
Alerts .....	15
Settings.....	15
Admin .....	17

### Appendix A:

Specifications.....	18
---------------------	----

### Appendix B:

Compliance Information .....	19
FCC .....	19
Industry Canada.....	19

### Appendix C:

Warranty .....	20
General Warranty.....	20

### Appendix D:

Contact Information .....	21
Ubiquiti Networks Support .....	21

# Chapter 1: Product Overview

Thank you for purchasing the Ubiquiti UniFi Enterprise WiFi System. The UniFi Enterprise WiFi System includes the UniFi Controller software that allows you to manage your wireless network using your Web browser.

The UniFi Enterprise WiFi System also includes the necessary hardware for mounting the unit on a wall or a ceiling. The UniFi Enterprise WiFi System supports Passive PoE which works with the included PoE adapter. If you want to power the UniFi AP from an 802.3af compliant switch, Ubiquiti Networks offers the optional Instant 802.3af Adapter to instantly transform any PoE device into a fully 48V 802.3af compliant product. Product details are available on our website at <http://ubnt.com/8023af>

## Package Contents

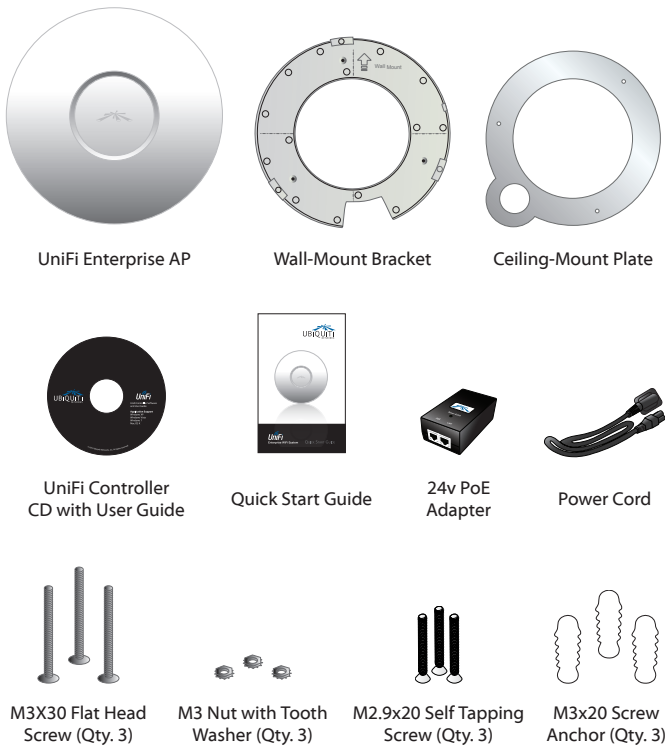

## System Requirements

- Microsoft Windows XP, Windows Vista, Windows 7, or Mac OS X
- Java Runtime Environment 1.6 (or above)
- Web Browser: Mozilla Firefox, Google Chrome, or Microsoft Internet Explorer 8 (or above)

## Network Topology Requirements

- A DHCP-enabled network (for AP to obtain an IP as well as for the wireless clients after the deployment)
- Access point(s) and the management station computer connected to the same layer-2 network.

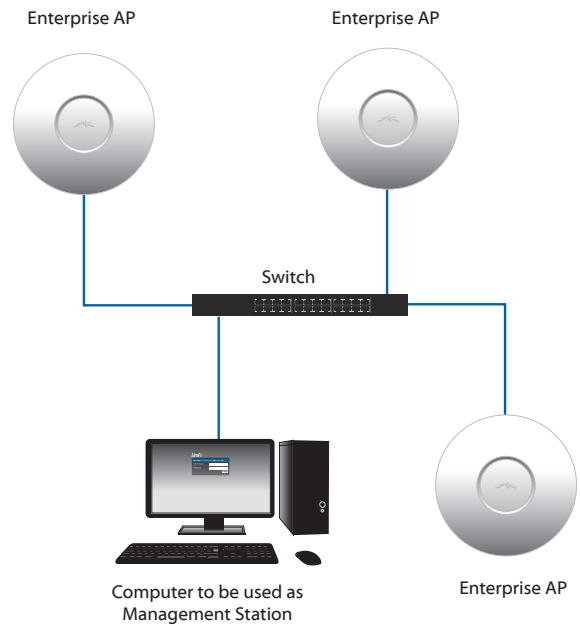

Sample Network Diagram

## Front

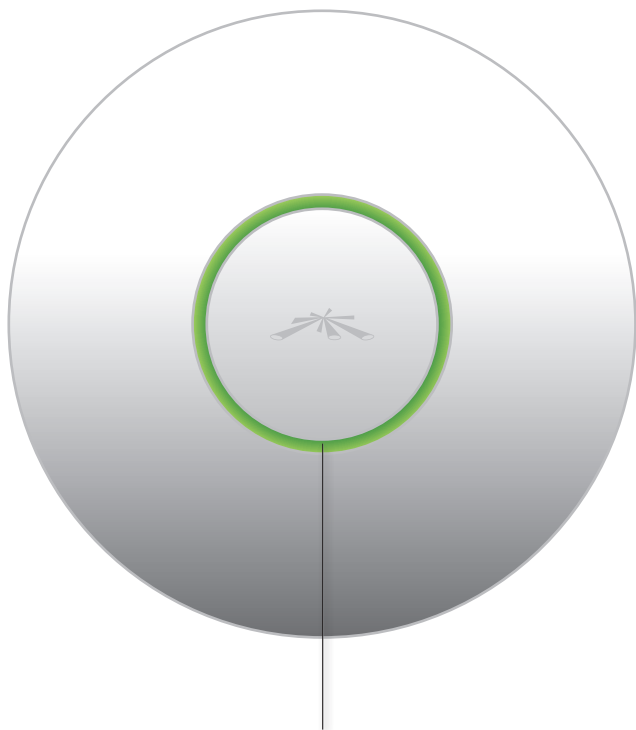

**LED** Indicates the status of the device. See the table below for details.

## Back

**Reset Button** The reset button serves two functions:

- **Restart** It will restart the device when you press and release it quickly.
- **Restore Factory Defaults** When you press and hold it for more than 5 seconds, it will restore the device to the factory default settings.

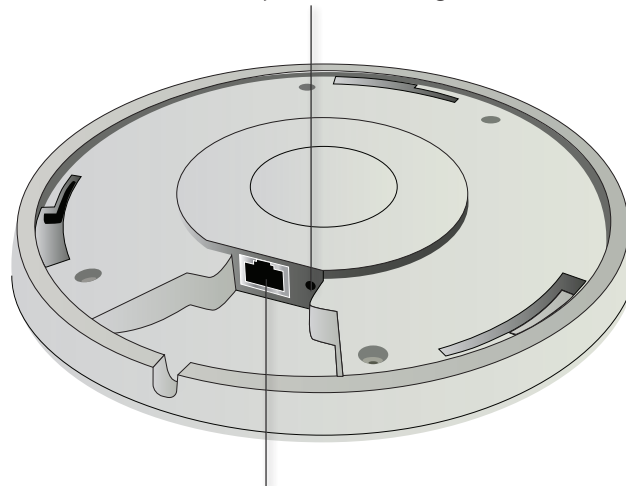

**Ethernet Port** Connects to the 24v PoE Adapter to provide power to the unit.

LED Color	Status
Flashing Amber	Initializing
Steady Amber	Factory default, waiting to be integrated
Alternating Amber/Green	Device is busy, do not touch or unplug it, this usually indicates a process such as a firmware upgrade is taking place
Quickly Flashing Green	This is used to locate an AP. When you click on <b>Locate</b> in the UniFi Controller software, the AP will blink. It will also display the location of the AP on the map.
Steady Green	Indicates the device has been successfully integrated into a network and is working properly

# Chapter 2: Installation

## Hardware Installation

The UniFi Enterprise AP is powered by the included PoE (Power over Ethernet) adapter. To install the AP, perform the following steps:

1. Connect an Ethernet cable to the Ethernet port on the UniFi Enterprise AP.

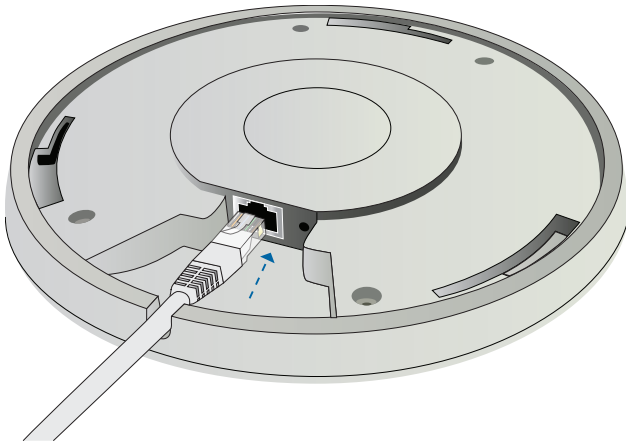

2. Connect the power cord to the power port on the PoE Adapter. Connect the other end to of the power cord to a power outlet.



3. Connect the other end of the Ethernet cable to the Ethernet port labeled POE on the PoE Adapter.



**Note:** If you plan to mount the AP on your ceiling, perform the ceiling mount installation steps before connecting the Ethernet cable to the PoE Adapter.



Below is an overview of the Power over Ethernet connections.



Power Connection Diagram

## Mounting the Access Point

The UniFi Enterprise AP can be wall-mounted or mounted on a ceiling. Perform the following steps for the appropriate installation:

### Wall-Mount

1. Align the wall-mounting bracket with the *Wall Mount* text facing up. There are horizontal and vertical lines on the bracket to help with orientation.

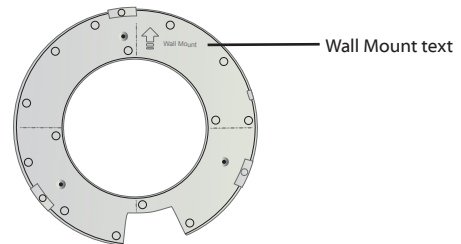

2. Use a pencil to mark the holes on the wall.
3. Use a 6 mm drill bit to drill the holes in the wall.
4. Insert the 3 screw anchors into the wall.
5. Secure the wall-mount bracket to the wall by inserting the self tapping screws into the anchors.

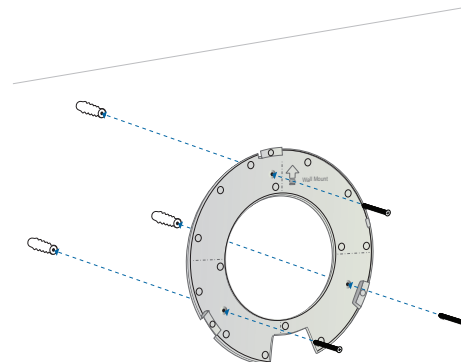

- Align the notches on the AP with the notches on the wall-mount bracket.

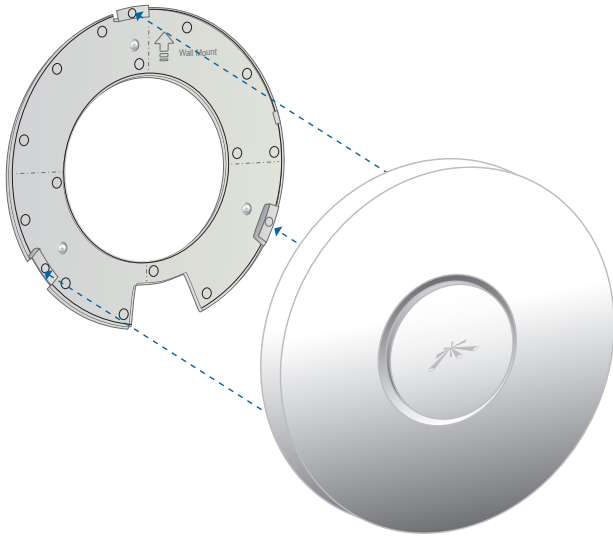

- Turn the AP clockwise until it locks into place.

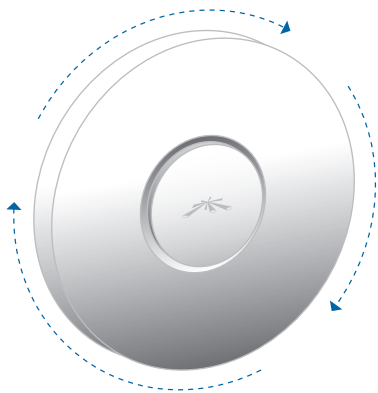

### Ceiling-Mount

- Remove the ceiling tile.
- Align the ceiling-mount plate to the center of the top side of the ceiling tile.
- Use a 3.5 mm drill bit to drill holes for the three flat head screws.
- Cut or drill a circle approximately 25 mm in size that lines up with the larger circle on the ceiling-mount plate. This will be used for the Ethernet cabling.
- Secure the wall-mount bracket and ceiling-mount plate to the ceiling tile using the 3 flathead screws and 3 nuts with tooth washers.

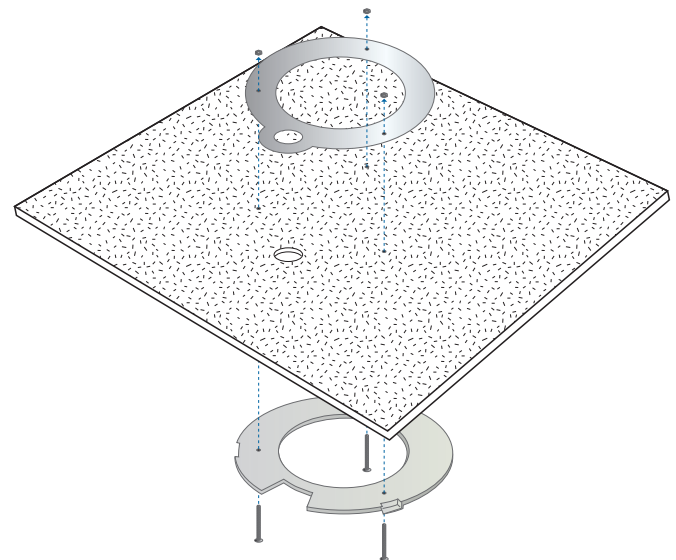

- Feed the Ethernet cable through the hole and then align the Enterprise AP with the notches on the wall-mount bracket.

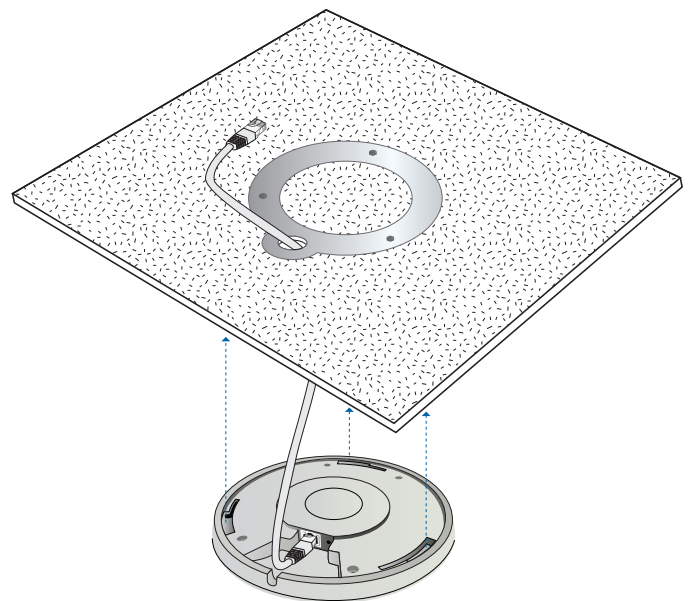

**Note:** The UniFi AP supports Passive PoE which works with the included PoE adapter. If you want to power the UniFi AP from an 802.3af compliant switch, Ubiquiti Networks offers the optional Instant 802.3af Adapter to instantly transform any PoE device into a fully 48V 802.3af compliant product. Product details are available on our website at <http://ubnt.com/8023af>

- Turn the AP clockwise until it locks into place.

## Software Installation

Insert the UniFi Controller software CD into your CD-ROM drive and follow the instructions for your specific computer type.

### Mac Users

1. Click on the **Install** icon.



2. Click **Continue** and follow the on-screen instructions to install the software.



3. Go to **Go > Applications** and double-click the *UniFi* icon.



Proceed to *Configuring the UniFi Controller Software* on page 6.

### PC Users

1. Launch **UniFi-installer.exe**.
2. Click **Install**.



3. If your computer doesn't have Java 1.6 or above installed, you will be prompted to install it. Click **Install** to continue.



4. Click **Next**.

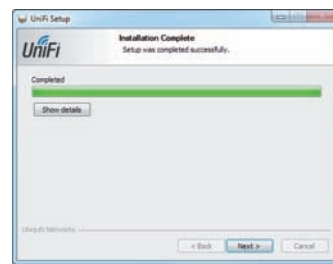

5. Be sure the *Start UniFi Controller after installation* option is checked and click **Finish**.

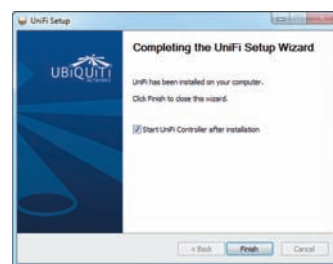

**Note:** The UniFi Controller software can also be launched from **Start > All Programs**.

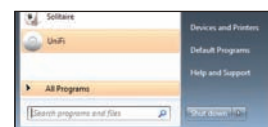

## Configuring the UniFi Controller Software

1. The UniFi Controller software startup will begin. When the option becomes available, click **Launch a Browser to Manage Wireless Network**.



2. Select your language and country. Click **Next**.

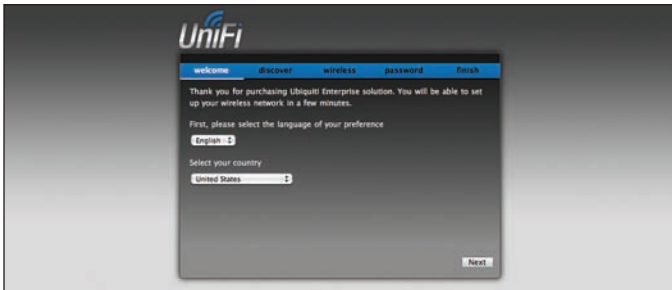

3. Select the devices that you want to configure and click **Next**.

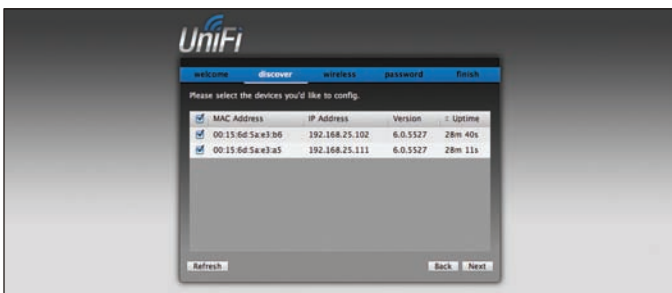

4. The UniFi Installation Wizard will create a secure primary wireless network for your devices. Perform the following steps:
  - a. Enter the wireless network name (SSID) in the *Secure SSID* field.
  - b. Enter a passphrase to be used for your primary network.
  - c. To enable guest access, select **Enable Guest Access** and enter a guest network name in the *Guest SSID* field.
  - d. Click **Next**.



5. Enter an admin name and password to use when accessing the management interface. Confirm your password in the *Confirm* field. Click **Next**.



6. Review your settings. Click **Back** to make changes or **Finish** to save your settings. Once finished you will be redirected to the management interface via your web browser.



Congratulations, your wireless network is now configured. A login screen will appear for the UniFi Controller management interface. Enter the admin name and password that you created and click **Login**.



Proceed to the next chapter for information on using the UniFi Controller software.



# Chapter 3: Using the UniFi Controller Software

The UniFi Controller software that comes with your UniFi Enterprise WiFi System has a browser-based interface for easy configuration and management.

To access the interface, perform the following steps:

1. Launch the UniFi Controller application if hasn't already been started.
  - Mac users: **Go > Applications > UniFi**
  - PC users: **Start > All Programs > UniFi**
2. The login screen will appear. Enter the admin name and password in the appropriate fields and click **Login**.



## Map

The UniFi Controller software allows you to upload map images of your location(s) for a visual representation of your wireless network. When you initially launch the UniFi Controller application, a default map is displayed.

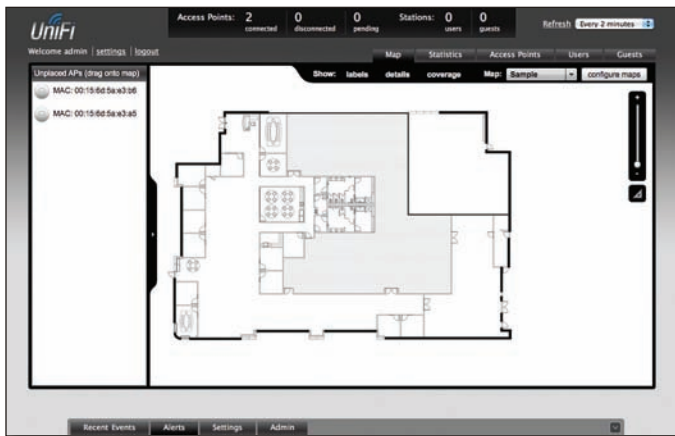

To add a custom map, you must first create the image using an illustration, image editing, or blueprint application that exports .jpg, .gif, or .png file formats.

Once you've created the map, you can upload it to the UniFi Controller software by performing the following steps:

1. Click **Configure Maps**.



2. Click **Add a Map**.

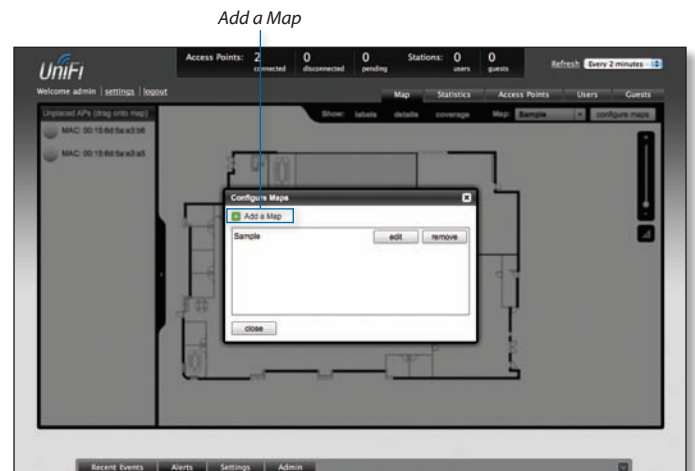

3. Browse for an image to use as a map (valid file formats are .jpg, .gif, and .png). Give the image a brief description. Click **Continue**.

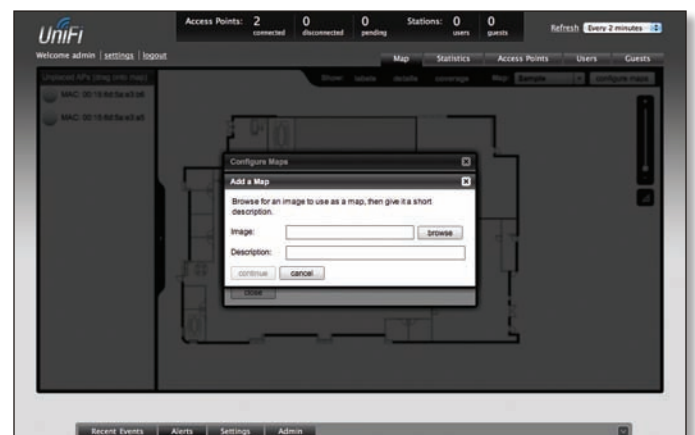

4. Click **Close**.

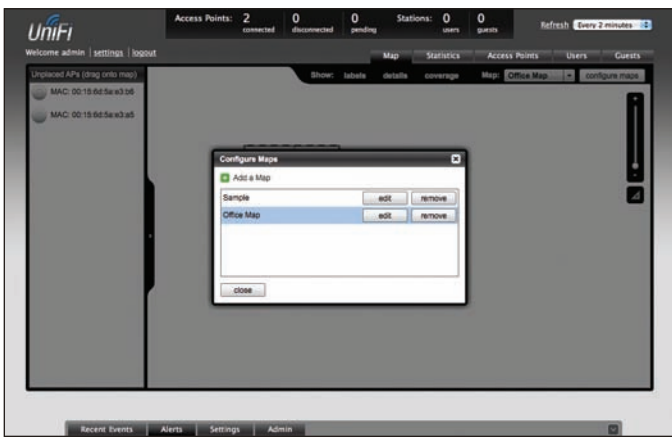

5. You can adjust the zoom using the slider on the right. Drag the *Access Point* icon(s) from the *Unplaced APs* list on the left to the appropriate location(s) on the map.

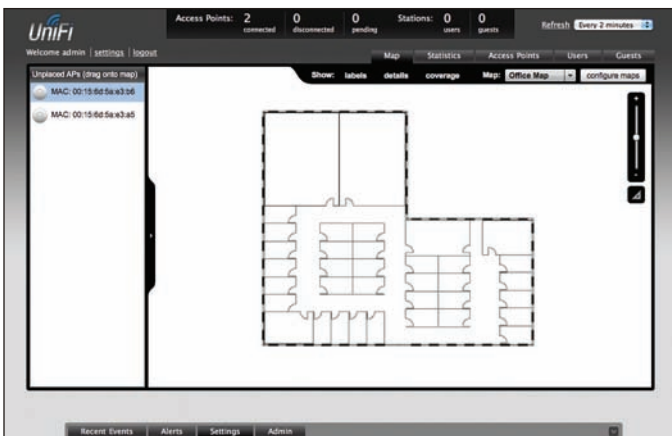

The access point will appear in the area that you placed it.

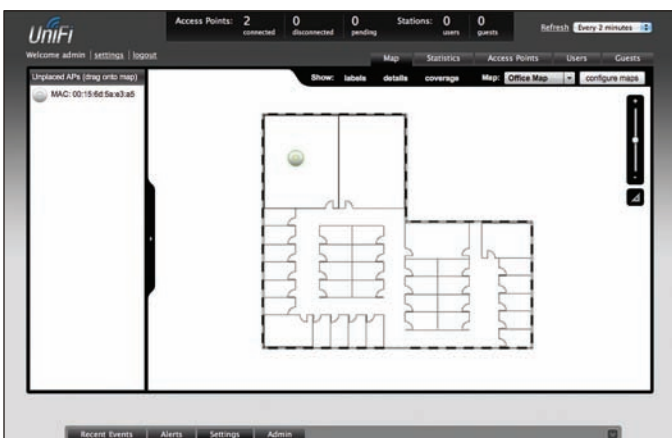

**Access Point** Shows the location of the Access Point on the map.

Click and hold this icon to drag the Access Point to another location on the map. Click on the *Access Point* icon to reveal additional options. Click a blank area of the map to hide the additional options.



**Lock** Locks the selected Access Point in the current location on the map.



**Details** Brings up the *Details* window. This allows you to view Access Point settings and connected users. You can also edit the radio channel, transmit power, and device alias.



There are 4 tabs to select from in the *Details* window. Details, Users, Guests, and Configuration.

- **Details** Displays details on the Access Point including the MAC address, model, version, IP address, uptime, connected users, and connected guests. Click **Radio** to display the channel used, transmit power, and packet information.
- **Users** Displays the hostname of the users that are connected to the selected Access Point and the IP address assigned to them. You can click on the hostname to display additional details of each user. A window with Details, Statistics, and Configuration is displayed. The *Details* tab displays the MAC address, hostname, IP address, uptime and the AP they are connected to. The *Statistics* tab displays the channel used, signal strength, transmit and receive rates, power saving enabled or disabled, and the number of packets sent and received. You can also click **History** to see a sortable list of events. The *Configuration* tab allows you to change the alias name for the device.
- **Guests** Displays the MAC address of guests that are connected to the guest network.
- **Configuration** Allows you to change the alias name of the device, the channel setting, and set the transmit power to Auto, High, Medium, or Low. You can also remove the AP if you no longer want to manage it with the UniFi software.



**Remove** Remove the Access Point from the location on the map.

**Show:** You can select to show labels or details and wireless coverage on the map. The following are the options available:

- **Labels** Displays the name of the Access Point.
- **Details** Displays the Access Point name, MAC address, transmit/receive channel, number of users connected, and number of guests connected.
- **Coverage** Displays a visual representation of the range covered by the Access Point.

**Map:** If multiple maps have been uploaded, you can select which map you want to view using this option.

**Configure Maps** Use this option to add maps or edit the current map(s).

**Zoom Slider** Use to zoom the map detail in and out.

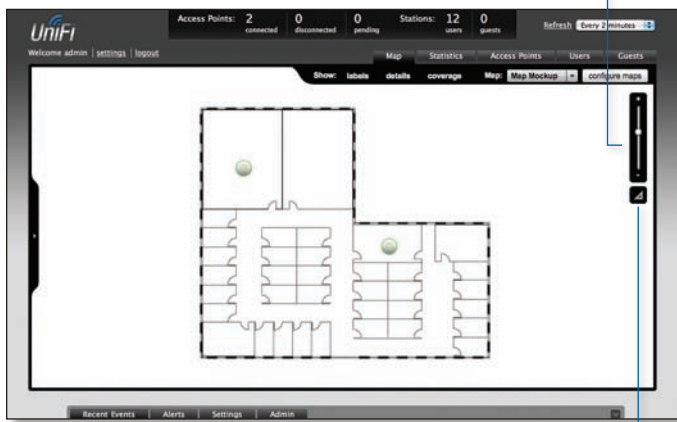

**Set Map Scale** Use this option to define the scale of the map. You will draw a line and define the distance that the line represents.

### Setting the Map Scale

1. Click the **Set Map Scale** button.
2. Click and hold to draw a line in the area that you want to use to set the scale of the map. If you need to redraw the line, just click and hold again to draw a new line. Once you're happy with the line, click **Next**.

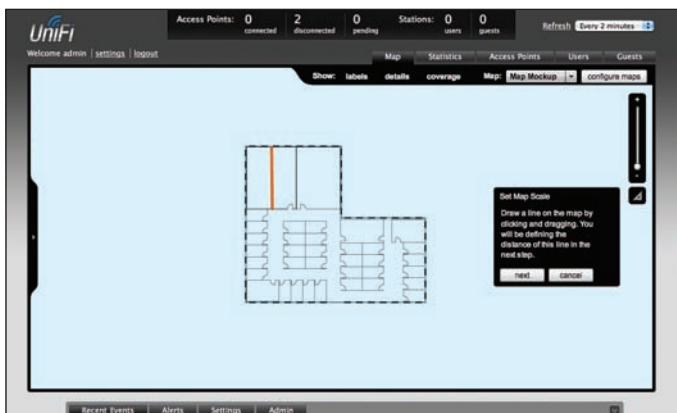

3. Enter the distance that the line represents in the *Distance:* field. The distance is specified in meters by default but you can switch to feet using the drop-down selection menu on the right. Click **Next**.

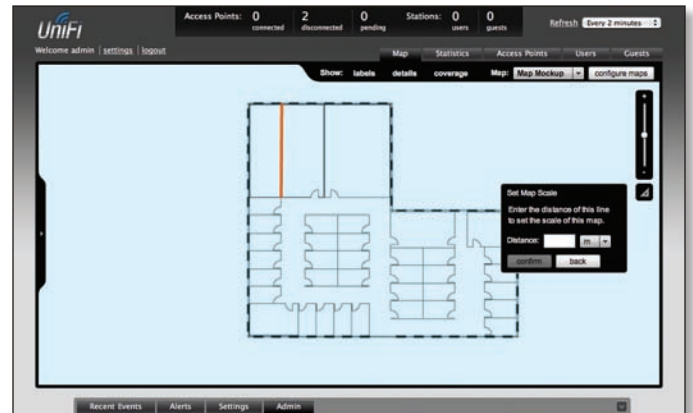

### Statistics

The *Statistics* tab provides a visual representation of the network traffic connected to your managed APs. Charts representing the number of clients and network traffic are displayed. An hour by hour chart of the usage over the last 24 hours is also displayed on this screen.



### Access Points

The *Access Points* tab displays a list of managed Access Points with their name, IP address, status, number of clients connected, download/upload statistics, and their transmit/receive channel.

Name/MAC Address	IP Address	Status	Num Clients	Download	Upload	Channel	Actions
office	192.168.1.173	Connected	5	181M	60.7M	11 (ng)	Restart Locate Upgrade
lab.AP	192.168.0.225	Connected	6	149M	47.4M	6 (ng)	Restart Locate Upgrade

**Search** Allows you to search the tables for any information that is displayed.

**Name/Mac Address** Displays the hostname, alias, or MAC address of the Access Point. You can click on the name to get additional details on the Access Point.

**IP Address** Displays the IP address of the Access Point.

**Status** Displays the connection status information.

**Num Clients** Displays the number of clients connected to the Access Point.

**Download** Displays the total size of downloads via the Access Point.

**Upload** Displays the total size of uploads via the Access Point.

**Channel** Displays the transmit/receive channel being used by the Access Point.

**Actions** Select an action button to perform the desired action:

- **Restart** Restart the selected Access Point.
- **Locate** Locate the Access Point on the map. The LED on unplaced APs will flash to indicate which AP it is so that you can place it in the correct location on the map.
- **Upgrade** When Automatic Upgrade is enabled, the Access Points will be automatically upgraded. The Upgrade option is used to manually update the firmware on the Access Point.

## Users

The *Users* tab displays a list of users that are connected to the primary wireless network of the Access Point.

Name/MAC Address	IP Address	Access Point	Signal	Down	Up	Activity	Uptime	Actions
jenry	192.168.1.207	jenry's office	99%	364M	64.3M	5h 43m 53s	[block] [reconnect]	
AD05ULY00185	192.168.1.119	jenry's office	67%	236M	25.8M	5h 31m 53s	[block] [reconnect]	
stomic	192.168.0.5	jenry's office	99%	111M	10.8M	5h 23m 21s	[block] [reconnect]	
tolene_PC	192.168.1.56	jenry's office	57%	57.7M	4.79M	4h 28m 3s	[block] [reconnect]	
TNYAMUCHENG0189	192.168.1.201	HR Lab	54%	29.7M	4.25M	5h 46m 38s	[block] [reconnect]	
ZILONG0081	192.168.1.101	HR Lab	50%	16.5M	12.2M	2h 2m 13s	[block] [reconnect]	
VM-MBP	192.168.0.101	jenry's office	72%	988K	1.18M	5h 37m	[block] [reconnect]	
ICA-iPhone	192.168.1.141	jenry's office	97%	430K	255K	4h 4m 21s	[block] [reconnect]	

**Name/MAC Address** Displays the hostname, alias, or MAC address of the connected user. You can click on the name to get additional details.

**IP Address** Displays the IP address assigned to the user.

**Access Point** Displays the hostname or alias of the Access Point. You can click on the name to get additional details on the Access Point.

**Signal** Displays the signal strength from the AP to the client.

**Up** Displays the total size of files uploaded from the user.

**Down** Displays the total size of files downloaded from the user.

**Activity** Displays the level of activity for each user.

Bars	Activity Level (Bytes per second)
	Idle
■	500
■■	8000
■■■	64000
■■■■	512000
■■■■■	2048000

**Uptime** Displays the total time the user has been connected for this session.

**Actions** Click an action button to perform the appropriate action.

- **Block** Click this to block a specific user from accessing the Access Point. This will add the client to the Blocked Device list.
- **Reconnect** Click this button to reconnect a specific user to the Access Point.

## Guests

The *Guests* tab displays a list of users that have connected to the guest network of the Access Point.

Name/MAC Address	Status	IP Address	Access Point	Signal	Down	Up	Activity	Uptime	Actions
00:16:c8:ba:ad:f8	Authorized	192.168.25.106	00:15:6d:5a:e3:a1	47%	35.0M	1.07M	5m 11s	[block] [disconnect]	
iPhone	Authorized	192.168.25.104	00:15:6d:5a:e3:a1	62%	54.0	4.04K	6s	[block] [disconnect]	

**Name/MAC Address** Displays the hostname, alias, or MAC address of the connected guest. You can click on the name to get additional details.

**Status** Indicates whether the guest is authorized or not. For authorization, guests must accept the *Terms of Use* if the guest portal is enabled and authenticate if authentication is enabled.

**IP Address** Displays the IP address assigned to the guest.

**Access Point** Displays the hostname or alias of the Access Point. You can click on the name to get additional details on the Access Point.

**Signal** Displays the signal strength from the AP to the client.

**Up** Displays the total size of files uploaded from the guest.

**Down** Displays the total size of files downloaded from the guest.

**Activity** Displays the level of activity for each guest.

Bars	Activity Level (Bytes per second)
	Idle
■	500
■ ■	8000
■ ■ ■	64000
■ ■ ■ ■	512000
■ ■ ■ ■ ■	2048000

**Uptime** Displays the total time the user has been connected for this session.

**Actions** Click an action button to perform the appropriate action.

- **Block** Click this to block a specific guest from accessing the Access Point.
- **Reconnect** Click this button to reconnect a specific guest to the Access Point.

## Recent Events

Displays a list of recent events including the date and time the event occurred and the details of the event. The user and AP names are clickable links.

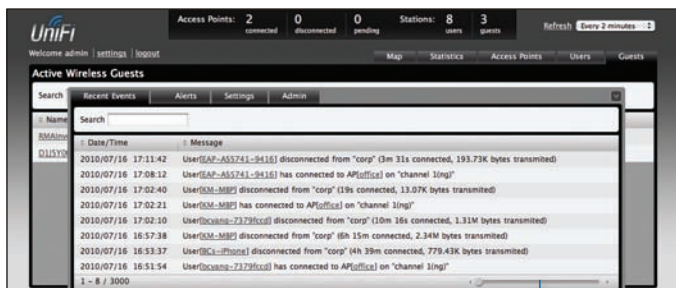

**Event Slider** Move the slider right and left to navigate between pages of events.

**Search** Allows you to enter text you want to search for. Simply begin typing, there is no need to press enter.

## Clicking on an Event Device Link

The event messages have clickable links [in brackets underlined in gray text] for access points and users/guests. Details vary based on the selection.

## AP

The upper part of the window has 4 clickable tabs. The bottom of the window has a **Locate** and **Restart** button. Use the **Locate** button to flash the LED on the Access Point and flash the Access Point icon on the map. Use the **Restart** button to restart the Access Point. The 4 tabs contain the following information:

### Details

Displays details on the Access Point. Click **Radio** to display the channel and transmit/receive statistics.

### Overview

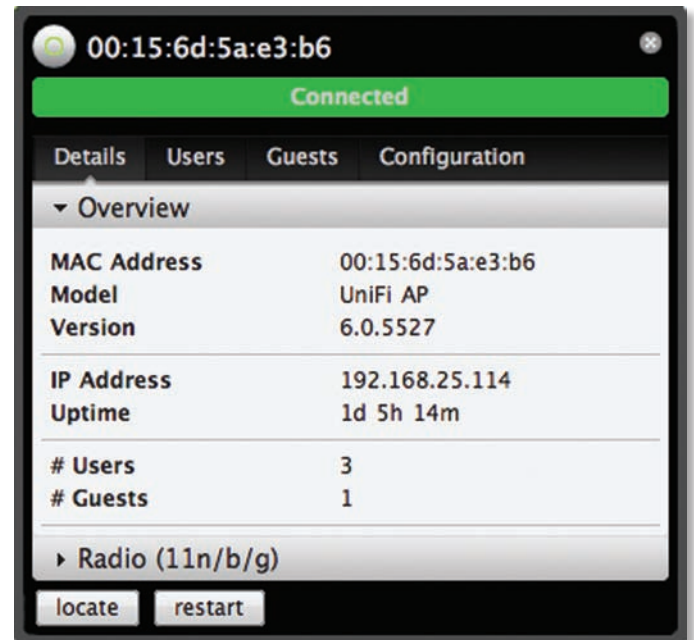

- **MAC address** Displays the MAC address of the Access Point.
- **Model** Displays the model information.
- **Version** Displays the version of software used on the Access Point.
- **IP address** Displays the IP address of the Access Point.
- **Uptime** Displays the amount of time the Access Point has been running without interruption.
- **# Users** Displays the number of users connected to the primary network.
- **# Guests** Displays the number of users connected to the guest network.

**Radio (11n/b/g)**

Click **Radio** to display the channel and transmit/receive statistics.

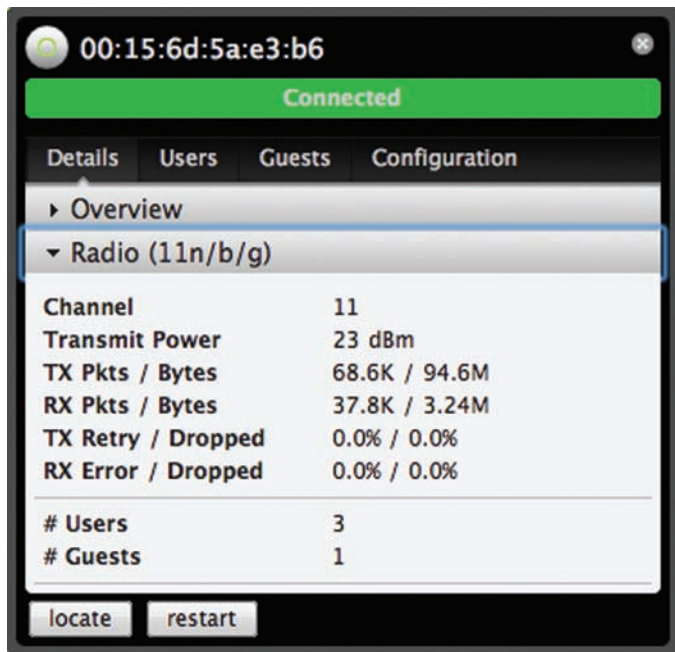

- **Channel** Displays the wireless channel being used.
- **Transmit Power** Displays the transmit power.
- **TX Pkts / Bytes** Displays the number of packets and total bytes transmitted by the Access Point.
- **RX Pkts / Bytes** Displays the number of packets and total bytes received by the Access Point.
- **TX Retry / Dropped** Displays the percentage of transmitted packets that needed to be resent and the percentage of packets that were dropped.
- **RX Error / Dropped** Displays the percentage of packets received that needed to be resent and the percentage of packets that were dropped.
- **# Users** Displays the number of users connected to the primary network.
- **# Guests** Displays the number of users connected to the guest network.

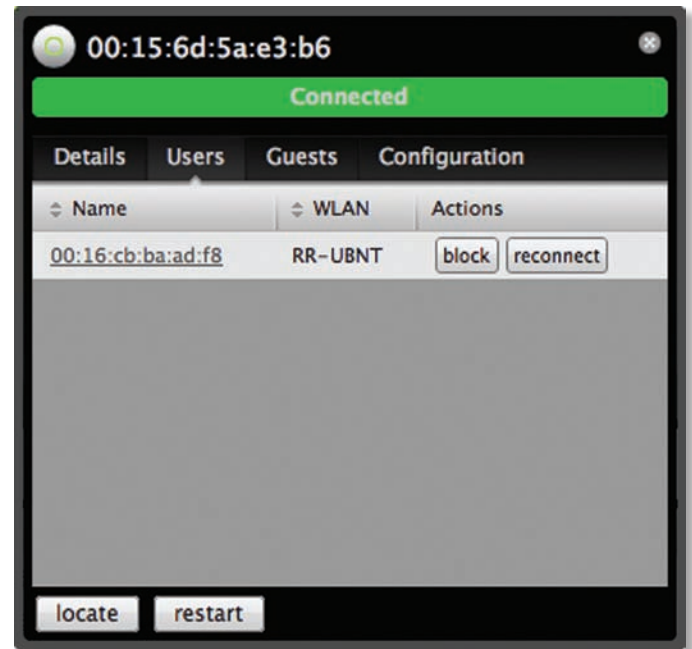
**Users**

**Name** Displays the name (MAC address if not defined) of users connected to the primary network of the selected Access Point. You can click on the name to display additional details of each user (see *User/Guest* on the following page) or click a button to perform the appropriate action.

**WLAN** Displays the SSID (network name) of the wireless network the user is connected to.

**Actions** Select from one of the following actions:

- **Block** Click this to block a specific user from accessing the Access Point. This will add the client to the Blocked Device list.
- **Reconnect** Click this button to reconnect a specific user to the Access Point.

## Guests

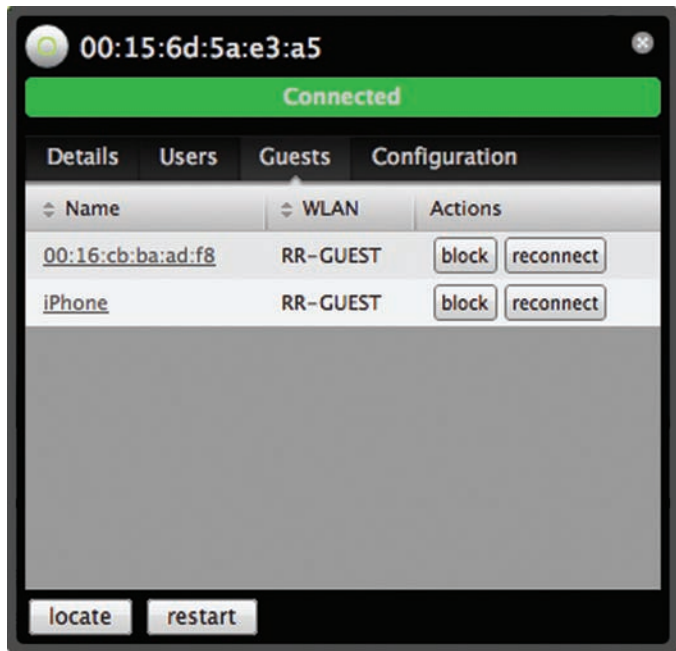

**Name** Displays the name (MAC address if not defined) of users connected to the guest network of the selected Access Point. You can click on the name to display additional details of each user (see *User* below) or click a button to perform the appropriate action.

**WLAN** Displays the SSID (network name) of the wireless network the guest is connected to.

**Actions** Select from one of the following actions:

- **Block** Click this to block a specific user from accessing the Access Point. This will add the client to the Blocked Device list.
- **Reconnect** Click this button to reconnect a specific user to the Access Point.

## Configuration

Allows you to change device configuration settings. Be sure to click the **Apply** button to apply any changes that you make.

### Config

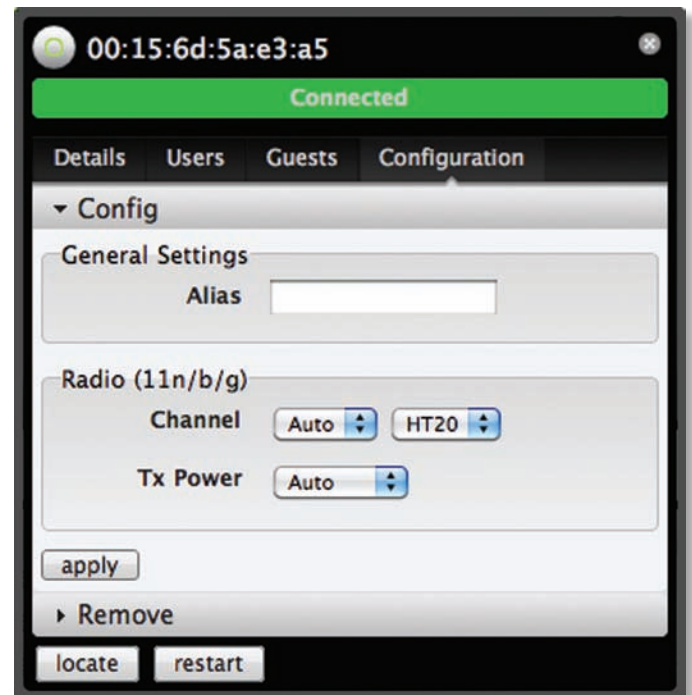

**Alias** Allows you to name the device.

**Channel** Select a channel or leave the default auto setting. You can also use the default HT20 for 20 MHz operation or HT40 for 40 MHz operation.

**Tx Power** By default the transmit power is set to Auto. You can also manually select High, Medium, or Low.

### Remove

**Remove** You can remove the AP if you no longer want to manage it with the UniFi software.

## User/Guest

The User and Guest hyperlinks bring up a window with 4 clickable tabs. The 4 tabs contain the following information:

### Overview

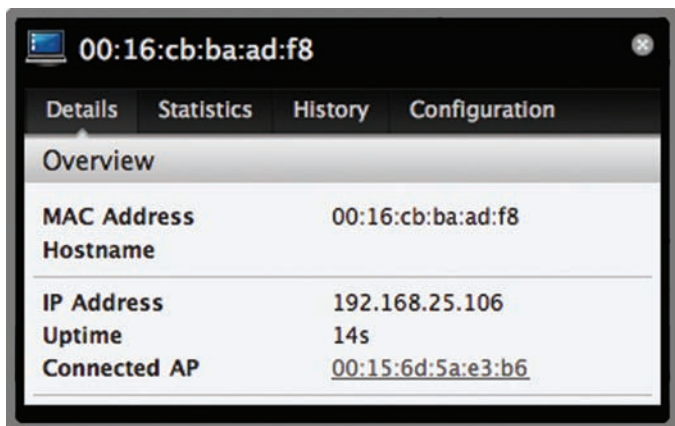

**MAC address** Displays the MAC address of the Access Point.

**Hostname** Displays the name (if defined).

**IP address** Displays the IP address of the Access Point.

**Uptime** Displays the amount of time the Access Point has been running without interruption.

**Connected AP** Displays the name or MAC address of the Access Point this user is connected to.

### Statistics

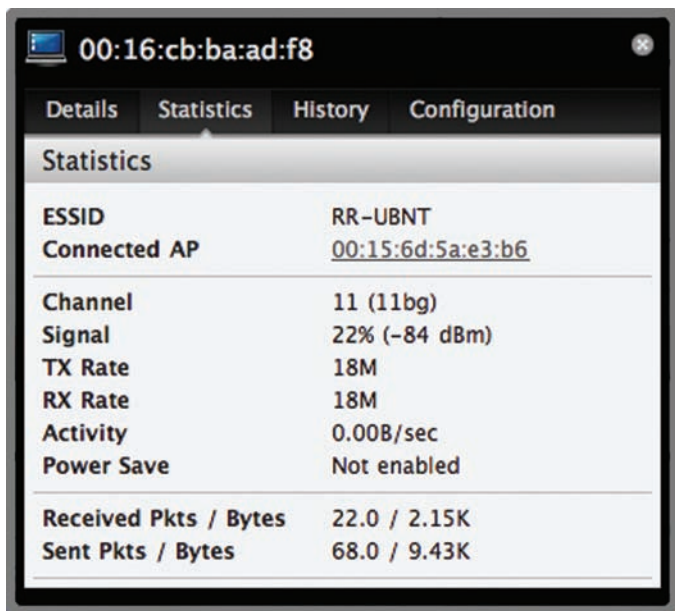

**ESSID** Displays the wireless network name (SSID) of the network that the user is connected to.

**Connected AP** Displays the MAC address or name of the Access Point the user is connected to.

**Channel** Displays the channel being used for wireless communication.

**Signal** Displays the signal level.

**TX Rate** Displays the transmit rate.

**RX Rate** Displays the reception rate.

**Activity** Displays user activity.

**Power Save** Indicates whether power saving is enabled.

**Received Pkts / Bytes** Displays the number of packets and total bytes transmitted by the user.

**Sent Pkts / Bytes** Displays the number of packets and total bytes received by the user.

### History

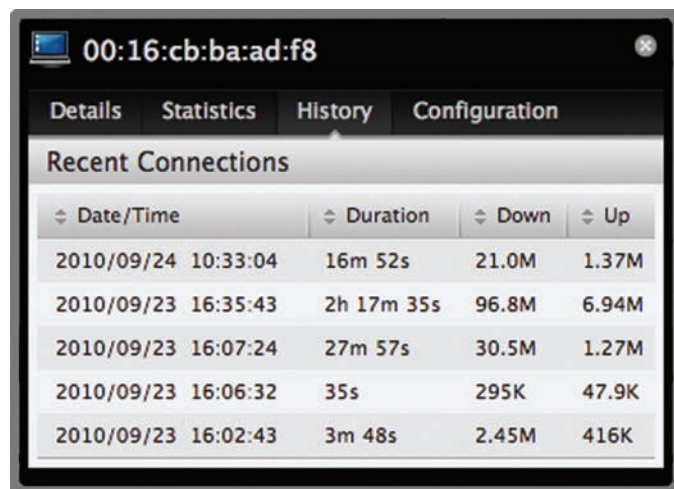

**Date/Time** Displays the date and the time the user connected to the Access Point.

**Duration** Displays the time duration that the user was connected to the Access Point.

**Down** Displays how many bytes were downloaded by the user during the session.

**Up** Displays how many bytes were uploaded by the user during the session.



## Configuration

### Config

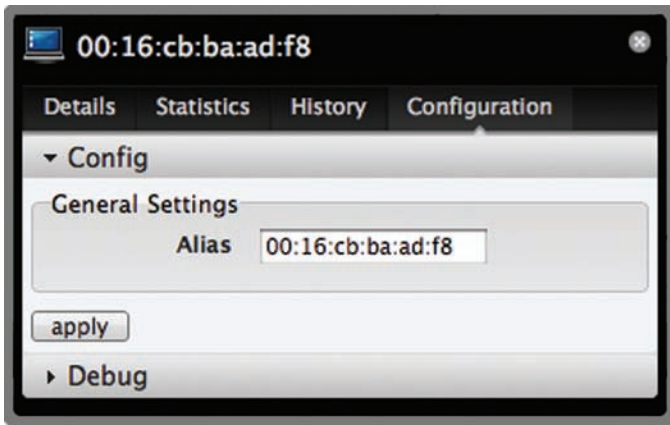

**Alias** Allows you to enter a name for the user. Be sure to click **Apply** to save your name change.

### Debug

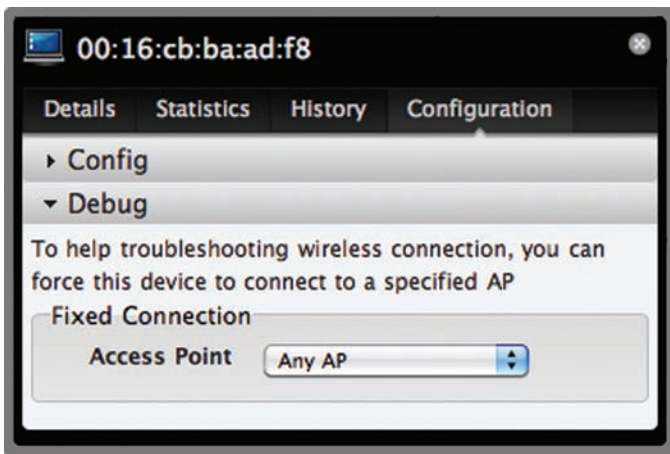

**Debug** Allows you to force a device to connect to a specific Access Point.

## Alerts

Important events are displayed in the alerts window. The date and time of the event and the message are displayed.

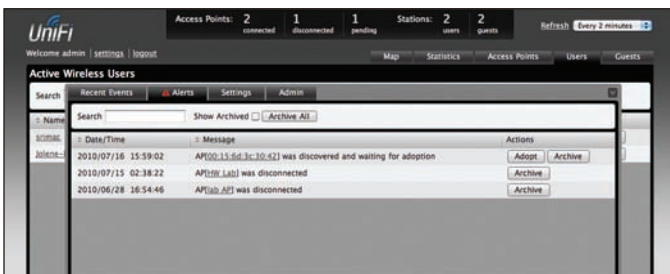

**Search** Allows you to enter text you want to search for. Simply begin typing, there is no need to press enter.

**Show Archived** Show all of the alert messages that have been archived.

**Archive All** Archive all of the alert messages displayed on the screen.

**Adopt** Click this button to adopt an access point that is waiting for adoption.

**Archive** Archive the selected alert message.

## Settings



**System** System related settings.



**Guest Control** Guest portal and policies.



**Wireless Networks** Wireless networks.



**Blocked Devices** List of blocked wireless devices.

### Settings >> System

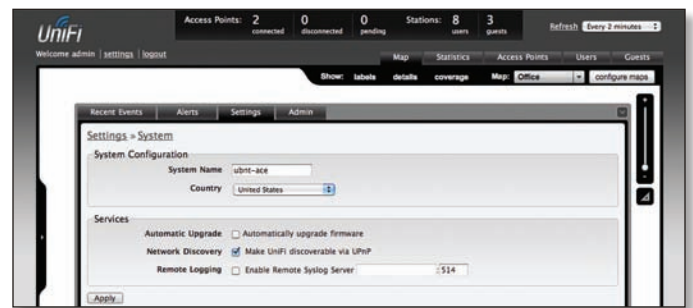

### System Configuration

**System Name** Editable field with the system name.

**Country** Select your country from the drop-down list.

### Services

**Automatic Upgrade** When enabled, this option will automatically upgrade your firmware when an update is available.

**Network Discovery** When enabled, this option allows UniFi to be discoverable via UPnP. This option is enabled by default.

**Remote Logging** Enable to define a remote syslog server. Enter the IP address and port of the syslog server.

Be sure to click **Apply** to save any changes that you have made.

## Settings >> Guest Control

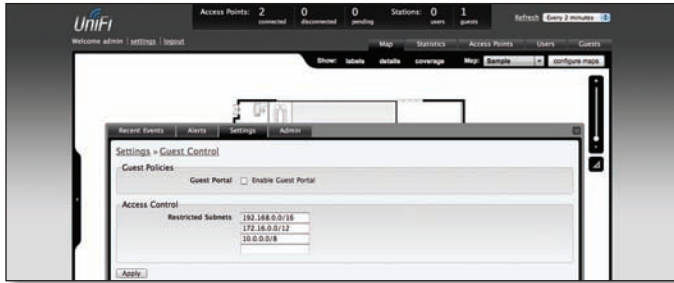

### Guest Policies

**Guest Portal** This option is disabled by default. When disabled, guests can access the Internet without entering a password or accepting terms of use. When this option is enabled, you can control the guest access portal.

You can select from the following authentication and landing page controls:

### Authentication

- **No authentication** When this option is selected, guests are not required to login but will be required to accept the Terms of Use before gaining access to the Internet.

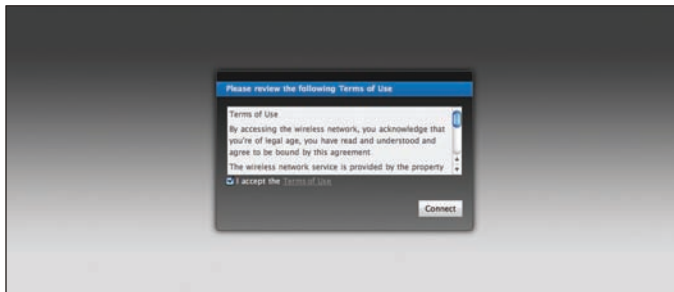

- **Simple Password** When this option is selected, guests are required to enter the simple password entered here and are required to accept the Terms of Use before gaining access to the Internet.
- **External Portal Server** Enter the IP address of your external server if you have a custom guest portal.

### Landing Page

- **Redirect to the original URL** When this option is selected, guests are directed to the URL they requested after accepting the terms of use.
- **Promotional URL** When this option is selected, guests are redirected to the URL that you specify here after accepting the terms of use. Be sure to specify the URL with http:// in front of the web address. Example: **http://www.ubnt.com**

### Access Control

**Restricted Subnets** Enter in any subnets that you don't want guests to be able to access.

## Settings >> Wireless Networks

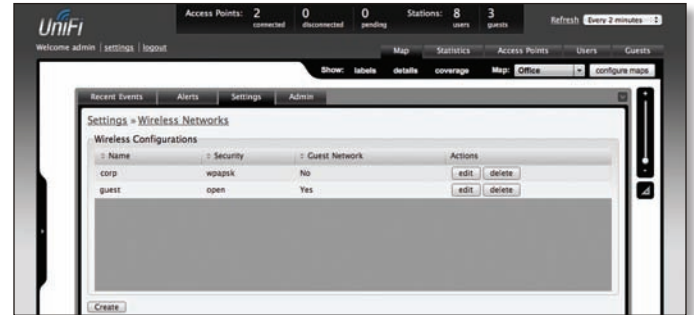

### Wireless Configurations

**Name** Displays the wireless network name (SSID).

**Security** Displays the type of security being used on your wireless network.

**Guest Network** Indicates whether the network is a guest network.

**Actions** Select an action button to perform the desired action:

**Edit** Select **Edit** to make changes to the wireless network settings.

**Delete** Select to delete the wireless network.

### Wireless Configuration

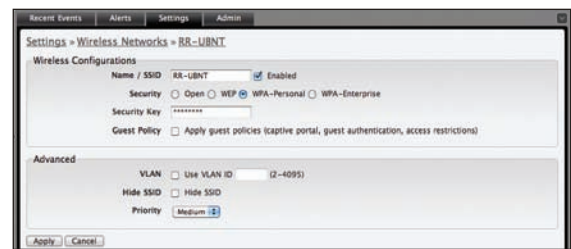

- **Name/SSID** Allows you to edit the wireless network name (SSID).
- **Security** Selects the type of security to use on your wireless network.
  - **Open** This option is typically only used on the Guest network. When enabled, wireless network access is open to anyone without needing a password.
  - **WEP** WEP (Wired Equivalent Privacy) is the oldest and least secure security algorithm. WPA security methods should be used when possible.
- **WEP Key** Enter a WEP encryption key in hexadecimal format. You can enter a 64-bit or 128-bit key:

Type	HEX
64-bit	10 Hexadecimal Characters (0-9, A-F or a-f) Example: <b>00112233AA</b>
128-bit	26 Hexadecimal Characters (0-9, A-F or a-f) Example: <b>00112233445566778899AABBCC</b>

- **Key Index** Specifies the Index of the WEP Key used. 4 different WEP keys can be configured at the same time, but only one is used. The effective key is set by choosing 1, 2, 3 or 4.
- **WPA-Personal** WPA™ or Wi-Fi Protected Access was developed as a stronger encryption method over WEP. WPA-Personal requires a passphrase to connect to the wireless network.
  - **Security Key** Enter the passphrase that users will use to connect to the wireless network.
- **WPA-Enterprise** WPA Enterprise uses a RADIUS server to authenticate users on the wireless network.
  - **IP Address** This is where the IP address of the RADIUS server is specified.
  - **Port** The port number is entered here. By default it is 1812.
  - **Password** The password used to authenticate on the RADIUS server is entered here.
- **Guest Policy** Select this option to enable guest access policies on this wireless network.

### Advanced

- **VLAN** To use a VLAN, select *Use VLAN ID* and enter the port number.
- **Hide SSID** Select this option if you don't want the SSID to be broadcast.
- **Priority** Defines the traffic priority, low, medium, or high.

Be sure to click **Apply** to save any changes that you have made. Click **Cancel** to discard changes.

### Settings >> Admin Settings



**Admin Name** Displays the current admin name used to login. To change the admin name, simply enter a new name and click **Apply**.

**Password** A new password can be entered in this field. Be sure to enter the password again in the *Confirm* field and then click **Apply** to save your new password.

**Confirm** Used to confirm your new password.

**Language** Selects the language for use in the interface.

## Admin

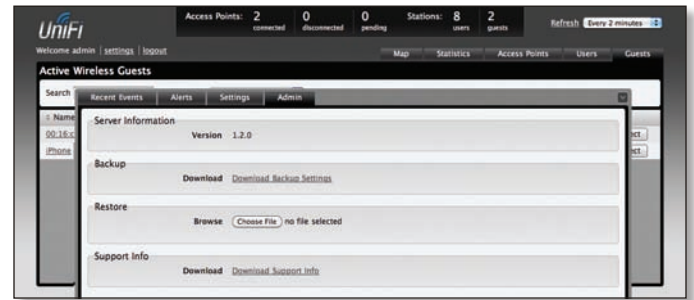

### Server Information

**Version** The software version is displayed here. If there is an update, UniFi will automatically download it and display it here.

### Backup

**Download Backup Settings** Click to download a file that contains all of your settings so you can restore them later if you choose.

### Restore

**Choose File** Select this option to restore settings from a backup file that you've already downloaded.

### Support Info

**Download Support Info** Select this option to download a file to your computer with information about your configuration that can be emailed to our support team.

## Appendix A: Specifications

Dimensions	20 x 20 x 3.65 cm
Weight	290 g (430 g with mounting kits)
Ports	Ethernet (Auto MDX, auto-sensing 10/100 Mbps)
Buttons	Reset
Antennas	2 Integrated (supports 2x2 MIMO with spatial diversity)
Wi-Fi Standards	802.11 b/g/n*
Power Method	Passive Power over Ethernet (12-24V)
Power Supply	24V 1A PoE Adapter included
Maximum Power Consumption	4W
Max TX Power	23 dBm
BSSID	Up to four per radio
Power Save	Supported
Wireless Security	WEP, WPA-PSK, WPA-TKIP, WPA2 AES, 802.11i
Certifications	CE, FCC, IC
Mounting	Wall/Ceiling (Kits included)
Operating Temperature	-10°C to 70°C (14°F to +158° F)
Operating Humidity	5% - 80% Condensing

### Advanced Traffic Management

VLAN	802.1Q
Advanced QoS	WLAN prioritization
Guest traffic isolation	Supported
WMM	Voice, video, best effort, and background
Concurrent Clients	100+

### Supported Data Rates (Mbps)

802.11n	MCS0 - MCS15 (6.5 Mbps to 300 Mbps), HT 20/40
802.11b	1, 2, 5.5, 11
802.11g	6, 9, 12, 18, 24, 36, 48, 54

\* 2.4GHz

## Appendix B: Compliance Information

---

### FCC

Changes or modifications not expressly approved by the party responsible for compliance could void the user's authority to operate the equipment.

NOTE: This equipment has been tested and found to comply with the limits for a Class A digital device, pursuant to part 15 of the FCC Rules. These limits are designed to provide reasonable protection against harmful interference when the equipment is operated in a commercial environment. This equipment generates, uses, and can radiate radio frequency energy and, if not installed and used in accordance with the instruction manual, may cause harmful interference to radio communications. Operations of this equipment in a residential area is likely to cause harmful interference in which case the user will be required to correct the interference at his own expense.

The antennas used for this transmitter must be installed to provide a separation distance of at least the following from all users:

20 cm

### Industry Canada

This Class A digital apparatus complies with Canadian ICES-003.

Cet appareil numérique de la classe A est conforme à la norme NMB-003 Canada.

Operation is subject to the following two conditions:

1. This device may not cause interference, and
2. This device must accept any interference, including interference that may cause undesired operation of the device.

To reduce potential radio interference to other users, the antenna type and its gain should be so chosen that the equivalent isotropically radiated power (e.i.r.p.) is not more than that permitted for successful communication.

# Appendix C: Warranty

## General Warranty

UBIQUITI NETWORKS, Inc (“UBIQUITI NETWORKS”) represents and warrants that the Products furnished hereunder shall be free from defects in material and workmanship for a period of one (1) year from the date of shipment by UBIQUITI NETWORKS under normal use and operation. UBIQUITI NETWORKS sole and exclusive obligation under the foregoing warranty shall be to repair or replace, at its option, any defective Product that fails during the warranty period. The expense of removal and reinstallation of any item is not included in this warranty.

The foregoing warranty is exclusive and in lieu of all other warranties, express or implied, including the implied warranties of merchantability and fitness for a particular purpose and any warranties arising from a course of dealing, usage or trade practice with respect to the products. Repair or replacement in the manner provided herein shall be the sole and exclusive remedy of Buyer for breach of warranty and shall constitute fulfillment of all liabilities of UBIQUITI NETWORKS with respect to the quality and performance of the Products. UBIQUITI NETWORKS reserves the right to inspect all defective Products (which must be returned by Buyer to UBIQUITI NETWORKS factory freight prepaid).

No Products will be accepted for replacement or repair without obtaining a Return Materials Authorization (RMA) number from UBIQUITI NETWORKS. Products returned without an RMA number will not be processed and will be returned to Buyer freight collect. UBIQUITI NETWORKS shall have no obligation to make repairs or replacement necessitated by catastrophe, fault, negligence, misuse, abuse, or accident by Buyer, Buyer’s customers or any other parties. The warranty period of any repaired or replaced. Product shall not extend beyond its original term.

## Warranty Conditions

The foregoing warranty shall apply only if:

- (I) The Product has not been subjected to misuse, neglect or unusual physical, electrical or electromagnetic stress, or some other type of accident.
- (II) No modification, alteration or addition has been made to the Product by persons other than UBIQUITI NETWORKS or UBIQUITI NETWORK’S authorized representatives or otherwise approved by UBIQUITI NETWORKS.
- (III) The Product has been properly installed and used at all times in accordance, and in all material respects, with the applicable Product documentation.

## Disclaimer

UBIQUITI NETWORKS does not warrant that the operation of the products is error-free or that operation will be uninterrupted. In no event shall UBIQUITI NETWORKS be responsible for damages or claims of any nature or description relating to system performance, including coverage, buyer’s selection of products for buyer’s application and/or failure of products to meet government or regulatory requirements.

## Appendix D: Contact Information

---

### Ubiquiti Networks Support

Ubiquiti Support Engineers are located in the U.S. and Europe and are dedicated to helping customers resolve software, hardware compatibility, or field issues as quickly as possible. We strive to respond to support inquiries within a 24 hour period.

Email: [support@ubnt.com](mailto:support@ubnt.com)

Phone: 408-942-1153 (9 a.m. - 5 p.m. PST)

Skype: Ubiquiti\_Support

### Online Resources

Wiki Page: [www.ubnt.com/wiki](http://www.ubnt.com/wiki)

Support Forum: [www.ubnt.com/forum](http://www.ubnt.com/forum)

Knowledge Base: [www.ubnt.com/kb](http://www.ubnt.com/kb)

Downloads: [www.ubnt.com/support/downloads](http://www.ubnt.com/support/downloads)



91 E. Tasman Drive  
San Jose, CA 95134  
[www.ubnt.com](http://www.ubnt.com)

© 2010 Ubiquiti Networks, Inc. All rights reserved.