

Ultra-wideband Location System



Modular Ubitag V2.0HH

User's Manual

Written By
Andy Ward

Ubisense Limited
St Andrew's House
St Andrew's Road
Chesterton
Cambridge
CB4 1DL
ENGLAND

Tel: +44 (0)1223 535 170
Fax: +44 (0)1223 535 167

Email: support@ubisense.net
WWW: <http://www.ubisense.net/>

Released: October 2009

Table of Contents

Introduction	1
Regulatory Information for the United States of America.....	1
Regulatory Information for Europe	2
Regulatory Information for Canada	2
Modular Ubitag V2.0HH Specifications	3
Integration information.....	4
Annex A – Additional information pertaining to use of UWB for hand-held systems	5
United States of America	5
Canada.....	5
EU	6

Introduction

The Modular Ubitag V2.0HH is a wireless module intended to be integrated into other devices for the real-time location of hand-held objects. It transmits ultra-wideband (UWB) pulses which are picked up by a network of basestations (Ubisensors), allowing the 3D position of the tag to be found. The use of UWB technology enables greater positioning accuracy than other wireless technologies, because it is much less susceptible to multipath interference effects. Applications of the system include healthcare, workplace productivity, security, retail management and manufacturing.

This document describes the features and specifications of the Modular Ubitag and important regulatory information concerning its use and integration into other devices.

Regulatory Information for the United States of America

The Modular Ubitag V2.0HH is approved under subpart F (Part 15.519) and Part 15.249 of the FCC rules as a Modular Transmitter.

The product into which the Modular Ubitag V2.0HH is incorporated must bear a label per the FCC requirements which shows the FCC ID assigned to the Modular Ubitag V2.0HH as follows.

Contains FCC ID: SEAMOD21HH

The following information must be conveyed in the information supplied to the End User of the product into which the Modular Ubitag V2.0HH is incorporated:

This device complies with Part 15 of the FCC Rules. Operation is subject to the following two conditions: (1) this device may not cause harmful interference, and (2) this device must accept any interference received, including interference that may cause undesired operation.

UWB devices operating under the provisions of this section must be hand held, i.e., they are relatively small devices that are primarily hand held while being operated and do not employ a fixed infrastructure.

The use of antennas mounted on outdoor structures, e.g., antennas mounted on the outside of a building or on a telephone pole, or any fixed outdoors infrastructure is prohibited. Antennas may be mounted only on the hand held UWB device.

The user's manual or instruction manual shall caution the user that changes or modifications to the equipment not expressly approved by the party responsible for the grant of equipment authorization issued by the FCC could void the user's authority to operate the equipment under the grant of equipment authorization, for example:

CAUTION: Any changes or modifications made to the Modular Ubitag V2.0HH which are not expressly approved by the Ubisense Limited could void the user's authority to operate the equipment.

Regulatory Information for Europe

Hereby, Ubisense declares that this Modular Ubitag V2.0HH is in compliance with the essential requirements and other relevant provisions of Directive 1999/5/EC. A copy of the Declaration of Conformity for this equipment may be obtained from:

Ubisense
St. Andrew's House
St. Andrews Road
Chesterton
Cambridge
CB4 1DL
United Kingdom

This UWB transmitter must not be installed at a fixed outdoor location or used in flying models, aircraft and other forms of aviation.

Integrators should note that when the module is integrated into other equipment the combined device must meet all essential requirements and other relevant provisions of European Directives for that combined equipment. See ETSI TR102070-1 and ETSI TR102070-2 for further details.

Regulatory Information for Canada

The Modular Ubitag V2.0HH is approved under Industry Canada documents RSS-GEN, RSS-210 and RSS-220 as a Modular Transmitter.

The product into which the Modular Ubitag V2.0HH is incorporated must bear a label per Industry Canada requirements which shows the Industry Canada ID assigned to the Modular Ubitag V2.0HH as follows.

Contains IC: 8673A-MOD21HH

The following information must be conveyed in the information supplied to the End User of the product into which the Modular Ubitag V2.0HH is incorporated:

Operation is subject to the following two conditions: (1) this device may not cause harmful interference, and (2) this device must accept any interference received, including interference that may cause undesired operation.

Modular Ubitag V2.0HH Specifications

UWB transmitter section

Operates under:	FCC Part 15.517 (U.S) and EN302500 (E.U.)
Centre frequency:	7.488 GHz
-10dB bandwidth:	1.014 GHz

Conventional 2.4GHz radio transceiver

Operates under:	FCC Part 15.249 (U.S) and EN300440 (E.U.)
Lowest channel frequency:	2402.5MHz
Highest channel frequency:	2480.5MHz

General specifications

Dimensions (WxHxD):	24.5mm x 24.5mm x 9mm
Weight:	6g
Power supply:	2.3V-5.25V DC supply
Operating temperature range:	-40°C to +85°C

Integration information

The dimensions of the module PCB are shown below:

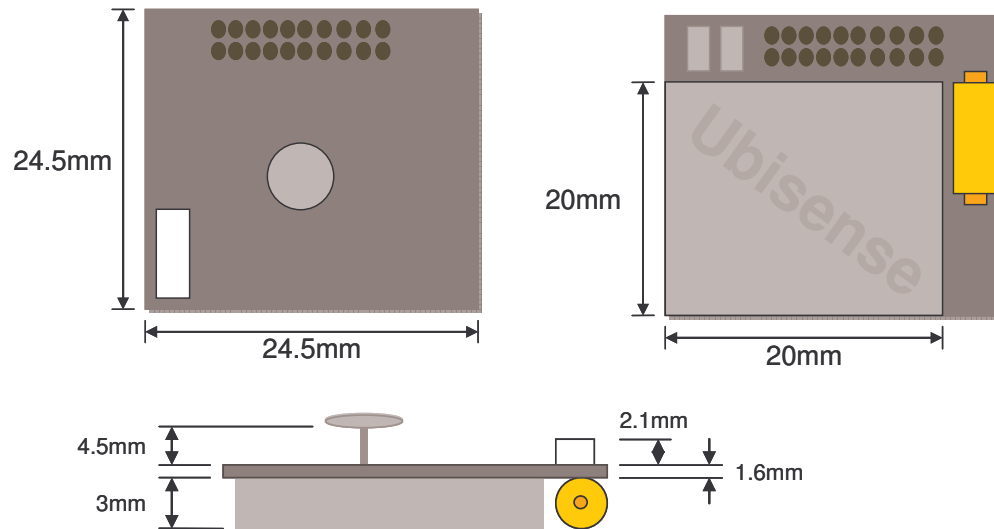

When mounting the tag on another device care must be taken to avoid occlusion of the antennas by tall components, shielding, or mounting screws. There should be an air gap of at least 1mm left around both of the antennas to avoid detuning.

While the connector provides some mechanical fixing it is not recommended that this is the only fixing point. A double-sided pad has been supplied that can be fitted to the top of the screening can to securely fix the module to a PCB.

When designing the PCB it is recommended that there is no ground plane underneath the module.

Power should be supplied on the following pins of the header:

2.3V-5.25V DC power input:	Pin 3
Ground:	Pins 5,6,9,10,14,18,19

A number of pins on the module's header may be used for digital input/output and analogue input. Note that application-specific use of these pins will require Ubisense to write modified firmware for the device, and therefore integrators wishing to make use of these features should contact Ubisense in the first instance.

The header used on the module is a **Major League TSHS-5 10-D-04-A-F-LF**, a standard 1.27mm pitch through-hole pin header. The recommended connector to use with the module is:

Connector: Major League LSSHS-5 10-D-06-F-TB-P-LF (SMD)

Please refer to <http://www.mlelectronics.com> for further information and ordering details.

Annex A – Additional information pertaining to use of UWB for hand-held systems

This section lists the regulatory requirements for hand-held UWB operation in various territories. Note that this text is presented only for informative purposes, and that all regulatory steps (labeling, instructions to the user, etc.) listed in the main section of this document must be fulfilled by integrators supplying the Ubitag Module V2.0HH to users.

United States of America

This section reiterates the technical requirements laid down in the FCC's rules which must be met by hand-held UWB devices operating under §15.519 of those rules. Modular Ubitags operating with a correctly-installed Ubisense location system will meet these requirements.

- UWB devices operating under the provisions of this section must be hand held, i.e., they are relatively small devices that are primarily hand held while being operated and do not employ a fixed infrastructure.
- A UWB device operating under the provisions of this section shall transmit only when it is sending information to an associated receiver. The UWB intentional radiator shall cease transmission within 10 seconds unless it receives an acknowledgement from the associated receiver that its transmission is being received. An acknowledgment of reception must continue to be received by the UWB intentional radiator at least every 10 seconds or the UWB device must cease transmitting.
- The use of antennas mounted on outdoor structures, e.g., antennas mounted on the outside of a building or on a telephone pole, or any fixed outdoors infrastructure is prohibited. Antennas may be mounted only on the hand held UWB device.
- UWB devices operating under the provisions of this section may operate indoors or outdoors.

Canada

This section reiterates the technical requirements laid down in Industry Canada's rules which must be met by UWB devices operating indoors under RSS-210. Modular Ubitags operating with a correctly-installed Ubisense location system will meet these requirements:

The device shall be designed so as to prevent its connection to antennas mounted on outdoor structures, e.g., antennas mounted on the outside of a building or on a telephone pole, or any fixed outdoors infrastructure.

The device is to transmit only when it is sending information to an associated receiver. The device shall cease transmission of information within 10 seconds unless it receives an acknowledgement from the associated receiver that its transmission is being received. An acknowledgment of reception must continue to be received by the UWB device at least every 10 seconds or the UWB device shall cease transmitting any information other than periodic signals used for the establishment or re-establishment of a communication link with an associated receiver.

EU

This section reiterates the technical requirements laid down in EN302500 which must be met by UWB devices:

- (1) The UWB transmitter equipment conforming to the present document shall not be:
 - installed at a fixed outdoor location;
 - installed or used in flying models, aircraft and other forms of aviation;
 - installed or used in a road or rail vehicle.

- (2) To minimize interference to other users of the radio spectrum, in particular outdoor radio stations, the equipment shall transmit only when it is sending information to a receiver or attempting to acquire or maintain association. The device shall cease transmission within ten seconds unless it receives an acknowledgement that its transmission is being received. An acknowledgement of transmission shall continue to be received by the UWB device at least every ten seconds, or it shall cease transmitting. Equipment covered by the present document shall include a receiver mechanism capable of receiving the reception acknowledgement from an associated receiver.

NOTE: As an example, the receiver mechanism might be capable of operating at frequency bands given in CEPT/ERC/REC 70-03, annex 1 and tested according to EN 300 220 or EN 300 440.

If a device ceases UWB transmissions due to lack of a reception acknowledgement, it shall wait for at least twelve seconds before reattempting to send information to a receiver or to acquire or maintain association with a receiver, unless it first receives an indication from an external source that its UWB transmissions are likely to be detected. In this latter case, the device may reattempt to send information to a receiver or to acquire or maintain association with a receiver immediately.