

Wideband Location System



Modular Ubitag V2.3

User's Manual

Written By
Andy Ward

Ubisense Limited
St Andrew's House
St Andrew's Road
Chesterton
Cambridge
CB4 1DL
ENGLAND

Tel: +44 (0)1223 535 170
Fax: +44 (0)1223 535 167

Email: support@ubisense.net
WWW: <http://www.ubisense.net/>

Released: October 2009

Table of Contents

Introduction	1
Regulatory Information for the United States of America.....	1
Modular Ubitag V2.3 Specifications.....	2
Integration information.....	3

Introduction

The Modular Ubitag V2.3 is a wireless module intended to be integrated into other devices for the real-time location of objects. It transmits wideband pulses which are picked up by a network of basestations (Ubisensors), allowing the 3D position of the tag to be found. The use of wideband technology enables greater positioning accuracy within buildings than other wireless technologies, because it is much less susceptible to multipath interference effects. Applications of the system include healthcare, workplace productivity, security, retail management and manufacturing.

This document describes the features and specifications of the Modular Ubitag and important regulatory information concerning its use and integration into other devices.

Regulatory Information for the United States of America

The Modular Ubitag V2.3 is approved Parts 15.249 and 15.250 of the FCC rules as a Modular Transmitter.

The product into which the Modular Ubitag V2.3 is incorporated must bear a label per the FCC requirements which shows the FCC ID assigned to the Modular Ubitag V2.3 as follows.

Contains FCC ID: SEAMOD23

The following information must be conveyed in the information supplied to the End User of the product into which the Modular Ubitag V2.3 is incorporated:

This device complies with Part 15 of the FCC Rules. Operation is subject to the following two conditions: (1) this device may not cause harmful interference, and (2) this device must accept any interference received, including interference that may cause undesired operation.

The user's manual or instruction manual shall caution the user that changes or modifications to the equipment not expressly approved by the party responsible for the grant of equipment authorization issued by the FCC could void the user's authority to operate the equipment under the grant of equipment authorization, for example:

CAUTION: Any changes or modifications made to the Modular Ubitag V2.3 which are not expressly approved by the Ubisense Limited could void the user's authority to operate the equipment.

Modular Ubitag V2.3 Specifications

Wideband transmitter section

Operates under:	FCC Part 15.250
Centre frequency:	6.545GHz
-10dB bandwidth:	0.963GHz

Conventional 2.4GHz radio transceiver

Operates under:	FCC Part 15.249
Lowest channel frequency:	2402.5MHz
Highest channel frequency:	2480.5MHz

General specifications

Dimensions (WxHxD):	24.5mm x 24.5mm x 9mm
Weight:	6g
Power supply:	2.3V-5.25V DC supply
Operating temperature range:	-40°C to +85°C

Integration information

The dimensions of the module PCB are shown below:

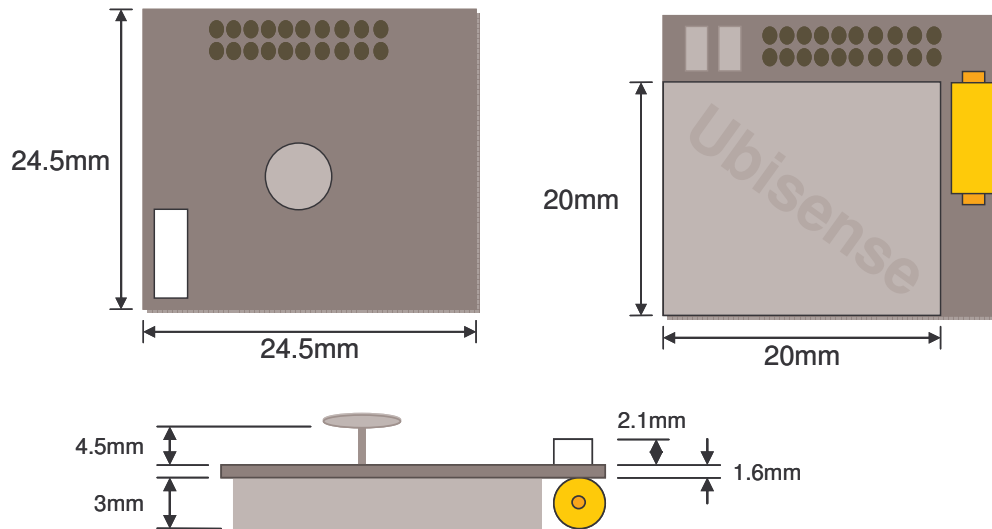

When mounting the tag on another device care must be taken to avoid occlusion of the antennas by tall components, shielding, or mounting screws. There should be an air gap of at least 1mm left around both of the antennas to avoid detuning.

While the connector provides some mechanical fixing it is not recommended that this is the only fixing point. A double-sided pad has been supplied that can be fitted to the top of the screening can to securely fix the module to a PCB.

When designing the PCB it is recommended that there is no ground plane underneath the module.

Power should be supplied on the following pins of the header:

2.3V-5.25V DC power input:	Pin 3
Ground:	Pins 5,6,9,10,14,18,19

A number of pins on the module's header may be used for digital input/output and analogue input. Note that application-specific use of these pins will require Ubisense to write modified firmware for the device, and therefore integrators wishing to make use of these features should contact Ubisense in the first instance.

The header used on the module is a **Major League TSHS-5 10-D-04-A-F-LF**, a standard 1.27mm pitch through-hole pin header. The recommended connector to use with the module is:

Connector: Major League LSSHS-5 10-D-06-F-TB-P-LF (SMD)

Please refer to <http://www.mlelectronics.com> for further information and ordering details.