

Ultra-wideband Location System

Ubitag V2.2

User's Manual

Written By

Andy Ward, Paul Webster

Ubisense Limited

St Andrew's House,

St Andrew's Road, Chesterton, Cambridge, CB4 1DL, ENGLAND

Tel: +44 (0)1223 535170

Fax: +44 (0)1223 535167

Email: support@ubisense.net

WWW: <http://www.ubisense.net/>

Revised: February 2007

Table of Contents

Introduction	1
Information to the User	1
Features of the Ubitag	2
Installation and Operation Instructions	3
Switching the Ubitag on for the first time.....	3
Fitting or replacing the batteries in the Ubitag.....	3
Troubleshooting.....	4
Ubitag Specifications	5
Requirements for device operation.....	5

Introduction

The Ubitag V2.2 is a wireless device intended to be used for the real-time location of objects within buildings. It transmits ultra-wideband pulses which are picked up by a network of basestations (Ubisensors) placed inside the building, allowing the 3D position of the tag to be found. The use of ultra-wideband technology enables greater positioning accuracy within buildings than other wireless technologies, because it is much less susceptible to multipath interference effects. Applications of the system include healthcare, workplace productivity, security, retail management and manufacturing.

This document describes the features and specifications of the Ubitag, important regulatory information concerning its use, and details on how to diagnose potential problems.

Information to the User

The Ubitag V2.2 is an ultra-wideband (UWB) wireless device certified under FCC Part 15.517. Its use is subject to technical requirements for indoor UWB systems, in particular the stipulation that the devices must only be used indoors. Users should note carefully the following information:

- **CAUTION:** This equipment may only be operated indoors. Operation outdoors is in violation of 47 U.S.C. 301 and could subject the operator to serious penalties.
- Ubitags will only operate (i.e. transmit UWB signals) in conjunction with an in-building Ubisensor network, which should be professionally installed. The installed Ubisensor network will be configured to cover only the area inside the building, preventing Ubitags from emitting UWB signals outdoors. Contact your system administrator if you are unsure as to the extent of the coverage of the Ubisense In-Building Location System in your building.
- This device complies with Part 15 of the FCC Rules. Operation is subject to the following two conditions: (1) this device may not cause harmful interference, and (2) this device must accept any interference received, including interference that may cause undesired operation.

Users should also carefully note the following information:

- **CAUTION:** Any changes or modifications made to the Ubitag which are not expressly approved by the Ubisense Limited could void the user's authority to operate the equipment.
- **NOTE:** This equipment has been tested and found to comply with the limits for a Class B digital device, pursuant to Part 15 of the FCC Rules. These limits are designed to provide reasonable protection against harmful interference in a residential installation. This equipment generates, uses and can radiate radio frequency energy and, if not installed and used in accordance with the instructions, may cause harmful interference to radio communications. However, there is no guarantee that interference will not occur in a particular installation. If this equipment does cause harmful interference to radio or television reception, which can be determined by turning the equipment off and on, the user is encouraged to try to correct the interference by one or more of the following measures:
 - Reorient or relocate the receiving antenna.
 - Increase the separation between the equipment and receiver.
 - Connect the equipment into an outlet on a circuit different from that to which the receiver is connected.
 - Consult the dealer or an experienced radio/TV technician for help.

Features of the Ubitag

The diagram below shows several important features of the Ubitag:

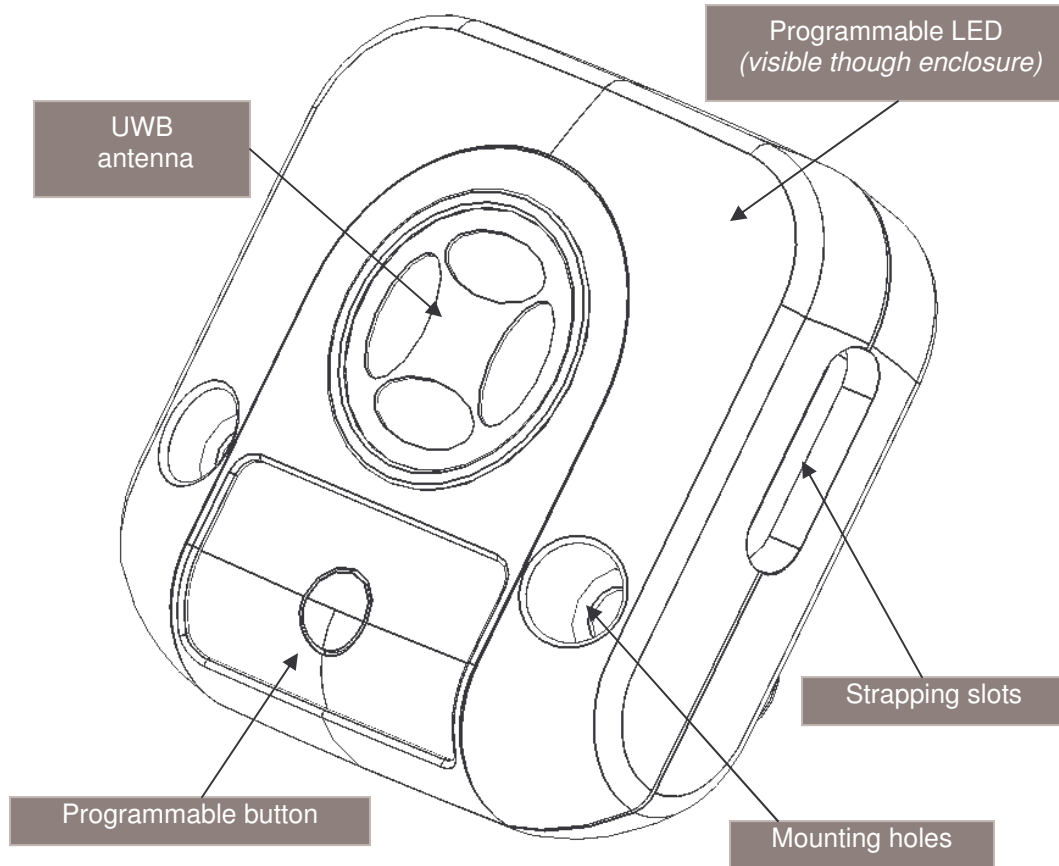

Installation and Operation Instructions

Switching the Ubitag on for the first time

The Ubitag is supplied with a battery, which needs to be fitted prior to operating the tag.

Fitting or replacing the batteries in the Ubitag

The Ubitag uses a Panasonic CR2477 3V lithium coin cell (or equivalent). Ubitags frequently report their battery health to the system via the Ubisensors, so system administrators should be notified by the system when the battery in a particular tag requires replacement.

To replace the battery in a Ubitag:

1. Unscrew the four screws in the back of the enclosure
2. Remove the rear of the enclosure to allow access to the battery
3. Slide out the old battery and dispose of carefully
4. Replace the battery with a new one, being careful to observe correct polarity

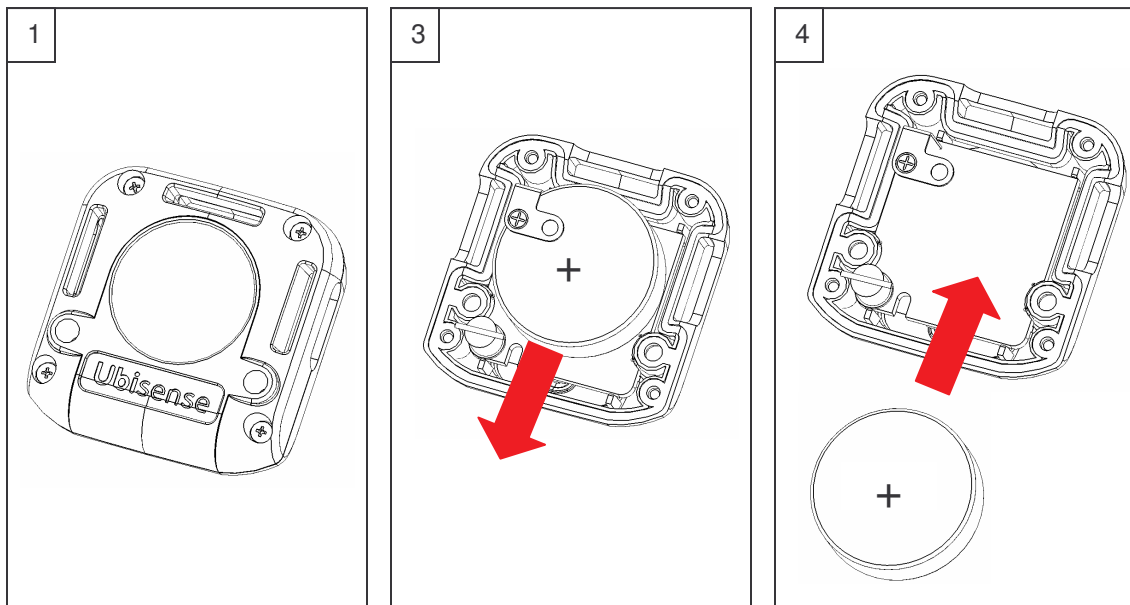

When the battery has been replaced, the Ubitag will flash its LED to indicate correct start-up, and the Ubisense Location System will then be able to determine the Ubitags' location.

Replace the PCB back into the front of the enclosure, replace the rear enclosure half and then tighten the four screws removed previously to complete reassembly of the device.

Should the Ubitag not flash its' LED to indicate correct start-up after the battery has been replaced, remove the battery, check that it is fresh, wait for 30 seconds, and reinsert the battery. Contact your system administrator if you continue to have problems replacing the battery in the Ubitag.

Troubleshooting

The activity of the LEDs on the Ubitag may be used to diagnose potential problems with the device:

- Periodic, short (less than 1/10th second) flashes of the LED indicate that the tag is in communication with the local Ubisensor network, and that the device is emitting UWB signals enabling its position to be found.
- Longer (half-second) flashes of the LED indicate that the tag is searching for signals from the local Ubisensor network, and that tracking functionality is not available at that location. Ensure that the tag is within an area covered by the Ubisense Location System.

If you are still unsure as to whether or not the Ubitag is operating correctly, contact your system administrator, who should be able to use Ubisense's monitoring tools to determine the extent and cause of any potential problem.

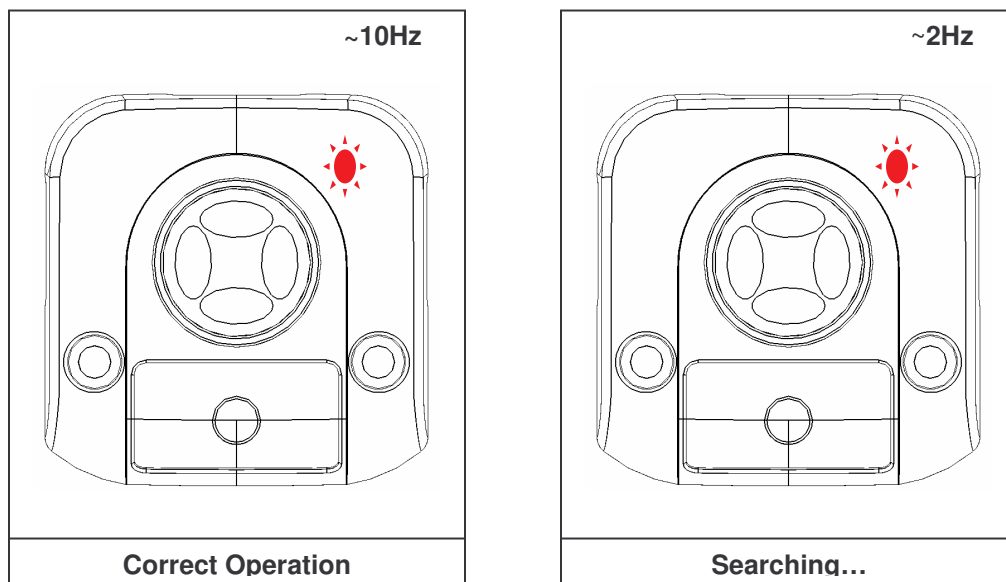

Ubitag Specifications

UWB transmitter section

Operates under:	FCC Part 15.517
Centre frequency:	6.954 GHz
-10dB bandwidth:	1.433 GHz

Conventional radio transceiver

Operates under:	FCC Part 15.249
Lowest channel frequency:	2402.5MHz
Highest channel frequency:	2480.5MHz

General specifications

Dimensions (WxHxD):	39mm x 38mm x 16mm
Power supply:	1 x Panasonic CR2477 3V lithium cell (or equivalent)
Operating temperature range:	-20°C to +60°C

Requirements for device operation

This section lists the technical requirements laid down in the FCC's rules which must be met by UWB devices operating indoors under §15.517 of those rules. Ubitags operating with a correctly-installed Ubisense location system will meet these requirements.

- (1) Indoor UWB devices, by the nature of their design, must be capable of operation only indoors. The necessity to operate with a fixed indoor infrastructure, e.g., a transmitter that must be connected to AC power lines, may be considered sufficient to demonstrate this.
- (2) The emissions from equipment operated under this section shall not be intentionally directed outside of the building in which the equipment is located, such as through a window or a doorway, to perform an outside function, such as the detection of persons about to enter a building.
- (3) The use of outdoor mounted antennas, e.g., antennas mounted on the outside of a building or on a telephone pole, or any other outdoors infrastructure is prohibited.
- (4) Field disturbance sensors installed inside of metal or underground storage tanks are considered to operate indoors provided the emissions are directed towards the ground.
- (5) A communications system shall transmit only when the intentional radiator is sending information to an associated receiver.